

# DESIGN OF THE MAIN RING BEAM POSITION MONITORS FOR FCC-ee

*E. Howling, CERN, John Adams Institute & University of Oxford*  
*Supervisors: P. N. Burrows, John Adams Institute & University of Oxford*  
*M. Gasior, CERN*

*With thanks to N. Chambers, R. Kieffer, T. Lefevre, B. Moser, A. Novokhatski, B. Spear, H. Sullivan, C. Zannini, CERN*

# Table of contents

- **Introduction**
  - FCC-ee BPM requirements
  - Response to different FCC-ee modes
- **Geometrical studies**
  - Varying parameters of a simplified button
  - Different geometries of a circular button
  - Non-standard geometries
- **Thermal studies**
- **Bench-marking**
- **Conclusions**

# Table of contents

- **Introduction**
  - FCC-ee BPM requirements
  - Response to different FCC-ee modes
- **Geometrical studies**
  - Varying parameters of a simplified button
  - Different geometries of a circular button
  - Non-standard geometries
- **Thermal studies**
- **Bench-marking**
- **Conclusions**

Find 5 festive John Adamses!



(not including this one)

# Introduction: FCC-ee BPM requirements

- Electrostatic button BPMs (see Fig.1), one rigidly fixed to each quadrupole.
- Shall provide orbit, turn-by-turn and bunch-by-bunch measurements .
- **High resolution** requirements (see Table. 1).
- **Low beam impedance** to prevent excessive heating of the button electrodes and to ensure beam stability.
- Need to be **reliable** and have rad tolerant electronics.
- $\sim 10'000$  needed across accelerator complex  $\rightarrow$  must have suitable cost for mass production.

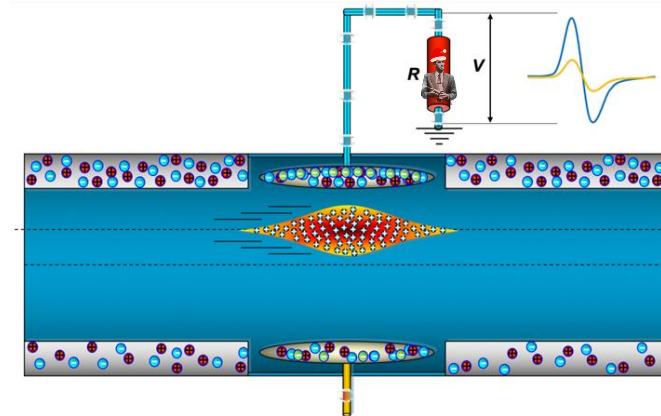

Fig 1: Diagram showing the principles of an electrostatic button BPM. [1].

Parameter	Requirement
orbit resolution	0.1 $\mu\text{m}$
turn by turn resolution	1 $\mu\text{m}$
accuracy	20 $\mu\text{m}$
minimum bunch spacing	25 ns

Table 1: Requirements for FCC-ee arc BPMs [2].

# Introduction: Response to different FCC-ee modes

- FCC-ee will run at several different beam modes, summarised in Table 2.
- The BPM must have **sufficient resolution** at the **lowest beam intensity** mode and **acceptable impedance** at the **highest beam intensity** mode.
- The lower intensity beam (~10% of nominal) during initial injection/commissioning and the variation of bunch charge during top-up injection (+/- 5%) must also be considered.

Mode	Z	W	ZH	$t\bar{t}$
Energy, GeV	45.6	80	120	182.5
Bunch intensity, $10^{11}$	2.14	1.45	1.15	1.55
Bunch charge, nC	34.3	23.2	18.4	24.8
RMS bunch length with SR/BS, mm	5.6/15.5	3.5/5.4	3.4/4.7	1.8/2.2
Number of bunches/beam	11200	1780	440	60
Bunch spacing, ns		25		
Beam current, mA	1270	137	26.7	4.9

Table 2: Beam parameters of the different running modes of the FCC-ee collider from the CDR [3].

# Introduction: Response to different FCC-ee modes

- I simulated a simplified BPM in CST at different FCC-ee modes, voltage results shown in Figs 2-4.
- There was up to a factor 30 difference between the raw peak to peak voltage of the lowest and highest intensity beams.

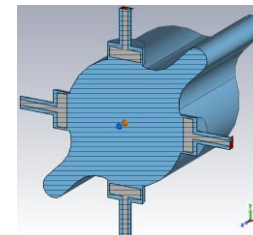

Fig 2: A simplified BPM model in CST, with FCC-ee beampipe.

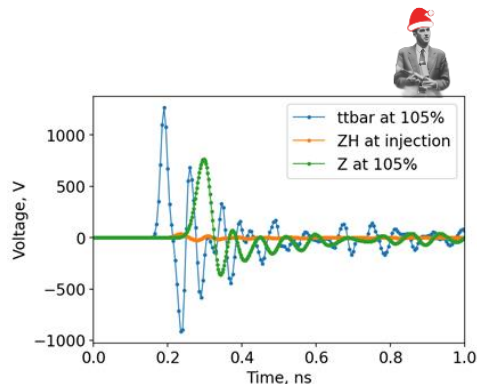

Fig 3: The voltage signal from a simplified pickup for the most extreme FCC-ee beams.

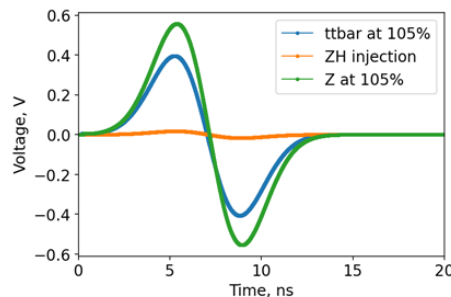

Fig 4: The voltage signal from a simplified pickup for the most extreme FCC-ee beams, with a 75 MHz filter applied.

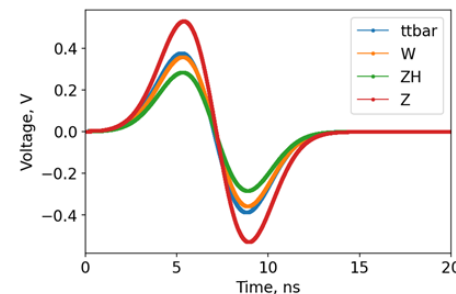

Fig 5: The Voltage signal from a simplified pickup for the SR FCC-ee beam modes, with a 75 MHz filter applied.



# GEOMETRICAL STUDIES



# Geometrical Studies: Varying Parameters of a Simplified Button

The effect of 4 parameters on 4 different properties was studied.

- **Peak-to-peak voltage:** increases significantly with the electrode radius, increases slightly with gap size, and decreases slightly with back gap size, whilst height has a negligible effect.
- **Wake-loss factor:** increases with both pickup radius and gap size, whilst gap and height have negligible effect.

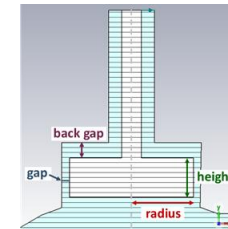

Fig 6: Simplified flat pickup with geometric parameters labelled.

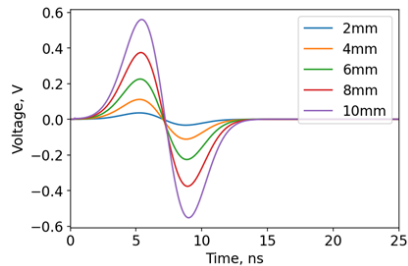

Fig 7: Voltage signal for different pickup radii, ttbar (SR) mode, with a 75 MHz filter applied.

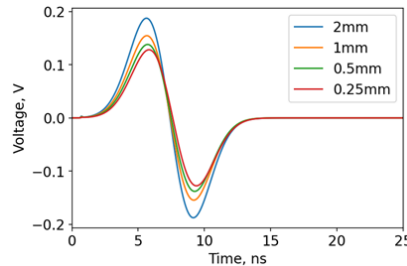

Fig 8: Voltage signal for different pickup gaps, Z (BS) mode, with a 75 MHz filter applied.

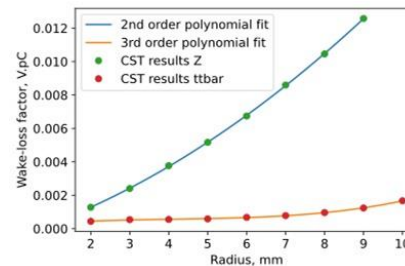

Fig 9: Wake-loss factor vs pickup radius.

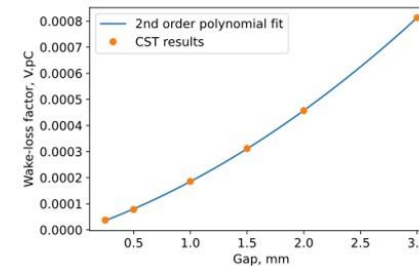

Fig 10: Wake-loss factor vs pickup gap, Z (BS) mode.

# Geometrical Studies: Varying Parameters of a Simplified Button

- **Resonant peak amplitudes** in the wake impedance spectrum: increase with radius and gap. Increasing the back gap slightly decreases the amplitude of the largest peak.
- **Resonant peak frequencies** in the wake impedance spectrum: increase as radius decreases, and increase slightly in frequency as height decreases and back gap decreases. Gap size has negligible impact.

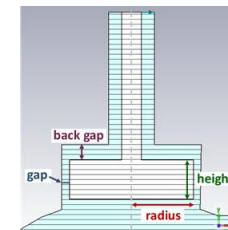

Fig 5: Simplified flat pickup with geometric parameters labelled.

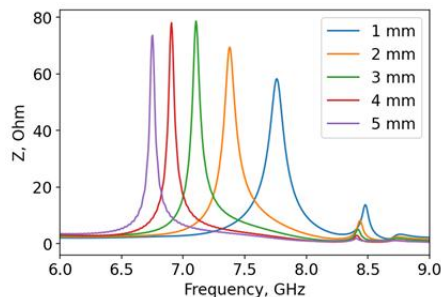

Fig 11: The largest peaks in wake impedance as a function of frequency for different **pickup heights**, ttbody (SR) mode.

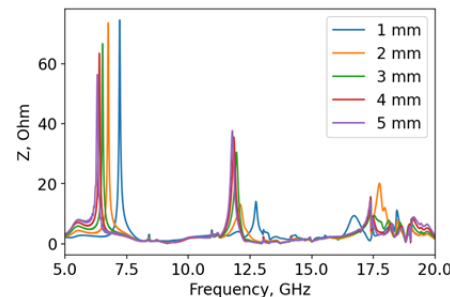

Fig 12: Wake impedance as a function of frequency for different **pickup back gaps**, ttbody (SR) mode.

# Geometrical Studies: Different Geometries of a Circular Button

- Conical pickups pushed the resonant peaks in the impedance spectrum to higher frequencies compared to a flat pickup, which is beneficial due to the beam spectrum having a lower amplitude at higher frequencies.
- Stepped buttons had no advantage.

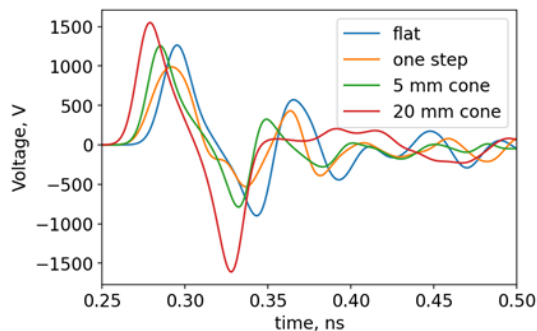

Fig 13: The initial voltage signal for different pickup geometries, simulated in CST with the ttbar (SR) mode.

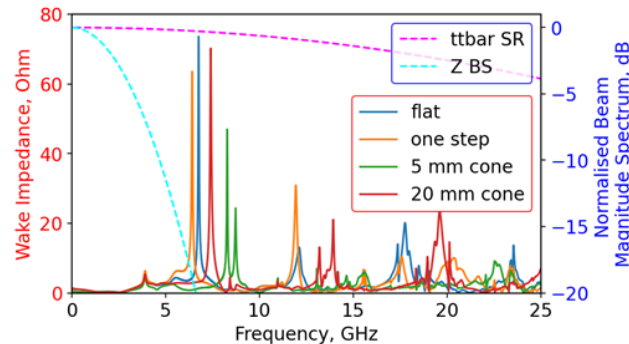

Fig 14: Wake impedance of conical and stepped buttons (solid lines) simulated in CST, along with the beam spectral content for two operational modes (dashed lines).

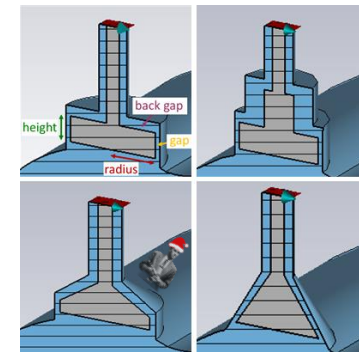

Fig 15: Cross-sections of some of the geometric models used. From top left clockwise: flat, stepped, conical and trapezoid.

# Geometrical Studies: Different Geometries of a Circular Button

- **Trapezoid pickups** had a similar effect to conical pickups, whilst being easier to manufacture.
- CST results comparing a 1 mm tall flat button and a trapezoid button with a 1 mm parallel section and 1 mm cone are shown in Figs. 14-15.
- The trapezoid has a **beneficial effect on the impedance** and a **similar voltage signal** to the flat button.

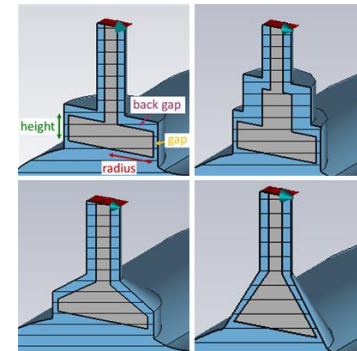

Fig 15: Cross-sections of some of the geometric models used. From top left clockwise: flat, stepped, conical and trapezoid.

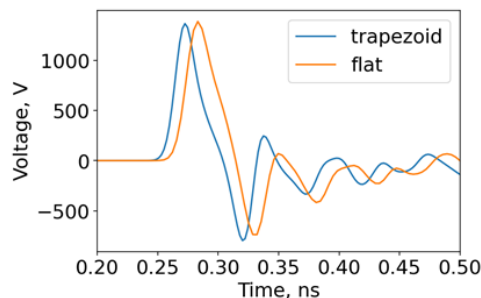

Fig 16: The largest impedance resonant peaks for a flat and a trapezoid pickup, simulated in CST with the tbar (SR) mode.

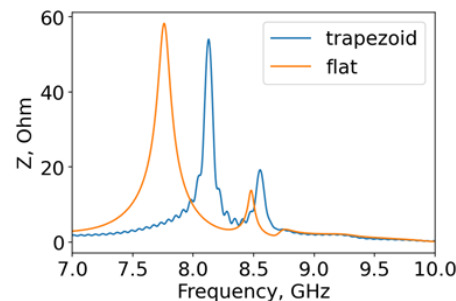

Fig 17: The initial voltage signal over time for a flat and a trapezoid pickup, simulated in CST with the tbar (SR) mode.

# Geometrical Studies: Non-Standard Geometries

- A study by A. Novokhatski suggested that **elliptical buttons** had a smaller wake-loss factor than round buttons of the same area [3].
- In CST, I simulated elliptical buttons of various ratios with FCC-ee beam parameters and beam pipe. The results suggest a reduced wake-loss factor for ellipses with a longer axis along z axis. There was negligible impact on voltage results.

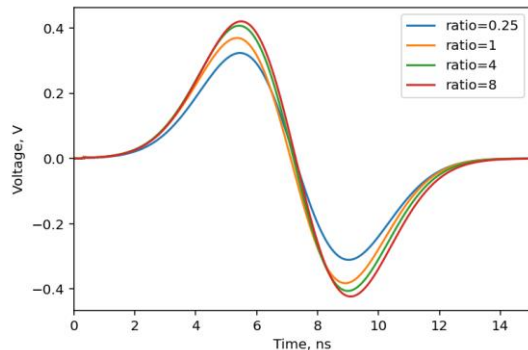

Fig 18: Voltage signal simulated after a 75 MHz filter for different ratio ellipses.

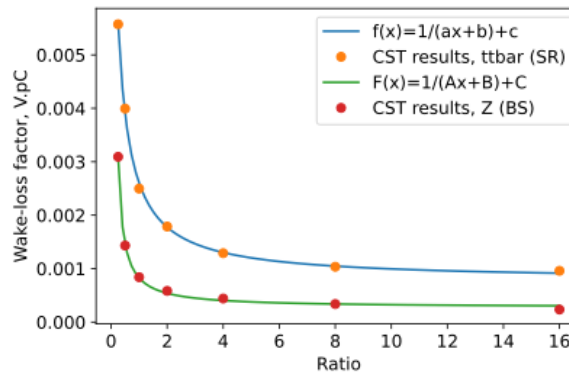

Fig 19: Wake loss factors for different ratio elliptical buttons for ttbar and Z modes.

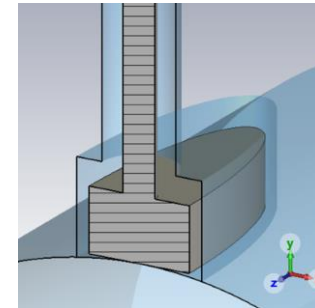

Fig 20: Elliptical button with ratio 4 modelled in CST, sliced at  $z=0$ .

## Geometrical Studies: Non-Standard Geometries

- The wake potential was smaller to start for larger ratios, but rang for longer.
- This could cause issues if the wake potential is still significant when the next bunch arrives – there is a 25 ns gap foreseen between bunches (equivalent to 7.5 m).

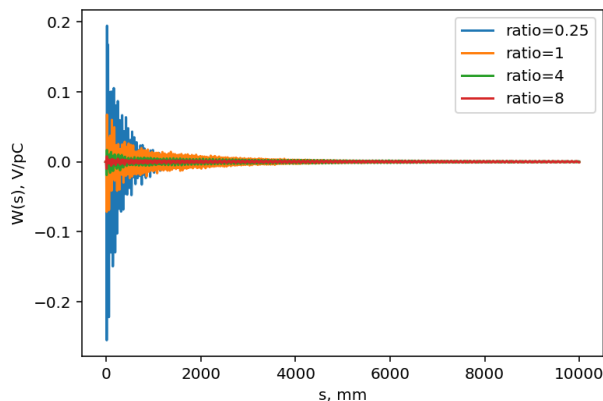

Fig 21: Wake potential simulated for different ratio ellipses over 10 m, using the ttbar mode beam parameters.

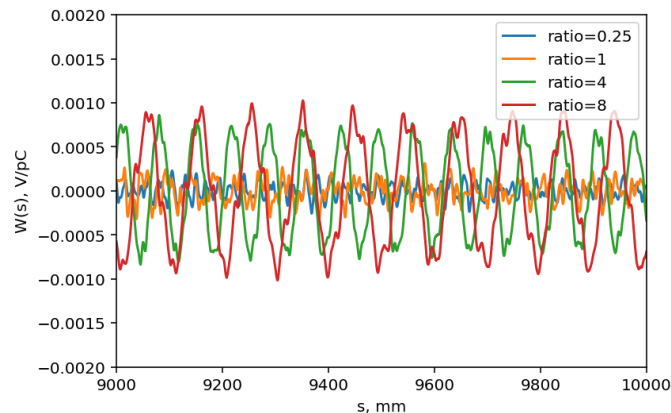

Fig 22: Ringing in wake potential simulated for different ratio ellipses between 9 and 10 m.

# Geometrical Studies: Non-Standard Geometries

- Elliptical buttons were also compared to pill-shaped and rectangular pickups, using a ratio of 4, keeping the area of the pickup the same, and using the ttbar mode.
- The rectangle had the lowest wake-loss factor – but would sharp corners cause heating issues?

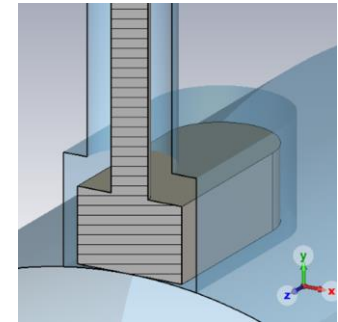

Fig 23: Pill-shaped button with ratio 4 modelled in CST, sliced at  $z=0$ .

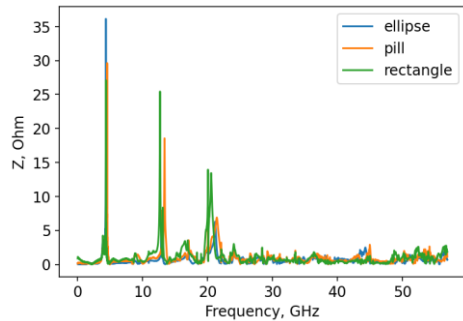

Fig 24: The wake impedance spectrum of different non-circular pickups.

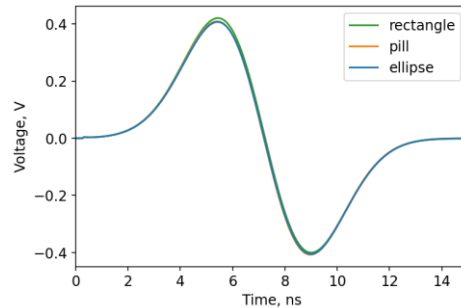

Fig 25: The voltage after a 75 MHz filter of different non-circular pickups.

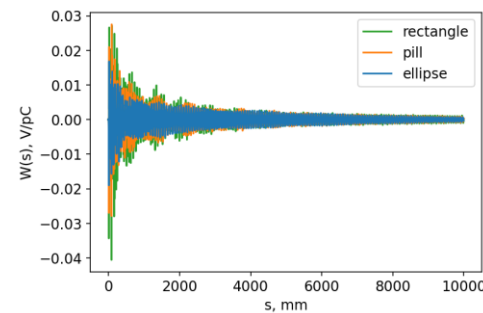

Fig 26: The wake potential of different non-circular pickups.

Shape	Wake-loss factor, V/pC
Ellipse	1.29E-03
Pill	1.38E-03
Rectangle	1.01E-03

Table 3: The wake-loss factor of different non-circular pickups.



# THERMAL STUDIES



# Thermal Studies

- Due to the **high beam intensities** expected in FCC-ee during runs with the Z mode, it is vital to model the BPM **heating**, to ensure it remains within acceptable limits.
- The first model submitted for power loss and thermal simulations is shown in Fig 16. The thermal studies suggested this would reach temperatures well beyond the acceptable limit.
- The BPM was redesigned as shown in Fig 17. The seal material was changed to alumina as this has higher thermal conductivity than borosilicate glass.

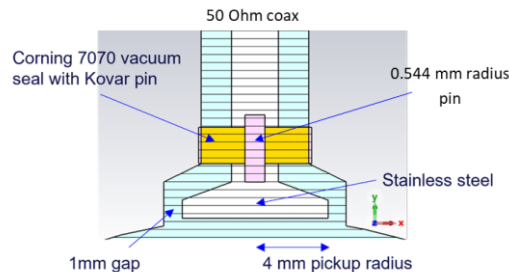

Fig 27: A cross-section of the initial pickup model used in thermal studies.

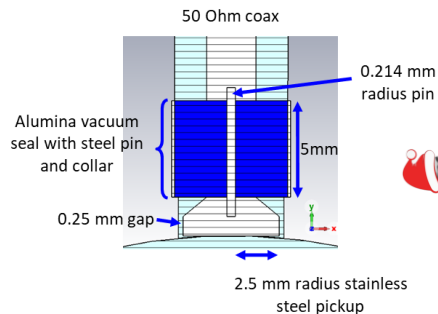

Fig 28: A cross-section of the improved pickup model used in thermal studies.

Pickup radius, mm	Seal material	Max temp, °C	Filtered output in ZH mode, $V_{pp}$
4	glass	1148	0.308
4	alumina	1042	0.166
2.5	glass	384	0.107
2.5	alumina	265	0.0569



Table 4: Results from simulating different pickups. The voltage is after a 75 MHz filter, and the temperature is from simulations of the Z mode.



# BENCH-MARKING



# Bench-marking

- Tests of an existing BPM at AWAKE have been used to benchmark CST results against measurements with beam.
- The result is shown in Fig. 19. The peak to peak voltage is similar but significantly more ringing is present in the measured signal. This could be due to structures not included in the simulation.
- Other benchmarking measurements have been taken at SwissFEL and CLEAR.

Data Set	Peak to peak Voltage, V
CST with no compensation	21.69
CST with cable response	0.57
CST with cable and oscilloscope responses	0.21
Measured eBPM at AWAKE	0.26

Table 5: Summary of the CST and AWAKE eBPM benchmarking.

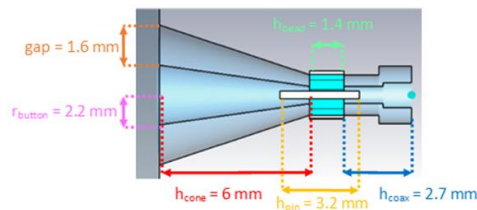

Fig 29: Cross-section of the CST model of the AWAKE eBPM. Model courtesy Bethany Spear.

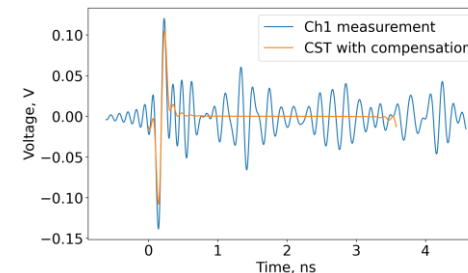

Fig 30: Measured voltage response over time of AWAKE eBPM compared with CST results, compensated for the cable and oscilloscope responses.

# Conclusions

## Summary

- Thermal simulations show that beam-induced heating will be significant in the Z mode operation, but could be mitigated by optimising the pickup geometry and selecting an insulator material with high thermal conductivity.
- Geometry of the button has a significant impact on performance – for now a trapezoidal button is favoured, but other more ‘non-standard’ designs are being explored.

## Future Work

- Further iterations of design modifications and thermal studies will be undertaken and data from additional benchmarking measurements will be analysed.
- Once studies converge to a promising model, prototypes will be built and tested both in the laboratory and with beam.

# Thank you for your attention! Merry Christmas!

Other developments during my doctoral studentship...



Joined a fanfare band on the sousaphone



Sang about science at the Ri



Learned the alphorn



Discovered sledding in Switzerland is more hardcore than in the UK...

# References

1. M. Wendt, “A brief introduction to beam position monitors for charged particle accelerators,” IEEE Instrumentation and Measurement Magazine, vol. 24, no. 9, pp. 21–32, Dec. 2021, issn: 19410123. doi: 10.1109/MIM.2021.9620043.
2. A. Abada et al., “FCC-ee: The Lepton Collider,” CERN, Geneva, Switzerland, 2019
3. A. Novokhatski, F. Franesini, M. Boscolo, et al., “JACOW : The design and electromagnetic analyses of the new elements in the FCC-ee IR vacuum chamber,” JACoW IPAC, vol. 2024, WEPR18, 2024. doi: 10.18429/JACOW-IPAC2024-WEPR18. [Online]. Available: <https://cds.cern.ch/record/2913547>.