



# **Projected Sensitivity of the XLZD Rare Event Observatory to New Physics via Low Energy Electron Recoils**

**Huan Zhang, on behalf of the XLZD collaborations**

# XLZD Detector *[simulation]*

Water Tank with PMTs  
[reduce muon flux & shield gamma ray]

Vertical electric field:  
an anode within gas layer &  
a cathode at the bottom of TPC

Gate grid located under the surface of LXe

Outer Detector with PMTs [veto neutron]

LXe Skin with PMTs

Double layer cylindrical vessel

Time projection chamber (TPC)  
with Top and Bottom arrays of PMTs  
Diameter: ~ 3m  
Height: ~ 3m  
'Nominal' 60T active LXe

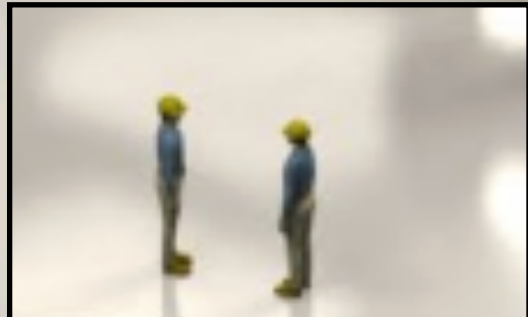
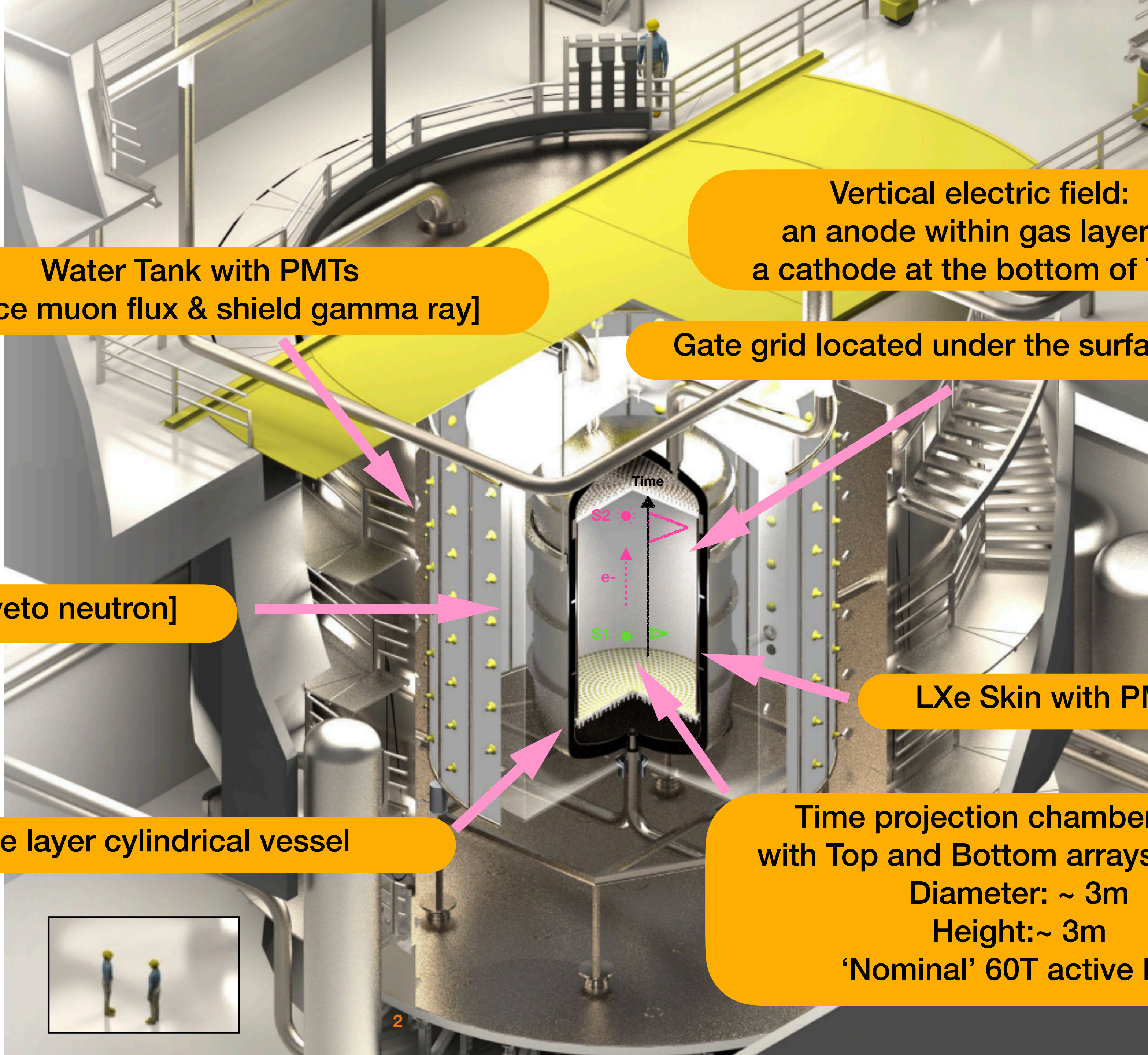

Picture from XLZD@BOULBY

# XLZD Design Ongoing

- In this talk, I will show XLZD projected sensitivity to five new physics models scattering with the target through low energy electron recoils (Low-E-ER).

<b>Signal from the sun</b>	Solar Axion	Solar Neutrino	
<b>Dark matter candidates</b>	Axion-like-Particle	Hidden Photon	Mirror dark matter

- This presentation is hypothetical XLZD design with 300 tonne-year exposure.

# XLZD Analysis Framework

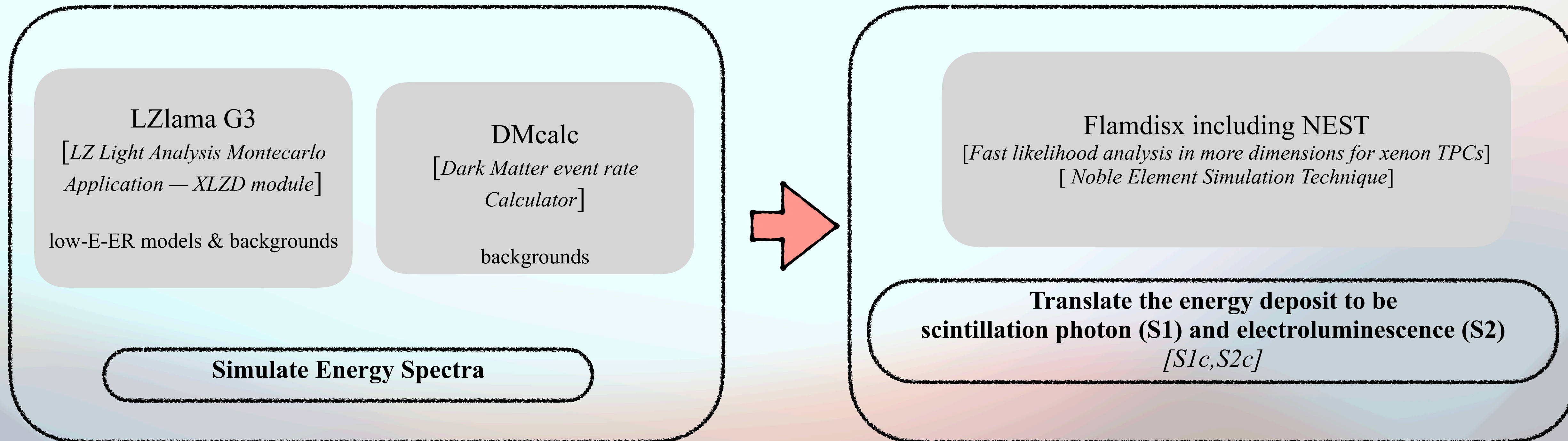

# XLZD Statistic Scheme

## FlameFitSimple including Flamdisx

Probability distribution functions (PDFs)  
in the form of s1c and s2c



Likelihood function



Test-Statistics

500 Toy datasets + profile likelihood ratio (PLR)



Sensitivity

P-value

Methodology

(default coupling constant/projected coupling constant)<sup>n</sup> = simulated rate/projected rate



Median 90% C.I.



**IOP**  
Institute of Physics



# **Backgrounds in Low-E-ER group**

# Simulated Backgrounds

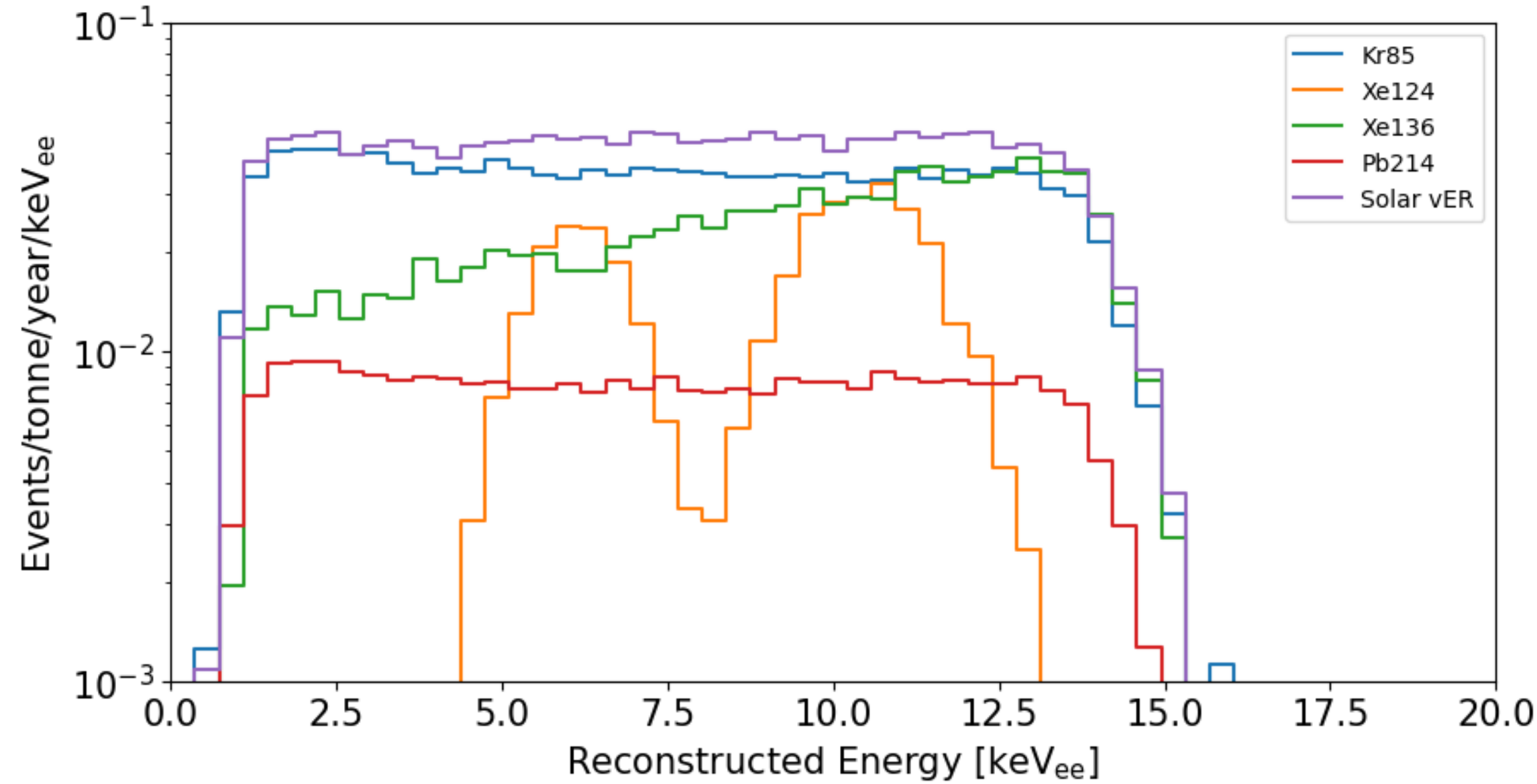

ROI [same for Low-E-ER models]

$0 < cS1 < 100$  phe

$2 < \log_{10}(cS2[\text{phe}]) < 5$

4-fold coincidence

Background	Spectrum	Counts [event/ty]	Counts [fraction of solar vER]
Pb214	Normalisation: <i>Haselschwardt, S. J., Joel Kostensalo, Xavier Mougeot, and Jouni Suhonen. Physical Review C 102, no. 6 (2020): 065501.</i> Shape: taken from LZ simulations	5.2	0.19
Kr85	Normalisation: $T_{1/2} = 10.76$ yr; $2 \times 10^{-11}$ isotopic abundance; 99.6% ground-state branching ratio Shape: taken from LZ simulations	23.1	0.83
Xe136 $2\nu\beta\beta$	Normalisation: <i>Albert, J. B., M. Auger, D. J. Auty, P. S. Barbeau, E. Beauchamp, D. Beck, V. Belov et al. Physical Review C 89, no. 1 (2014): 015502.</i> Shape: taken from LZ simulations	13.5	0.49
Xe124 $2\nu\text{DEC}$	Normalisation: <i>Aprile, E., K. Abe, F. Agostini, S. Ahmed Maouloud, M. Alfonsi, L. Althueser, B. Andrieu et al. Physical Review C 106, no. 2 (2022): 024328.</i> Shape: taken from LZ simulations	6.0	0.27
Solar vER(PP+7Be+CNO)	From DMCalc (LZ)	27.8	1.00

# Simulated Backgrounds

Pb214: 5.2 counts / ty

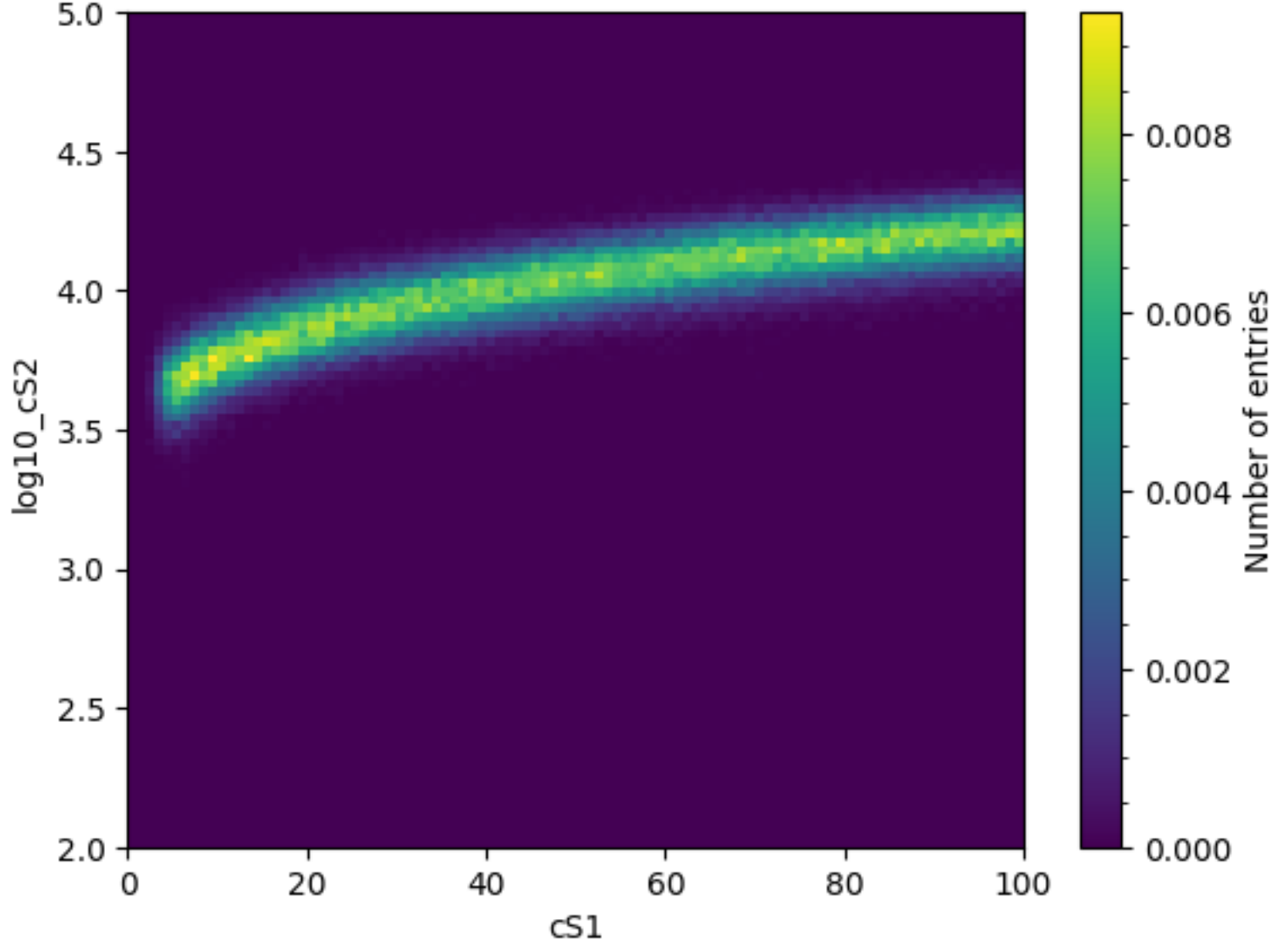

Kr85: 23.1 counts / ty

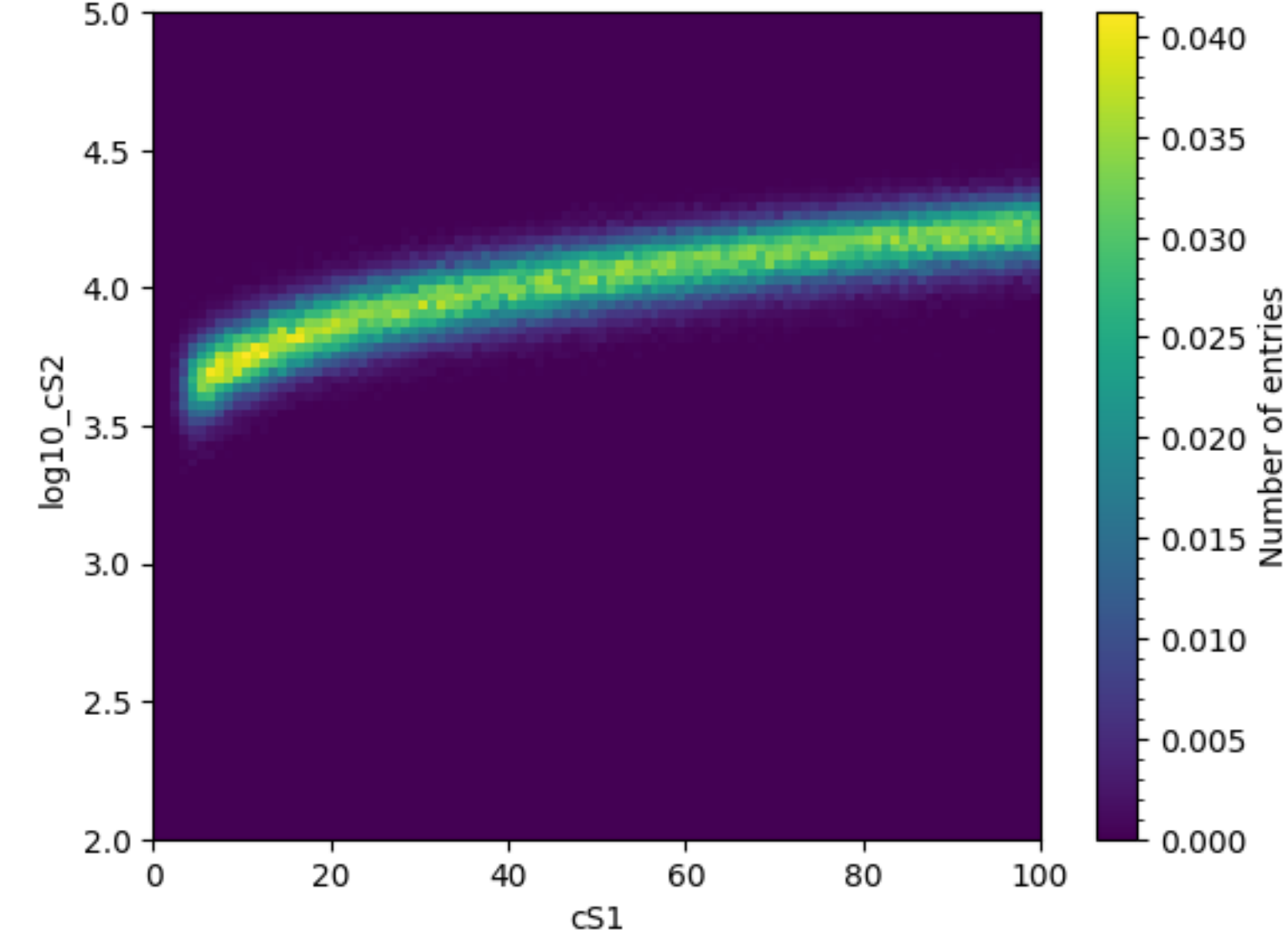

Solar vER: 27.8counts / ty

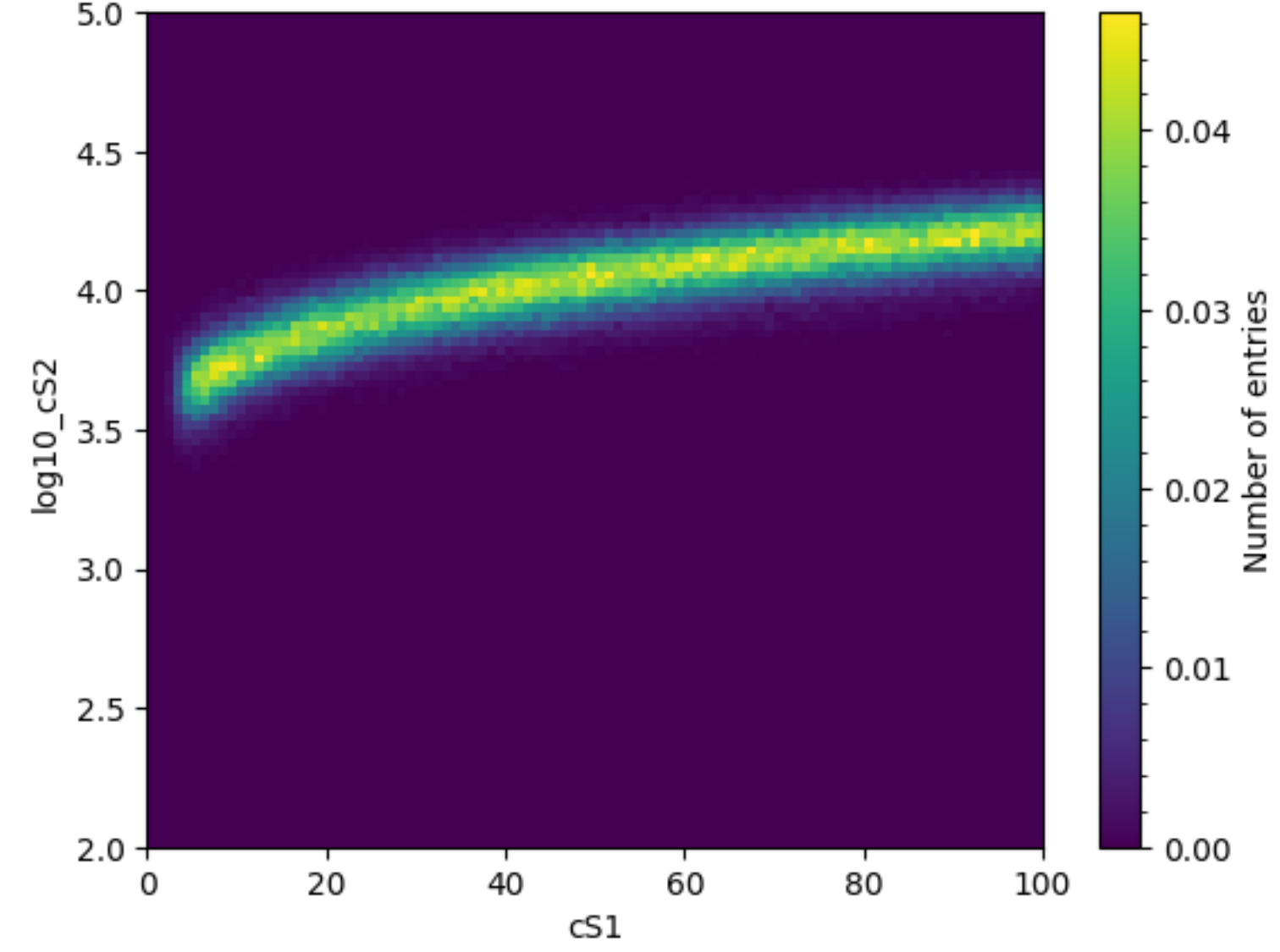

Xe124: 6.0 counts / ty

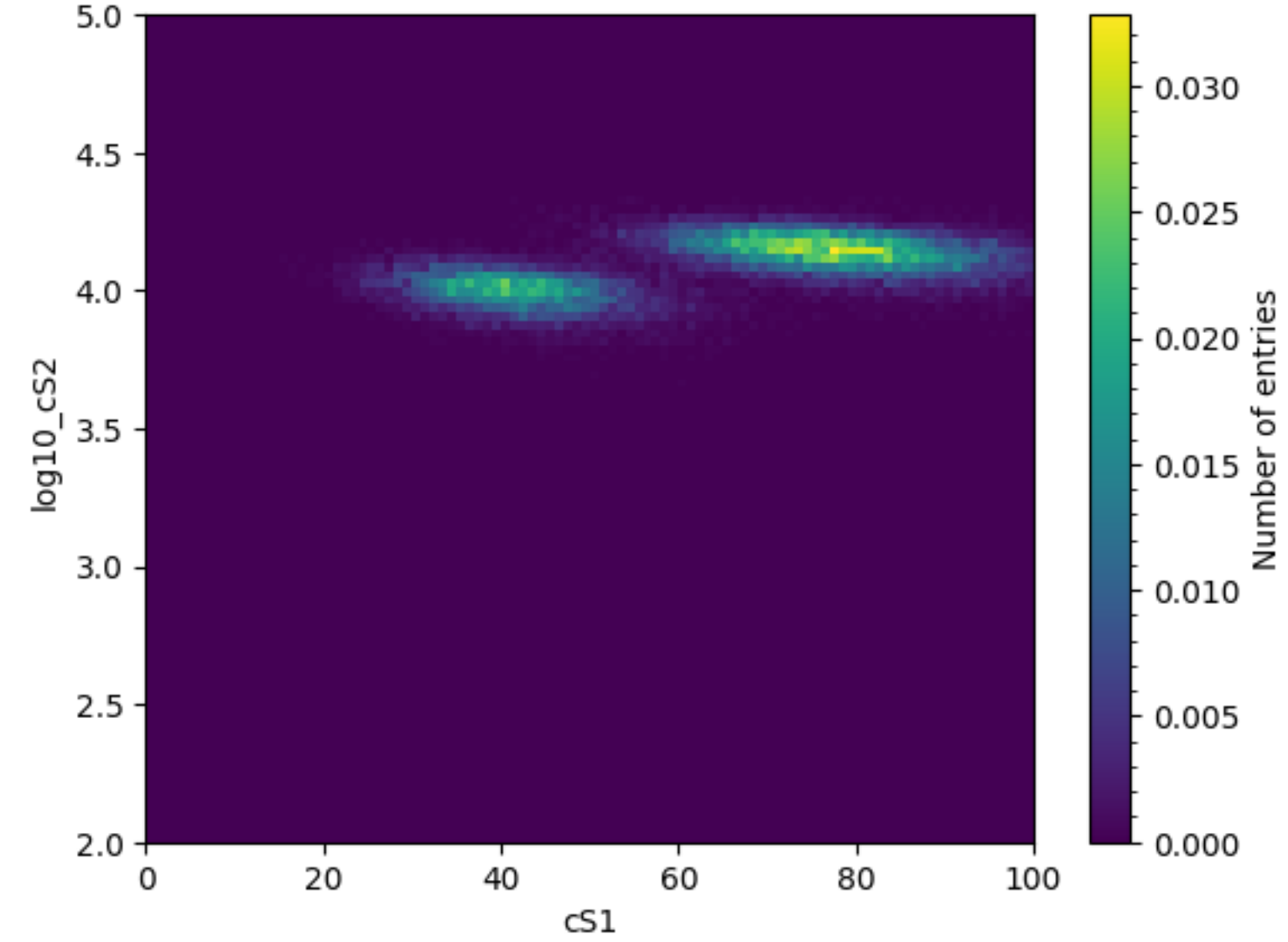

Xe136: 13.5 counts / ty

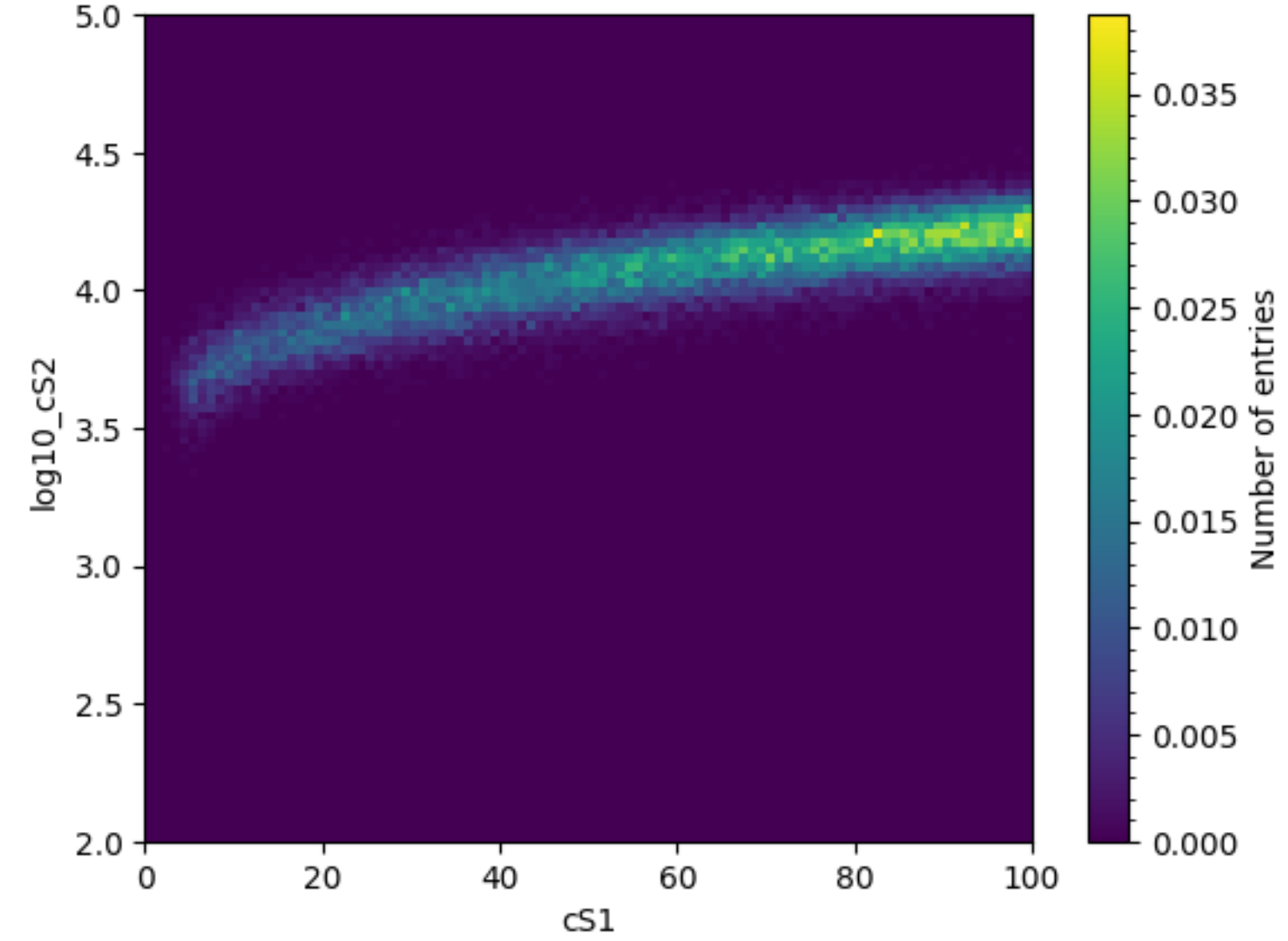



**IOP**  
Institute of Physics



# Physics Models in Low-E-ER Group

# Solar Axion

## Hypothetical Pseudoscalar Bosons

### Solar Axion flux

#### Atomic, Bremsstrahlung and Compton effects

#### Coupling constant $g_{ae}$

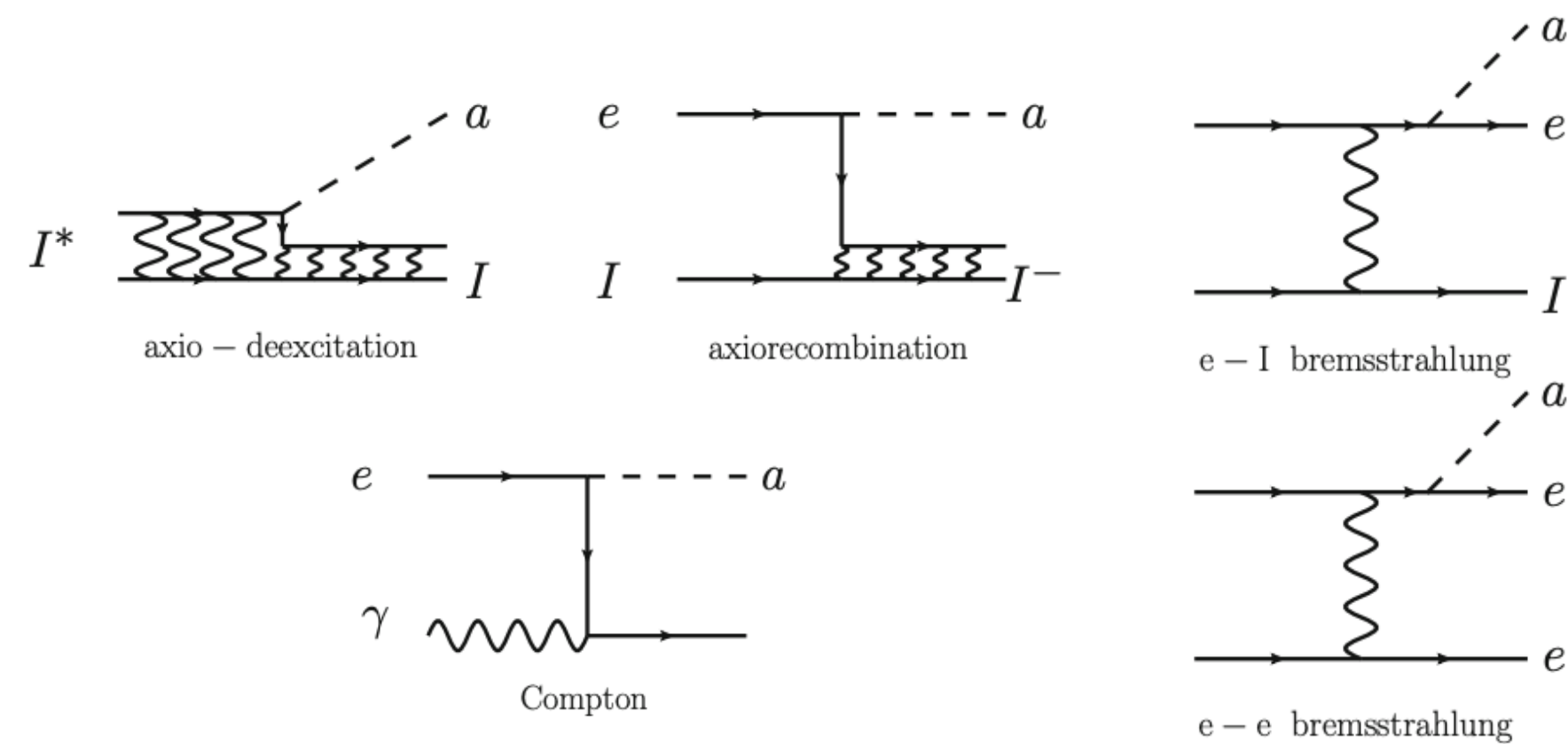

### Solar Axion detection

#### Axioelectric coupling process

#### Coupling constant $g_{ae}$

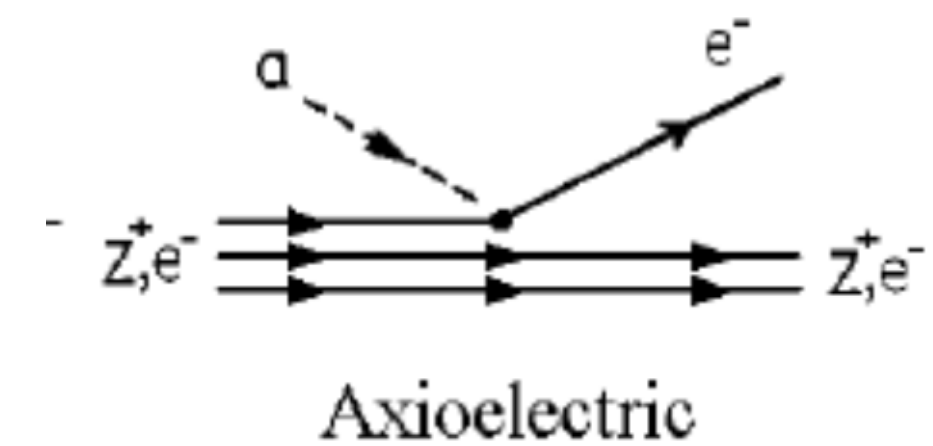

# Sensitivity of Solar Axion $g_{ae}$

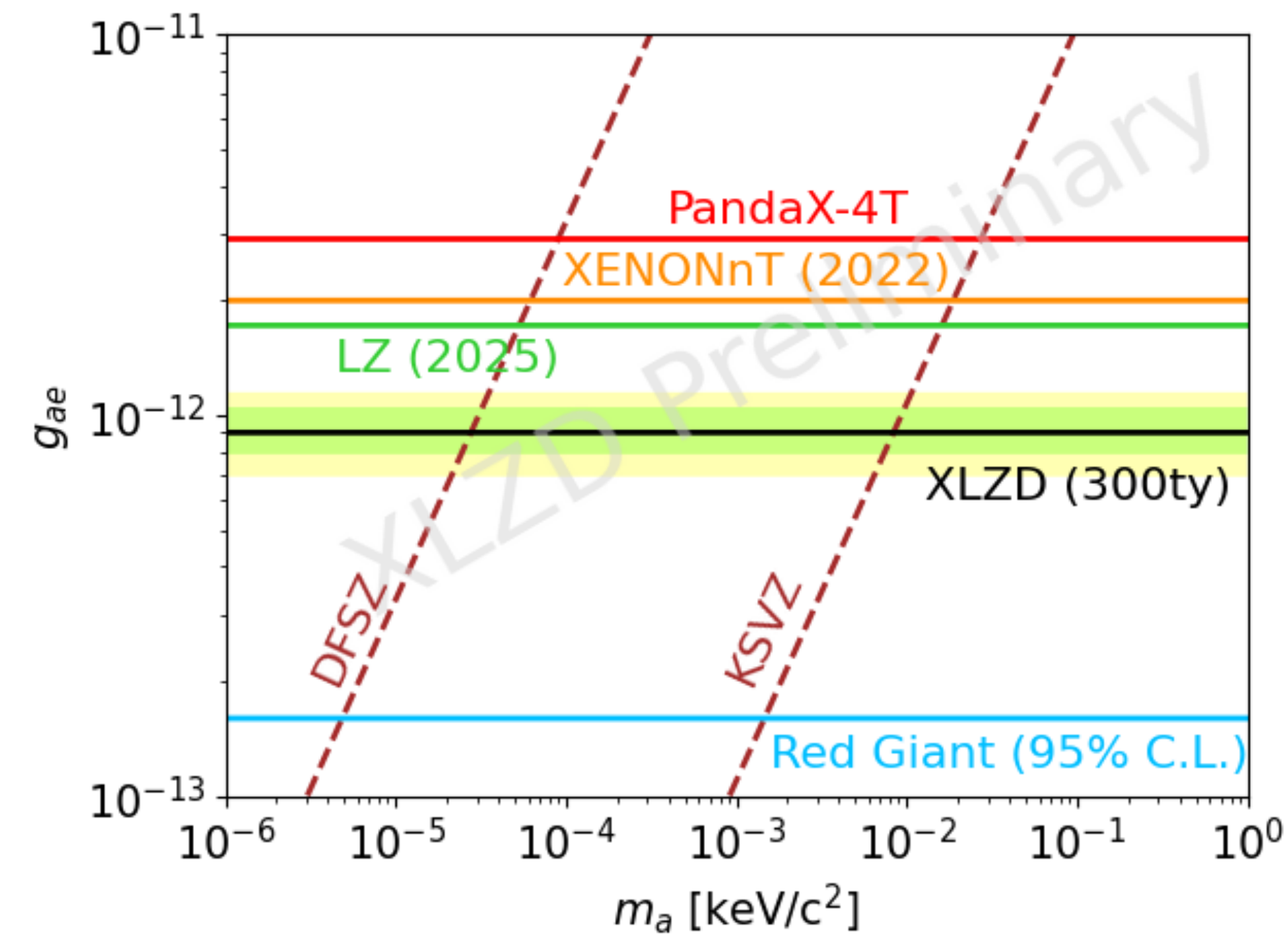
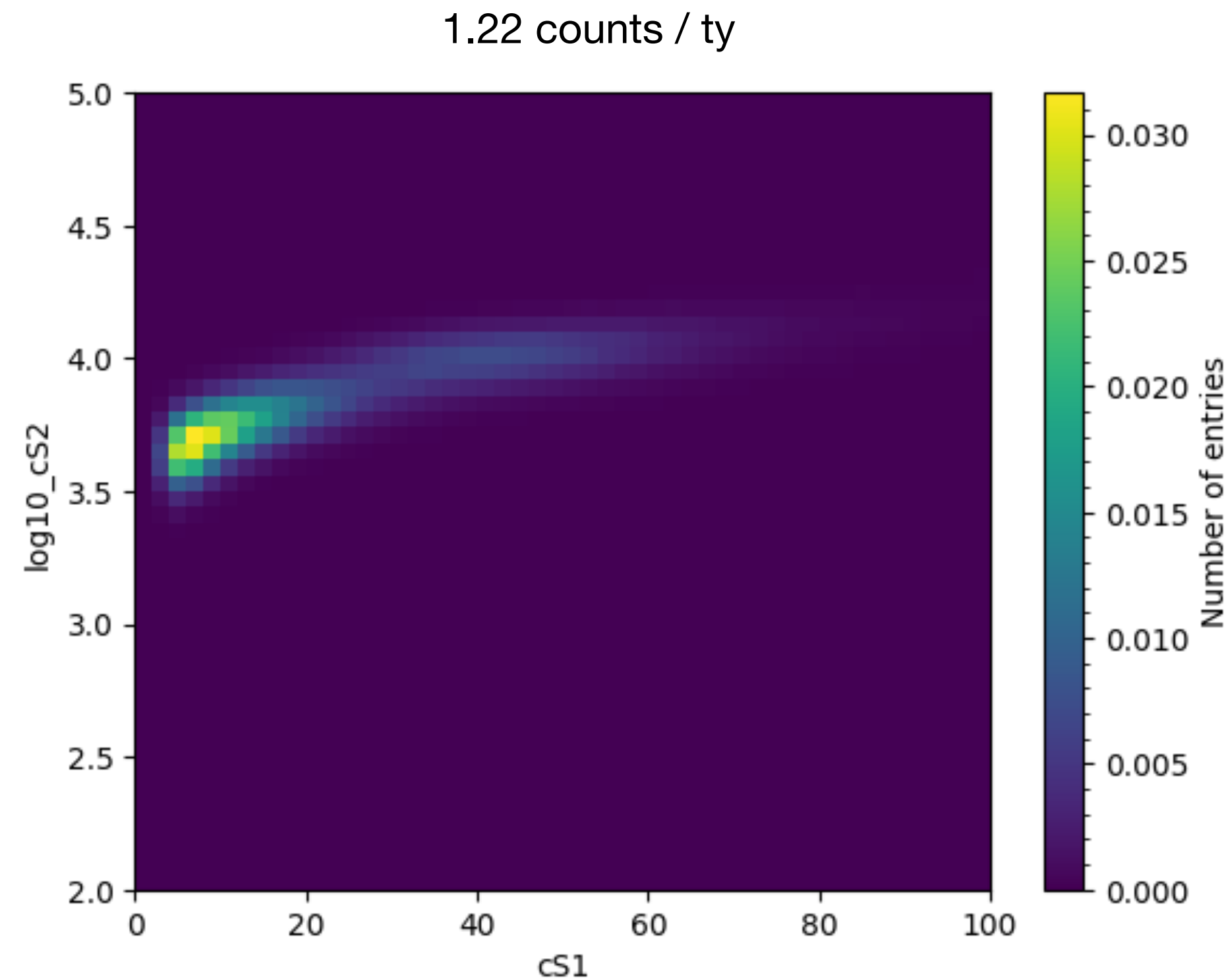

More information can be found:

[Redondo, Javier. \*Journal of Cosmology and Astroparticle Physics\* 2013, no. 12 \(2013\): 008-008.](#)

[Akerib, D. S., and LZ Collaboration. \*arXiv preprint arXiv:2511.17350\*.](#)

[E. Aprile et al. \(XENON\), \*Phys. Rev. Lett.\* 129, 161805 \(2022\), \*arXiv:2207.11330 \[hep-ex\]\*.](#)

[X. Zeng et al. \(PandaX\), \*Phys. Rev. Lett.\* 134, 041001 \(2025\), \*arXiv:2408.07641 \[hep-ex\]\*.](#)

[J. E. Kim, \*Phys. Rev. Lett.\* 43, 103 \(1979\).](#)

[M. Dine, W. Fischler, and M. Srednicki, \*Phys. Lett. B\* 104, 199 \(1981\).](#)

# Solar Axion

## Hypothetical Pseudoscalar Bosons

Solar Axion flux

Primakoff effect

Coupling constant  $g_{a\gamma}$

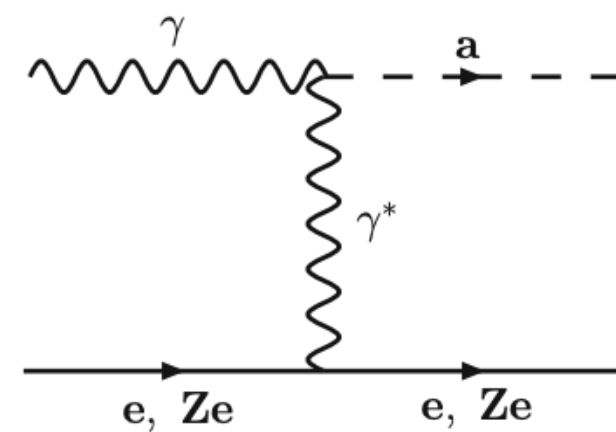

Solar Axion detection

Inverse Primakoff process

Coupling constant  $g_{a\gamma}$

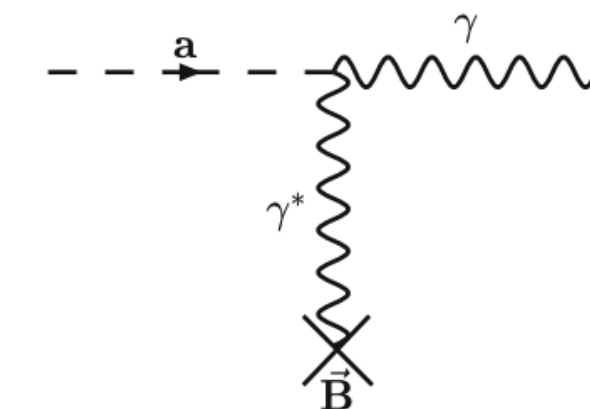

More information can be found:

*Dent, James B., Bhaskar Dutta, Jayden L. Newstead, and Adrian Thompson. Physical Review Letters 125, no. 13 (2020): 131805.*

# Sensitivity of Solar Axion $g_{a\gamma}$

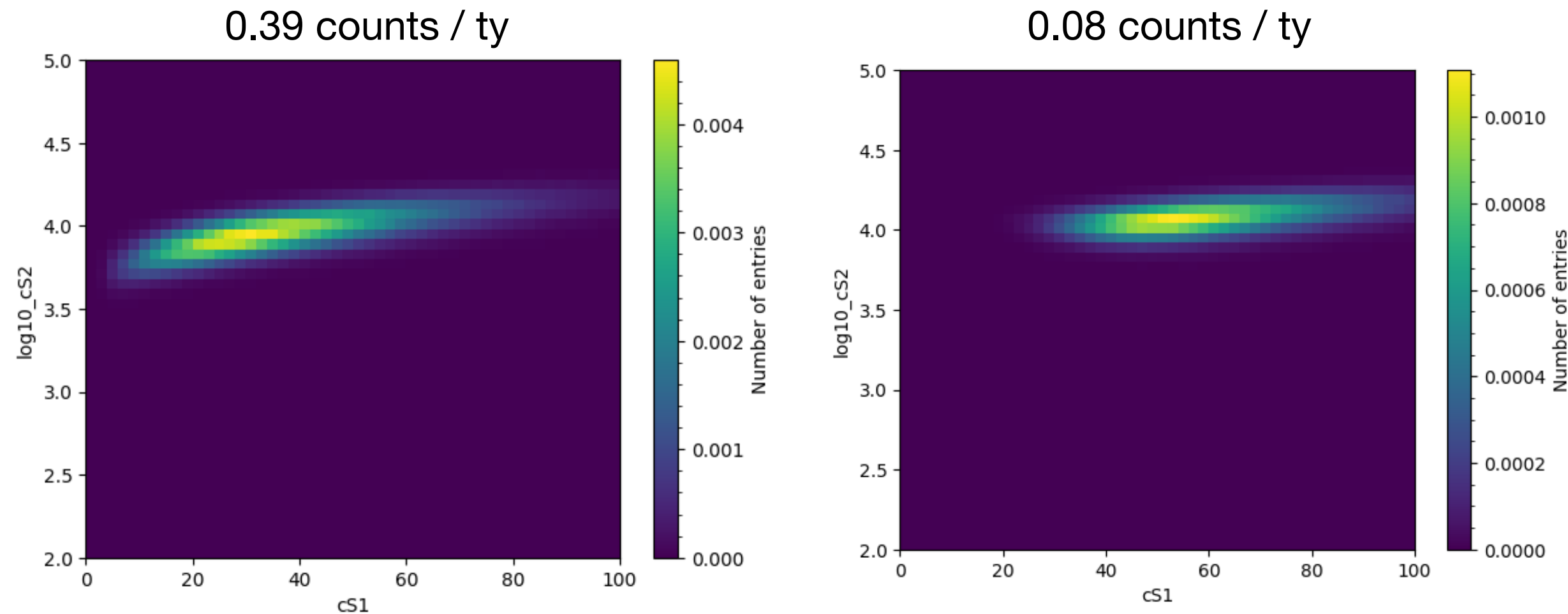

Solar Axion mass 1 keV/c<sup>2</sup>      0.004counts / ty      Solar Axion mass 5 keV/c<sup>2</sup>

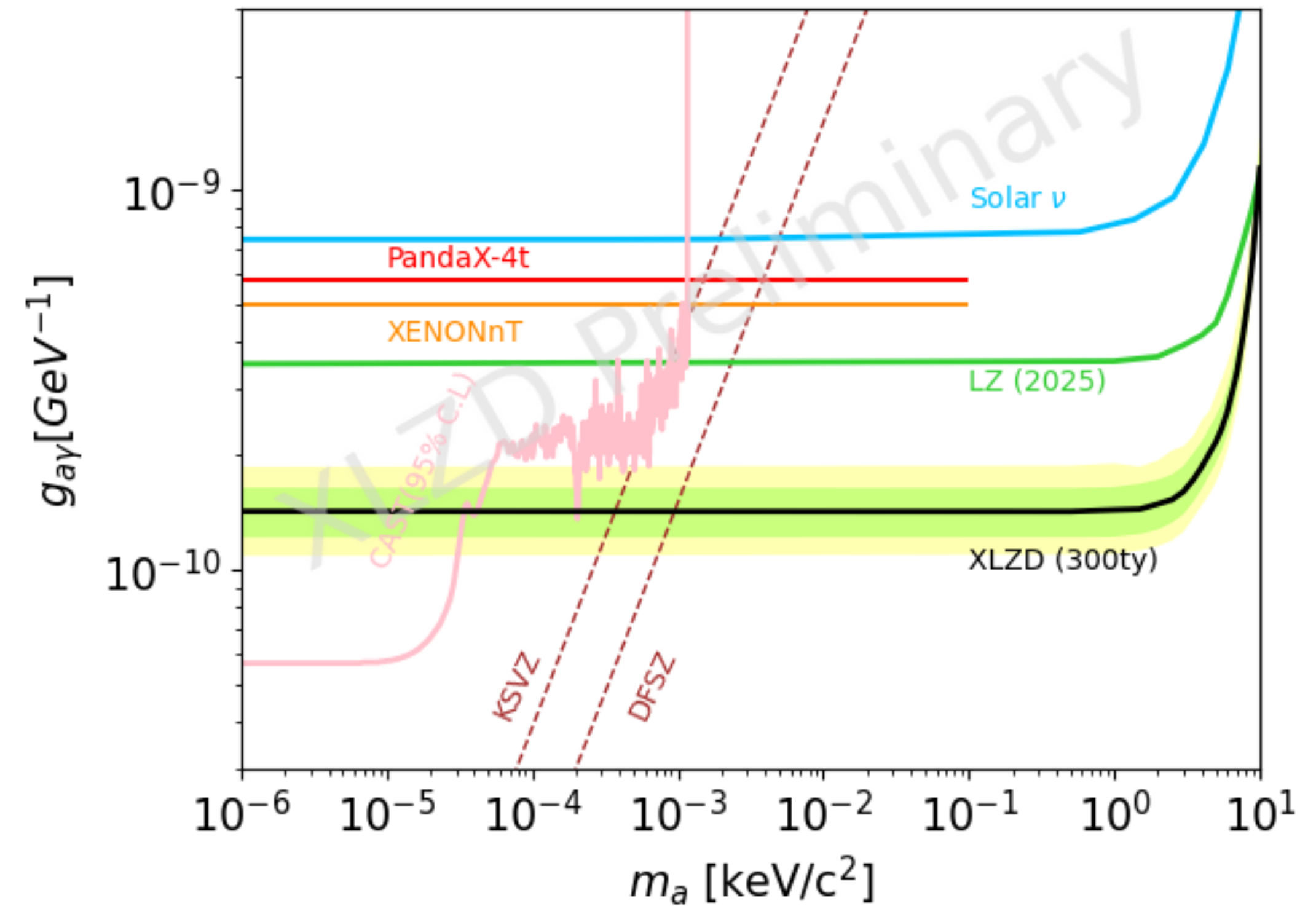
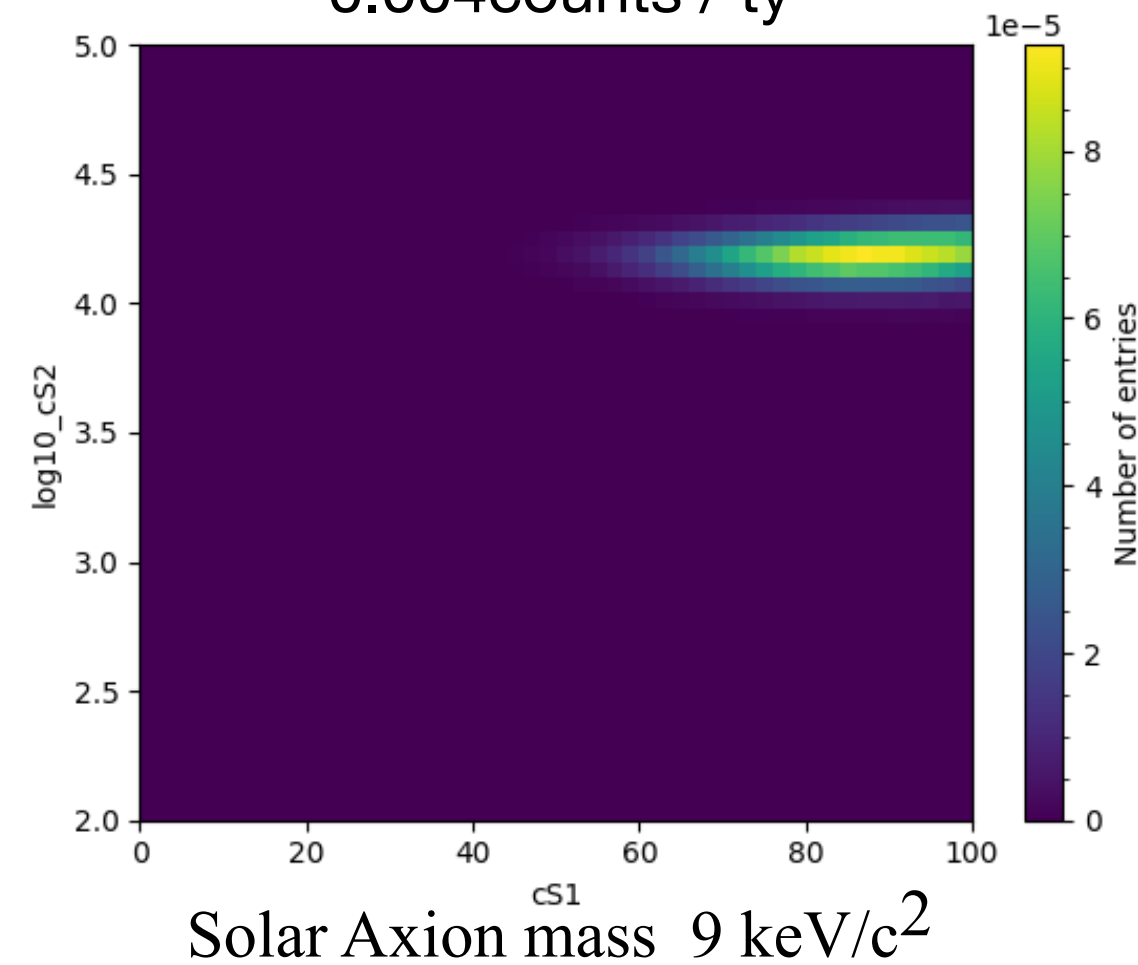

**More information can be found:**

- [Dent, James B., Bhaskar Dutta, Jayden L. Newstead, and Adrian Thompson. \*Physical Review Letters\* 125, no. 13 \(2020\): 131805.](#)
- [Akerib, D. S., and LZ Collaboration. \*arXiv preprint arXiv:2511.17350\*.](#)
- [E. Aprile et al. \(XENON\), \*Phys. Rev. Lett.\* 129, 161805 \(2022\), \*arXiv:2207.11330 \[hep-ex\]\*.](#)
- [X. Zeng et al. \(PandaX\), \*Phys. Rev. Lett.\* 134, 041001 \(2025\), \*arXiv:2408.07641 \[hep-ex\]\*.](#)
- [S. Andriamonje et al. \(CAST\), \*JCAP\* 12, 002 \(2009\), \*arXiv:0906.4488 \[hep-ex\]\*.](#)

# Solar Axion

## Hypothetical Pseudoscalar Bosons

### Solar Axion flux

$^{57}\text{Fe}$  de-excitation process

Coupling constant  $g_{aN}$

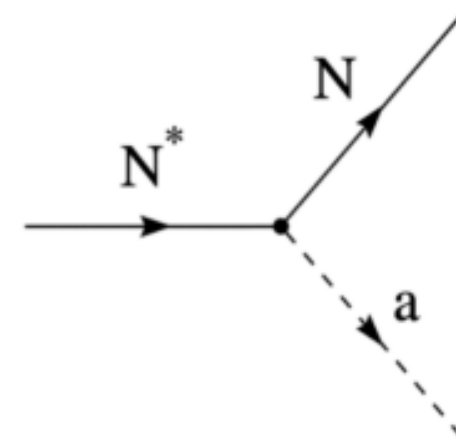

### Solar Axion detection

Axioelectric coupling & Inverse Primakoff process

Coupling constant  $g_{ae}$  &  $g_{a\gamma}$

More information can be found:

*Akerib, D. S., and LZ Collaboration. arXiv preprint arXiv:2511.17350.*

# Sensitivity of Solar Axion $g_{ae}g_{aN}$

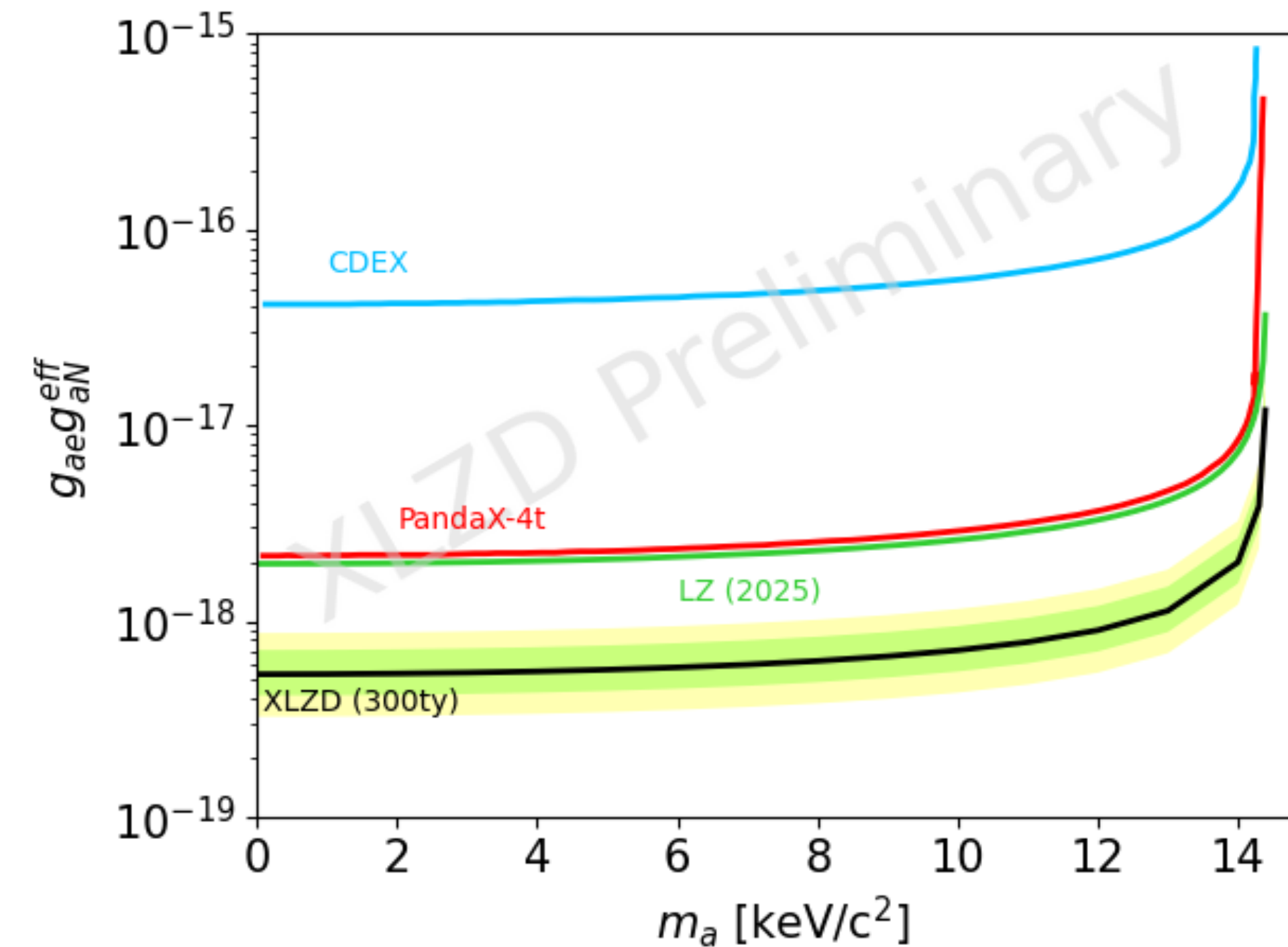
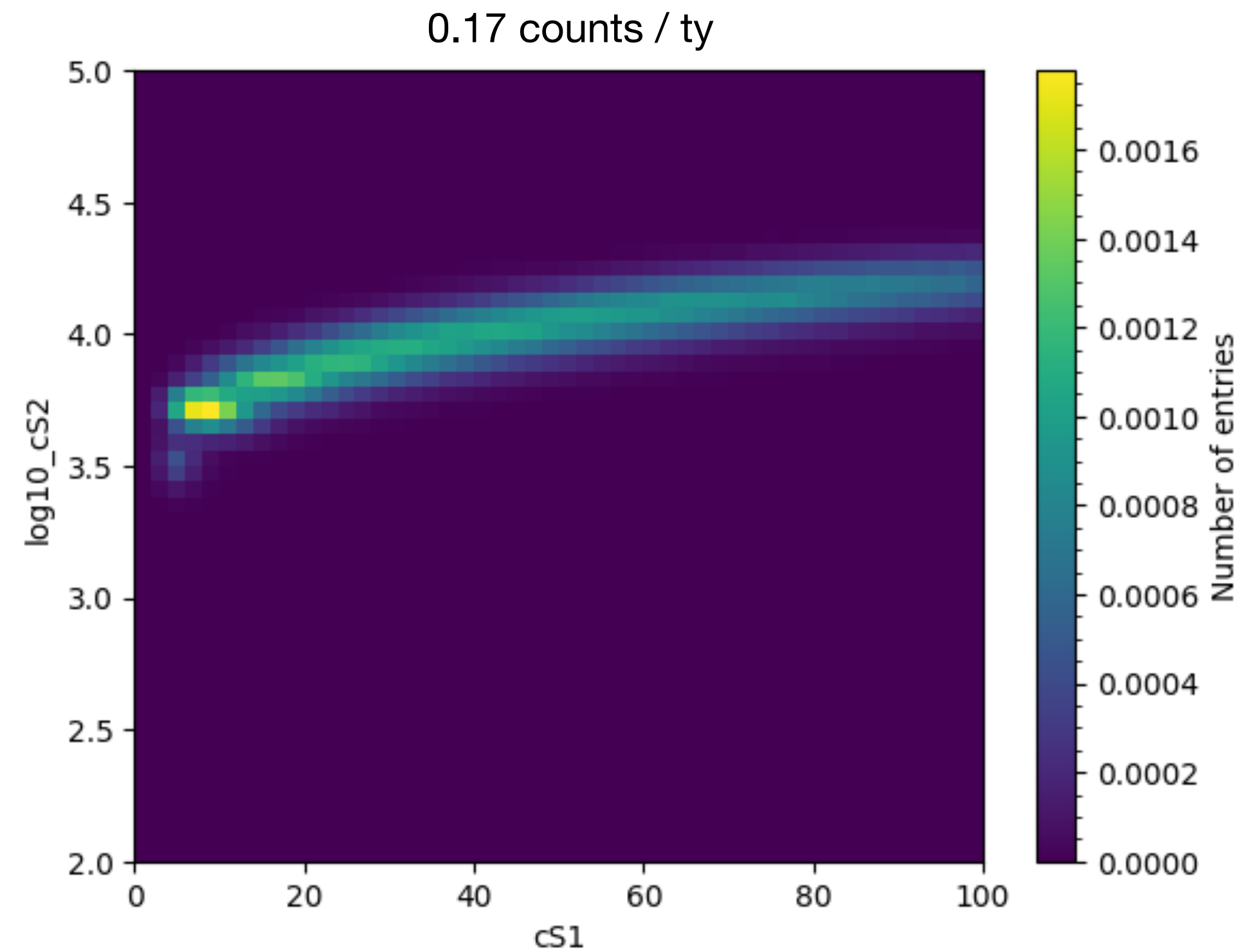

More information can be found:

*Akerib, D. S., and LZ Collaboration. arXiv preprint arXiv:2511.17350.*

*X. Zeng et al. (PandaX), Phys. Rev. Lett. 134, 041001 (2025), arXiv:2408.07641 [hep-ex].*

*Y. Wang et al. (CDEX), Phys. Rev. D 101, 052003 (2020), arXiv:1911.03085 [hep-ex].*

# Sensitivity of Solar Axion $g_{a\gamma}g_{aN}$

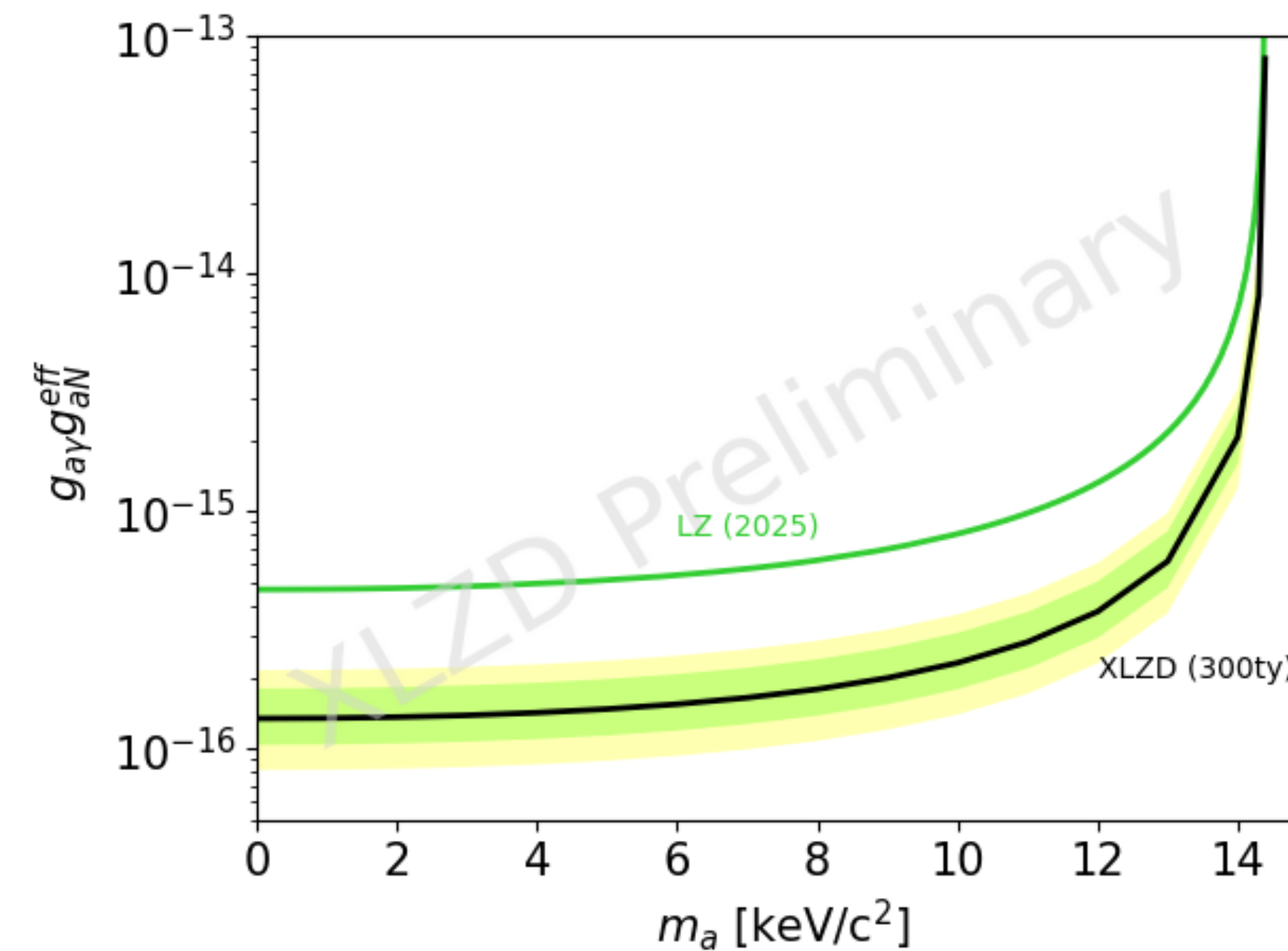
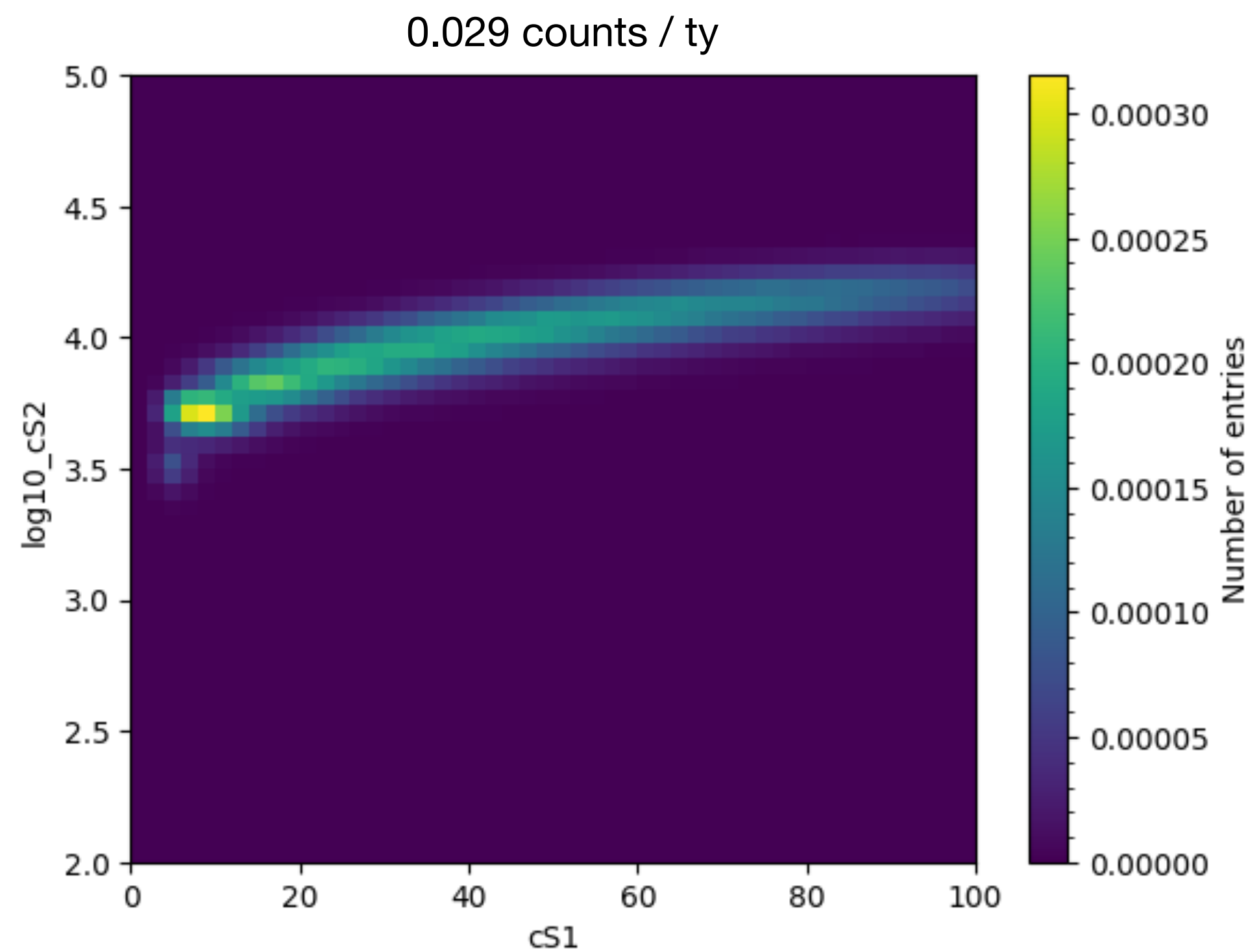

More information can be found:

*Akerib, D. S., and LZ Collaboration. arXiv preprint arXiv:2511.17350.*

# Solar Neutrino

- Neutrino electromagnetic properties: magnetic moment (NuMM) and effective milicharge (NuMQ)
- Coupling constant  $\mu_\nu$  and  $\delta$

More information can be found:

*Hsieh, Chung-Chun, Lakhwinder Singh, Chih-Pan Wu, Jiunn-Wei Chen, Hsin-Chang Chi, C-P. Liu, Mukesh K. Pandey, and Henry T. Wong. Physical Review D 100, no. 7 (2019): 073001.*

# Solar Neutrino

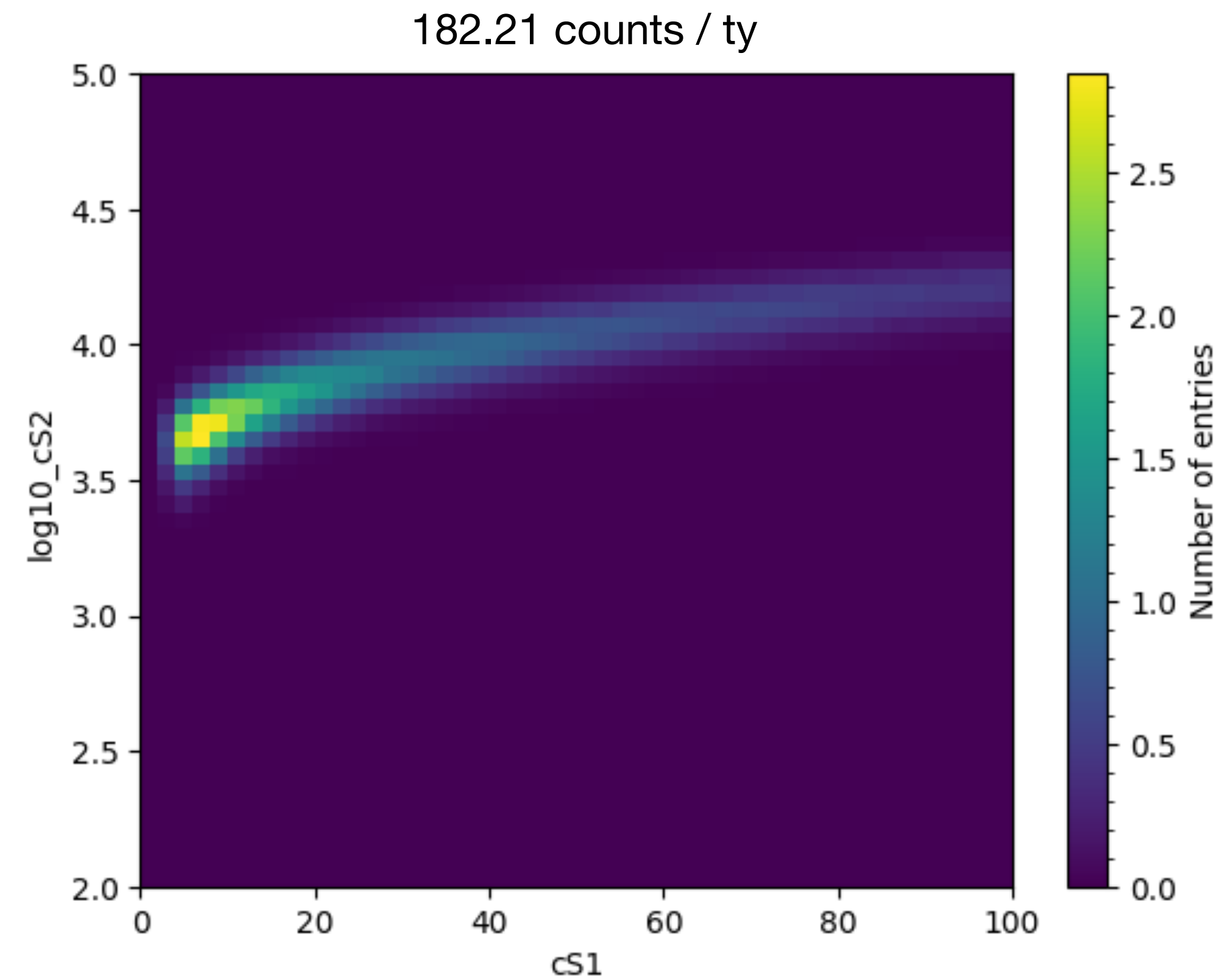

**Solar NuMM**

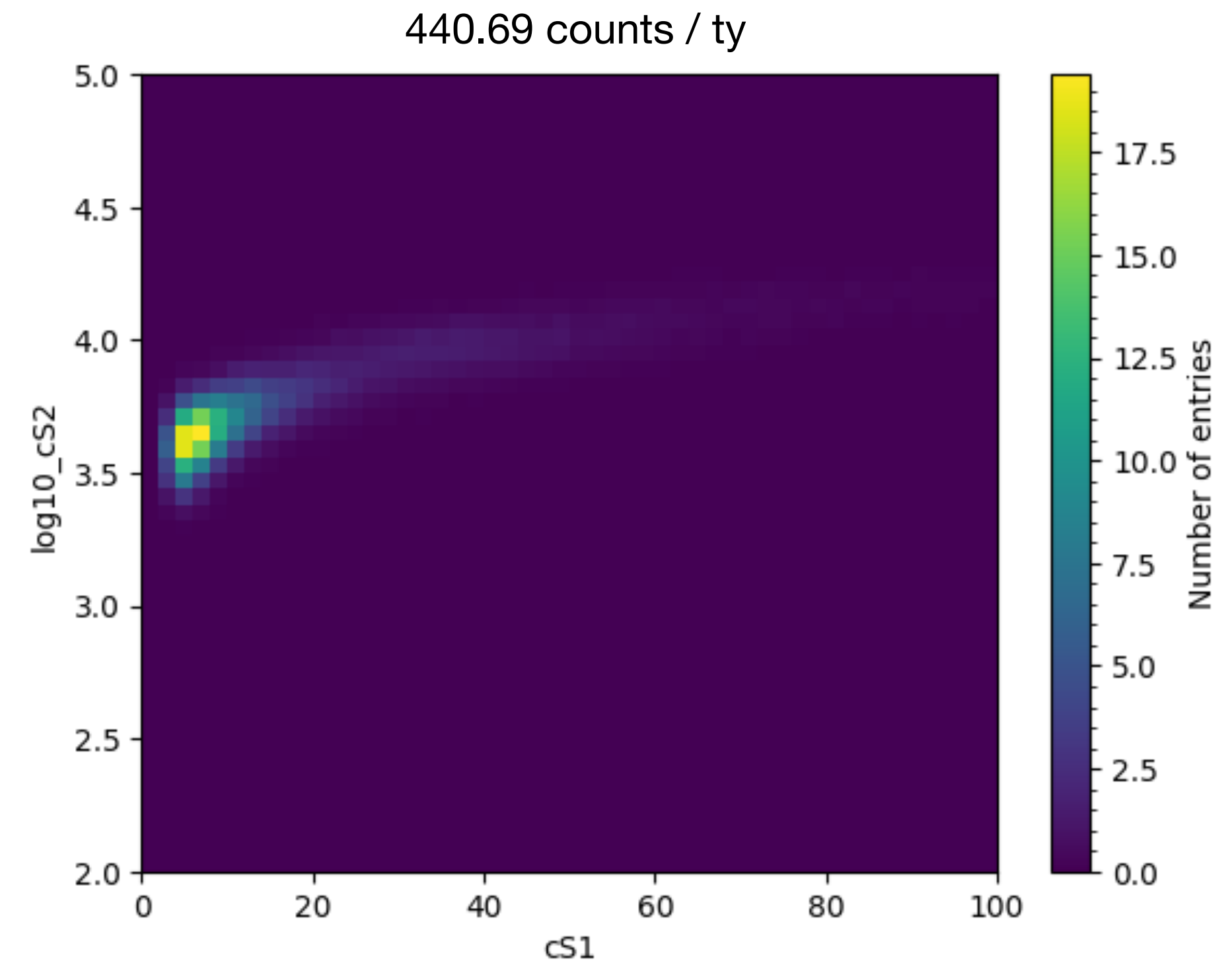

**Solar NuMQ**

More information can be found:

*Hsieh, Chung-Chun, Lakhwinder Singh, Chih-Pan Wu, Jiunn-Wei Chen, Hsin-Chang Chi, C-P. Liu, Mukesh K. Pandey, and Henry T. Wong. Physical Review D 100, no. 7 (2019): 073001.*

# Sensitivity of Solar Neutrino $\mu_\nu$ & $\delta$

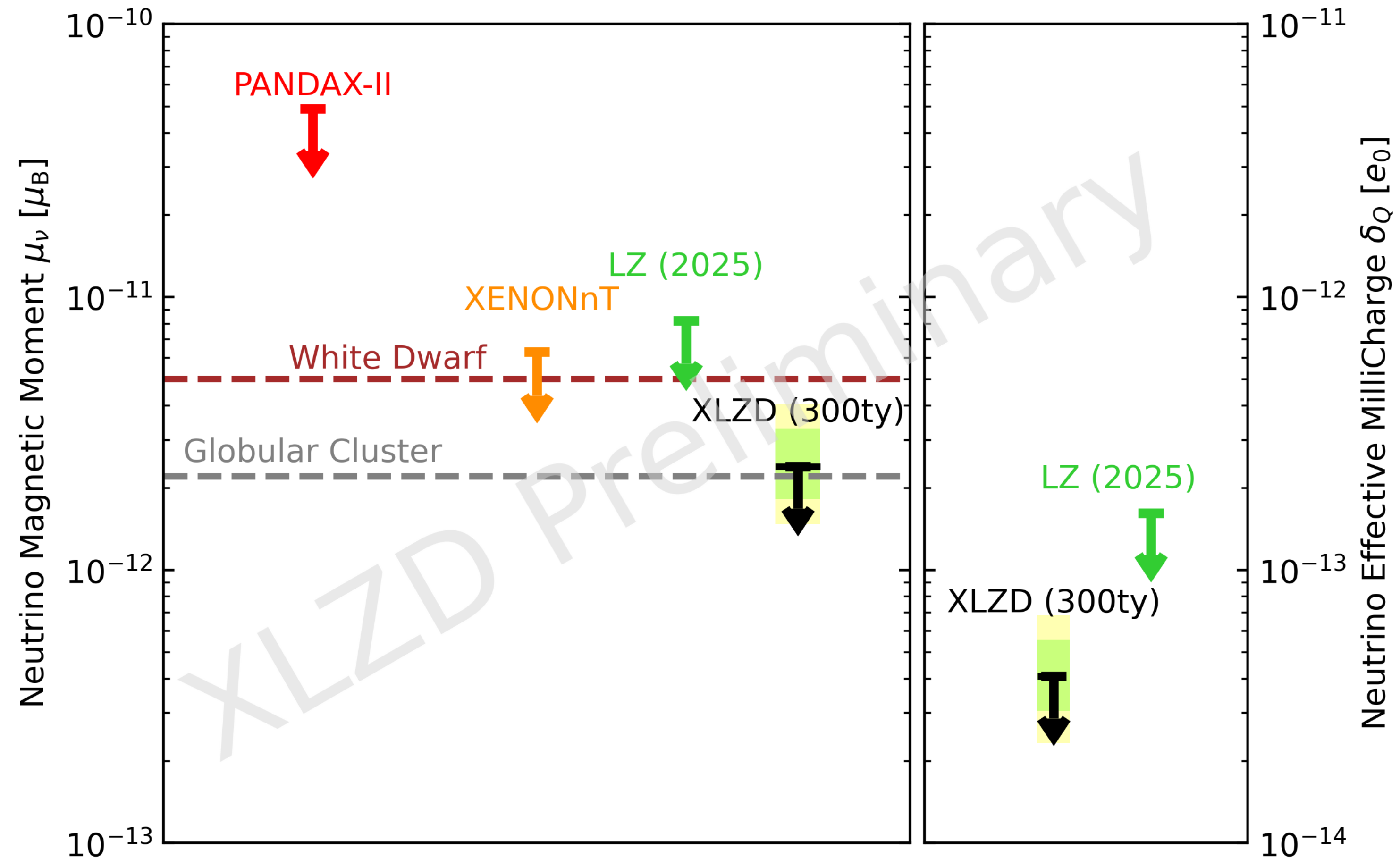

More information can be found:

*Hsieh, Chung-Chun, Lakhwinder Singh, Chih-Pan Wu, Jiunn-Wei Chen, Hsin-Chang Chi, C-P. Liu, Mukesh K. Pandey, and Henry T. Wong. Physical Review D 100, no. 7 (2019): 073001.*

*Akerib, D. S., and LZ Collaboration. arXiv preprint arXiv:2511.17350.*

*E. Aprile et al. (XENON), Phys. Rev. Lett. 129, 161805 (2022), arXiv:2207.11330 [hep-ex].*

*E. Aprile et al. (XENON), Phys. Rev. D 102, 072004 (2020), arXiv:2006.09721 [hep-ex].*

*H. Córscico, L. G. Althaus, M. M. Miller Bertolami, S. O. Kepler, and E. García-Berro, JCAP 08, 054 (2014), arXiv:1406.6034 [astro-ph.SR].*

*N. Viaux, M. Catelan, P. B. Stetson, G. Raffelt, J. Redondo, A. A. R. Valcarce, and A. Weiss, Phys. Rev. Lett. 111, 231301 (2013), arXiv:1311.1669 [astro-ph.SR].*

# Axion-Like-Particle & Hidden Photon

- ALP or HP can be absorbed by bound electrons of xenon in process analogous to photoelectric effect, but with photon energy replaced with ALP mass or HP mass
- Coupling constant  $g_{ae}$  or kinetic mixing constant  $\kappa^2$

More information can be found:

*Pospelov, Maxim, Adam Ritz, and Mikhail Voloshin. Physical Review D—Particles, Fields, Gravitation, and Cosmology 78, no. 11 (2008): 115012.*

# Mono-Energy — 10 keV

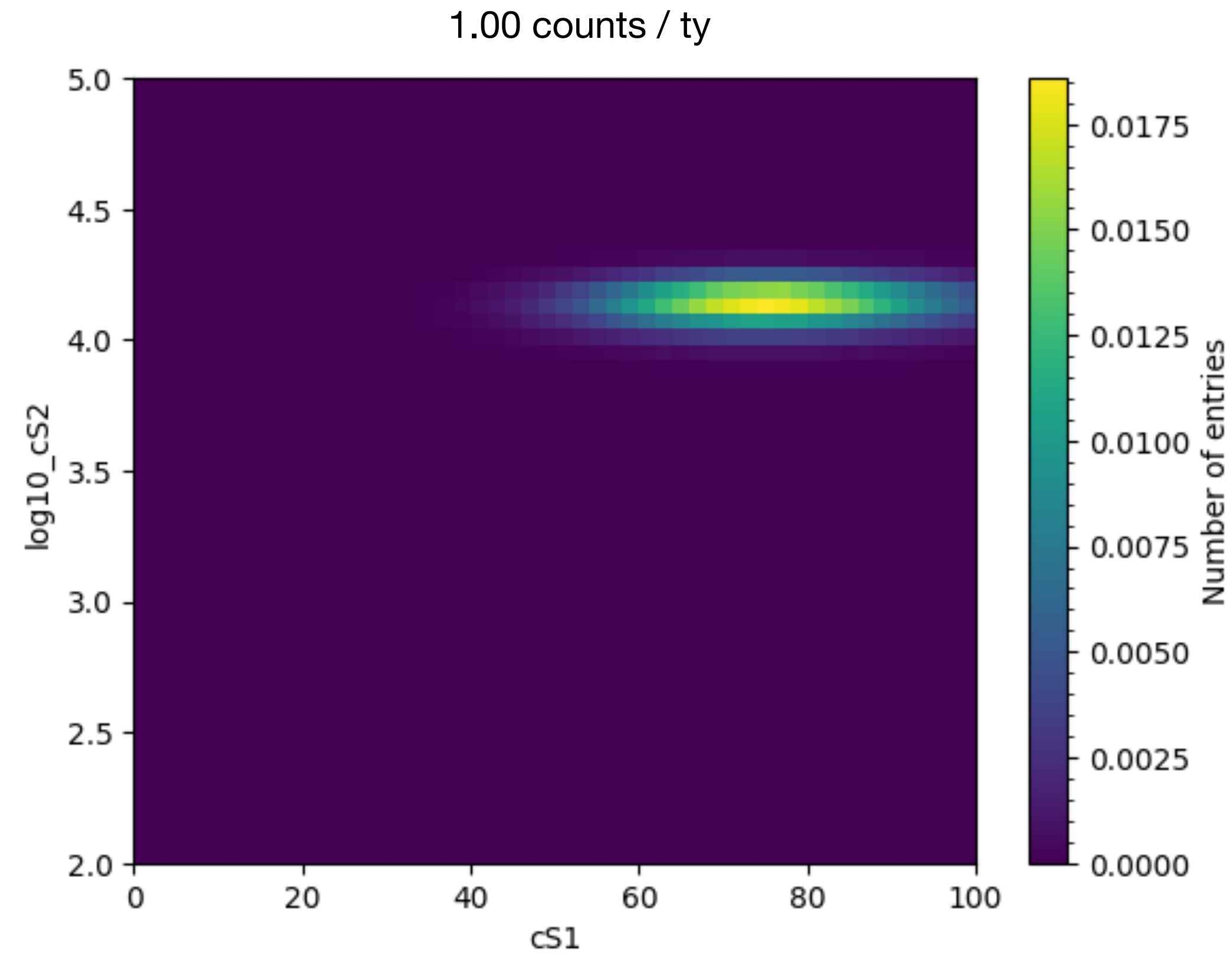

More information can be found:

*Pospelov, Maxim, Adam Ritz, and Mikhail Voloshin. Physical Review D—Particles, Fields, Gravitation, and Cosmology 78, no. 11 (2008): 115012.*

# Sensitivity of Axion-Like-Particle $g_{ae}$ & Hidden Photon $\kappa^2$

Waiting for Approval but has been allowed to present by XLZD

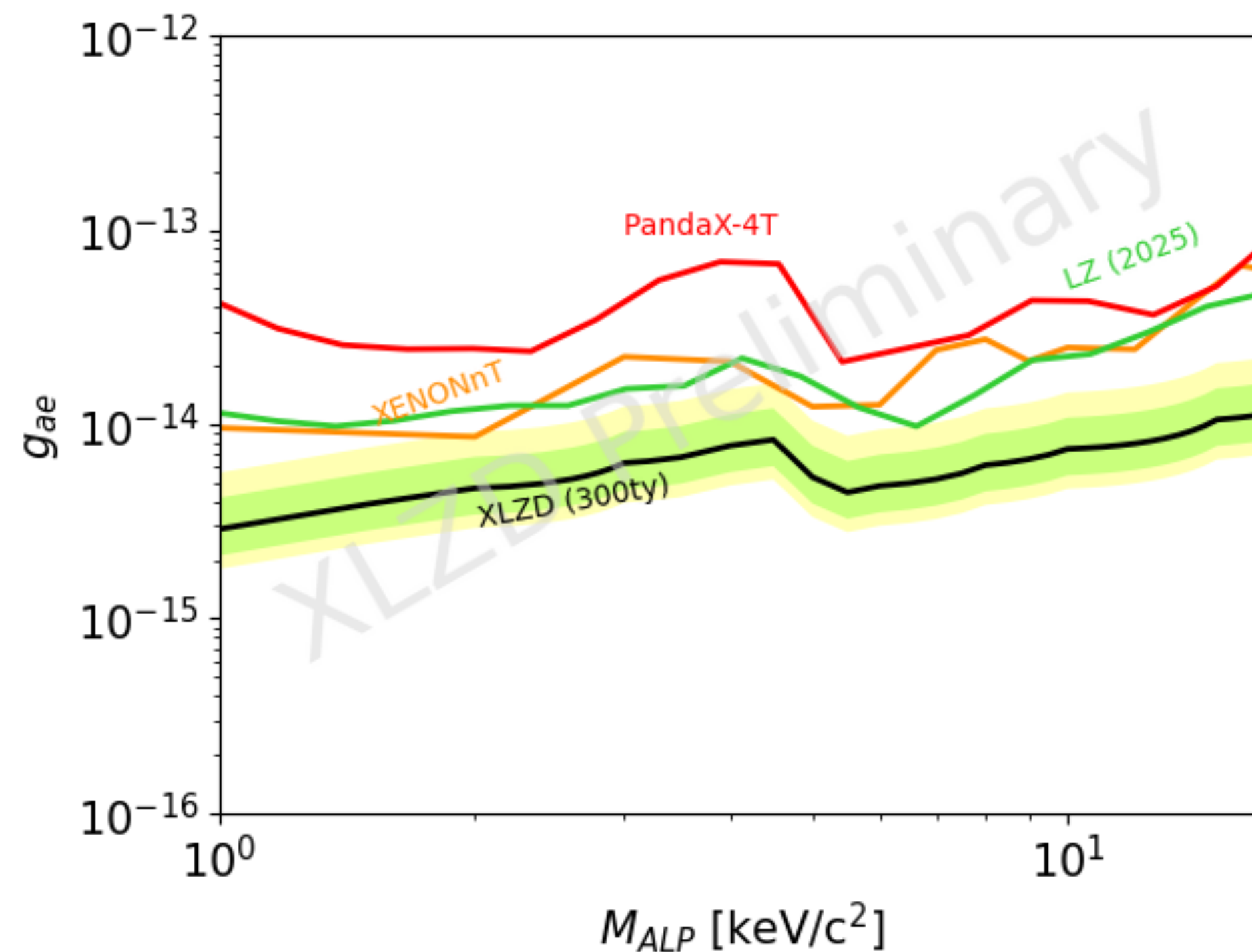

Waiting for Approval but has been allowed to present by XLZD

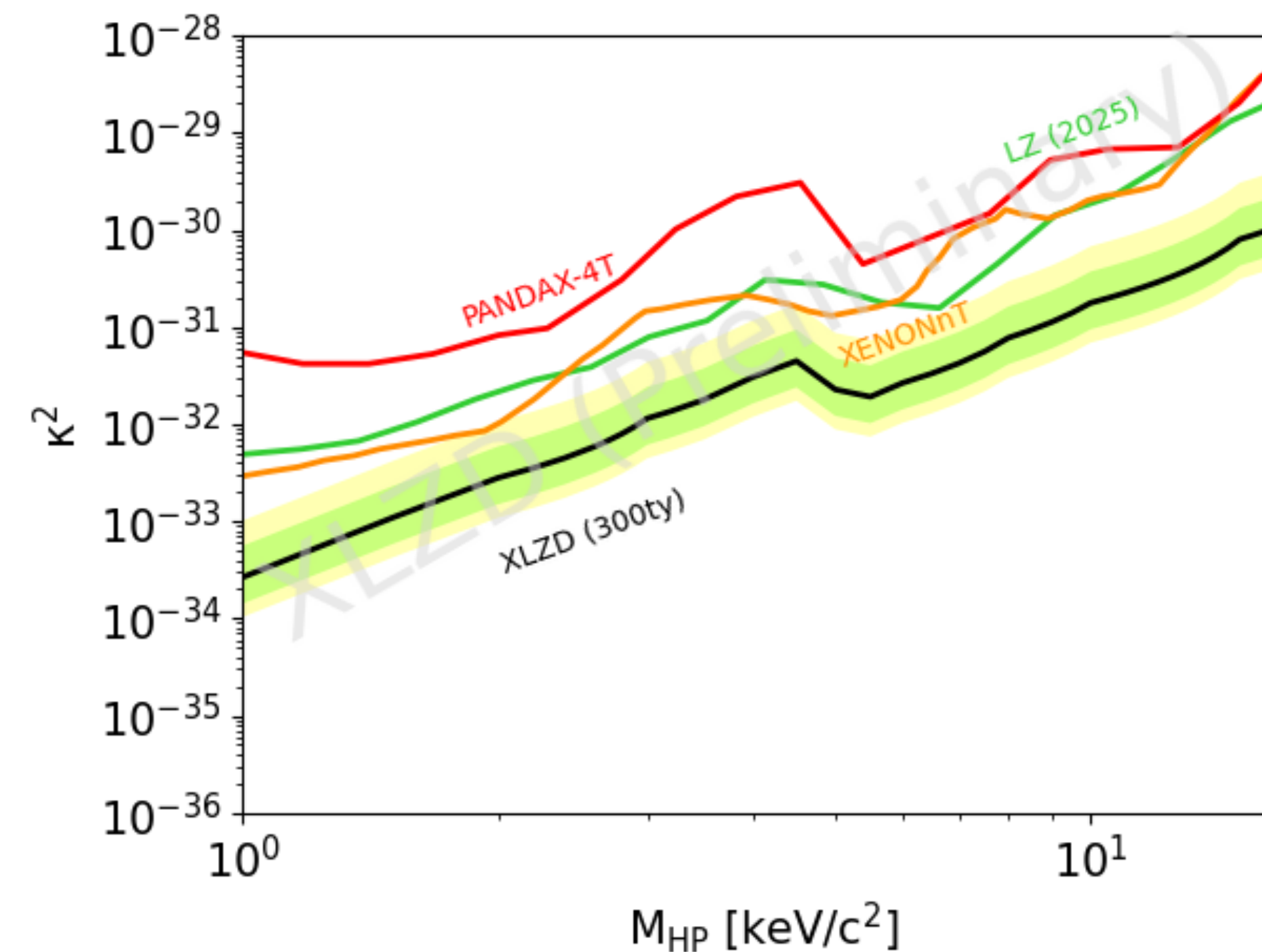

More information can be found:

*Pospelov, Maxim, Adam Ritz, and Mikhail Voloshin. Physical Review D—Particles, Fields, Gravitation, and Cosmology 78, no. 11 (2008): 115012.*

*Akerib, D. S., and LZ Collaboration. arXiv preprint arXiv:2511.17350.*

*E. Aprile et al. (XENON), Phys. Rev. Lett. 129, 161805 (2022), arXiv:2207.11330 [hep-ex].*

*X. Zeng et al. (PandaX), Phys. Rev. Lett. 134, 041001 (2025), arXiv:2408.07641 [hep-ex].*

# Mirror Dark Matter

- **Hidden sector is proposed to mirror standard model but with reversed space-time parity.**
- **Some mirrored particles in this hidden sector, because of broken symmetry, possibly could be dark matter**
- **Mirror dark matter could interact with standard model particles with kinetic mixing constant  $\epsilon$**

More information can be found:

*Foot, Robert. International Journal of Modern Physics A 29, no. 11n12 (2014): 1430013.*

# Sensitivity of Mirror Dark Matter $\epsilon$

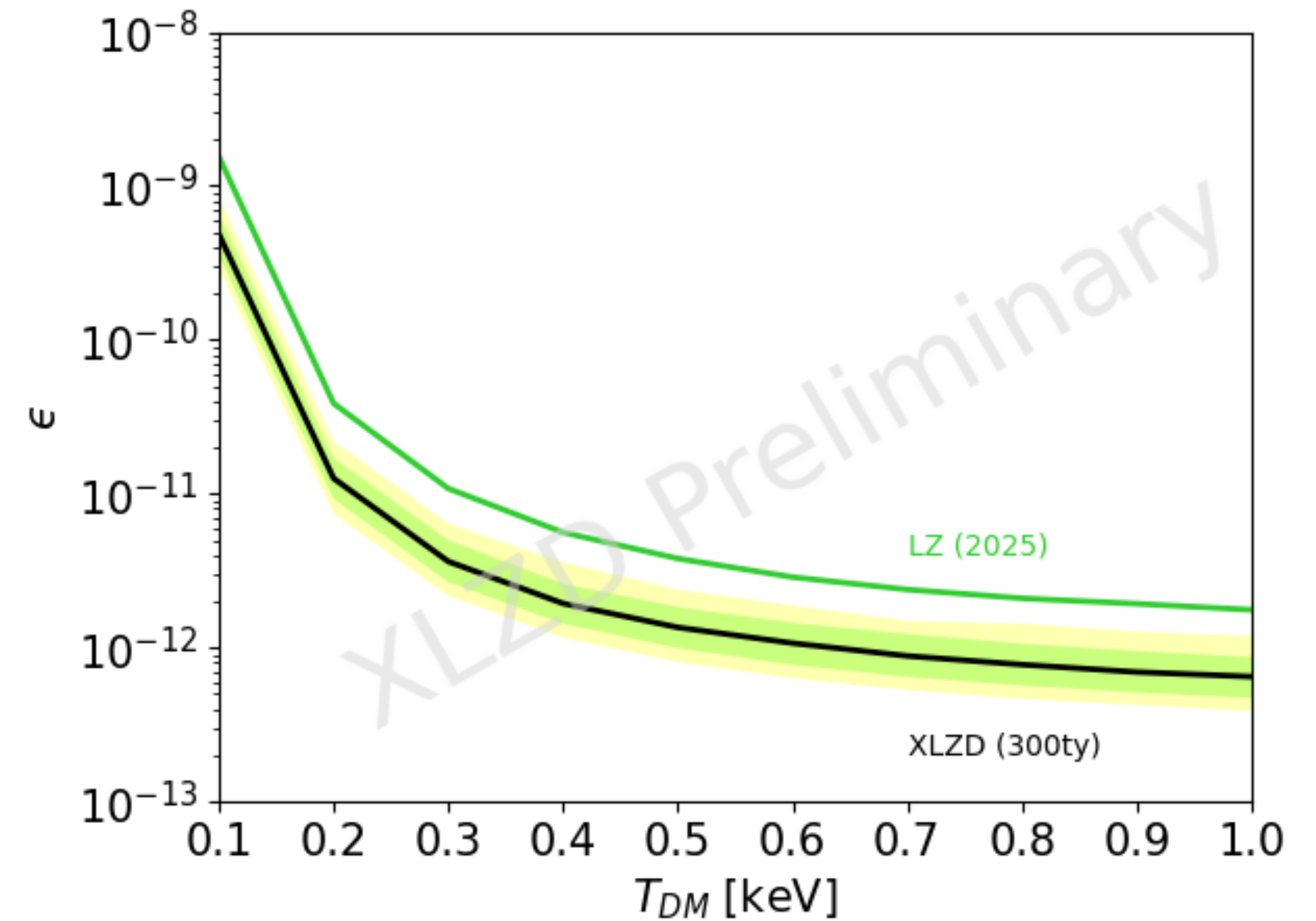
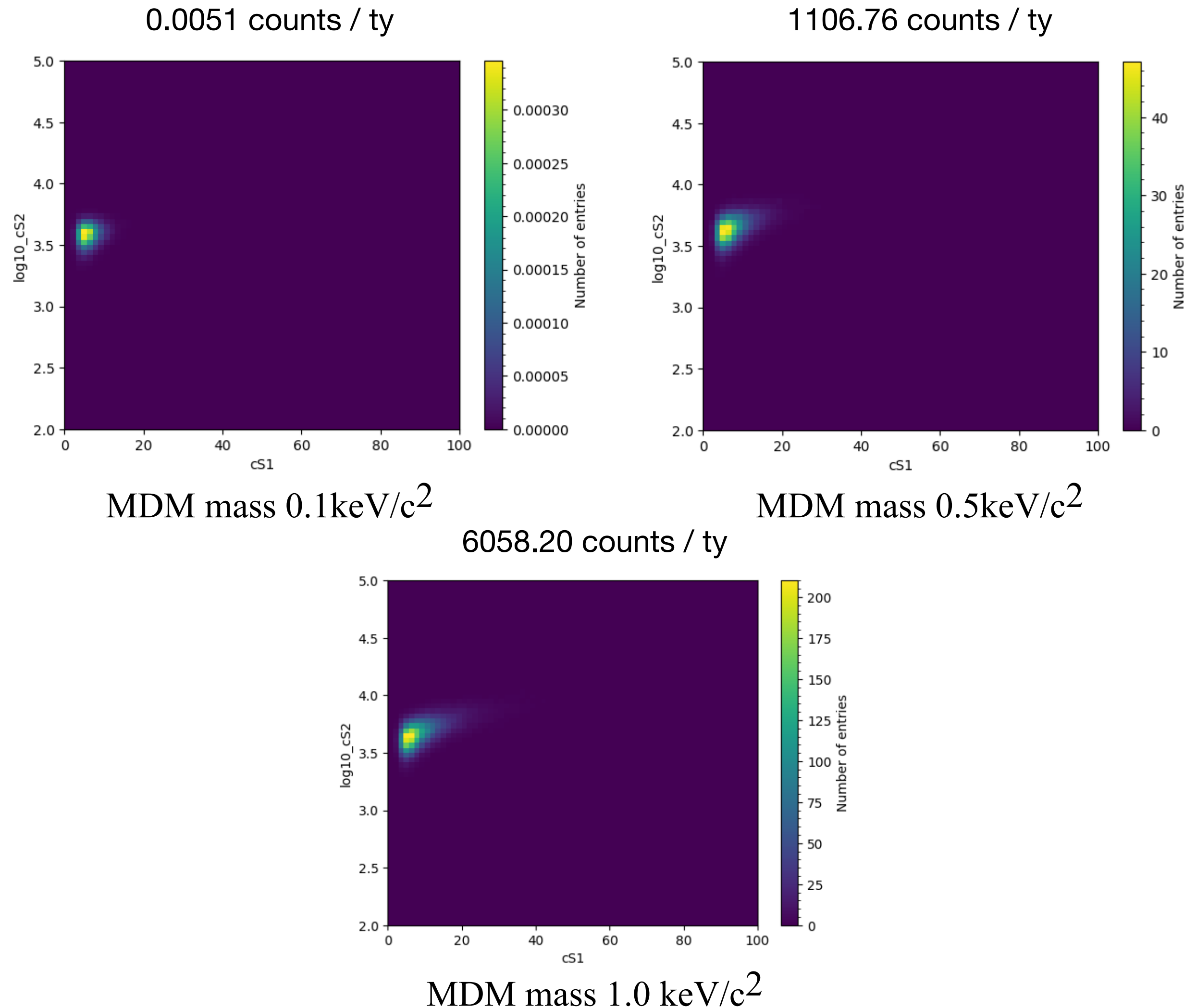

More information can be found:

*Foot, Robert. International Journal of Modern Physics A 29, no. 11n12 (2014): 1430013.*

*Akerib, D. S., and LZ Collaboration. arXiv preprint arXiv:2511.17350.*

# Conclusion

- Preliminary sensitivity projections have been produced for XLZD low-E-ER models with 300T-yr exposures.
- Expected improvement from XLZD [this work] is the factor of 3~4 better than the results of LZ preprint for following coupling constant:

Axion:  $g_{ae}^2$ ,  $g_{a\gamma}$ ,  $g_{ae}g_{aN}$ ,  $g_{a\gamma}g_{aN}$

ALP :  $g_{ae}$

HP :  $\kappa$

Solar Neutrino:  $\mu_\nu$  and  $\delta$

MDM:  $\epsilon$

- Future application will be in accidental coincidence and Migdal Signals from WIMP Recoils



**IOP**  
Institute of Physics



# Back-up

# XLZD Proposed Requirements of BKGs

Pb214 concentration @ 0.1 uBq / kg

Kr85 concentration @ 0.01 ppt or 0.03 ppt

More information can be found:

*Aalbers, Jelle, K. Abe, M. Adrover, S. Ahmed Maouloud, D. S. Akerib, A. K. Al Musalhi, F. Alder et al. The European Physical Journal C 85, no. 10 (2025): 1192*

# LZ 2023 Results

[Aalbers, J., D. S. Akerib, A. K. Al Musalhi, F. Alder, C. S. Amarasinghe, A. Ames, T. J. Anderson et al. *Physical Review D* 108, no. 7 (2023): 072006.]

