



# Particle Detector @CERN

Dr. Chayanit Asawatangtrakuldee

Department of Physics Chulalongkorn University

# CERN

## Conseil Européen pour la Recherche Nucléaire (1954)

- At the end of the Second World War, European science was no longer world-class
- A handful of visionary scientists imagined creating a European atomic physics laboratory
- At an intergovernmental meeting of UNESCO in Paris in December 1951, the first resolution concerning the establishment of a **European Council for Nuclear Research** was adopted. Two months later, 11 countries signed an agreement establishing the provisional council – the acronym CERN was born
- Geneva was selected as the site for the CERN



# CERN

## Conseil Européen pour la Recherche Nucléaire (1954)

### Member States of CERN

Member States (date of accession)

 Austria (1959)	 Sweden (1953)	
 Belgium (1953)	 Switzerland (1953)	
 Bulgaria (1999)	 United Kingdom (1953)	
 Czech Republic (1993)	<b>States in accession to Membership and Associate Members</b>	
 Denmark (1953)	 Croatia (2019)	
 Finland (1991)	 Cyprus (2016)	
 France (1953)	 India (2017)	
 Germany (1953)	 Lithuania (2018)	
 Greece (1953)	 Pakistan (2015)	
 Hungary (1992)	 Slovenia (2017)	
 Israel (2014)	 Turkey (2015)	
 Italy (1953)	 Ukraine (2016)	
 Netherlands (1953)		
 Norway (1953)		
 Poland (1991)		
 Portugal (1986)		
 Romania (2016)		
 Serbia (2019)		
 Slovakia (1993)		
 Spain (1961-1968, 1983-)		



<https://cds.cern.ch/record/2714659>

- Today 25 member states
  - 11 associated member states
- (<https://home.cern/about/who-we-are/our-governance/member-states>)
- **Thailand** has an International Cooperation Agreement with CERN since 2018

# CERN Missions



# CERN and WWW

- Tim Berners-Lee, a British scientist, invented the World Wide Web (WWW) in 1989, while working at CERN. The web was originally conceived and developed to meet the demand for automated information sharing between scientists in universities and institutes around the world.
- On 30 April 1993, CERN put the World Wide Web software in the public domain.



# CERN Experiments

## LHC experiments

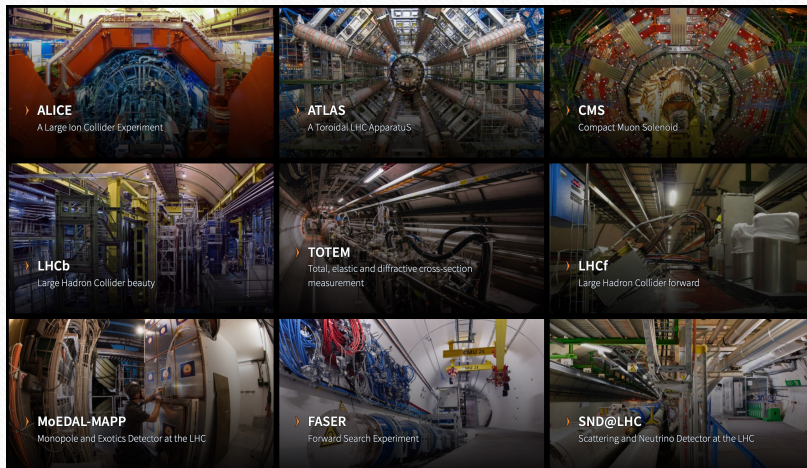

## Non-accelerator experiments



## Antimatter experiments

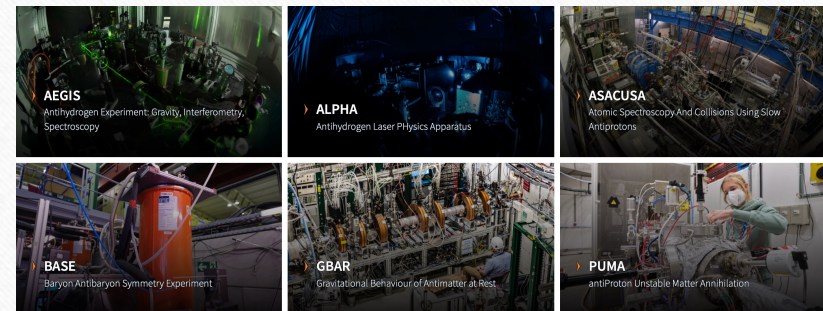

## Fixed-target experiments

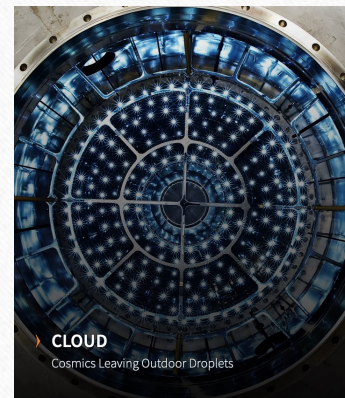

# Large Hadron Collider (LHC)

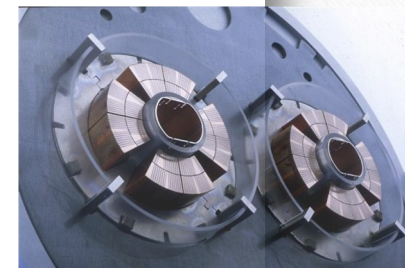
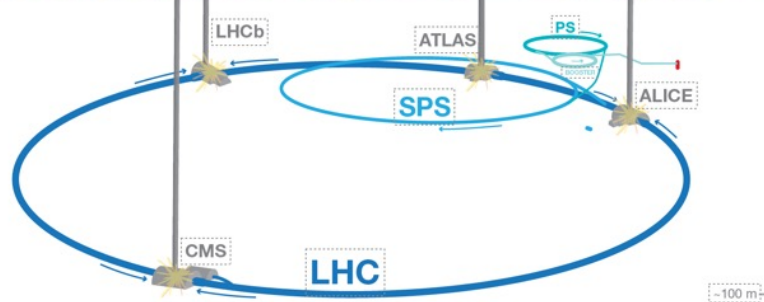
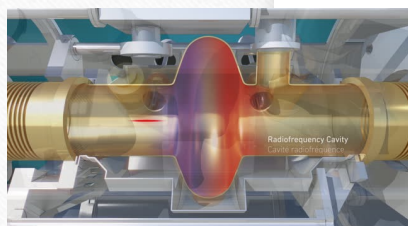
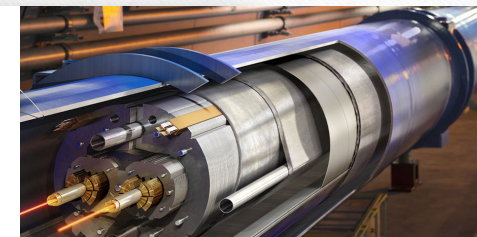
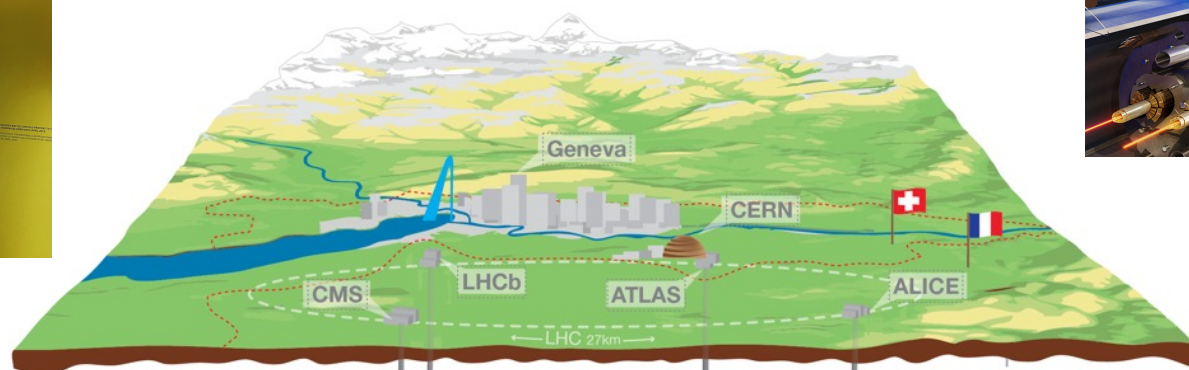

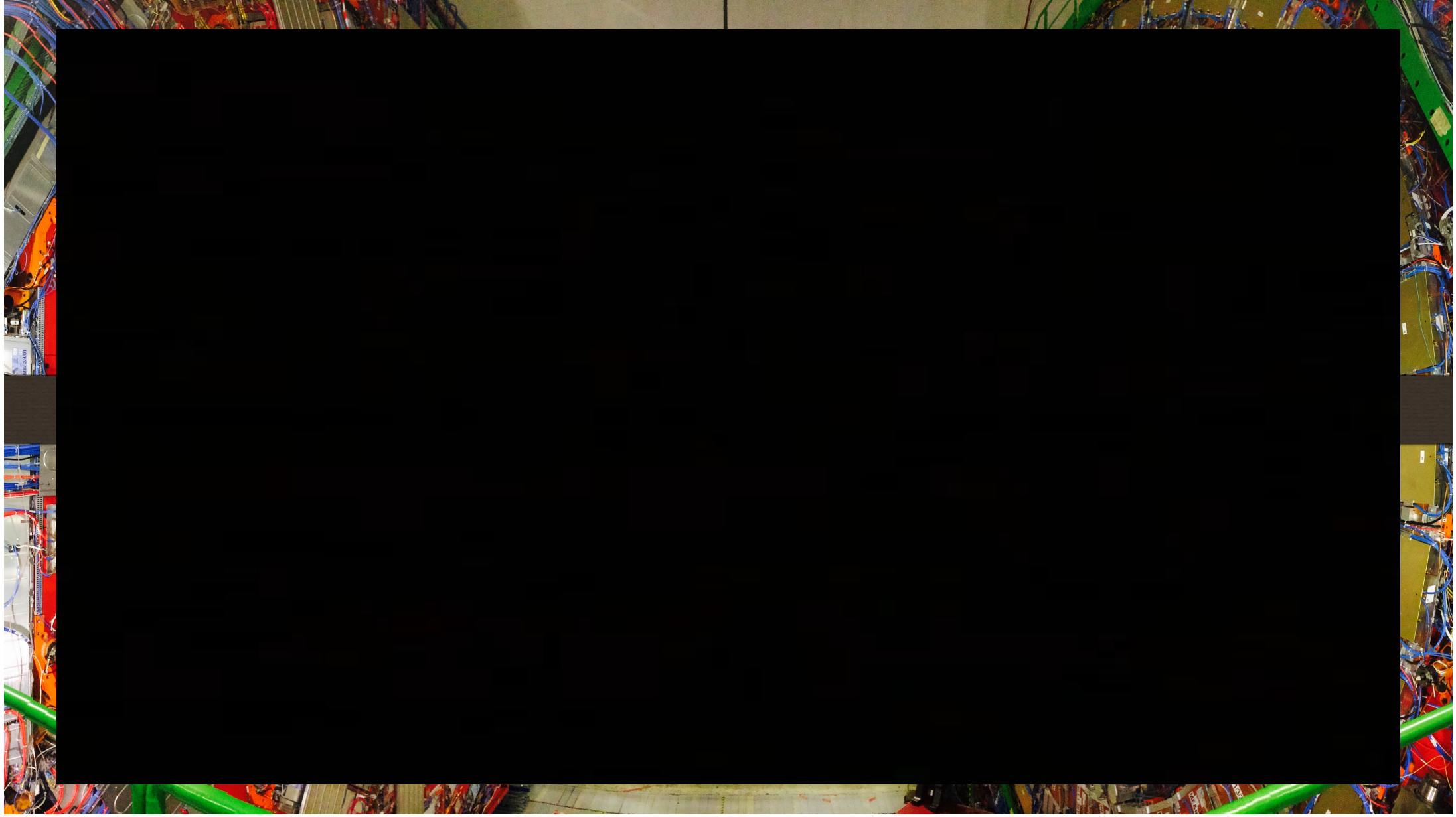

# How a Detector works

“Just as hunters can identify animals from tracks in mud or snow, physicists identify subatomic particles from the traces they leave in detectors” -- *CERN*



# Detectors @CERN

- **Tracking devices**
  - reveal the paths of charged particles as they pass through and interact with suitable substances
  - record tiny electrical signals that particles trigger and reconstructed the patterns of tracks by a computer program.
- **Calorimeters**
  - measures the energy a particle loses as it passes through
  - perform two different tasks -- stopping particles and measuring energy loss
- **Particle-identification detectors**
  - by measuring a particle's velocity and combine with momentum measured in the tracking devices, helps to calculate a particle's mass and therefore its identity.

# A Chronology

## Instrumentation

## Particle Physics

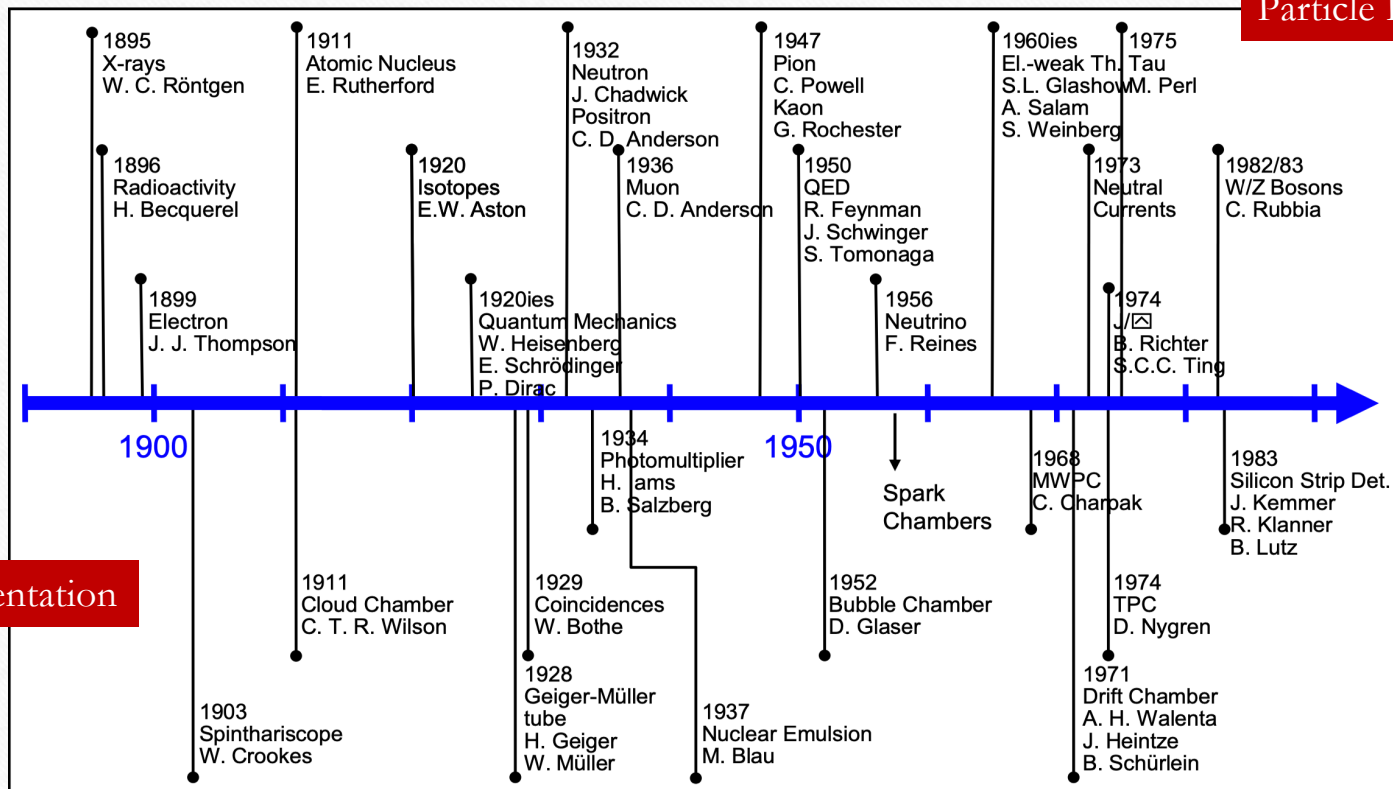

# A Chronology

## Instrumentation

## Particle Physics

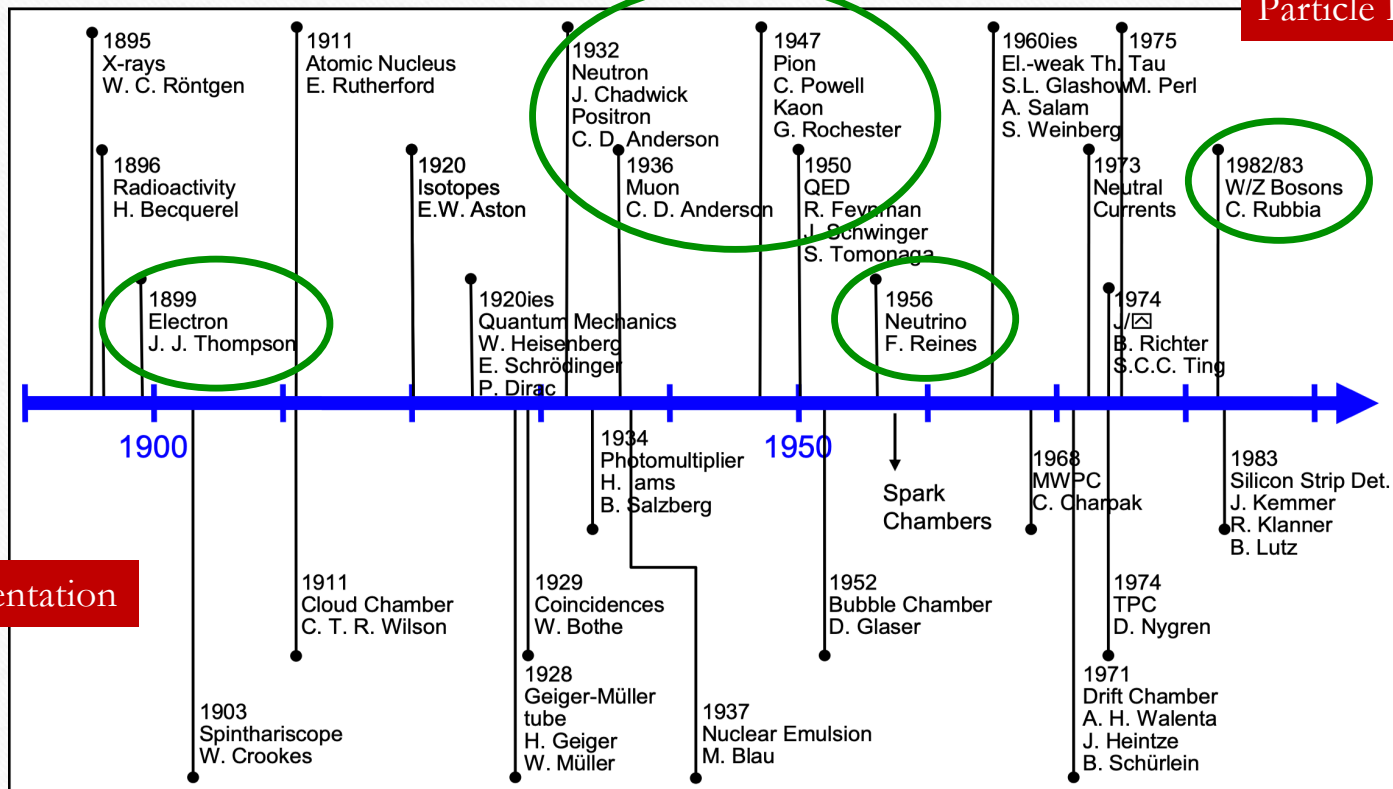

# A Chronology

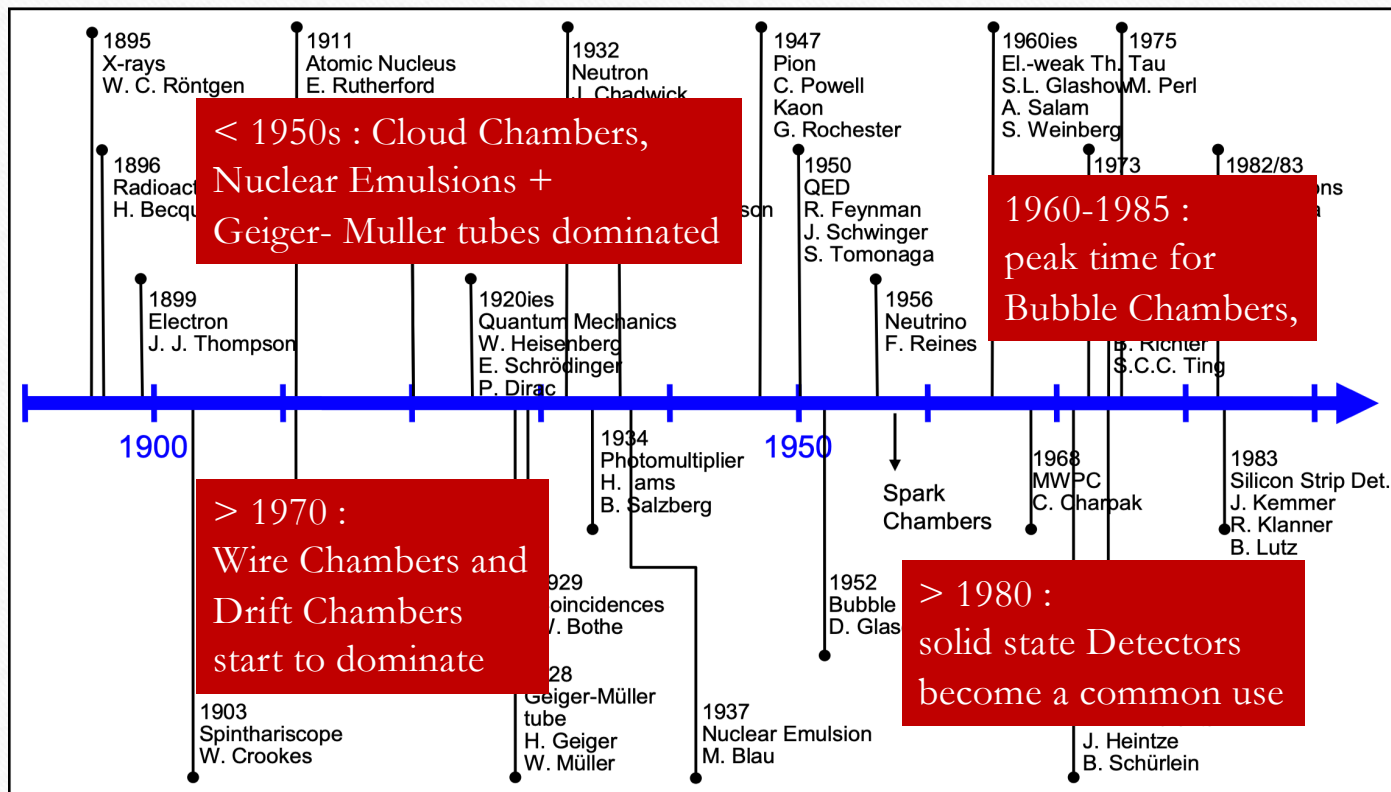

# Spintharoscope (1903)

- Invented and beautifully named by **William Crookes** in 1903, is a device for seeing individual atoms or at least, seeing the death of individual atoms

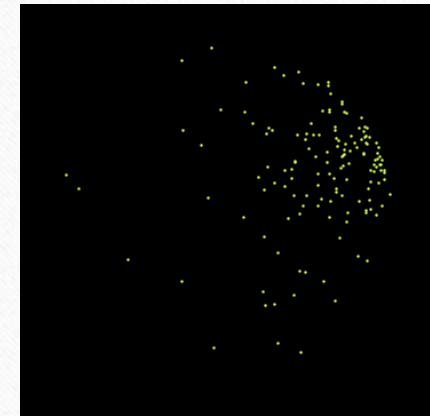

- Consist of a small screen coated with **zinc sulfide** affixed to the end of a tube, with a tiny amount of **radium salt** suspended a short distance from the screen and a lens on the other end of the tube for viewing the screen. Crookes named his device after the Greek word 'spintharis', meaning "**a spark**"

# Cloud Chamber (1911)

- Originally developed to study formation of rain clouds
- Passage of charged particle would condense the vapor into tiny droplets, making the particle's path → their number being proportional to  $dE/dx$
- The discoveries of positron in 1932 and muon in 1936, both by Carl Anderson (awarded a Nobel Prize in Physics in 1936), used cloud chambers

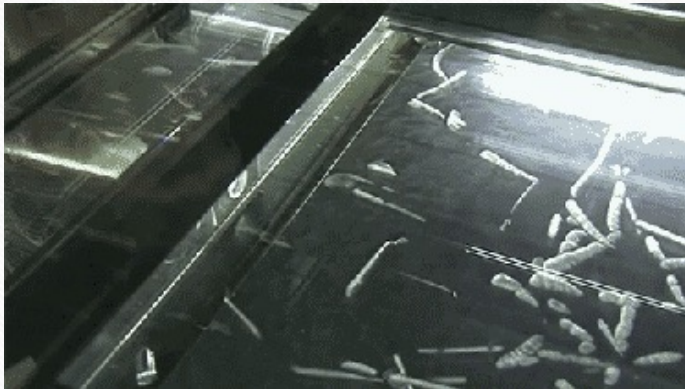

**Charles Thomson Rees Wilson**  
(1869–1959)  
**Nobel Prize in 1927**



# Geiger-Müller Tube (1928)

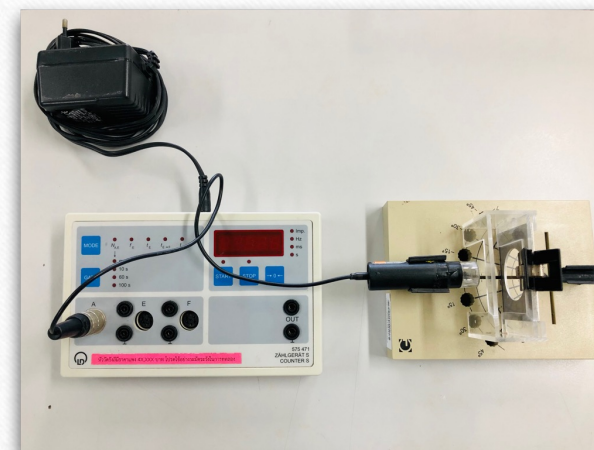
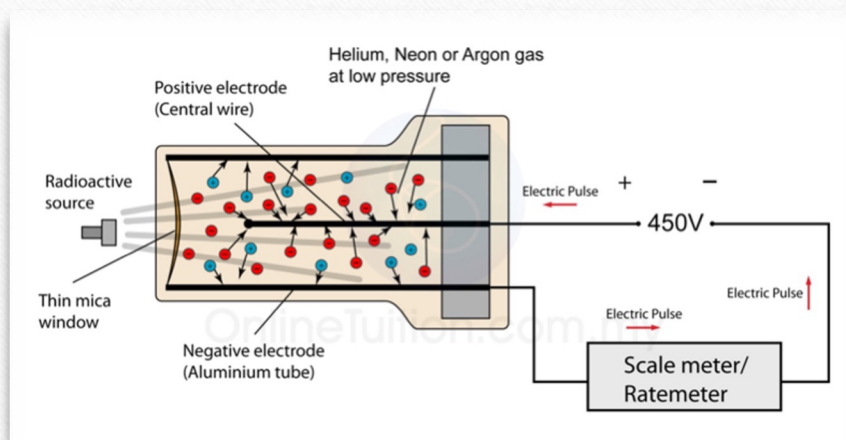

- The Geiger-Müller tube (1928 by Hans Geiger and Walther Müller)
  - Tube filled with inert gas (He, Ne, Ar) + organic vapor (alcohol)
  - Avalanche process : exponential increase of electrons (and ions)

# Bubble Chamber (1952)

Credit : [https://en.wikipedia.org/wiki/Bubble\\_chamber](https://en.wikipedia.org/wiki/Bubble_chamber)

- Instead of supersaturating a gas with a vapor one would superheat the liquid
- A particle leave a trail of ions along its path → make a liquid boil and form gas bubbles around ions



Donald A. Glaser  
Nobel Prize in 1960



Big European Bubble Chamber  
(BEBC) 1973-1984

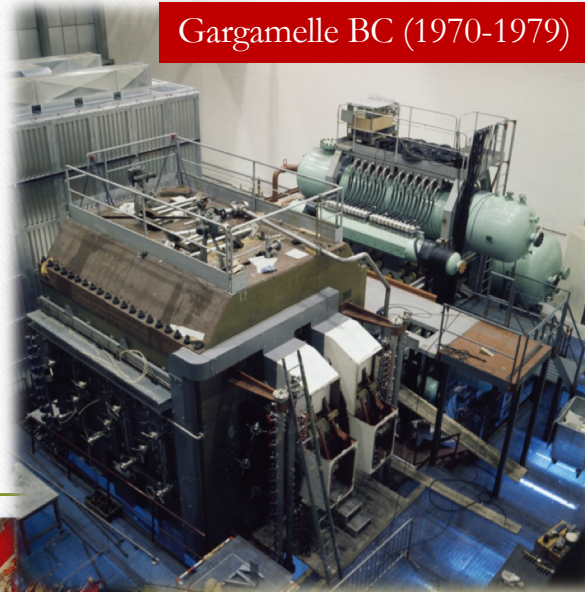

Gargamelle BC (1970-1979)

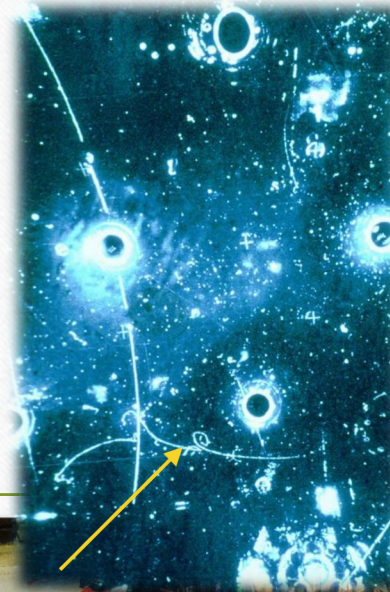

# MWP Chambers (1968)

Credit : <https://home.cern/news/news/experiments/fifty-years-charpak-revolutionised-particle-detectors>

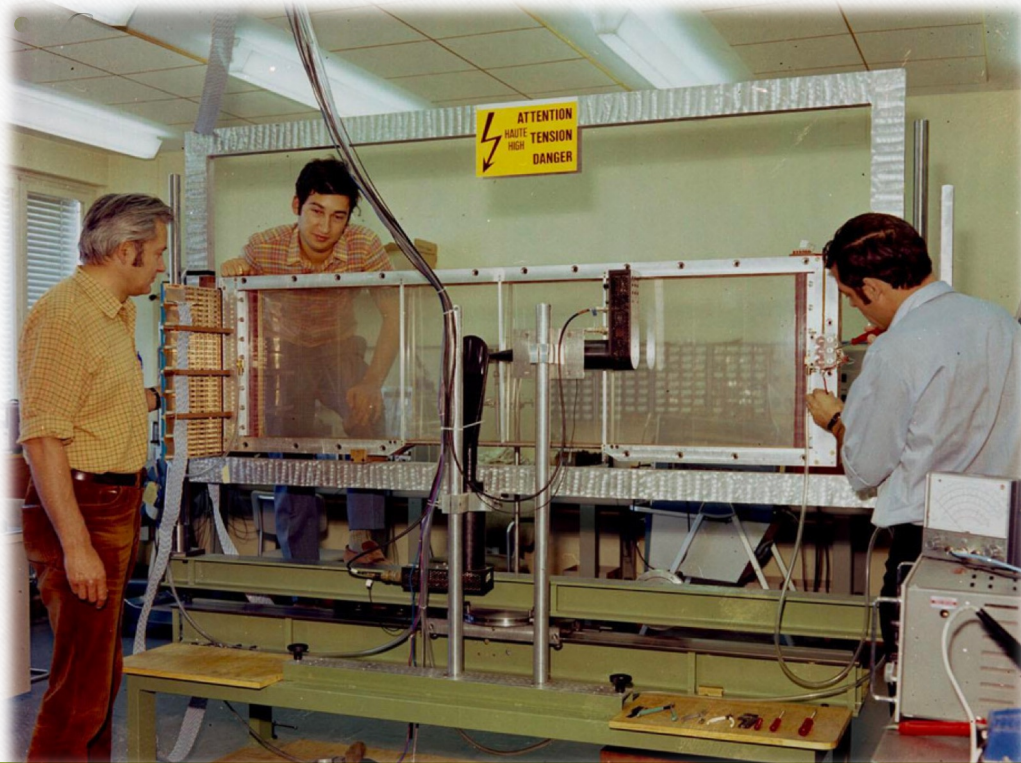

- Multi Wire Proportional Chambers (MWPC)

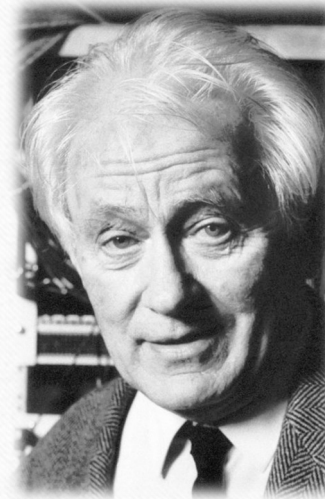

Georges Charpak  
(1924–2010)  
Nobel Prize in 1992

# Some more...

**Photomultiplier tube**  
Harley Iams & Bernard Salzberg (1934)

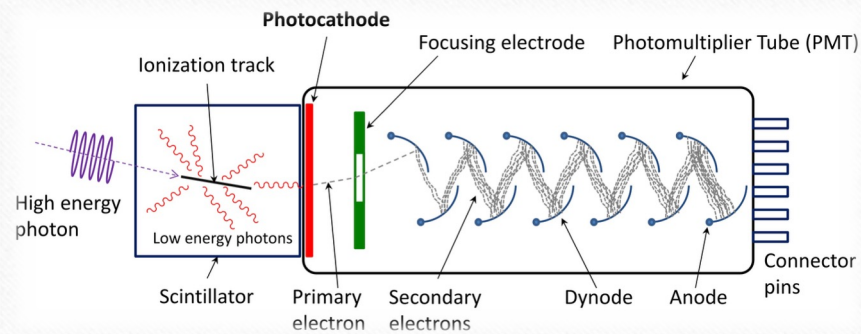
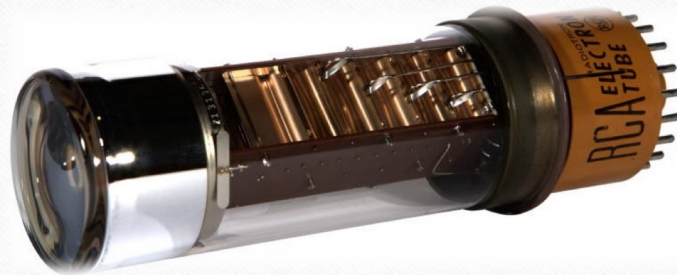

**Nuclear Emulsions**  
Marietta Blau (1937)

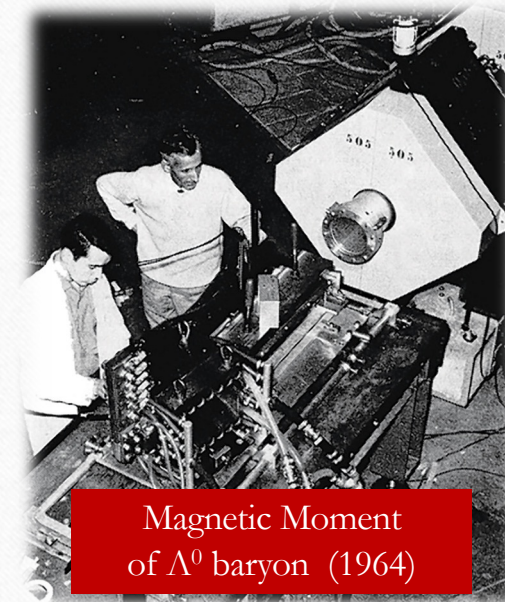

Credit : <https://cerncourier.com/a/nuclear-emulsions/> 19

# LHC Detectors

ATLAS

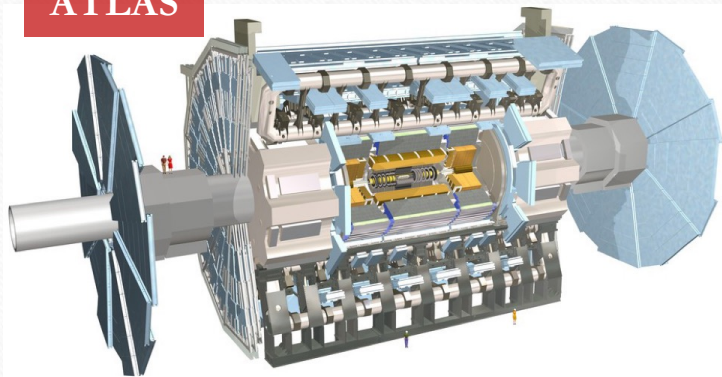

CMS

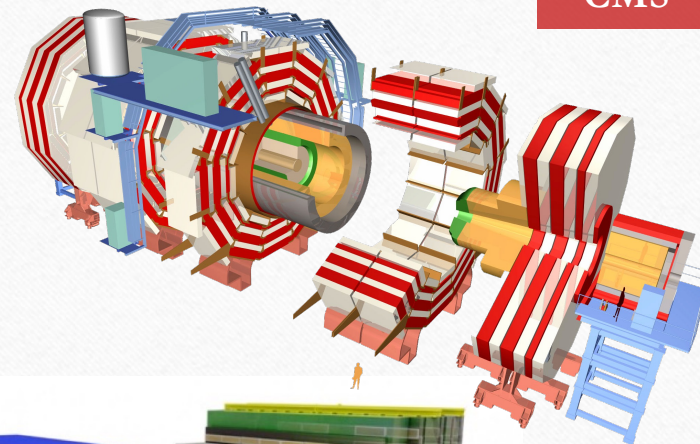

ALICE

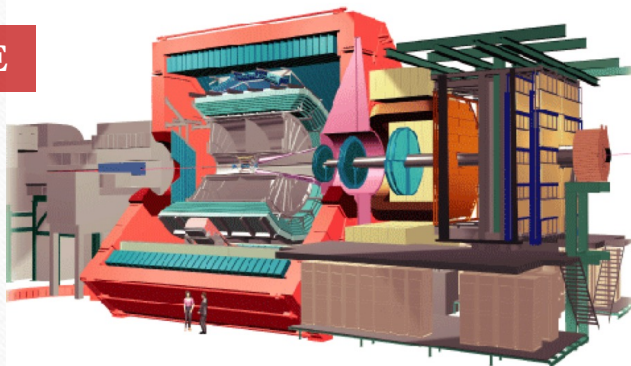

LHCb

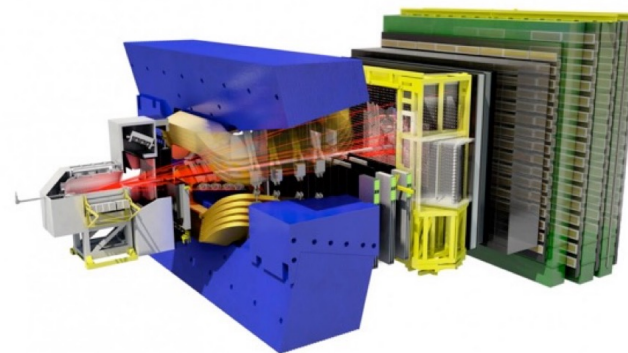

# Detectors @CERN

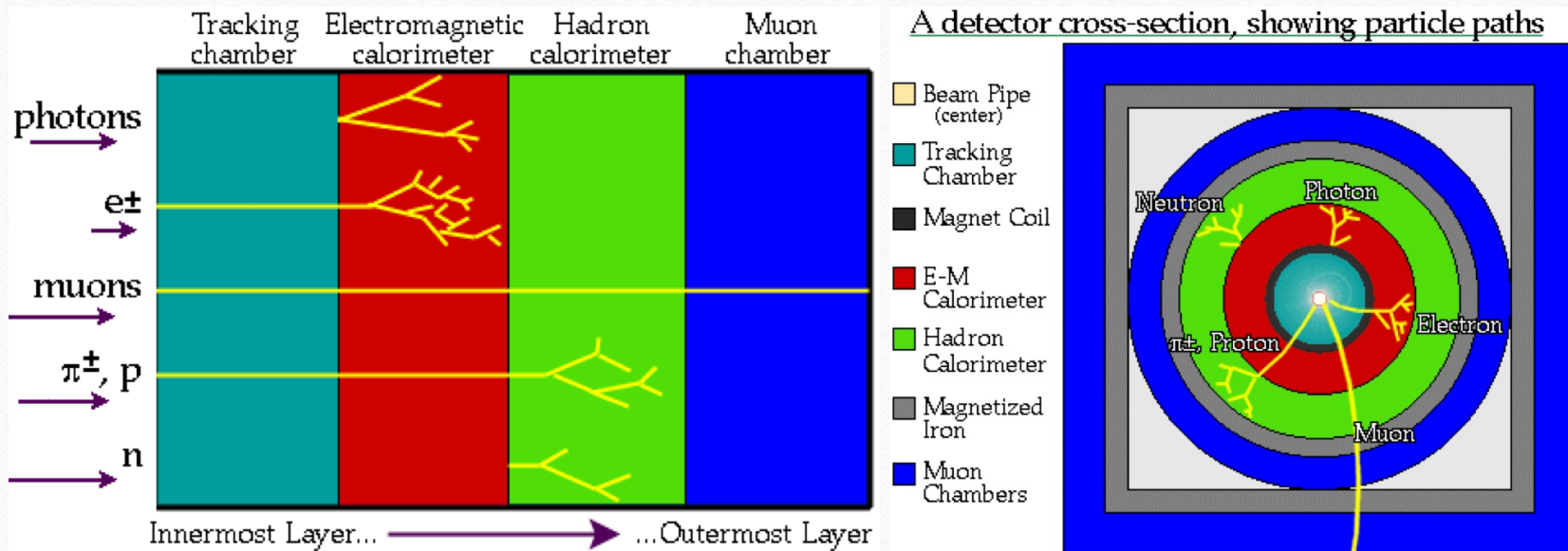

- Not all particles are detected, some leave the detector without any trace (neutrinos), some escape through not sensitive detector areas (holes, cracks for e.g., water cooling and gas pipes, cables, electronics, mechanics)

# Compact Muon Solenoid (CMS)

## CMS DETECTOR

Total weight : 14,000 tonnes  
 Overall diameter : 15.0 m  
 Overall length : 28.7 m  
 Magnetic field : 3.8 T

STEEL RETURN YOKE  
 12,500 tonnes

### SILICON TRACKERS

Pipel (100x150  $\mu\text{m}$ )  $\sim 16\text{m}^2 \sim 66\text{M}$  channels  
 Microstrips (80x180  $\mu\text{m}$ )  $\sim 200\text{m}^2 \sim 9.6\text{M}$  channels

### SUPERCONDUCTING SOLENOID

Niobium titanium coil carrying  $\sim 18,000\text{A}$

### MUON CHAMBERS

Barrel: 250 Drift Tube, 480 Resistive Plate Chambers  
 Endcaps: 468 Cathode Strip, 432 Resistive Plate Chambers

### PRESHOWER

Silicon strips  $\sim 16\text{m}^2 \sim 137,000$  channels

### FORWARD CALORIMETER

Steel + Quartz fibres  $\sim 2,000$  channels

### CRYSTAL ELECTROMAGNETIC CALORIMETER (ECAL)

$\sim 76,000$  scintillating PbWO<sub>4</sub> crystals

### HADRON CALORIMETER (HCAL)

Brass + Plastic scintillator  $\sim 7,000$  channels

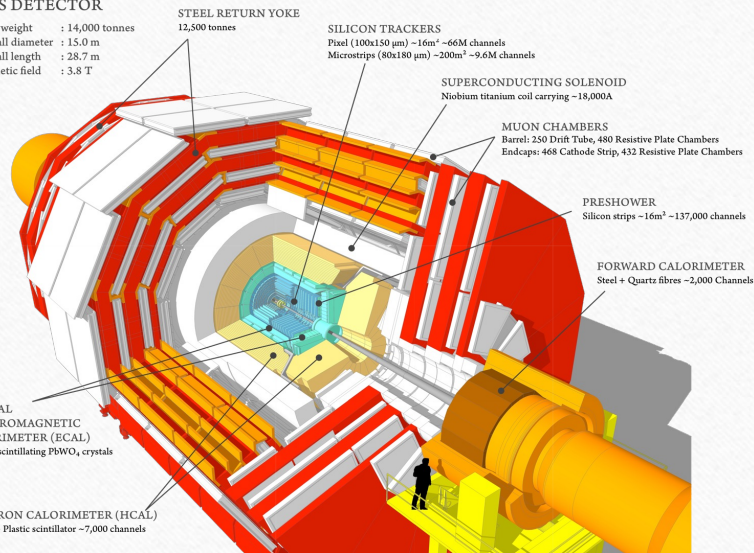

Key:

- Muon
- Electron
- Charged Hadron (e.g. Pion)
- - - Neutral Hadron (e.g. Neutron)
- - - Photon

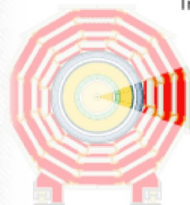
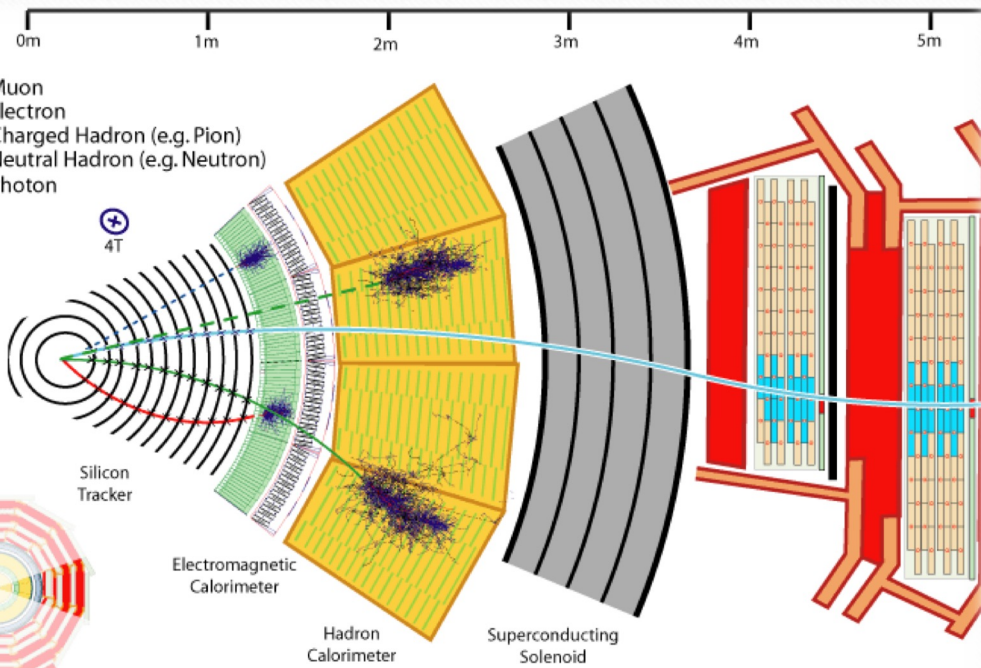

Transverse slice through CMS

Iron return yoke interspersed with Muon chambers

# Tracker

Credit : <https://cms.cern/detector/identifying-tracks>

- Records the paths taken by charged particles by measuring their positions at number of key points
- 4 inner layers of Pixel detector (Phase I)
- 10 outer layers of Silicon Strips detector

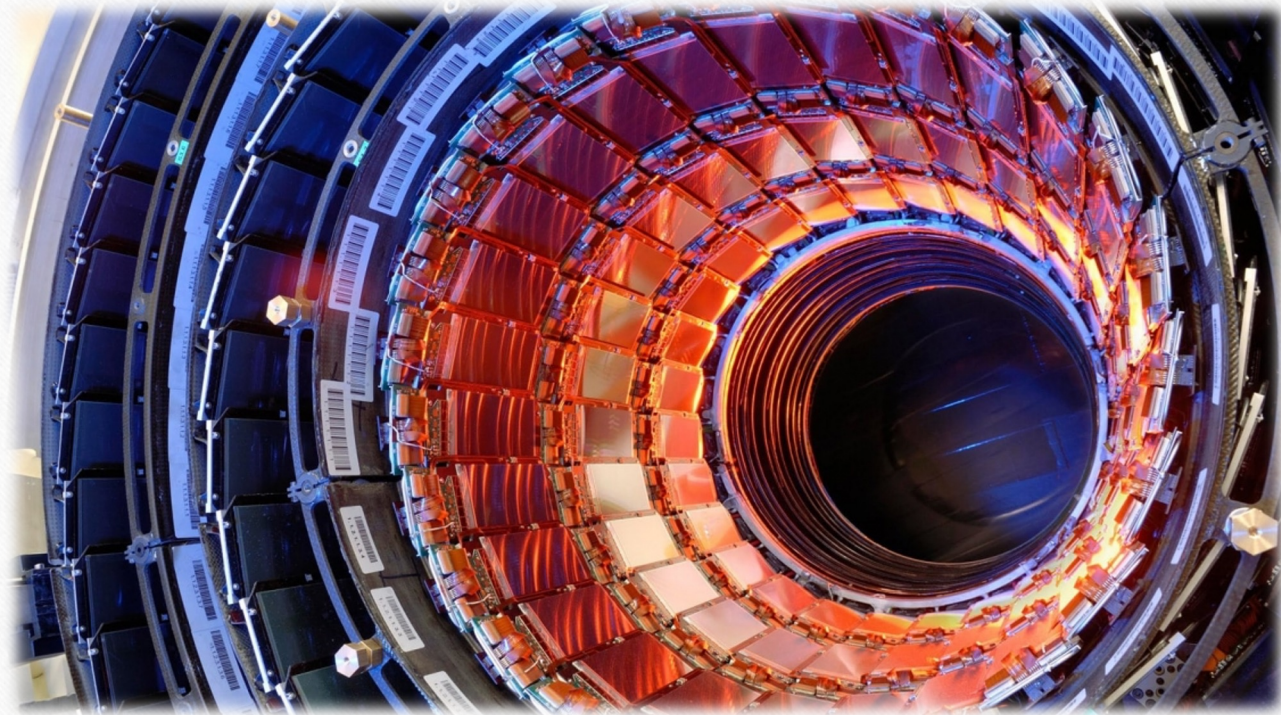

# Electromagnetic Calorimeter (ECAL)

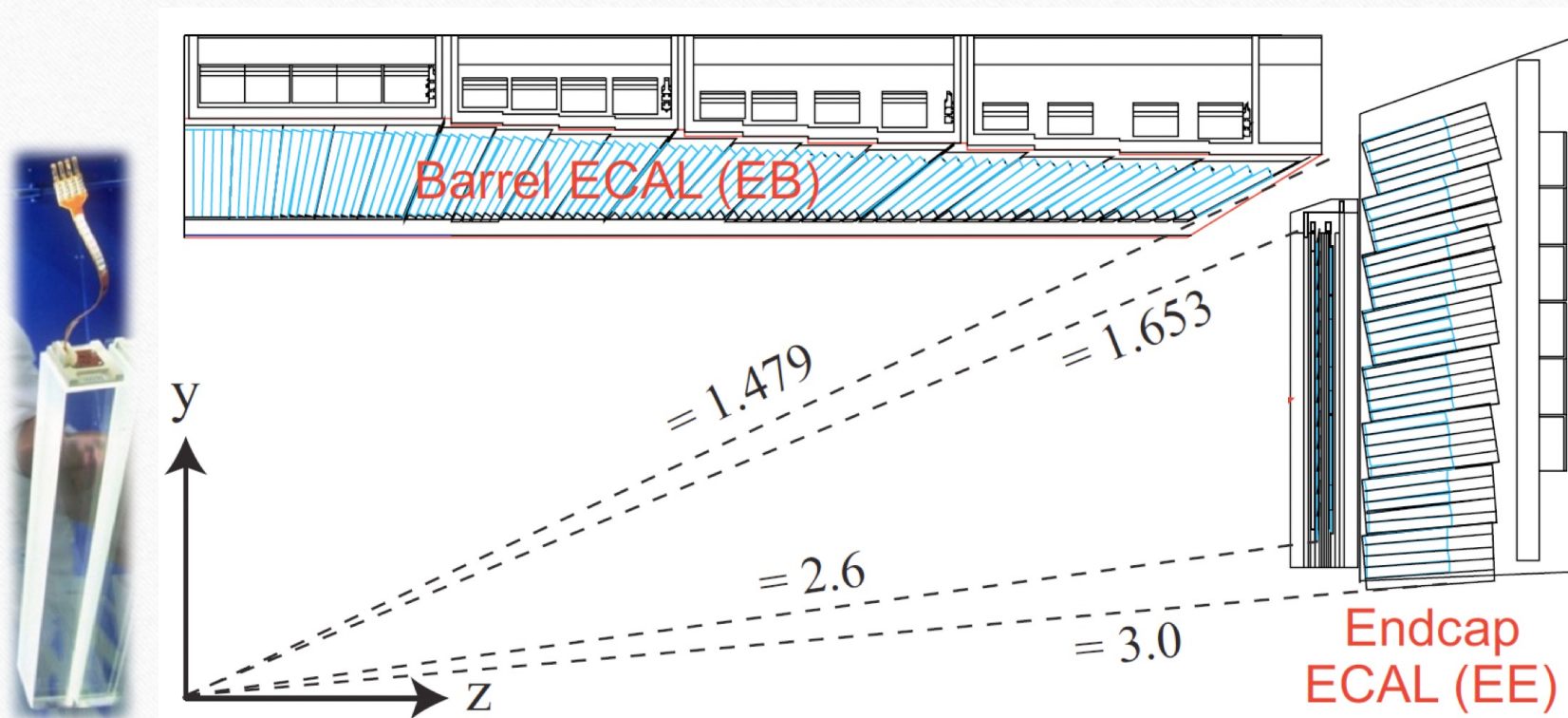

# Hadronic Calorimeter (HCAL)

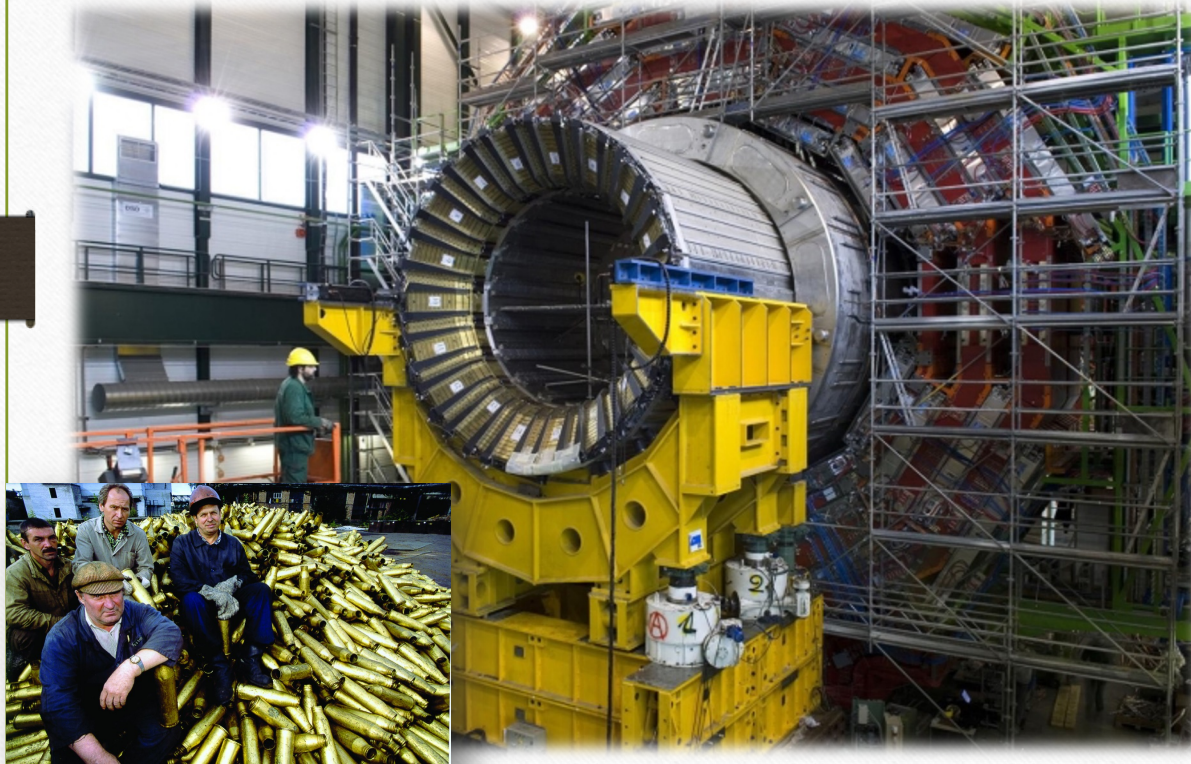

- HCAL measures the energy of hadrons, particles made of quarks and gluons
- A sampling calorimeter (material that produces the particle shower is distinct from the material that measures the deposited energy)
- Alternating layers of **absorber** and fluorescent **scintillator** materials that produce a rapid light pulse when the particle passes through

# Solenoid Magnet (4 T)

- Charged particles are deflected by magnetic field

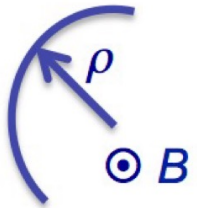

$$\rho = \frac{p_T}{q|B|} = \frac{\gamma m_0 \beta c}{q|B|}$$

- By measuring the radius of curvature, we can determine the momentum of a particle
- If we can measure also  $\beta$  (velocity) independently we can determine the particle mass and identify it



# Muon Chamber

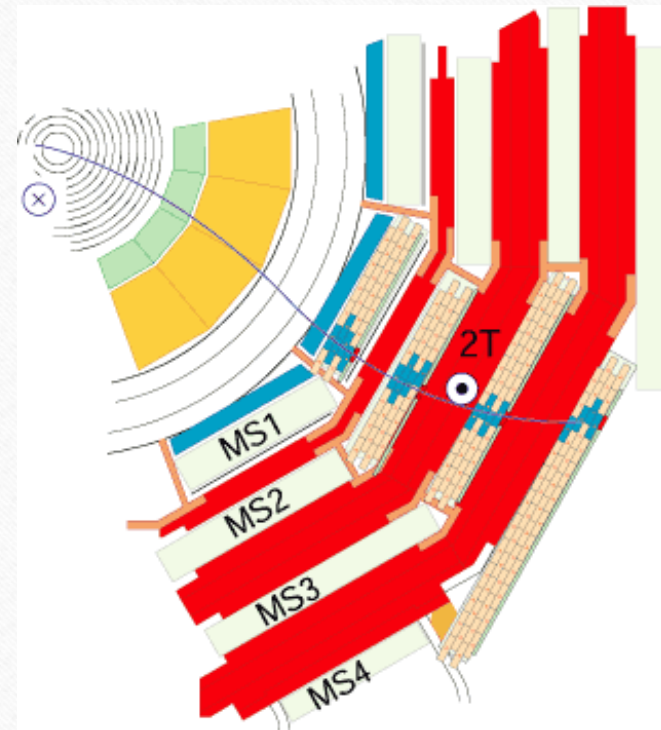
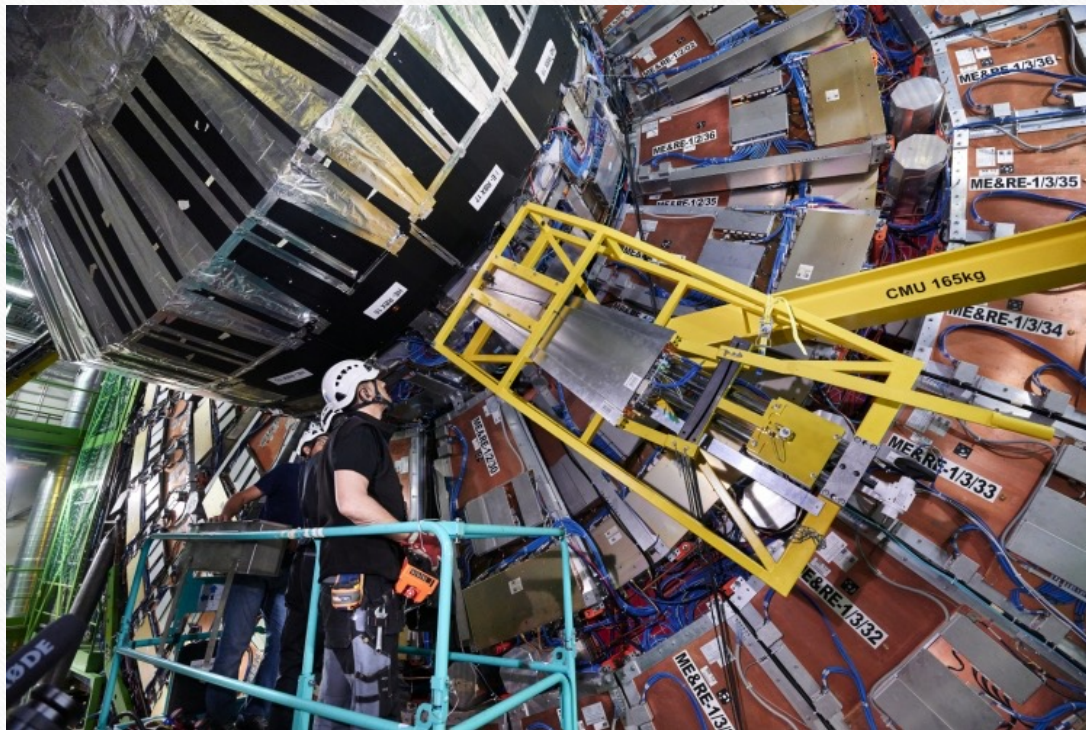

# Any undetected particles?

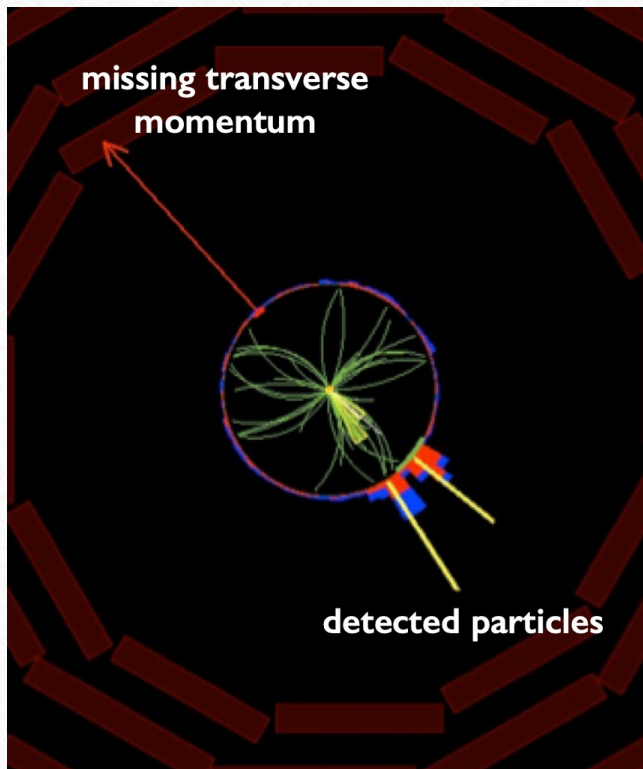

- Onion-like shape detector to avoid missing particles but still...
- In collider experiment, we detect this kind of particle indirectly from the momentum imbalance in the plane perpendicular to the beam direction. This quantity known as missing transverse momentum
- What we do is summing up all visible energy and momentum, then attribute missing energy and momentum to neutrino or undetected particles

# Every 25 ns

- 40M events per sec
  - 2 MB/events
  - 80 TB/sec
- **Impossible** for storage and CPU to process all events
- We need pre-selection based on physics of interest
  - **“Trigger system”**

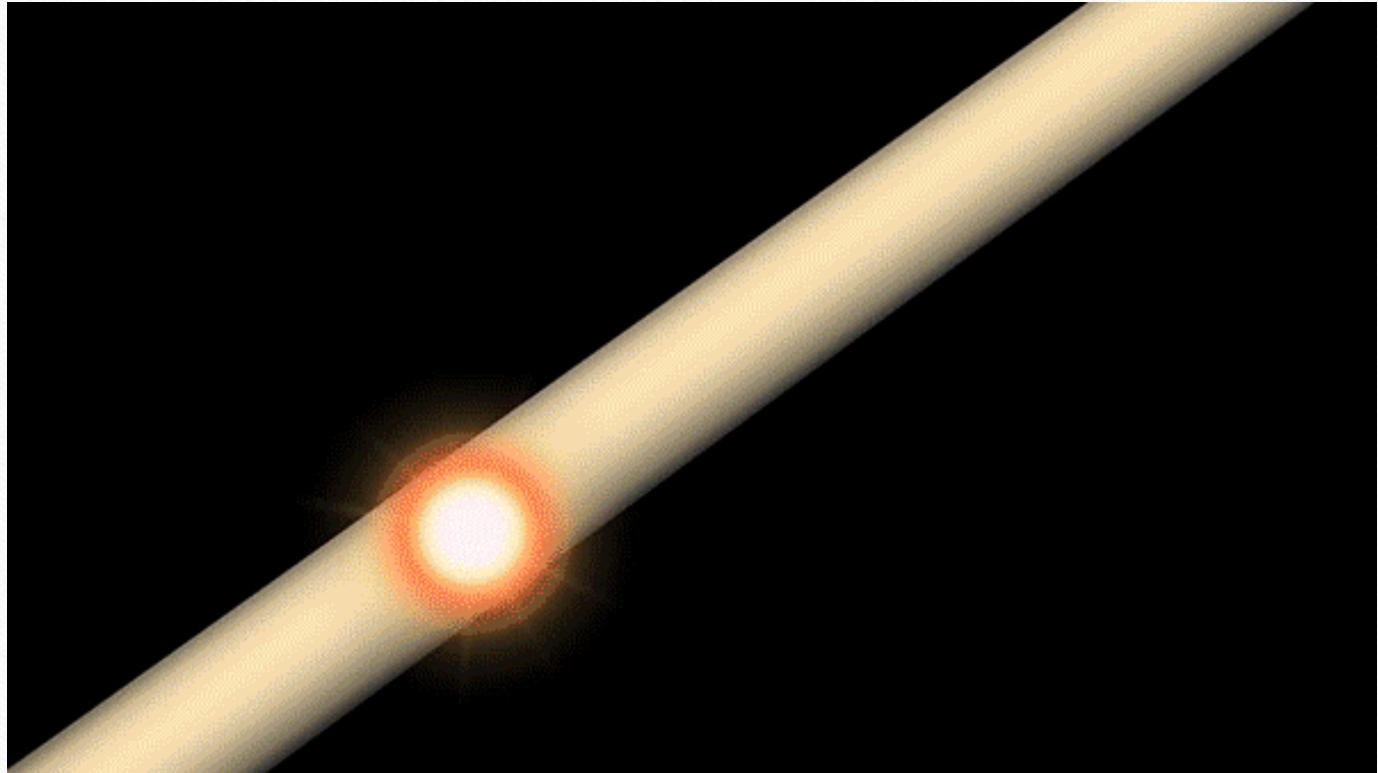

# Dealing with Big Data

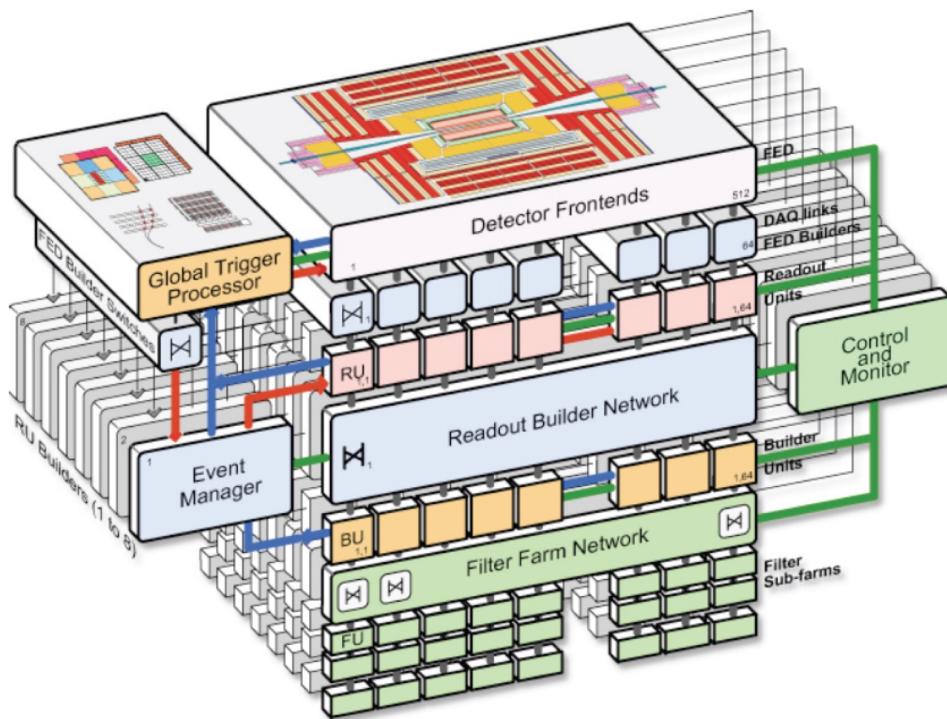

## Trigger Rate

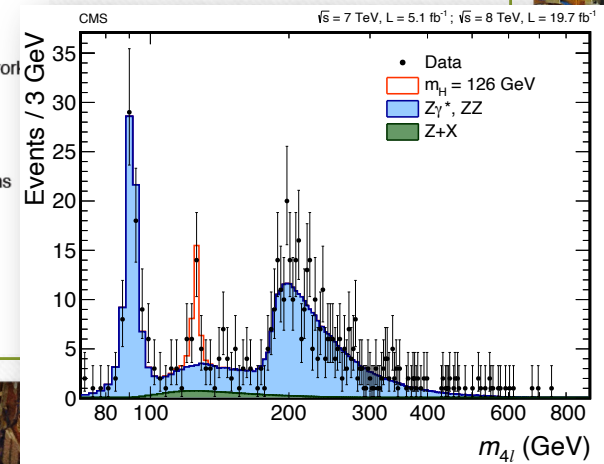
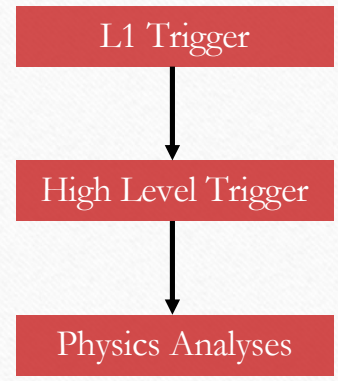
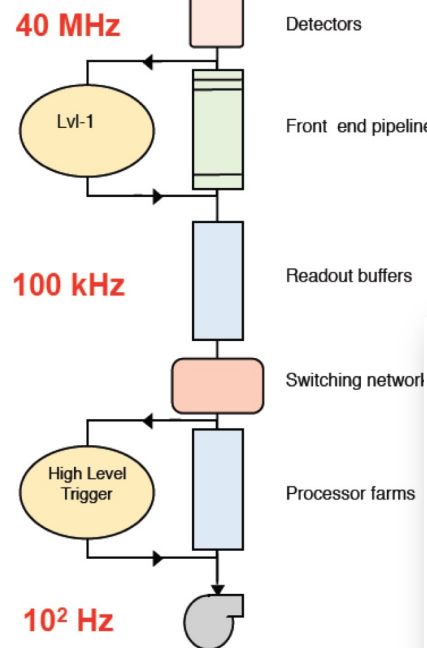

# Neutrino Detectors at LHC

## Scattering and Neutrino Detector at LHC



The SND@LHC is located underground close to the ATLAS experiment, in an unused tunnel that links the LHC to the Super Proton Synchrotron

- A hybrid detector optimized for the identification of three neutrino flavors and for the detection of feebly interacting particles

# Neutrino Detectors at LHC

- **VETO SYSTEM:**
  - tag penetrating muons
- **VERTEX DETECTOR + EM CAL:**
  - Emulsion cloud chambers (Emulsion + Tungsten) for neutrino interaction detection
  - Scintillating fibers for timing information and energy measurement
- **HAD CAL + MUON SYSTEM:**
  - iron walls interleaved with plastic scintillator planes for fast time resolution and energy measurement

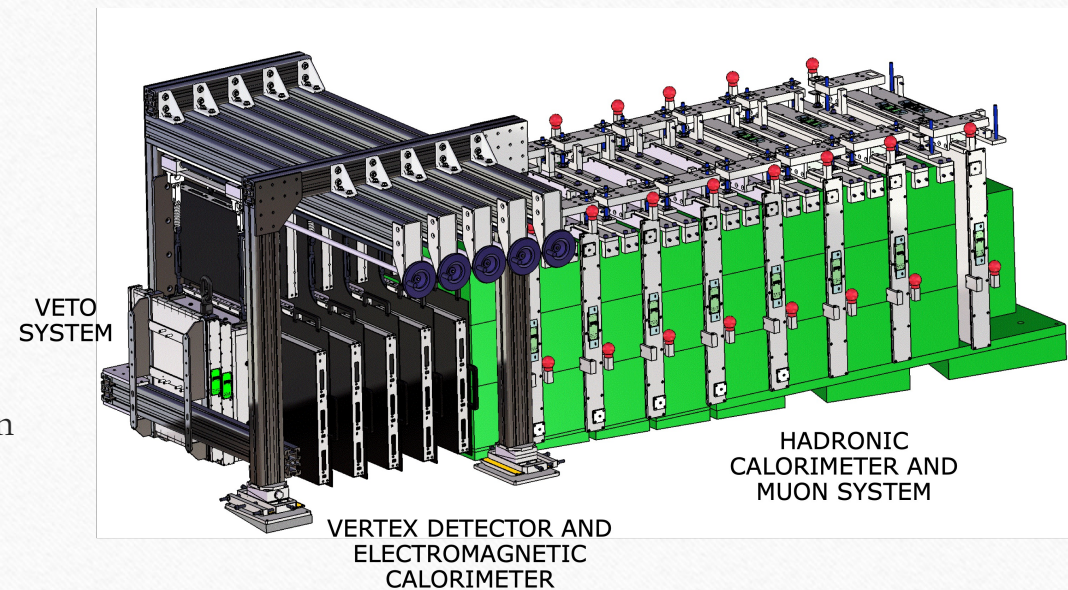

# HL-LHC is on the way

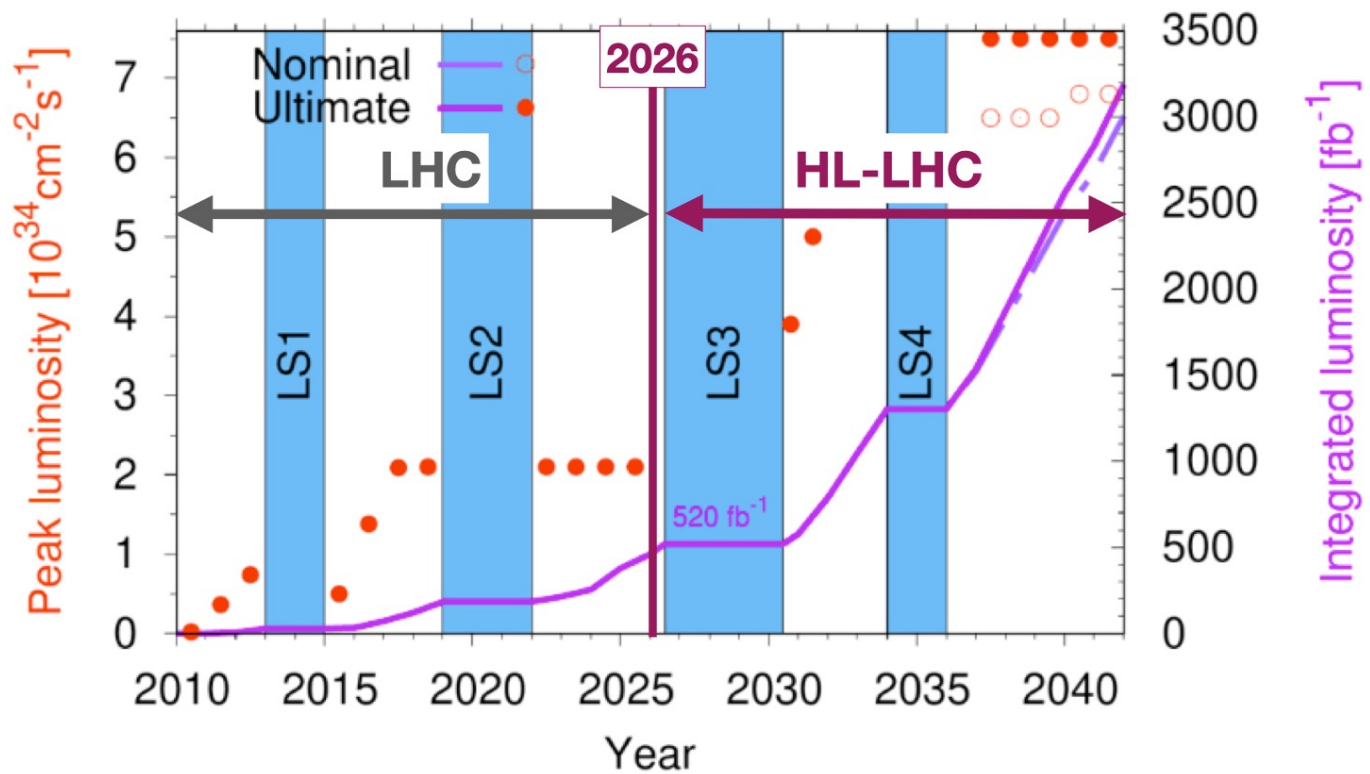

# Proposed large-scale projects at CERN, ~ 2045

## $e^+e^-$ colliders ("Higgs factories")

FCC-ee ( $e^+e^-$ , circular, 91 – 365 GeV)

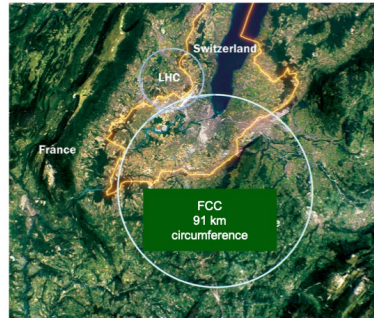

LCF ( $e^+e^-$ , linear, 91 – 240, 550 GeV)

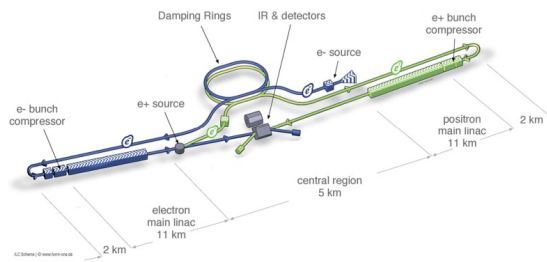

CLIC ( $e^+e^-$ , linear, 380 GeV, 1.5 TeV)

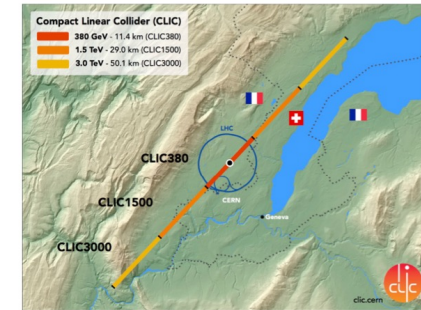

## Intermediate projects

*(Leave room (time, budget, resources) for further development of THE machine that can probe directly the energy frontier at the 10 TeV parton scale)*

LEP3 ( $e^+e^-$ , circular, 91 – 230 GeV)



LHeC (ep, circular, electron ERL, 50 GeV  $e^-$ , > 1 TeV ep collisions)

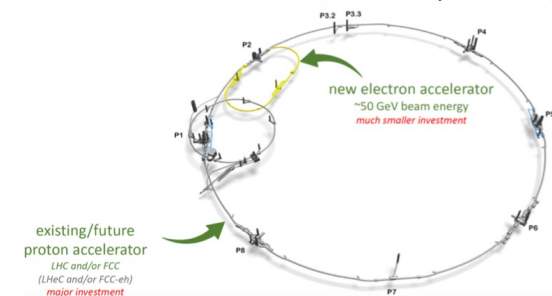

# CEPC in China

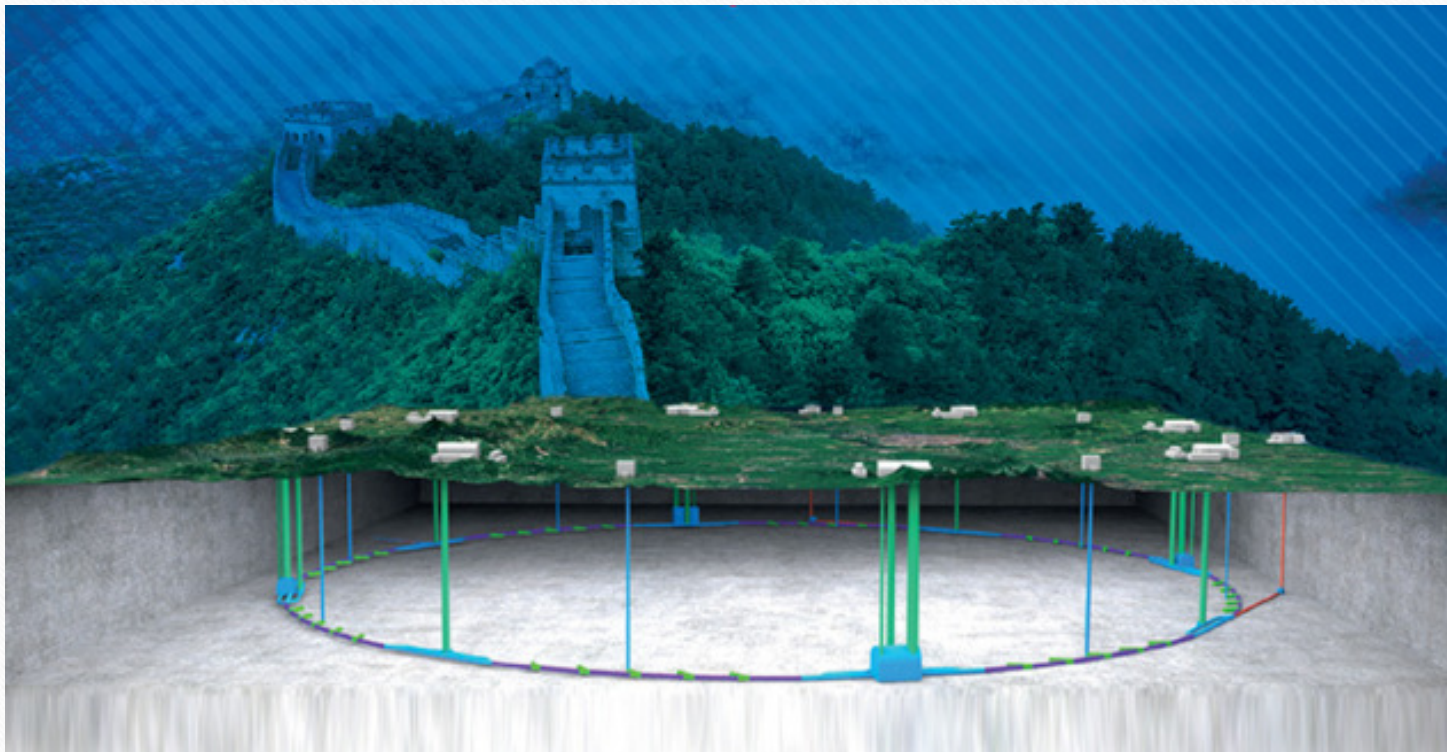

# Take-Away

