



**Fermilab**

Tabletop Efforts Toward

kHz Gravitational Wave Detection at QUAX

**Danho Ahn (on behalf of QUAX-LNL)**

Sezione di Padova, Istituto Nazionale di Fisica Nucleare, Padova 35131, Italy

# Contents

---

## Tabletop Efforts Toward kHz Gravitational Wave Detection at QUAX

- Introduction: Gravitational Wave (GW) Detection
- GW Detection by a LC Circuit in a High B Field
- SQUID Readout Chain
- State of Art Technologies
- Tuning & Optimization of Detector Circuit
- Summary

# Introduction

## Gravitational Wave Detection

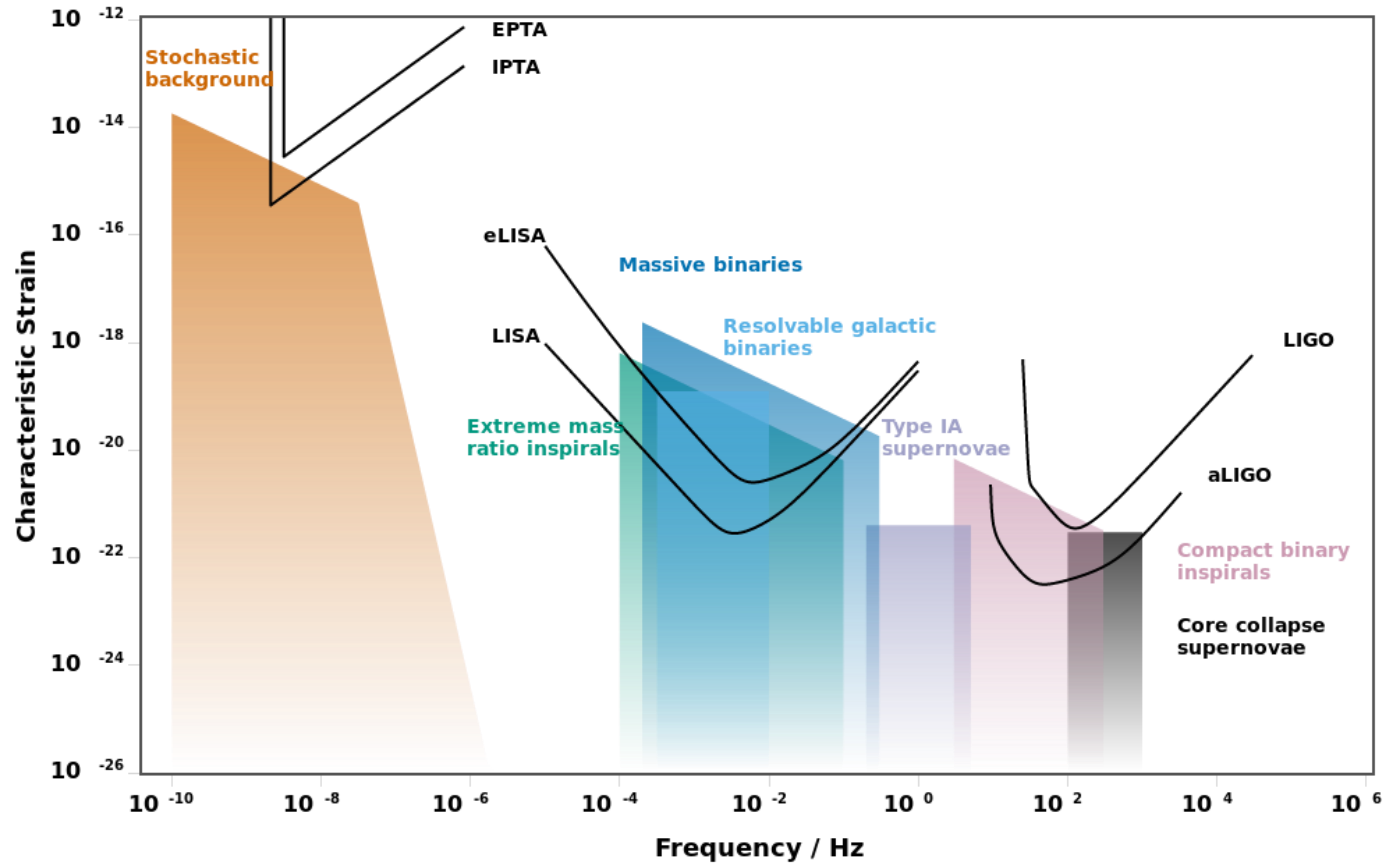

# Introduction

## Gravitational Wave Detection

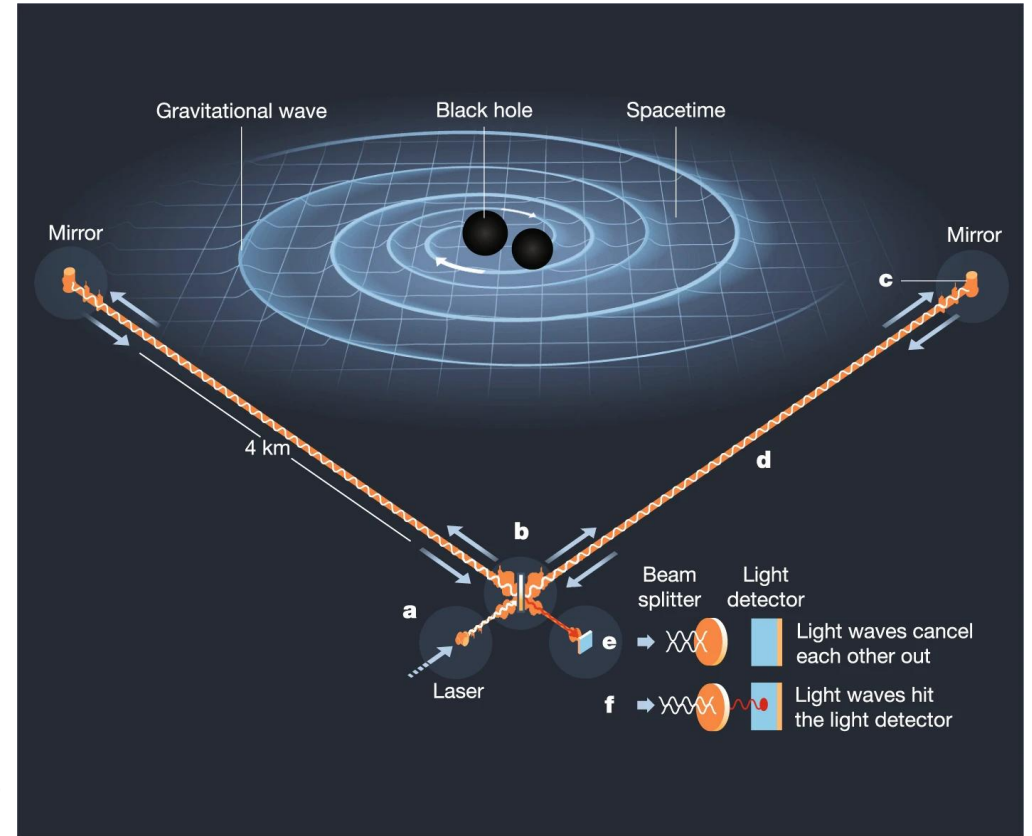
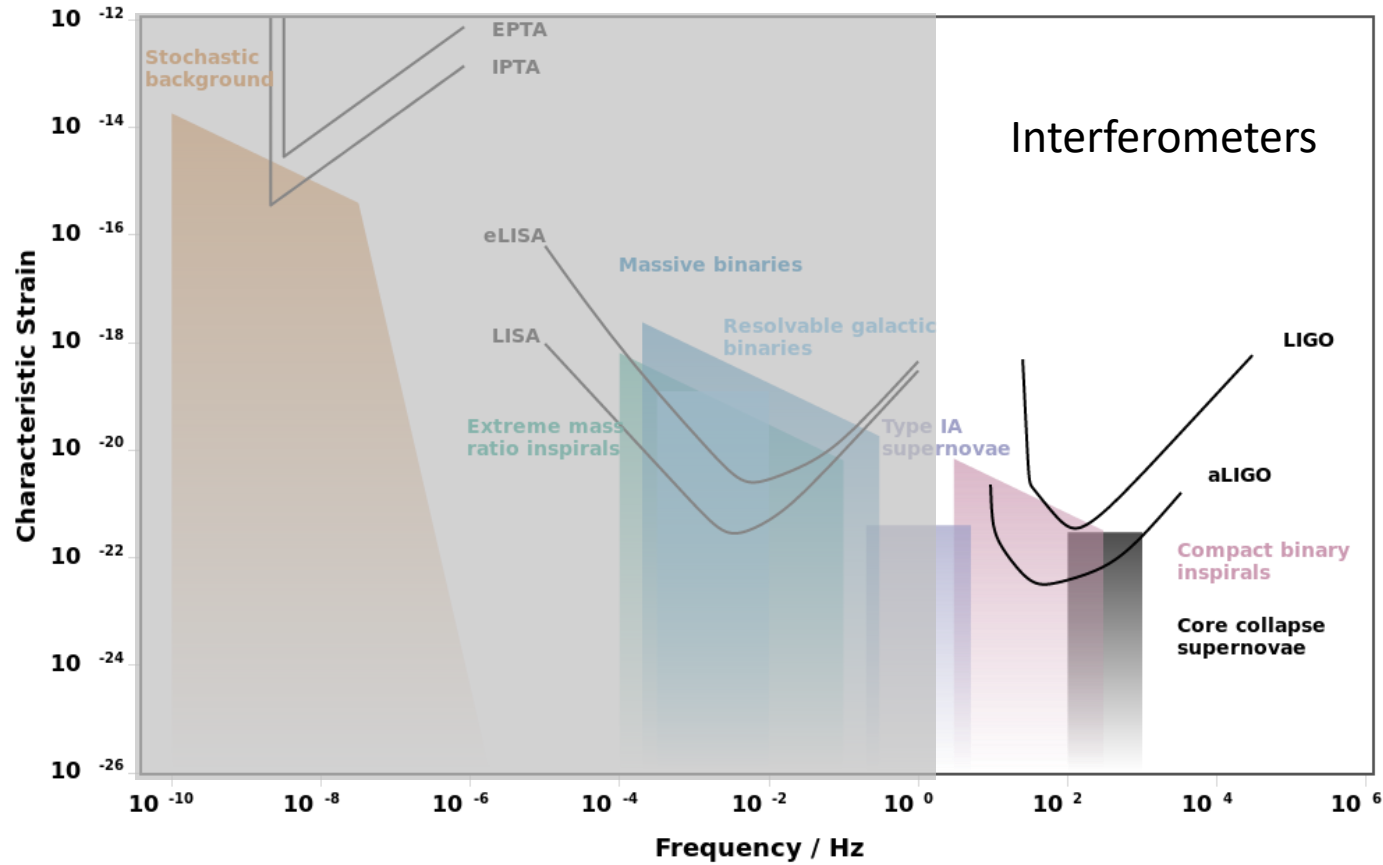

# Introduction

## Gravitational Wave Detection

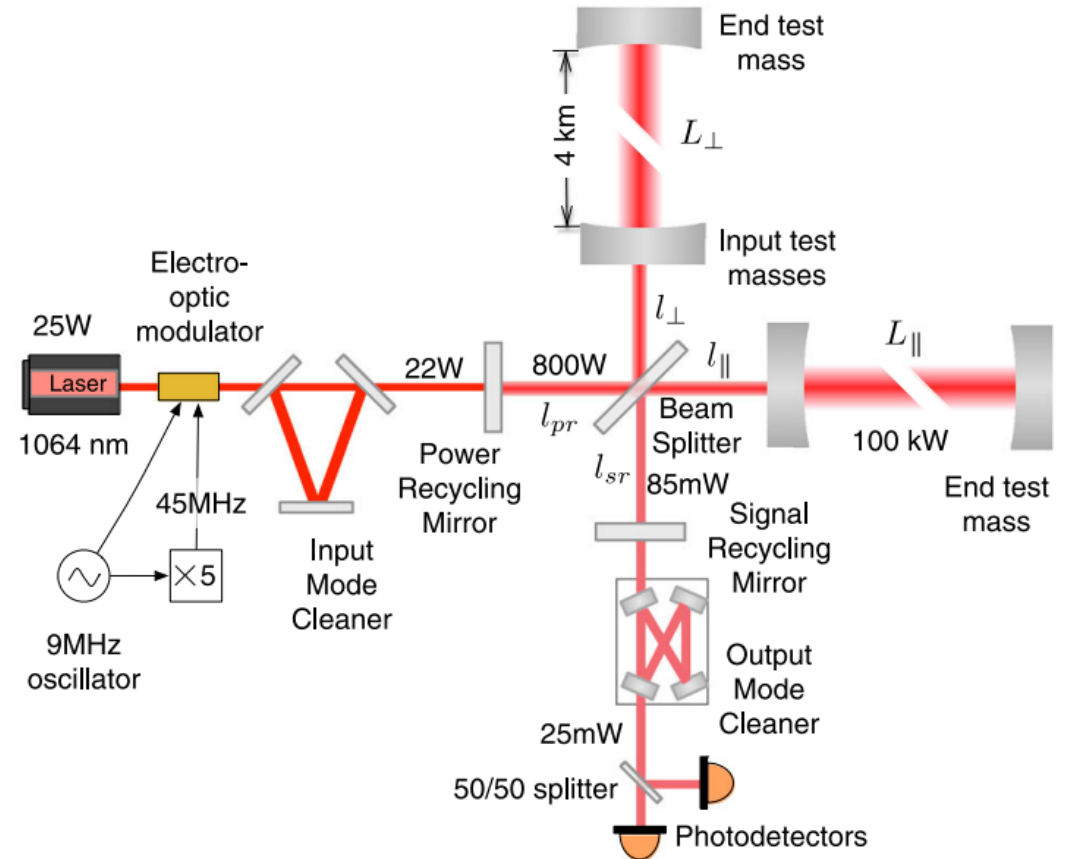
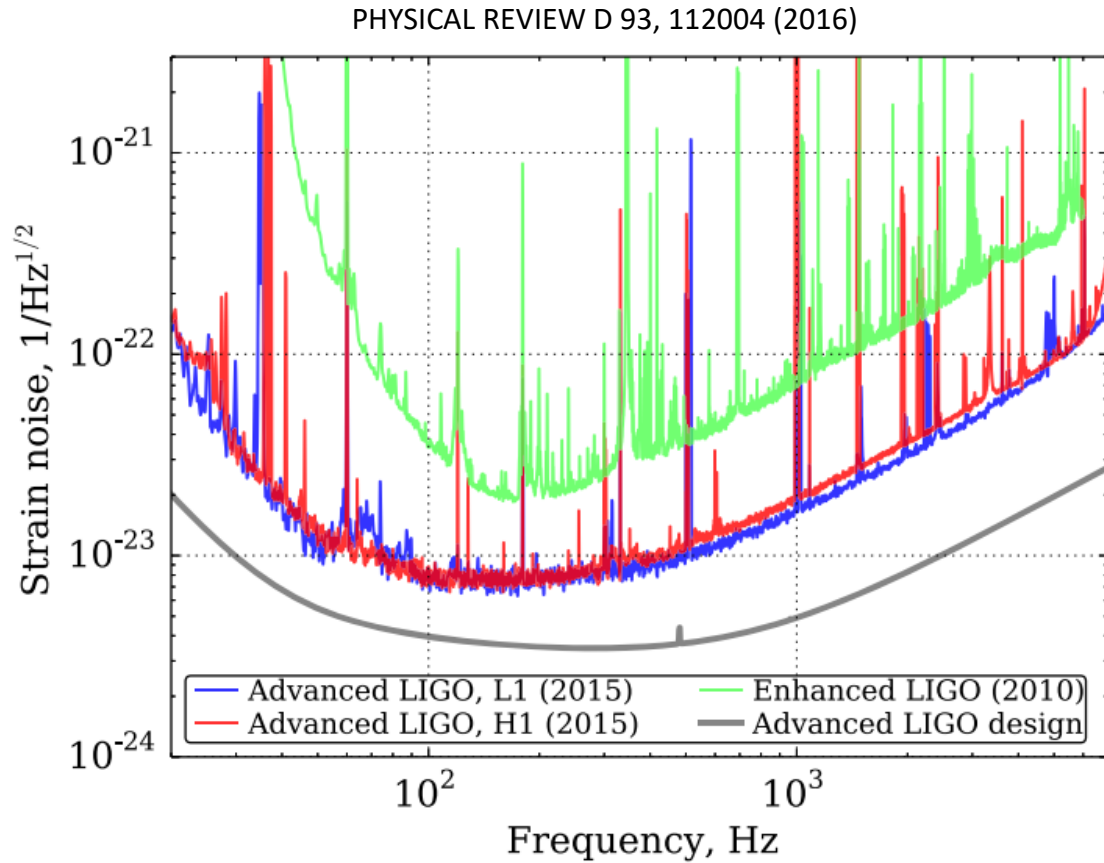

# Introduction

## Gravitational Wave Detection

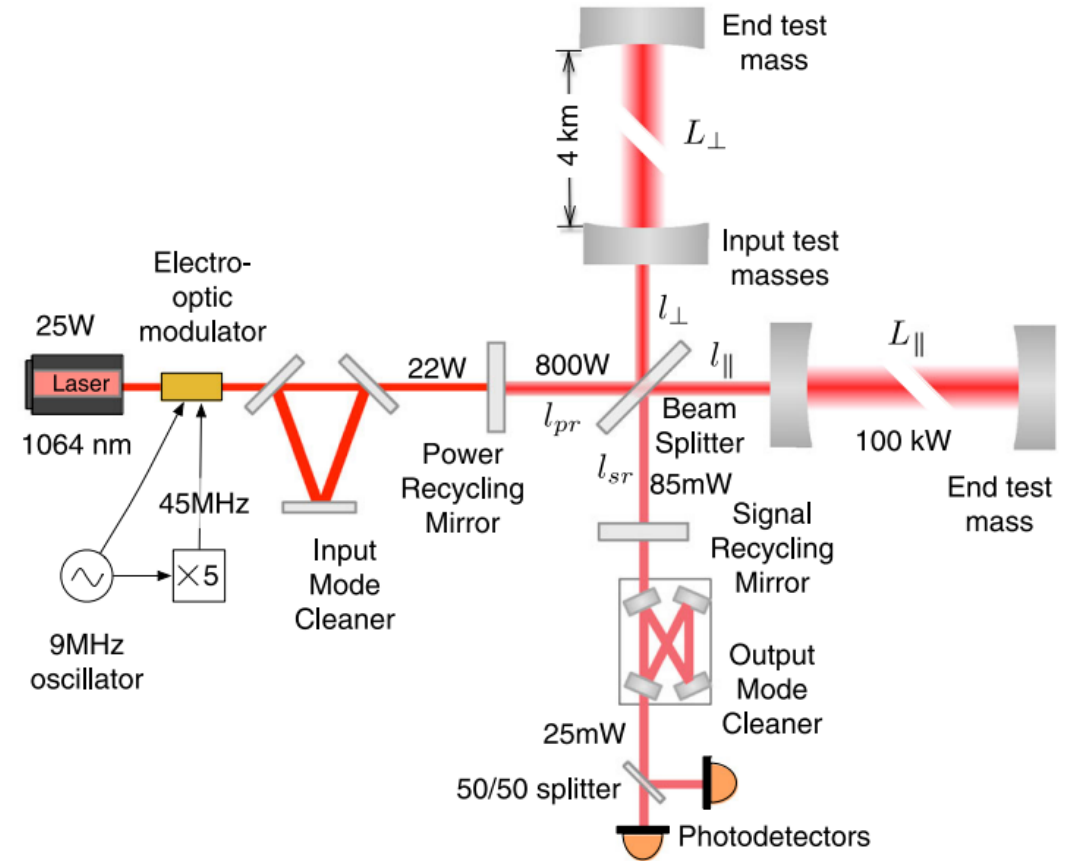
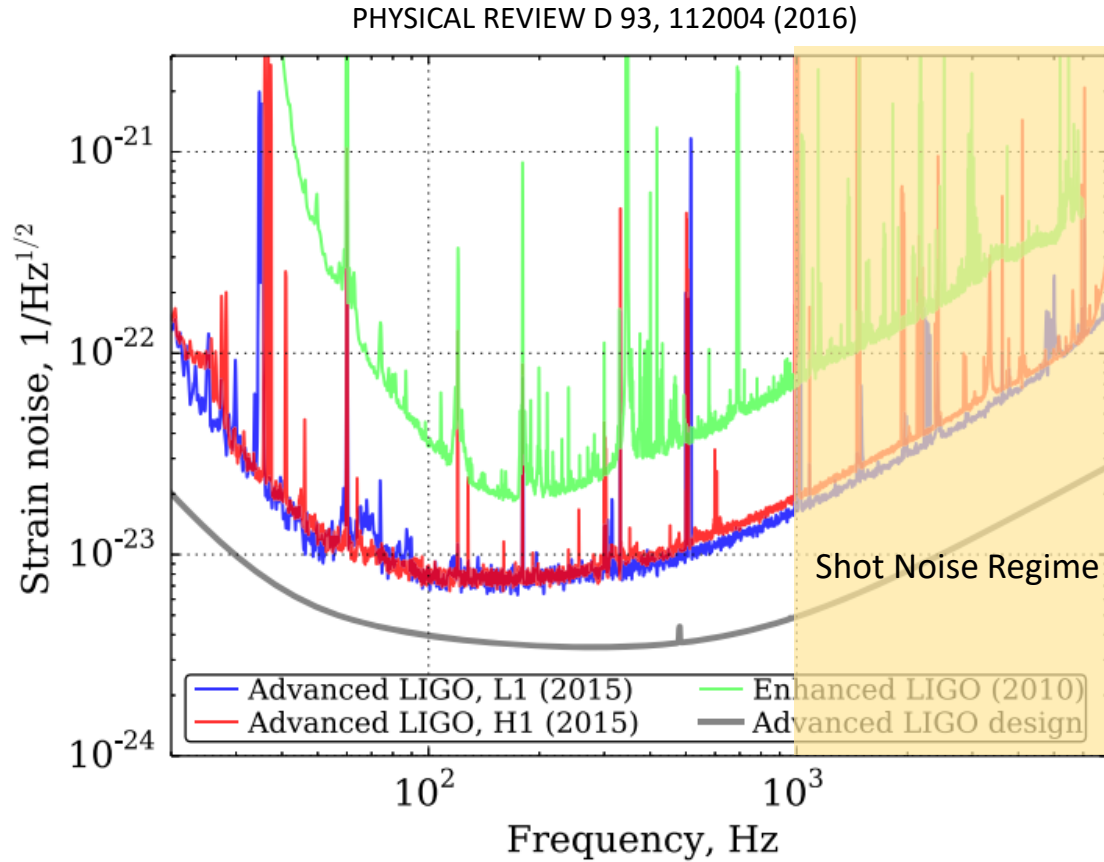

# Introduction

## Gravitational Wave Detection

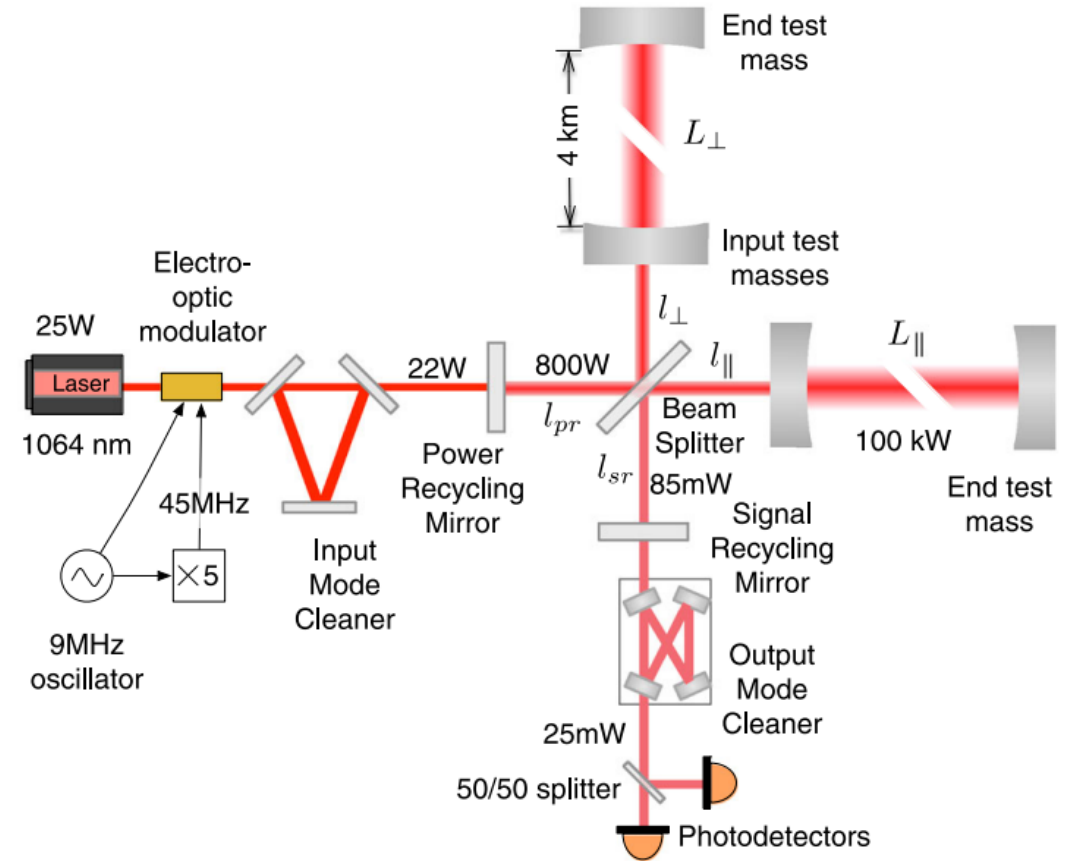
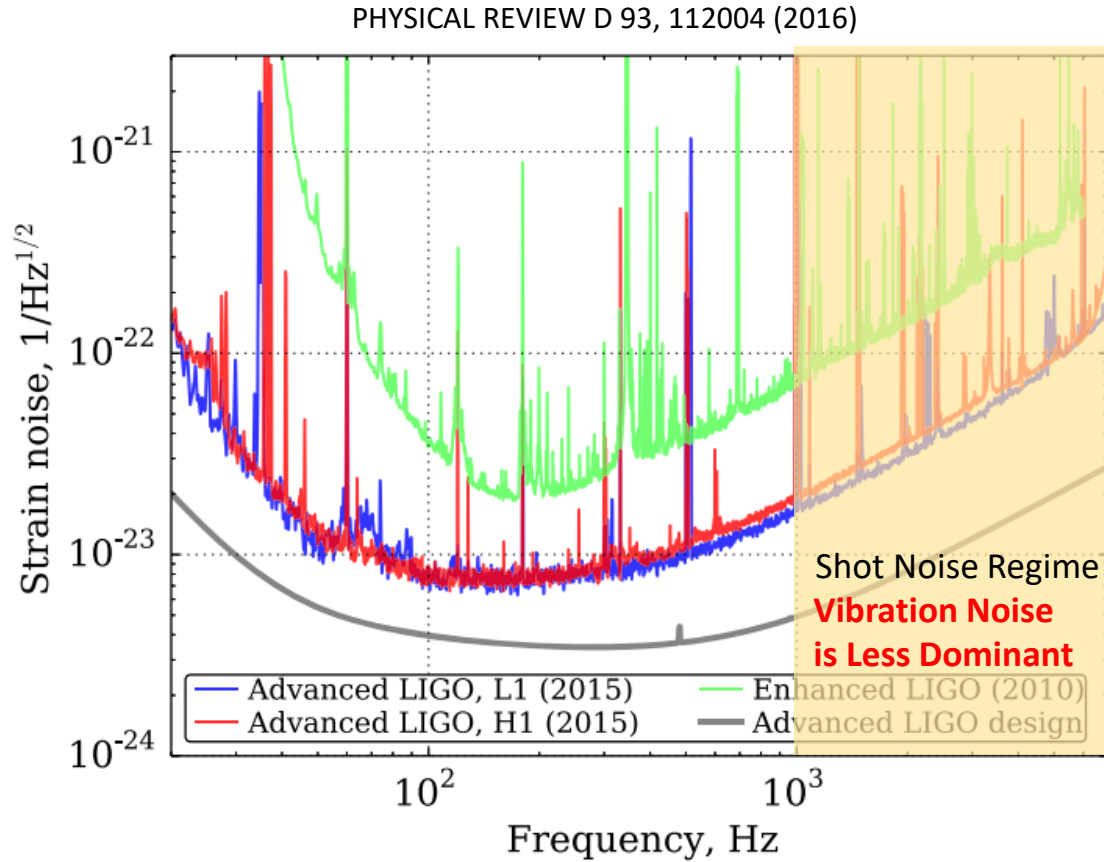

# Introduction

## Gravitational Wave Detection

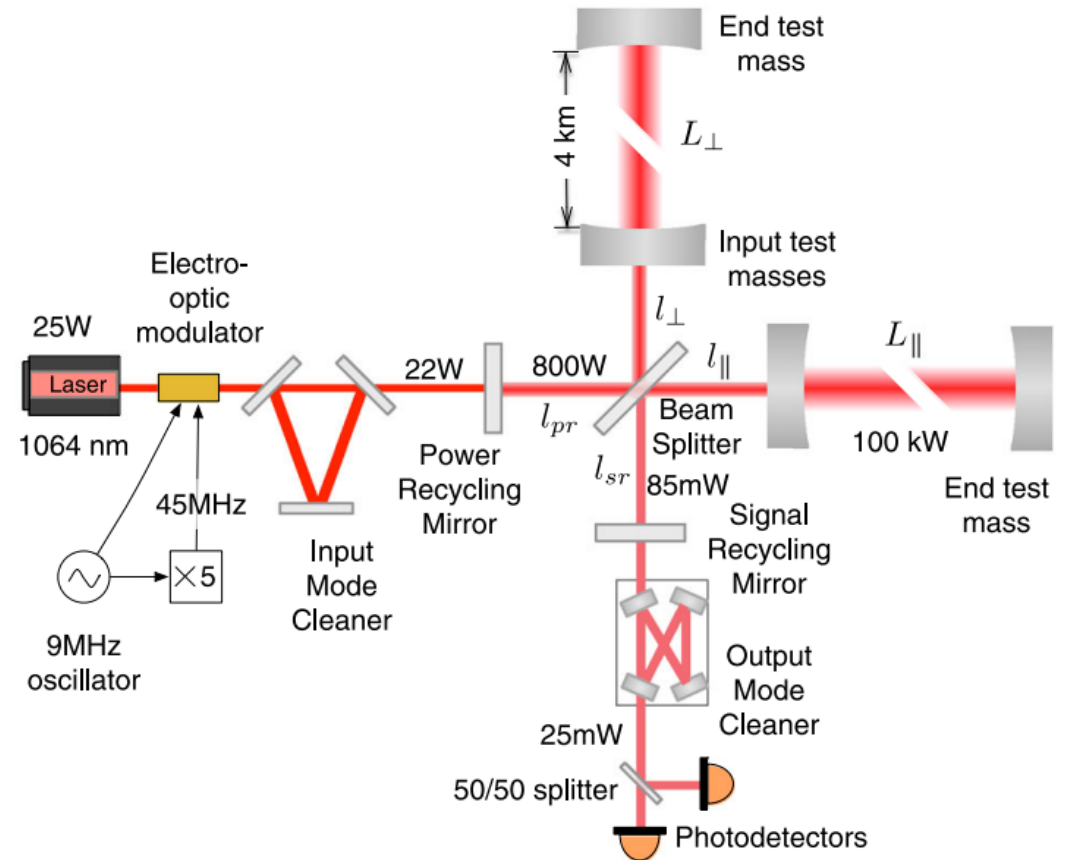
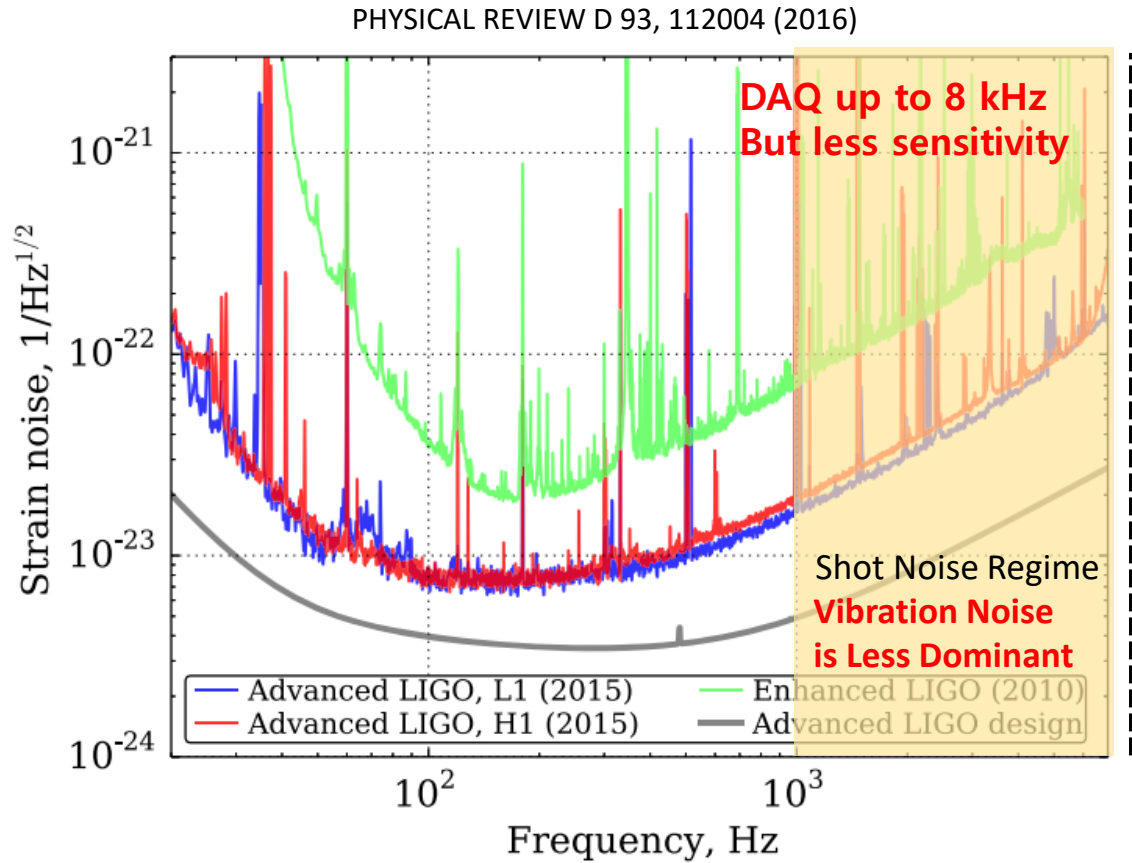

# Introduction

## Gravitational Wave Detection

Extend Detection Frequency  $O(10 \text{ kHz})$

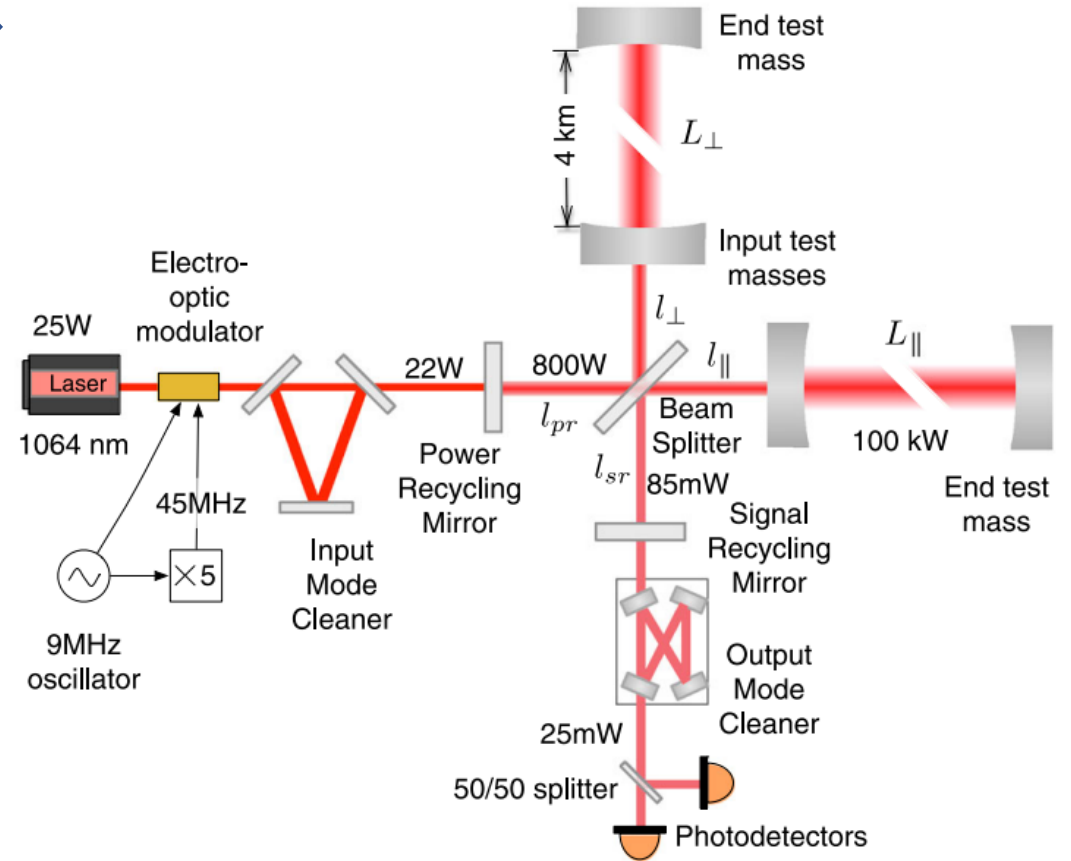
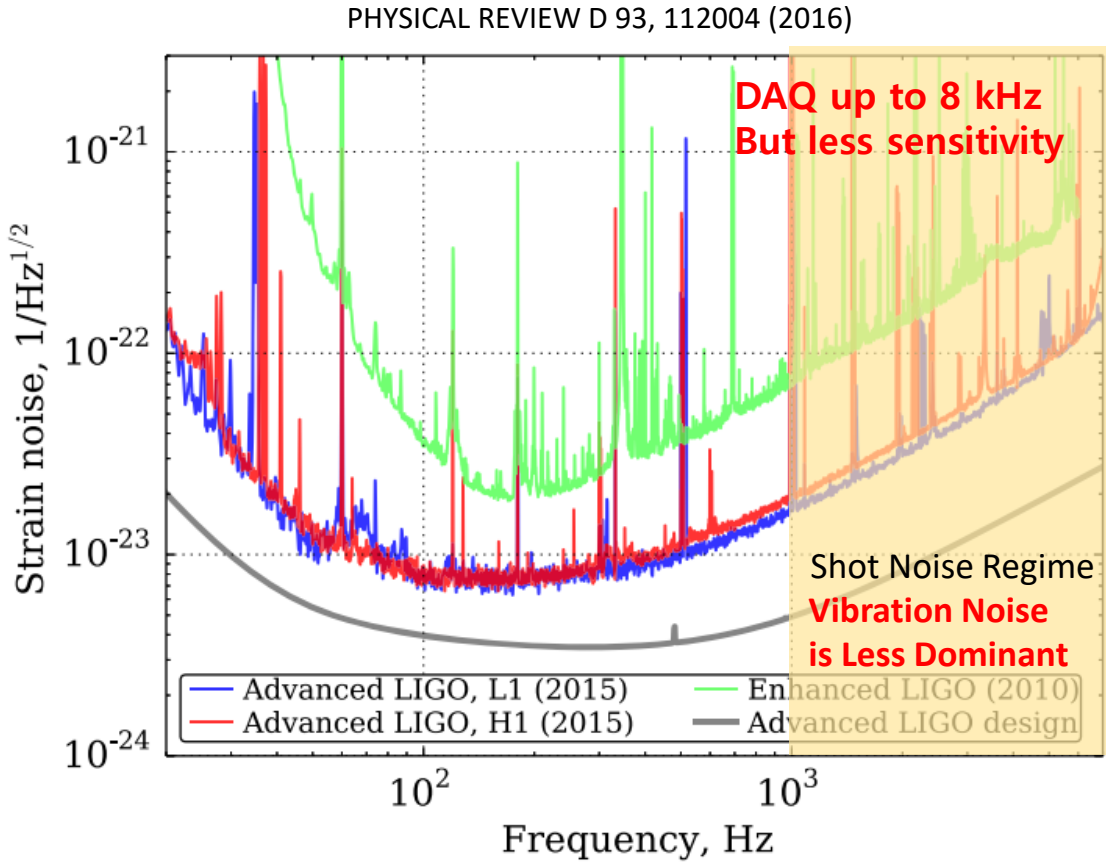

# Introduction

## Gravitational Wave Detection

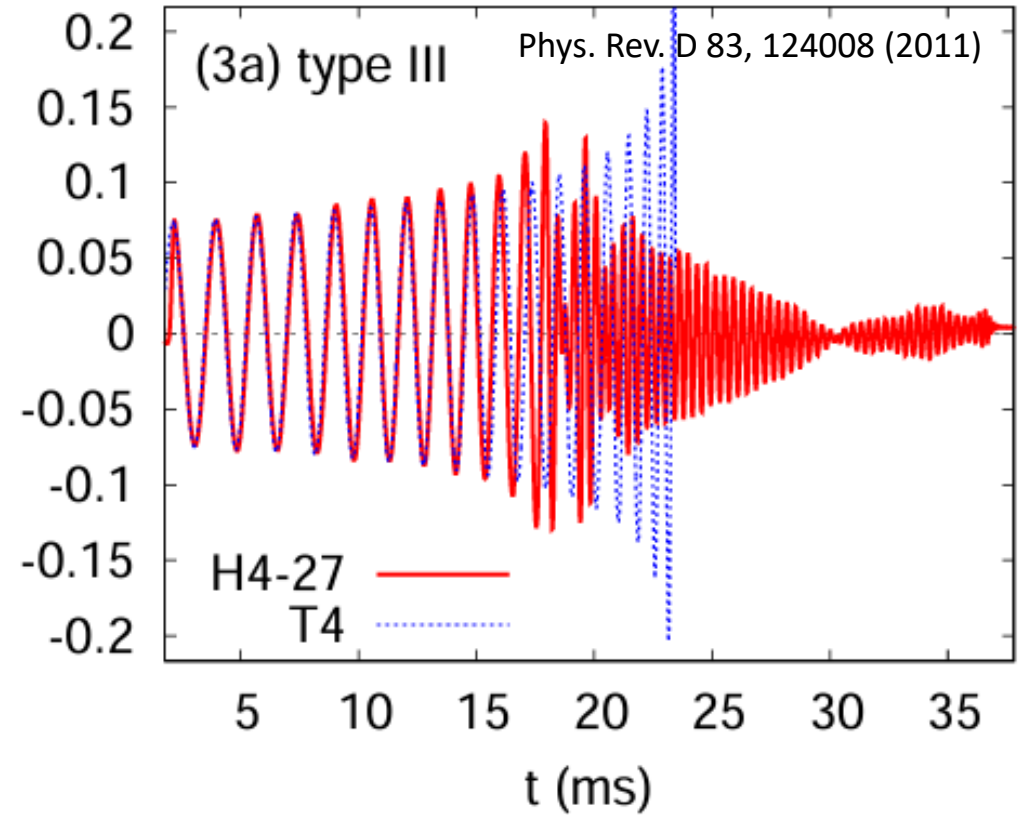
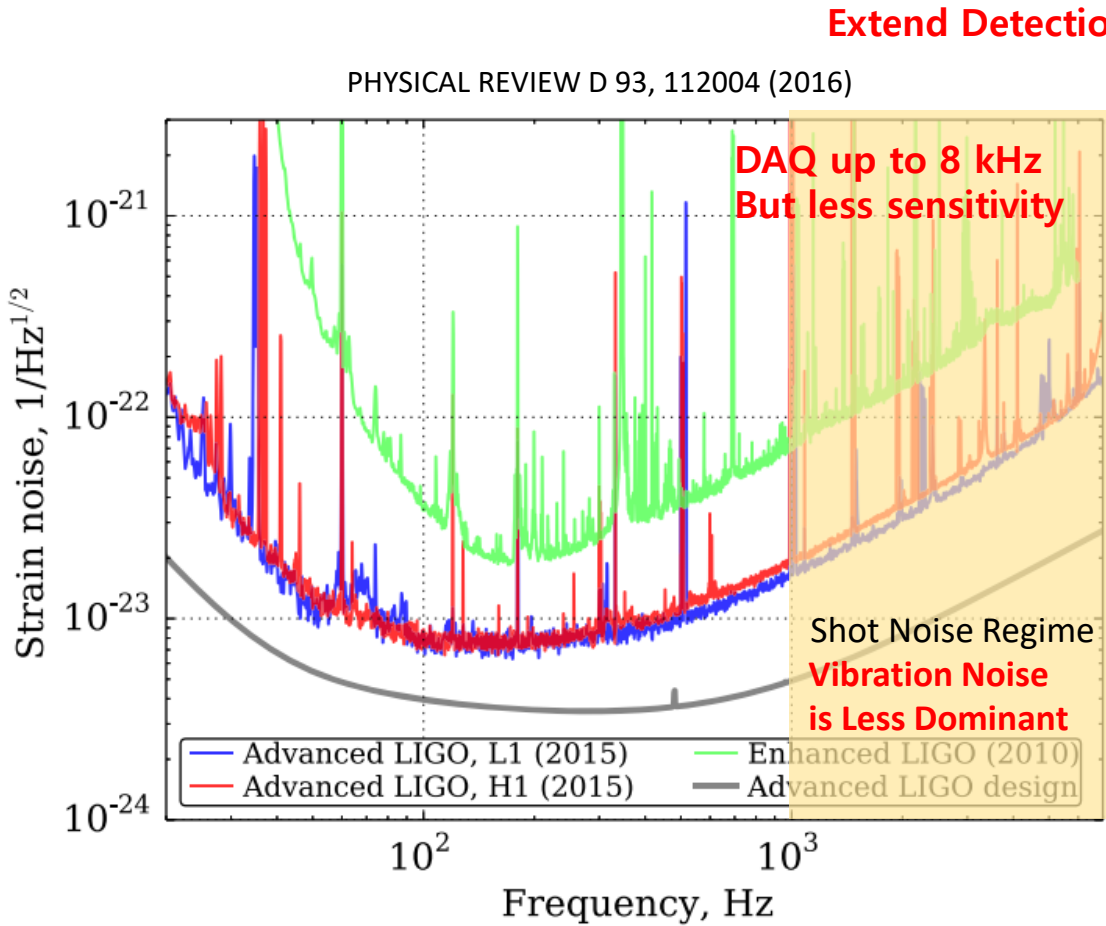

Neutron Star Binary Signal Can Give kHz Gravitational Wave Signal

# Introduction

## Gravitational Wave Detection

Extend Detection Frequency  $O(10 \text{ kHz})$

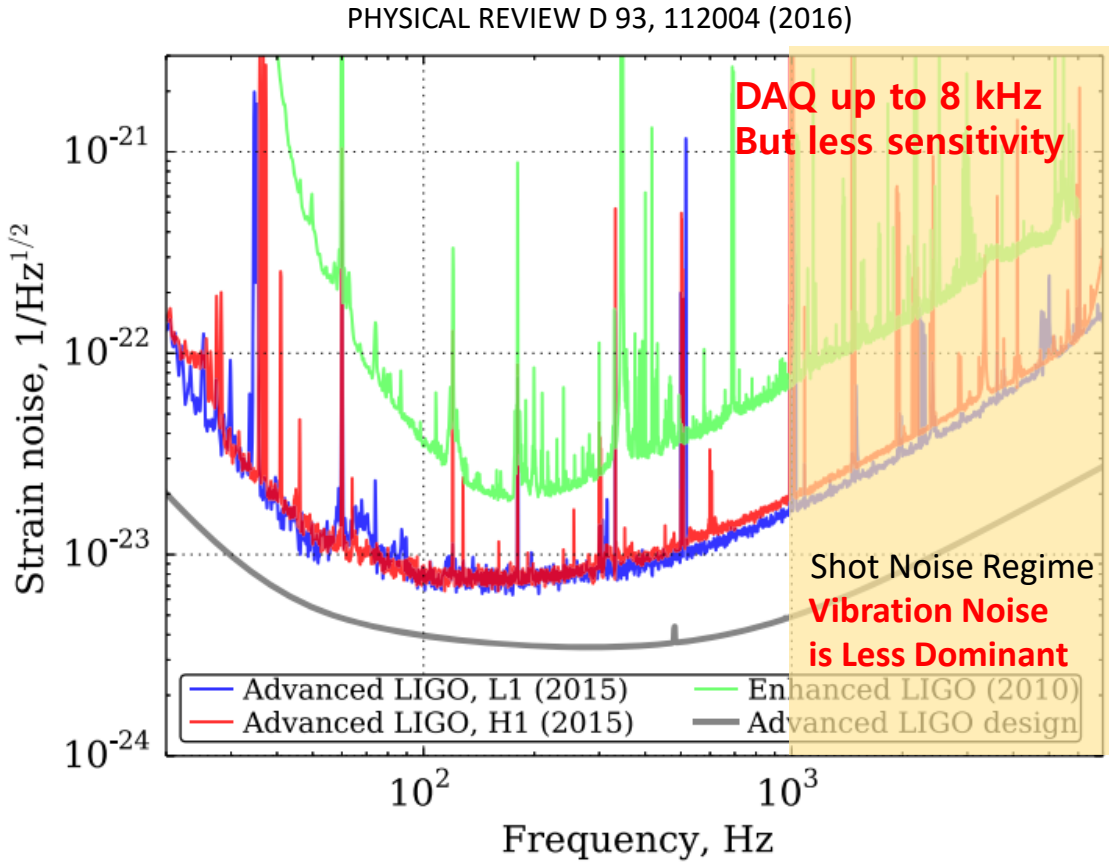

Fourier spectrum ( $h_{\text{eff}}$  @ 100 Mpc)

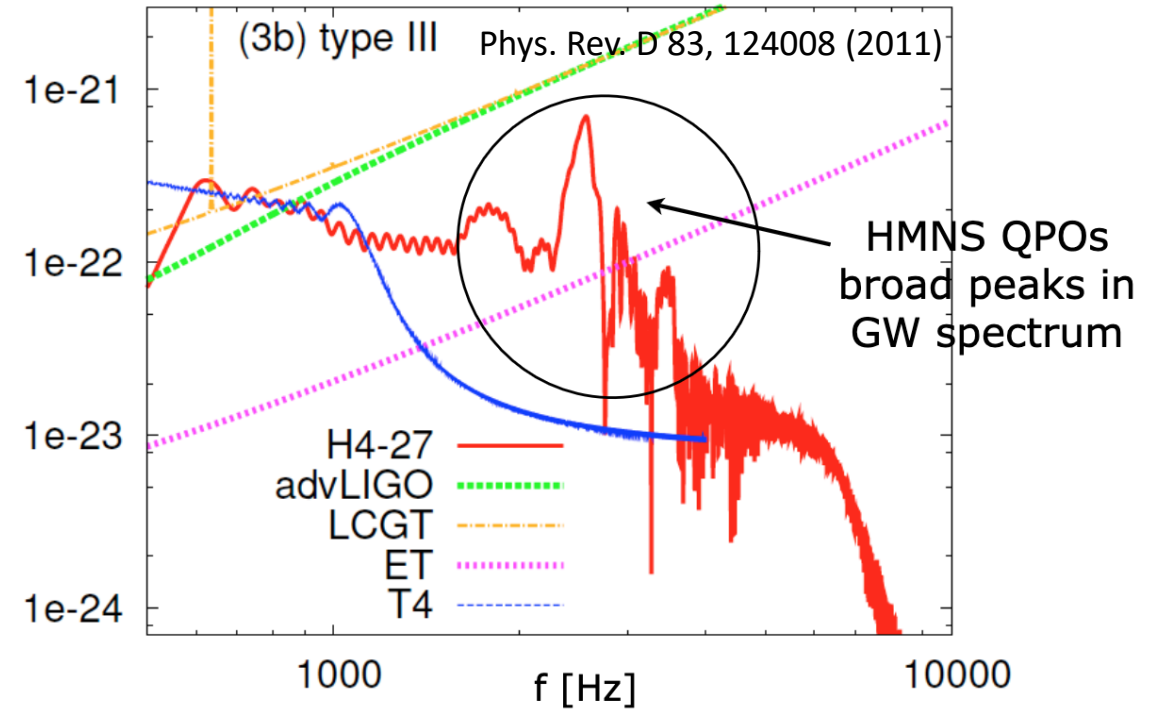

Higher Frequency Signals up to 10 kHz

# Introduction

## Gravitational Wave Detection

Extend Detection Frequency  $\sim 10$  kHz

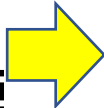
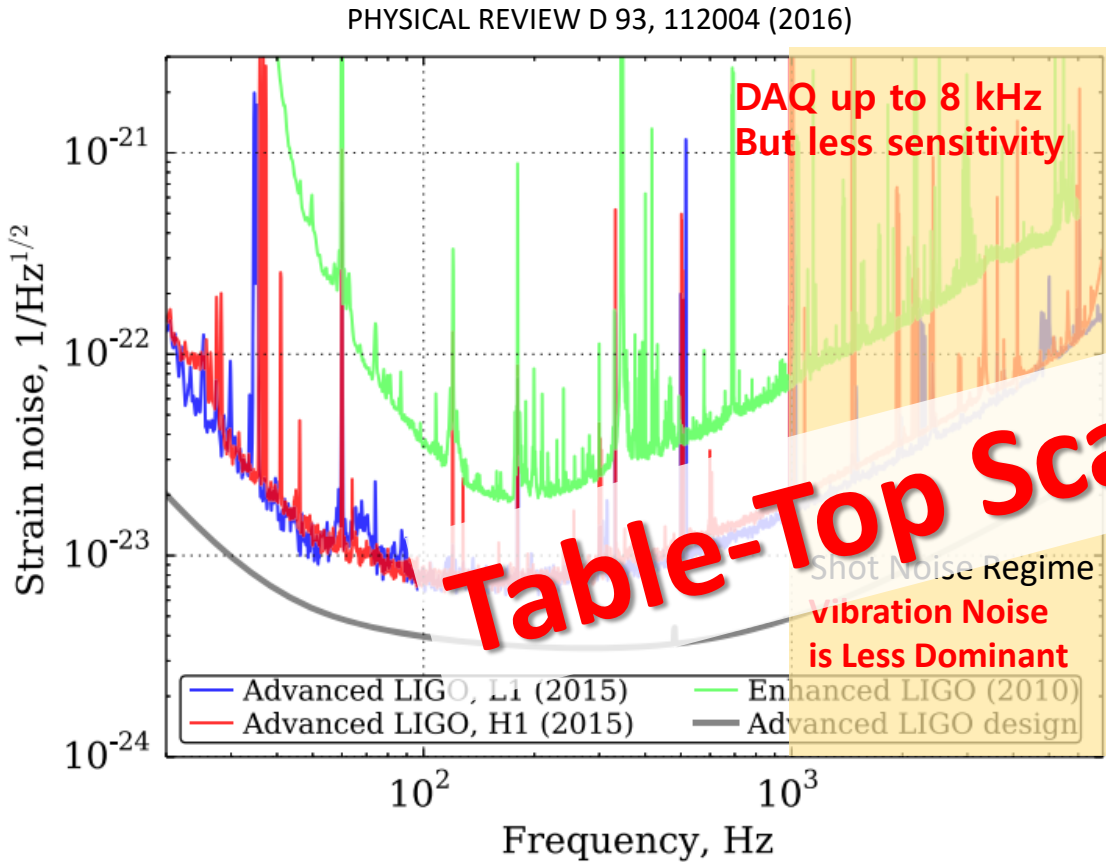

Fourier spectrum ( $h_{\text{eff}}$  @ 100 Mpc)

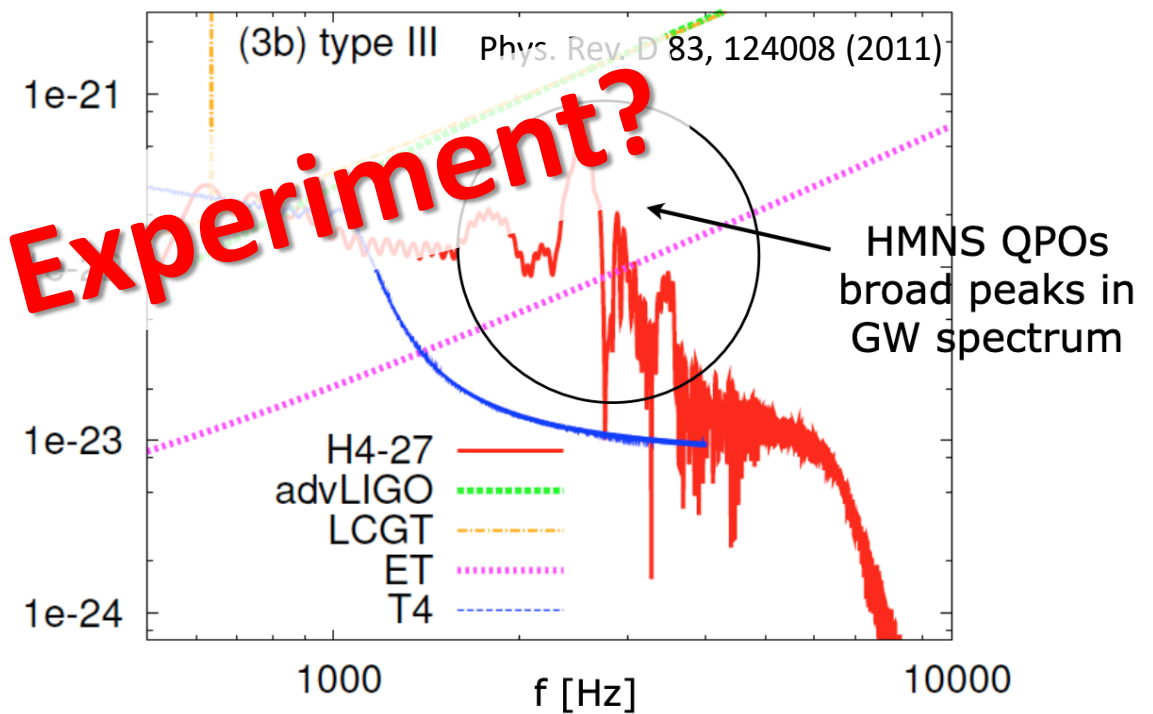

**Table-Top Scale Experiment?**

# Introduction

## Table-Top Scale Gravitational Wave Detection with QUAX Infrastructure



### QUAX-BLU

10 mK Base Temperature

9 T Magnet

Single Microwave Photon Counter

Axion/Ferromagnetic Haloscope

### QUAX

Sub-100 mK

9 T Magnet

Quantum-Limited Noise Amplifier

Axion Haloscope

### QUAX-RED

Sub-100 mK



14 T Magnet

Quantum-Limited Noise Amplifier

Axion Haloscope, Dark Photon

# Introduction

## Table-Top Scale Gravitational Wave Detection with QUAX Infrastructure

	<p><b>15:00</b> Today 15:00</p> <p><b>Status and perspectives of the QUAX-LNL 10 GHz axion h...</b> <i>Raffaele Di Vora</i></p>	
<p><b>QUAX-10</b></p>	<p><b>An array of acoustic resonators for the detection of high-f...</b> <i>Leonardo Mariani</i></p>	<p><b>QUAX-RED</b></p>
<p>10 mK Base Temperature</p>	<p><b>Gravitational waves from high-power twisted beams of light</b> <i>Killian Martineau</i></p>	<p>Sub-100 mK</p>
<p>9 T Magnet</p>	<p>9 T Magnet</p>	<p>14 T Magnet</p>
<p>Single Microwave Photon Counter</p>	<p>Quantum-Limited Noise Amplifier</p>	<p>Quantum-Limited Noise Amplifier</p>
<p>Axion/Ferromagnetic Haloscope</p>	<p>Axion Haloscope</p>	<p>Axion Haloscope, Dark Photon</p>

# Introduction

## Revisiting AURIGA Experiment at INFN-LNL

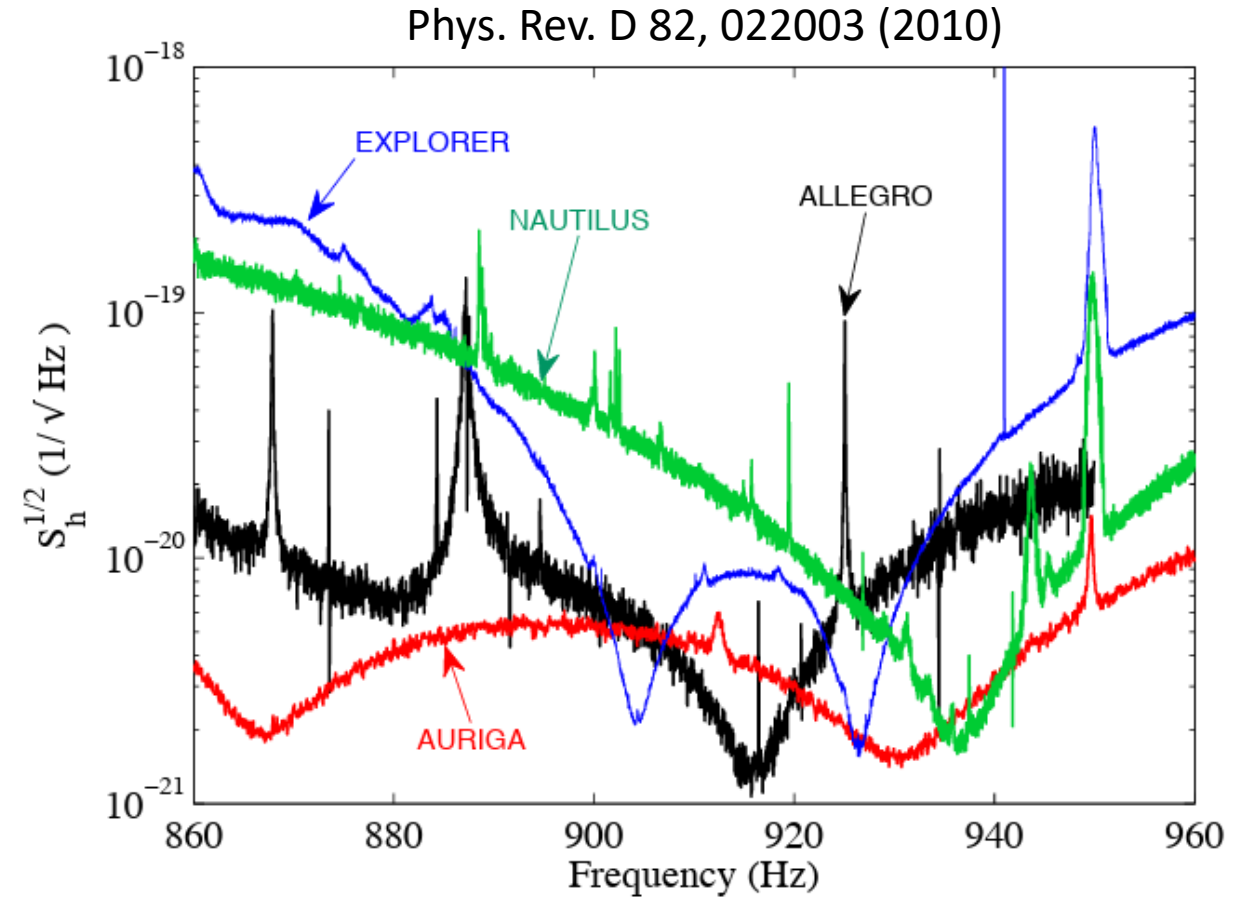
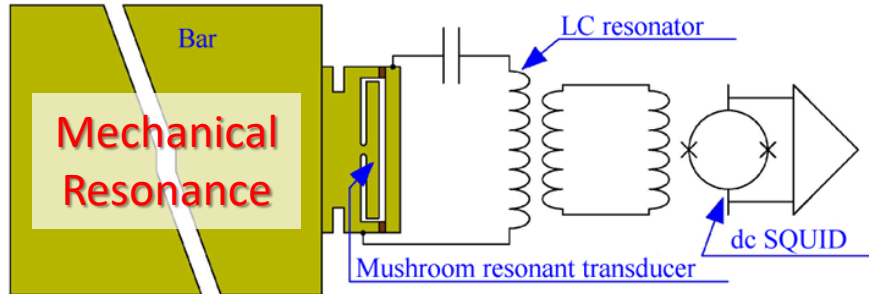

# Introduction

## Revisiting AURIGA Experiment at INFN-LNL

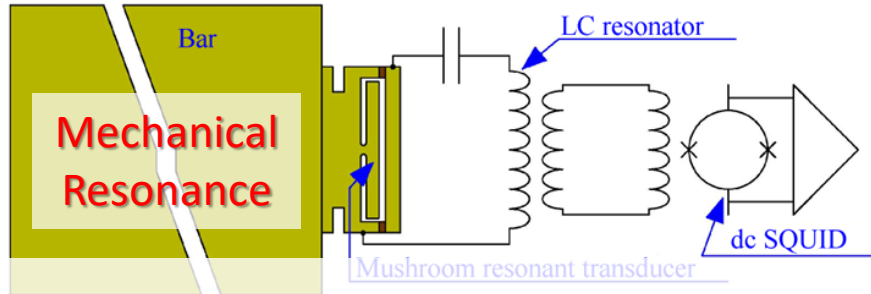

**Signal  $\propto$  Mass x Length x  $Q_{\text{mech}}$**

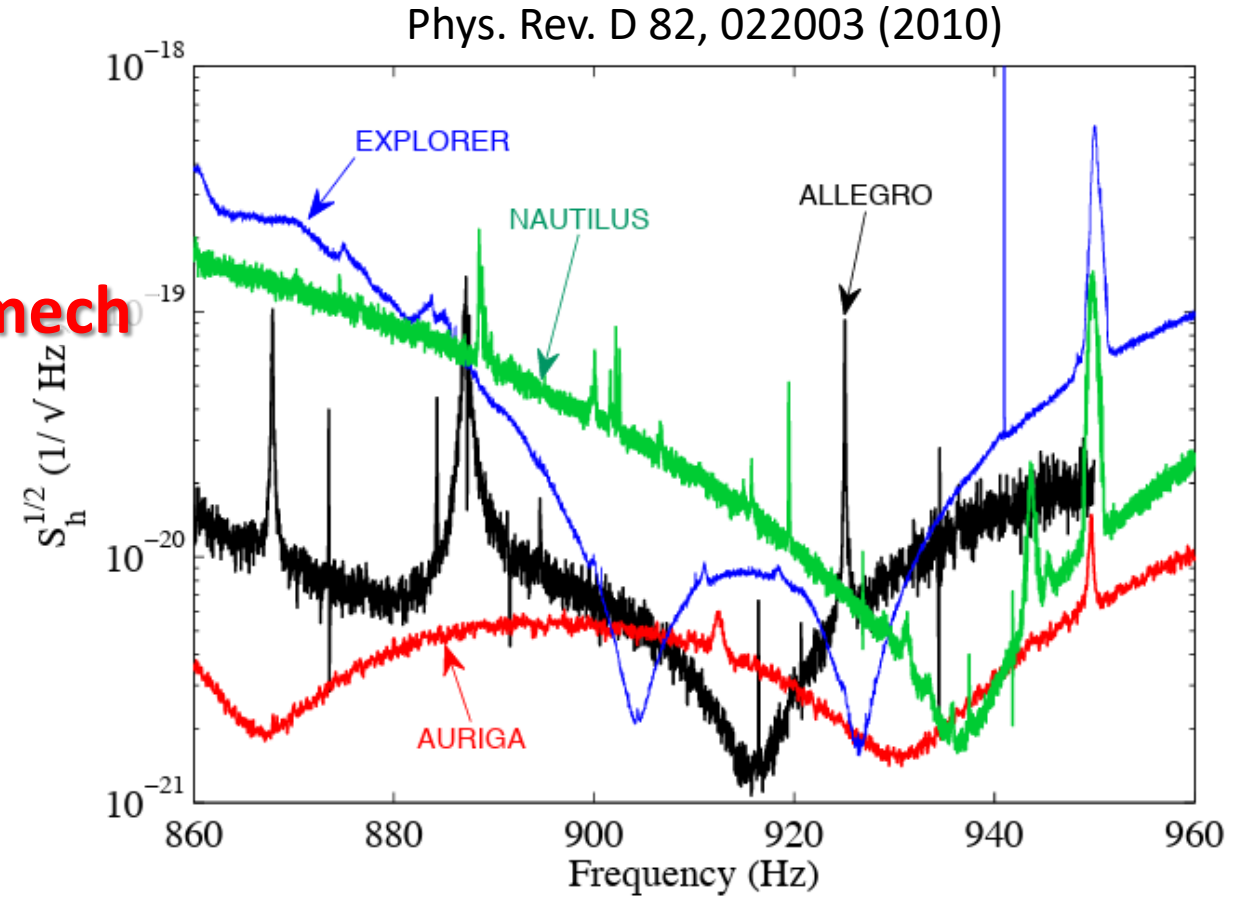

# Introduction

## Revisiting AURIGA Experiment at INFN-LNL

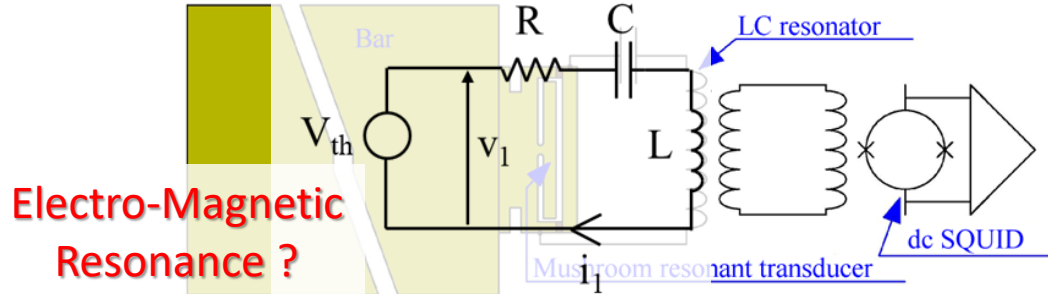

Pierluigi Fortini, Enrico Montanari,  
**Antonello Ortolan**, Gerhard Schäfer,  
Gravitational Wave Interaction with Normal  
and Superconducting Circuits, Annals of  
Physics, Volume 248, Issue 1, (1996)

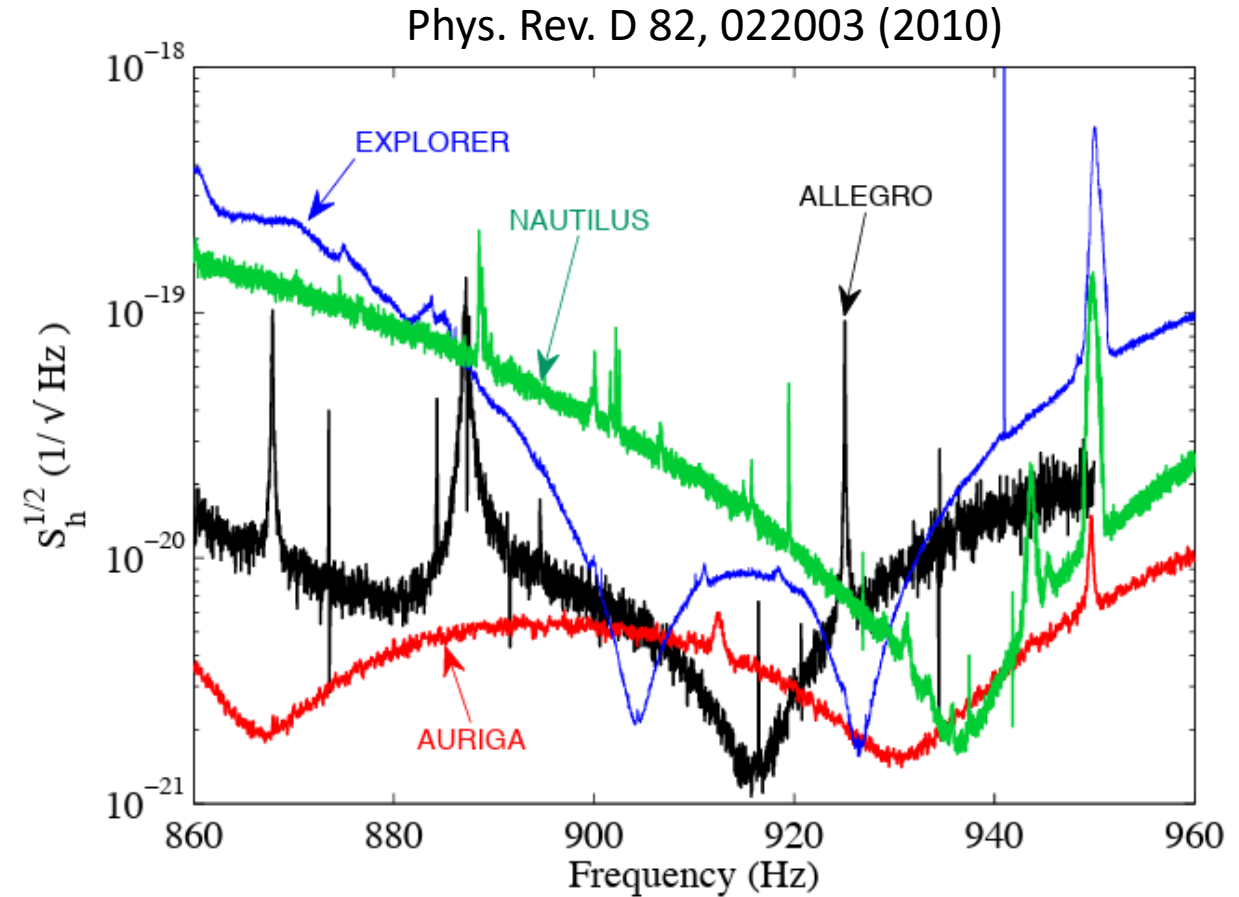

# Introduction

## Revisiting AURIGA Experiment at INFN-LNL

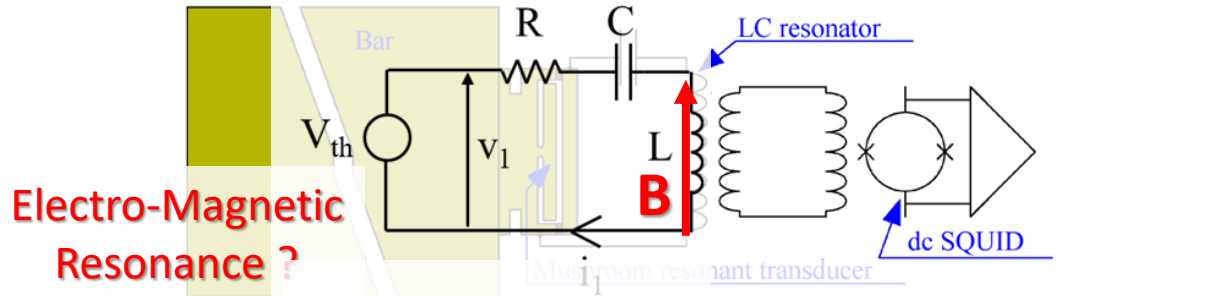

Electro-Magnetic Resonance ?

**Signal  $\propto B \times A_{pickup}$**

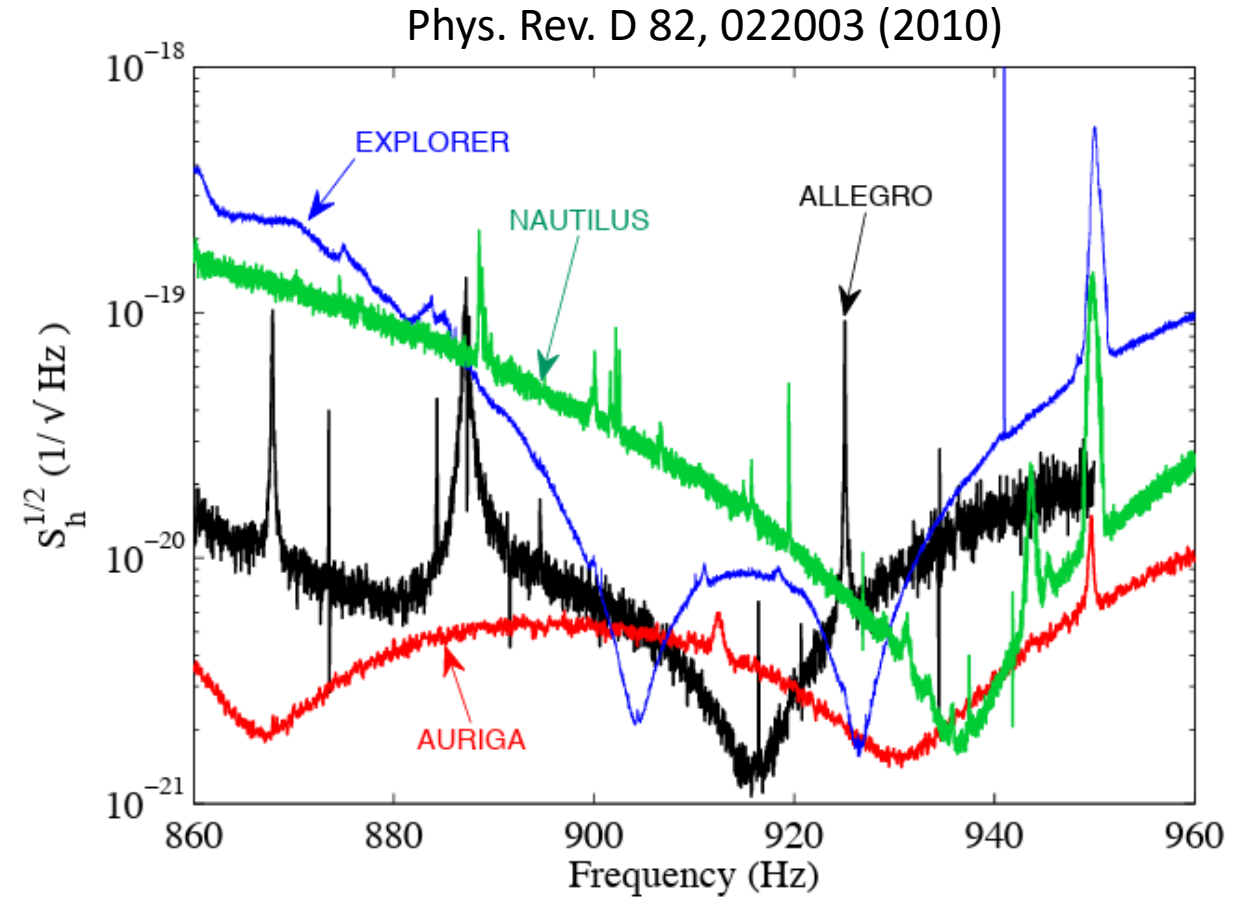

# Introduction

## Revisiting AURIGA Experiment at INFN-LNL

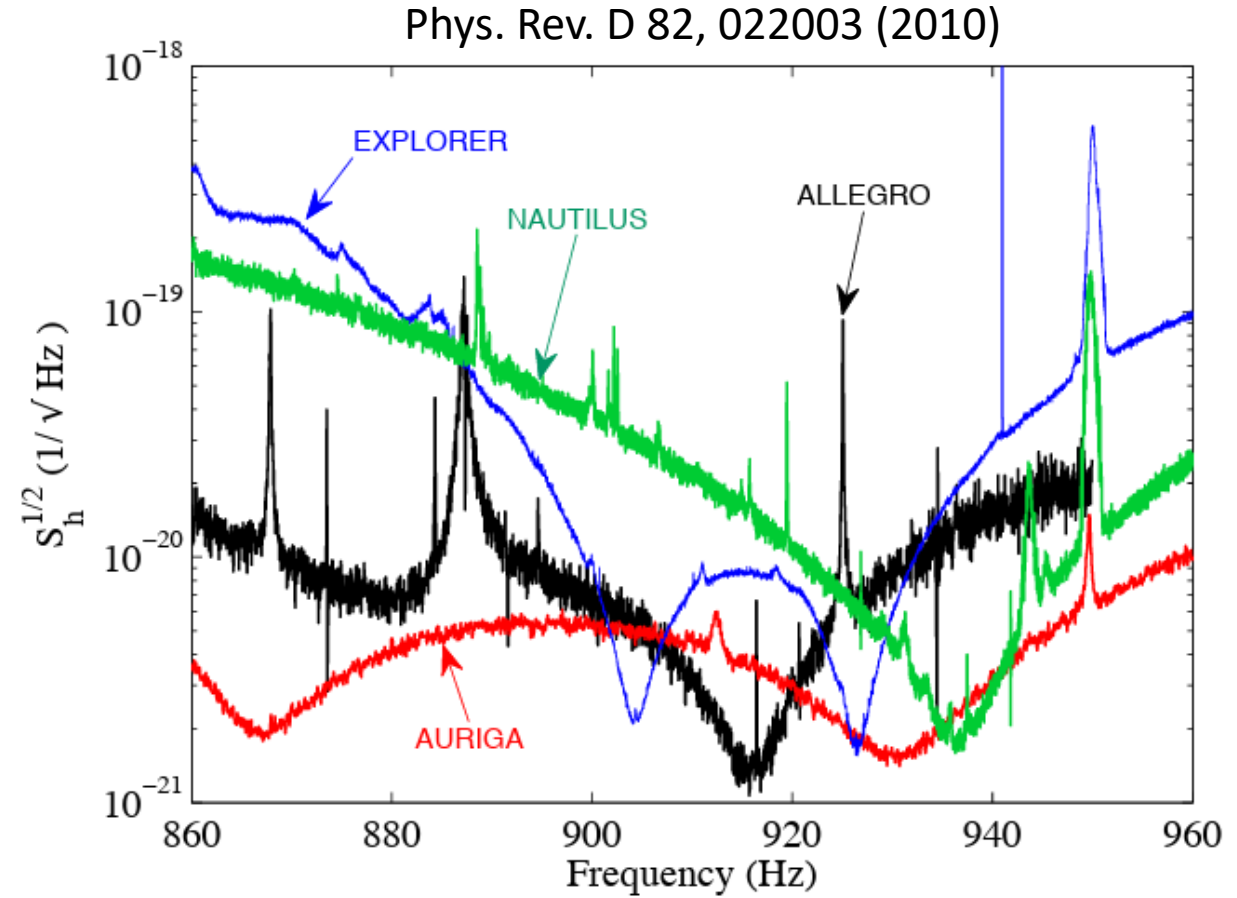
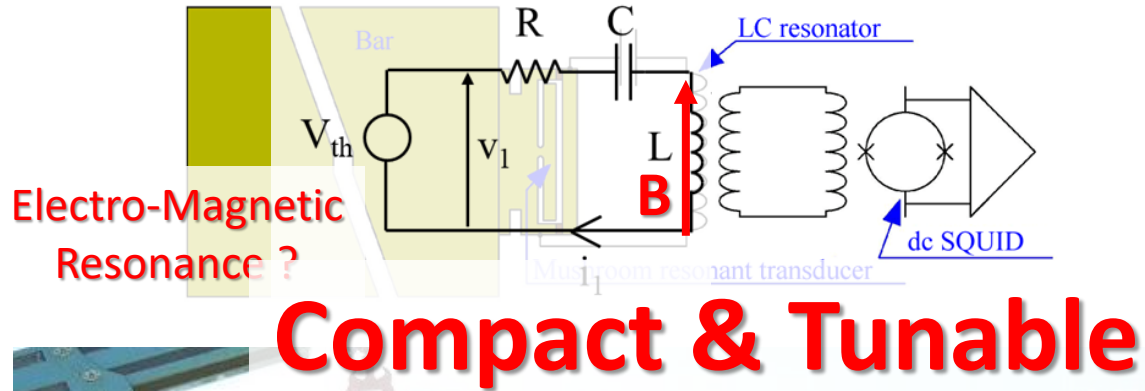

# GW Detection by LC Circuit in a High B Field

## Static Magnetic Field in a Gravitational Wave

$$\lambda_{GW} (\sim 10 \text{ km}) \gg \lambda_{Det} (\sim 1 \text{ m})$$

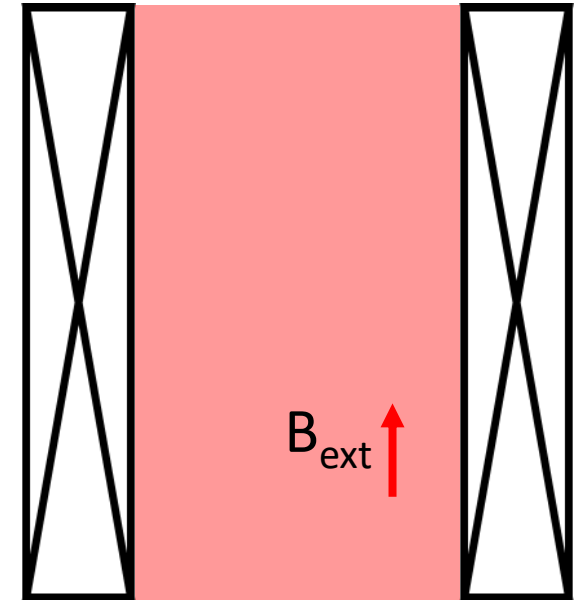
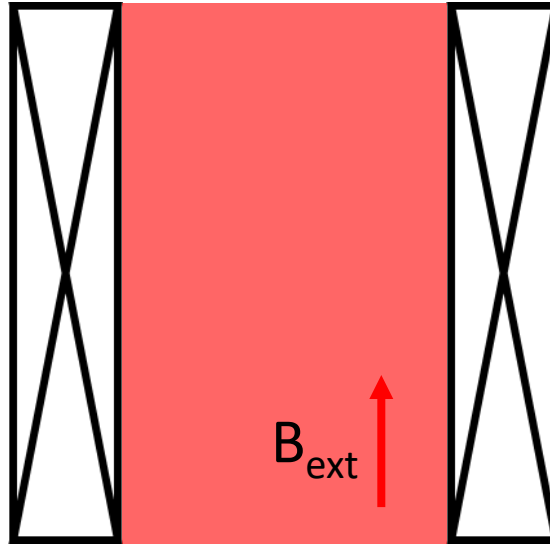
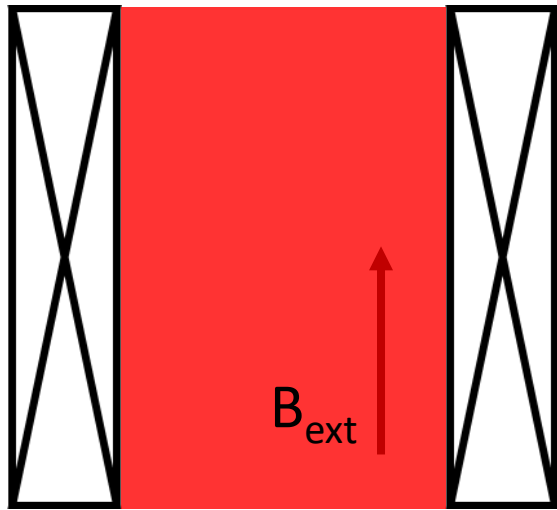

$h^+$

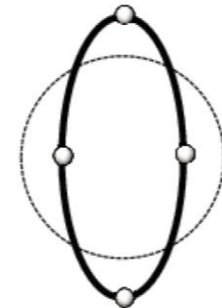
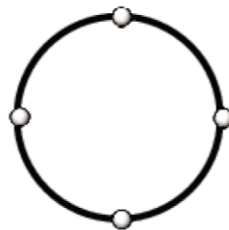
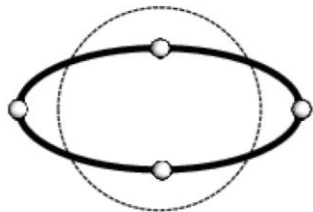

# GW Detection by LC Circuit in a High B Field

## Static Magnetic Field in a Gravitational Wave

$$\lambda_{GW}(\sim 10 \text{ km}) \gg \lambda_{Det}(\sim 1 \text{ m})$$

$$\delta B_z = B_0 h_{GW} \sin^2 \theta \cos 2\psi$$

Plus polarization antenna pattern

Color:  $|\delta \mathbf{B}|/B_0$ , arrows: direction and relative magnitude

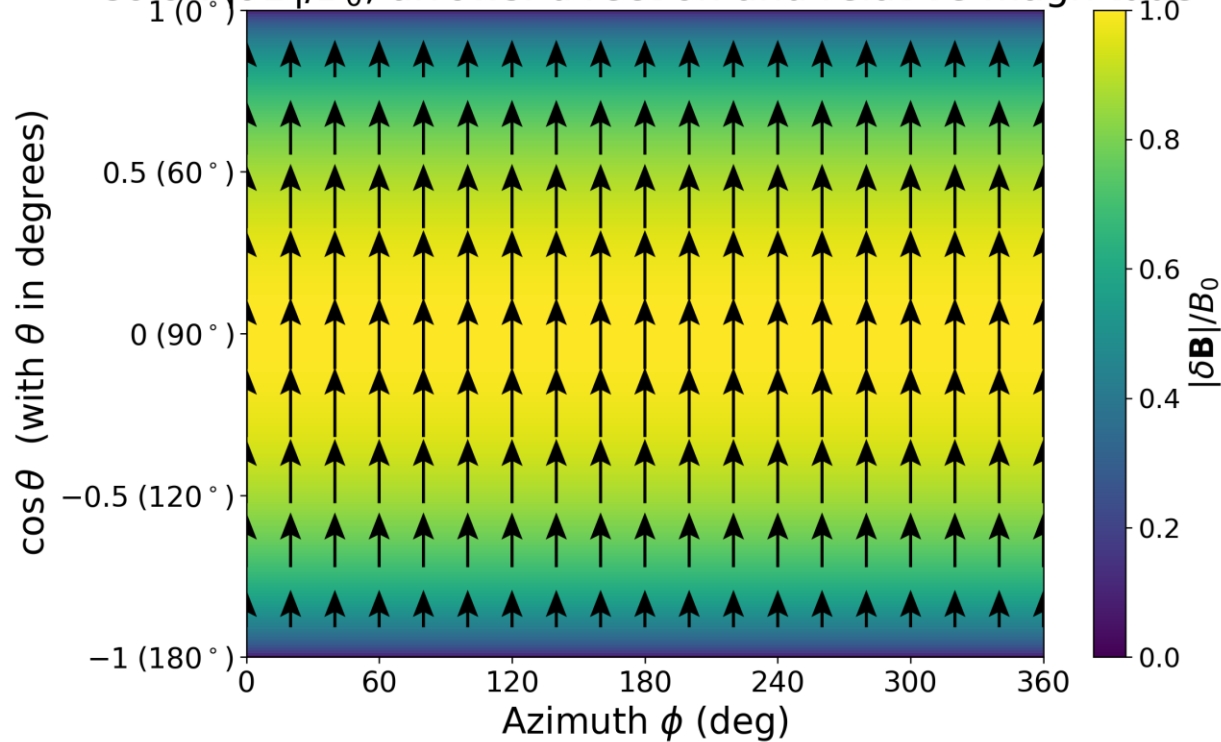

Cross polarization antenna pattern

Color:  $|\delta \mathbf{B}|/B_0$ , arrows: direction and relative magnitude

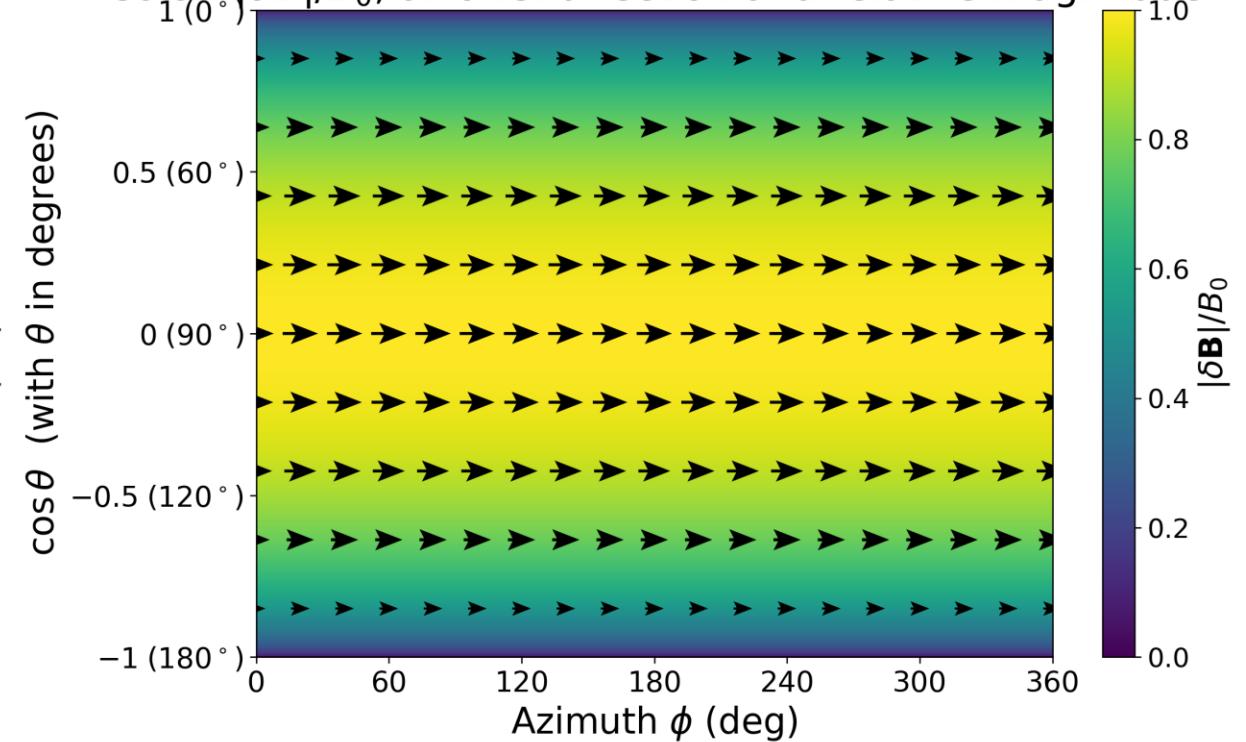

# SQUID Readout Chain

## SQUID Readout Chain for AURIGA Experiment

**P. Falferi, M. Bonaldi, A. Vinante, R. Mezzena, G. A. Prodi, S. Vitale, M. Cerdonio, "100 hbar SQUID amplifiers for the ultracryogenic gravitational wave detectors," Moriond Workshop presentation, 2003.**

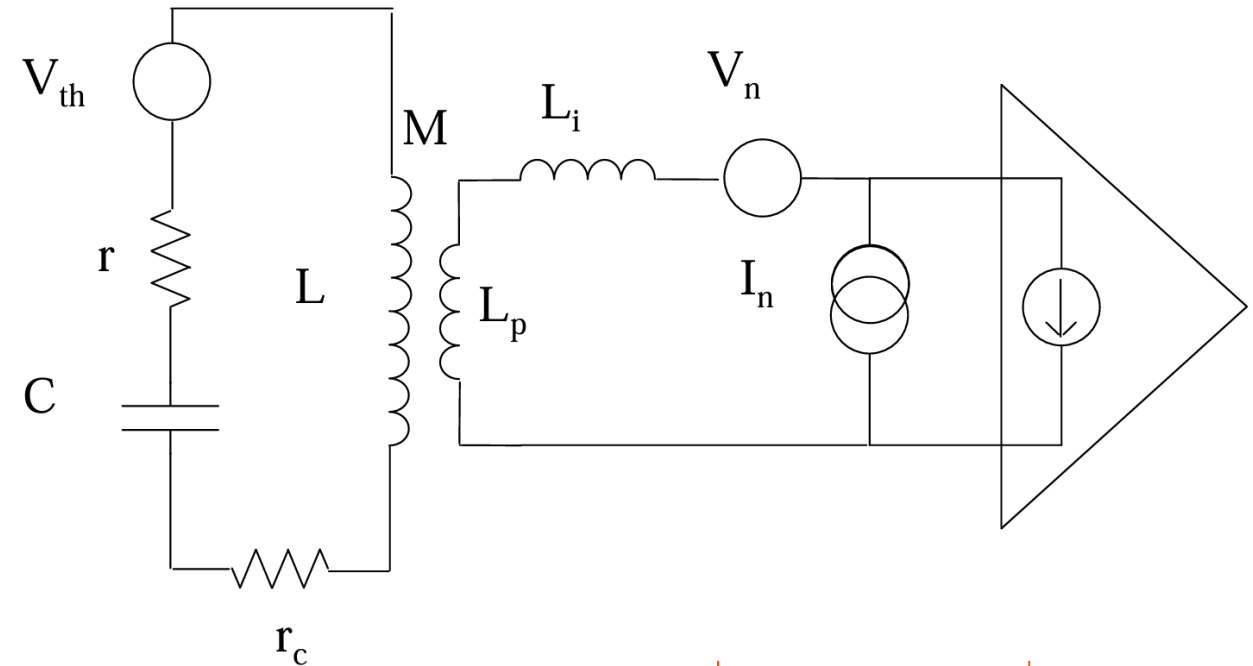
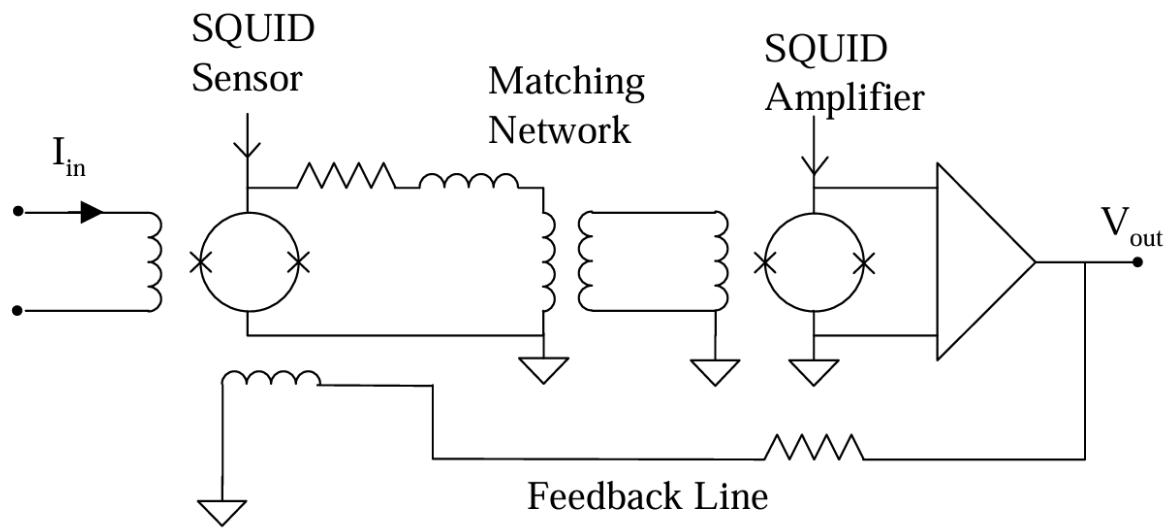

# SQUID Readout Chain

## SQUID Readout Chain for AURIGA Experiment

L. Baggio, M. Bignotto, M. Bonaldi, M. Cerdonio, L. Conti, **P. Falferi**, N. Liguori, A. Marin, R. Mezzena, **A. Ortolan**, S. Poggi, G. A. Prodi, F. Salemi, G. Soranzo, L. Taffarello, G. Vedovato, A. Vinante, S. Vitale, and J. P. Zendri, "3-mode detection for widening the bandwidth of resonant gravitational wave detectors," *Physical Review Letters* **94**, 241101 (2005).

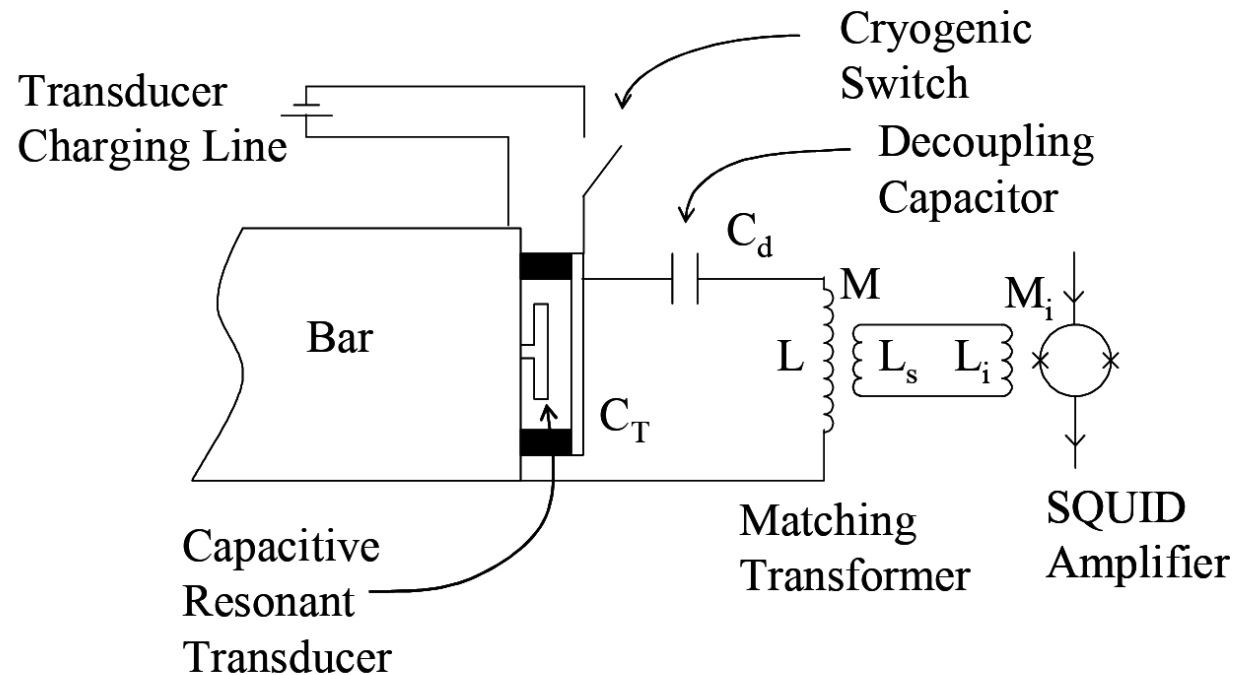

# SQUID Readout Chain

## SQUID Readout Chain for AURIGA Experiment

L. Baggio, M. Bignotto, M. Bonaldi, M. Cerdonio, L. Conti, **P. Falferi**, N. Liguori, A. Marin, R. Mezzena, **A. Ortolan**, S. Poggi, G. A. Prodi, F. Salemi, G. Soranzo, L. Taffarello, G. Vedovato, A. Vinante, S. Vitale, and J. P. Zendri, "3-mode detection for widening the bandwidth of resonant gravitational wave detectors," *Physical Review Letters* **94**, 241101 (2005).

### Mechanical Resonant of Bar + Transducer Resonance + Electro Magnetic Mode

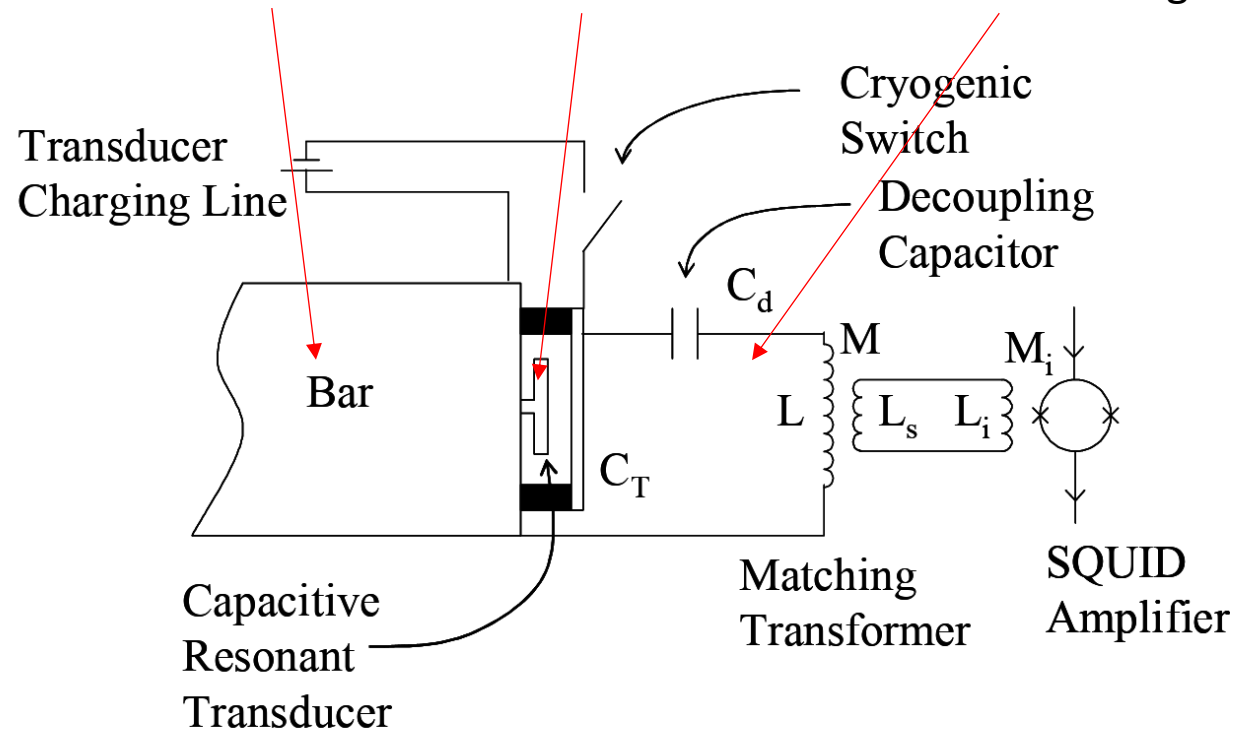

# SQUID Readout Chain

## SQUID Readout Chain for AURIGA Experiment

L. Baggio, M. Bignotto, M. Bonaldi, M. Cerdonio, L. Conti, **P. Falferi**, N. Liguori, A. Marin, R. Mezzena, **A. Ortolan**, S. Poggi, G. A. Prodi, F. Salemi, G. Soranzo, L. Taffarello, G. Vedovato, A. Vinante, S. Vitale, and J. P. Zendri, “3-mode detection for widening the bandwidth of resonant gravitational wave detectors,” *Physical Review Letters* **94**, 241101 (2005).

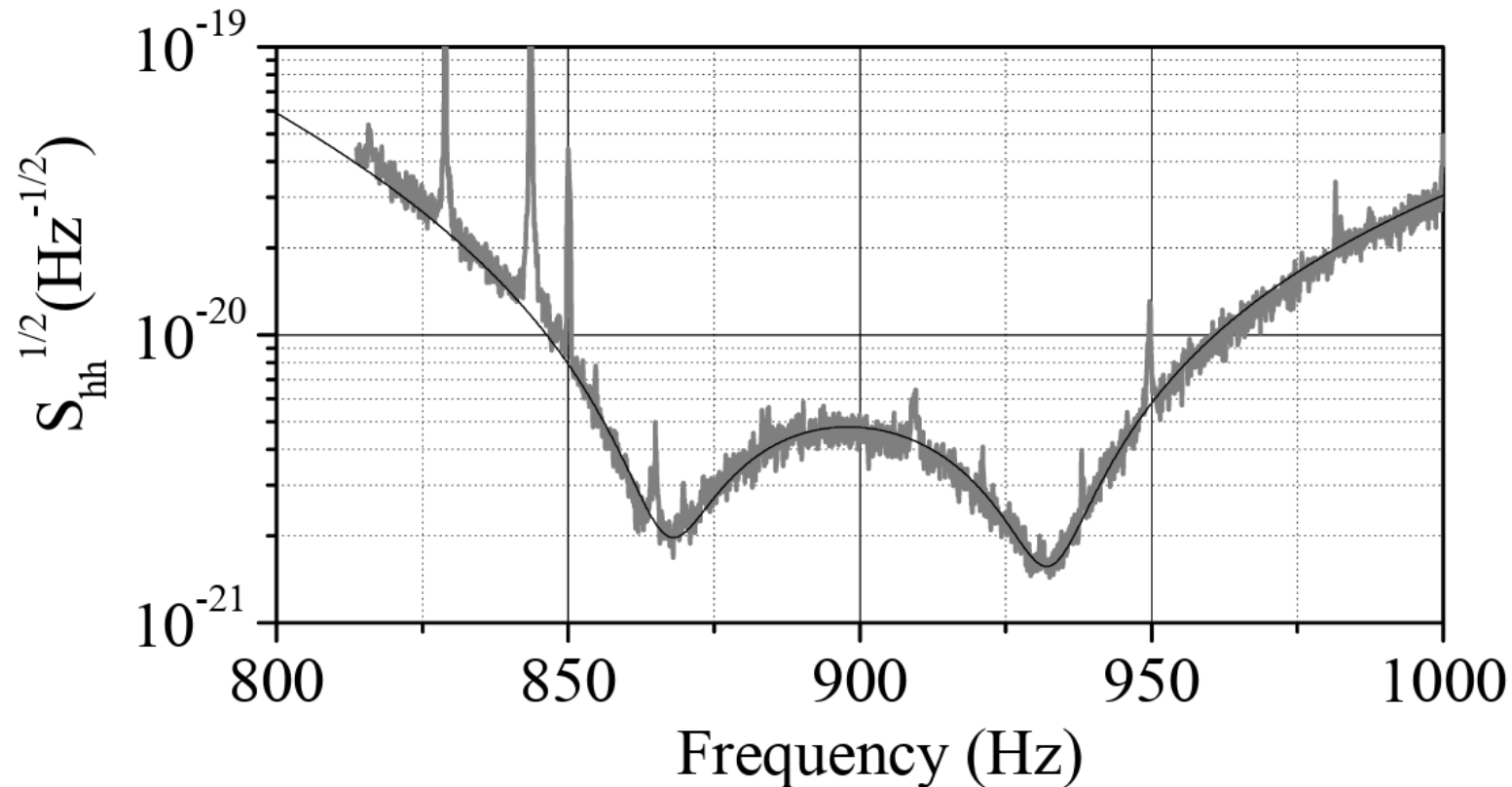

# SQUID Readout Chain

## SQUID Readout Chain for LC Circuit Detection

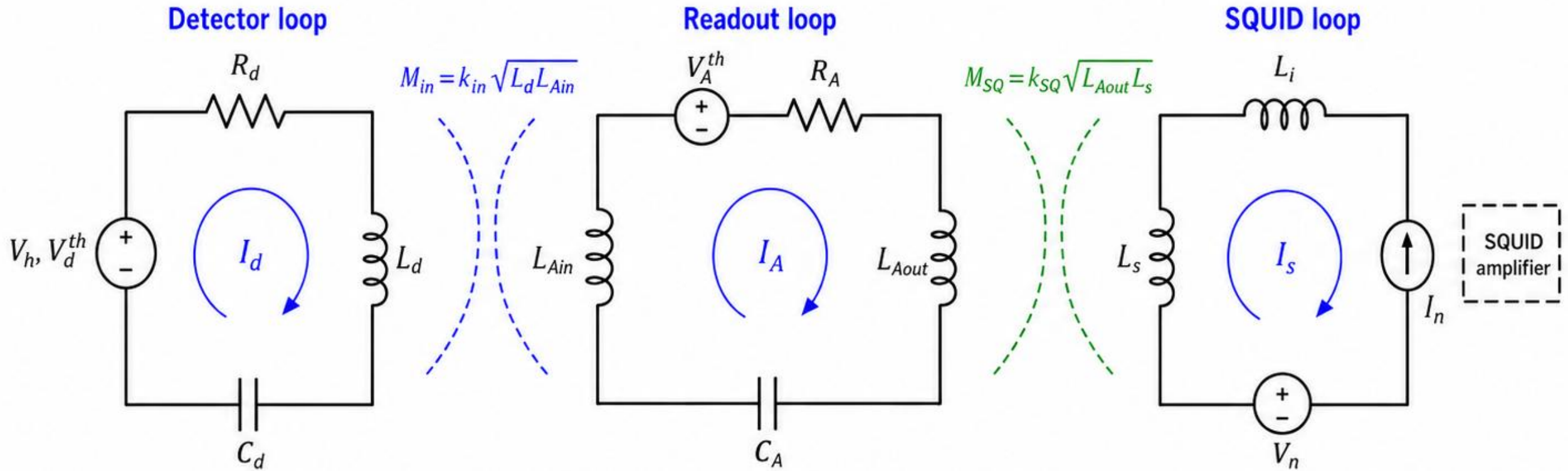

# SQUID Readout Chain

## SQUID Readout Chain for LC Circuit Detection

Signal source:

$$V_h = i\omega NABh$$

Detector impedance:

$$Z_d(\omega) = R_d + i\omega L_d + \frac{1}{i\omega C_d}$$

Readout impedance:

$$Z_A(\omega) = R_A + i\omega (L_{Ain} + L_{Aout}) + \frac{1}{i\omega C_A}$$

SQUID-loop impedance:

$$Z_s(\omega) = R_s + i\omega (L_s + L_i)$$

Measured SQUID flux:

$$\Phi_{meas} = L_i (I_s + I_n)$$

Loop-current vector:

$$I = (I_d, I_A, I_s)^T$$

Loop equations:

$$\begin{pmatrix} Z_d & i\omega M_{in} & 0 \\ i\omega M_{in} & Z_A & i\omega M_{SQ} \\ 0 & i\omega M_{SQ} & Z_s \end{pmatrix} \begin{pmatrix} I_d \\ I_A \\ I_s \end{pmatrix} = \begin{pmatrix} V_h + V_d^{th} \\ V_A^{th} \\ V_n \end{pmatrix}$$

Strain-noise model:

$$\mathcal{D}_3(\omega) = Z_s(\omega) [Z_d(\omega)Z_A(\omega) + \omega^2 M_{in}^2] + \omega^2 M_{SQ}^2 Z_d(\omega)$$

$$S_{hh} = S_d + S_A + S_{ba} + S_{imp}$$

$$S_d = \frac{4k_B T_d R_d}{\omega^2 (NAB)^2}$$

$$S_A = \frac{|Z_d|^2 4k_B T_A R_A}{\omega^4 (NAB)^2 M_{in}^2}$$

$$S_{ba} = \frac{|Z_d Z_A + \omega^2 M_{in}^2|^2 S_{V_n}}{\omega^6 (NAB)^2 M_{in}^2 M_{SQ}^2}$$

$$S_{imp} = \frac{|\mathcal{D}_3|^2 S_{I_n}}{\omega^6 (NAB)^2 M_{in}^2 M_{SQ}^2}$$

# GW Detection by LC Circuit in a High B Field

## SQUID Readout Chain for LC Circuit Detection

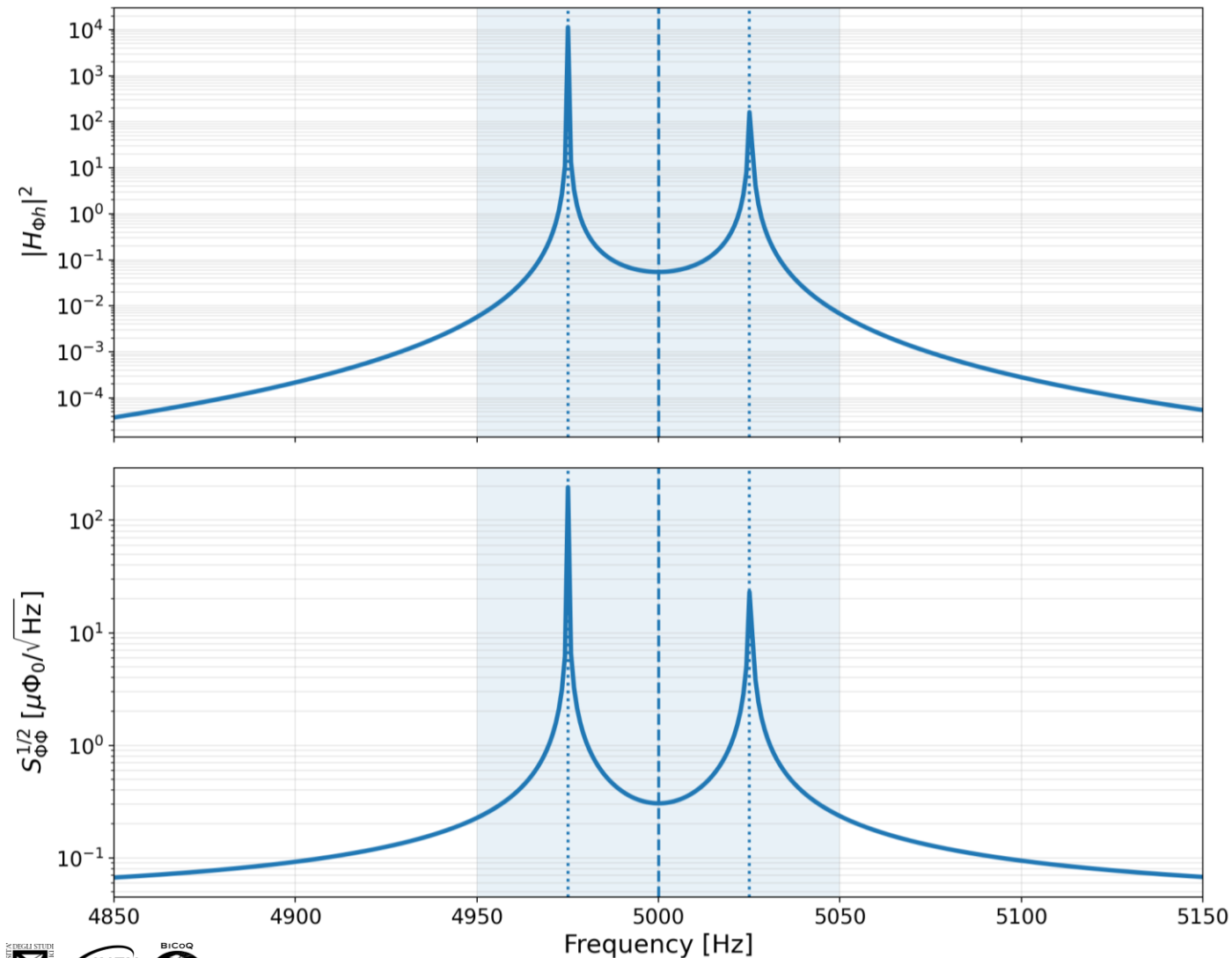

$$S_{\Phi\Phi}^{\text{out}}(\omega) = |H_{\Phi h}(\omega)|^2 S_{hh}^{\text{total}}(\omega).$$

# GW Detection by LC Circuit in a High B Field

## SQUID Readout Chain for LC Circuit Detection

$$S_{\Phi\Phi}^{\text{out}}(\omega) = |H_{\Phi h}(\omega)|^2 S_{hh}^{\text{total}}(\omega).$$

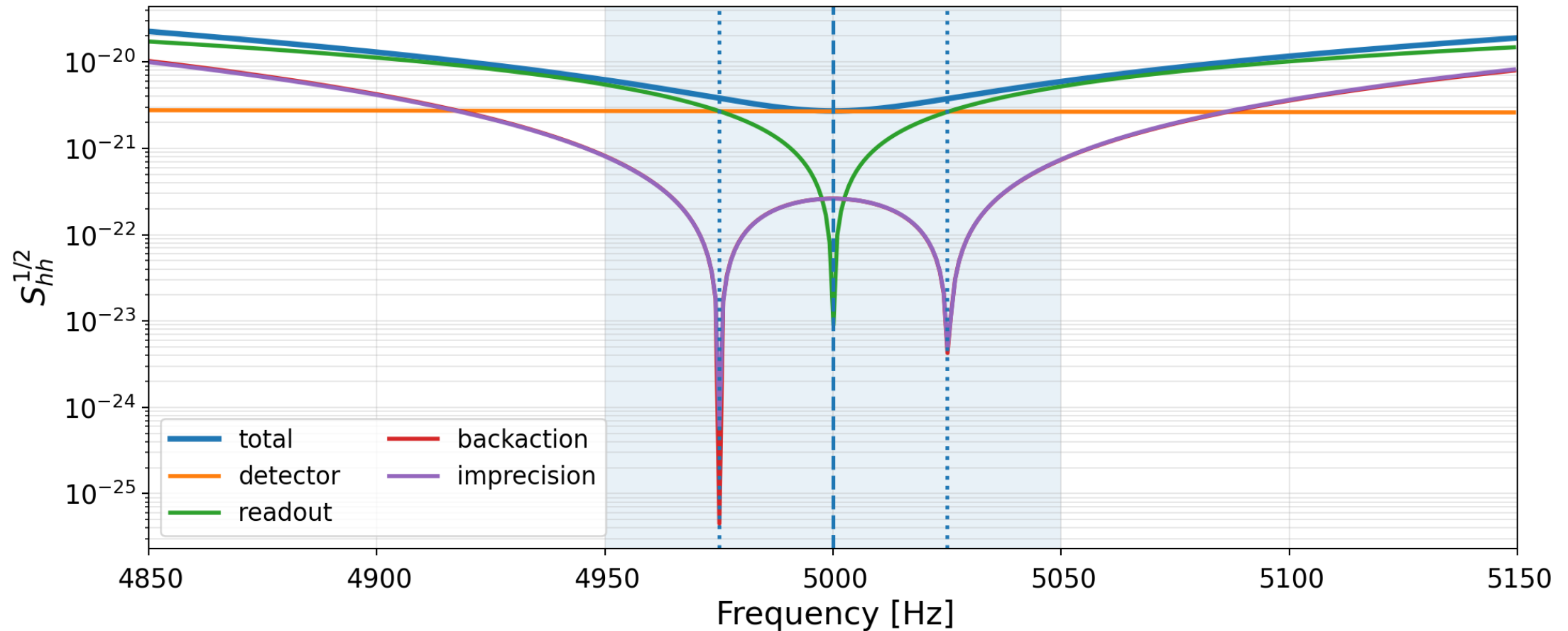

# State of Art Technologies

## Superconducting LC Circuit Development at QUAX

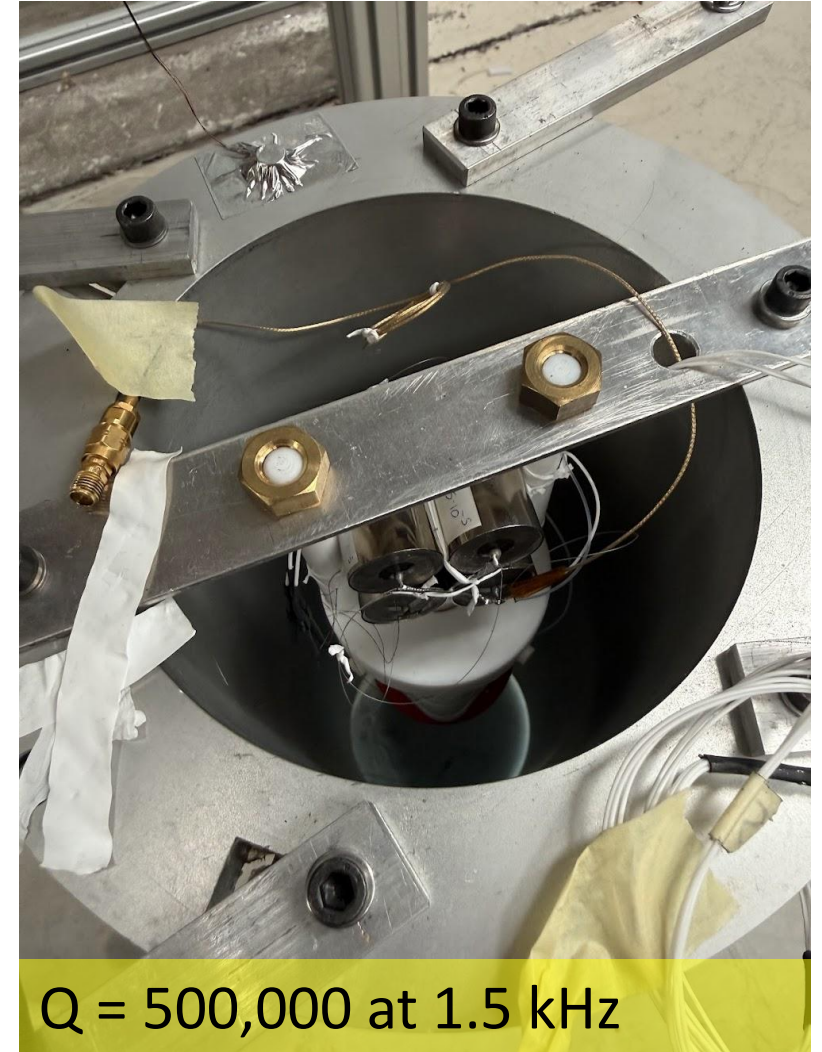
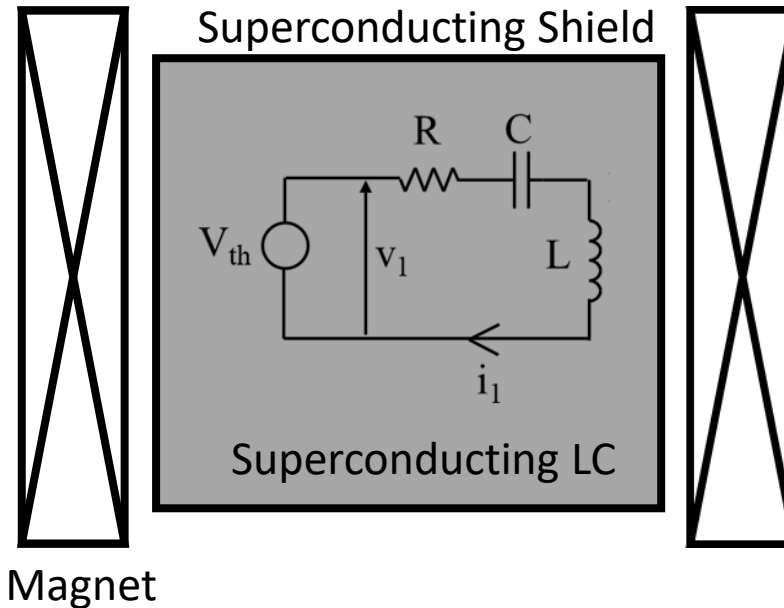

Q = 500,000 at 1.5 kHz

# State of Art Technologies

## High-Temperature Superconducting LC Circuit

Christoph Utschick, *Superconducting Wireless Power Transfer at High Power Densities for Industrial Applications and Fast Battery Charging*, PhD dissertation, Technical University of Munich, 2021.

$$Q_i \approx 2\pi \times \frac{\text{stored energy}}{\text{energy loss per cycle}} = 2\pi \times \frac{L_i I_{\text{rms}}^2}{R_{\text{AC},i} I_{\text{rms}}^2 / f_r} = \frac{\omega_r L_i}{R_{\text{AC},i}}$$

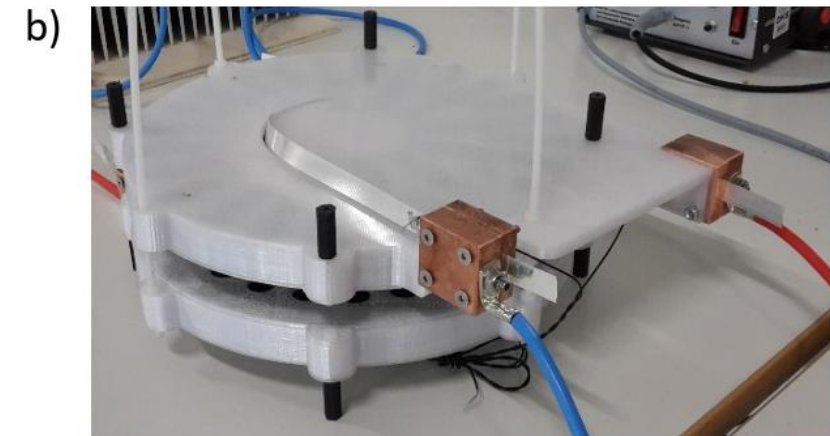
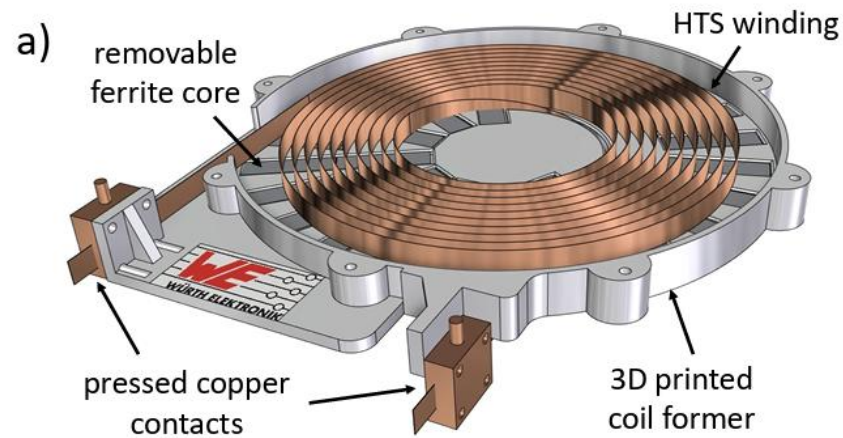
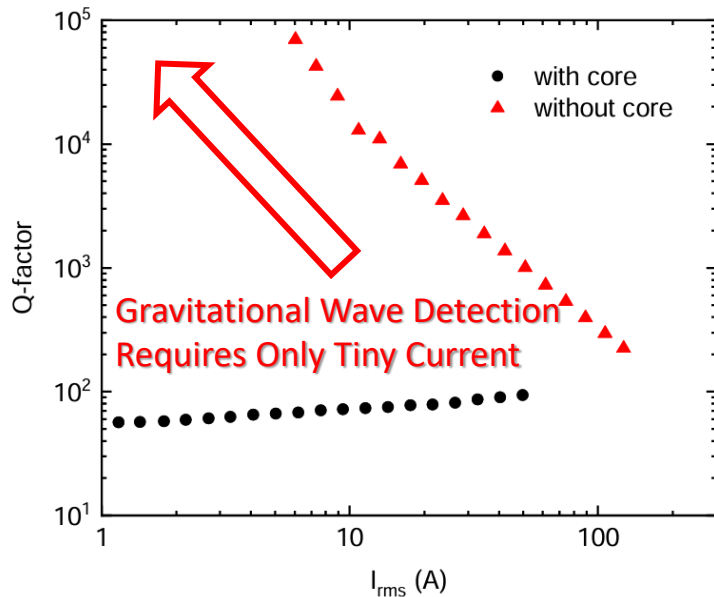

# State of Art Technologies

## High-Temperature Superconducting Tape Junction Resistance

Y. Takeda, G. Nishijima, and H. Kitaguchi, "Resistance and Voltage–Current Characteristics of REBCO Superconducting Joint," / *IEEE Transactions on Applied Superconductivity*, vol. 35, no. 5, article no. 6604106, pp. 1–6, 2025, doi: 10.1109/TASC.2025.3550140.

Junction resistance  $10^{-15}$  Ohm is achievable for the small current regime

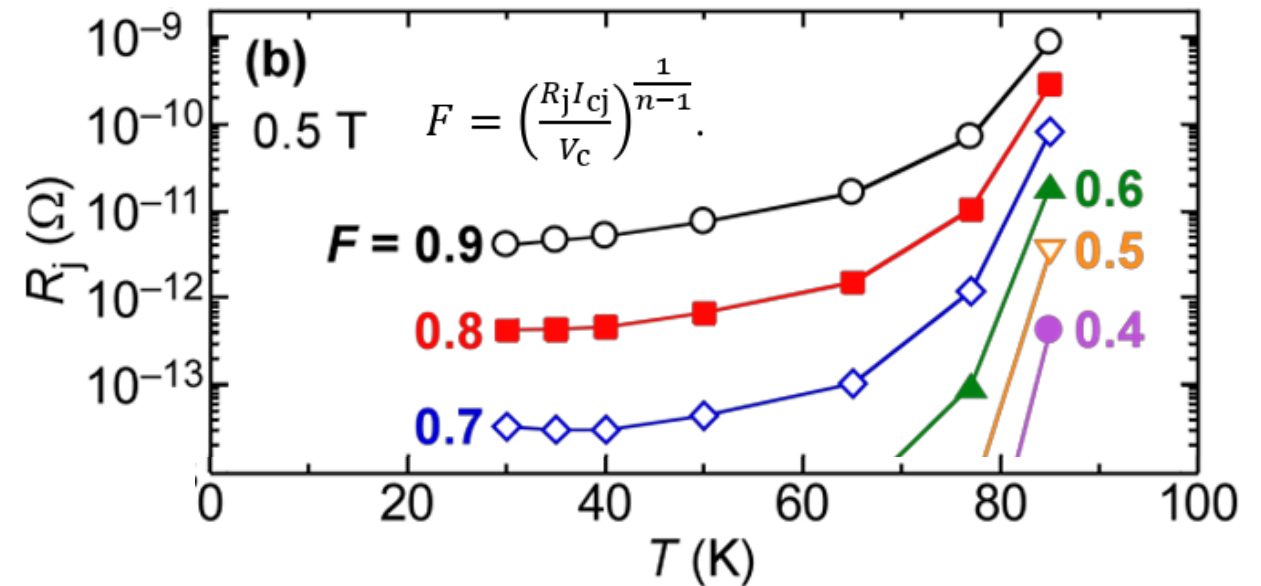
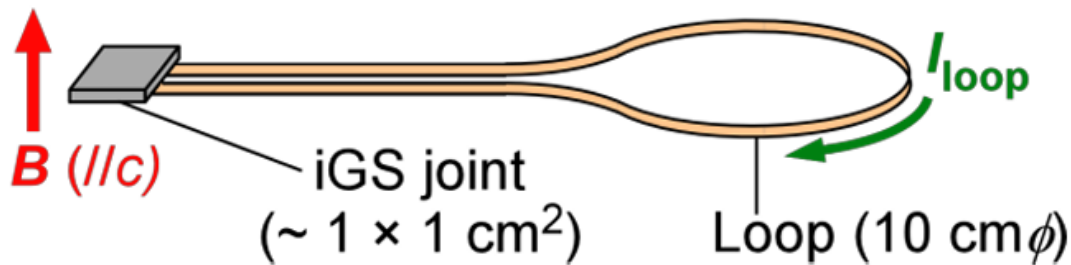

# State of Art Technologies

## QUAX-BLU Cryogenics

### Stable 10 mK Operation

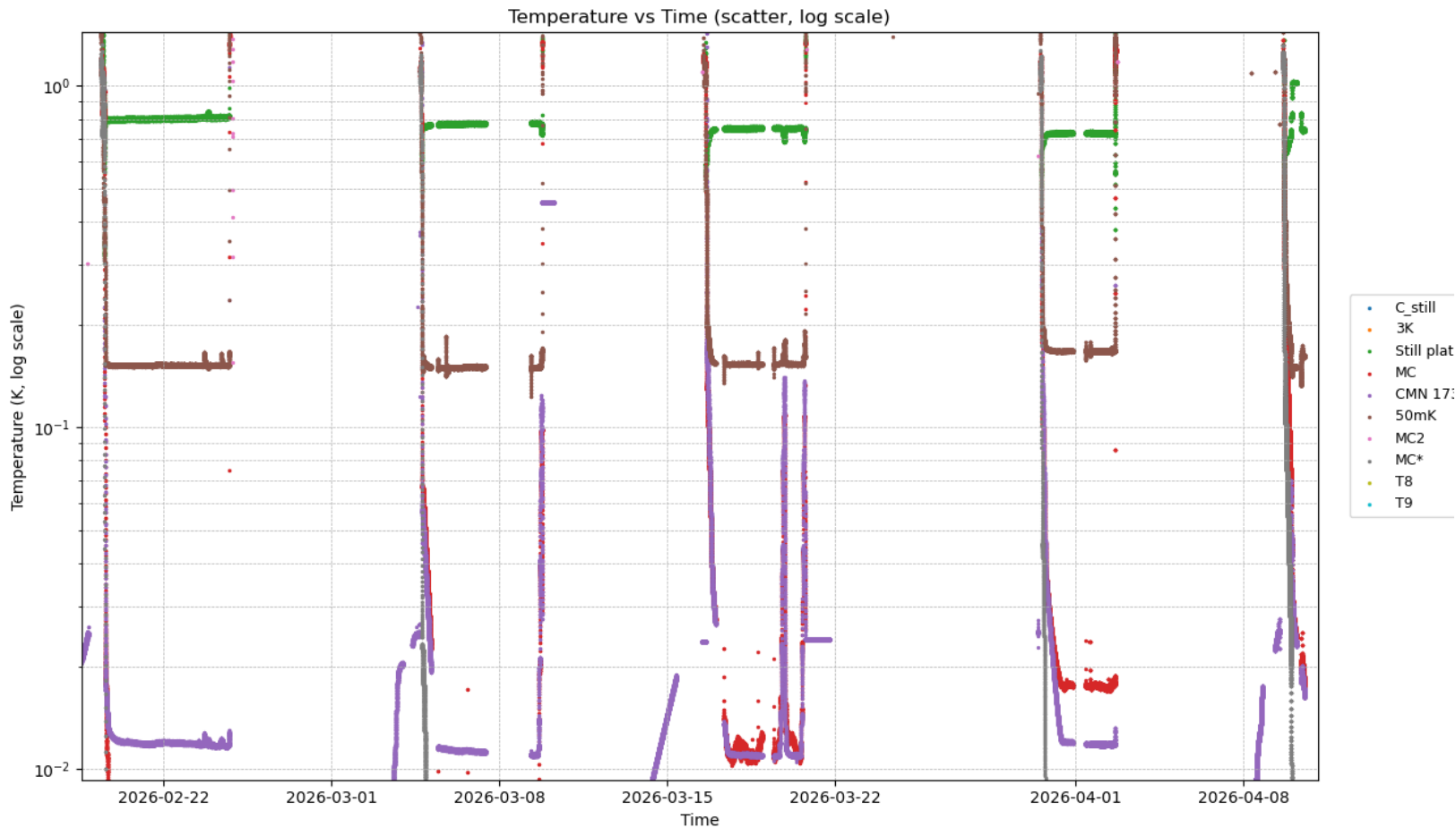

### QUAX-BLU

10 mK Base Temperature

9 T Magnet

Single Microwave Photon Counter

Axion/Ferromagnetic Haloscope



# State of Art Technologies

## QUAX-RED 14 T Magnet

10 cm Bore Size 14 T Magnet



QUAX-RED
Sub-100 mK
14 T Magnet
Quantum-Limited Noise Amplifier
Axion Haloscope, Dark Photon





# Tuning & Optimization of Detector Circuit

## 3 Mode Detection for LC Circuit Detector

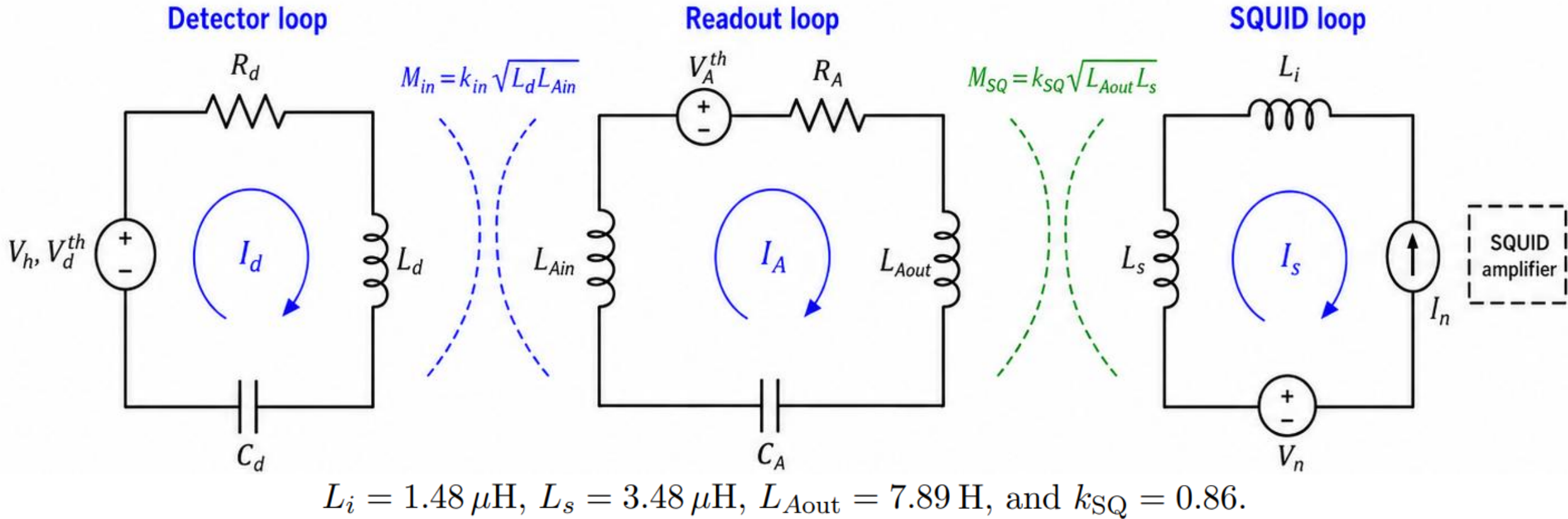

L. Baggio, M. Bignotto, M. Bonaldi, M. Cerdonio, L. Conti, **P. Falferi**, N. Liguori, A. Marin, R. Mezzena, **A. Ortolan**, S. Poggi, G. A. Prodi, F. Salemi, G. Soranzo, L. Taffarello, G. Vedovato, A. Vinante, S. Vitale, and J. P. Zendri, "3-mode detection for widening the bandwidth of resonant gravitational wave detectors," *Physical Review Letters* **94**, 241101 (2005).

# Tuning & Optimization of Detector Circuit

## 3 Mode Detection for LC Circuit Detector

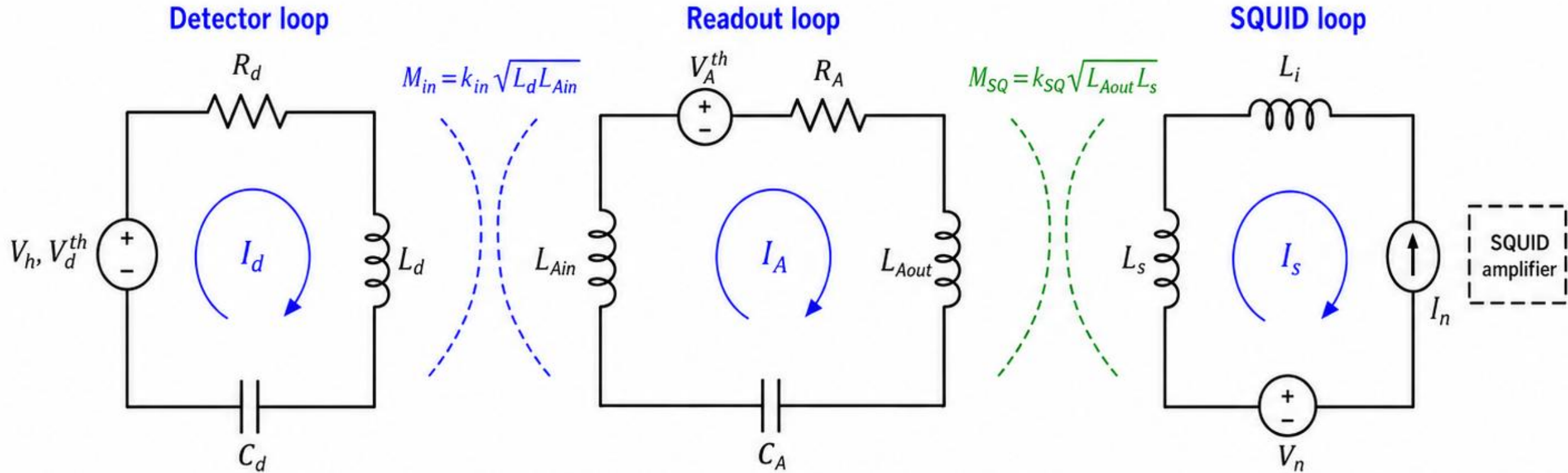

Standard Quantum Limit of SQUID Noise

$$\sqrt{S_{vv} S_{ii}} = \hbar, \quad S_{vi} = 0,$$

# Tuning & Optimization of Detector Circuit

## 3 Mode Detection for LC Circuit Detector

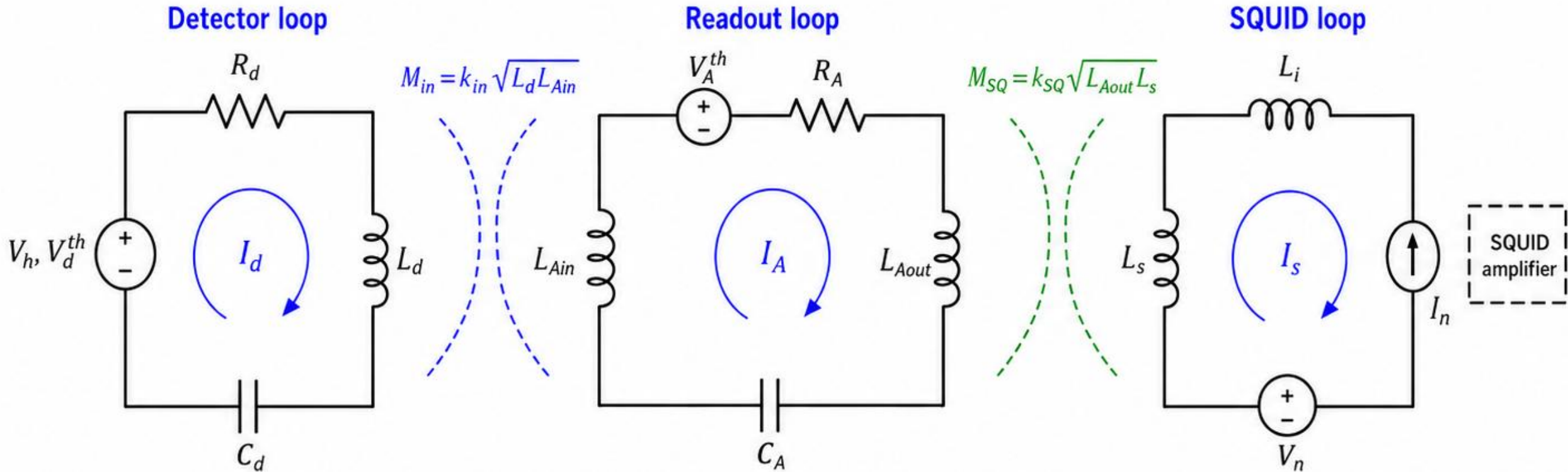

14 T Magnet & Coil Assumption

$D = 10 \text{ cm}, B = 14 \text{ T}, T = 10 \text{ mK}, N = 1,000$

# Tuning & Optimization of Detector Circuit

## Frequency Adjustment with $Q \sim 10^7$ Resonators

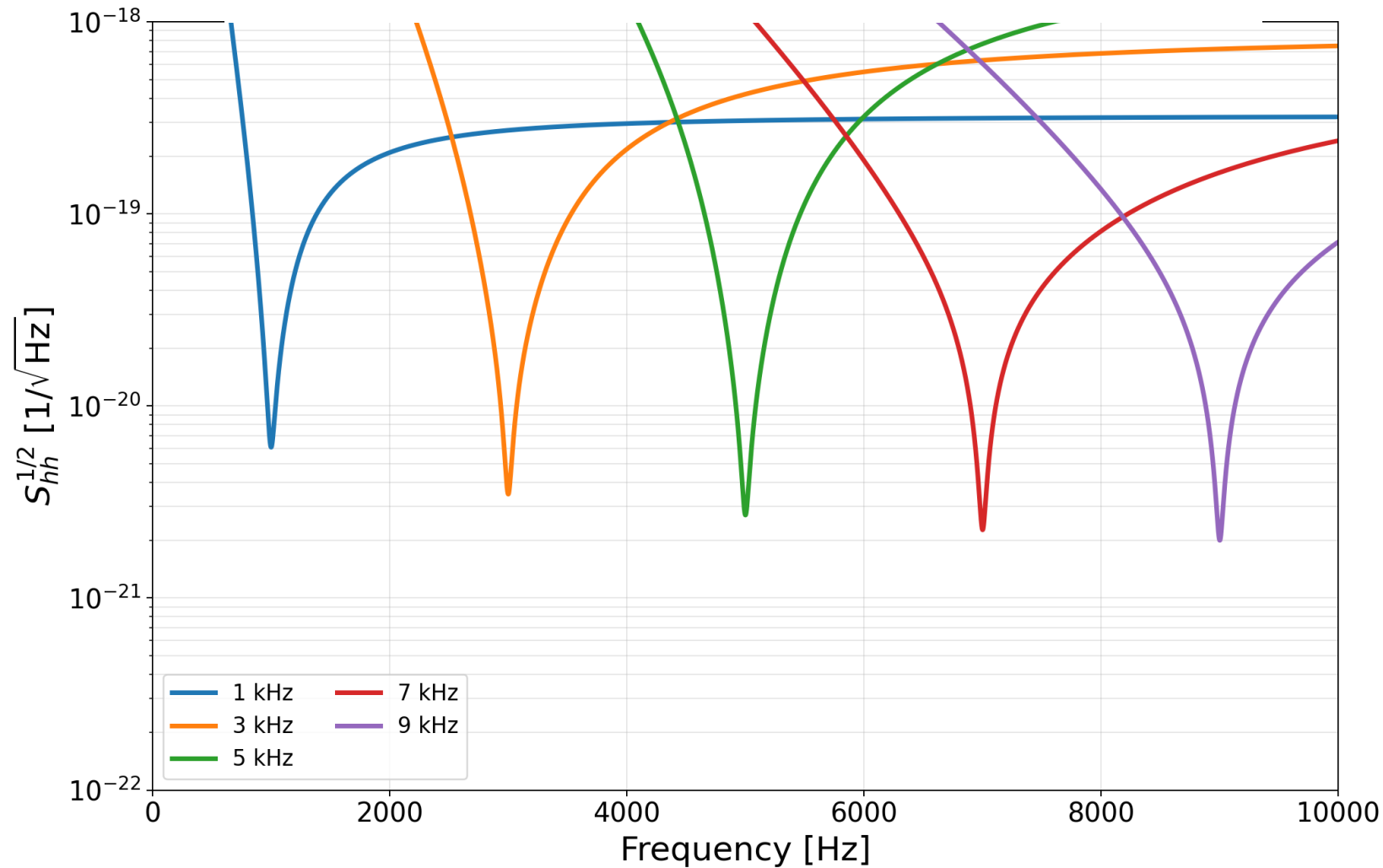

# Tuning & Optimization of Detector Circuit

## Sub- $10^{-21}$ Strain Sensitivity with Quality Factor Improvement

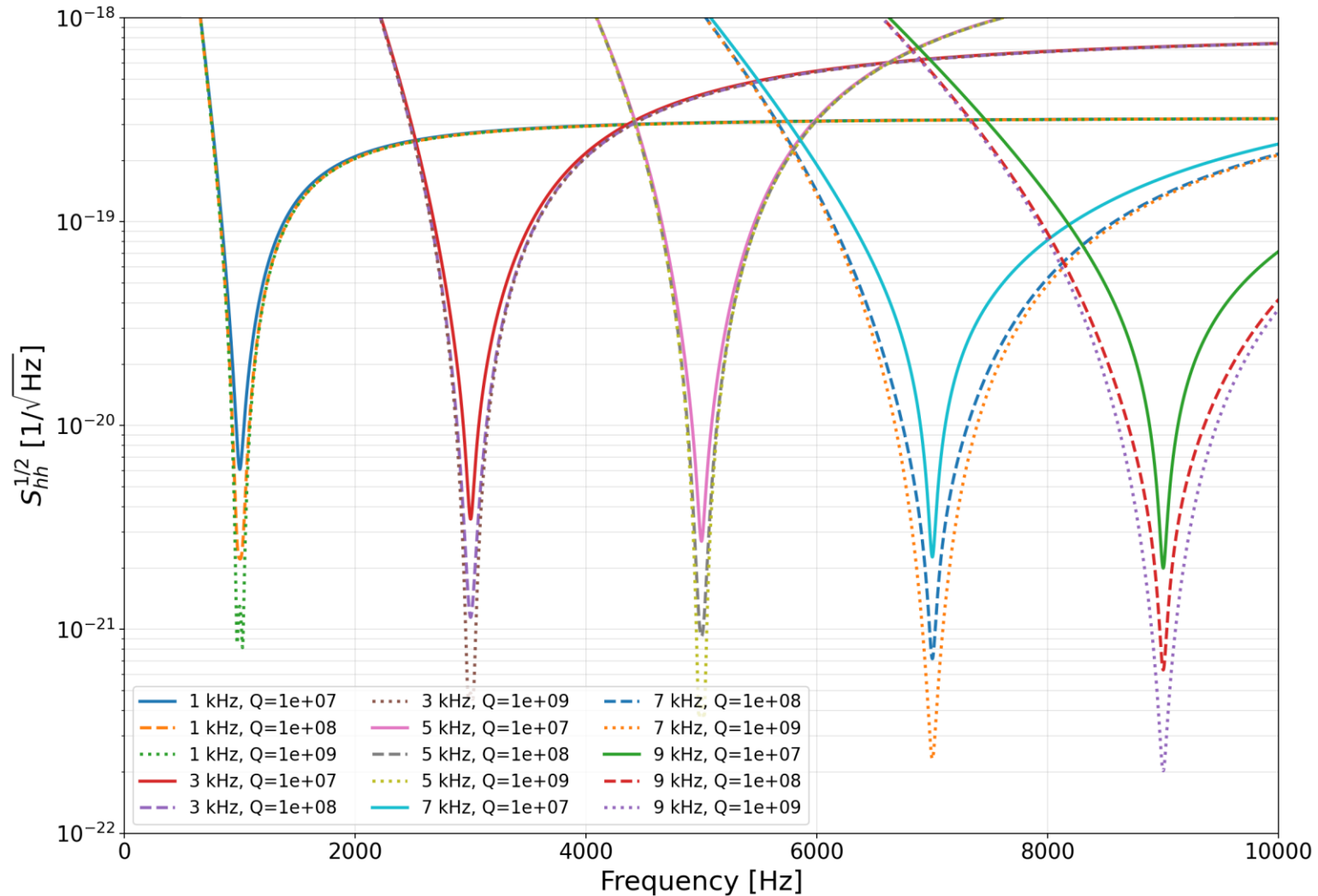

# Tuning & Optimization of Detector Circuit

## Sub- $10^{-21}$ Strain Sensitivity with Quality Factor Improvement

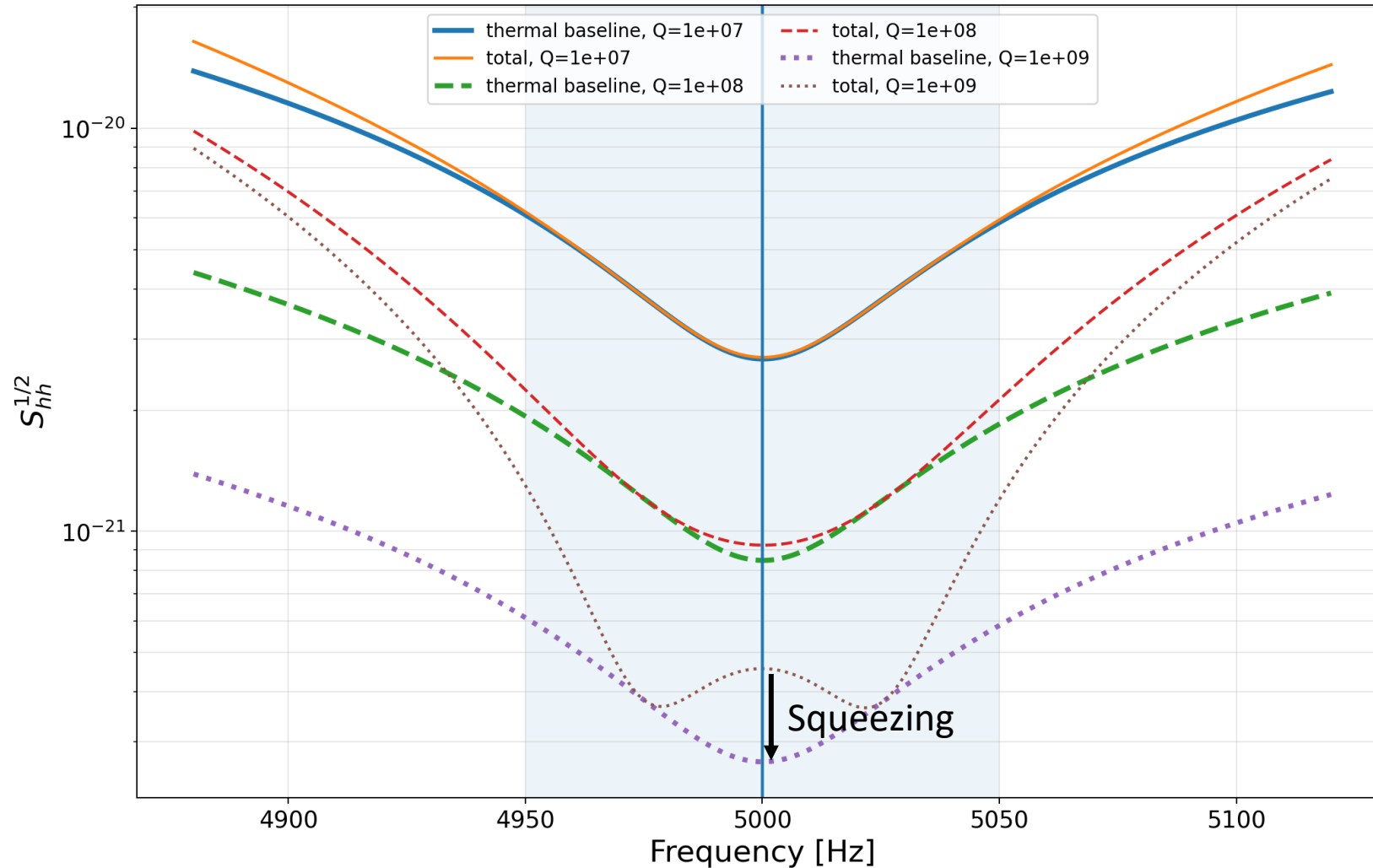

# Summary

## Tabletop Efforts Toward kHz Gravitational Wave Detection at QUAX

- Large-scale interferometers lose strain sensitivity in the kHz regime as shot noise becomes dominant, and standard LIGO strain data are sampled at 16 kHz, corresponding to an effective Nyquist limit near 8 kHz.
- The kHz band remains scientifically attractive, especially for gravitational waves from binary neutron-star mergers and post-merger remnants.
- A superconducting LC resonator immersed in a strong magnetic field could detect gravitational-wave-induced magnetic-field oscillations in a compact tabletop setup. This approach can build on INFN-LNL's AURIGA experience with SQUID readout.
- By combining state-of-the-art superconducting resonators, HTS technology, 10 mK cryogenics, and high-field magnets up to 14 T, QUAX has the key technological basis for a feasible 100Hz-band detector targeting sub- $10^{-21}$  strain sensitivity.