

The DELight Experiment

Overview and Perspectives



1st BiCoQ Conference: from gravity to particles
June 16, 2026

Anna Bertolini
Heidelberg University
on behalf of the DELight Collaboration

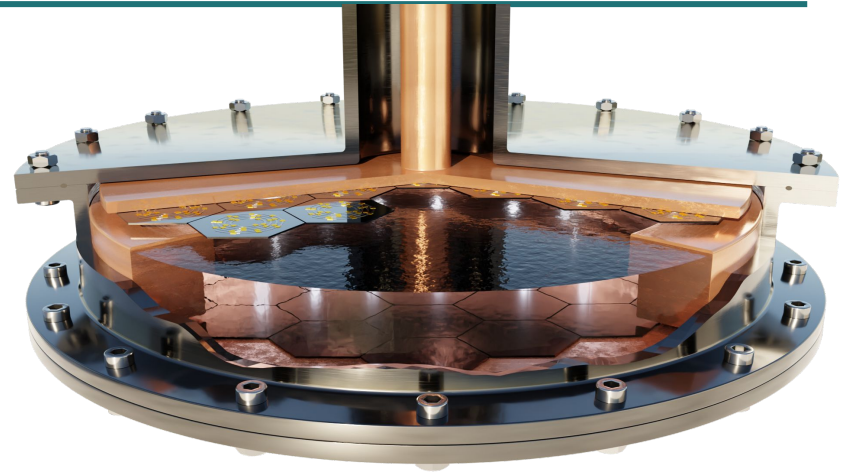

The Collaboration



- >20 scientists
- Four institutions
- Designing future **Direct search Experiment for LIGHT dark matter**



Goal of the DELight Experiment



- Goal: probe **Light Dark Matter**
→ DM-nucleon interaction
- Use superfluid ^4He as target material
- Light nuclei → ideal for LDM search
- Measurement of phonons
- No stress-related Low-Energy-Excess in LHe

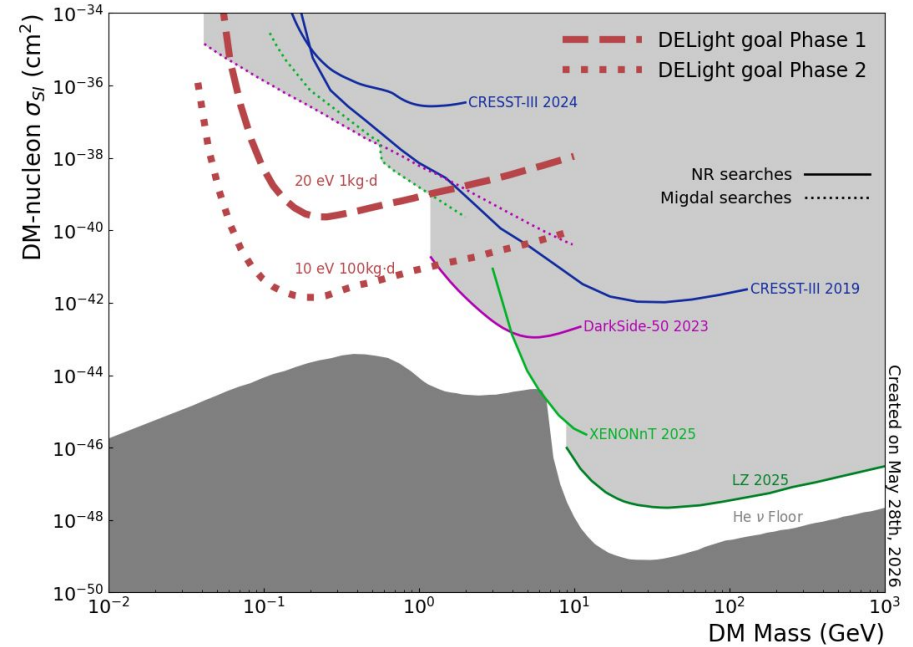
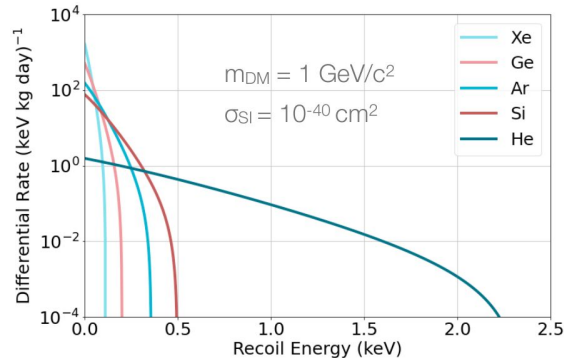

Created on May 28th, 2026

Superfluid ^4He as Target Material

- No intrinsic long-lived backgrounds
- Contaminants freeze-out
- Multiple signals

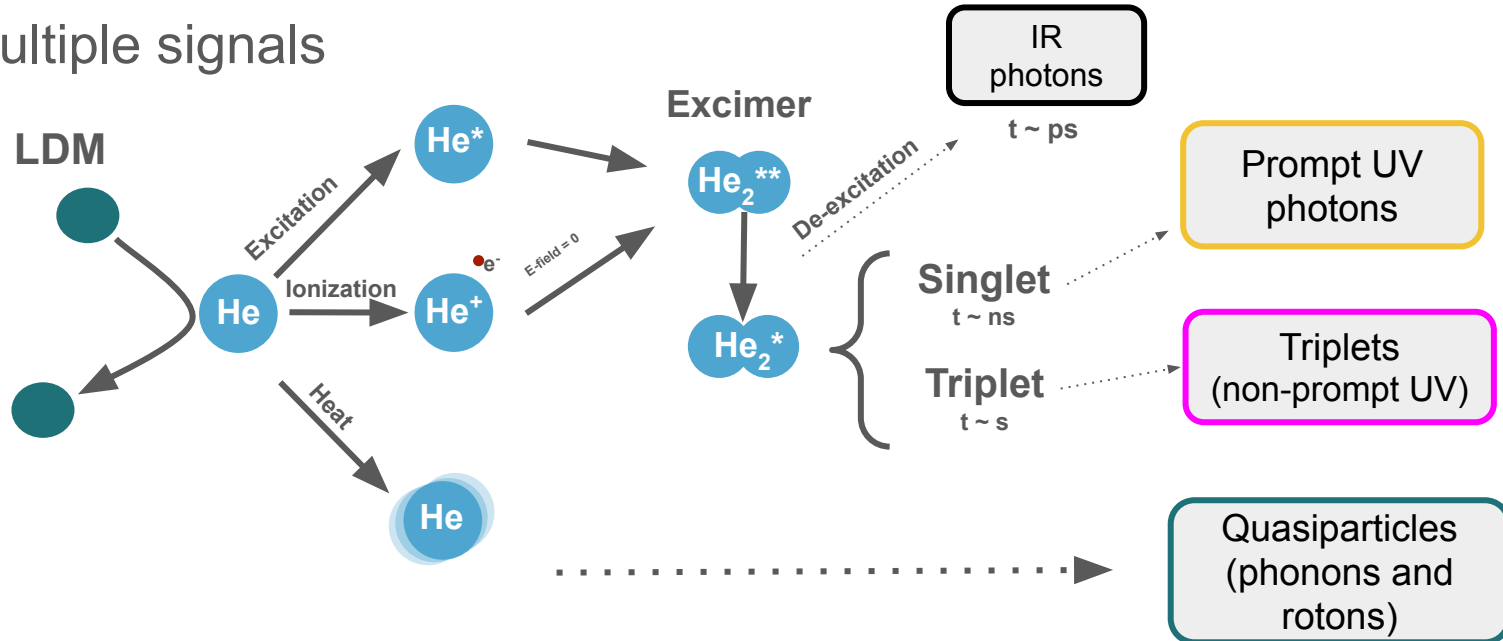

Superfluid ^4He as Target Material

- No intrinsic long-lived backgrounds
- Contaminants freeze-out
- Multiple signals
→ **potential ER/NR discrimination**

Phys. Rev. D 111, 032013

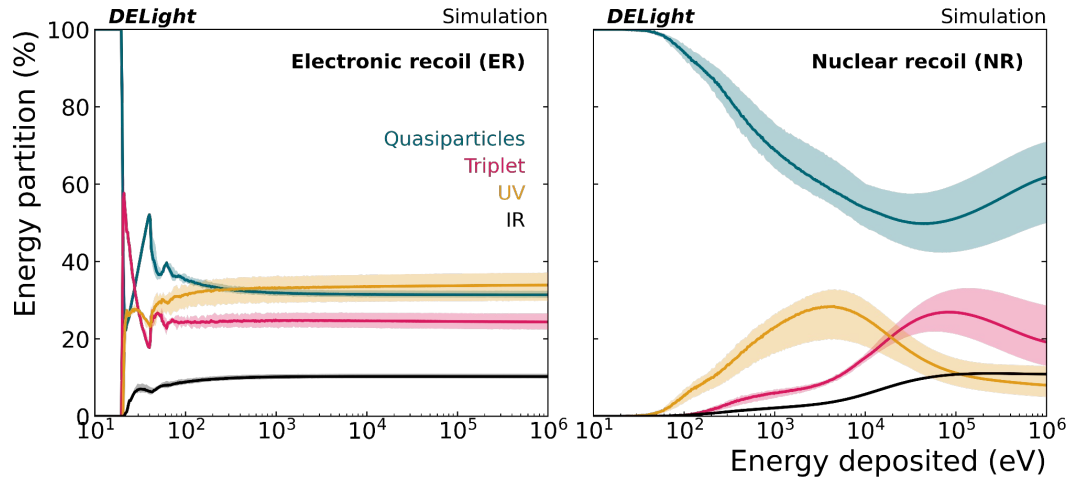

IR photons

Prompt UV photons

Triplets (non-prompt UV)

Quasiparticles (phonons and rotons)

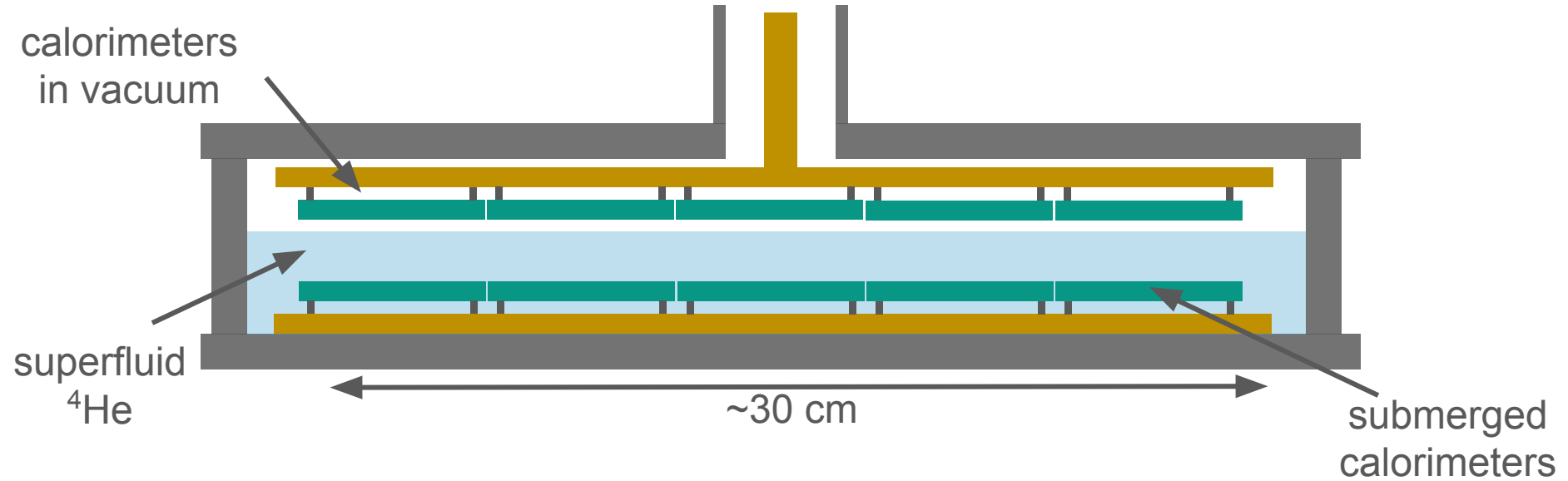

- Cell filled partially (~1 liter) with superfluid ^4He @20 mK
- Calorimeters (sensor arrays) positioned in liquid and in vacuum

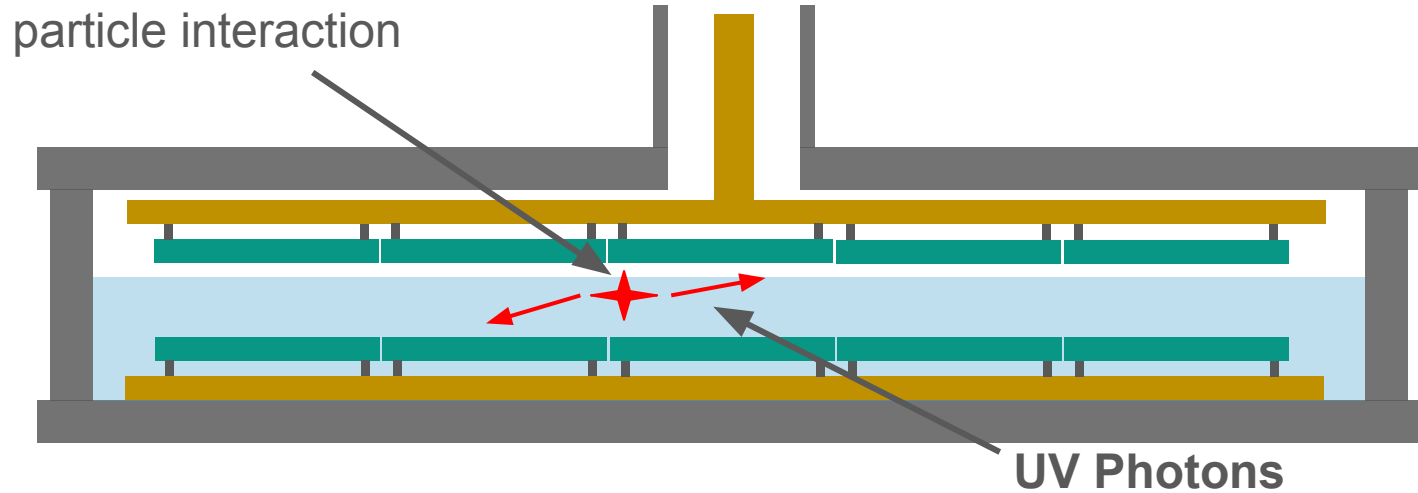

- Singlet → UV photons
- First excited state in ^4He at $\sim 20\text{eV}$ → Liquid transparent to UV photons
- Detection in both sensor arrays

particle interaction

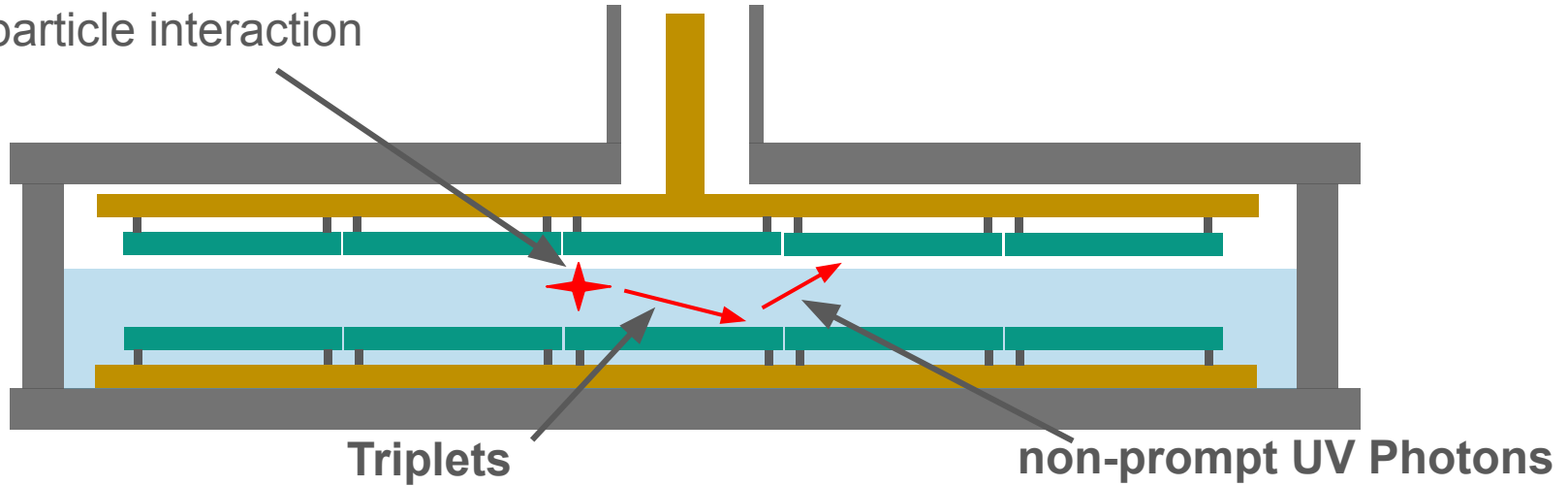

- Triplets lifetime 13s → de-excite when reaching a surface
- UV photons delayed at calorimeter

particle interaction

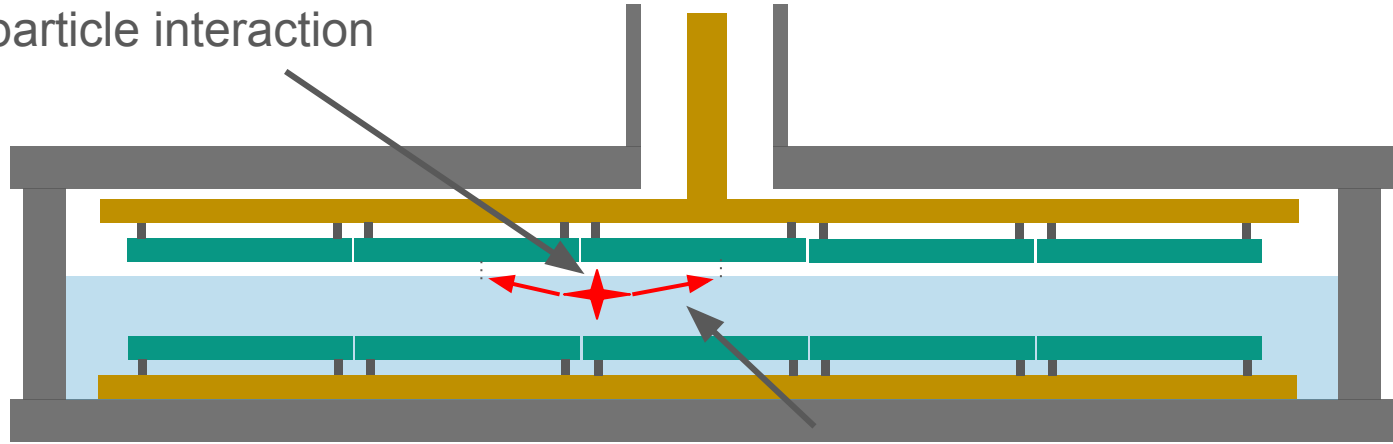

Phonons/Rotons

- Quasiparticles propagate ballistically
- Evaporate He atoms at liquid surface → quantum evaporation

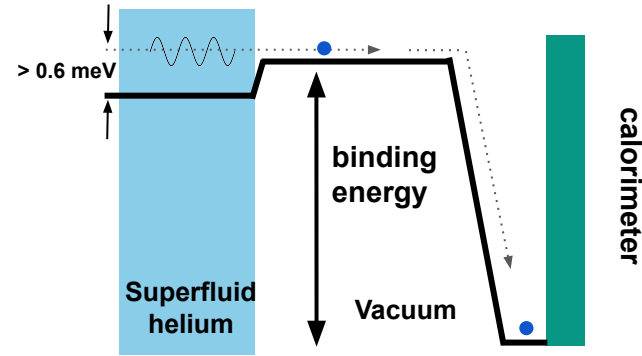
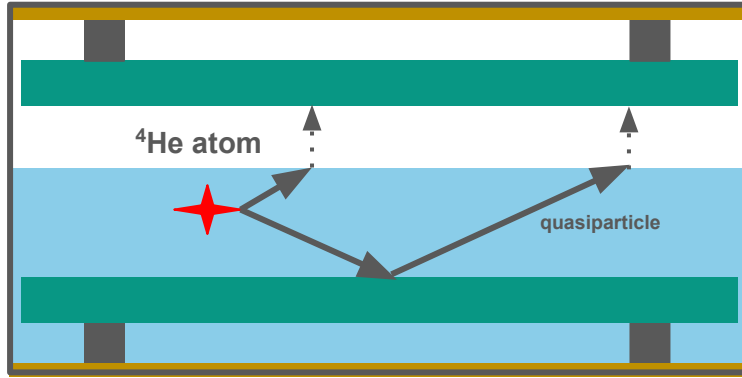

- Released He atoms condense on the sensor in vacuum
- Adsorption energy onto sapphire wafer $\sim 20\times$ binding energy
→ effective **signal amplification**
- Sensor in vacuum must be free from He film → Film burner

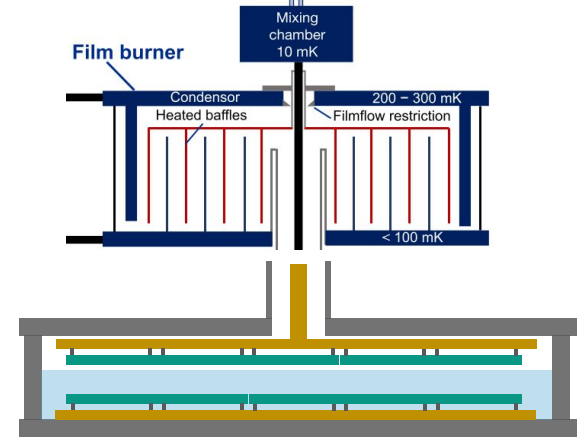
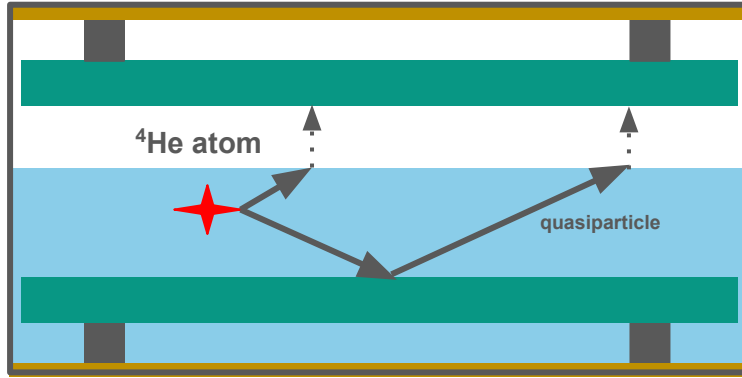

- Released He atoms condense on the sensor in vacuum
- Adsorption energy onto sapphire wafer $\sim 20\times$ binding energy
→ effective **signal amplification**
- Sensor in vacuum must be free from He film → Film burner

Calorimeters: LAMCALs

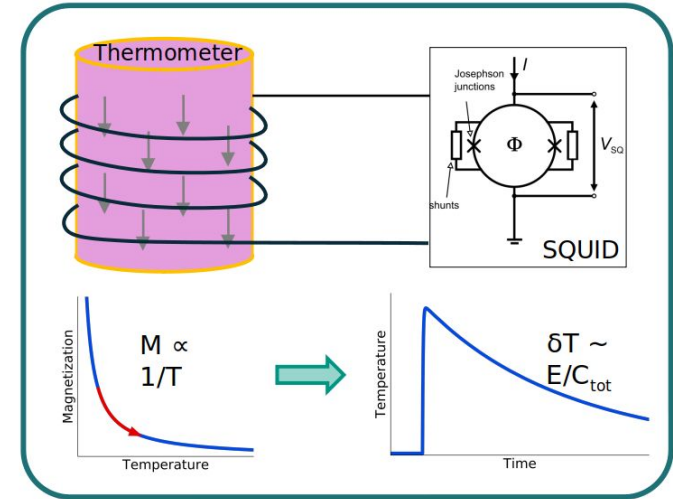
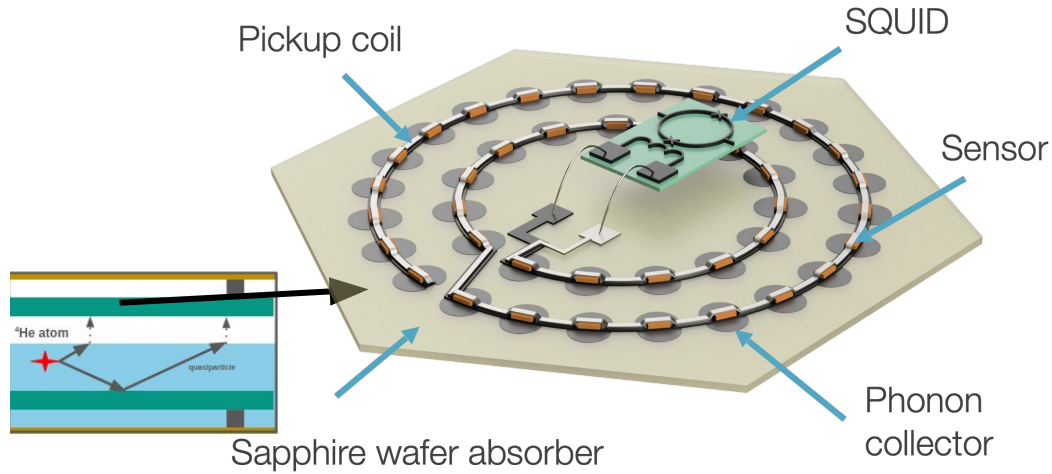

Ongoing R&D

- R&D cell operating in Heidelberg
- Filled with helium → cell superfluid leak tight
- Operated submerged MMC-based calorimeter

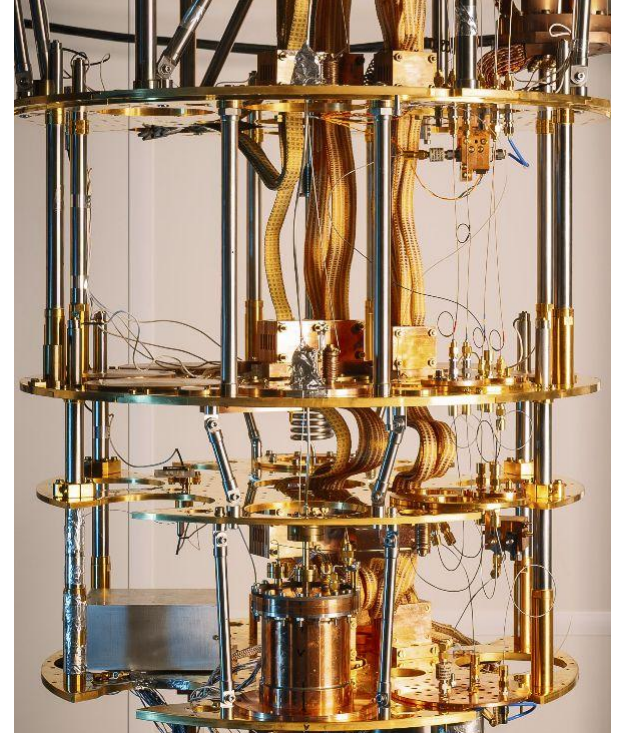
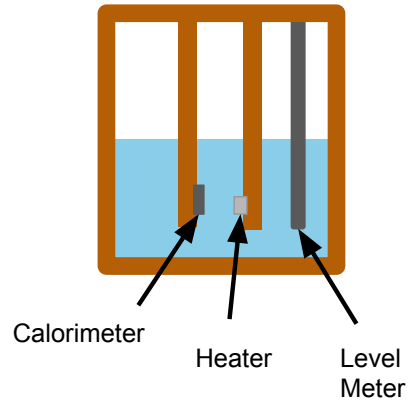
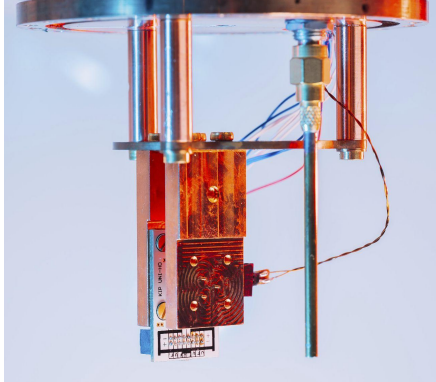

- Measurement @15 mK for ~40 hours
- No calibration source present
- **Muons** deposit energy $\mathcal{O}(100\text{keV})$
- Detection of energy fraction deposited as **UV photons**
→ Collection efficiency reduced by copper boards

Reconstruction of background particle spectrum

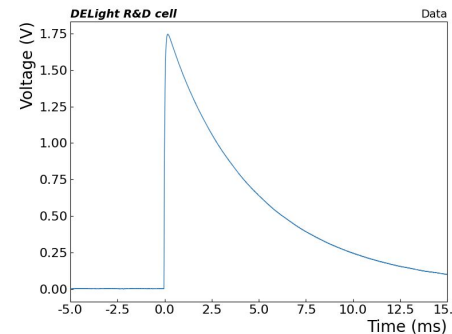
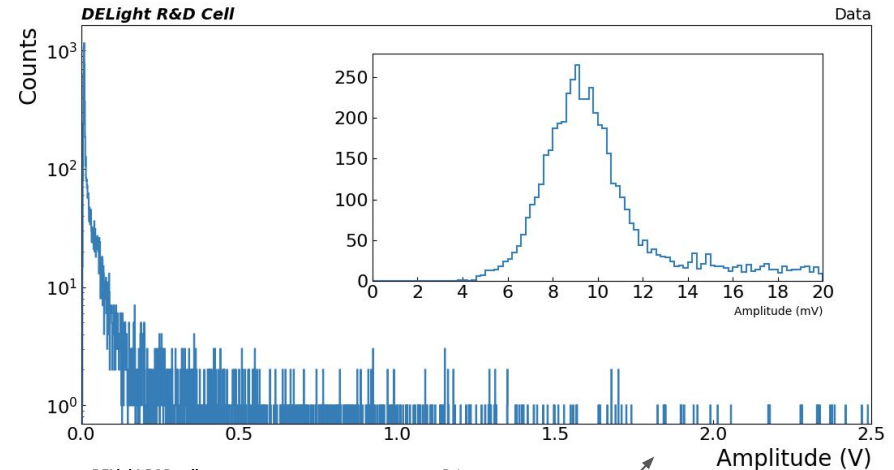

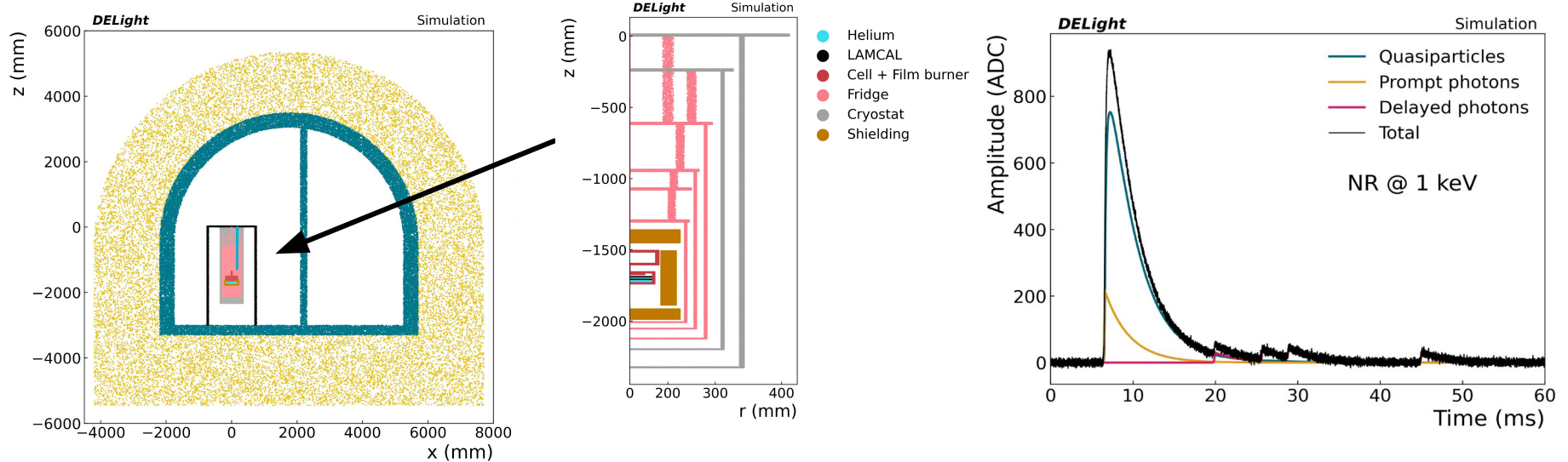

- Preliminary geometry implemented in Geant4
- Signal simulation (including quasiparticles) + waveform simulation
- Background model (underground lab)

Background model used for sensitivity projections

- Radiogenic ER
- VdA Muon ER
- Solar Neutrino-Electron Scattering
- Radiogenic NR
- VdA Muon NR
- Solar CEvNS
- Photonuclear NR
- Total
- Total, No Shielding

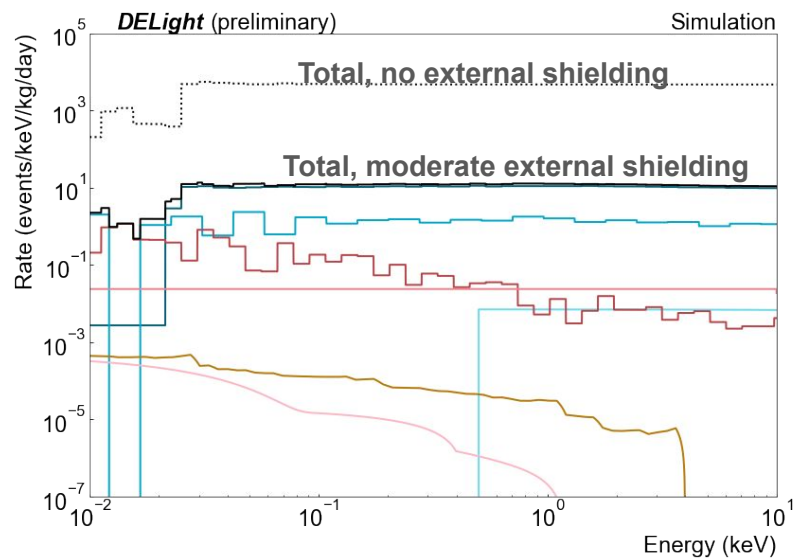

Phase-I 1 kg·d exposure

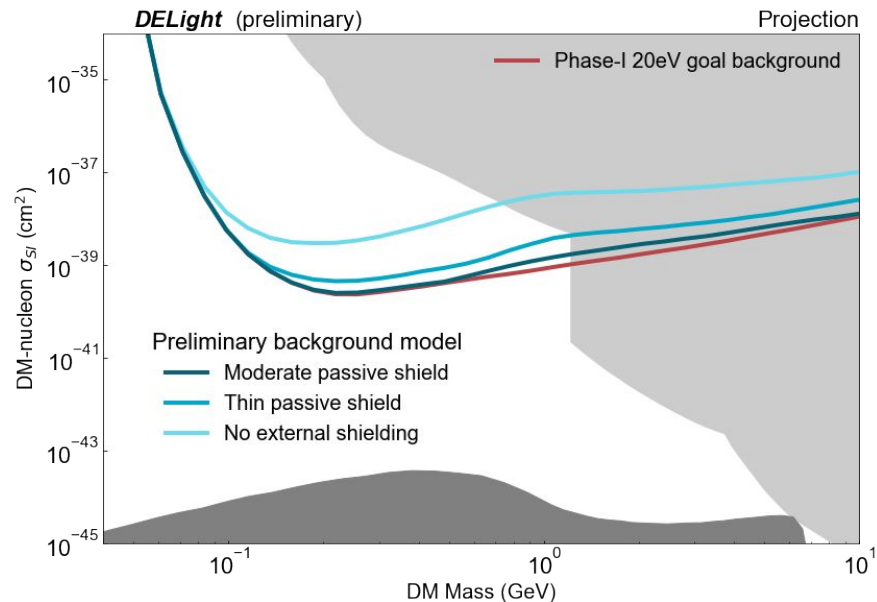

- DELIGHT is funded and in design phase
 - operating R&D cell above ground
- Will go underground
- Phase-I
 - 20 eV threshold
 - 1 kg·d exposure (1 week)
 - New parameter space
- Phase-II
 - 10 eV threshold
 - 100 kg·d exposure

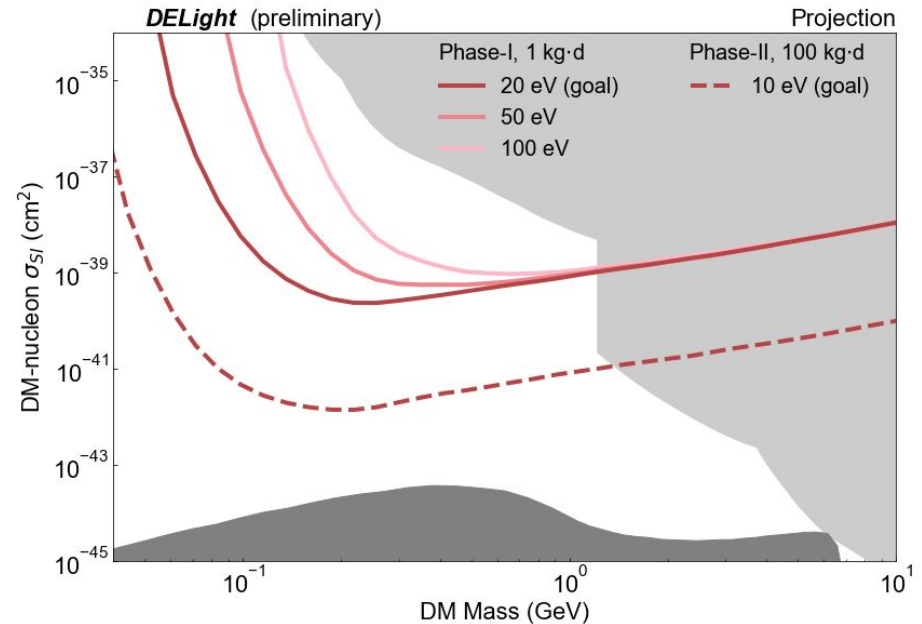

Backup

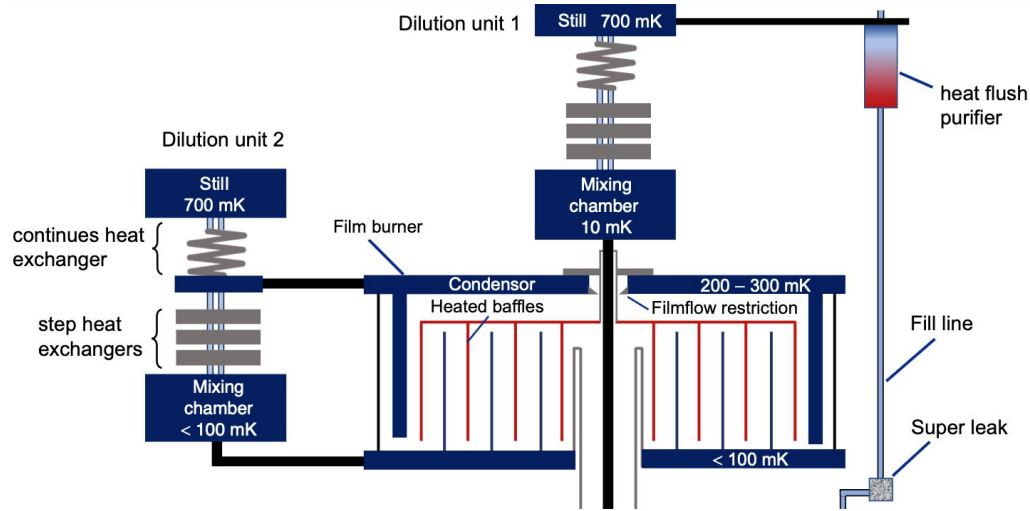

- Additional structure close to the helium cell
- Needed against superfluid helium moving up to upper calorimeters
- Already tested by HERON collaboration



- $^3\text{He}/^4\text{He}$ dry dilution refrigerator
- Small capillary line for ^4He filling
→ thermally coupled at every stage
- Indium sealings
- Burst disk and an exhaust line
→ for the case of overpressure



The Level Meter

