

PandaX Neutrino Program

Ke HAN 韩柯 (SJTU)

For the PandaX Collaboration

2026/6/24



Outline

1. Introduction to PandaX and liquid xenon TPC
2. PandaX-4T
 1. Double beta decay results
 2. Solar neutrino results
3. Future: PandaX-xT

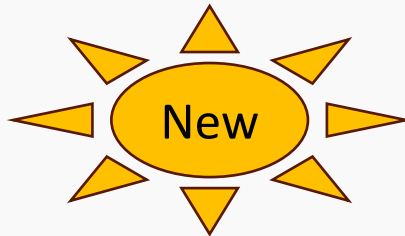



PandaX: Particle and astrophysical Xenon Experiment



PandaX-I: 120kg
LXe (2009 – 2014)



PandaX-II: 500kg
LXe (2014 – 2018)

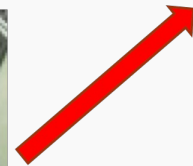

PandaX-4T LXe
(2020-)

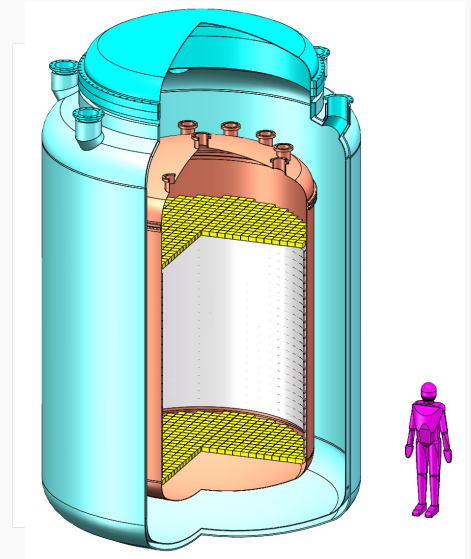

PandaX-xT LXe
(future)

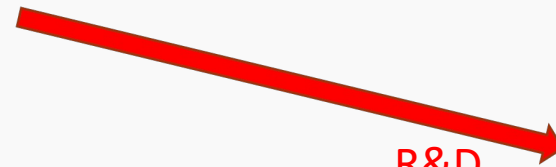

PandaX-III: 100kg - 1 ton
HPXe for $0\nu\beta\beta$ (future)

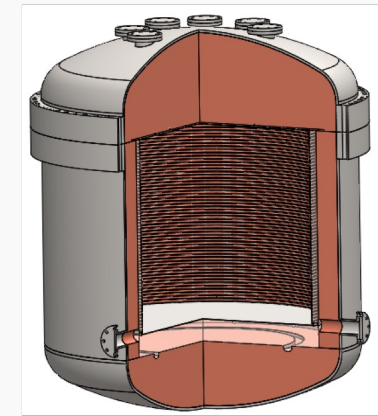



CJPL-II

- 2400 m rock overburden
- UG volume: 330,000 m³
- μ -flux: $\sim 96 \text{ m}^{-2}\text{yr}^{-1}$

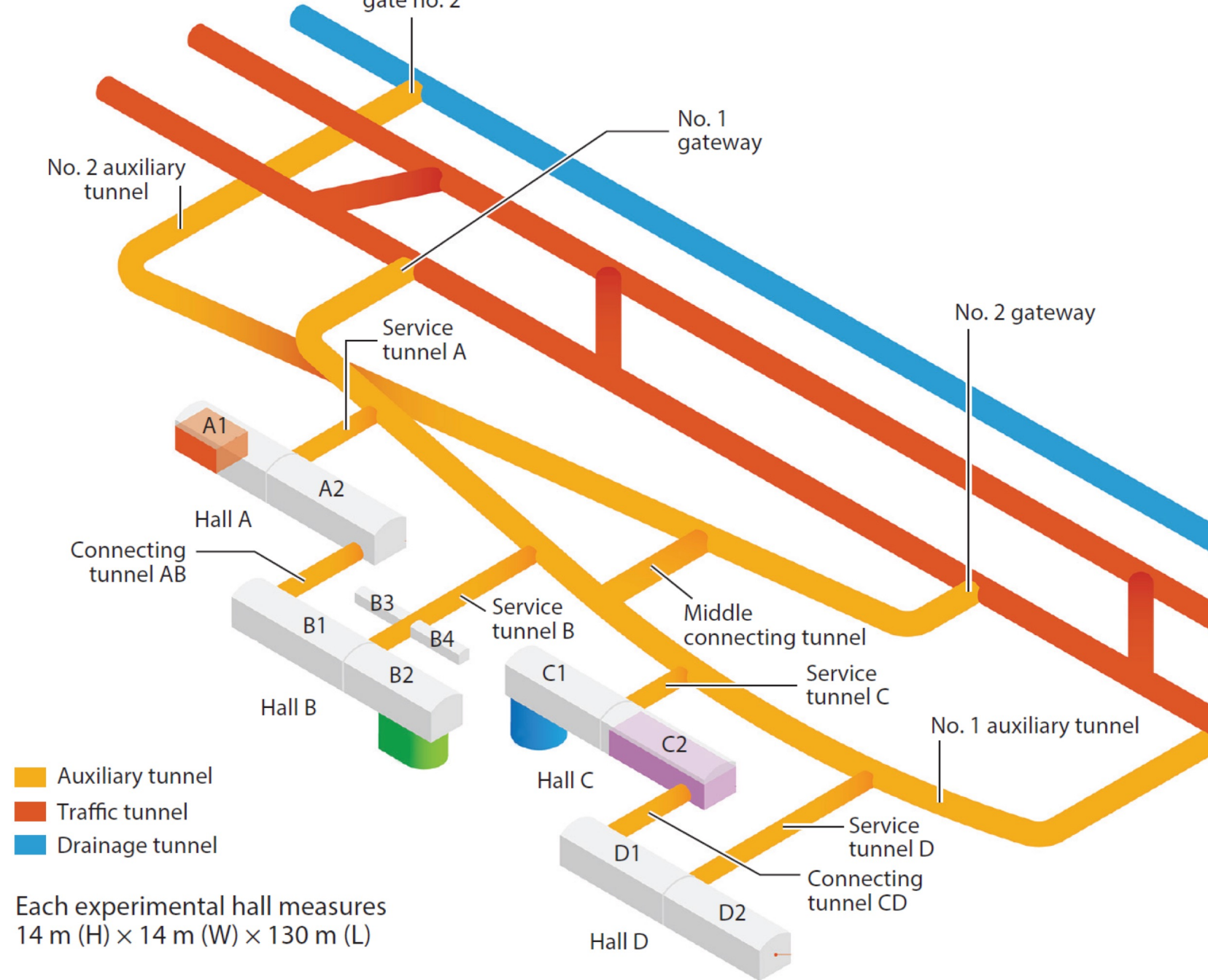
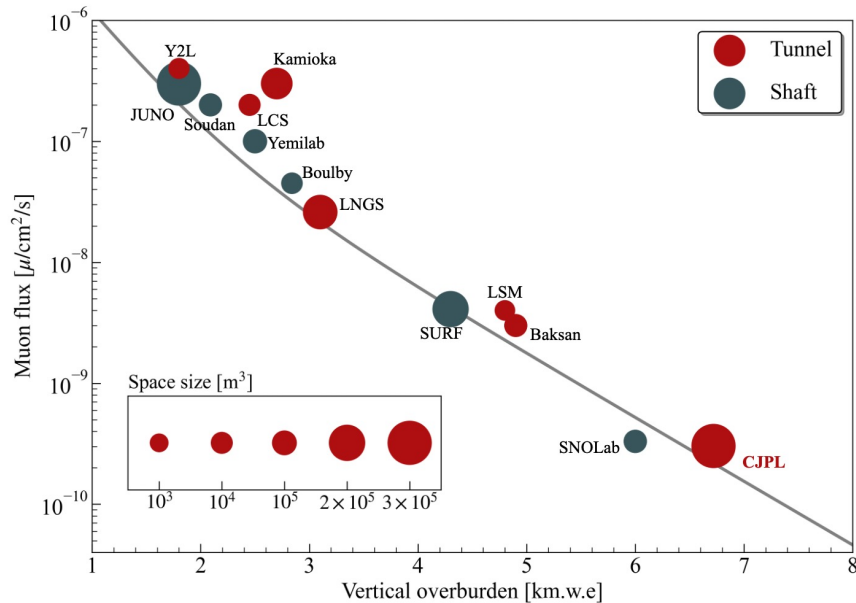

PandaX-4T @ Hall B2 of CJPL-II

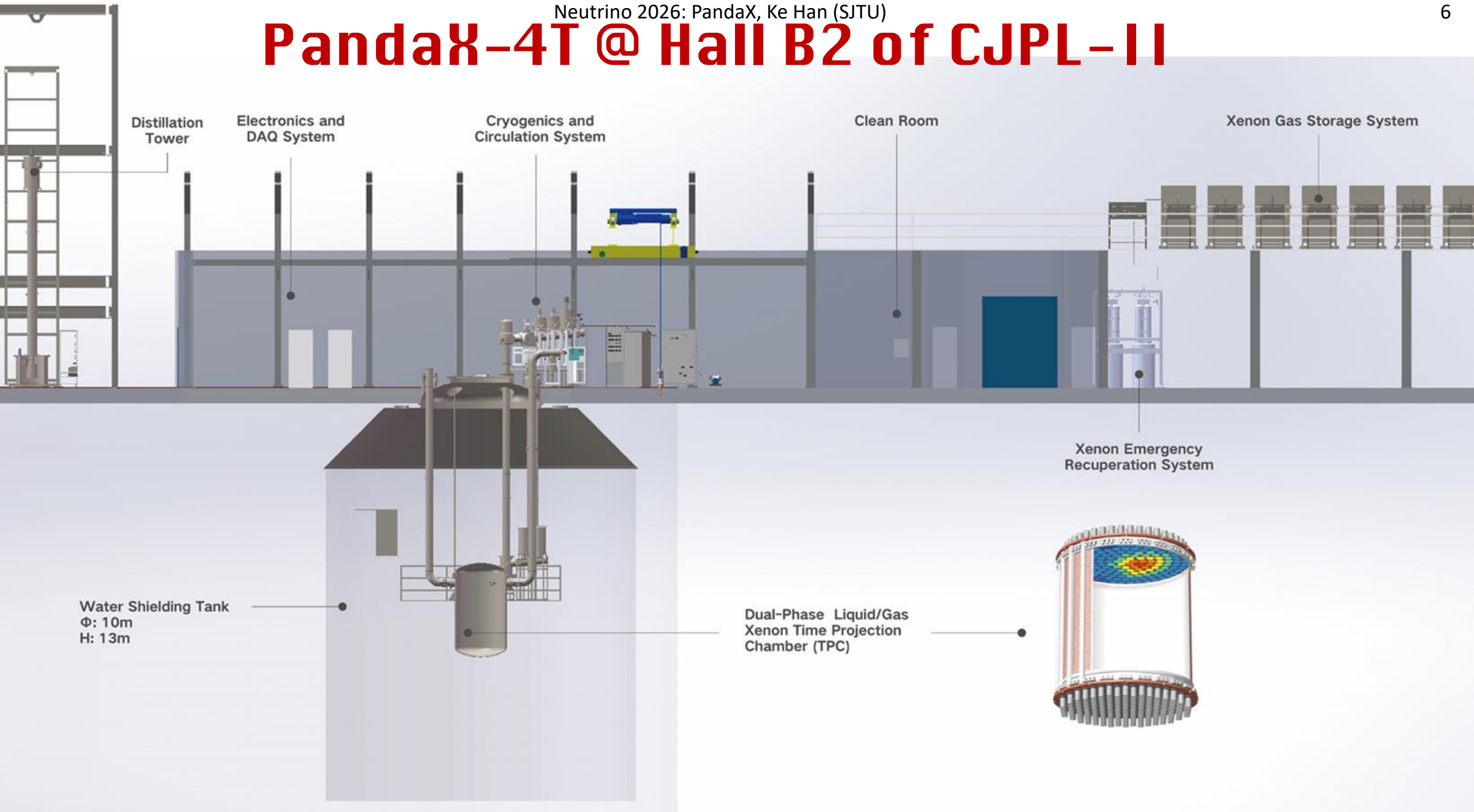



PandaX-4T

- A multi-ton dual-phase xenon TPC at B2 hall of China Jinping Underground Laboratory
- 1.2 m (D) \times 1.2 m (H); Sensitive volume: 3.7-ton LXe; 3-inch PMTs: 169 top / 199 bottom
- Ultrapure water shielding: 4 m in all directions

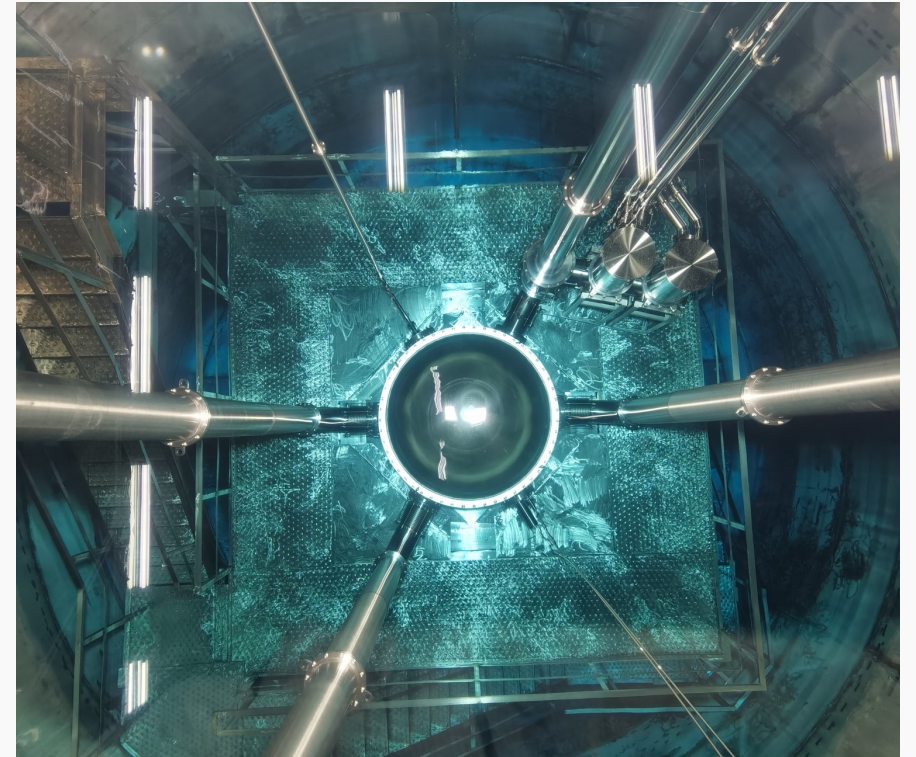
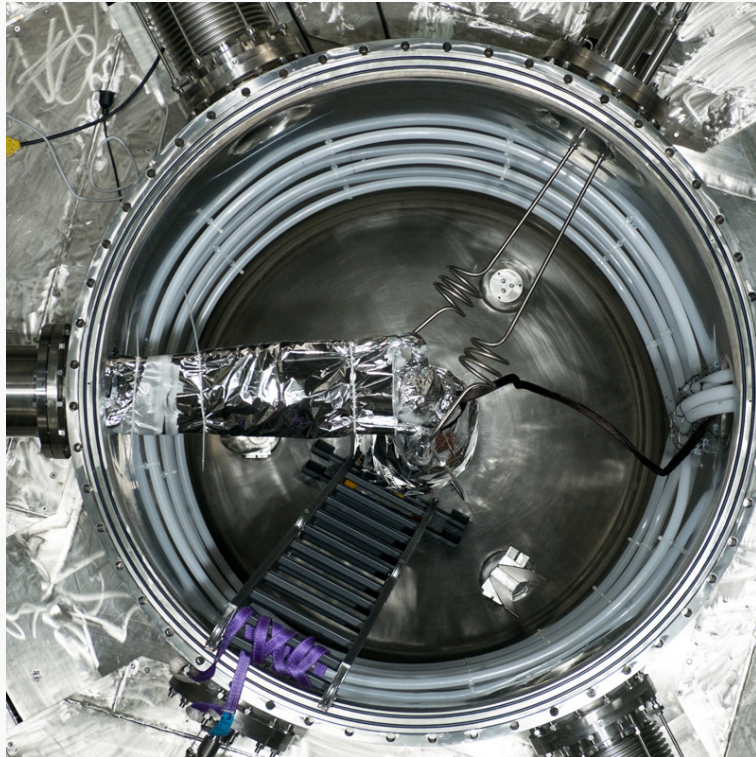



PandaX-4T timeline

2020/11 – 2021/04	Commissioning (Run0) 95 days
2021/07 – 2021/10	Tritium removal
2021/11 – 2022/05	Physics run (Run1) 164 days
2022/09 – 2023/12	CJPL B2 hall construction xenon recuperation, detector upgrade
2024/01 – 2026/04	Physics run (Run2)
Current Status	Shut down on Apr. 15th, 2026

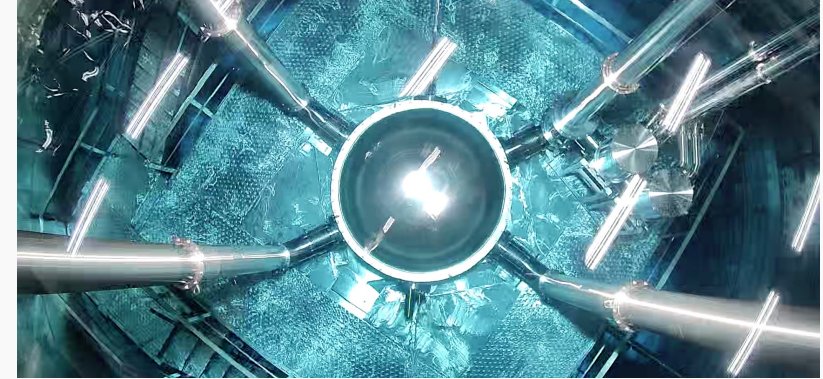



Liquid Xenon Time Projection Chamber (LXe TPC)

- Prompt scintillation signal (**S1**) followed by drift electron signal (**S2**)
- Measures the **3D position, energy, and time**
- Large monolithic target: high signal efficiency and effective self-shielding
- LXe TPC as a **Total-Absorption 5D Calorimeter**

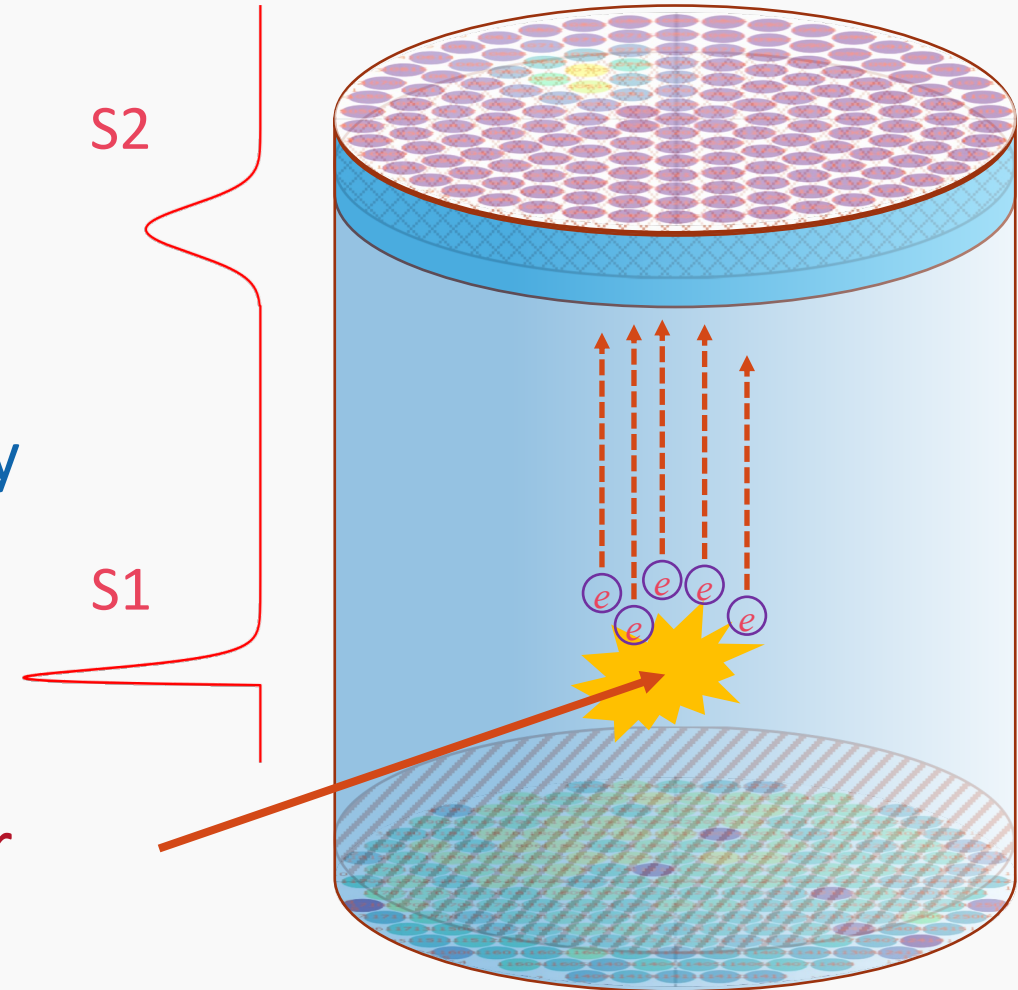



ER (electron recoil) and NR (nuclear recoil)

ER

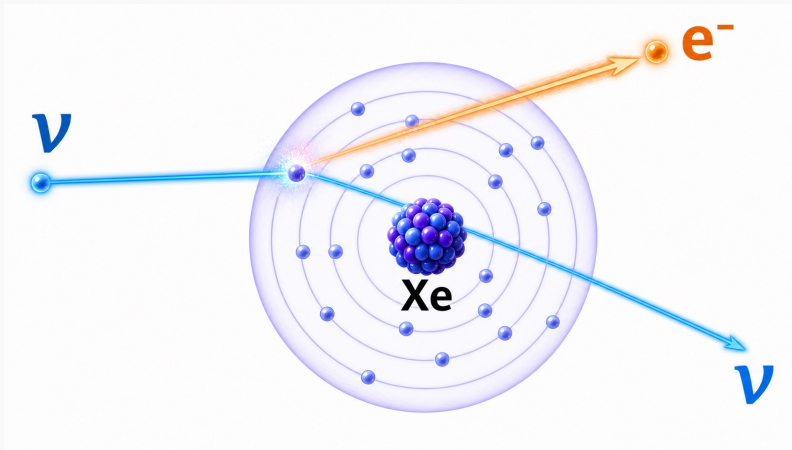

NR

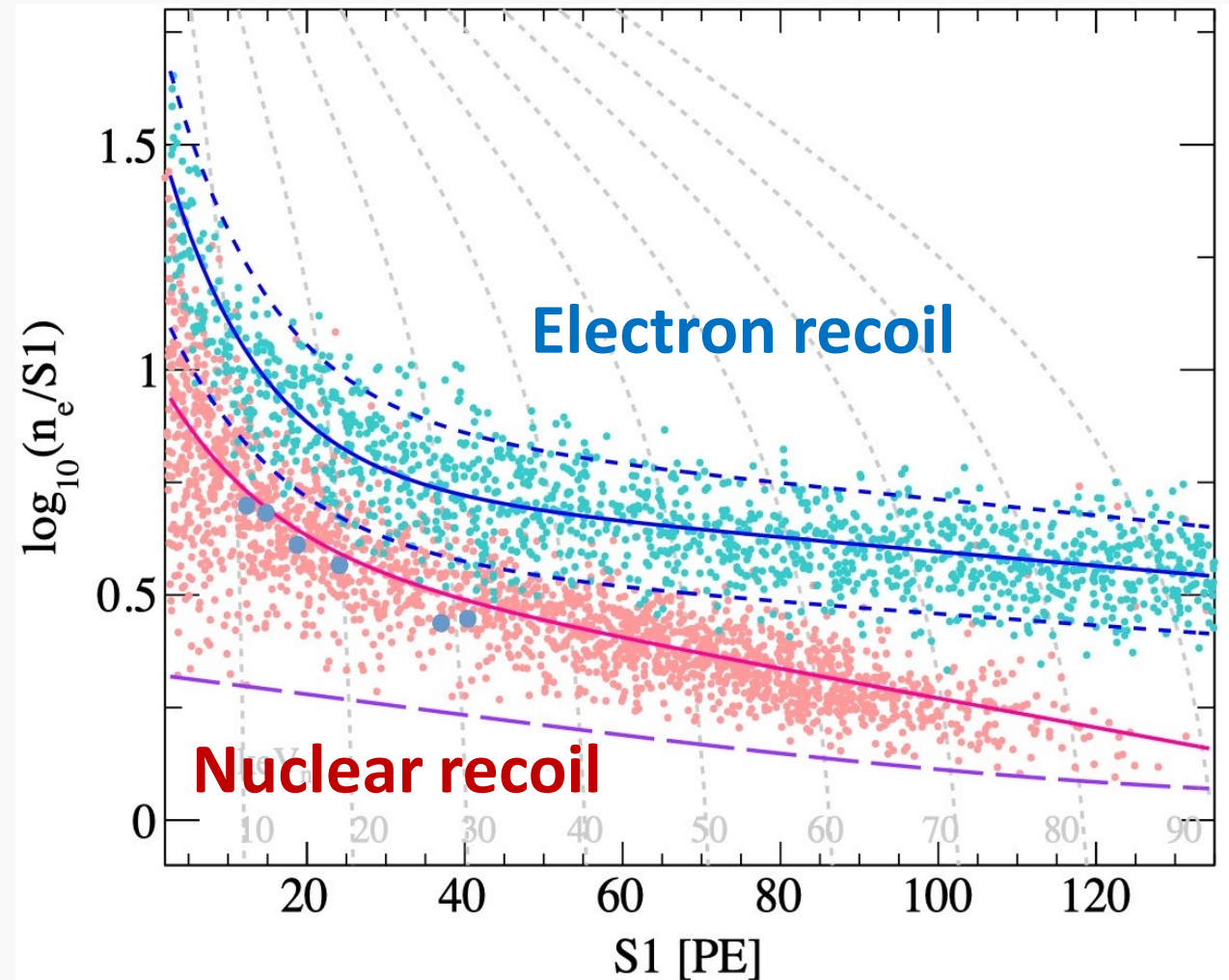
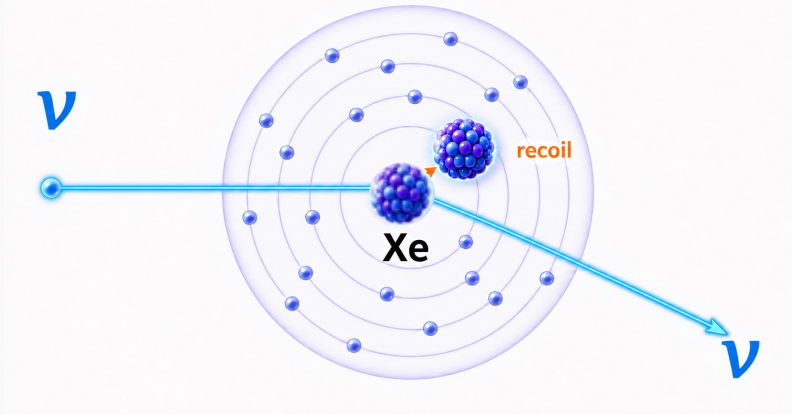



SS (Single Site) and MS (Multi Site) event

SS event

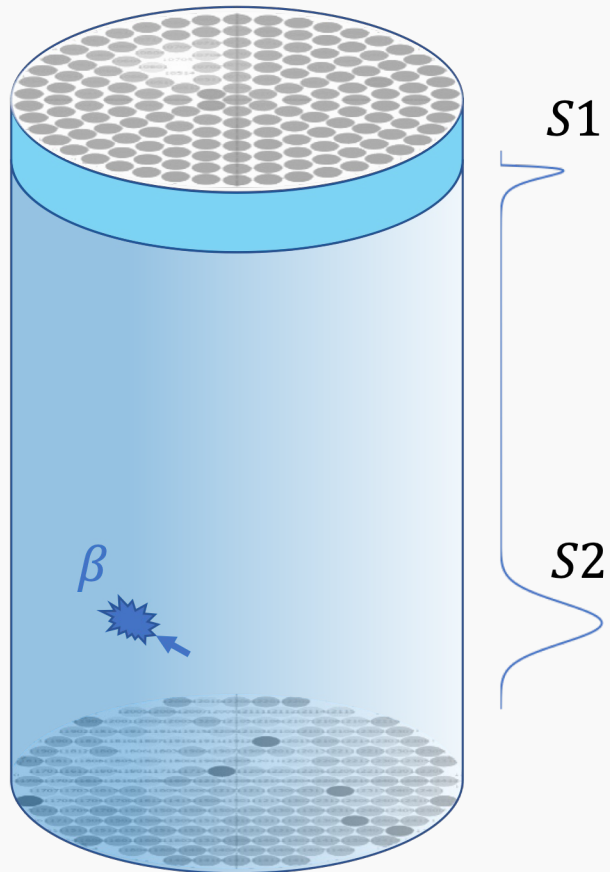

MS event with $\beta + \gamma$

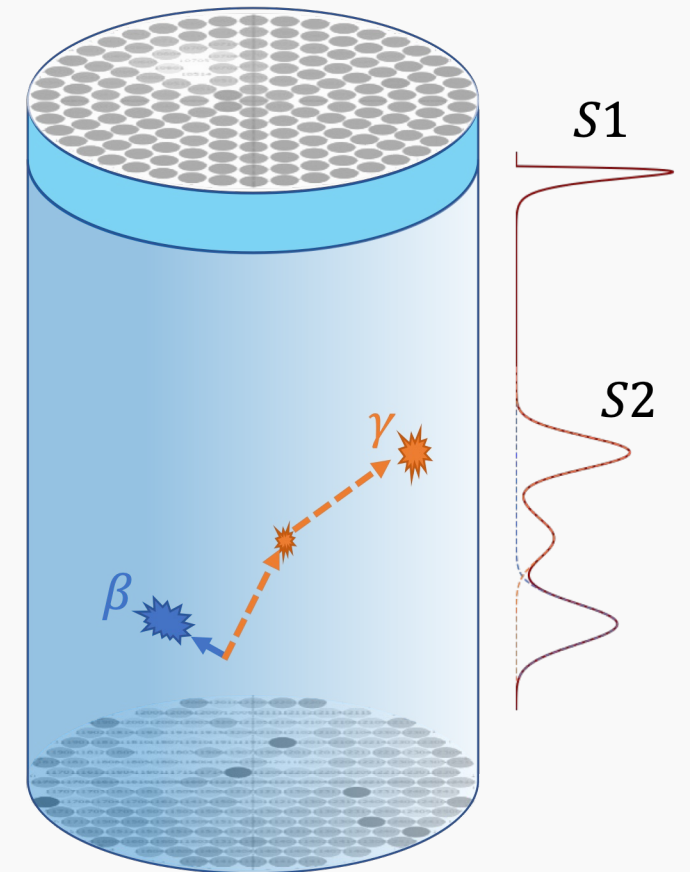
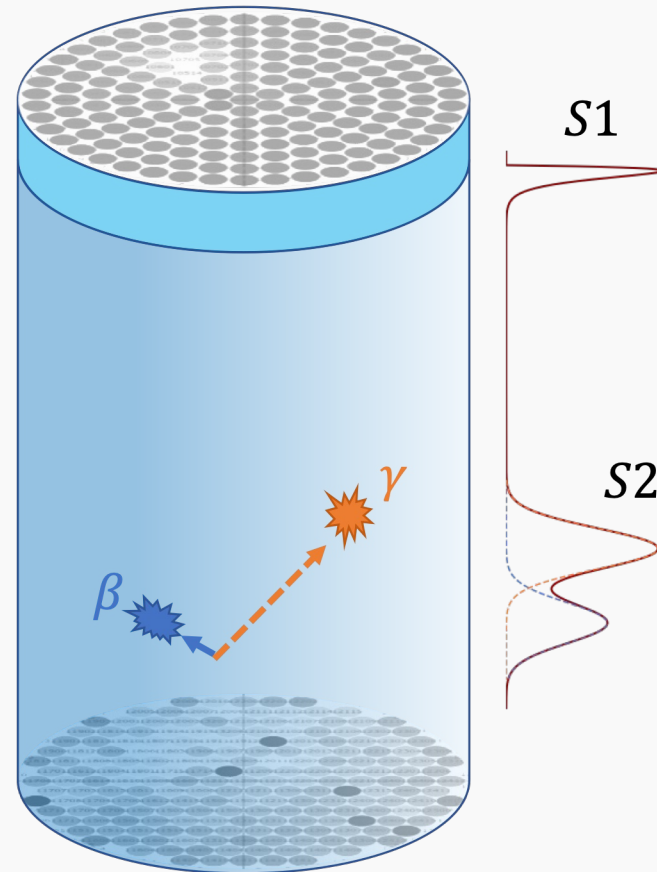

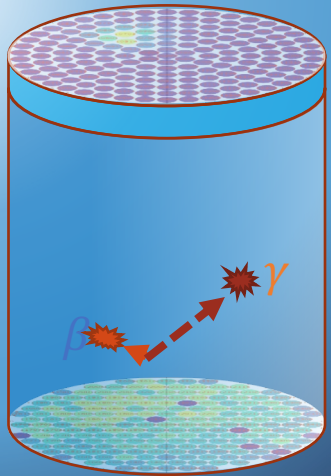

5D calorimeter

3D position

Time

Energy

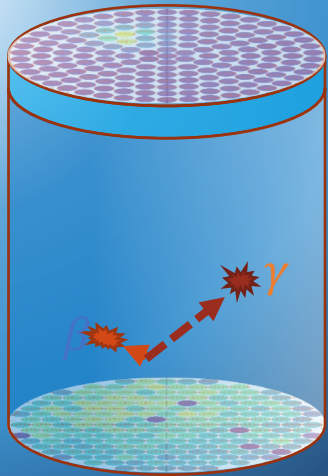

5D calorimeter

Event info

3D position

ER/NR

Time

SS/MS

Energy

Evolution

Fidiculation



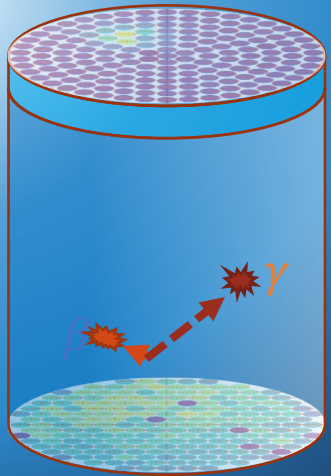

5D calorimeter

Event info

Physics

3D position

ER/NR

WIMP DM

Time

SS/MS

$0\nu\beta\beta$

Energy

Evolution

Solar ν

Fiducialization

Nuclear

Exotics

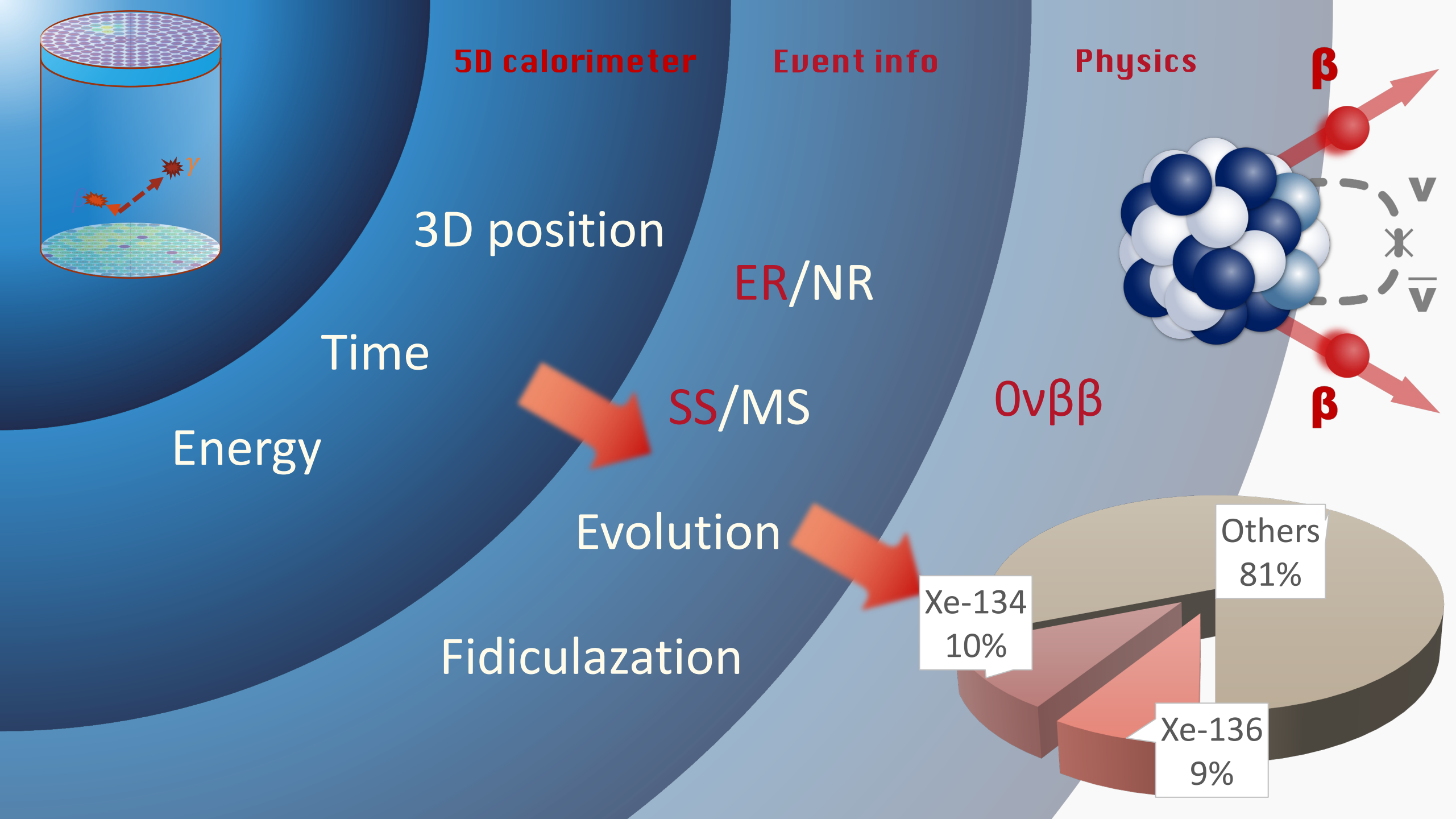



Neutrinoless double beta decay ($0\nu\beta\beta$)

- Neutrinoless double beta decay ($0\nu\beta\beta$): Majorana fermions and lepton number violation
- SM-allowed: 2-neutrino double beta decay ($2\nu\beta\beta$)

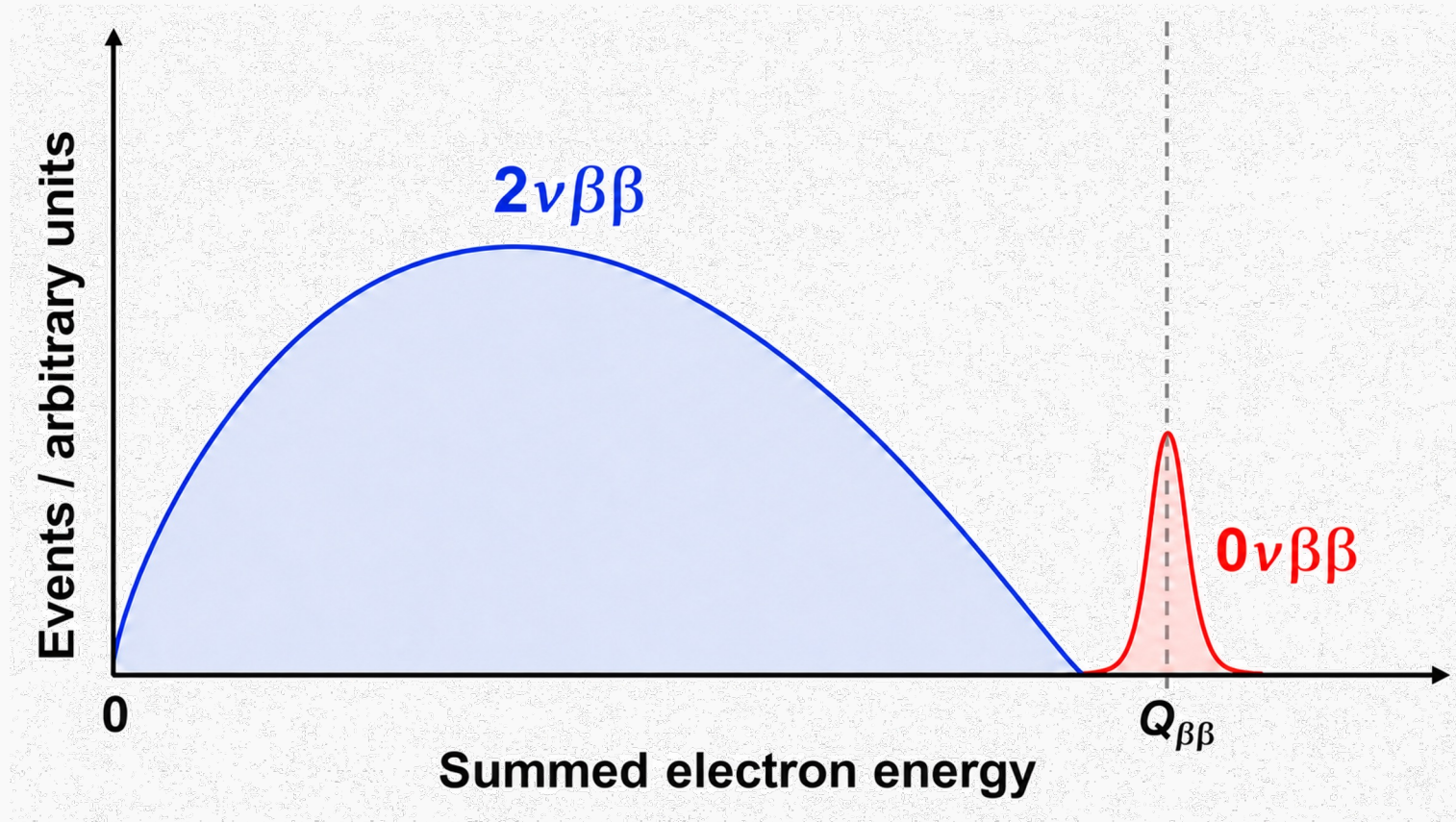



^{136}Xe $2\nu\beta\beta$ half-life measurement

- A **near-complete** ^{136}Xe $2\nu\beta\beta$ spectrum from 20 keV to endpoint
- The **most precise** half-life measurement: $(2.14 \pm 0.05) \times 10^{21}$ yr
- Constrains higher-order matrix elements contribution $\xi_{31}^{2\nu}$ and Majoron emissions

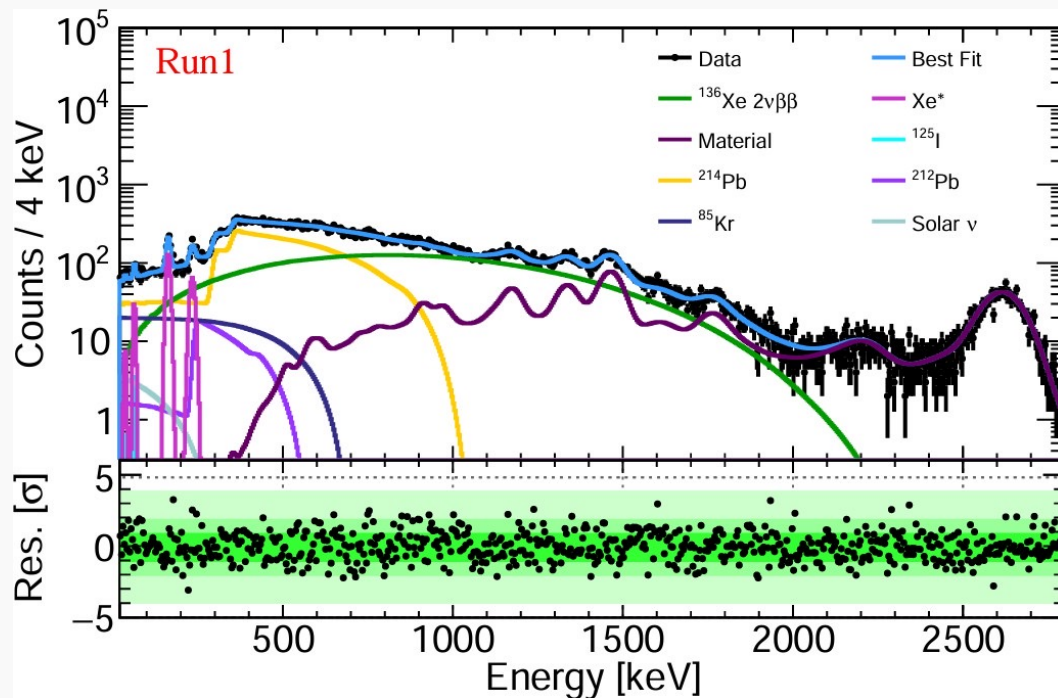

PRL 136, 162501 (2026)

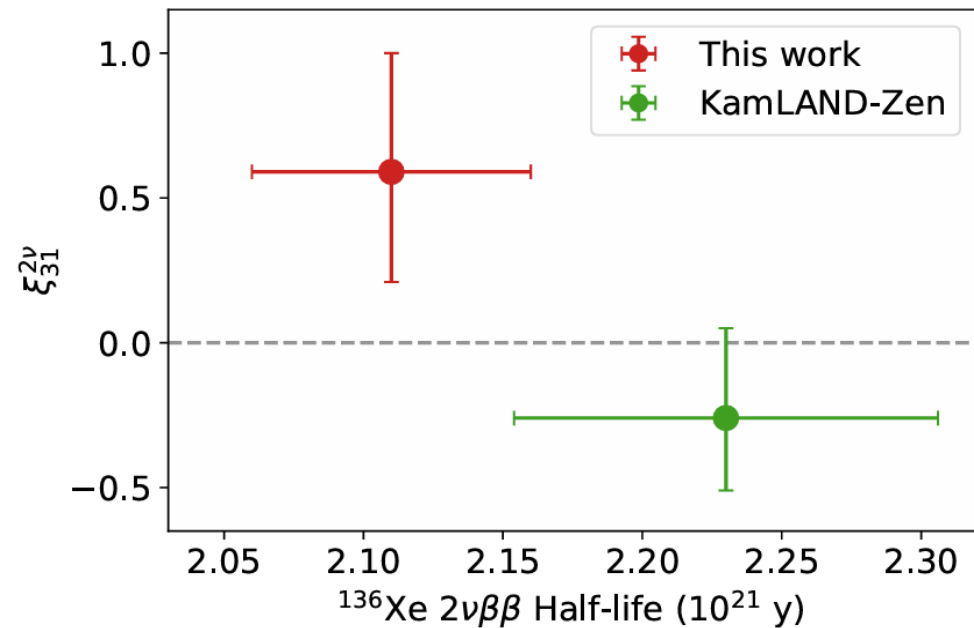

$$(T_{1/2}^{2\nu})^{-1} = (g_A^{\text{eff}})^4 |M_{\text{GT}}^{2\nu}|^2 (G_0^{2\nu} + \xi_{31}^{2\nu} G_2^{2\nu})$$



^{136}Xe $0\nu\beta\beta$ limit

- 44.6 kg · yr isotope exposure
- Stringent half-life limit from a natural xenon detector: 2.1×10^{24} yr (90% C.L.)
- The effective Majorana mass constraint: $< (0.4-1.6)$ eV

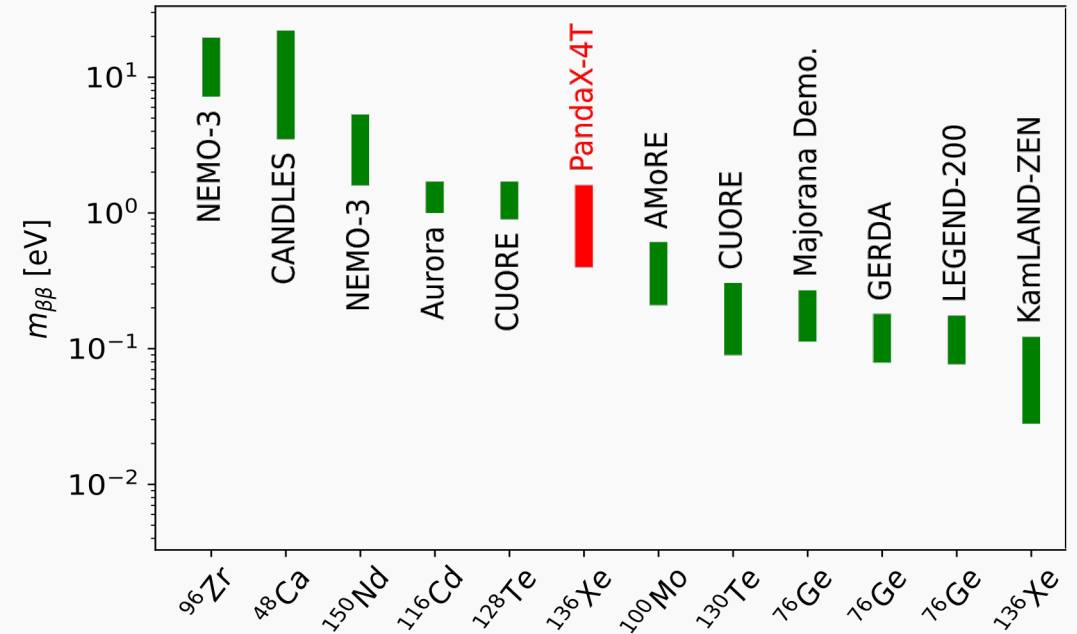
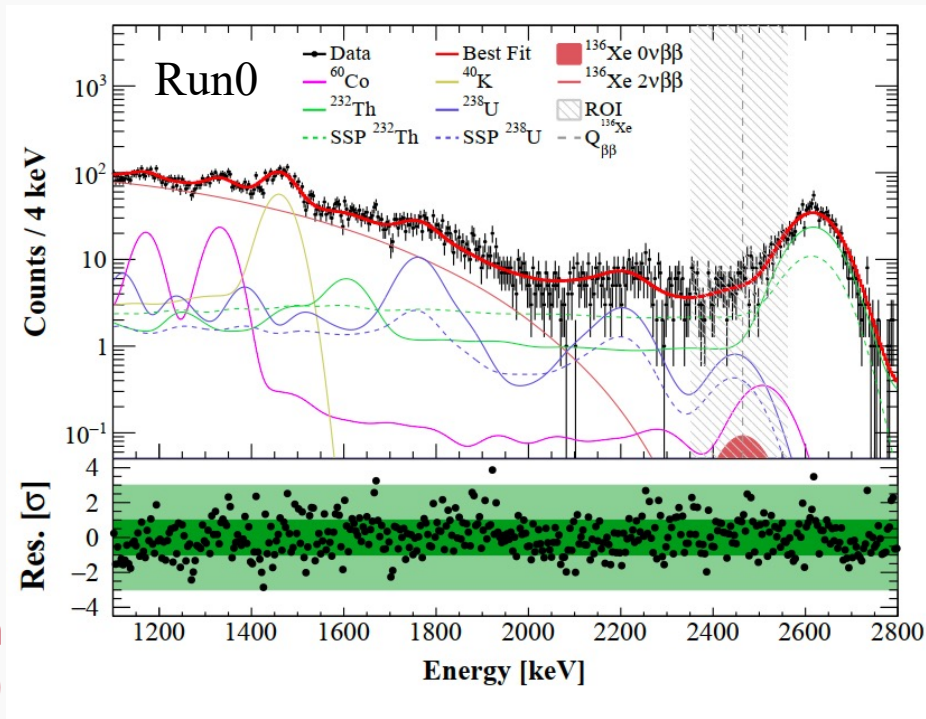



$^{134}\text{Xe} (0)2\nu\beta\beta$ searches

- $Q=826$ keV; Half-life from theoretical predictions: $10^{24} - 10^{25}$ yr; Never been observed
- PandaX-4T: more ^{134}Xe ; much less ^{136}Xe ; wider energy range
- 90% CL lower limits on the half-life: $T_{1/2}^{2\nu\beta\beta} > 2.8 \cdot 10^{22}$ yr and $T_{1/2}^{0\nu\beta\beta} > 3.0 \cdot 10^{23}$ yr

	PandaX-4T	EXO-200 (2017)
^{134}Xe mass	68.7 kg	18.1 kg
^{136}Xe abundance	8.90%	81%
Analysis threshold	200 keV	460 keV
Live Time	94.9 days	600 days

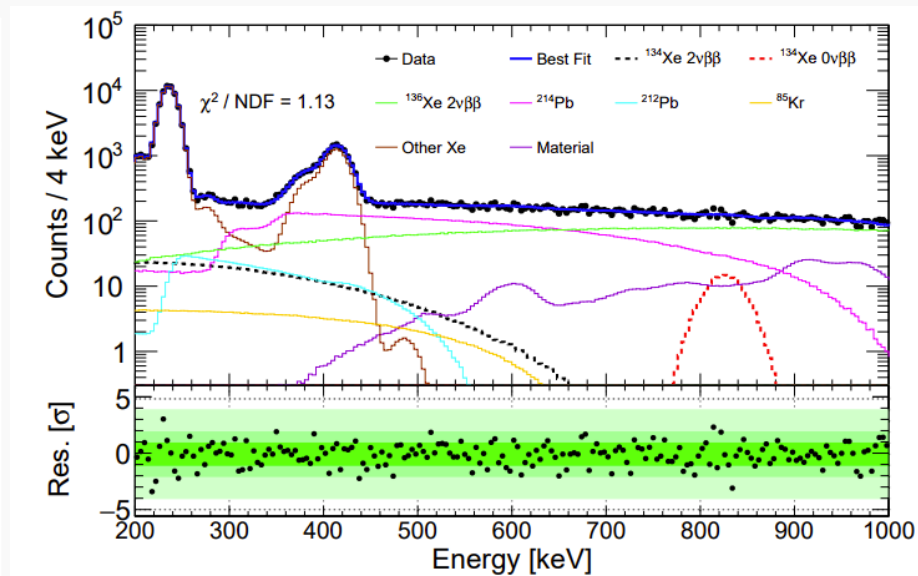

PRL 132, 152502 (2024)

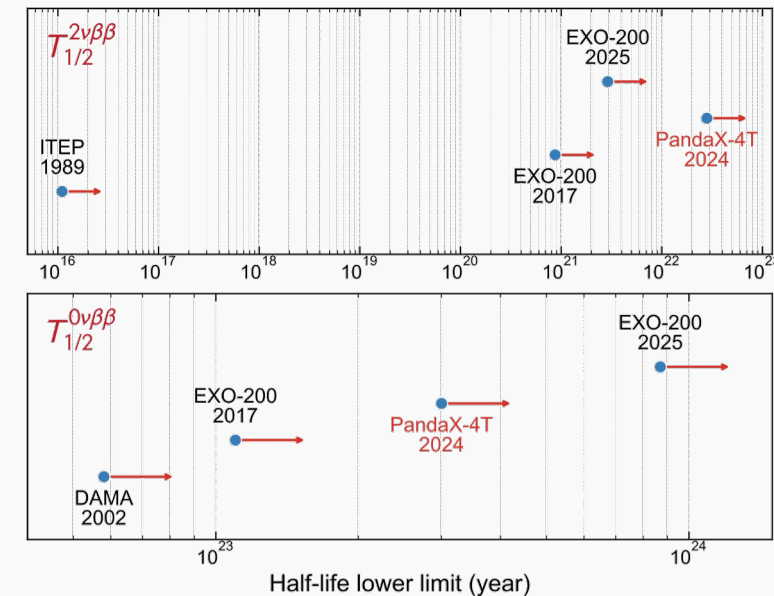

EXO-200: 2511.13990, PRD 96, 092001 (2017)
 ITEP: PLB 223, 273 (1989); DAMA: PLB 527, 182 (2002)

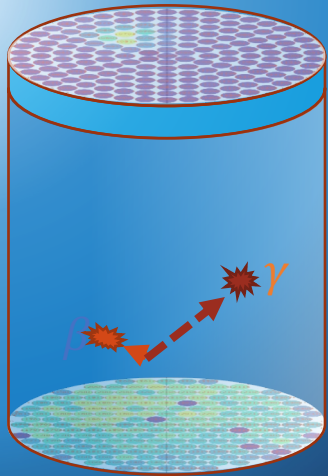

5D calorimeter

Event info

Physics

3D position

ER/NR

WIMP DM

Time

SS/MS

$0\nu\beta\beta$

Energy

Evolution

Solar ν

Fiducialization

Nuclear ν

Exotics

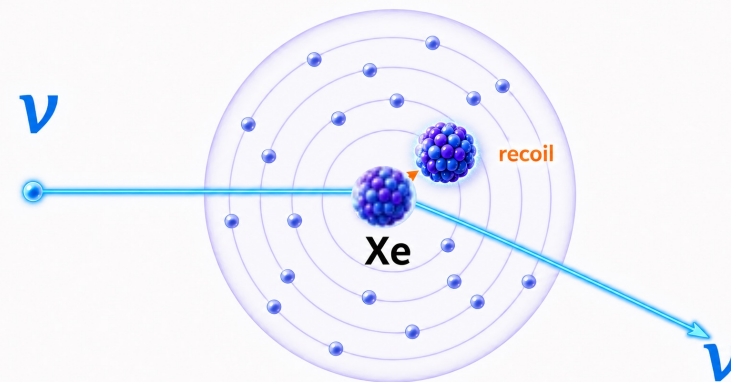



Solar neutrino as intrinsic background for DM direct detection

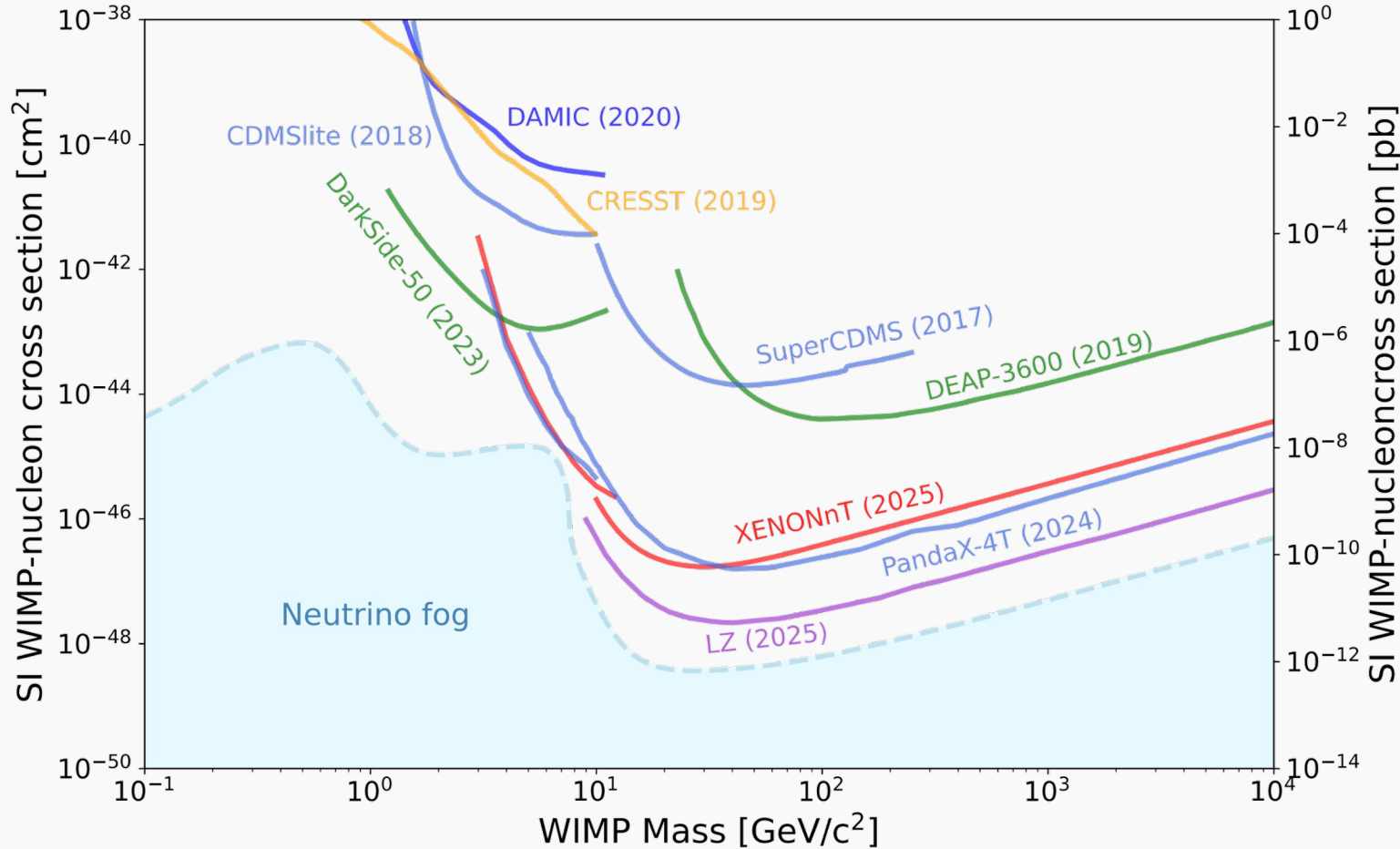

PDG2025

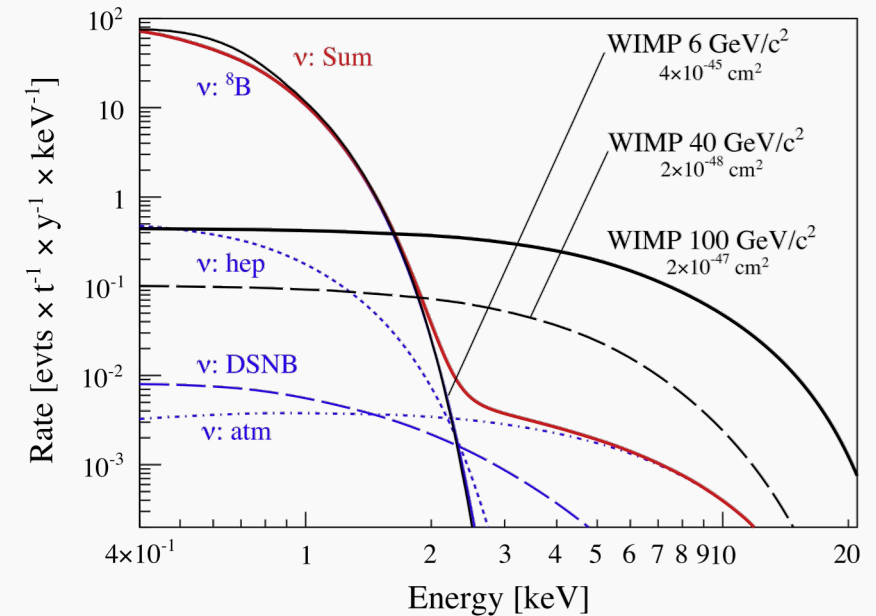
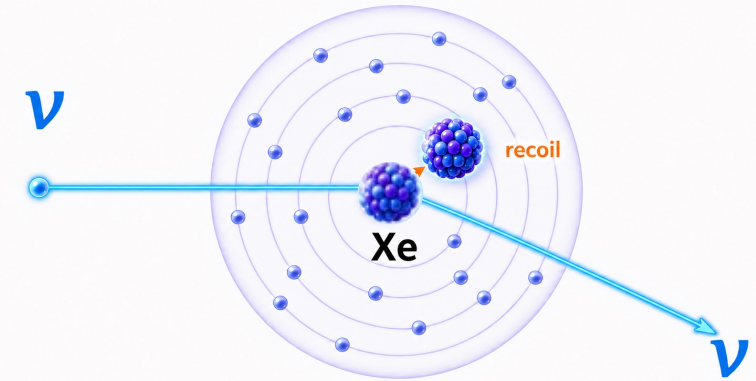

JCAP01(2014)044



Solar ^8B neutrinos

- First indication of solar ^8B CEvNS signal
 - Significance: 2.64σ
 - Fitted flux $(8.4 \pm 3.1) \times 10^6 \text{ cm}^{-2} \text{ s}^{-1}$

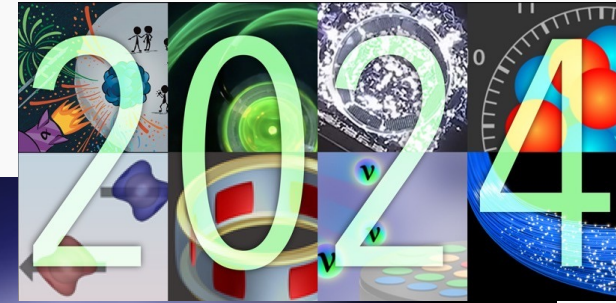

XENONnT + PandaX

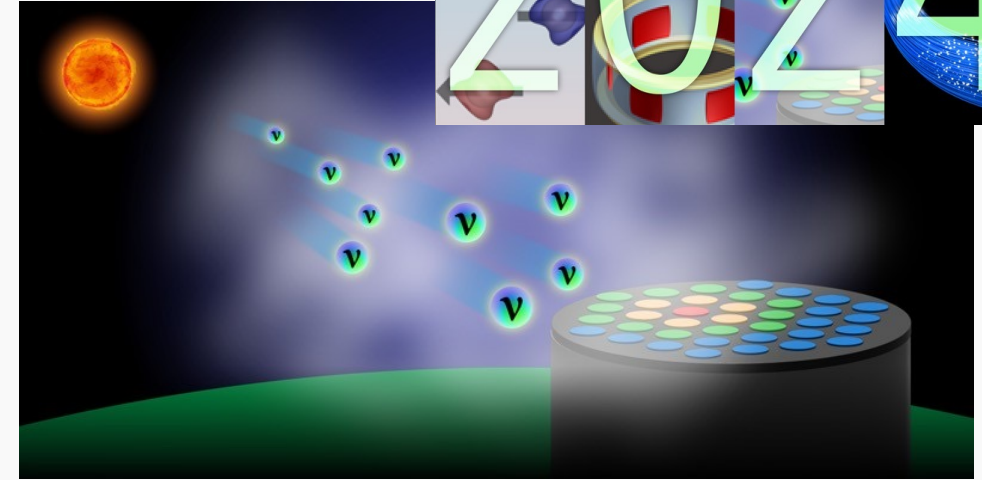

Best-fit ^8B yield

Paired: 3.5 ± 1.3 events

S2only: 75 ± 28 events

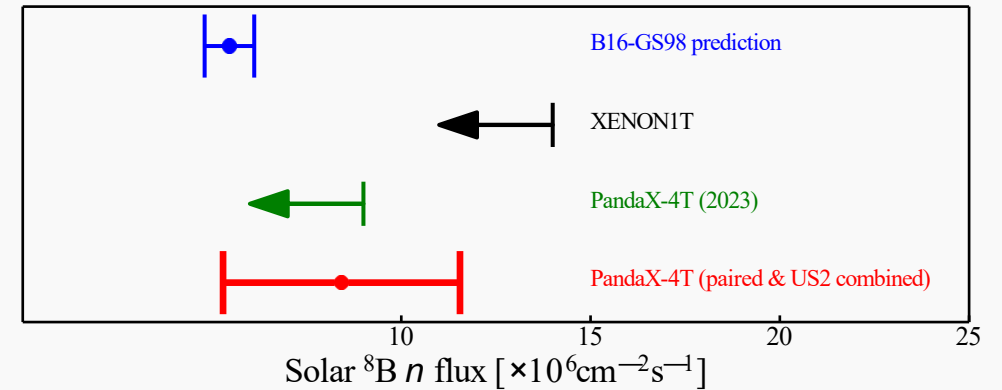
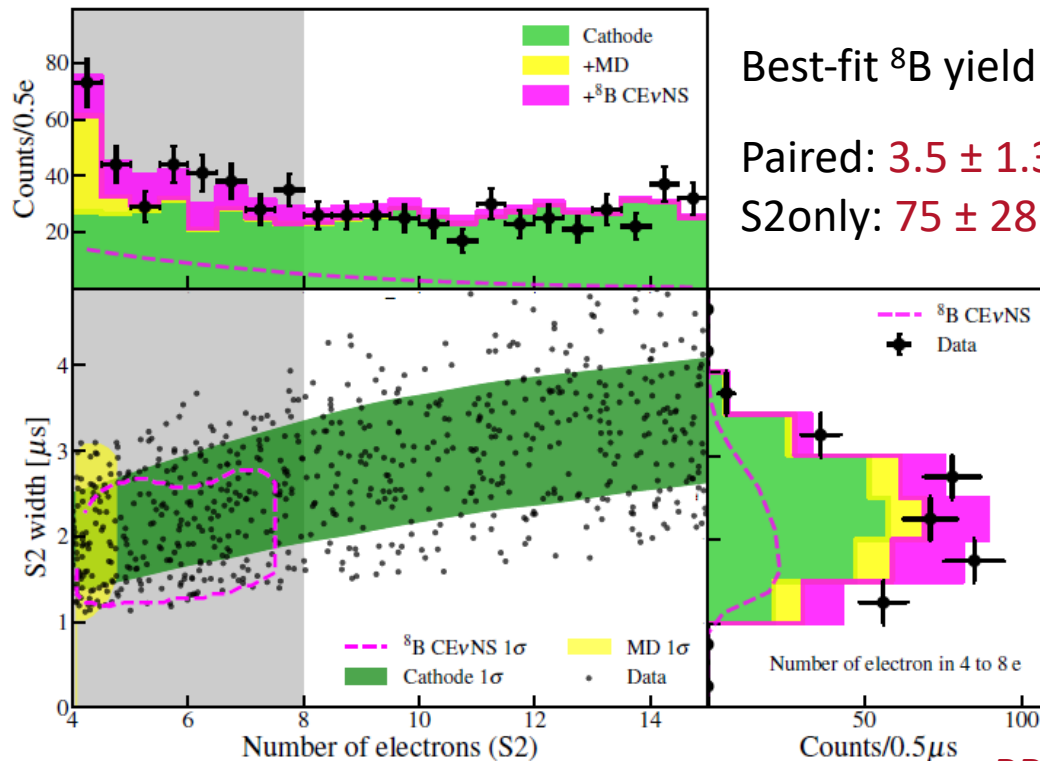

Latest: 4.5σ from LZ (2512.08065)
 3.3σ from XENONnT (2604.06002)

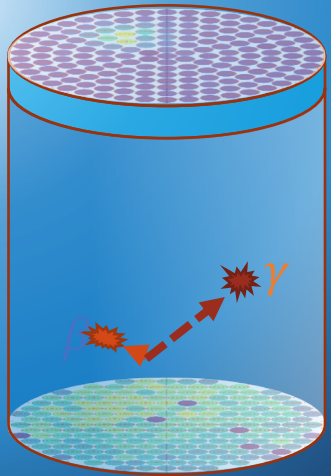

5D calorimeter

Event info

Physics

3D position

ER/NR

WIMP DM

Time

SS/MS

$0\nu\beta\beta$

Energy

Evolution

Solar ν

Fiducialization

Nuclear ν

Exotics

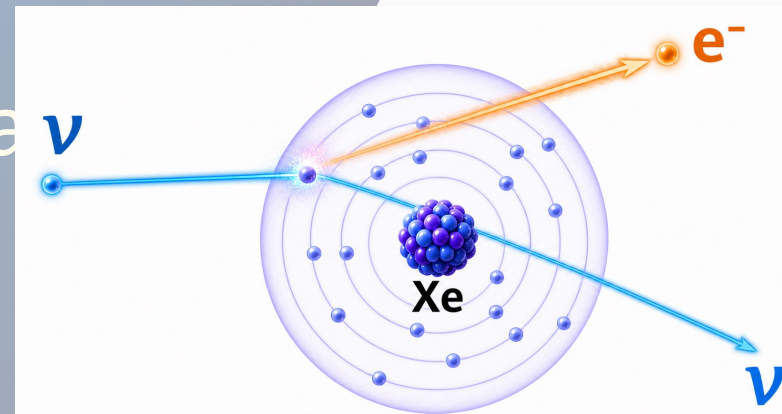



Solar pp neutrino scattering on electrons

- Leading result from Borexino with a recoil energy of >165 keV
- PandaX-4T: traditionally a DM detector, i.e. **low energy threshold**

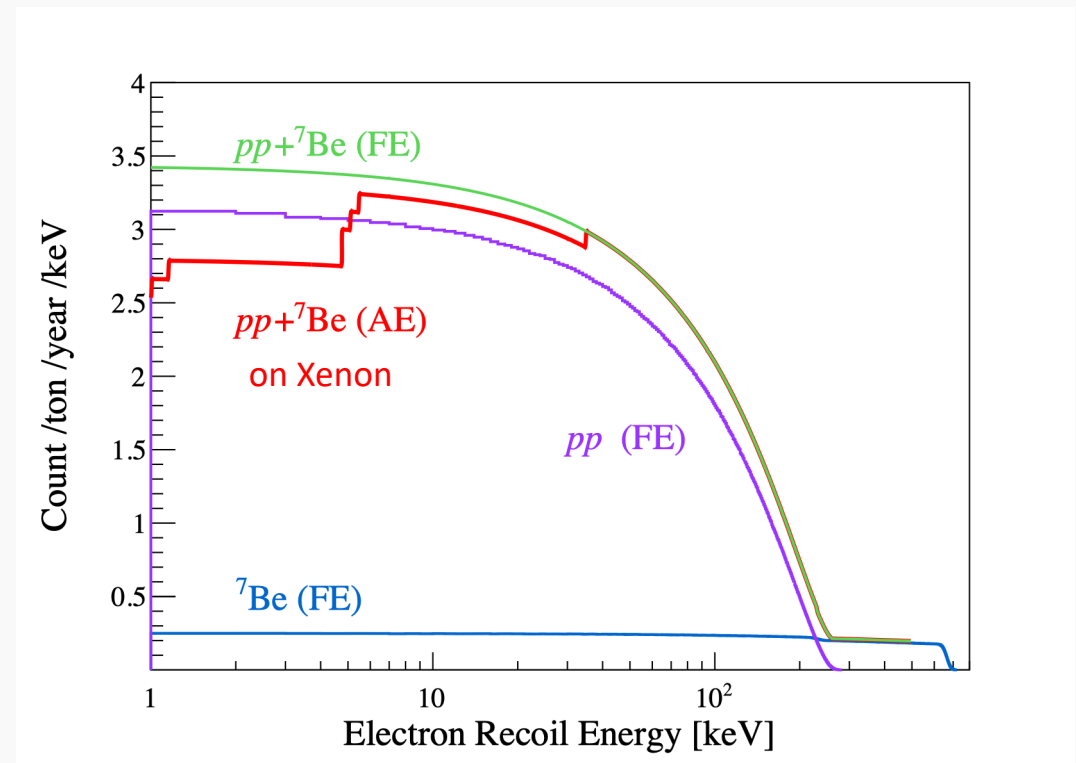
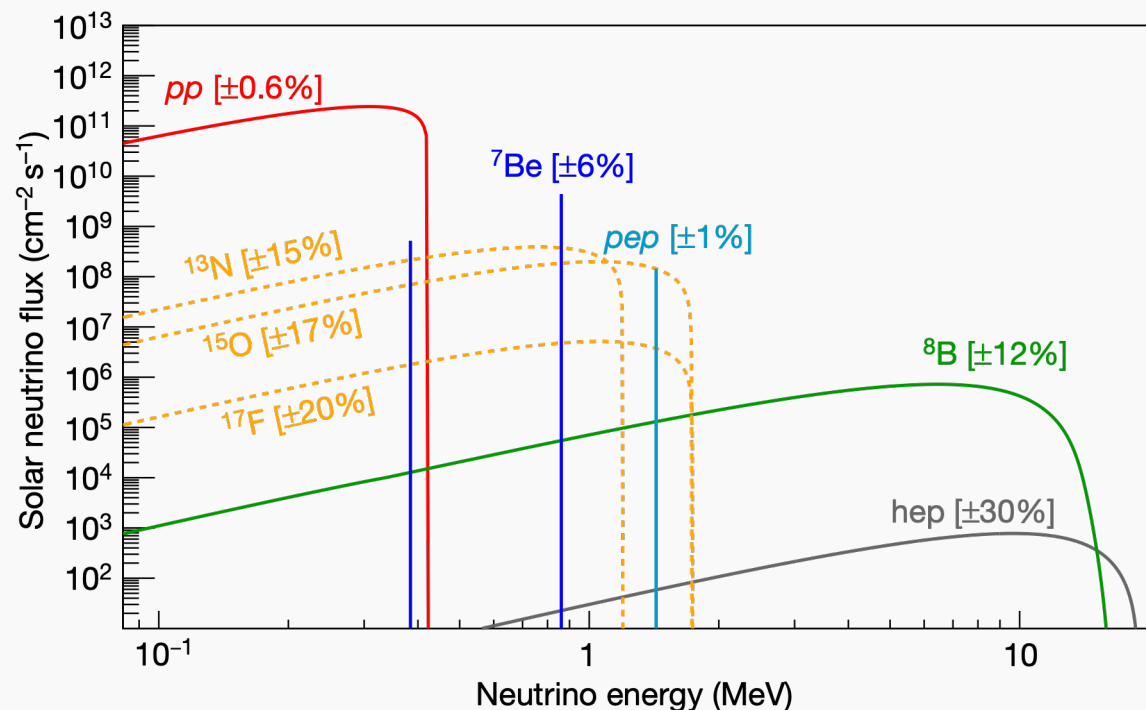



Solar pp neutrino scattering on electrons

- Leading result from Borexino with a recoil energy of >165 keV
- PandaX-4T: traditionally a DM detector, i.e. **low energy threshold**

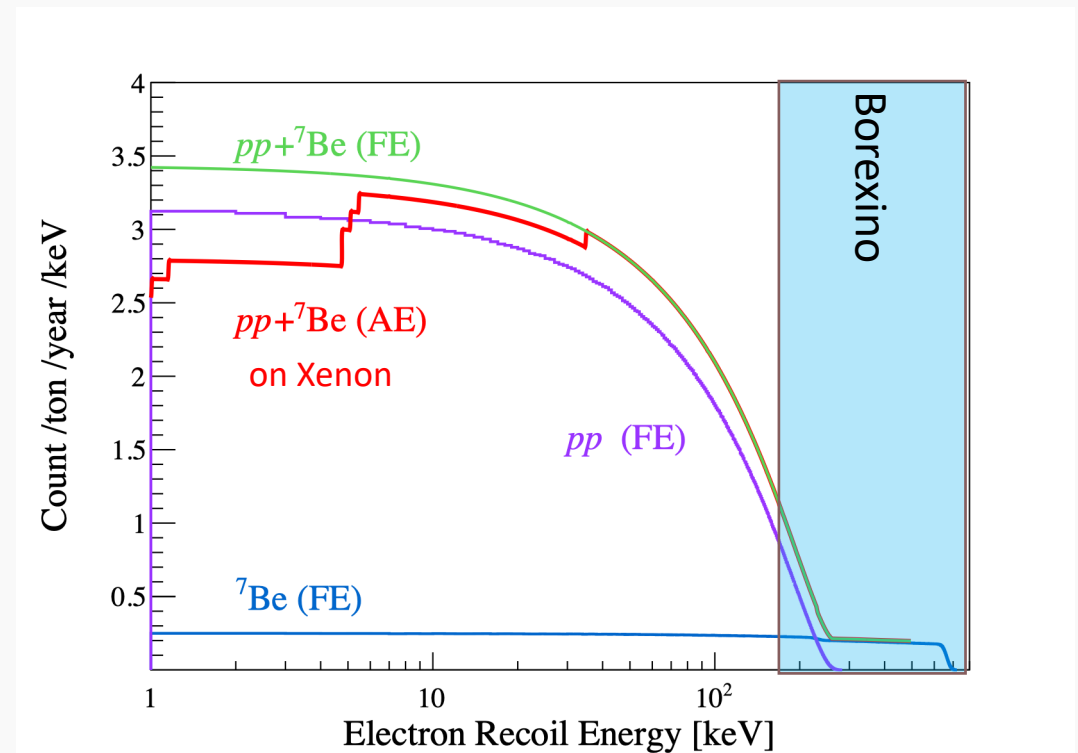
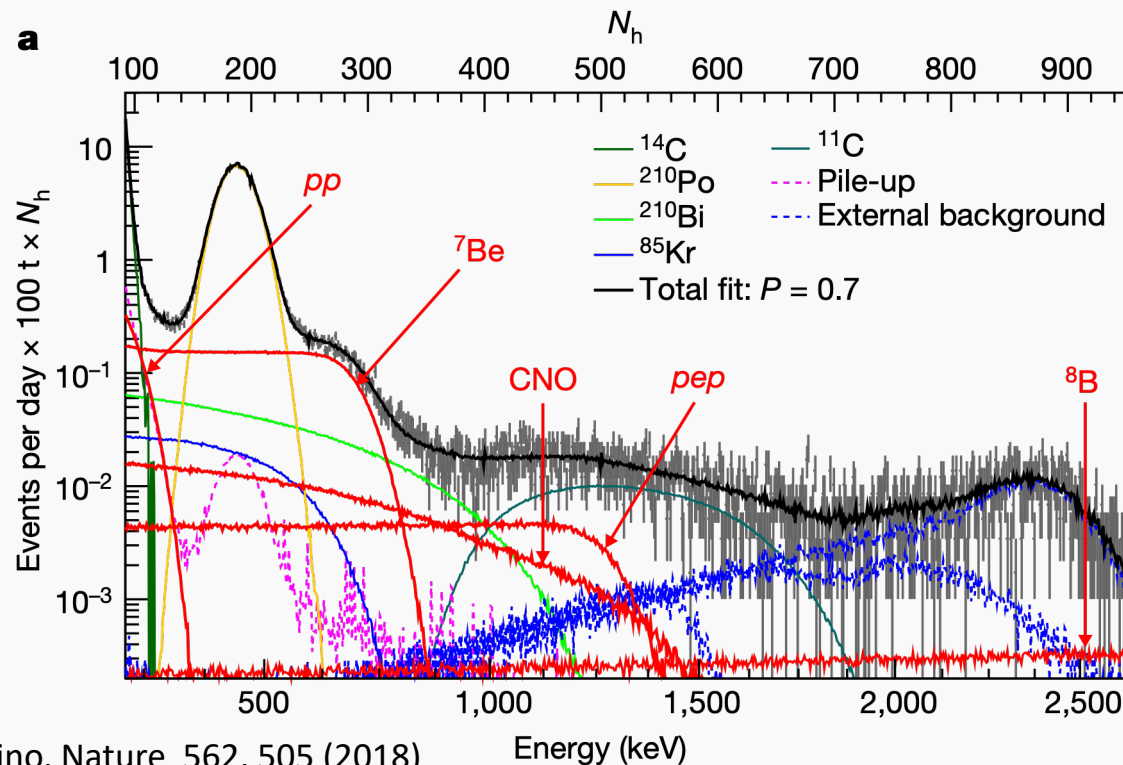



Solar pp neutrino scattering on electrons

- Leading result from Borexino with a recoil energy of >165 keV
- The first solar pp neutrino measurement in recoil energy from 24 to 144 keV with 0.63 ton \times year of PandaX-4T Run 0 exposure

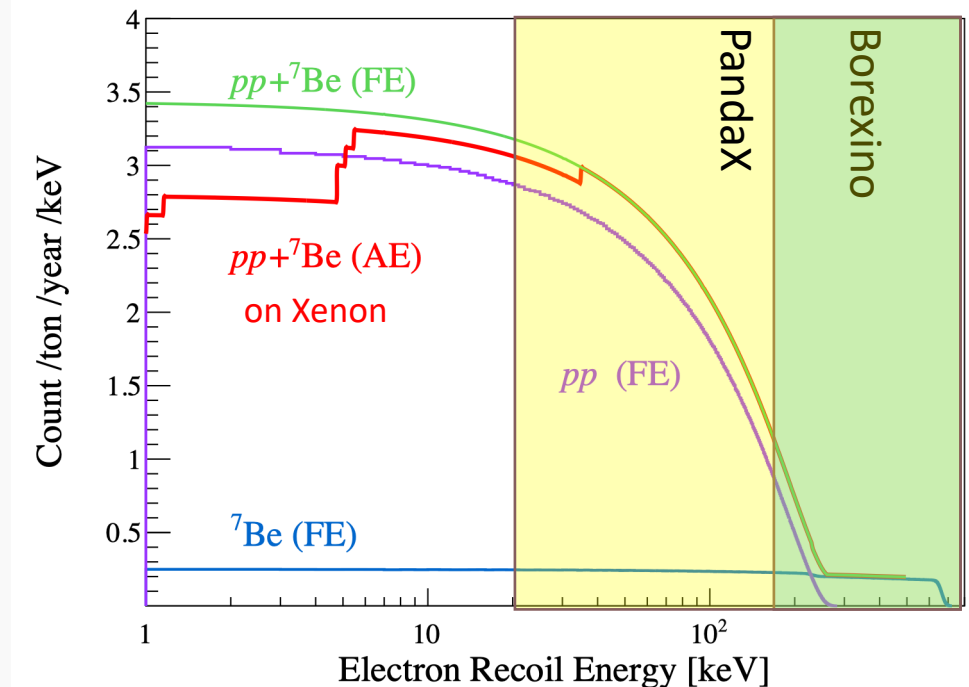
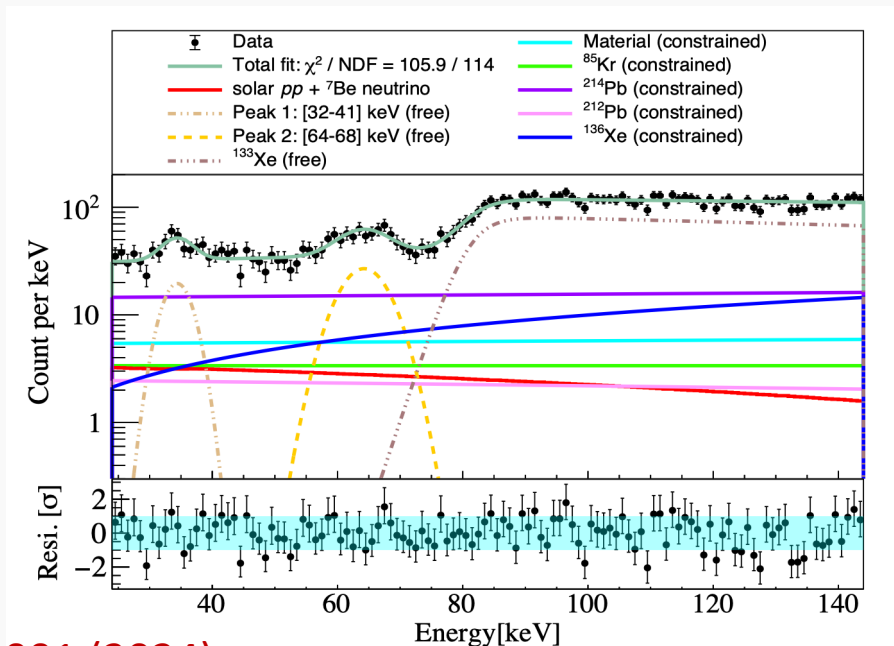



PandaX-4T Run 2 data: first release

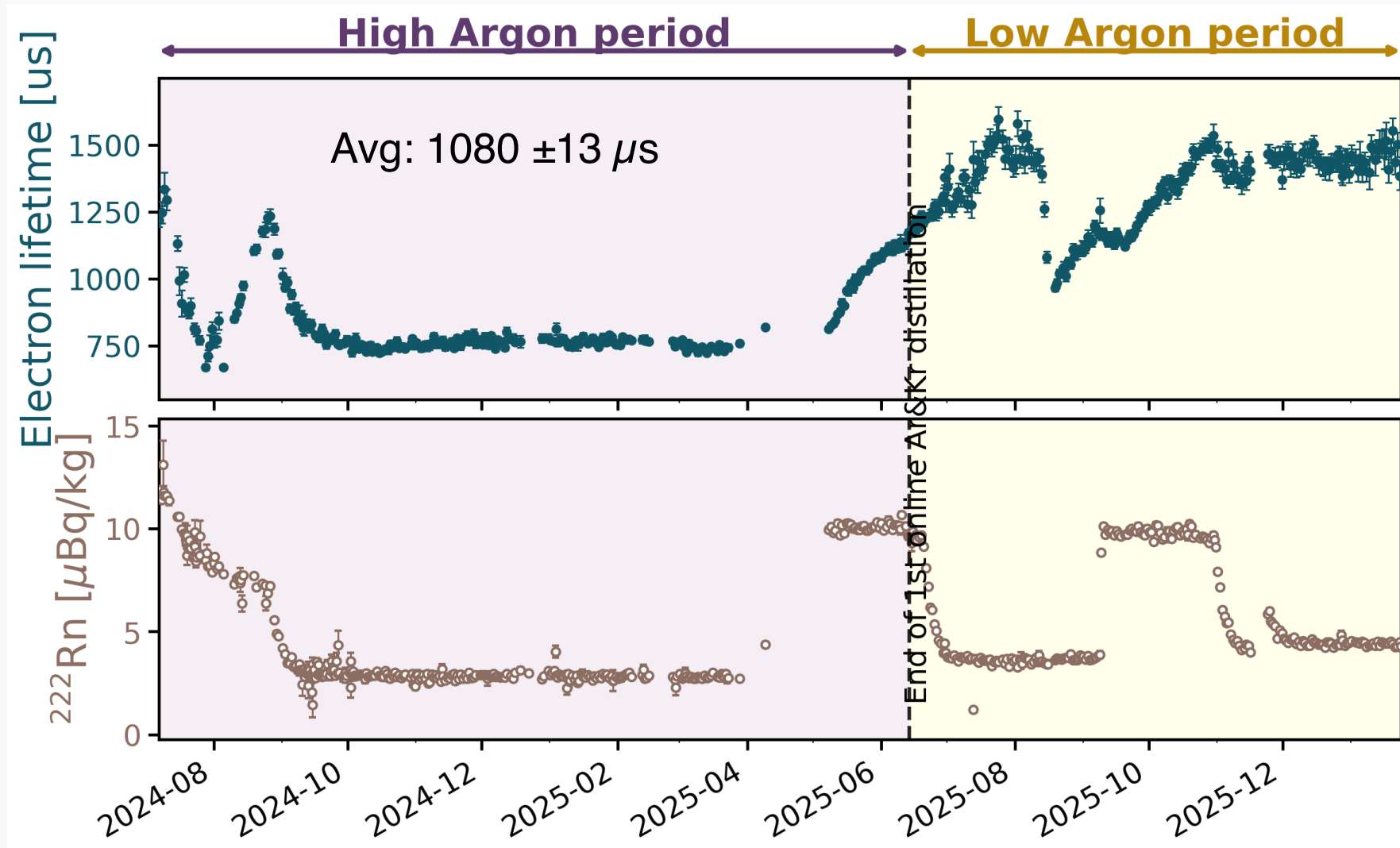
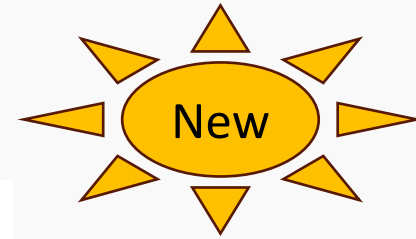



Kr/Ar online distillation

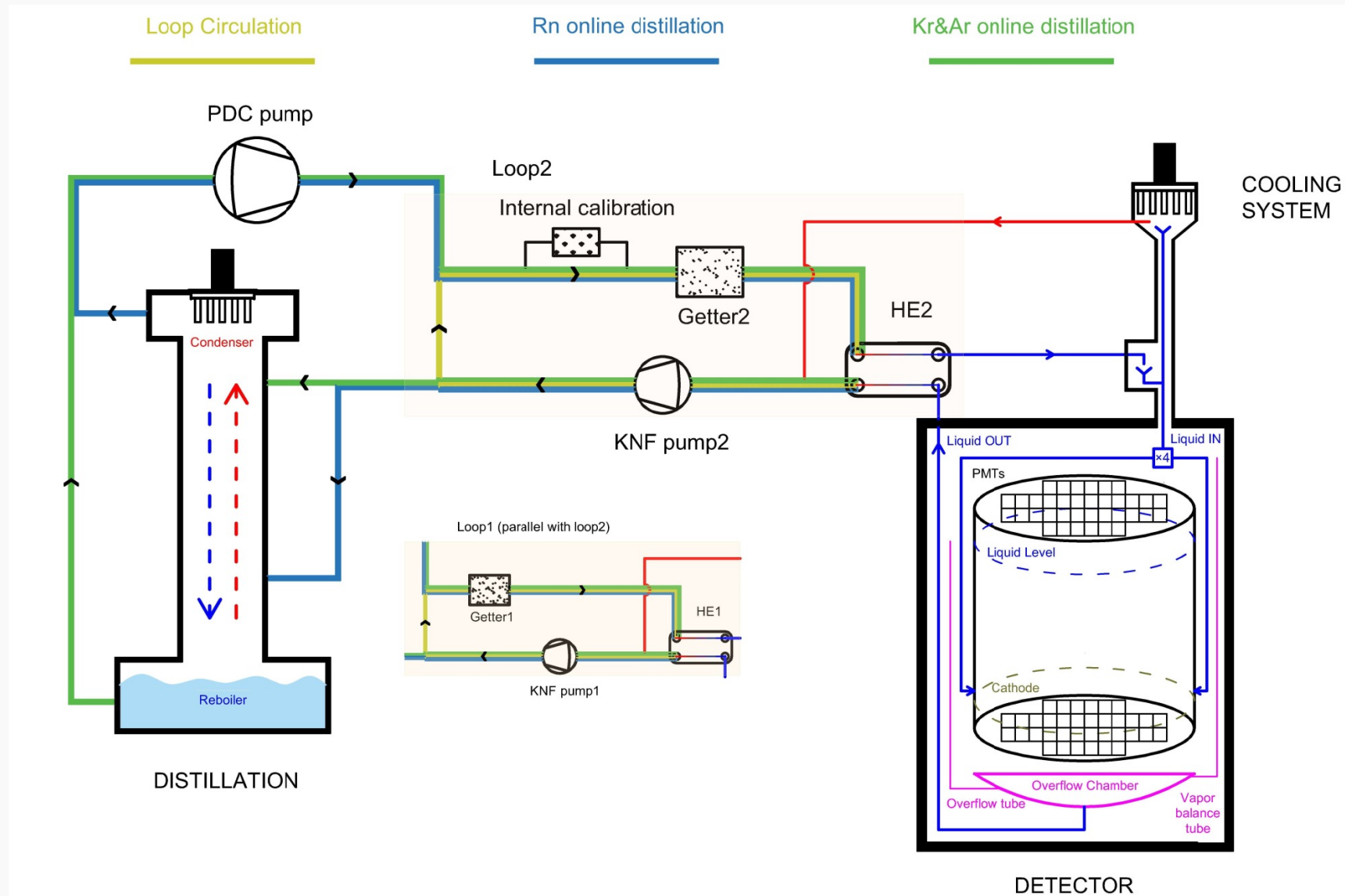



Kr/Ar online distillation

- Distillation tower in Kr/Ar mode: May-June and Sept.-Oct. 2025
- ^{39}Ar level: from $0.74 \mu\text{Bq/kg}$ to $0.10 \mu\text{Bq/kg}$ on average
- *In situ* Kr/Ar monitoring with a cold (enrichment) trap and RGA system

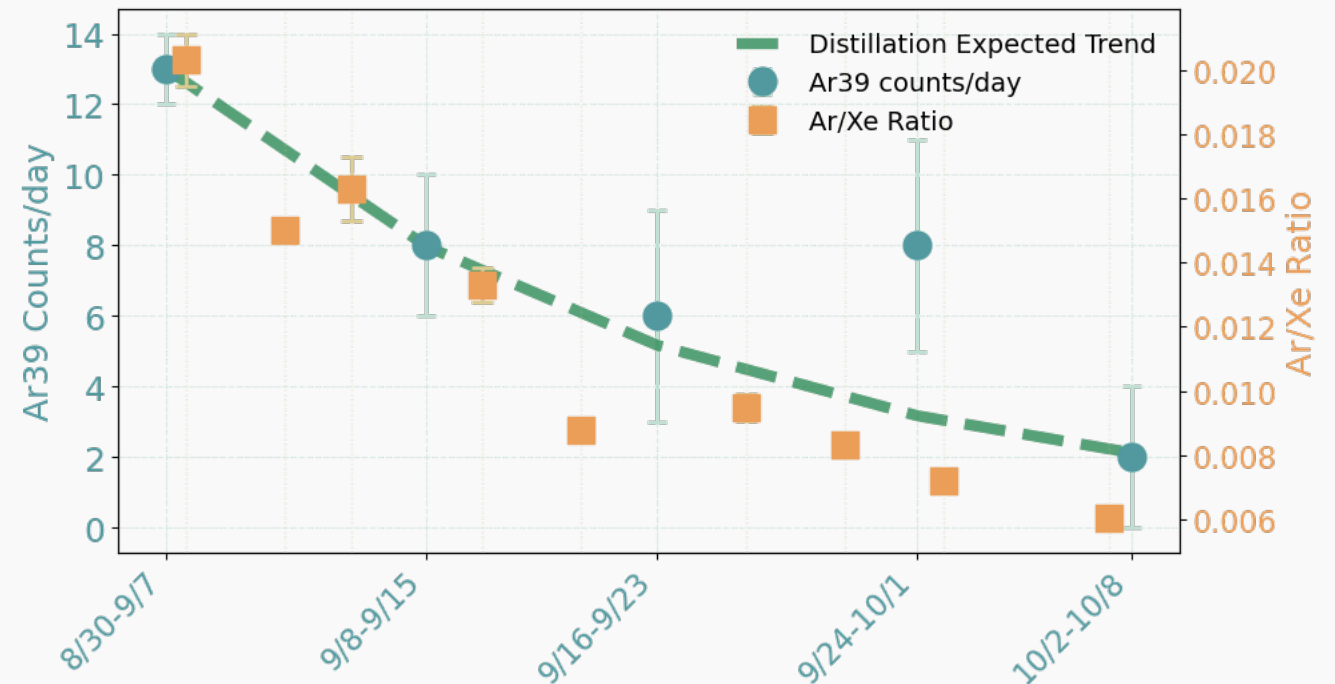
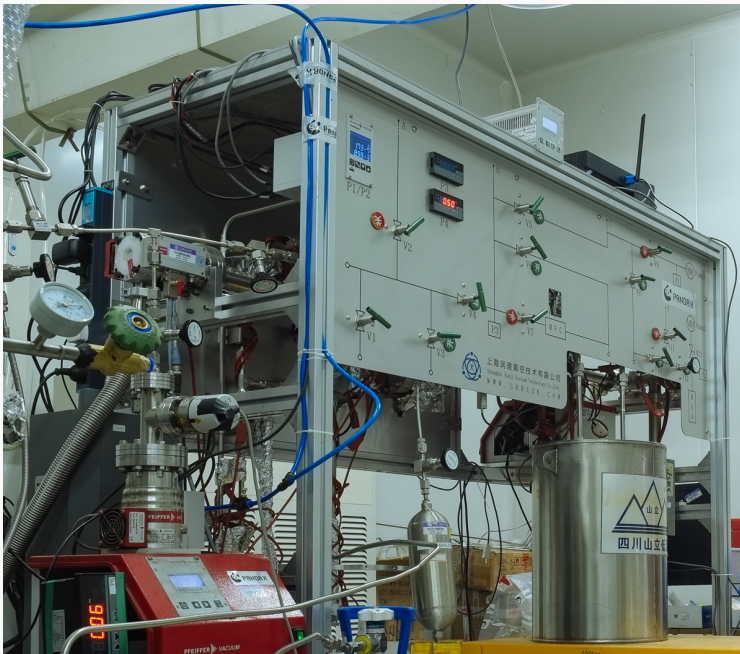



Background model

- External γ from detector materials: MS spectral fit for U/Th/K/Co
- Internal β : ^{39}Ar from assay monitoring; ^{85}Kr from delayed coincidences; $^{214,212}\text{Pb}$ from α -tagged decay-chain activity
- Xe^* nuclides: temporal evolution; ^{136}Xe $2\nu\beta\beta$: PandaX-4T measurement

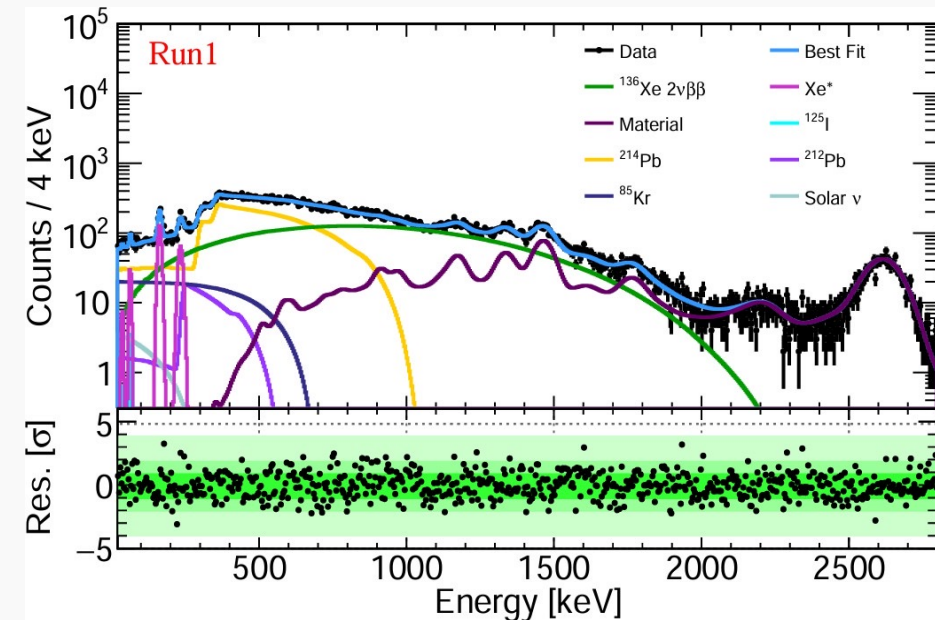
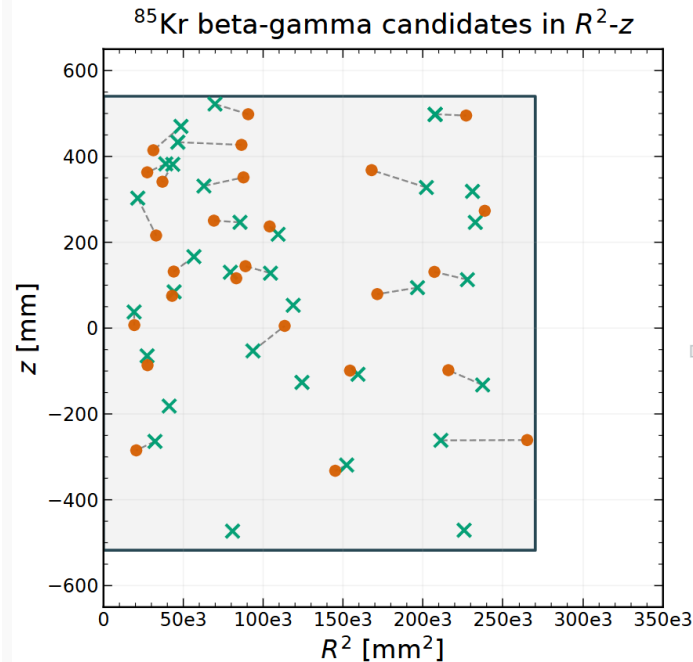
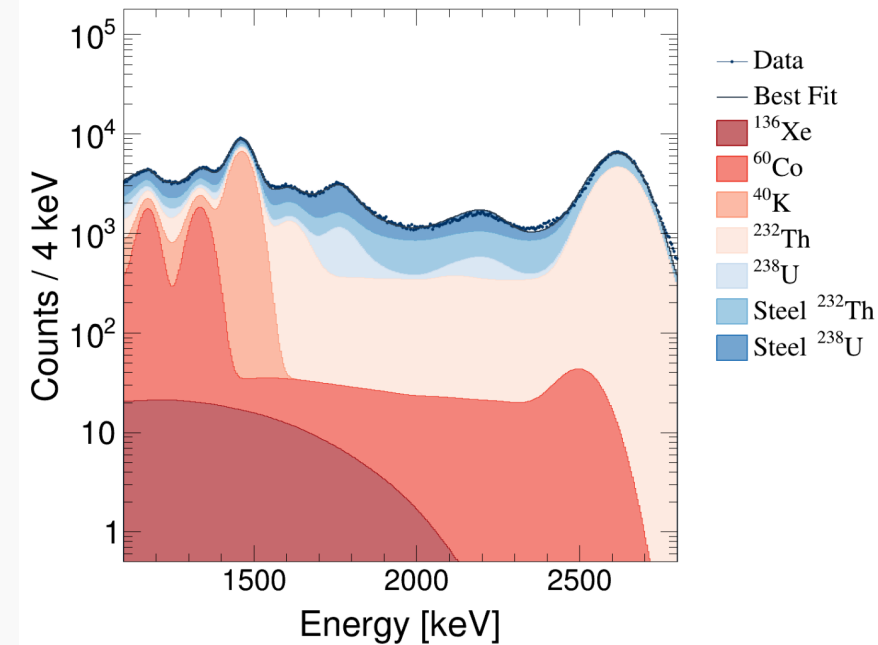



DAQ and data production

- New custom 14-bit, 500MS/s digitizers; new PMT bases
- Unified data production from keV to MeV
 - From PMT waveform to signal to event reconstruction

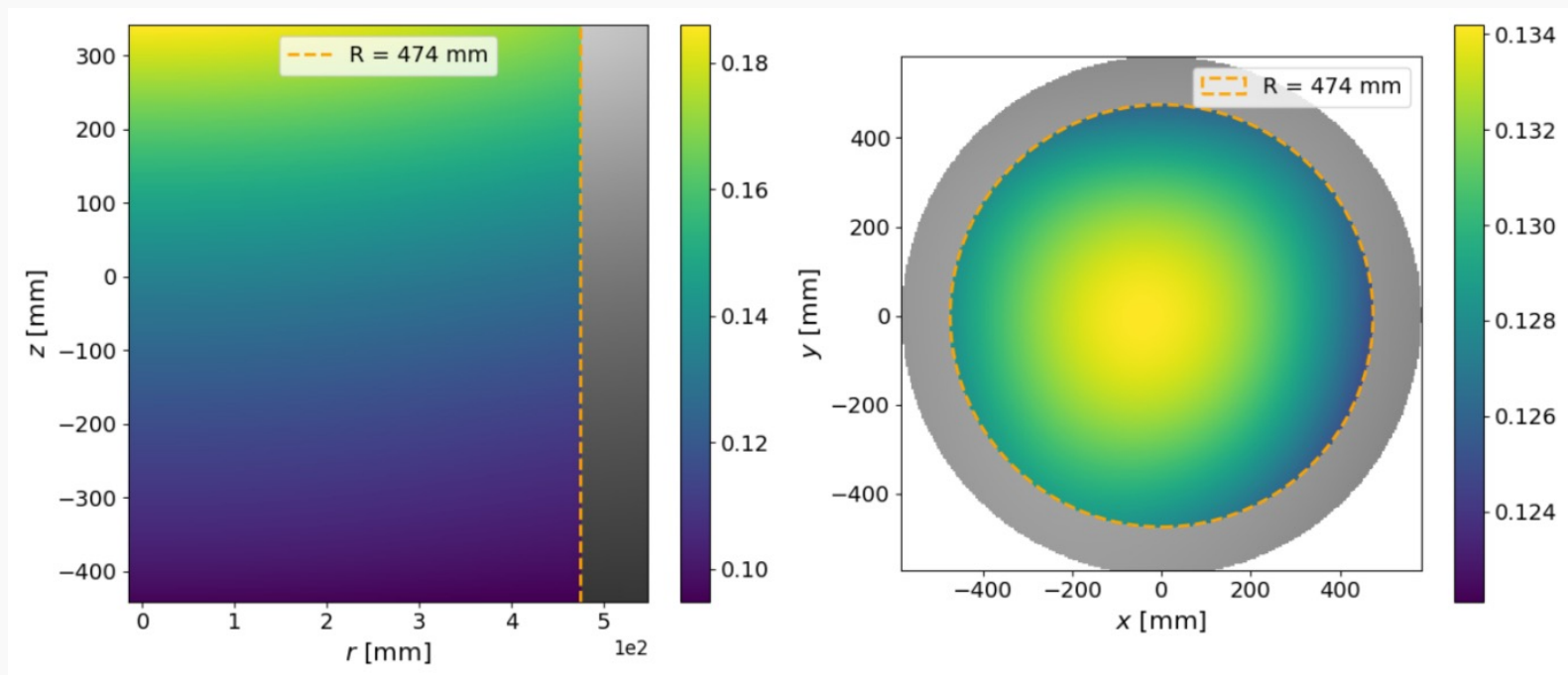

Mapping Correction

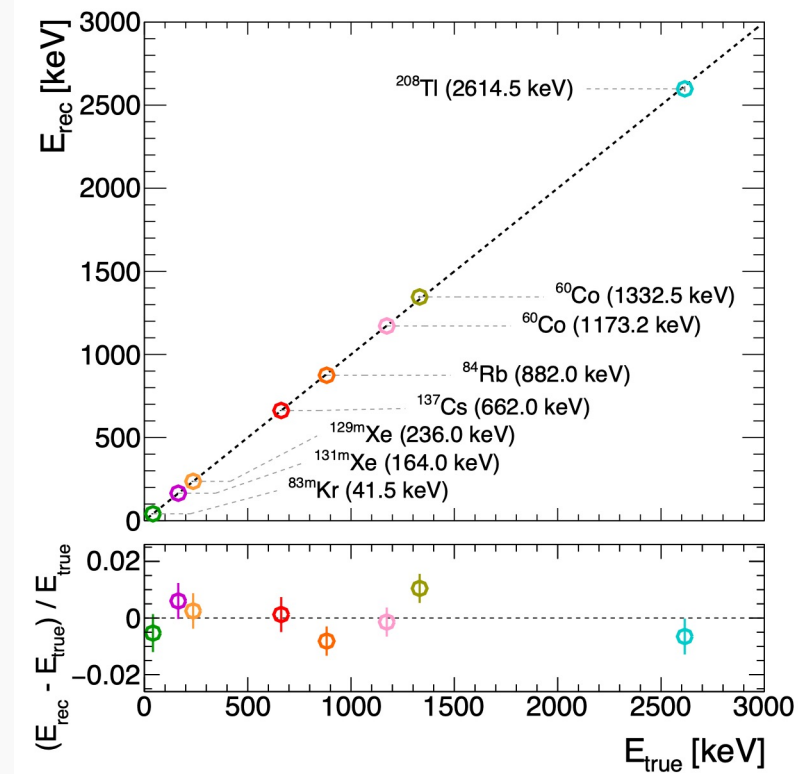



Blind analysis and unblinded fit

- Final unblinding after ROI/FV optimization and validation checks
- Simultaneous fit of the High Ar and Low Ar spectra in Run 2

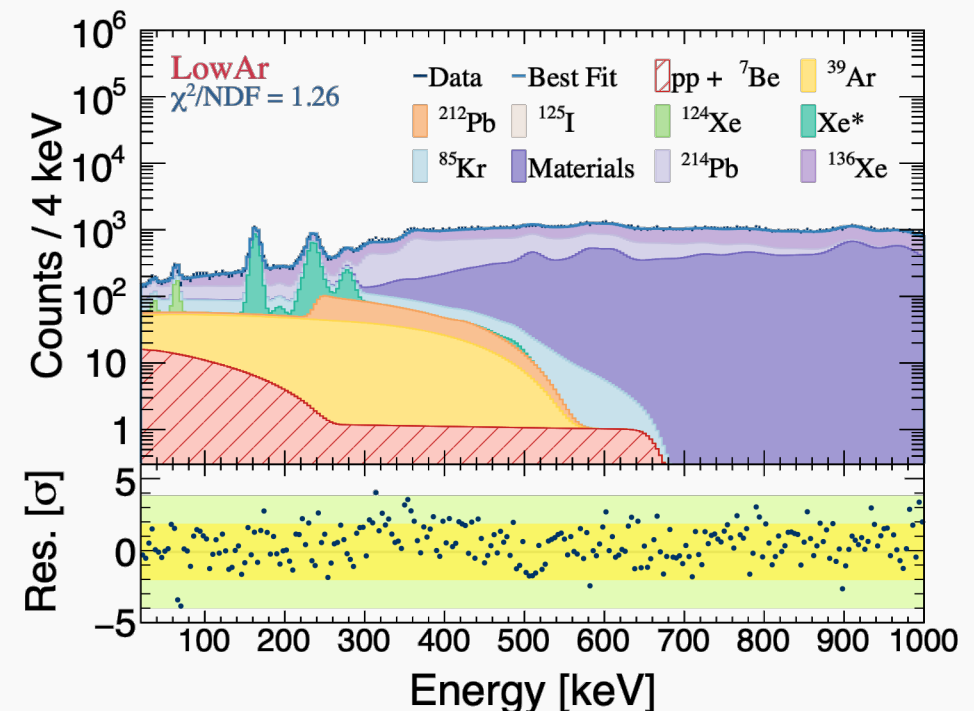
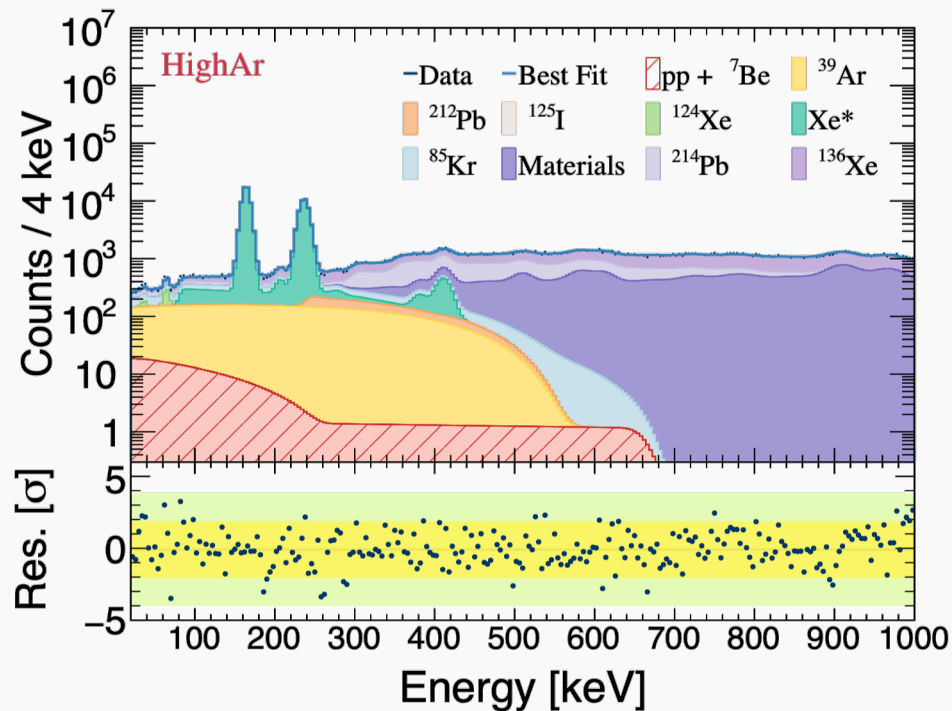
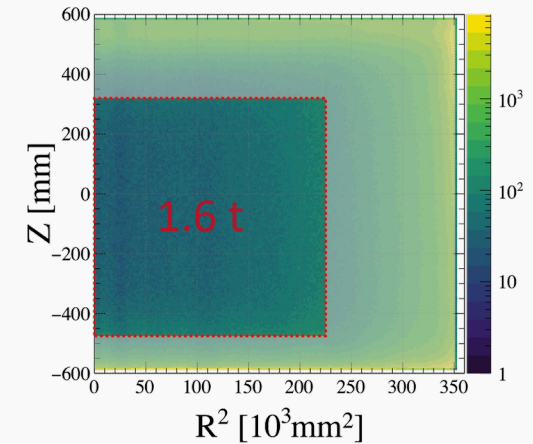



Preliminary Results

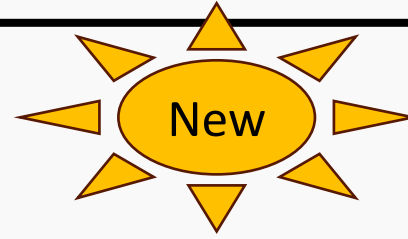

- Solar pp neutrino–electron scattering measured at recoil energy < 165 keV
- Consistent with Standard Solar Model prediction

PandaX PRELIMINARY

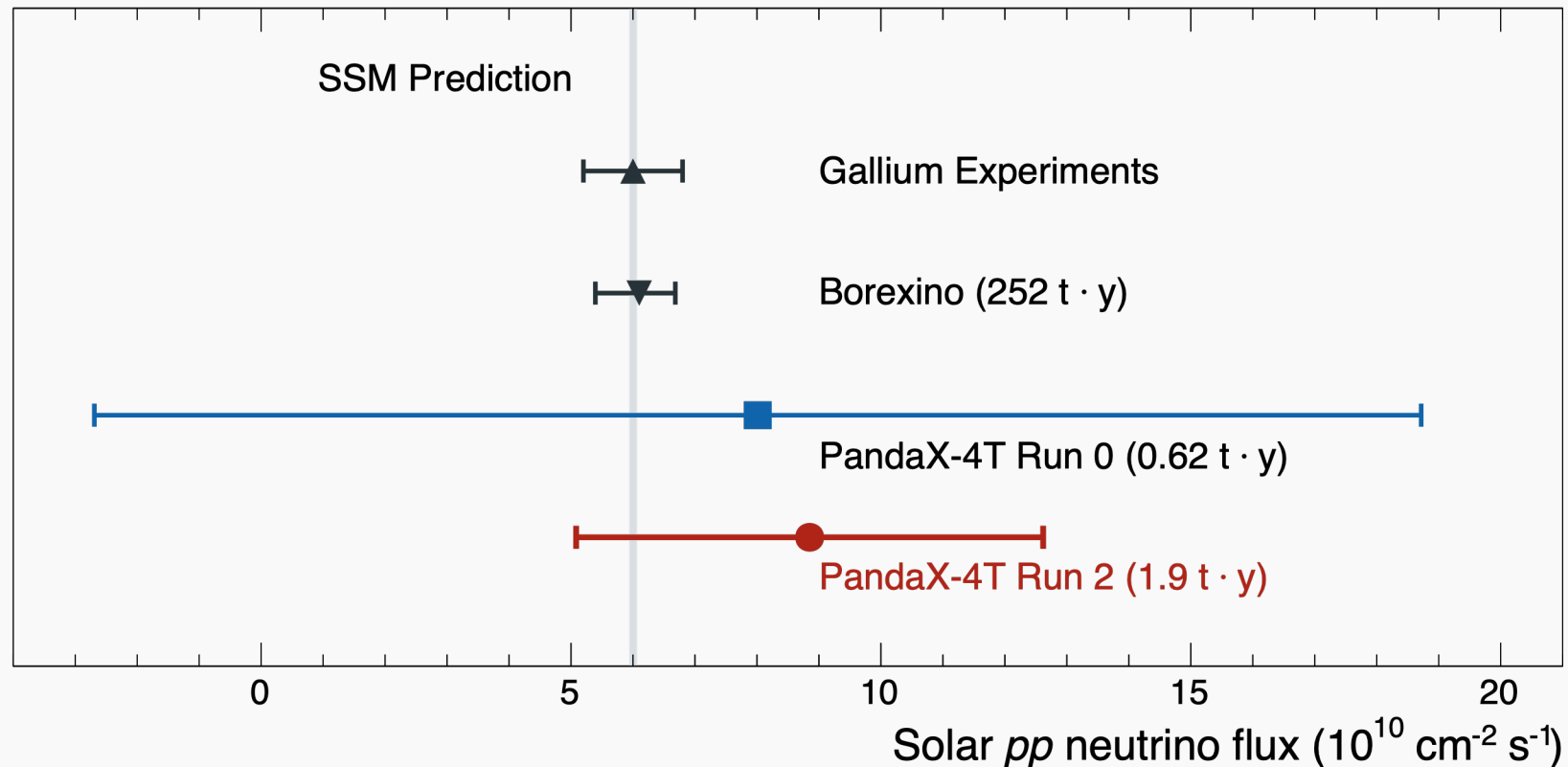

PRC 80, 015807 (2009)

Nature 562, 505 (2018)



Recent PandaX Neutrino results

^{136}Xe half life measurement

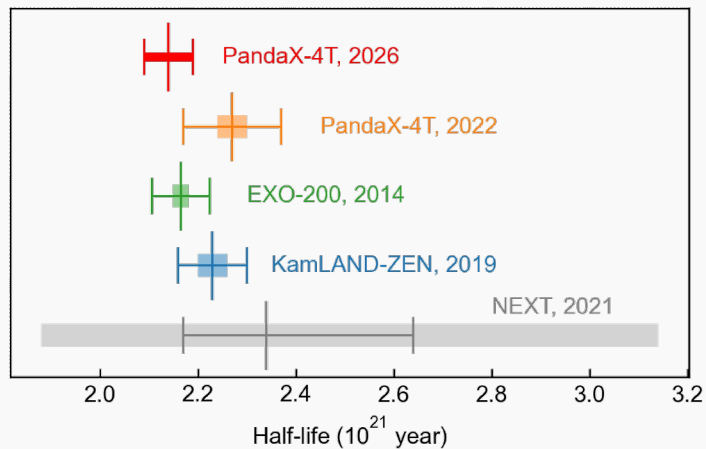

Effective Neutrino Majorana mass limit

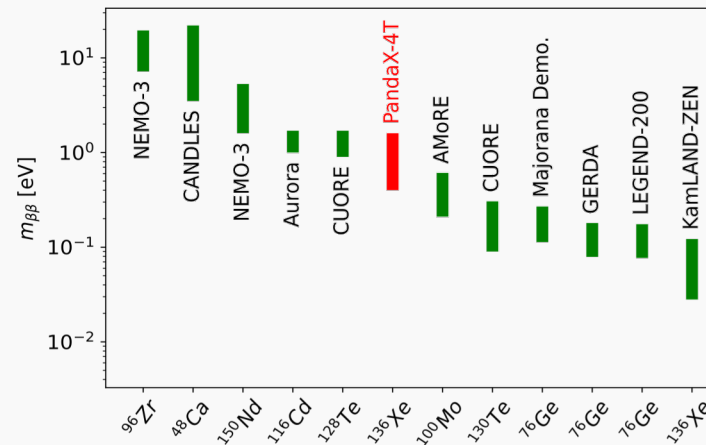

^{134}Xe half life limits

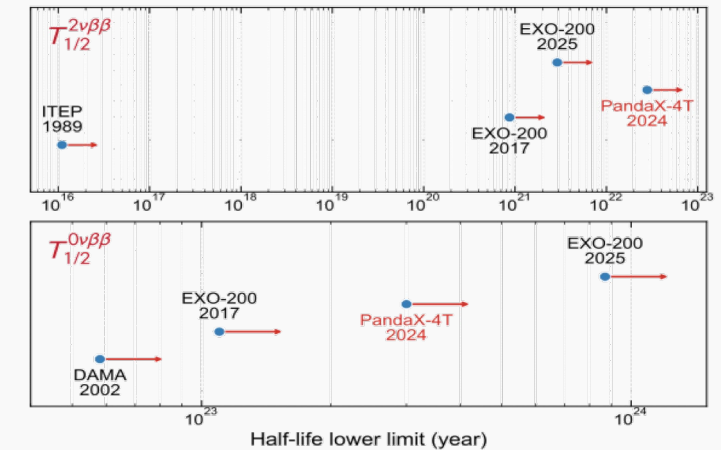

Solar ^8B neutrino flux measurement

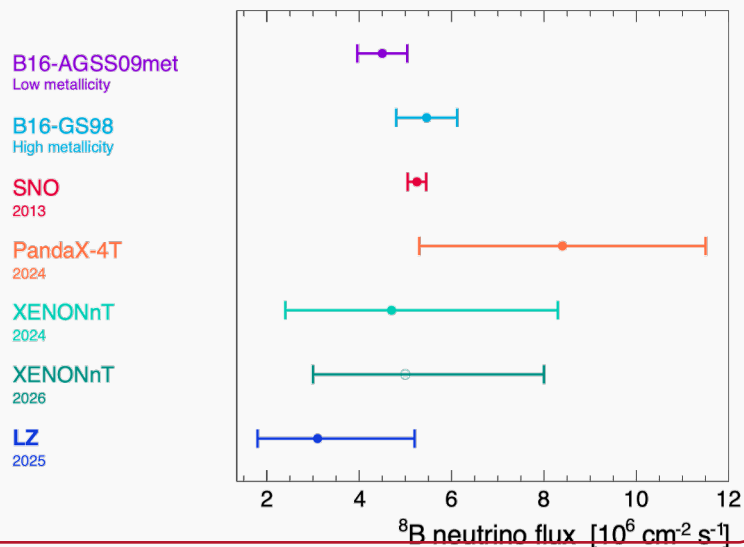

Solar pp neutrino flux measurement

PandaX PRELIMINARY

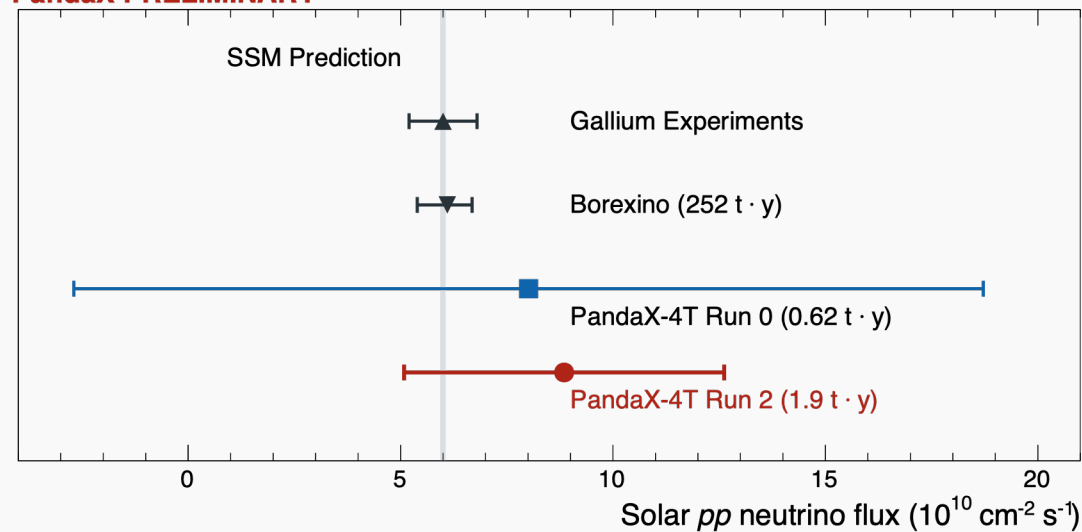

PandaX-4T
online
supernova
trigger with 6
min latency

(Chinese Phys.
Lett. 43 021103,
2026)

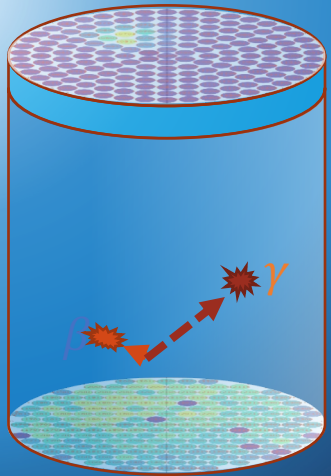

5D calorimeter

Event info

Physics

3D position

ER/NR

WIMP DM

Time

SS/MS

$0\nu\beta\beta$

Energy

Evolution

Solar ν

Fiducialization

Nuclear

Exotics

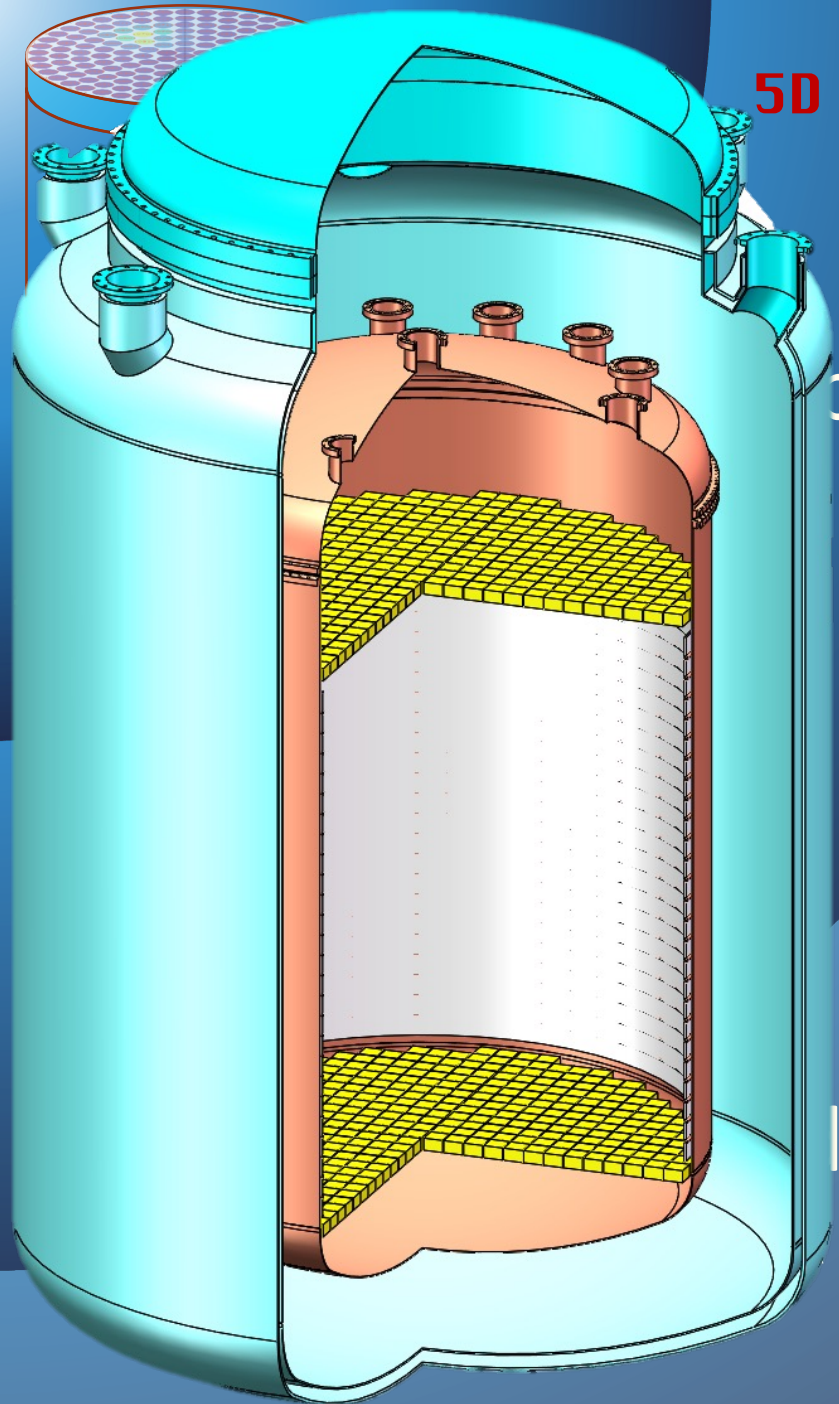

5D calorimeter

Event info

Physics

position

ER/NR

WIMP DM

SS/MS

$0\nu\beta\beta$

Evolution

Solar ν

miculazation

Nuclear

Exotics



Future experiment: PandaX-xT

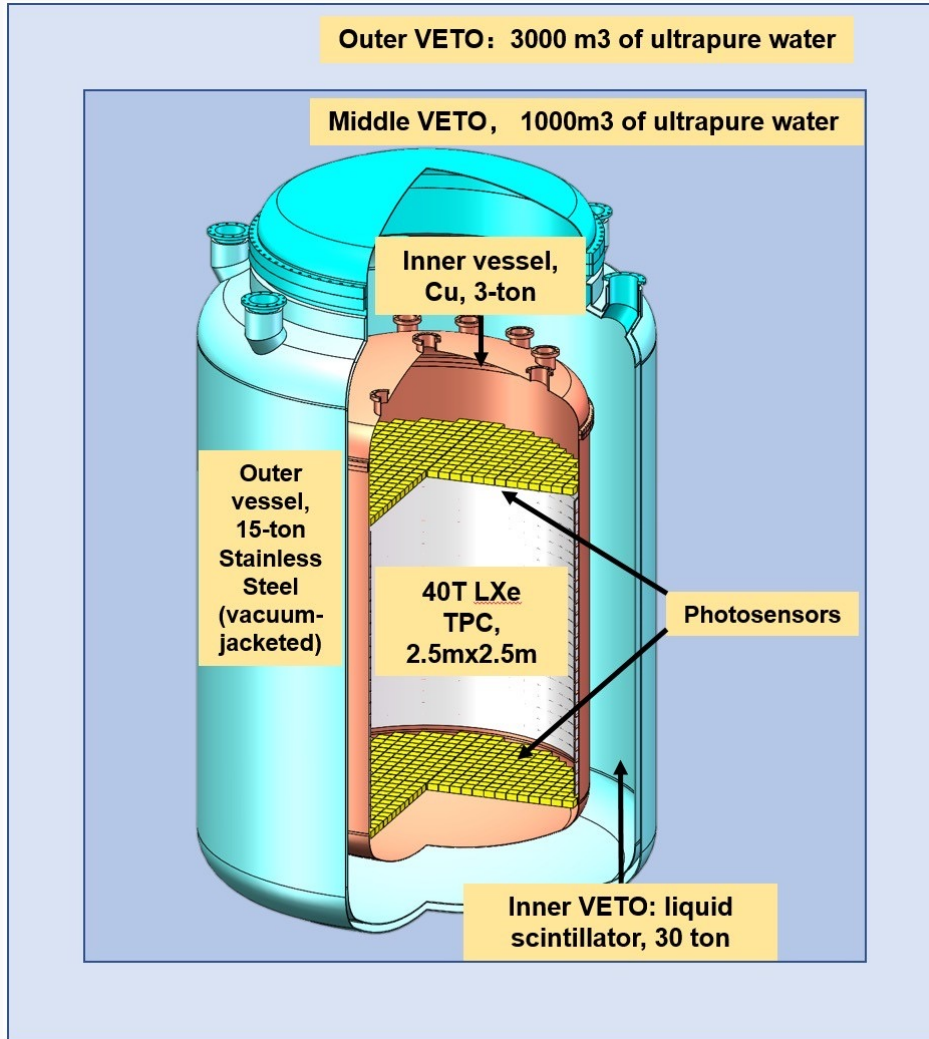

- 47-ton xenon, 40-ton sensitive volume
 - TPC 2.5m in diameter and 3m in height
 - High-granularity, low-background 2-in PMT array
 - Cold LS veto outside of Cu inner vessel
 - Staged and upgradable
- First stage is PandaX-20T



PandaX-xT for $0\nu\beta\beta$

- 4 ton of ^{136}Xe for $0\nu\beta\beta$
- Effective self-shielding: Xenon-related background dominates in the 8.4-tonne center FV

	Baseline (1/tonne/year)	Ideal (1/tonne/year)
Photosensors	1.4×10^{-2}	2.8×10^{-3}
Copper vessel	3.2×10^{-2}	6.3×10^{-3}
^{222}Rn	4.5×10^{-2}	-
^{136}Xe DBD	5.2×10^{-4}	5.2×10^{-4}
^{137}Xe	8.7×10^{-4}	8.7×10^{-4}
Solar ^8B ν	1.4×10^{-2}	1.4×10^{-2}
Total	1.1×10^{-1}	2.4×10^{-2}

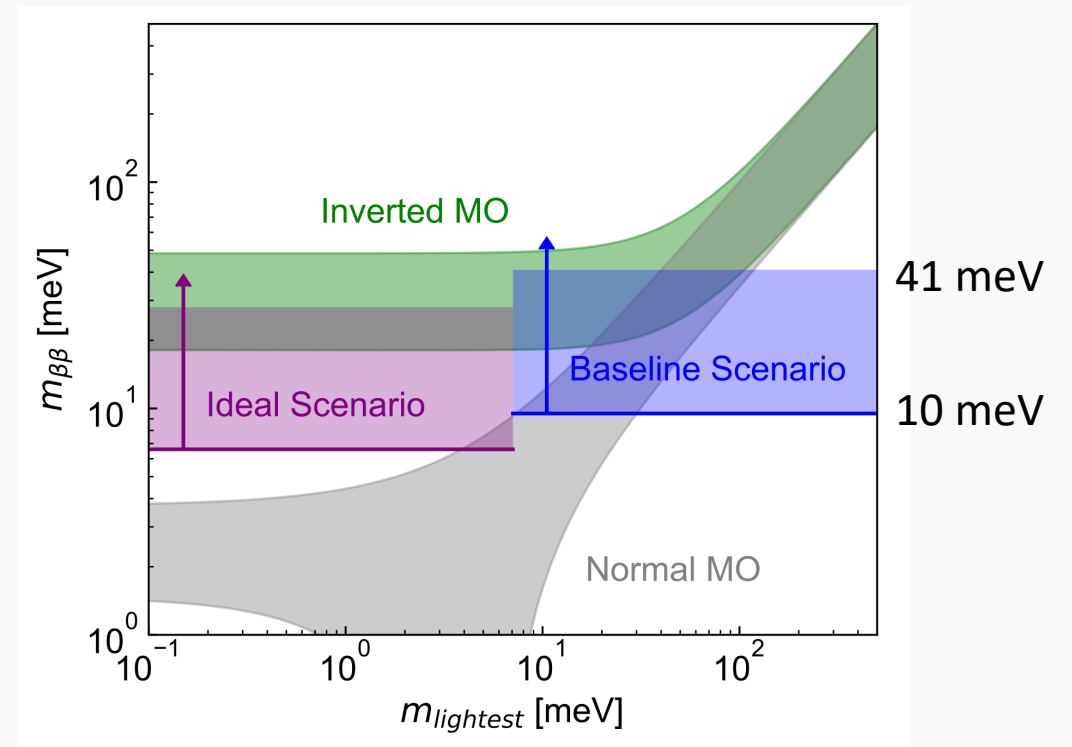
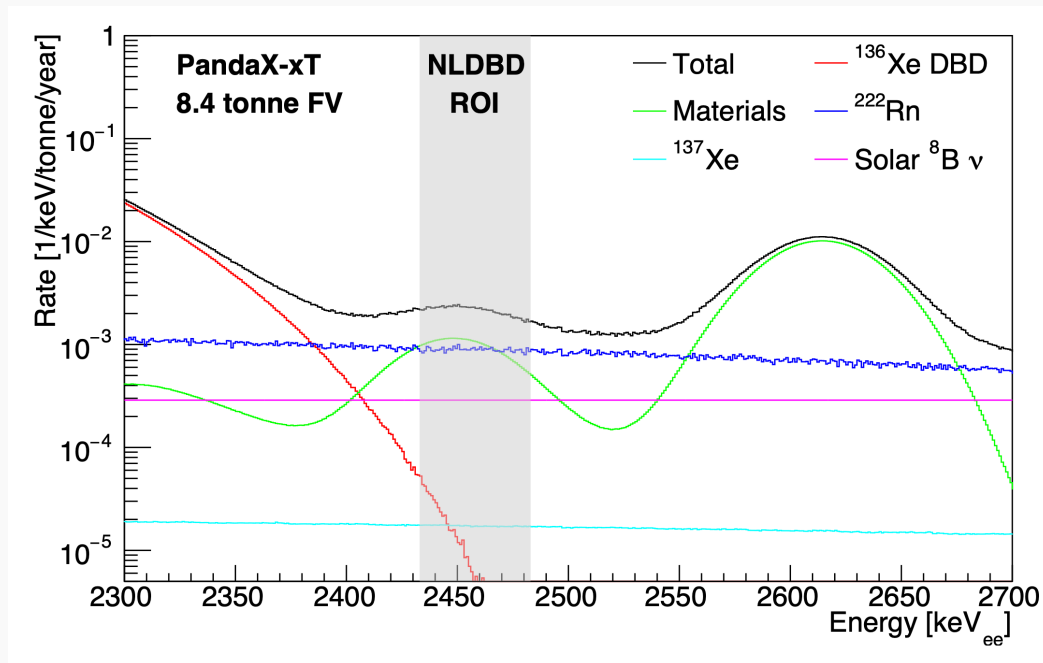



PandaX-xT for solar neutrino

^8B neutrino: from indication
to precision measurement

pp neutrino: competitive precision
with low energy advantage

Neutrino magnetic moments: better
than astrophysical observations

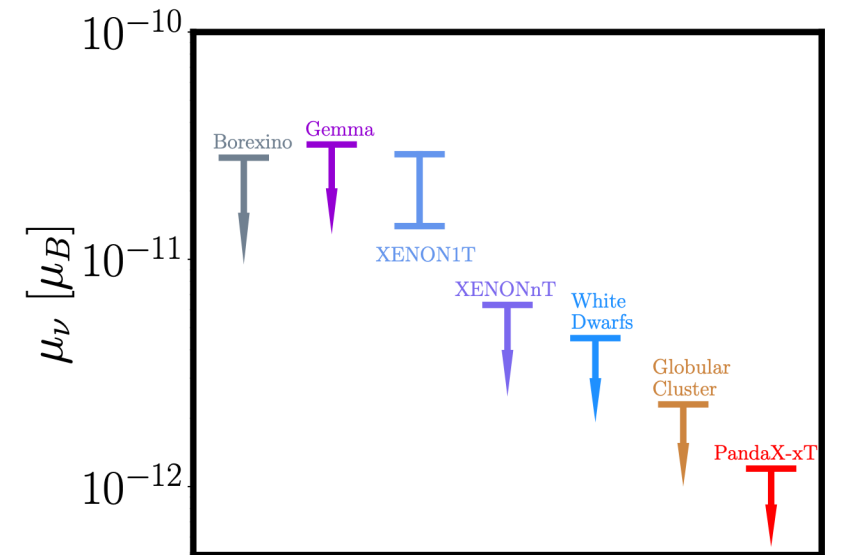
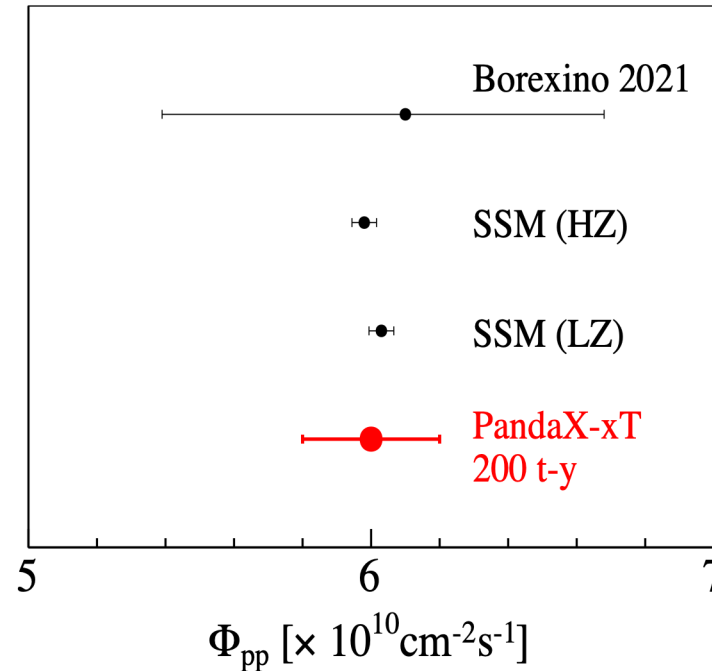
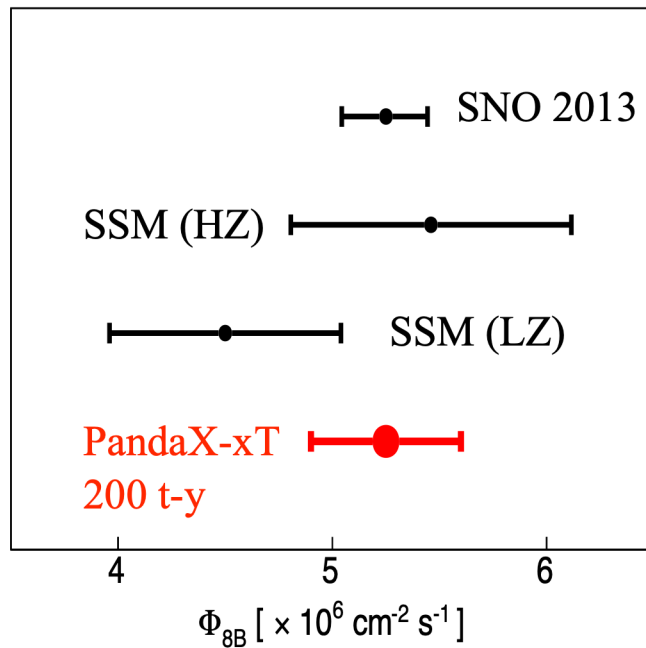



PandaX-xT Project Timeline

22

23

24

25

26

27

28

29

30

31

32

33

34

35

36

37

38

39

40

41

42

R&D; PandaX-4T Operation

Staged Xe procurement and detector upgrades with high live-time

Phase-I

20T

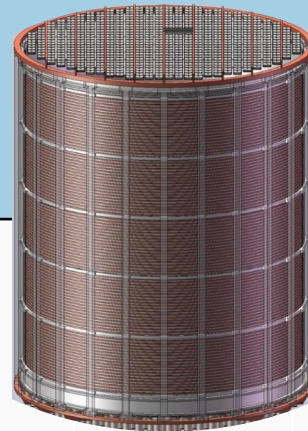

43T

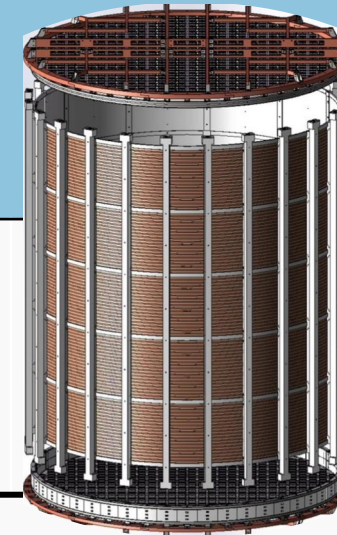

Isotopically separated xenon

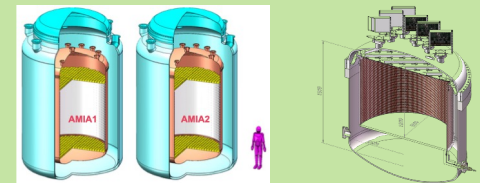

Phase-II



PandaX-xT infrastructure

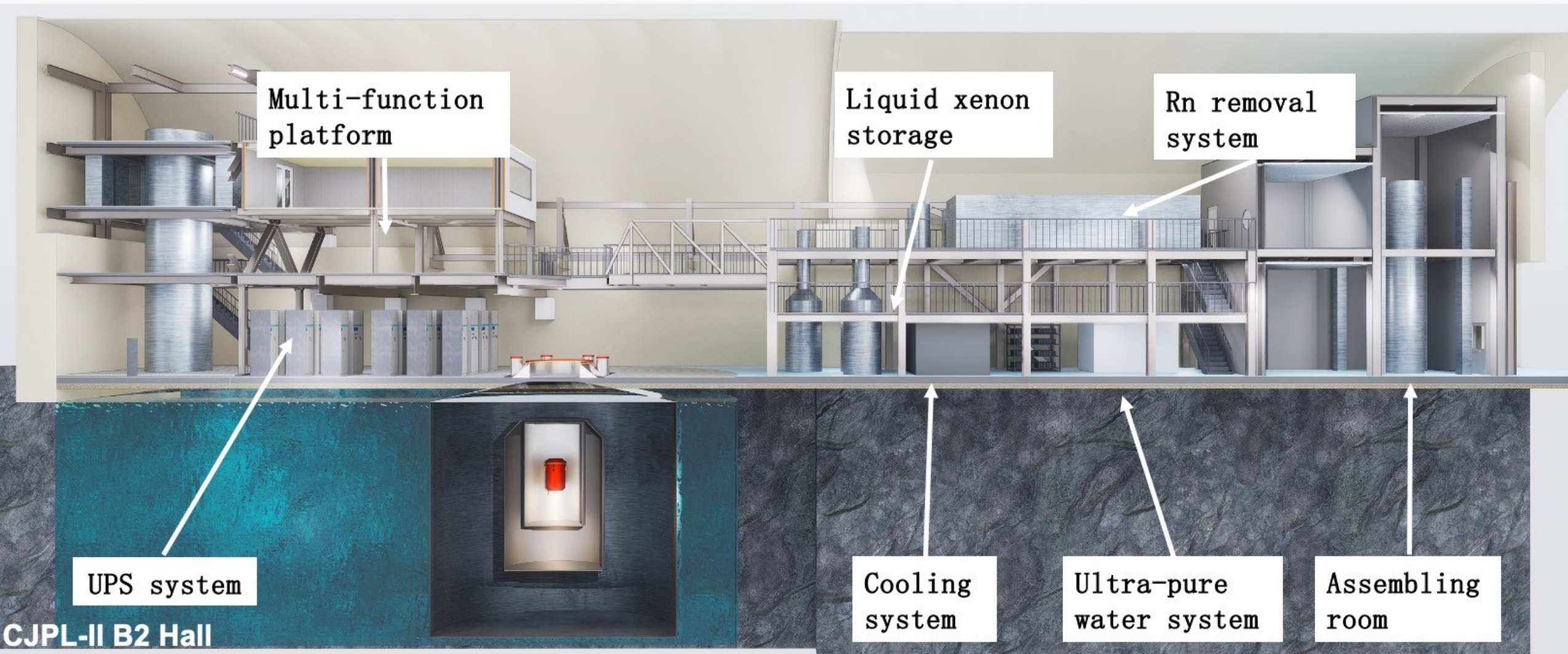



Transporting xenon to CJPL





PandaX-20T TPC

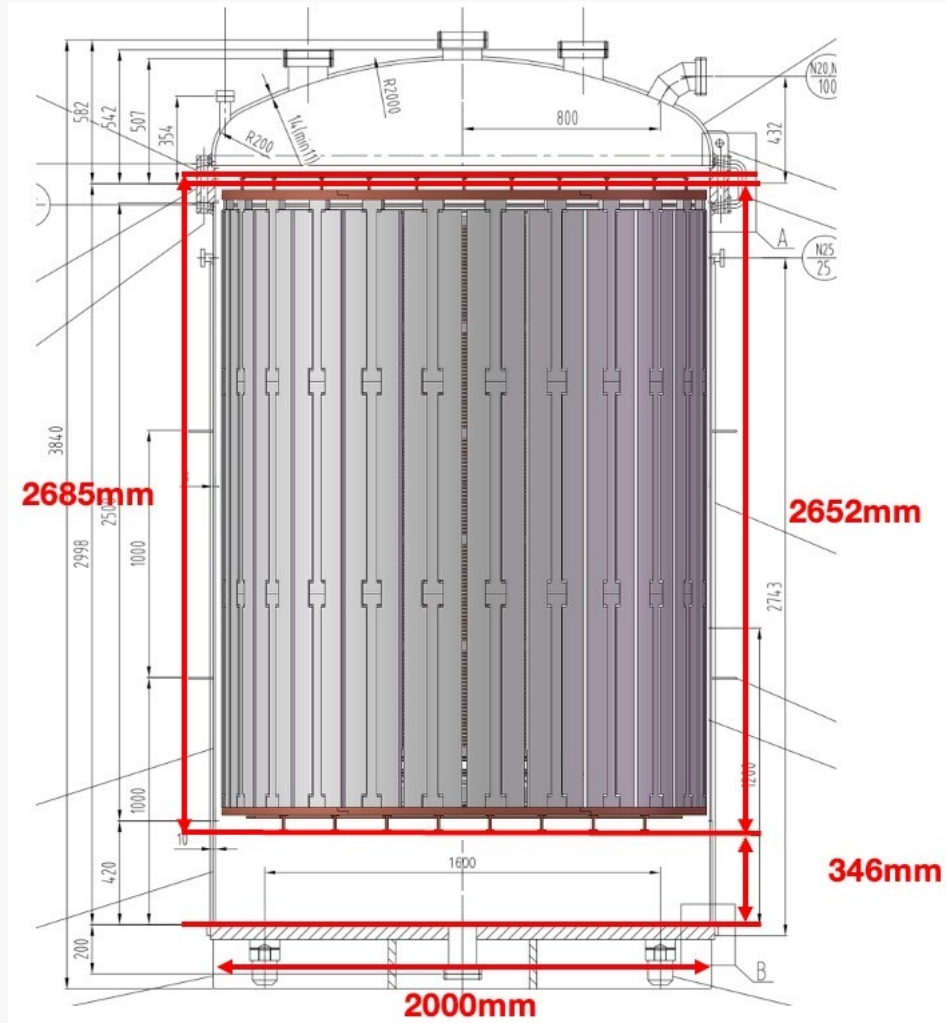

17 ton sensitive mass





Field cage and prototype tests

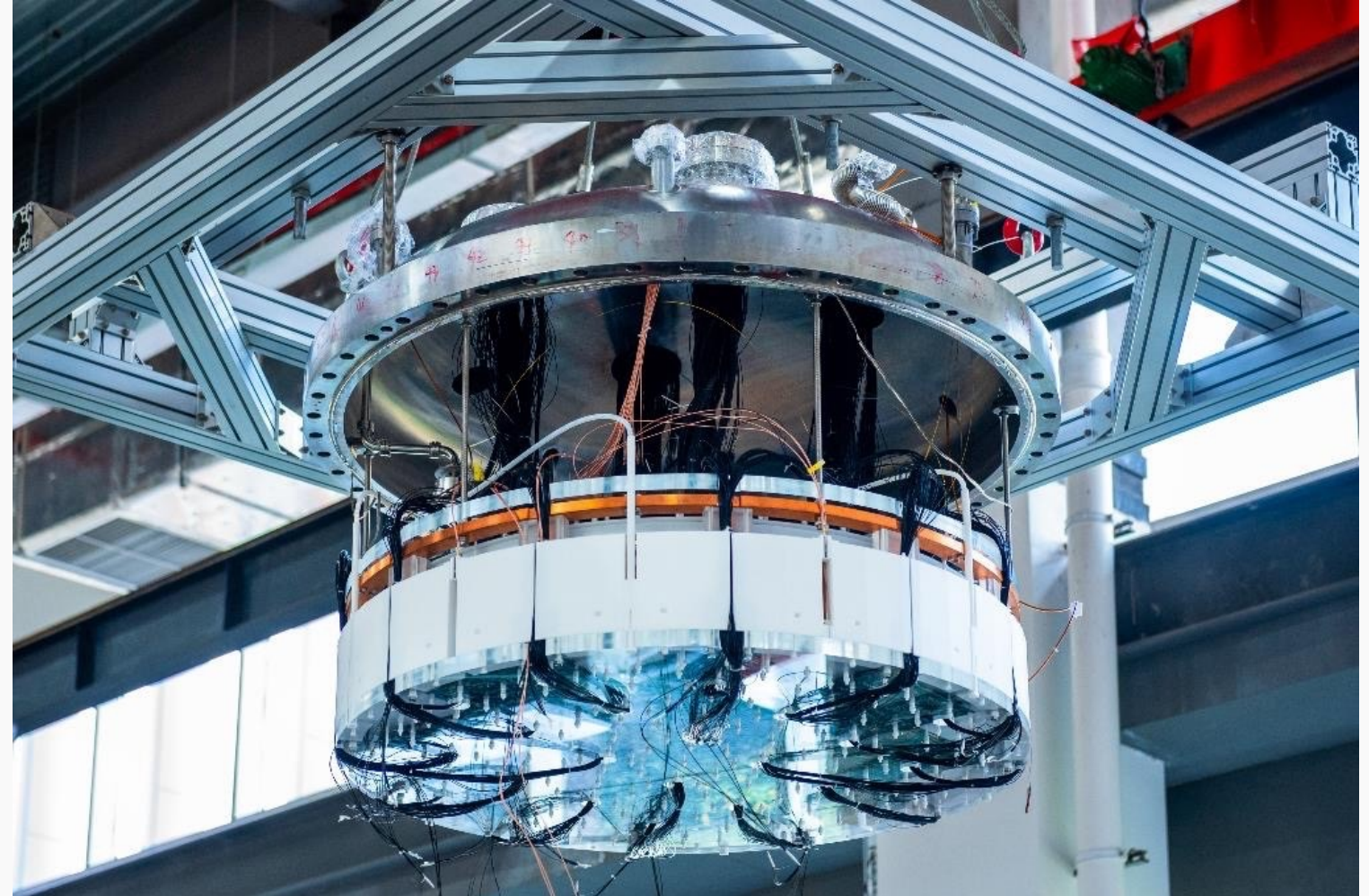
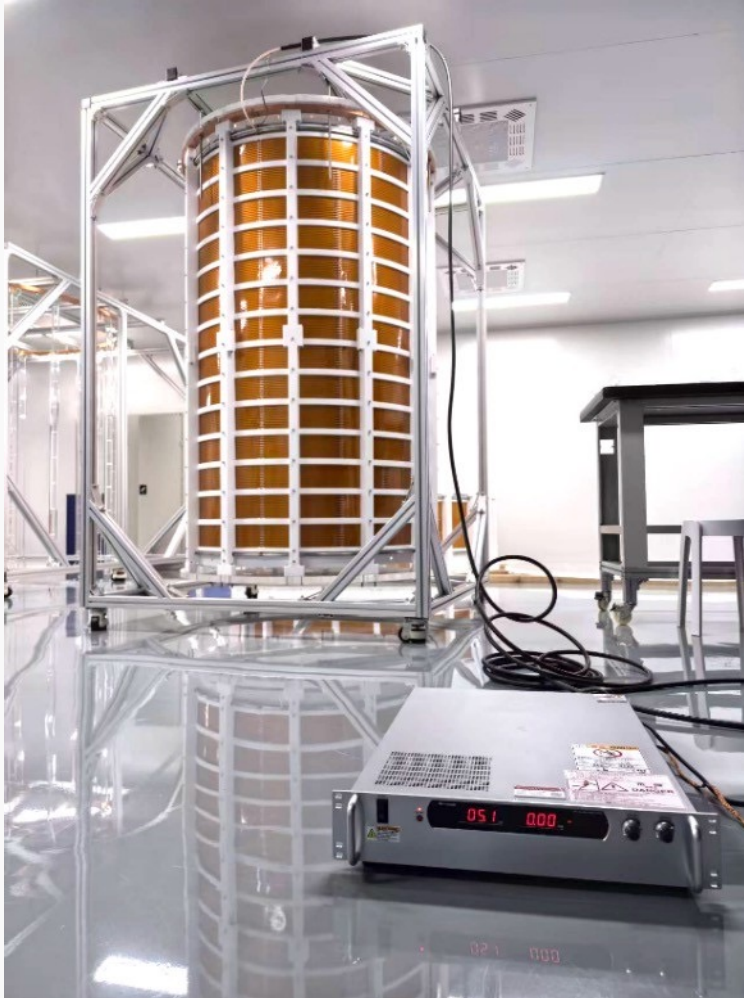



New 2" multi-anode R12699 PMT for LXe TPC

- Higher granularity while maintaining low dark noise: best of both large PMT and SiPM
 - Improved position reconstruction for better event topology
 - 2" array has an effectively wider dynamic range for DM and DBD simultaneously
- Collaboration between PandaX and Hamamatsu for a low-radioactivity version of R12699

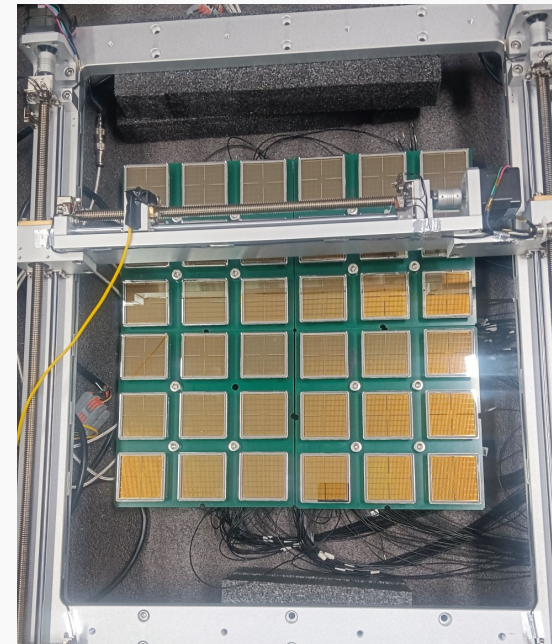
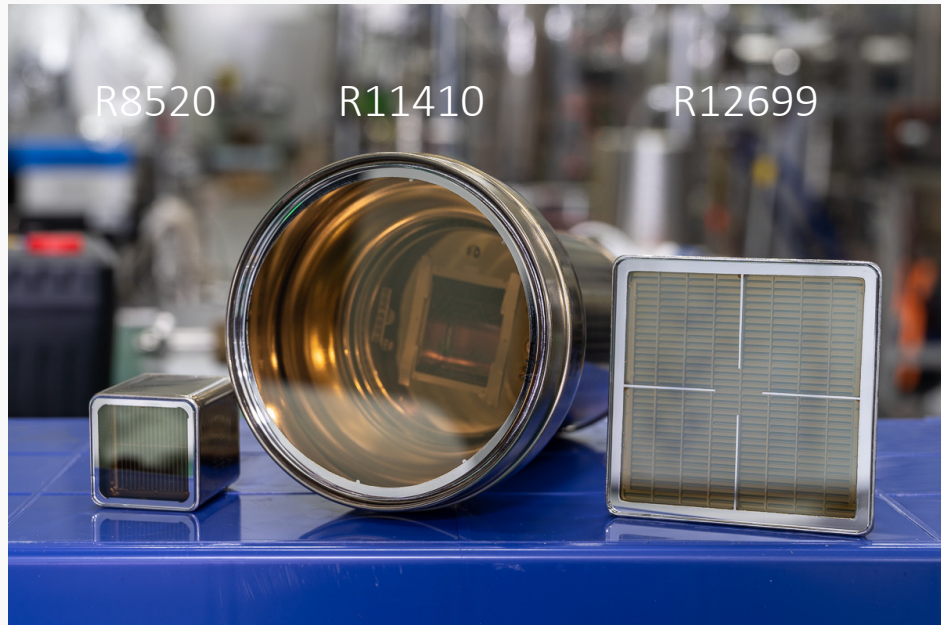

2" PMT Array
Base side: 70 mm
PMT side: 56 mm
Active side: 48.5 mm
Coverage: 48%
3" Coverage: 45%

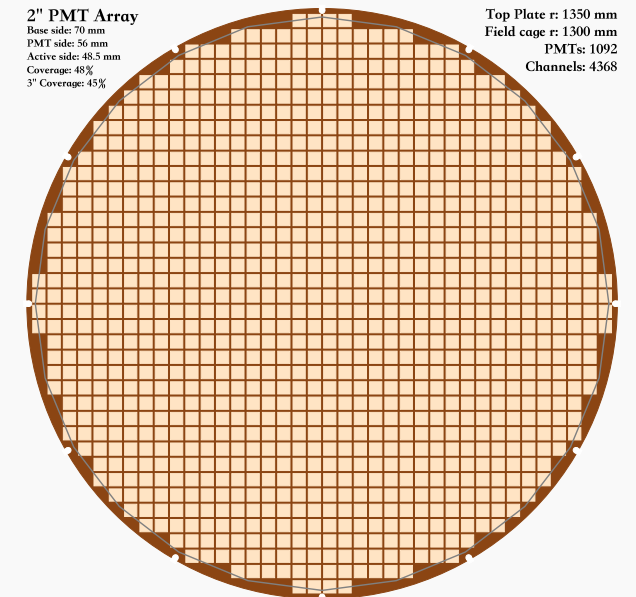

Conceptual array for a PandaX-xT



PMT system

- Top PMT array
 - 616 2inch multi-anode PMTs (R12699)
 - Low-radioactivity version to be delivered in 2026
 - Flexible-Rigid PCB (FRP) boards for integrated HV/signal readout lines with base
- Bottom PMT array
 - 433 3inch PMTs (PandaX-II and PandaX-4T)
 - Flexible PCB bases
- Assembly and system-level testing in progress

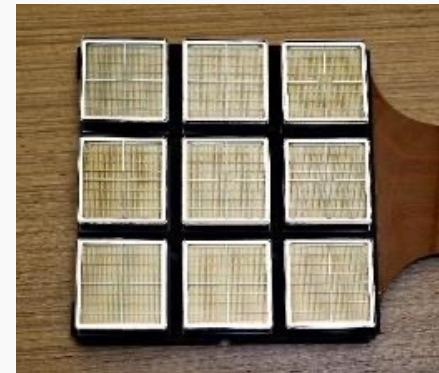
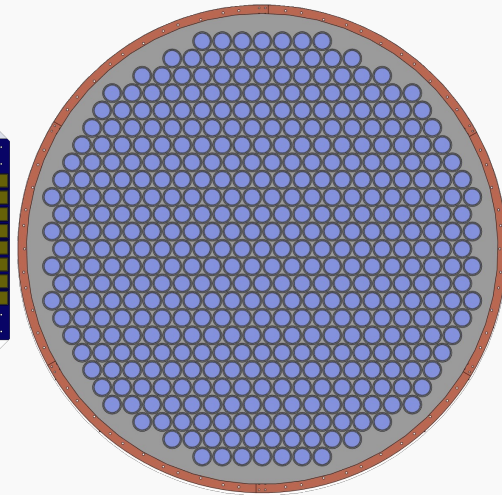
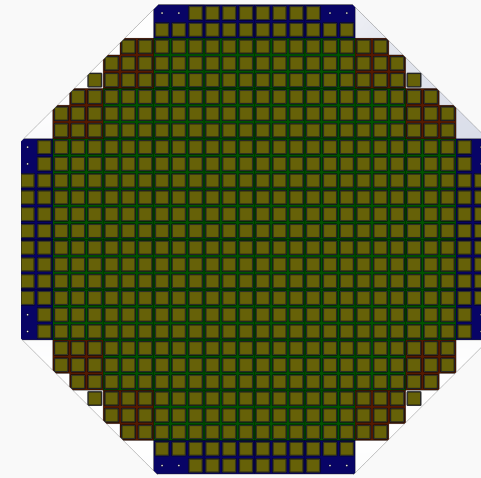



Summary

- Multi-physics goals in PandaX with an active **neutrino program**
- **Solar pp neutrino** measured with PandaX-4T electron scattering data
- **PandaX-xT** with competitive $0\nu\beta\beta$ and solar neutrino detection capabilities
- Next stage: 20T detector is planned to get online in 2027; **physics data in 2028**

PandaX PRELIMINARY

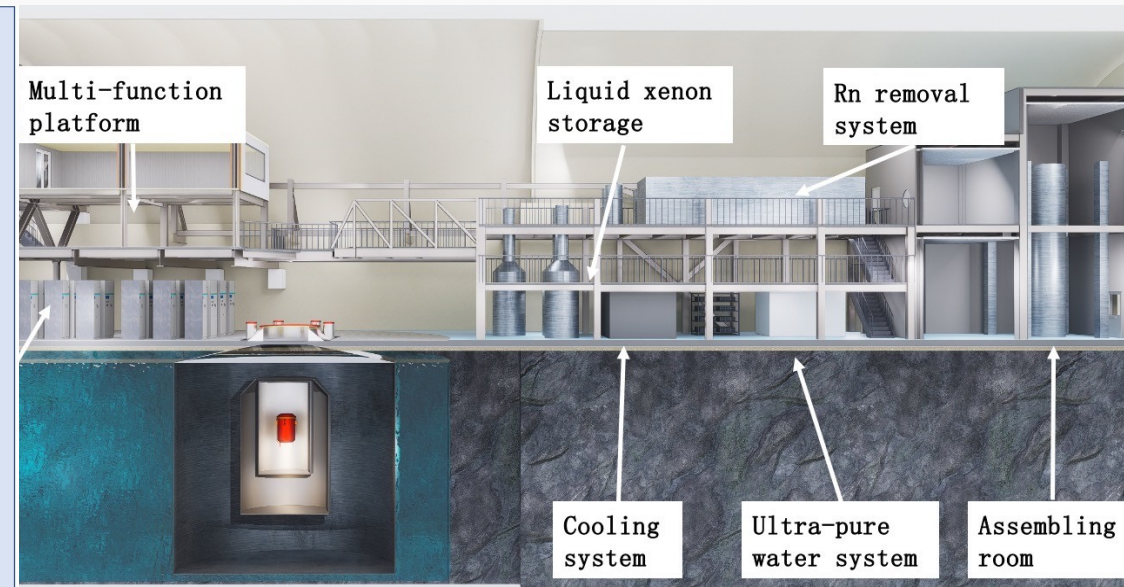
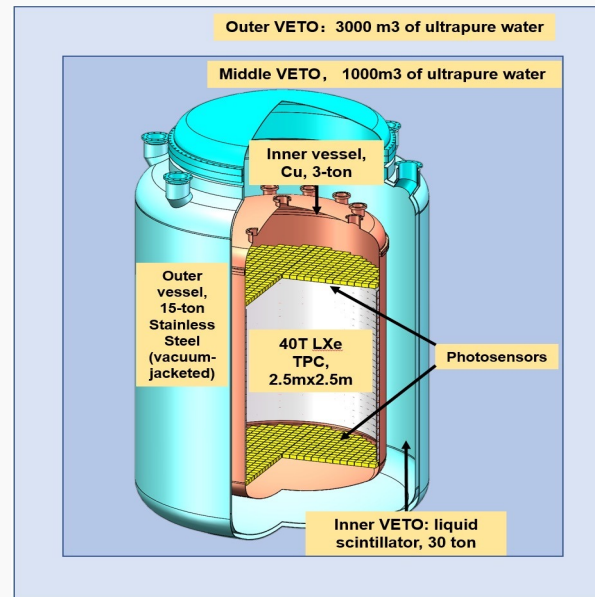
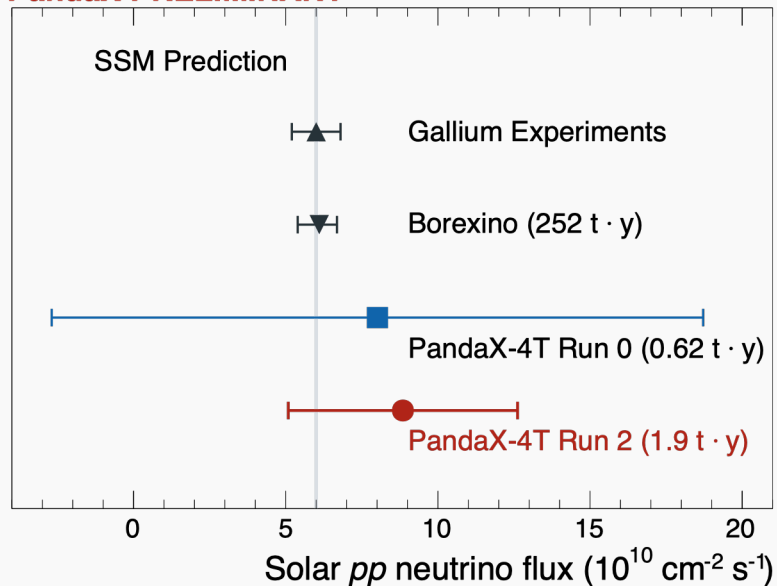





$^{134}\text{Xe } 2\nu\beta\beta \text{ and } 0\nu\beta\beta$

- $Q=826 \text{ keV}$; Half-life from theoretical predictions: $10^{24} - 10^{25} \text{ yr}$; Never been observed
- Discovery within reach with a natural Xe TPC

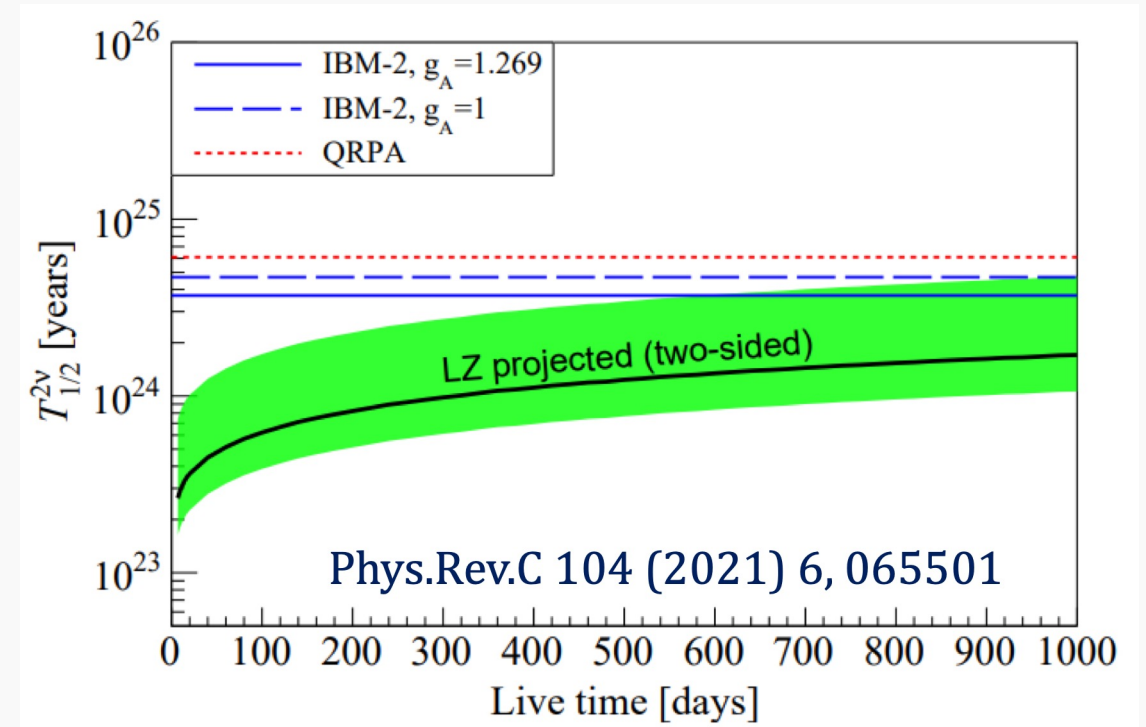
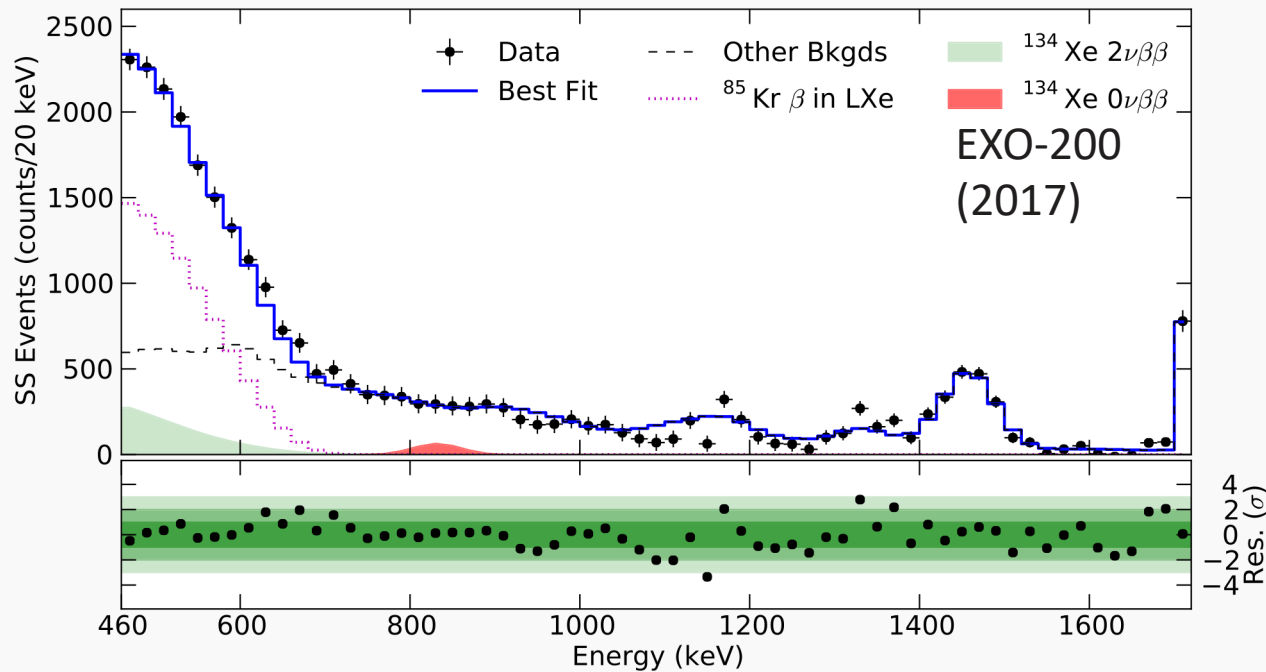



Possible isotope separation/enrichment

- Xenon with artificially modified isotopic abundance (AMIA) for smoking gun discovery
 - A split of odd and even nuclei
 - Further enrichment of ^{136}Xe
 - to improve sensitivity to spin-dependence of DM-nucleon interactions and $0\nu\beta\beta$

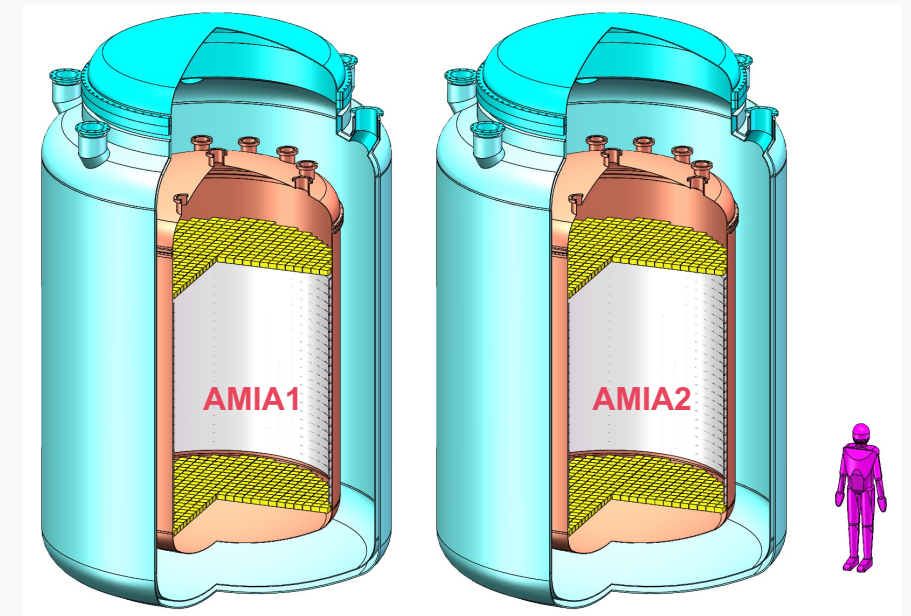
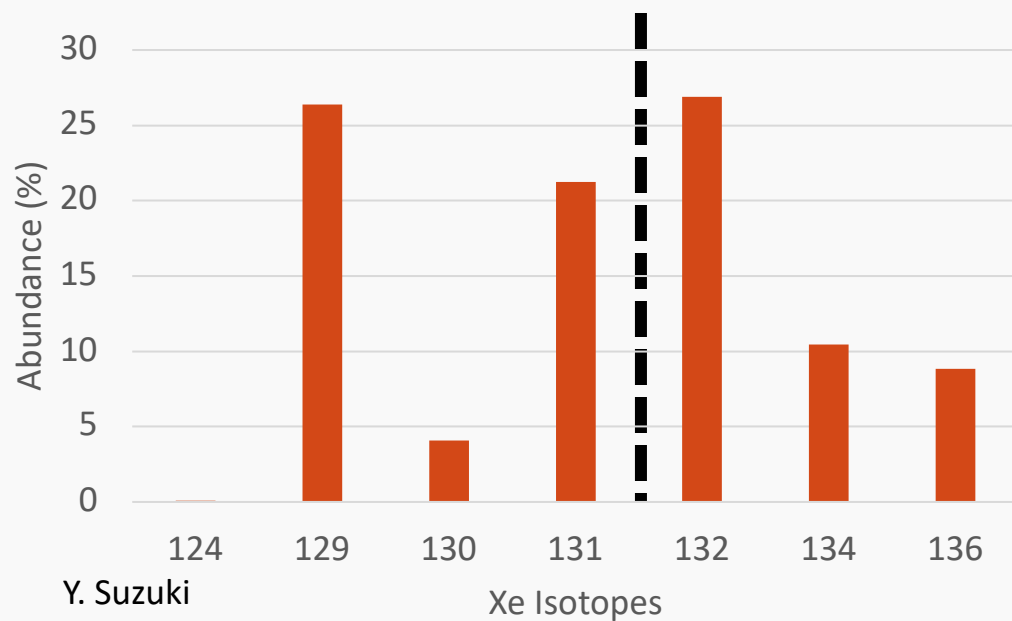



$0\nu\beta\beta + 0\nu\beta\beta-ES$

- Future $0\nu\beta\beta$ projects:
 - Modular solid-state detectors (LEGEND, CUPID, etc)
 - Liquid scintillator detectors (K2Z, JUNO)
 - Xenon TPC (PandaX, XLZD)
- Xenon TPC is the most effective technology to detect $0\nu\beta\beta-ES$
 - tag beta + gamma
 - Less background-prone
- A combined analysis of $0\nu\beta\beta + 0\nu\beta\beta-ES$ helps improve the sensitivity to $m_{\beta\beta}$.
 - Chenrong Ding, KH, Shaobo Wang, Jiangming Yao

