

Project 8 and Other Emerging Direct Neutrino Mass Experiments

XXXII International Conference on Neutrino Physics and Astrophysics
University of California, Irvine

Pranava Teja Surukuchi
(On behalf of the Project 8 Collaboration)
June 23, 2026

PROJECT 8



University of
Pittsburgh

Evolution of Direct Neutrino Mass Limits

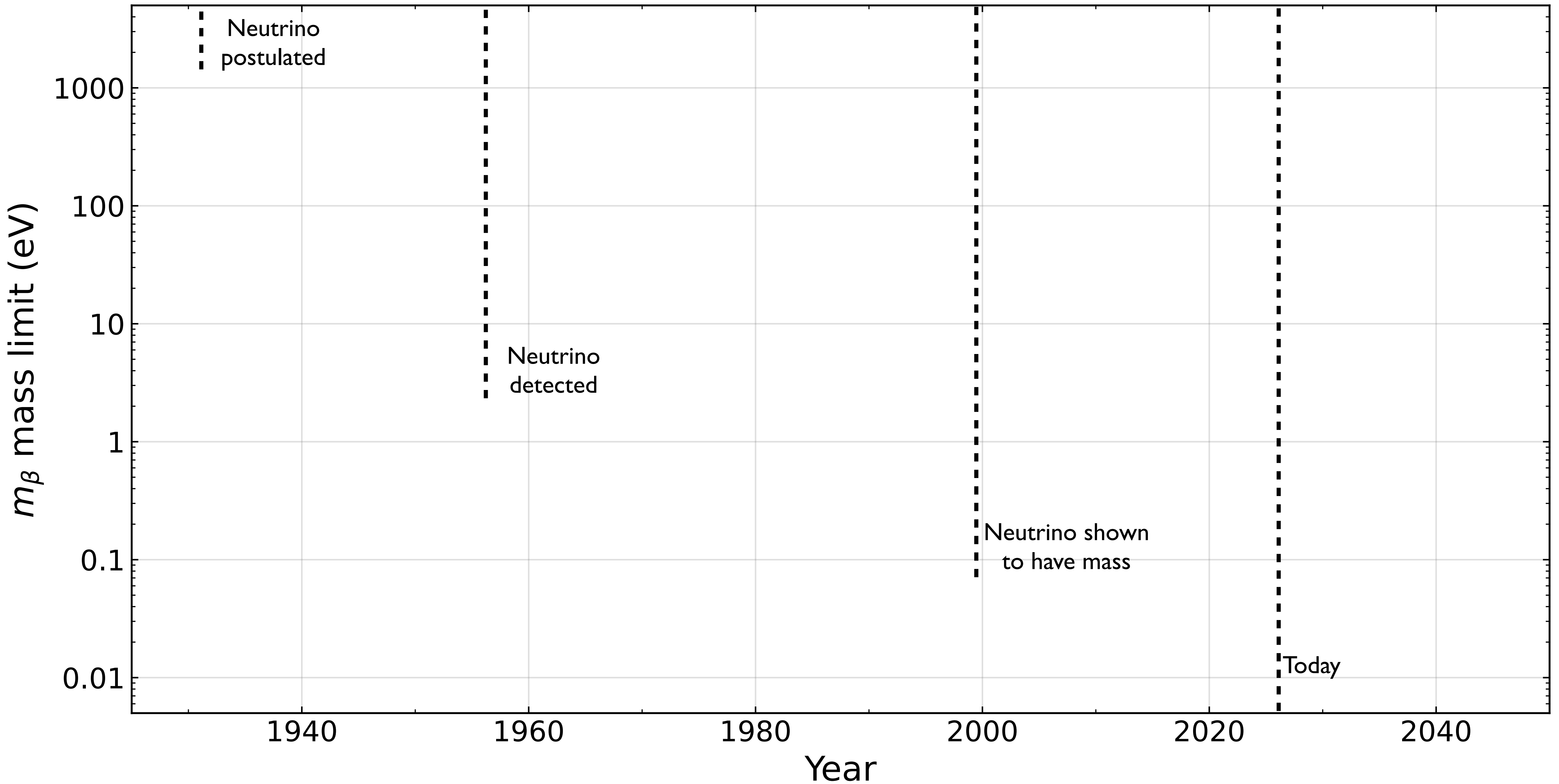

Evolution of Direct Neutrino Mass Limits

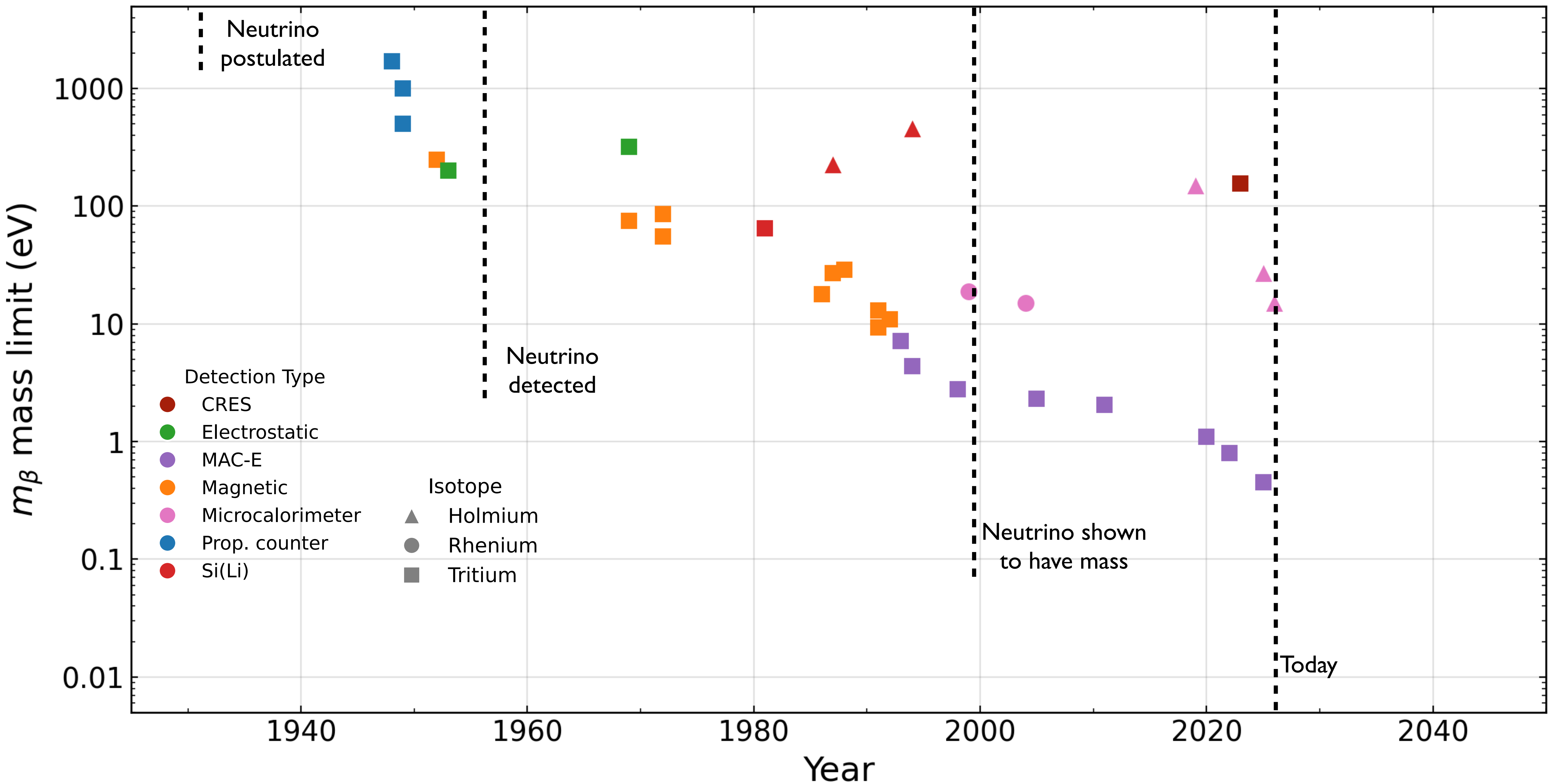

Evolution of Direct Neutrino Mass Limits

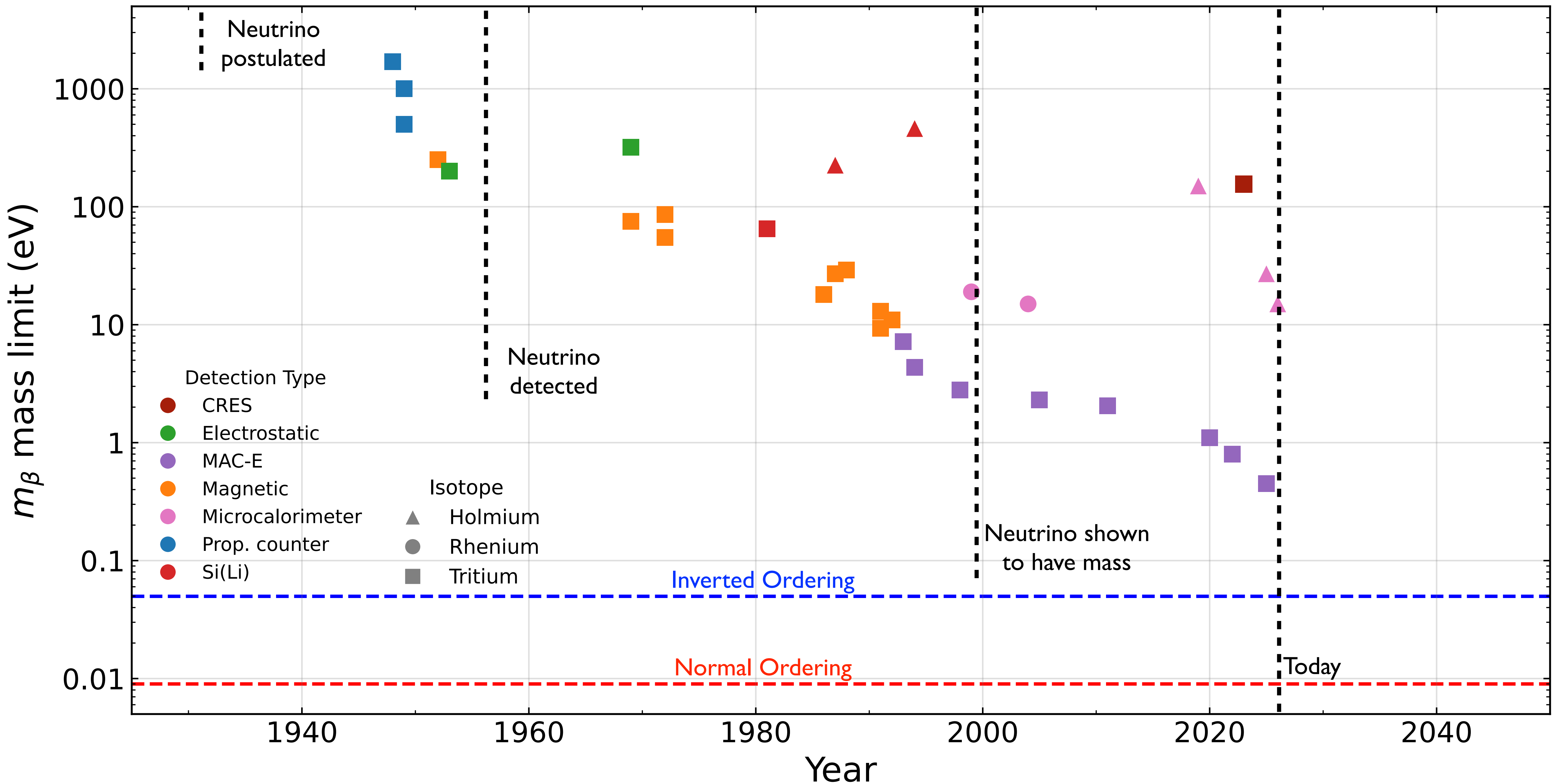

Evolution of Direct Neutrino Mass Limits

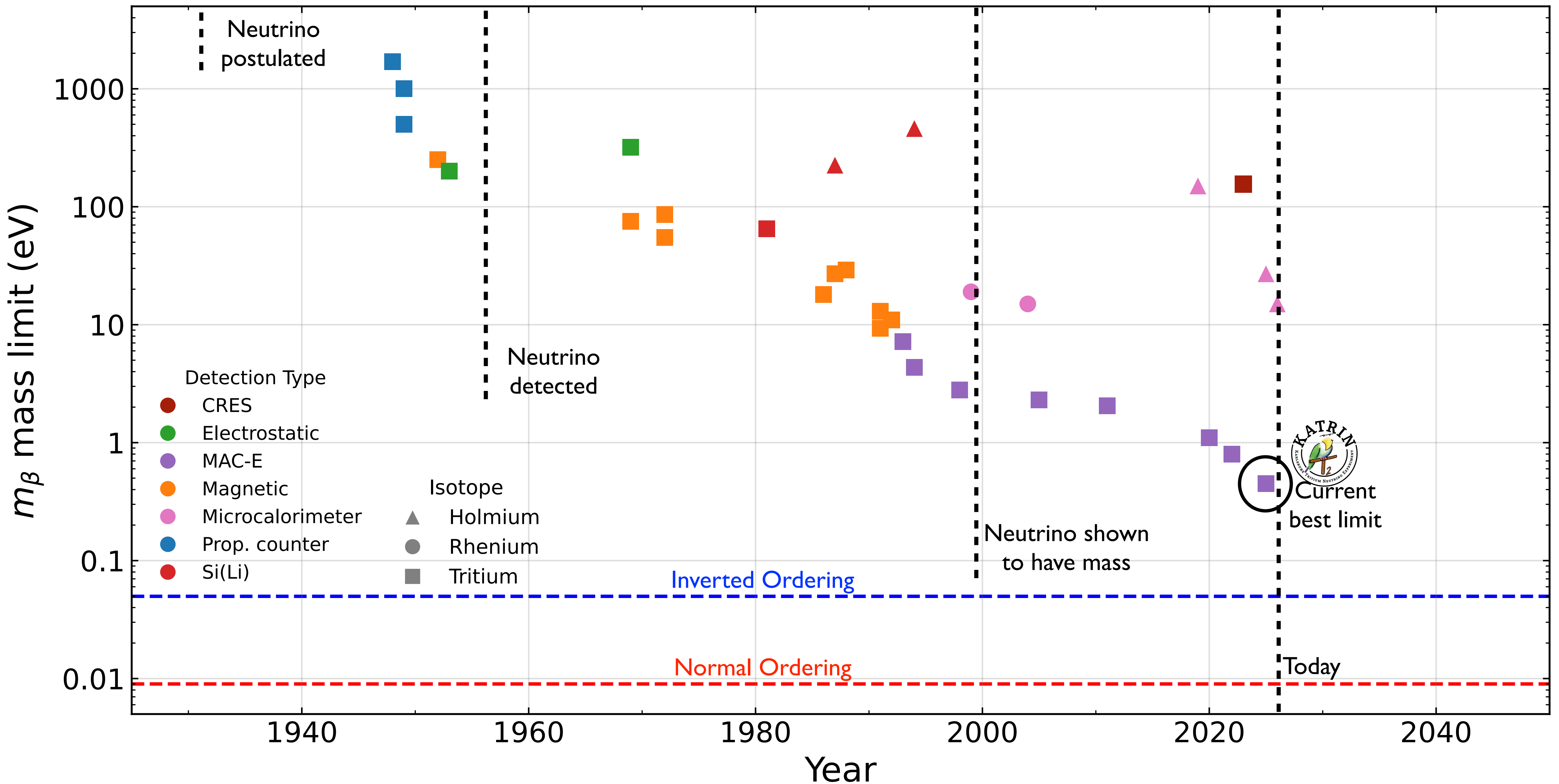

Evolution of Direct Neutrino Mass Limits

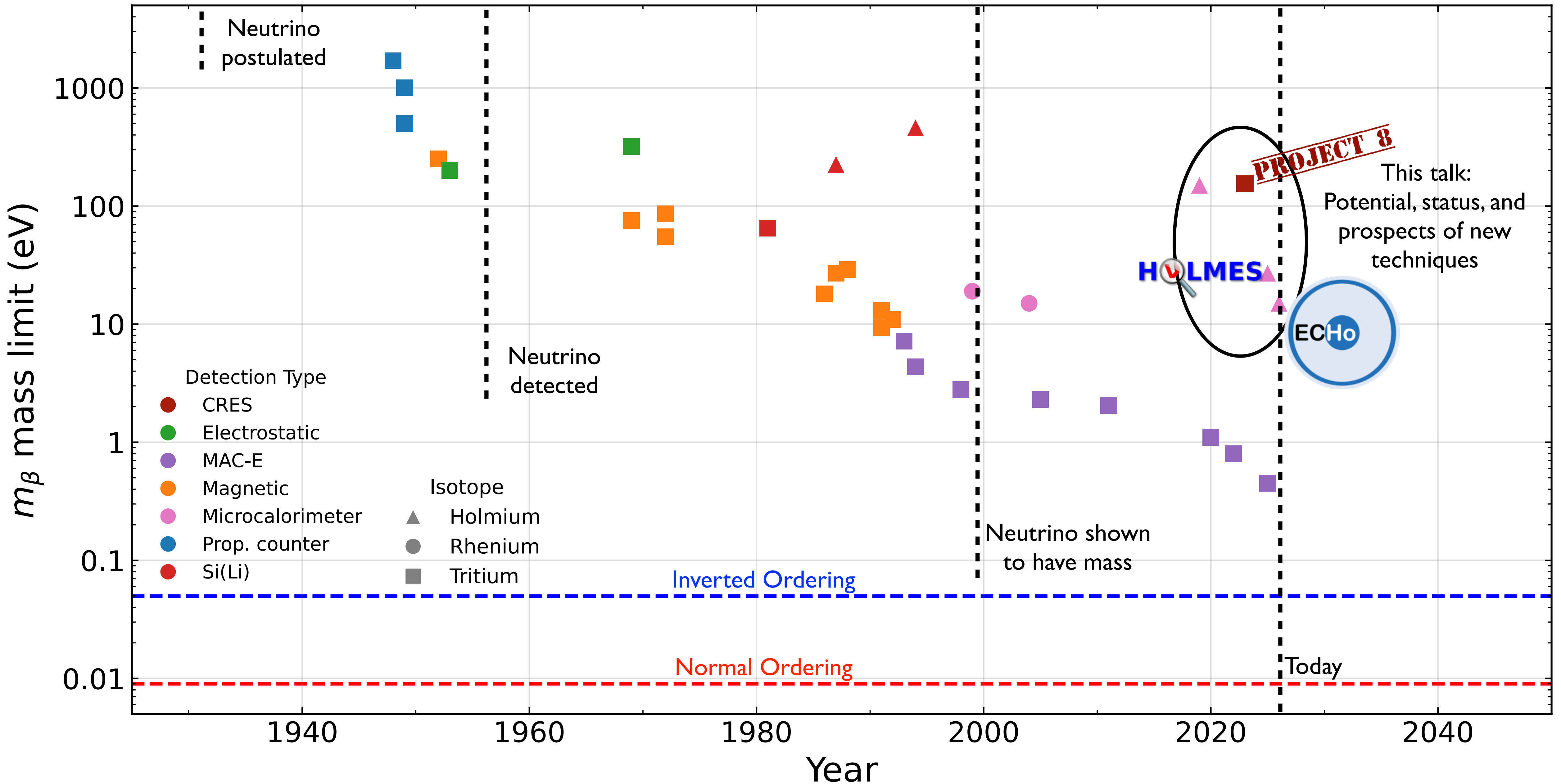



Neutrino Mass Measurement with Endpoint Method

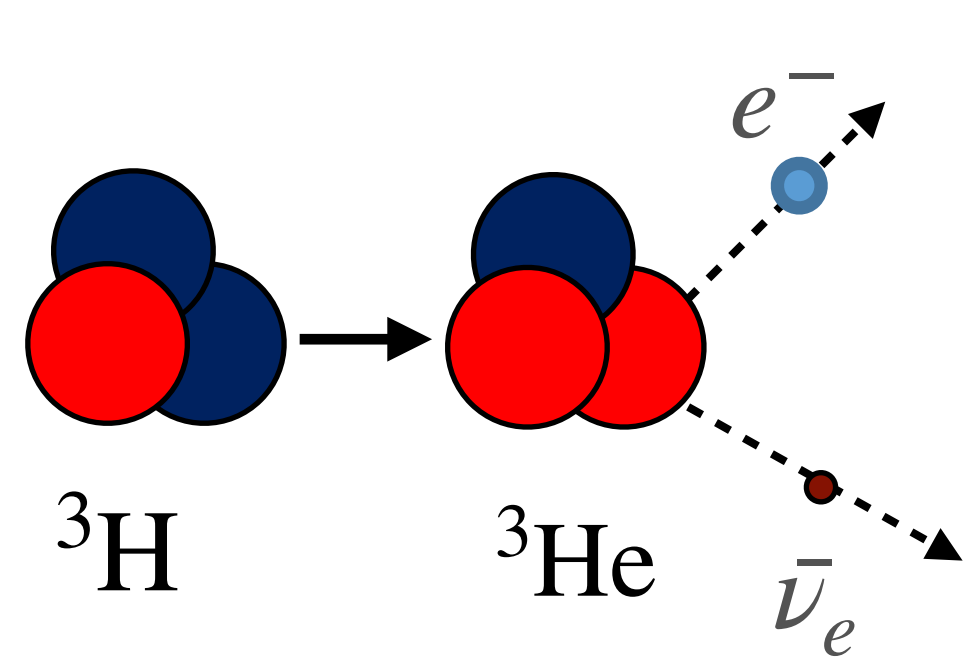

- Beta decay of neutron-rich nucleus
- Anti-neutrino escapes; electron's kinetic energy encodes neutrino mass
- Tritium:
 - $\tau_{1/2} = 12.3 \text{ yr}$
 - Fraction in last eV: 2.9×10^{-13}
 - Well-understood final state distribution

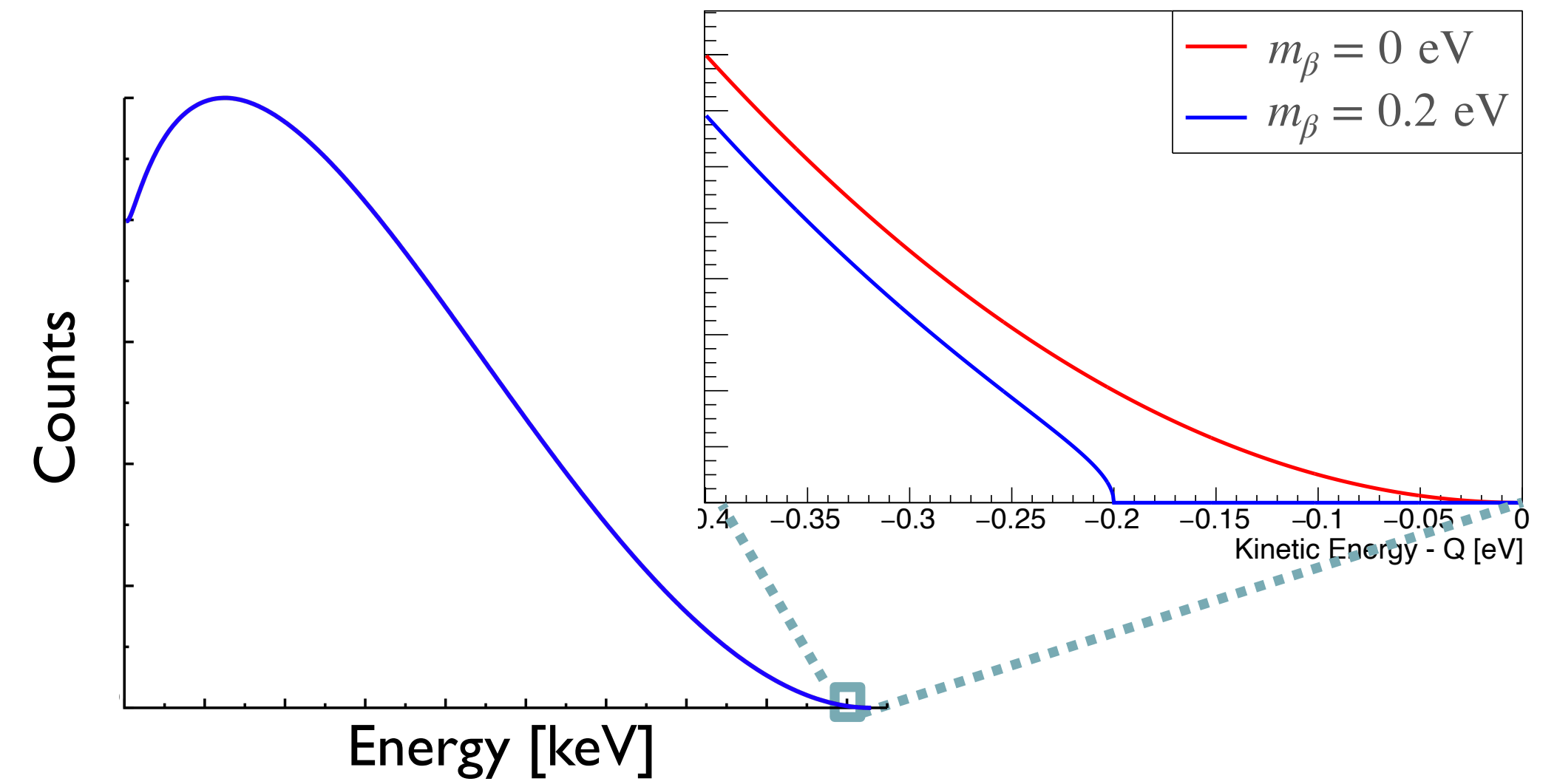



Neutrino Mass Measurement with Endpoint Method

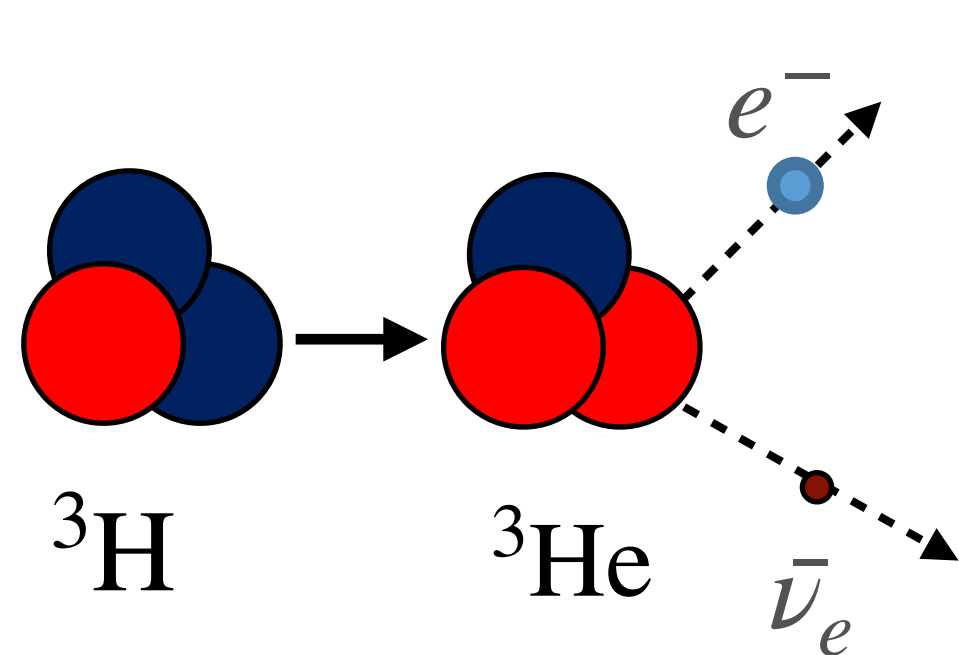

- Beta decay of neutron-rich nucleus
- Anti-neutrino escapes; electron's kinetic energy encodes neutrino mass
- Tritium:
 - $\tau_{1/2} = 12.3 \text{ yr}$
 - Fraction in last eV: 2.9×10^{-13}
 - Well-understood final state distribution

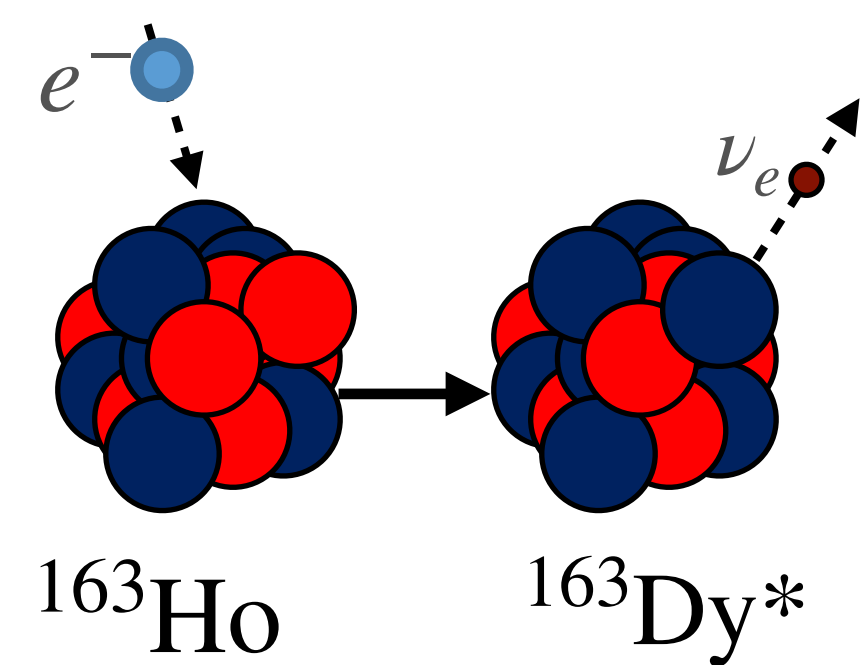
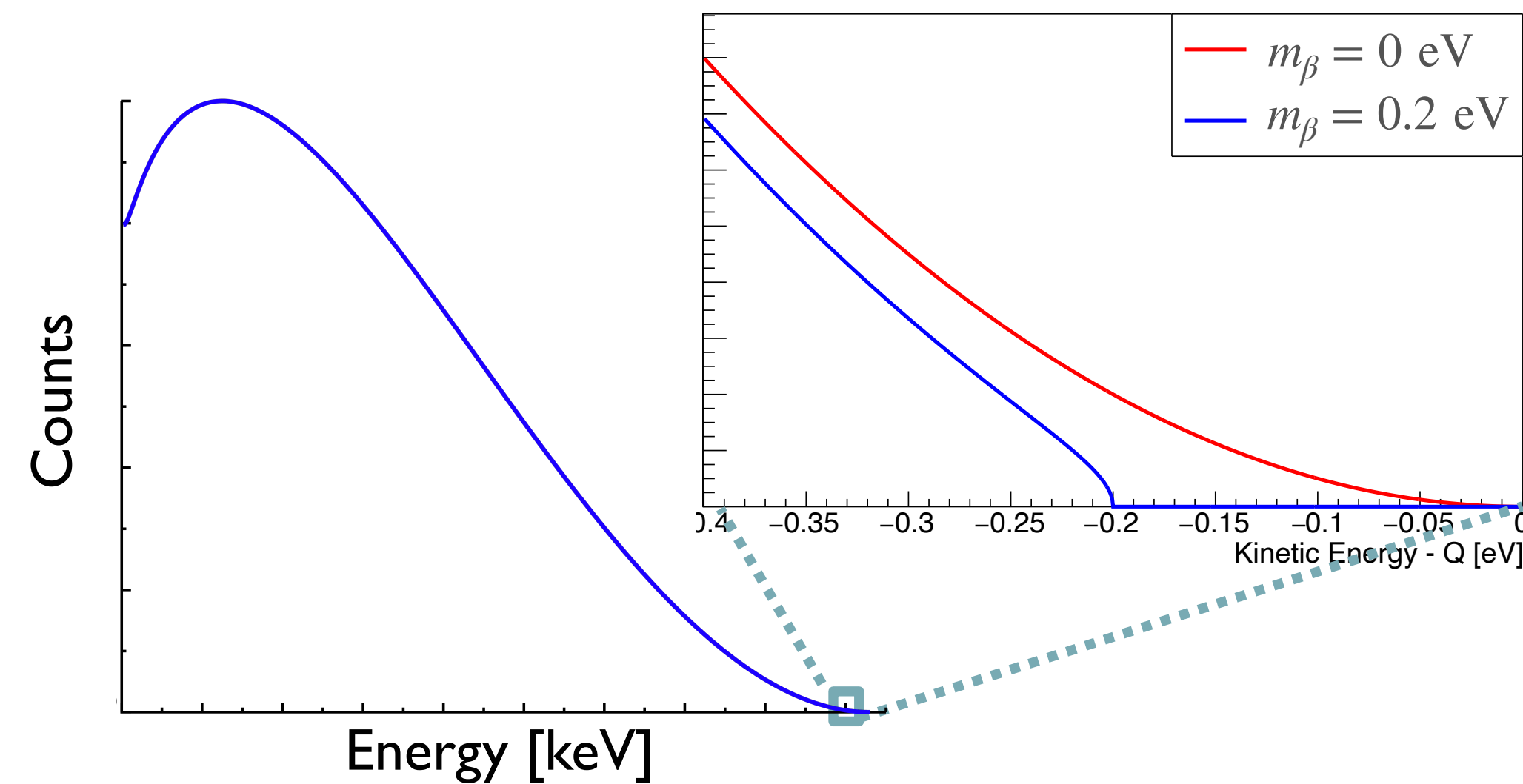

- Atomic electron capture by a proton-rich nucleus
- Neutrino escapes; de-excitation energy of the daughter nucleus encodes neutrino mass
- ${}^{163}\text{Ho}$:
 - $\tau_{1/2} = 4570 \text{ yr}$
 - Fraction in last eV: $\sim 10^{-12}$
 - Precise modeling required; significant recent progress

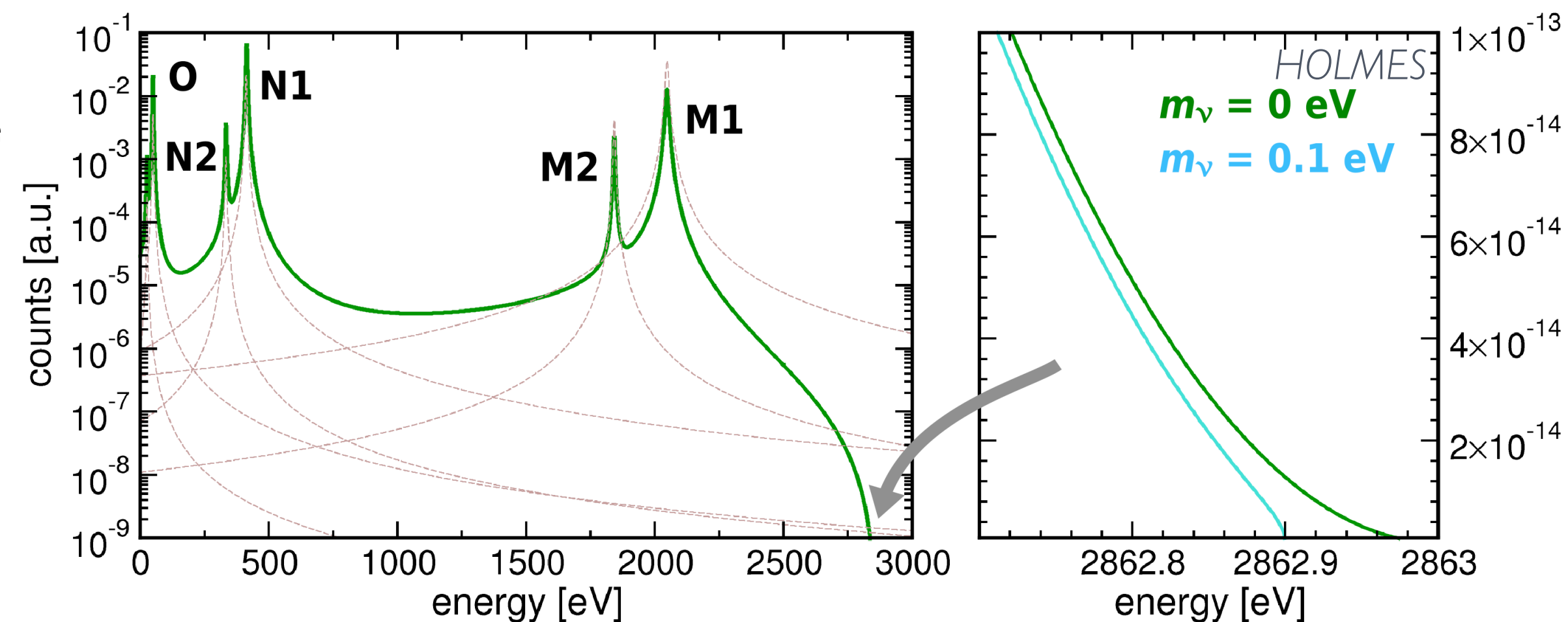
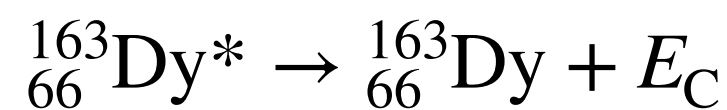



Neutrino Mass Measurement with Endpoint Method

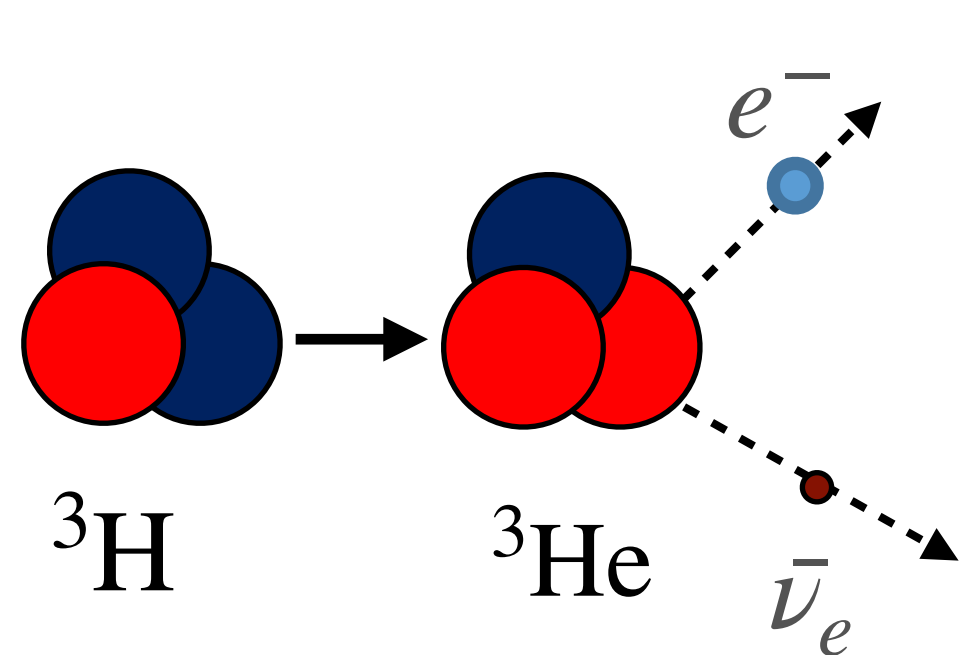

- Beta decay of neutron-rich nucleus
- Anti-neutrino escapes; electron's kinetic energy encodes neutrino mass
- Tritium:
 - $\tau_{1/2} = 12.3 \text{ yr}$
 - Fraction in last eV: 2.9×10^{-13}
 - Well-understood final state distribution

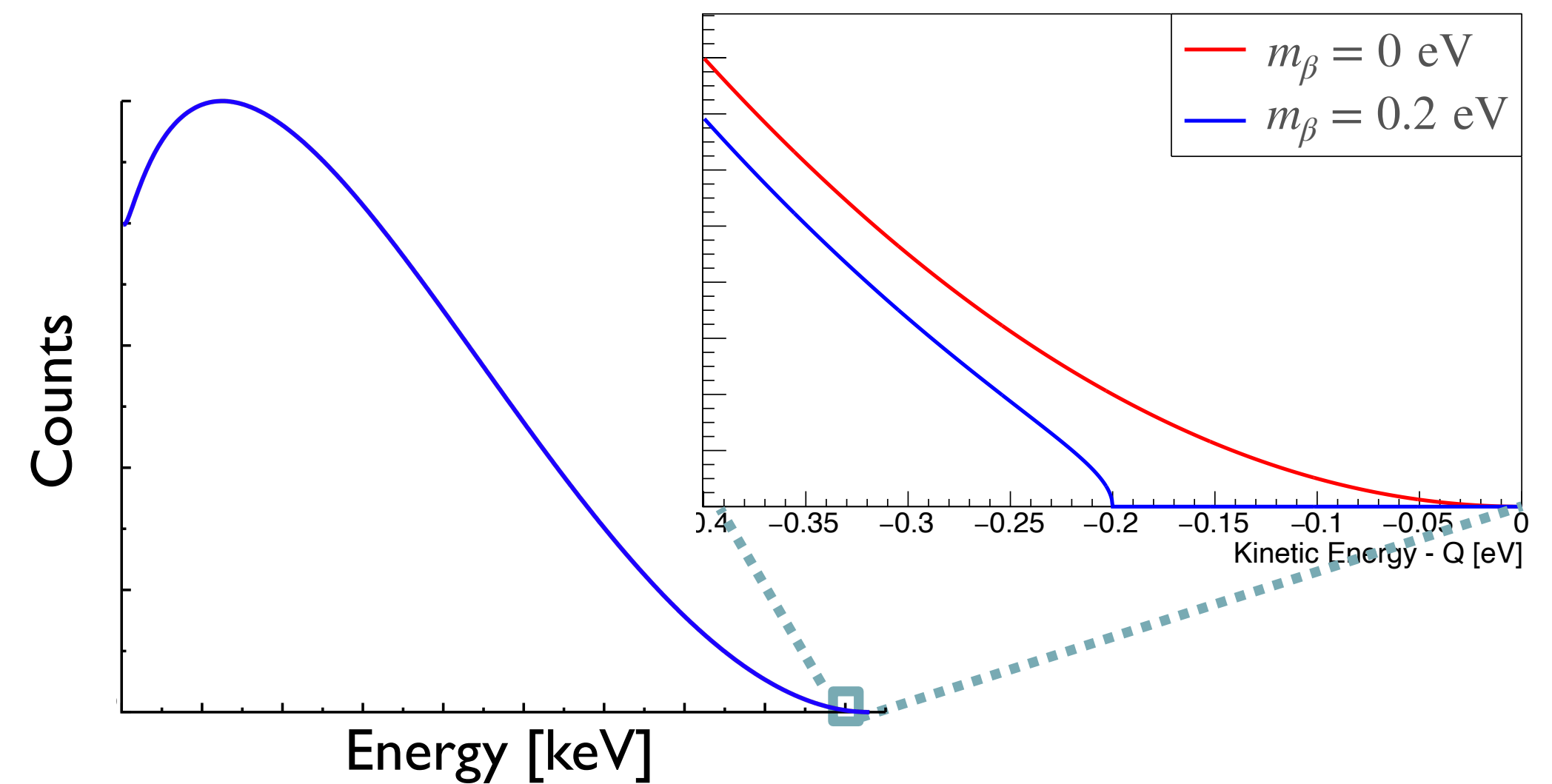

$$m_\beta^2 = \sum_{i=1,2,3} |U_{ei}|^2 m_i^2$$

β decay and EC use the same endpoint physics to directly probe the neutrino mass

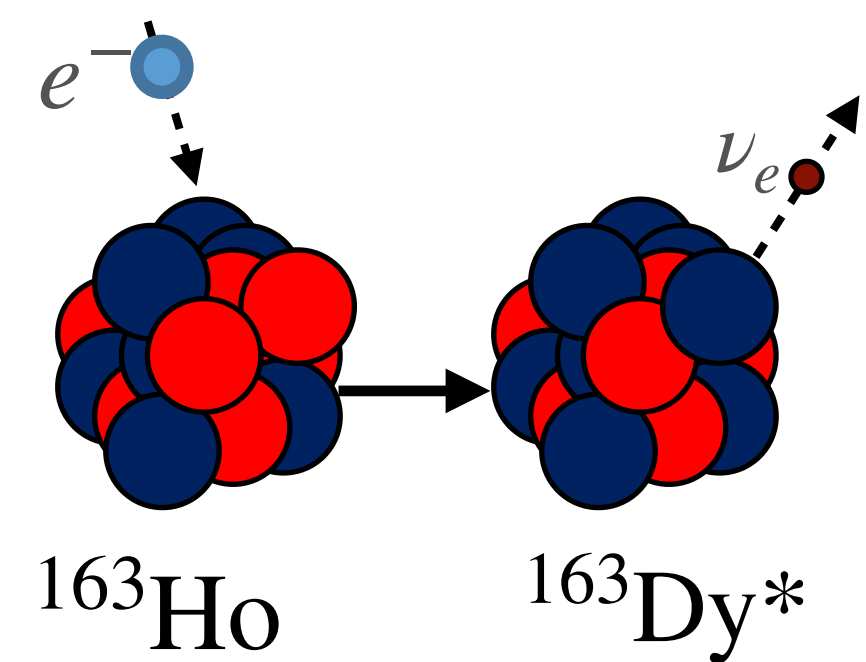

- Atomic electron capture by a proton-rich nucleus
- Neutrino escapes; de-excitation energy of the daughter nucleus encodes neutrino mass
- ${}^{163}\text{Ho}$:
 - $\tau_{1/2} = 4570 \text{ yr}$
 - Fraction in last eV: $\sim 10^{-12}$
 - Precise modeling required; significant recent progress

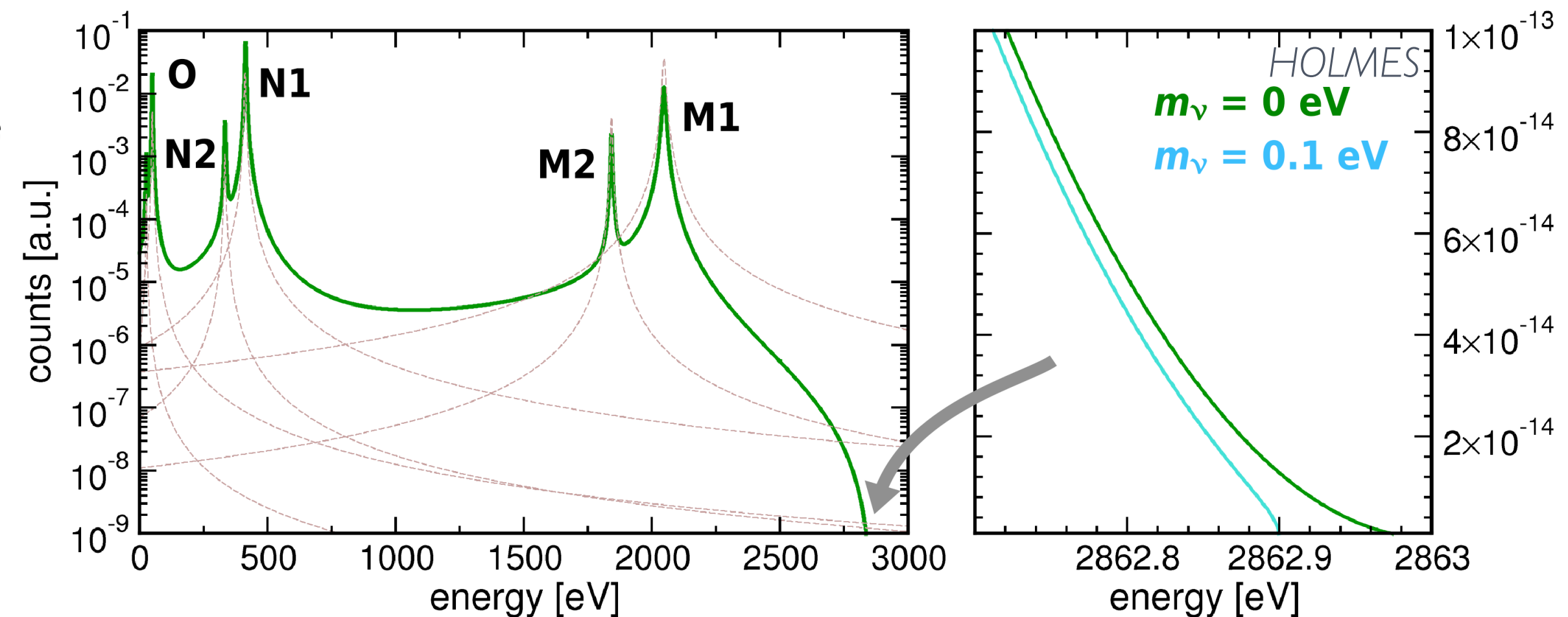
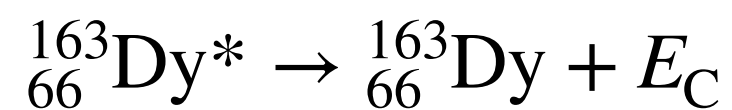



Requirements for a Sensitive Neutrino Mass Experiment

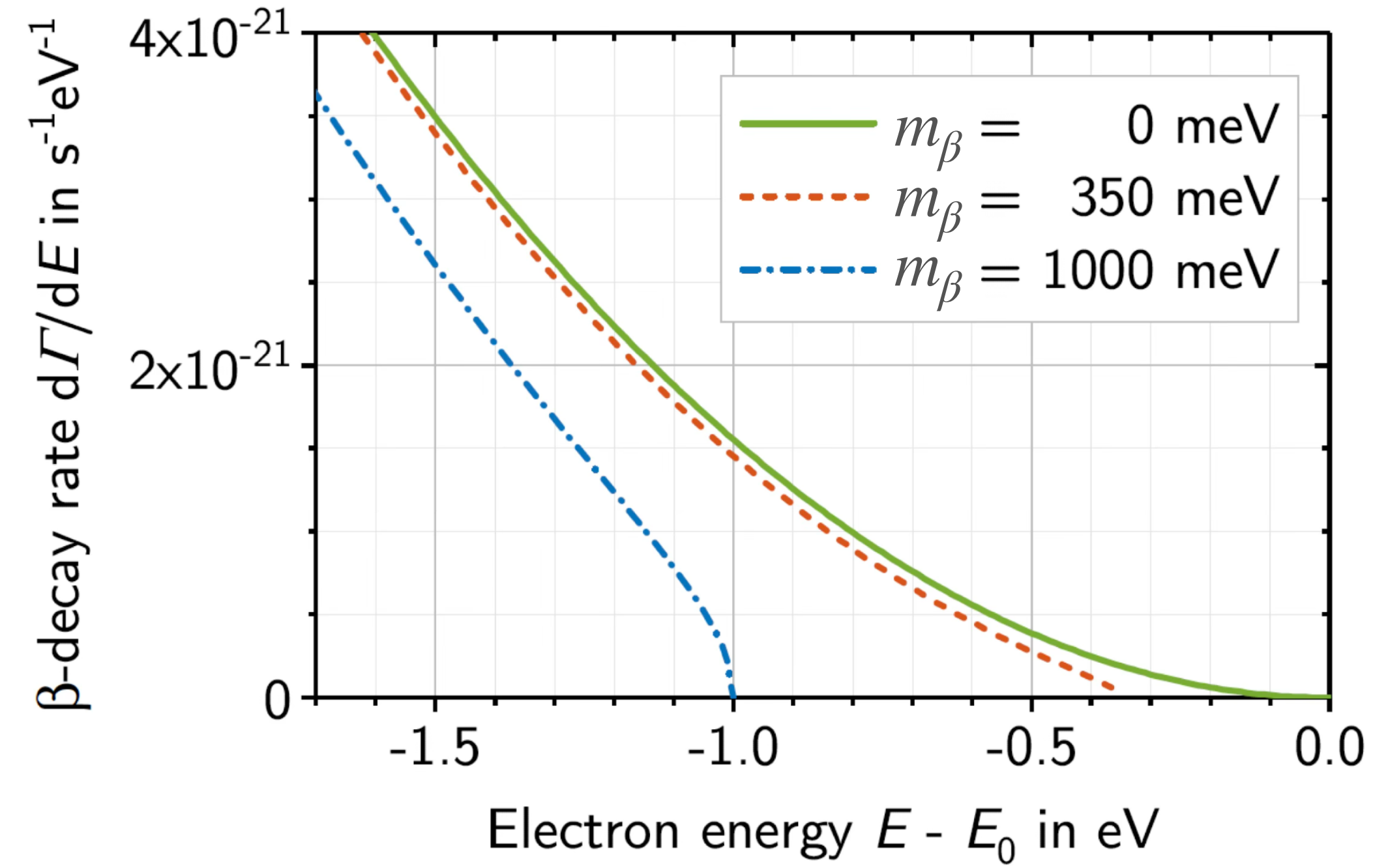

Physics Reports 914, 1-54 (2021)



Requirements for a Sensitive Neutrino Mass Experiment

- The number of events in an optimally chosen analysis window provides the uncertainty on the neutrino mass

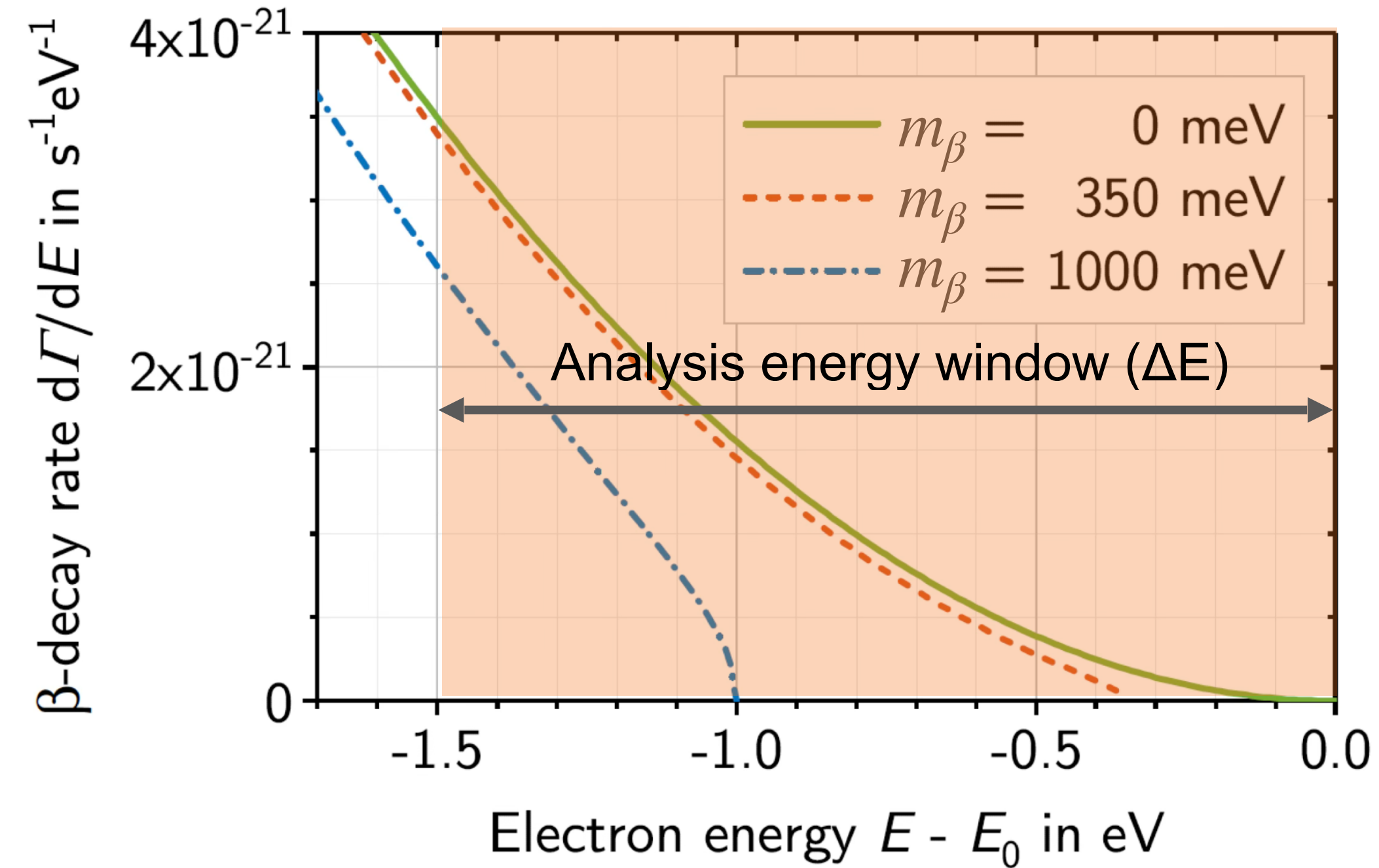

Physics Reports 914, 1-54 (2021)

Neutrino mass square uncertainty

$$\sigma_{m_\beta^2} = \frac{2}{3} \sqrt{\frac{1}{rt} \left[\Delta E + \frac{b}{r \Delta E} \right] + 4 \sum_i \sigma_i^2 \cdot \delta \sigma_i^2}$$

Labels in the diagram:

- rt : Measurement time
- ΔE : Optimized energy window
- b : background rate
- σ_i^2 : Energy broadening contribution i
- $\delta \sigma_i^2$: Uncertainty on energy broadening contribution i

Physics Reports 914, 1-54 (2021)



Requirements for a Sensitive Neutrino Mass Experiment

- The number of events in an optimally chosen analysis window provides the uncertainty on the neutrino mass
- Experimental requirements for β decays and EC:
 - High statistics ($\propto N^{-1/4}$)
 - Low backgrounds
 - Low energy broadening near the endpoint

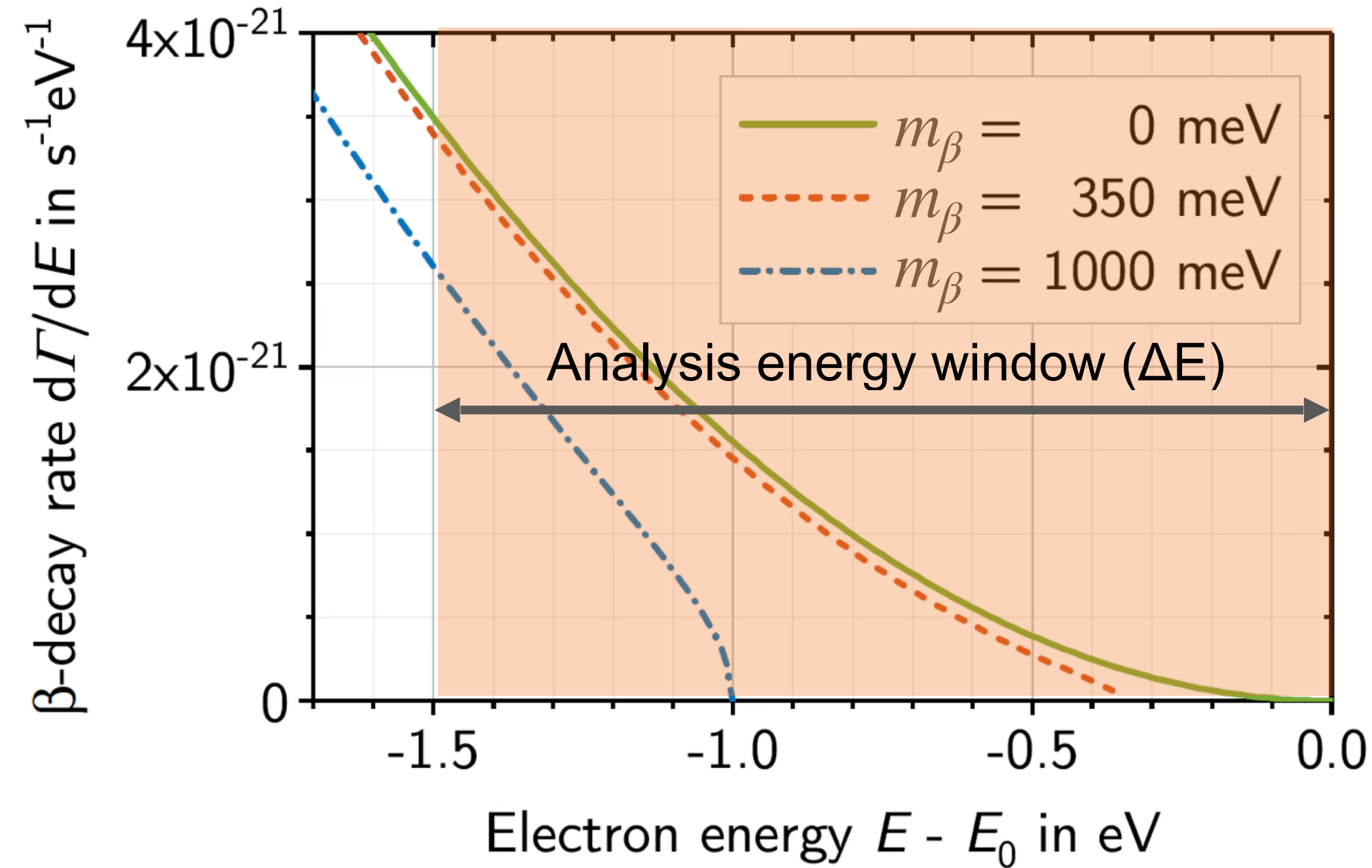

Physics Reports 914, 1-54 (2021)

Neutrino mass square uncertainty $\sigma_{m_\beta^2}$

$$\sigma_{m_\beta^2} = \frac{2}{3} \sqrt{\frac{1}{rt} \left[\Delta E + \frac{b}{r \Delta E} \right] + 4 \sum_i \sigma_i^2 \cdot \delta \sigma_i^2}$$

Labels for the equation components:

- rt : Measurement time
- ΔE : Optimized energy window
- b : background rate
- σ_i^2 : Energy broadening contribution i
- $\delta \sigma_i^2$: Uncertainty on energy broadening contribution i

Physics Reports 914, 1-54 (2021)



Going Beyond the Current State of the Art

- Two very different approaches being actively pursued
- Shared features: source=detector, differential measurement
- Different: detector technologies, isotopes

Cryogenic Microcalorimetry

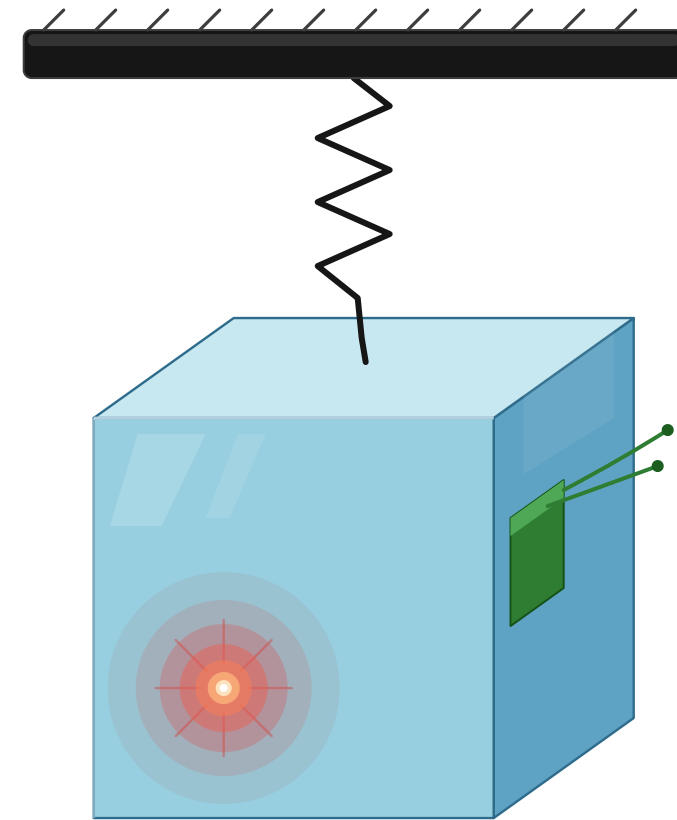

Cyclotron Radiation Emission Spectroscopy (CRES)

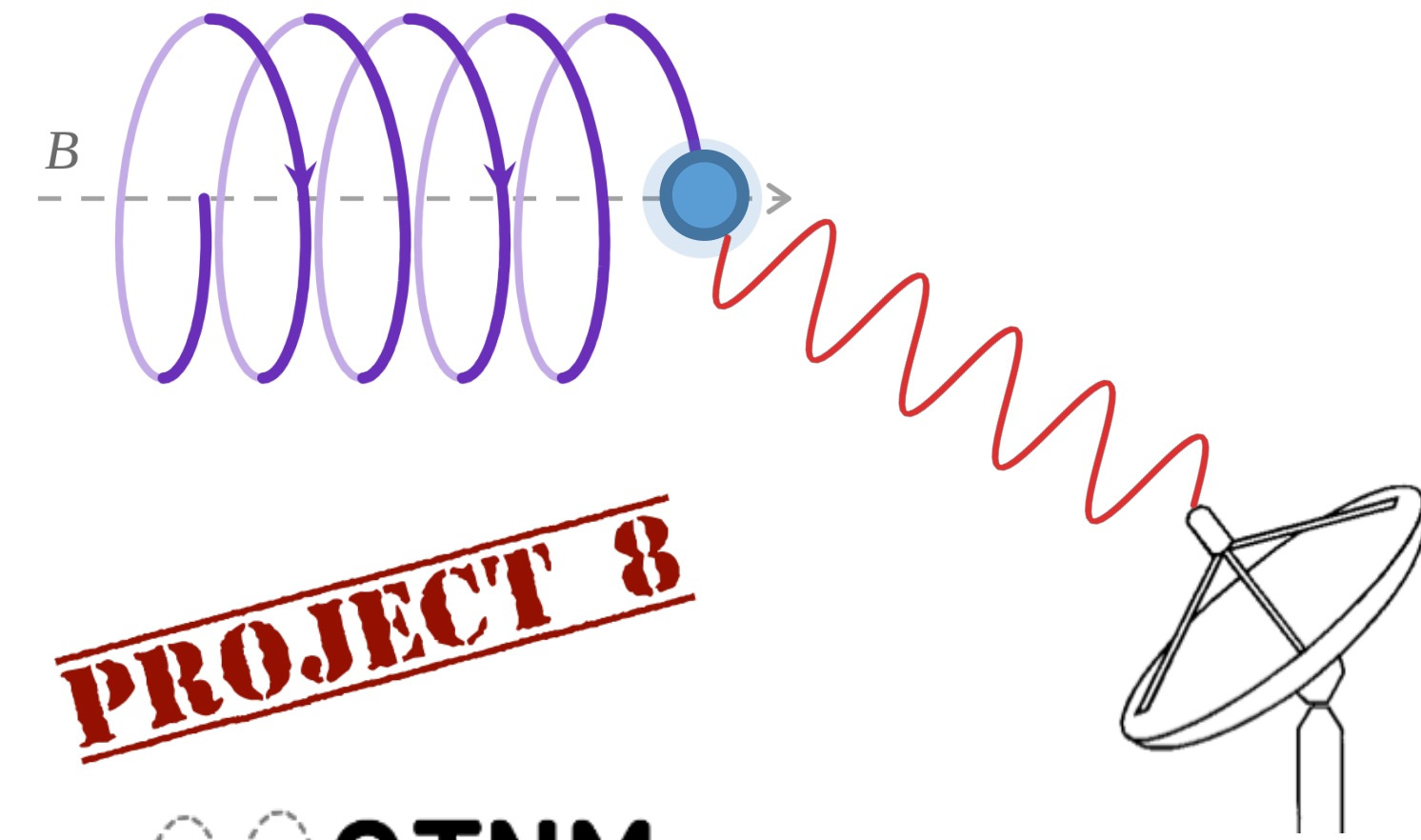

PROJECT 8





Microcalorimetric Approach with ^{163}Ho

- Electron-capture source (^{163}Ho)

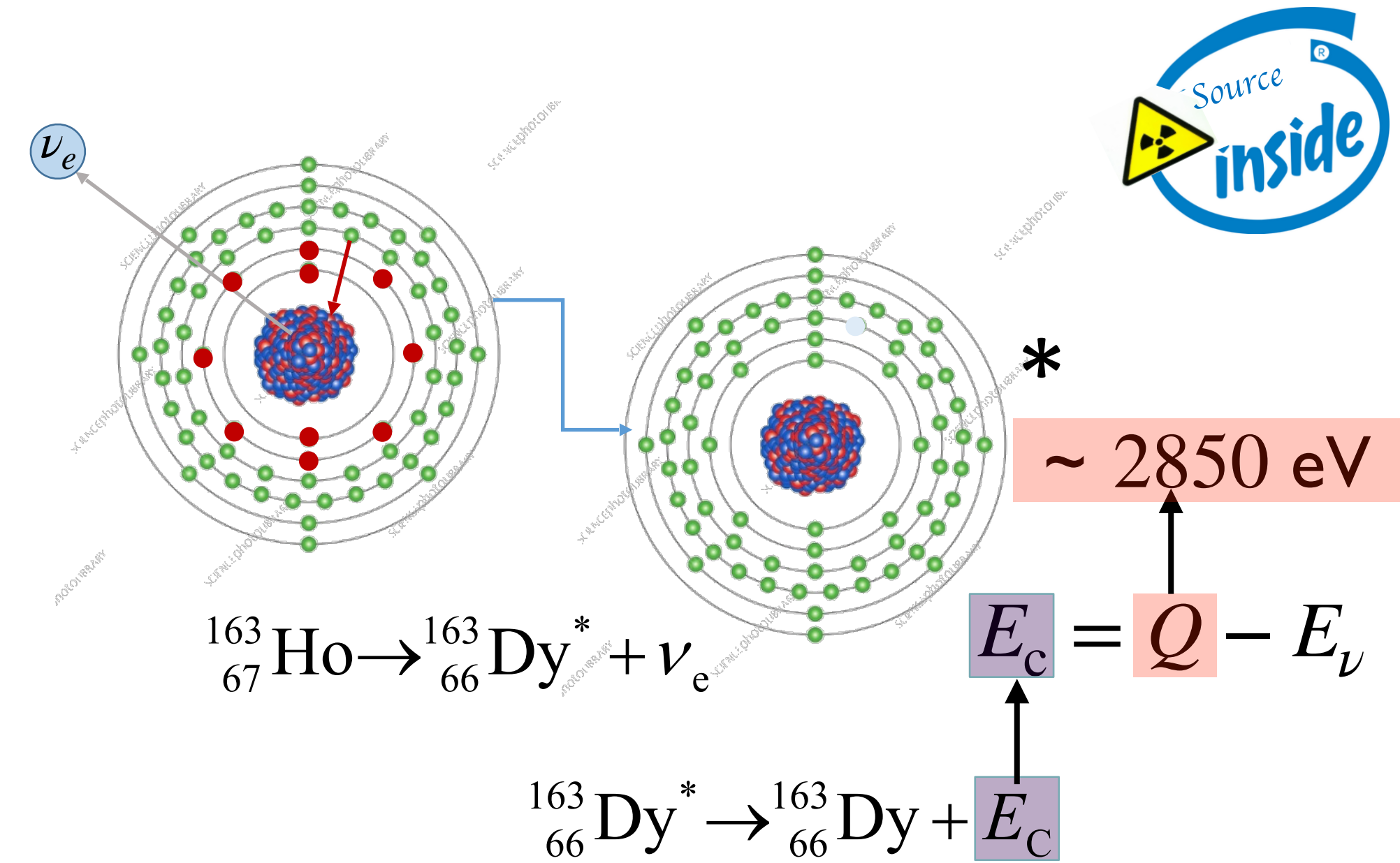



Microcalorimetric Approach with ^{163}Ho

- Electron-capture source (^{163}Ho) embedded in a cryogenic absorber for full containment

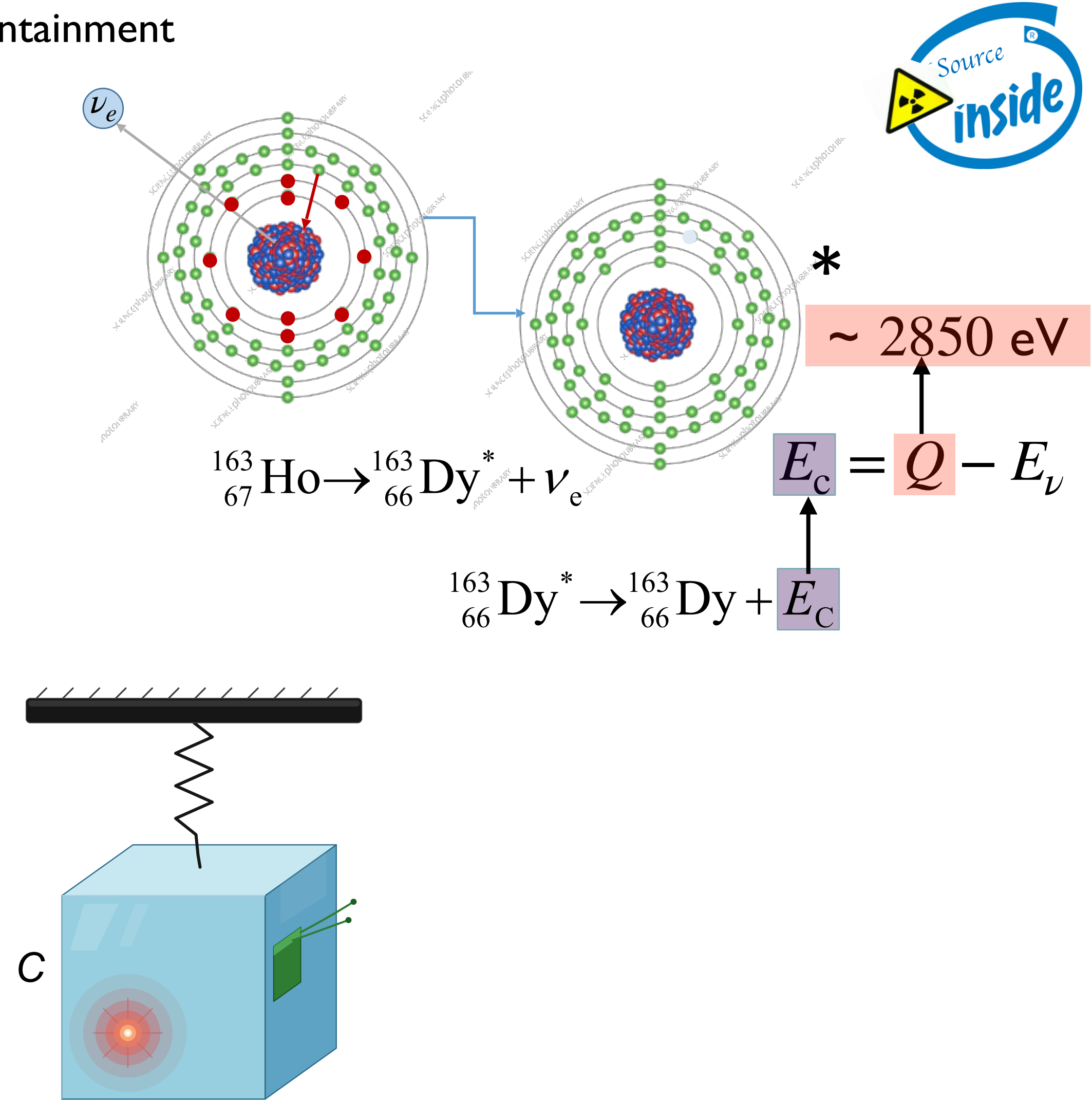



Microcalorimetric Approach with ^{163}Ho

- Electron-capture source (^{163}Ho) embedded in a cryogenic absorber for full containment
- Energy measured as heat at $\sim 100\text{ mK}$: Need microcalorimeters ($100\ \mu\text{m}$)

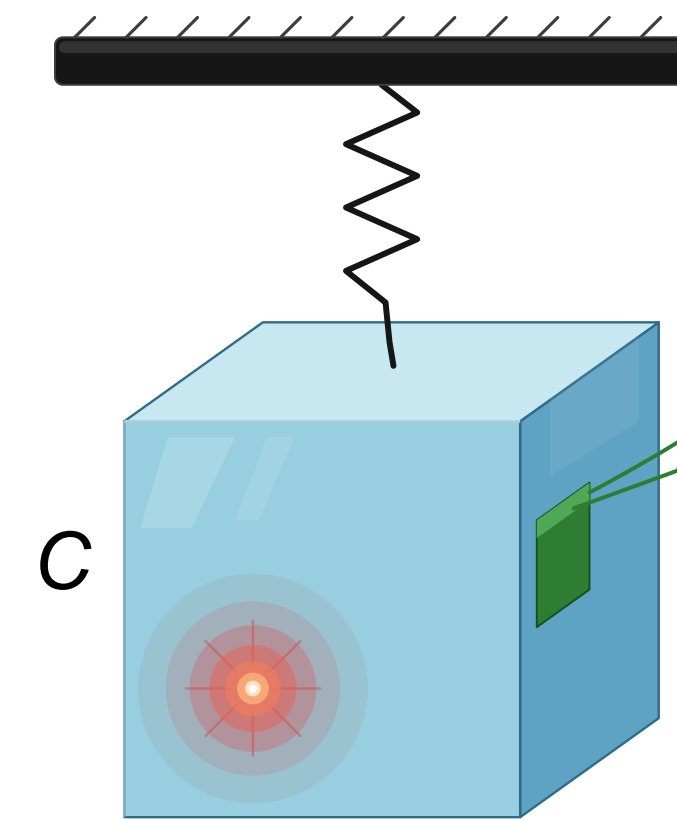
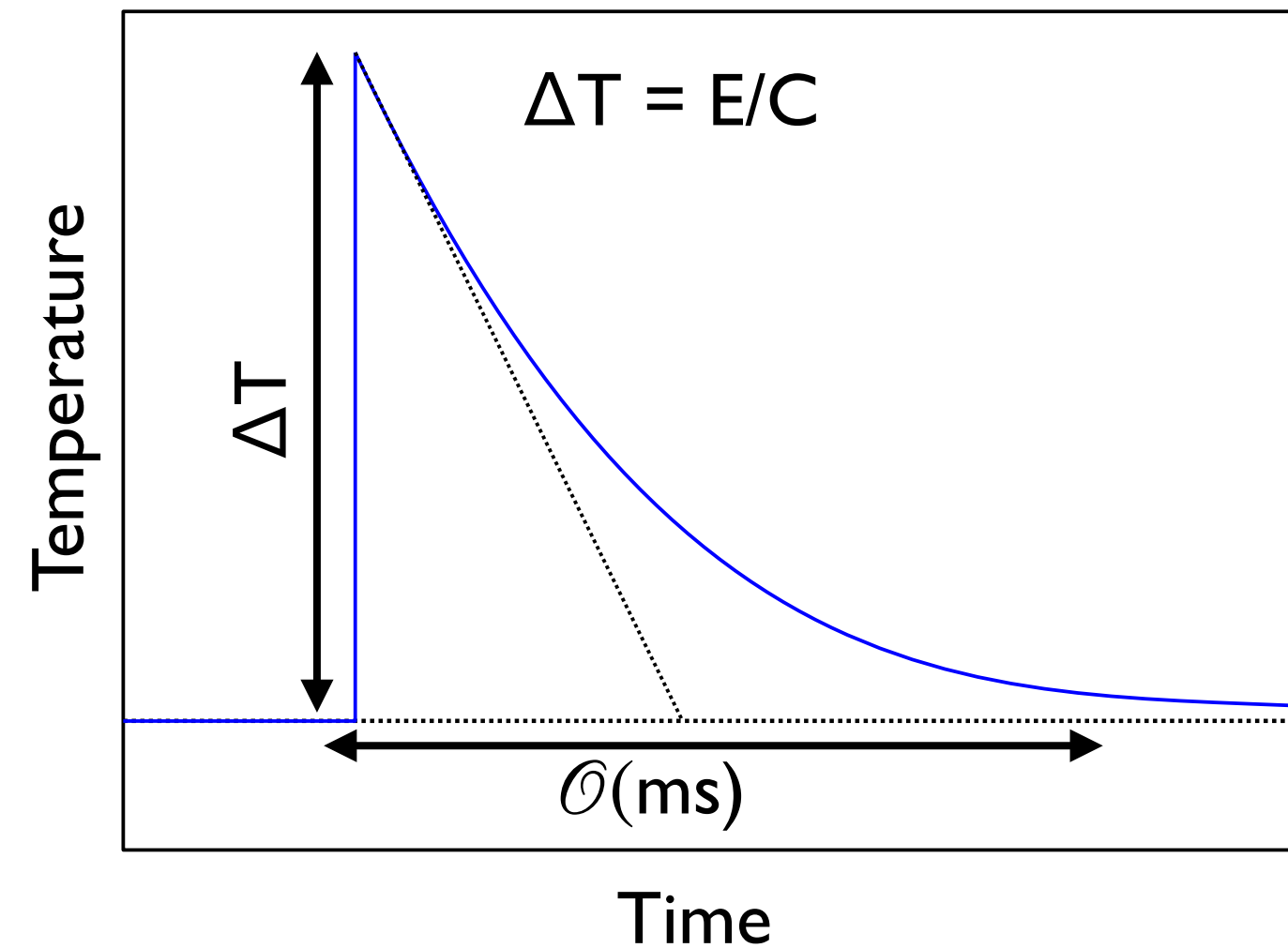
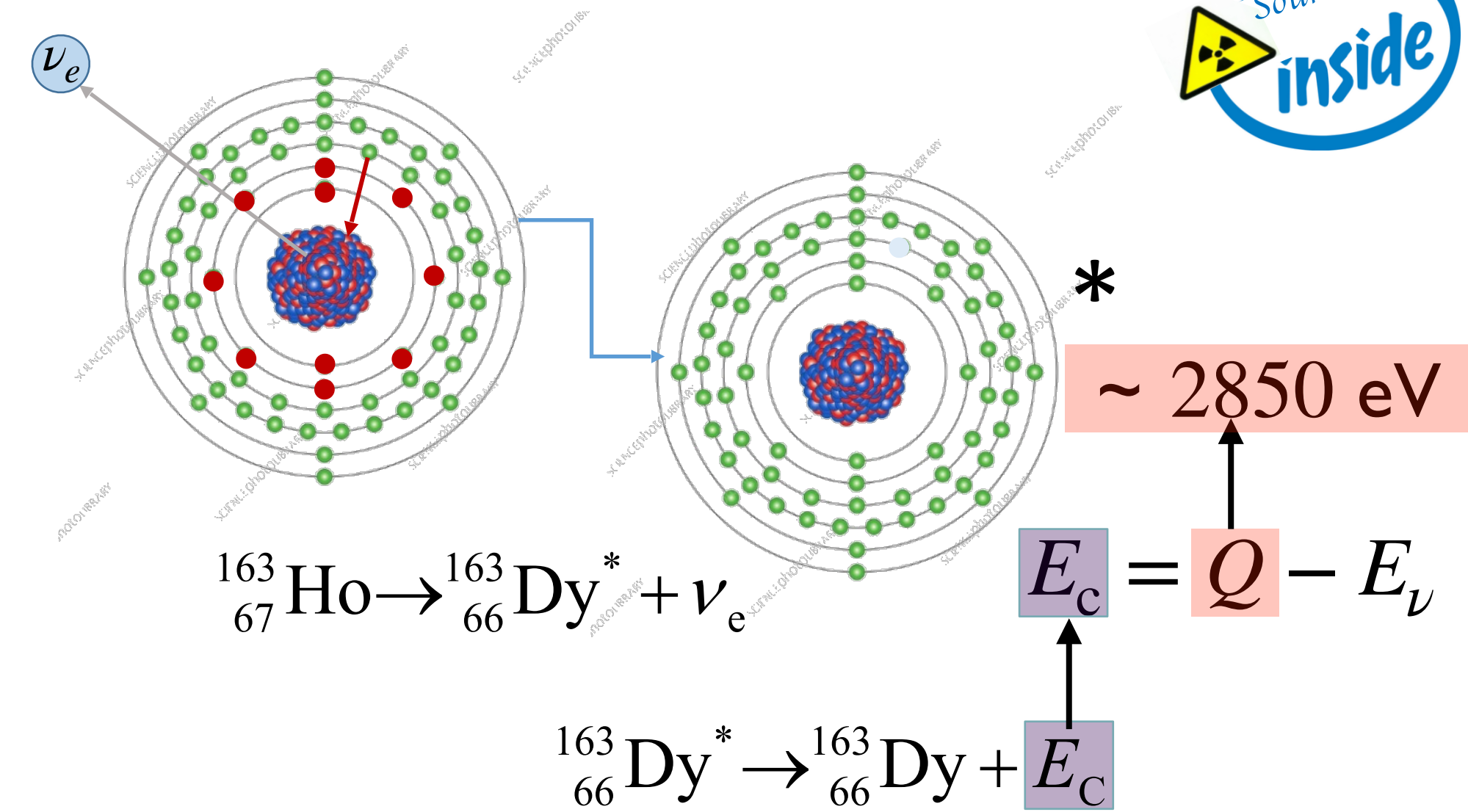



Microcalorimetric Approach with ^{163}Ho

- Electron-capture source (^{163}Ho) embedded in a cryogenic absorber for full containment
- Energy measured as heat at ~ 100 mK: Need microcalorimeters ($100\ \mu\text{m}$)
- Intrinsically differential
- Good energy resolution
- Compact and scalable
- Cryogenic calorimeters are inherently slow
- Pileup is a major concern
- Scaling is done through multiplexed arrays

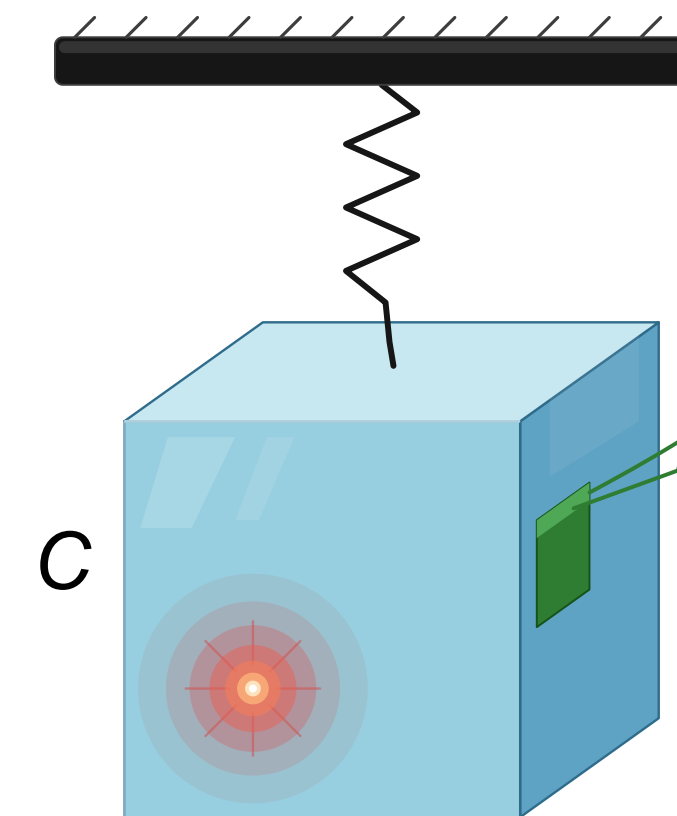
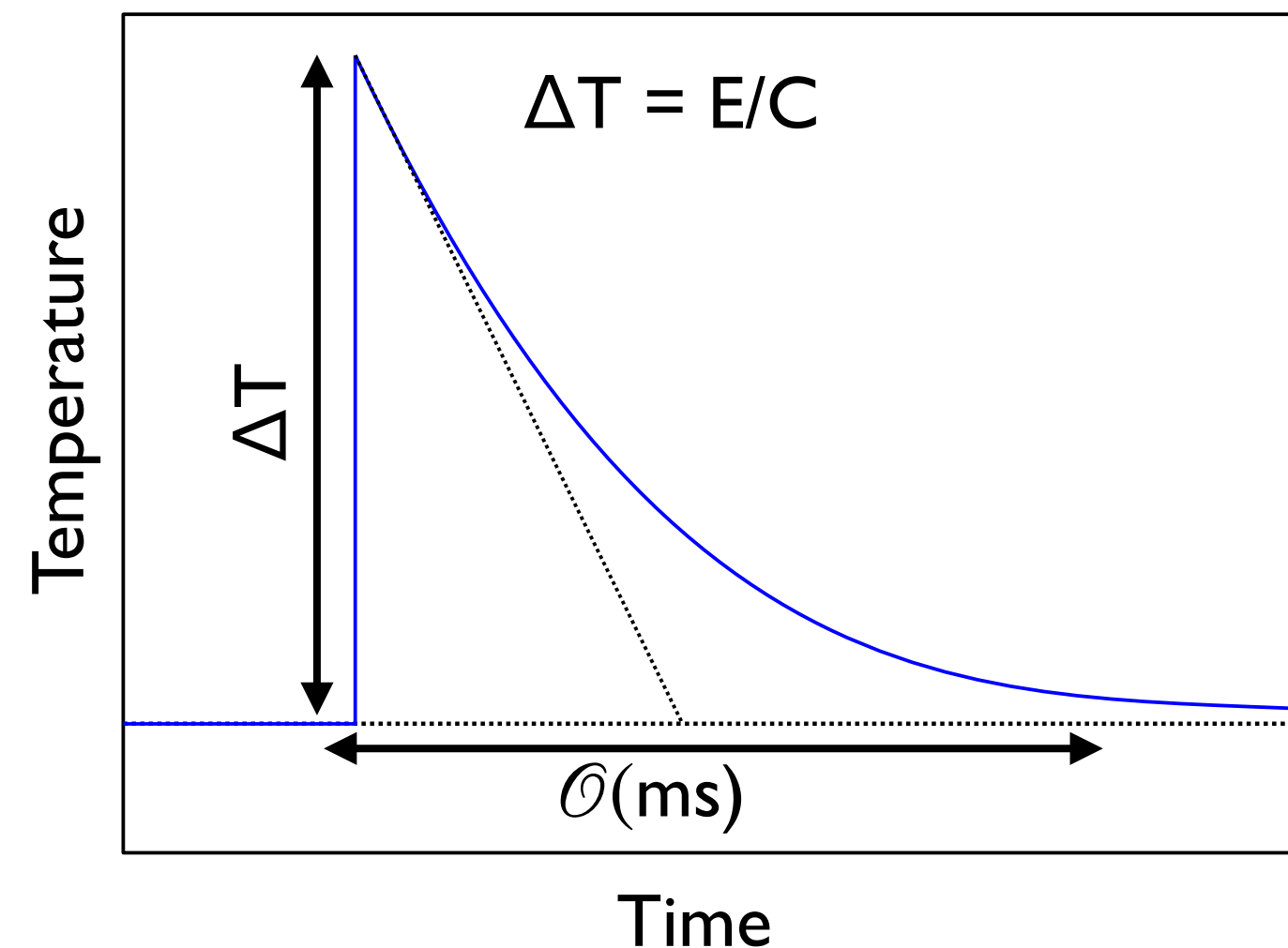
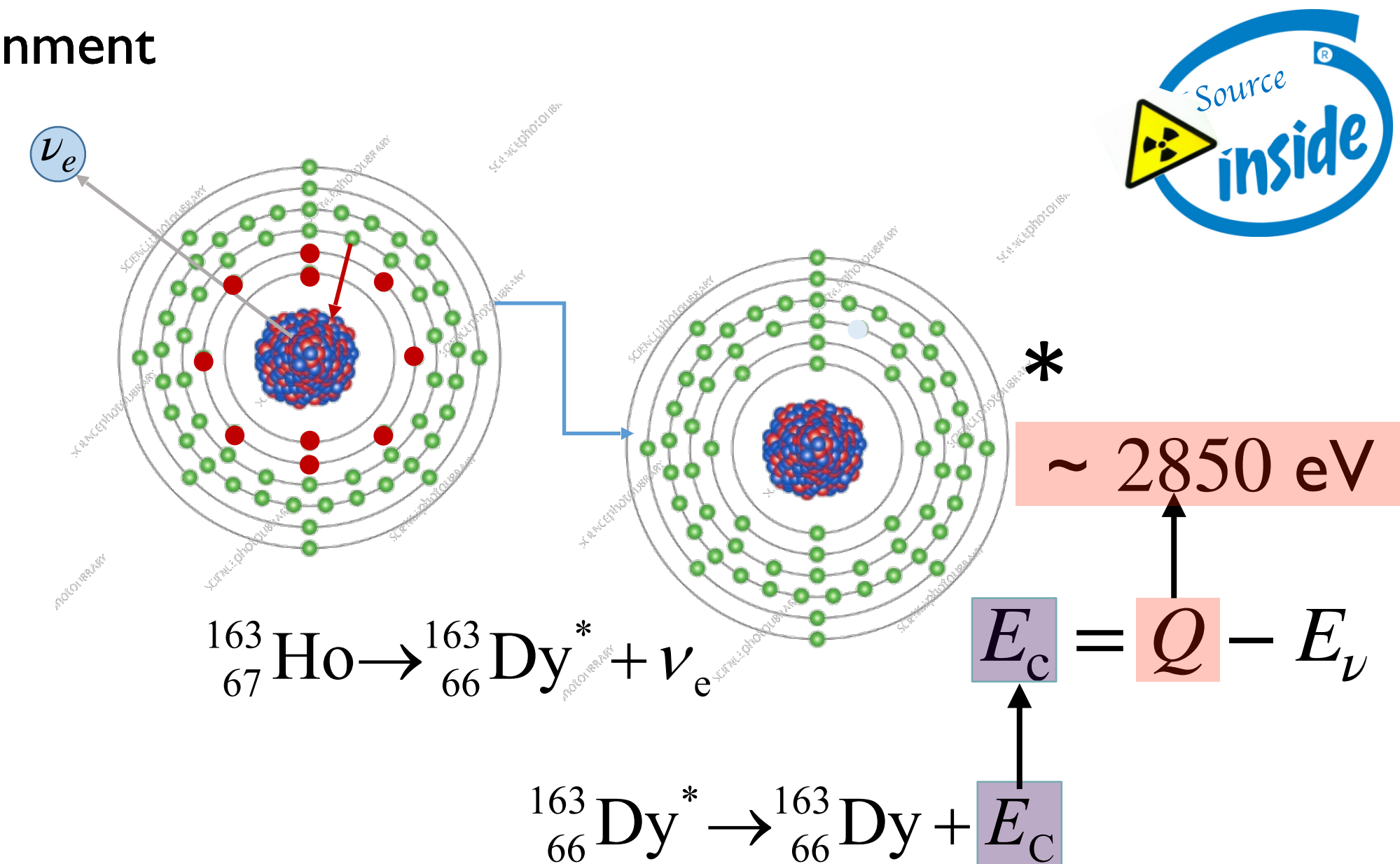

- 64 (48 active) pixels with implanted ^{163}Ho total activity of 15 Bq
- Experiment duration: 2 months
- Spectrum with 6×10^7 events (above 300 eV)
- Energy resolution $\langle \Delta E_{\text{FWHM}} \rangle = 6 \pm 1$ eV
- Background rate: $1.7 \pm 0.1 \times 10^{-4}$ events/(eV·pixel·day)

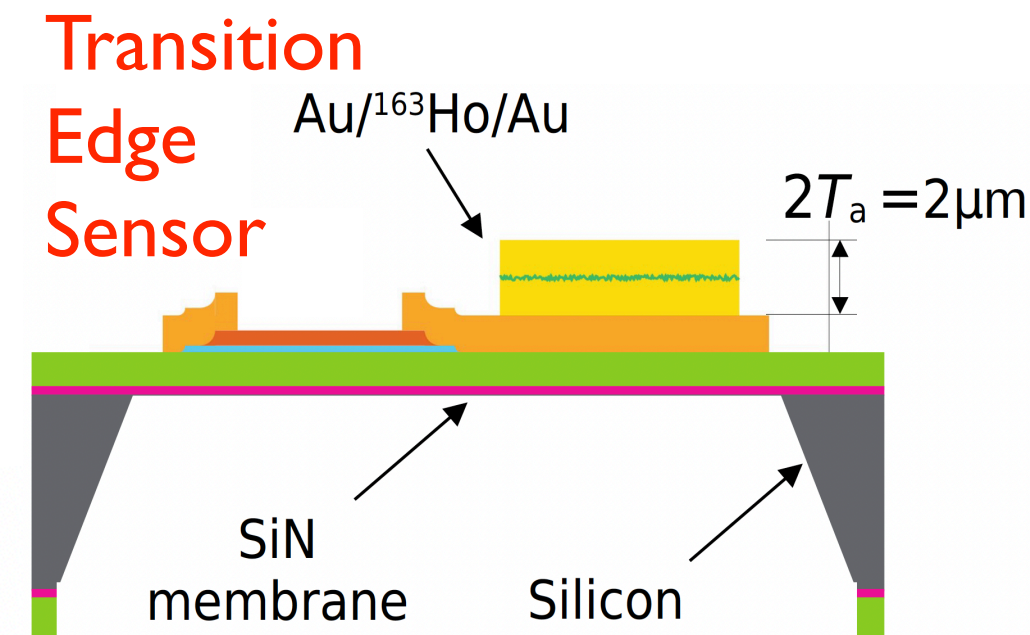
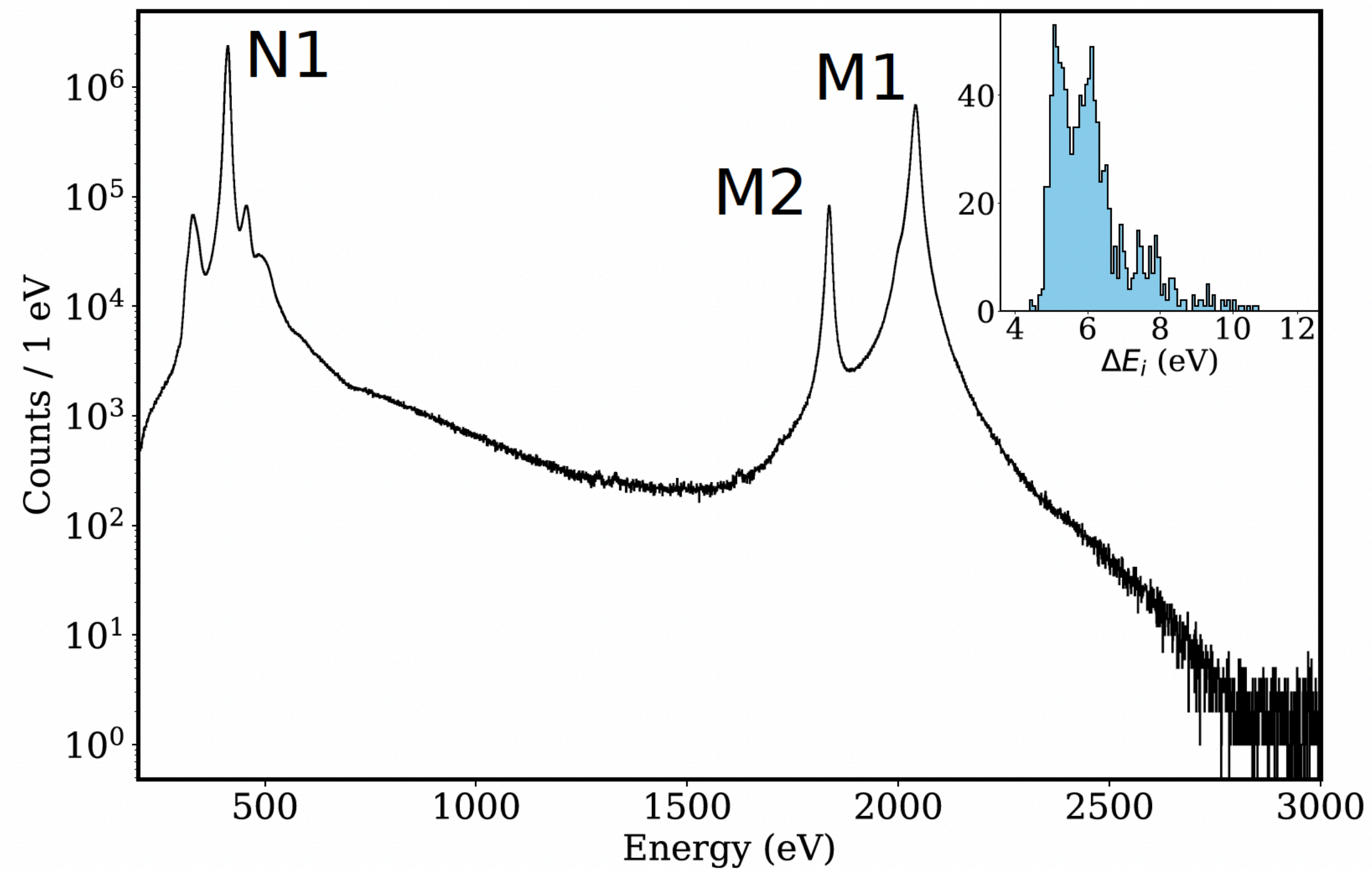

- 64 (48 active) pixels with implanted ^{163}Ho total activity of 15 Bq
- Experiment duration: 2 months
- Spectrum with 6×10^7 events (above 300 eV)
- Energy resolution $\langle \Delta E_{\text{FWHM}} \rangle = 6 \pm 1$ eV
- Background rate: $1.7 \pm 0.1 \times 10^{-4}$ events/(eV·pixel·day)

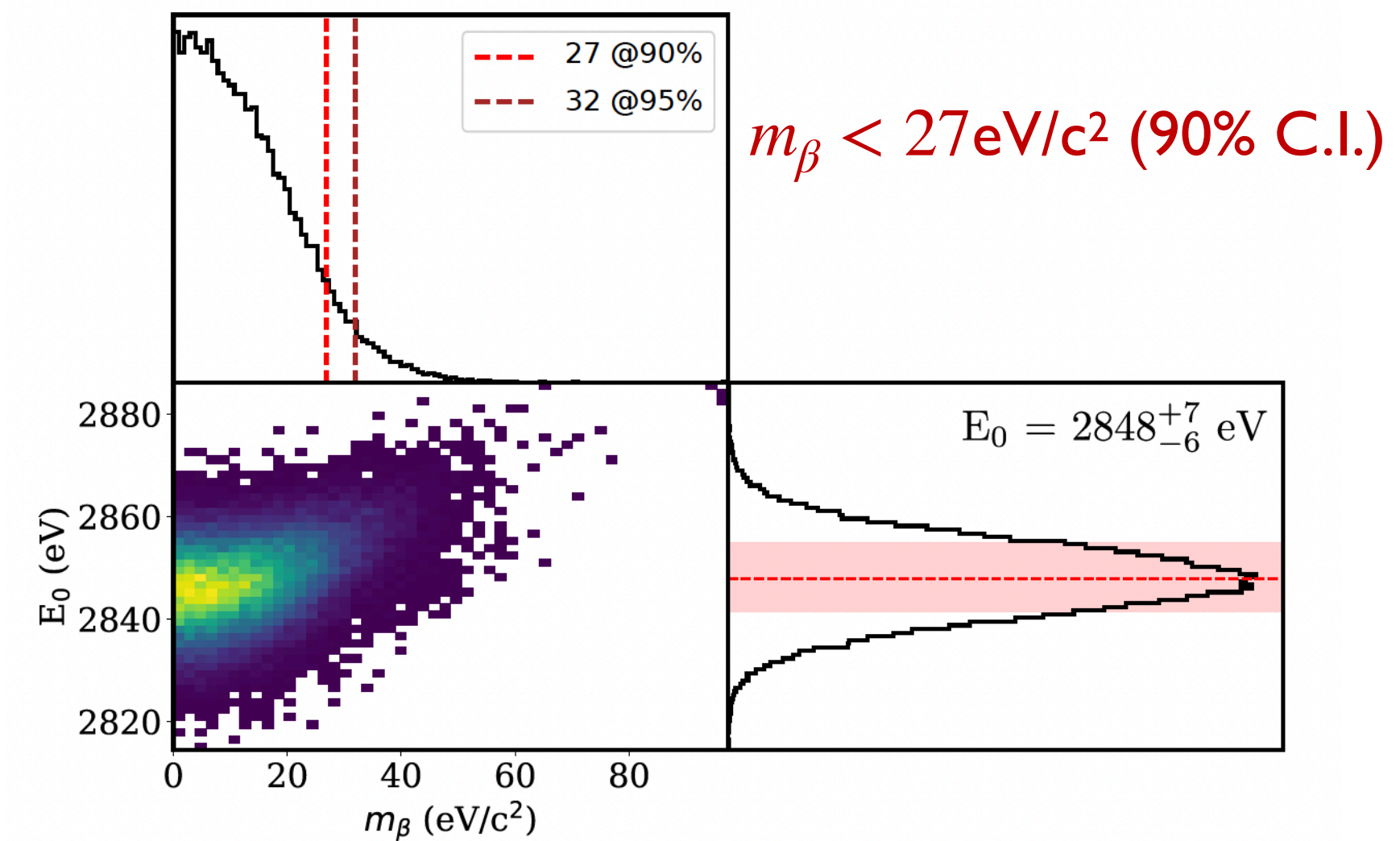
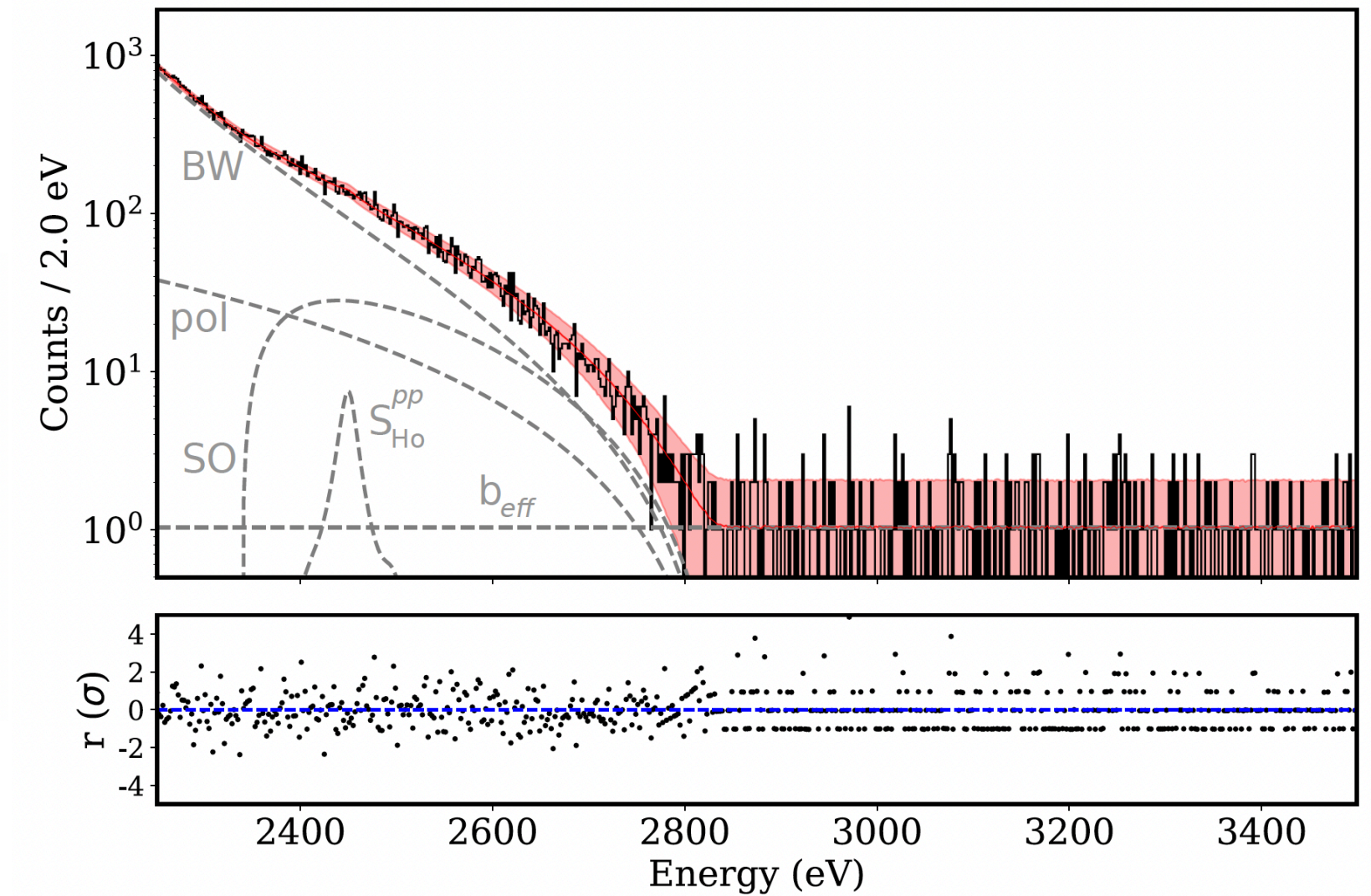
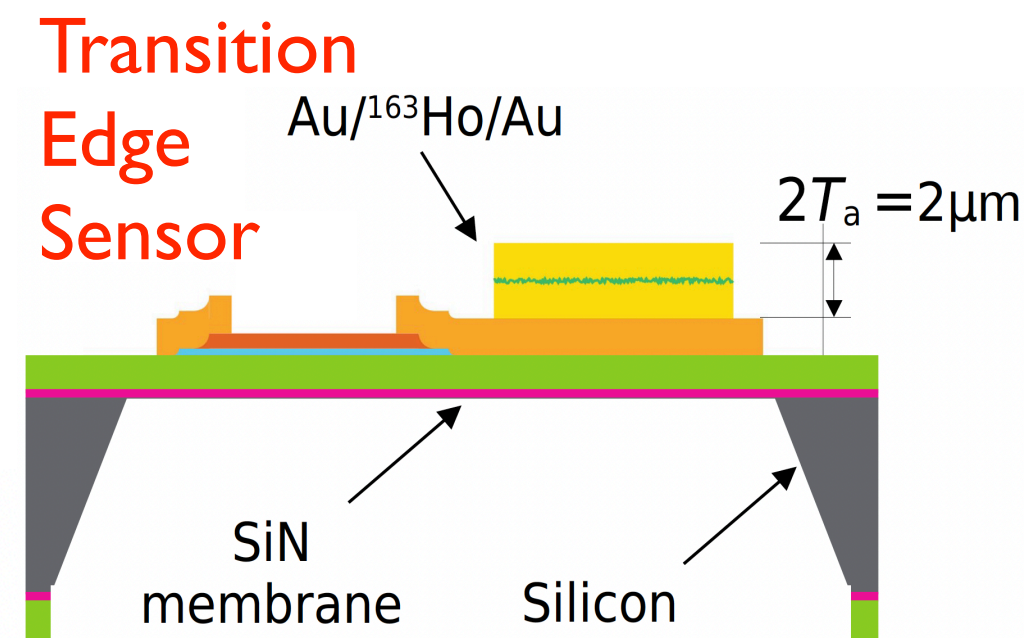
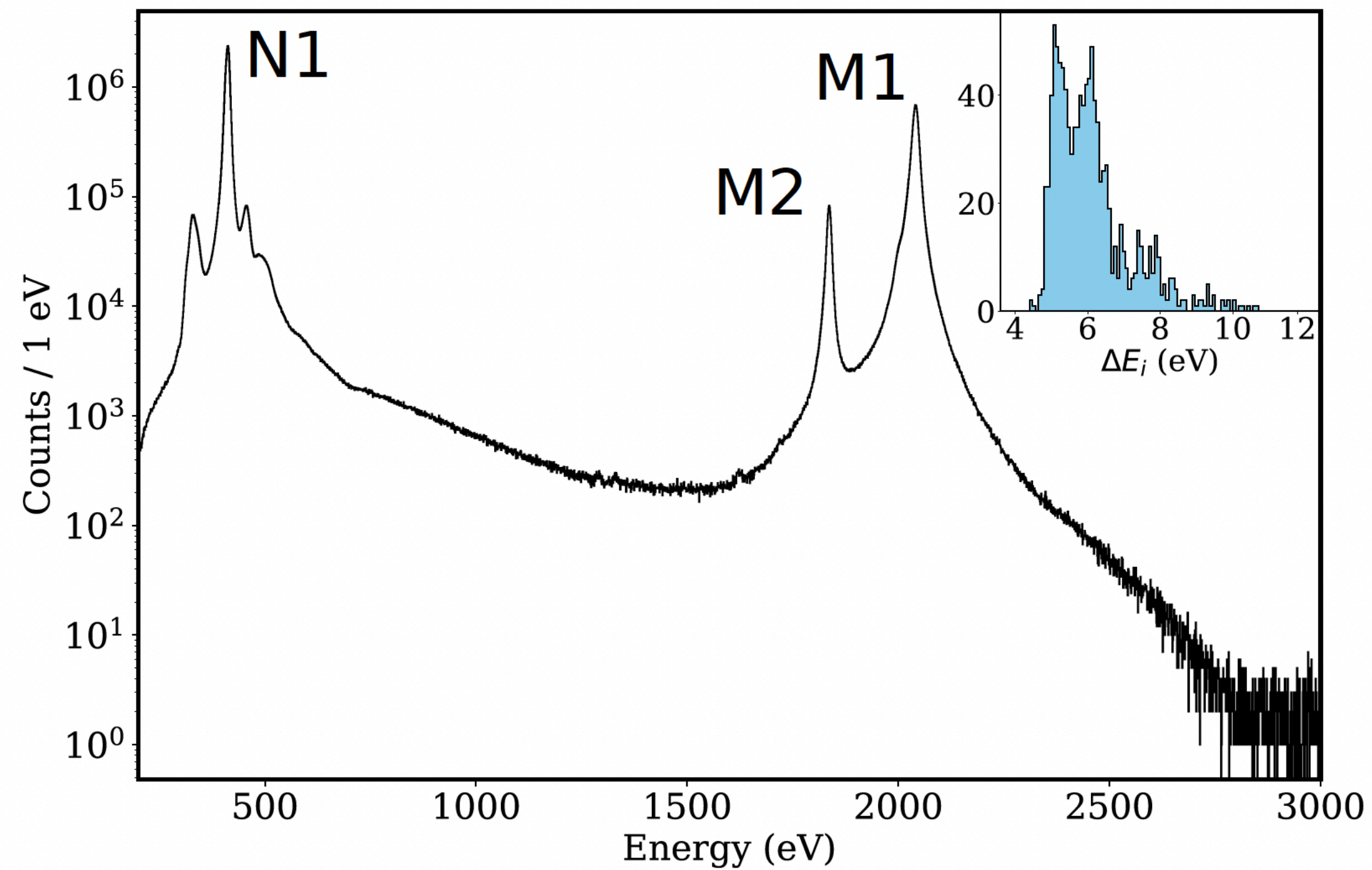

- 64 (48 active) pixels with implanted ^{163}Ho total activity of 15 Bq
- Experiment duration: 2 months
- Spectrum with 6×10^7 events (above 300 eV)
- Energy resolution $\langle \Delta E_{\text{FWHM}} \rangle = 6 \pm 1$ eV
- Background rate: $1.7 \pm 0.1 \times 10^{-4}$ events/(eV·pixel·day)

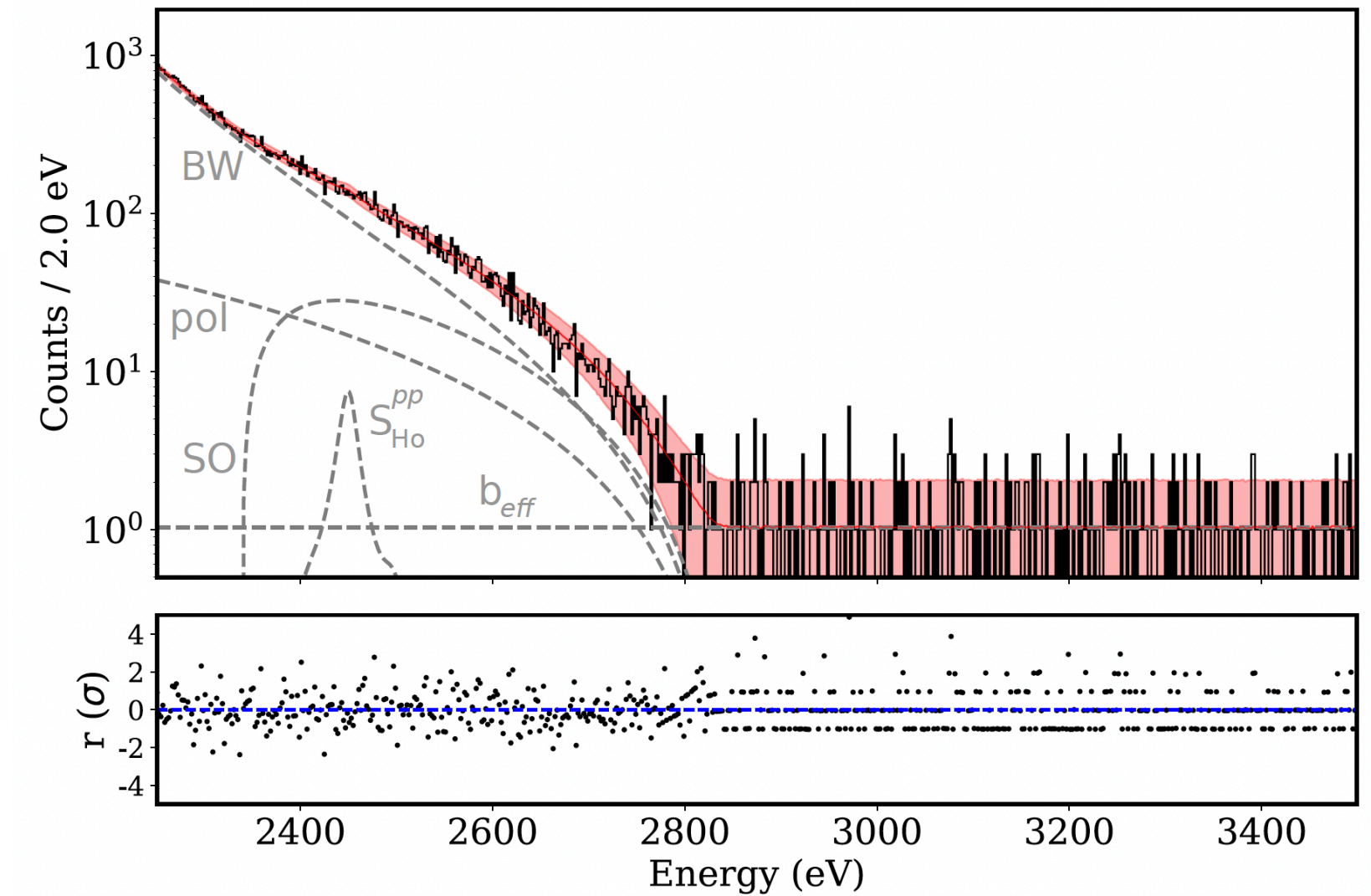
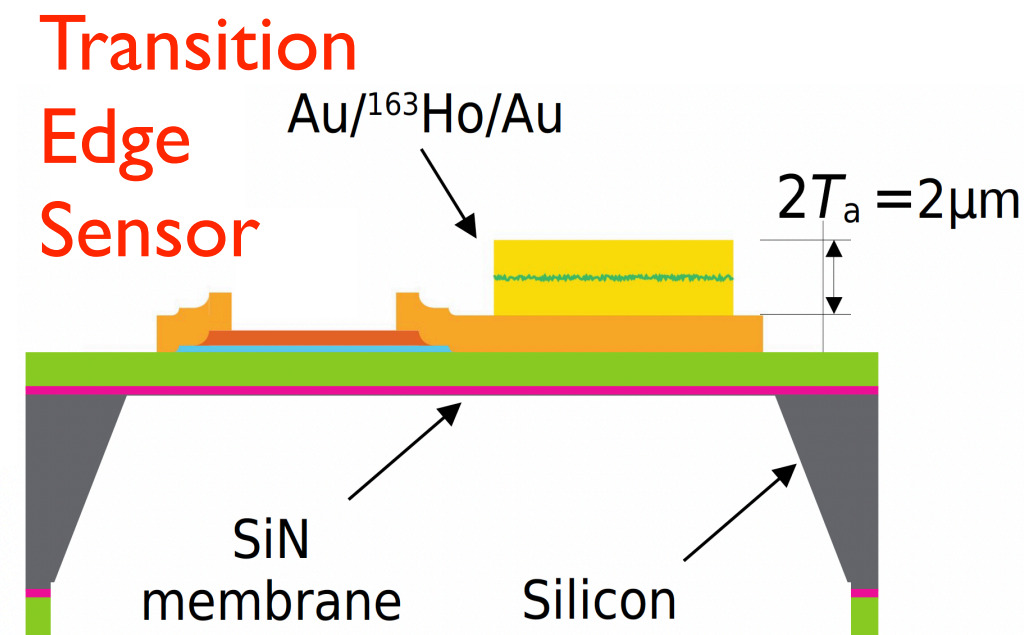

PHYSICAL REVIEW LETTERS 135, 141801 (2025)

Editors' Suggestion

Most Stringent Bound on Electron Neutrino Mass Obtained with a Scalable Low-Temperature Microcalorimeter Array

B. K. Alpert¹, M. Balata², D. T. Becker³, D. A. Bennett¹, M. Borghesi^{4,5,*}, P. Campana^{4,5}, R. Carobene^{4,5}, M. De Gerone⁶, W. B. Doriese¹, M. Favazzani^{4,5}, L. Ferrari Barusso^{7,6}, E. Ferri⁵, J. W. Fowler¹, G. Gallucci⁶, S. Gamba^{4,5}, J. D. Gard³, F. Gatti^{7,6}, A. Giachero^{4,5}, M. Gobbo^{4,5}, U. Köster⁸, D. Labranca^{4,5}, M. Lusignoli^{9,10}, P. Manfrinetti¹¹, J. A. B. Mates¹, E. Maugeri¹², R. Moretti^{4,5}, S. Nisi², A. Nucciotti^{4,5,†}, G. C. O'Neil¹, L. Origo^{4,5}, G. Pessina⁵, S. Ragazzi^{4,5}, C. D. Reintsema¹, D. R. Schmidt^{1,‡}, D. Schumann¹², D. S. Swetz¹, Z. Talip¹², J. N. Ullom^{1,§} and L. R. Vale¹

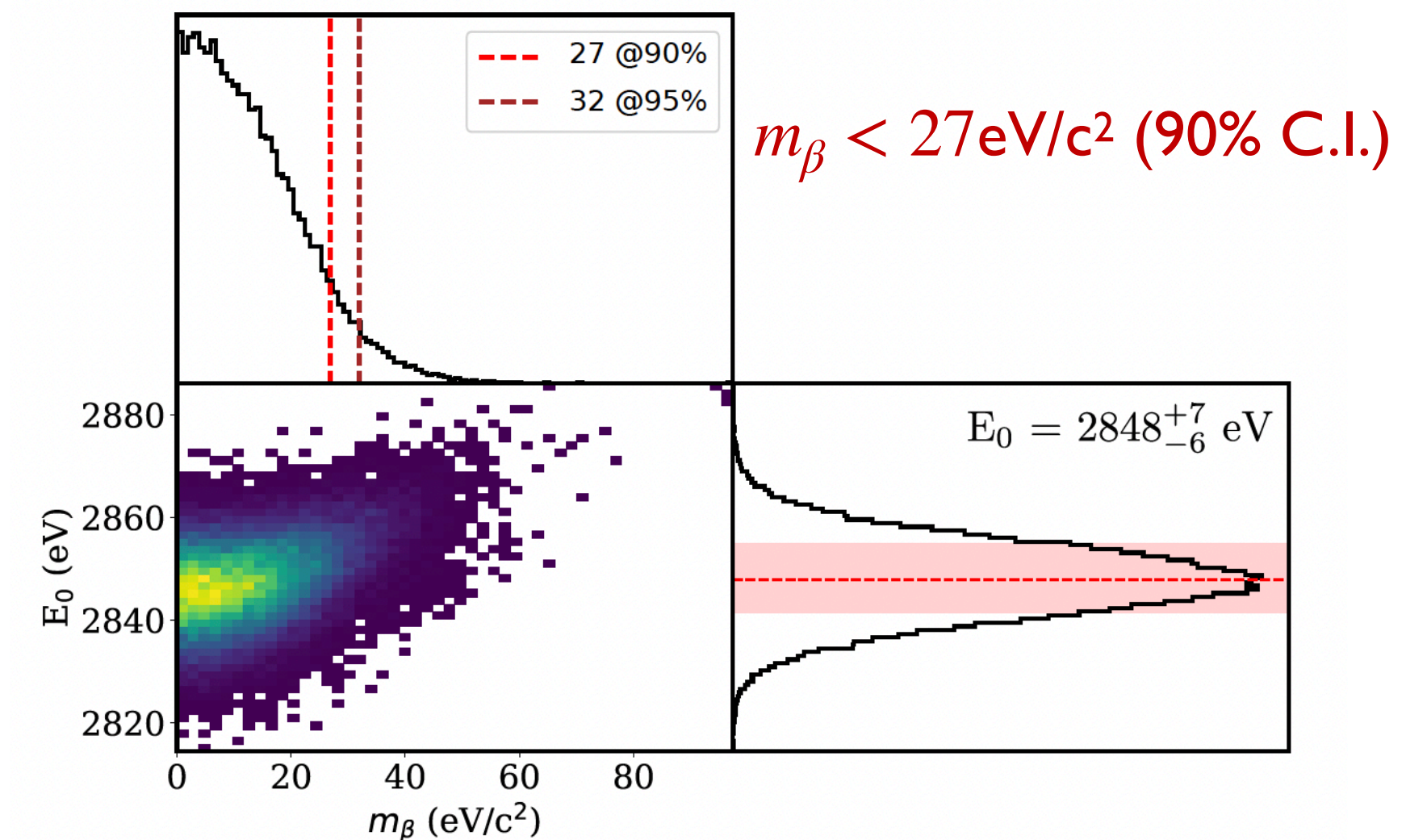

- 64 (48 active) pixels with implanted ^{163}Ho total activity of 15 Bq
- Experiment duration: 2 months
- Spectrum with 6×10^7 events (above 300 eV)
- Energy resolution $\langle \Delta E_{\text{FWHM}} \rangle = 6 \pm 1$ eV
- Background rate: $1.7 \pm 0.1 \times 10^{-4}$ events/(eV·pixel·day)

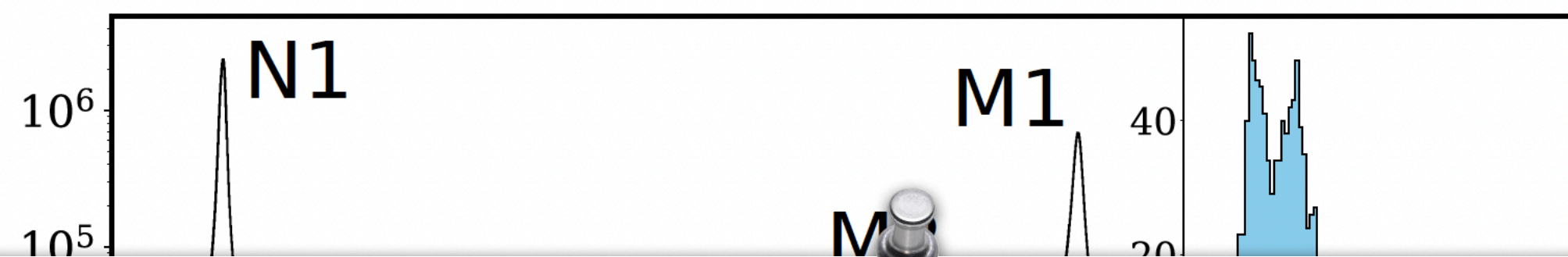
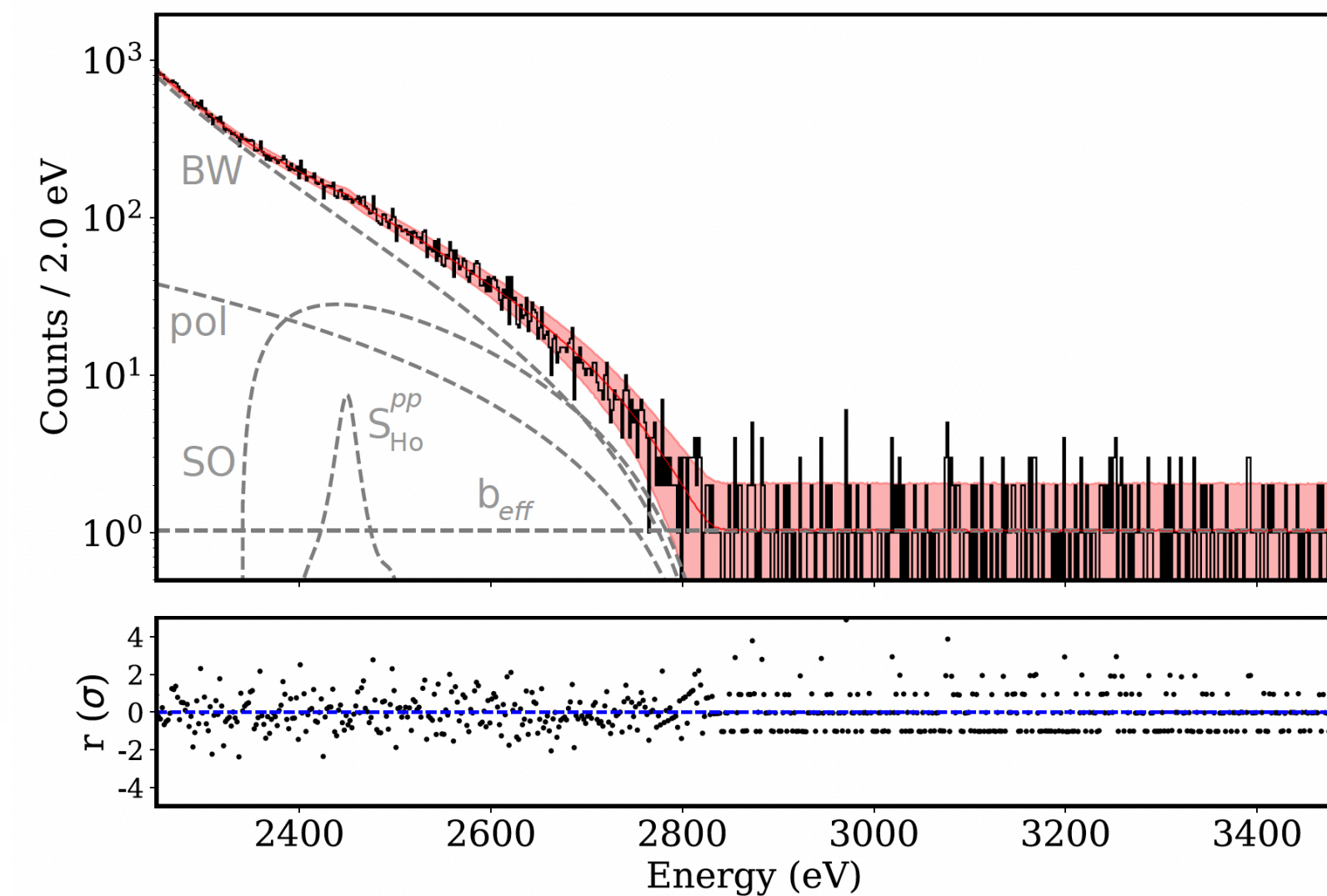
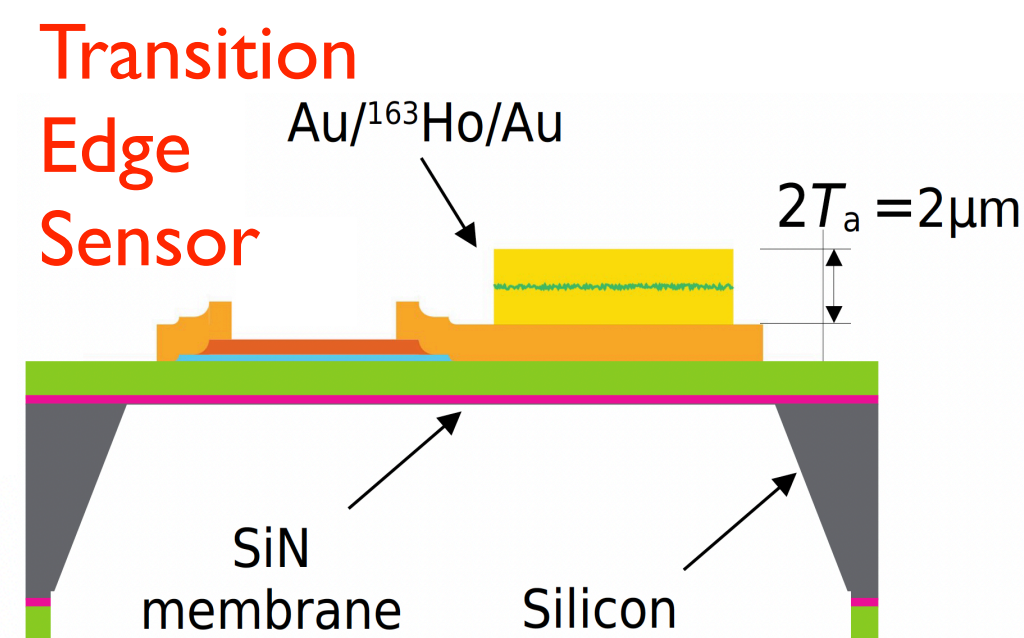

PHYSICAL REVIEW LETTERS 135, 141801 (2025)

Editors' Suggestion

Most Stringent Bound on Electron Neutrino Mass Obtained with a Scalable Low-Temperature Microcalorimeter Array

B. K. Alpert¹, M. Balata², D. T. Becker³, D. A. Bennett¹, M. Borghesi^{4,5,*}, P. Campana^{4,5}, R. Carobene^{4,5}, M. De Gerone⁶, W. B. Doriese¹, M. Faverzani^{4,5}, L. Ferrari Barusso^{7,6}, E. Ferri⁵, J. W. Fowler¹, G. Gallucci⁶, S. Gamba^{4,5}, J. D. Gard³, F. Gatti^{7,6}, A. Giachero^{4,5}, M. Gobbo^{4,5}, U. Köster⁸, D. Labranca^{4,5}, M. Lusignoli^{9,10}, P. Manfrinetti¹¹, J. A. B. Mates¹, E. Maugeri¹², R. Moretti^{4,5}, S. Nisi², A. Nucciotti^{4,5,†}, G. C. O'Neil¹, L. Origo^{4,5}, G. Pessina⁵, S. Ragazzi^{4,5}, C. D. Reintsema¹, D. R. Schmidt^{1,‡}, D. Schumann¹², D. S. Swetz¹, Z. Talip¹², J. N. Ullom^{1,§} and L. R. Vale¹

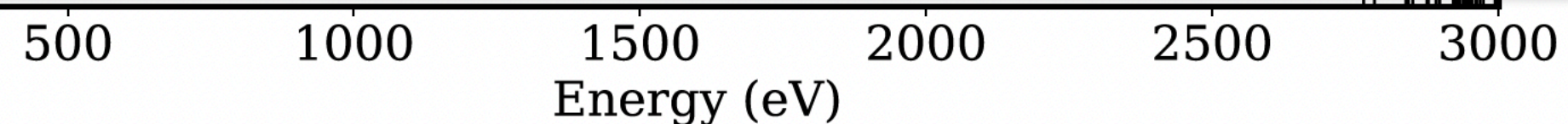

Improved analysis with better spectral modeling ongoing

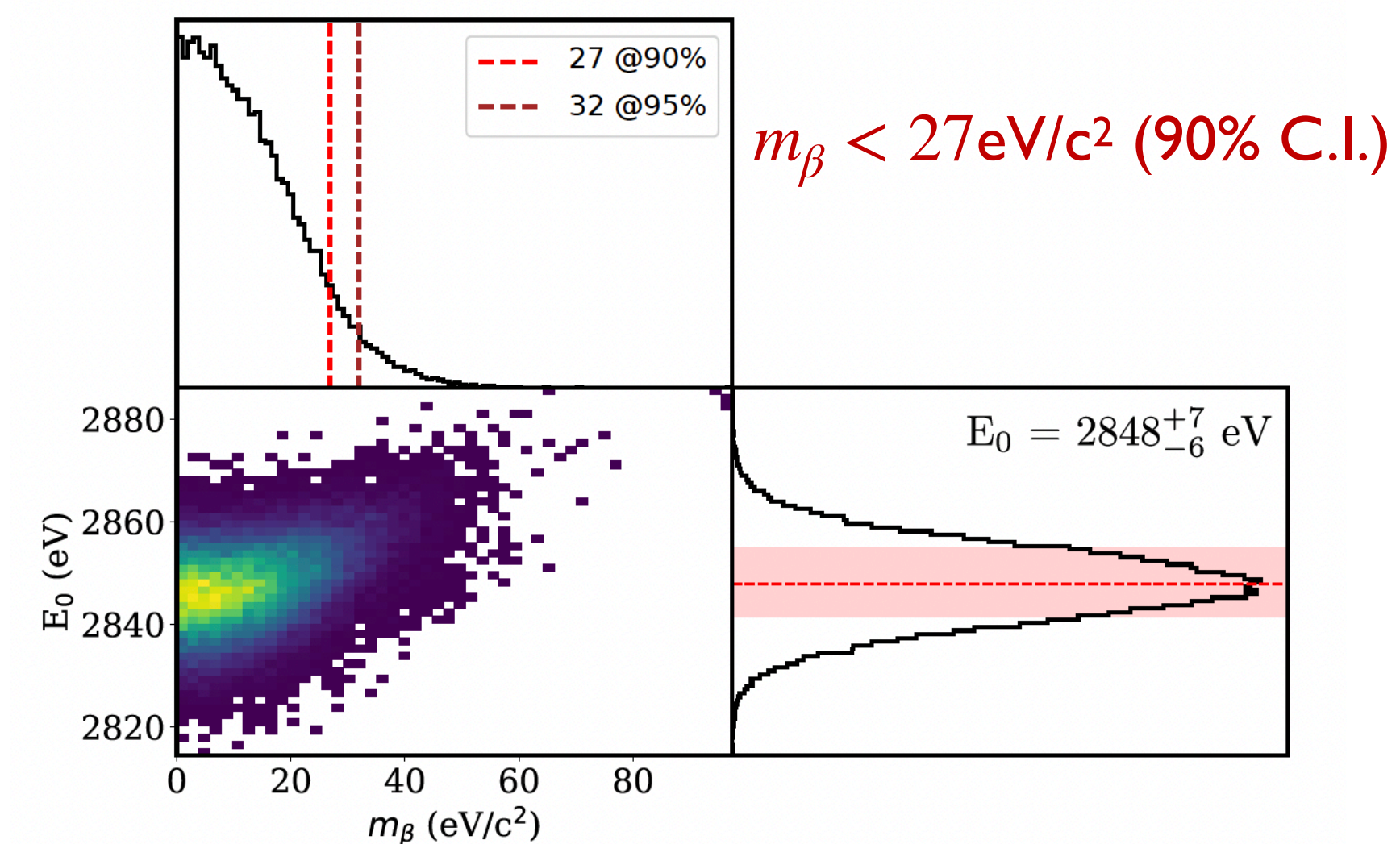



Prototypes to demonstrate scalability

improve ion implanter for better control and higher efficiency → up to few 10%

- now integrating electrostatic triplet for focusing, XY stirring magnet and target chamber for co-deposition
- upgrade ion source: Forced Electron Beam Induced Arc Discharge or Resonant Laser Ionization

increase ^{163}Ho activity per detector → up to $\mathcal{O}(10 \text{ Bq})$

- reduce detector operating temperature to $\lesssim 50\text{mK}$
- implement Au co-deposition

reduce readout/DAQ cost → few € per channel

- new multiplexing scheme w/o rfSQUIDs and larger multiplexing factor
- leverage new large bandwidth RFSoc boards

enlarge the international collaboration

256-pixel array with rfSQUID μmux

ZCU216 RFSoc

$\approx 3 \text{ Bq}(^{163}\text{Ho})/\text{pixel}$

$\Delta E_{\text{FWHM}} \approx 5 \text{ eV}$ and $\tau_{\text{R}} \approx 1 \mu\text{s}$

→ $m_{\nu} < 5.6 \text{ (8.6) eV}$ in 2 y (2 months)

16-pixel array with KICS μmux

ZCU216 RFSoc

$\approx 30 \text{ Bq}(^{163}\text{Ho})/\text{pixel}$

$\Delta E_{\text{FWHM}} \approx 5 \text{ eV}$ and $\tau_{\text{R}} \approx 0.1 \mu\text{s}$

→ $m_{\nu} < 3.6 \text{ (6.6) eV}$ in 2 y (2 months)

Slide from A. Nucciotti (NuMass 2026)

- 57 pixel with implanted ^{163}Ho total activity of 46 Bq
- 9 background pixels
- Experiment duration: 6 months
- Spectrum with 2×10^8 events (above 100 eV)
- Energy resolution $\Delta E_{FWHM} = 6.95 \pm 0.16$ eV (MII line)
- Background rate: $9.1 \pm 1.3 \times 10^{-6}$ events/(eV·pixel·day)

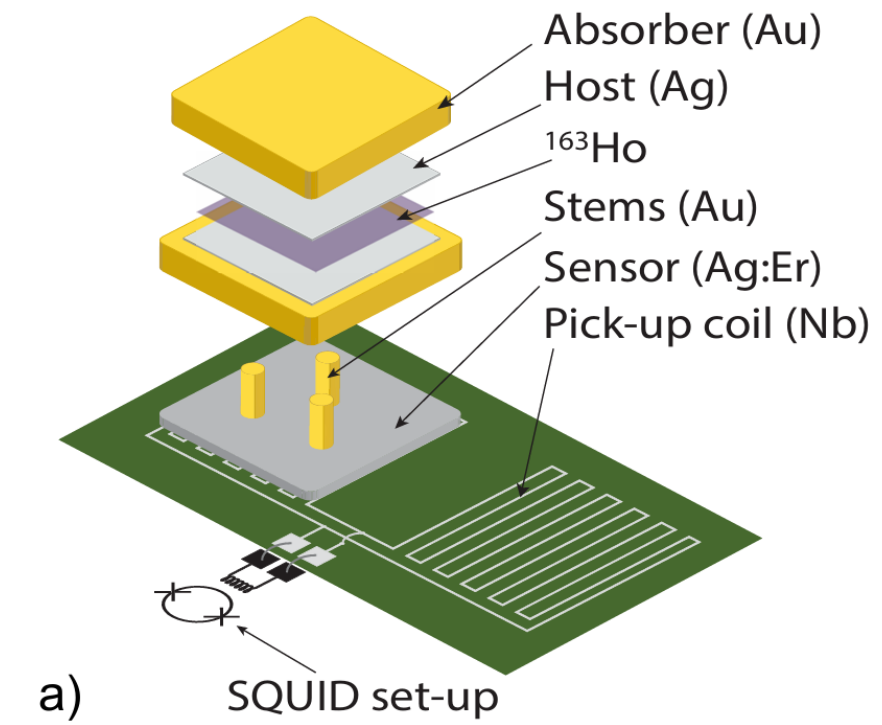

Metallic
Magnetic
Calorimeter

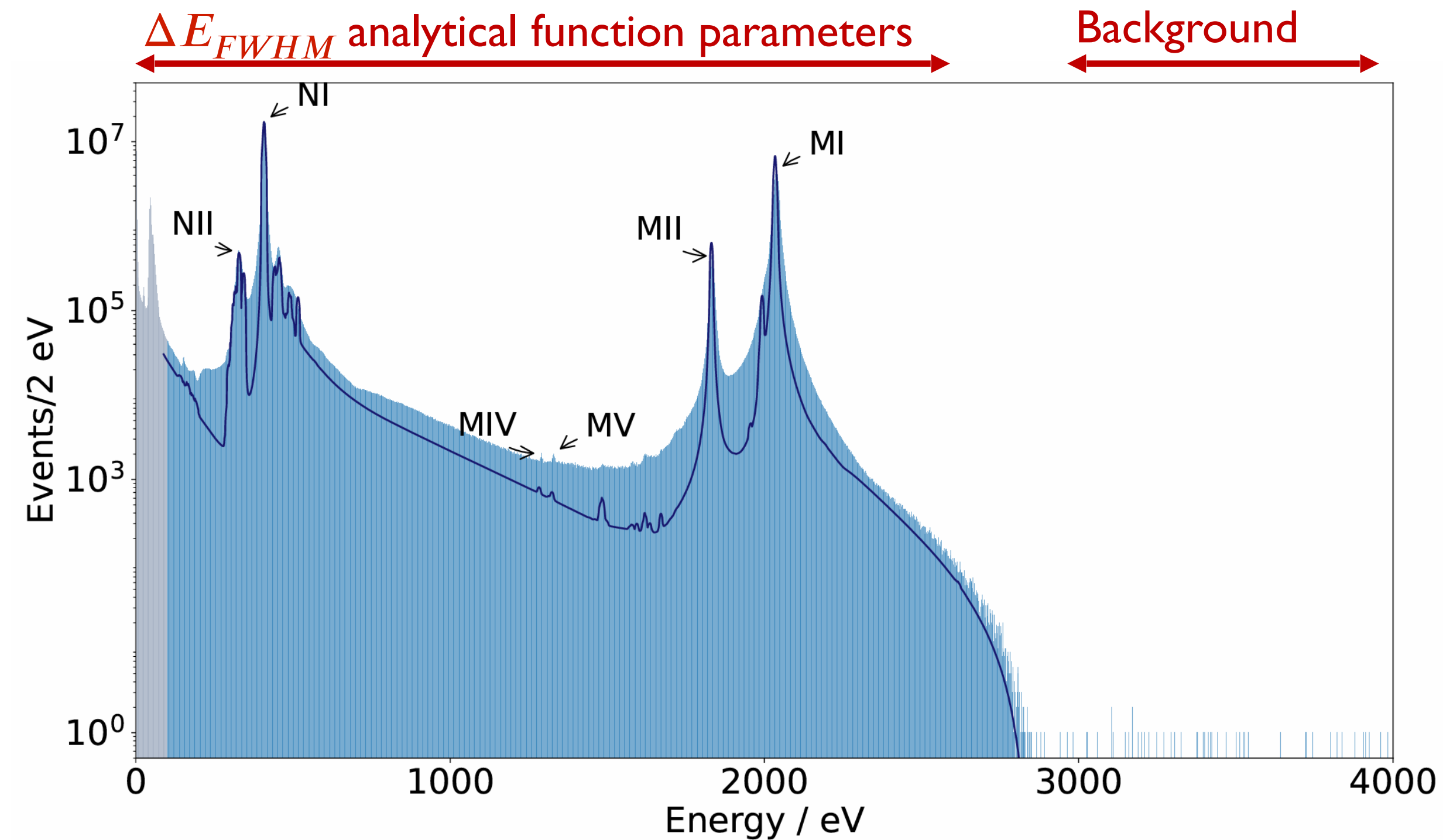

Courtesy of L. Gastaldo

- 57 pixel with implanted ^{163}Ho total activity of 46 Bq
- 9 background pixels
- Experiment duration: 6 months
- Spectrum with 2×10^8 events (above 100 eV)
- Energy resolution $\Delta E_{FWHM} = 6.95 \pm 0.16$ eV (MII line)
- Background rate: $9.1 \pm 1.3 \times 10^{-6}$ events/(eV·pixel·day)

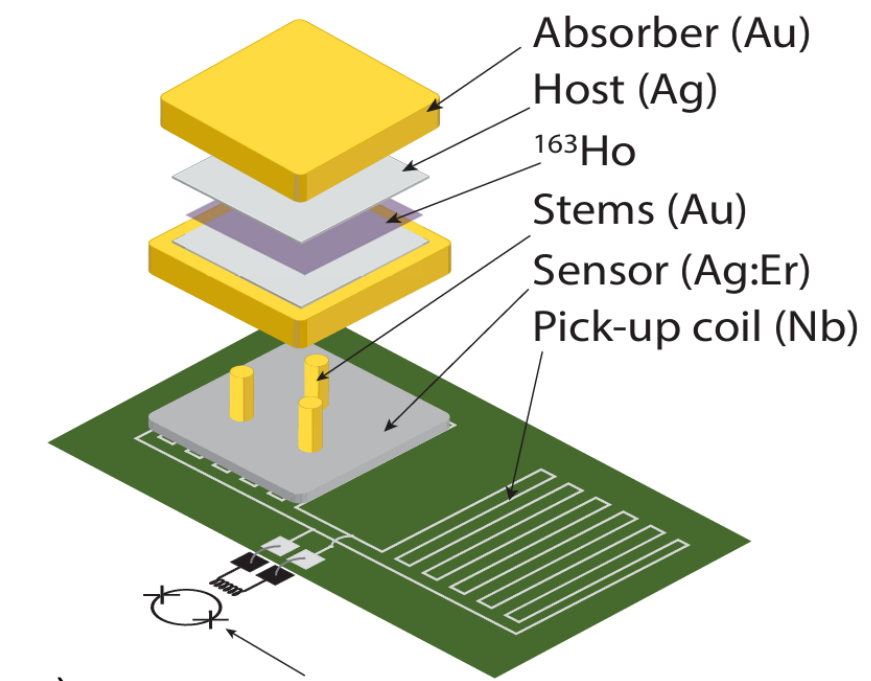

Metallic
Magnetic
Calorimeter

ΔE_{FWHM} analytical function parameters Background

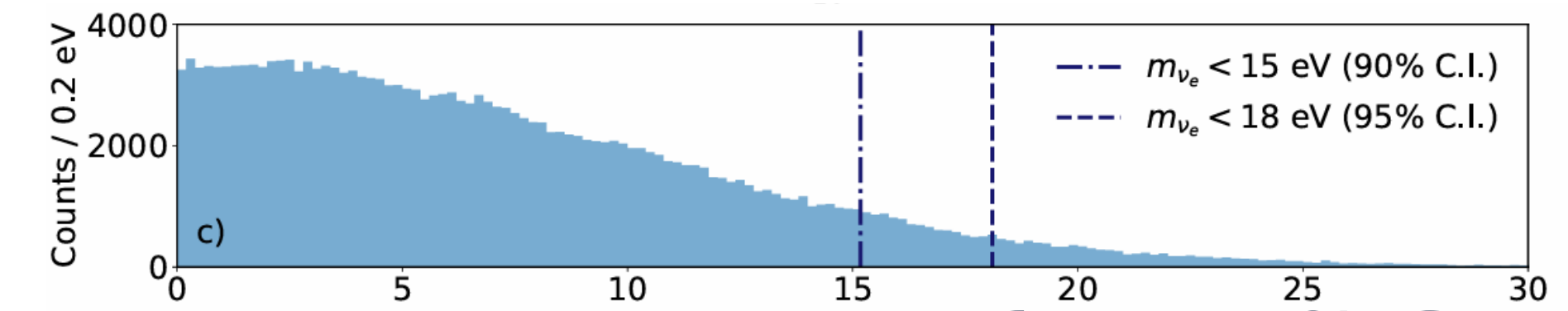
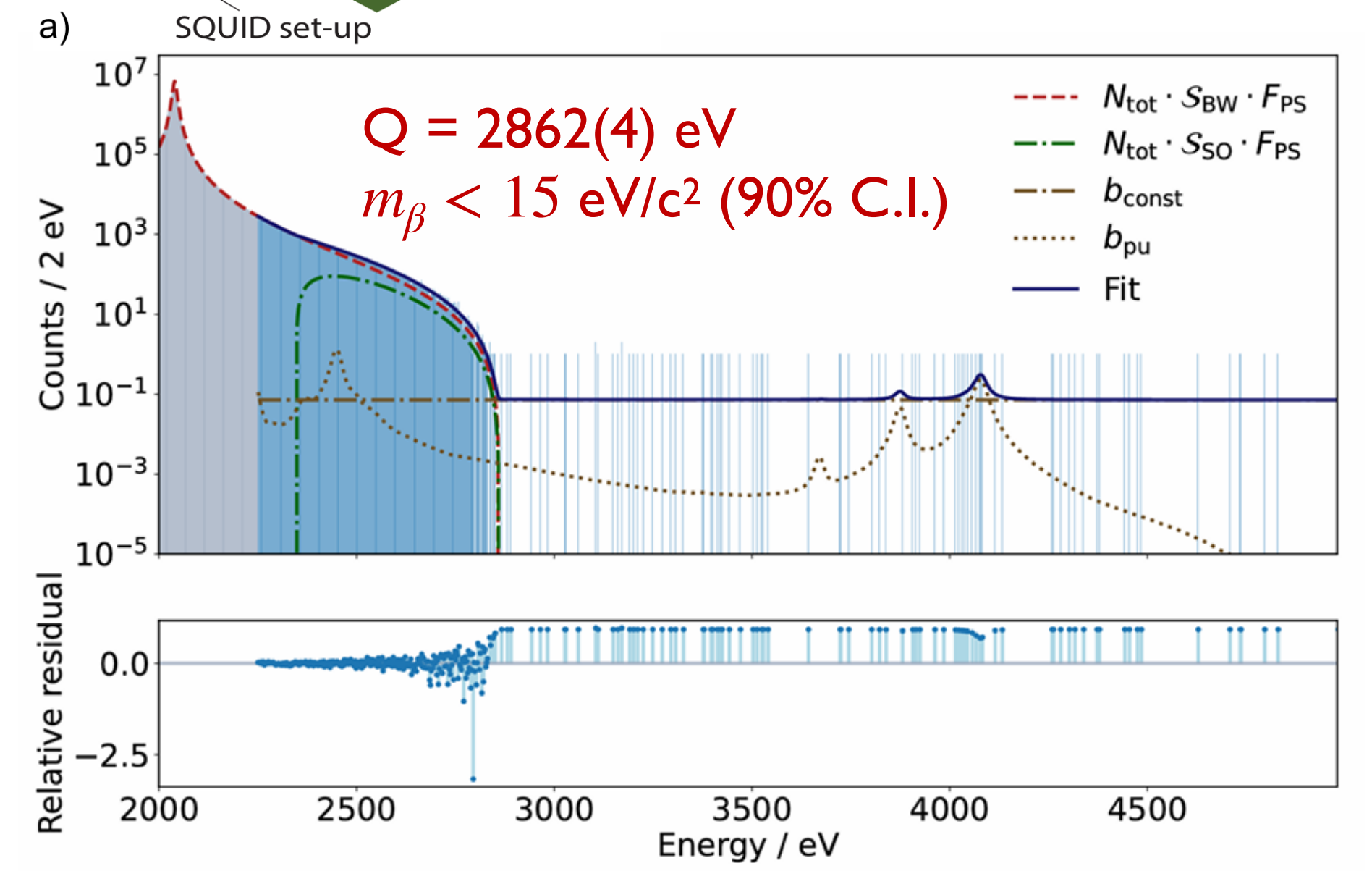
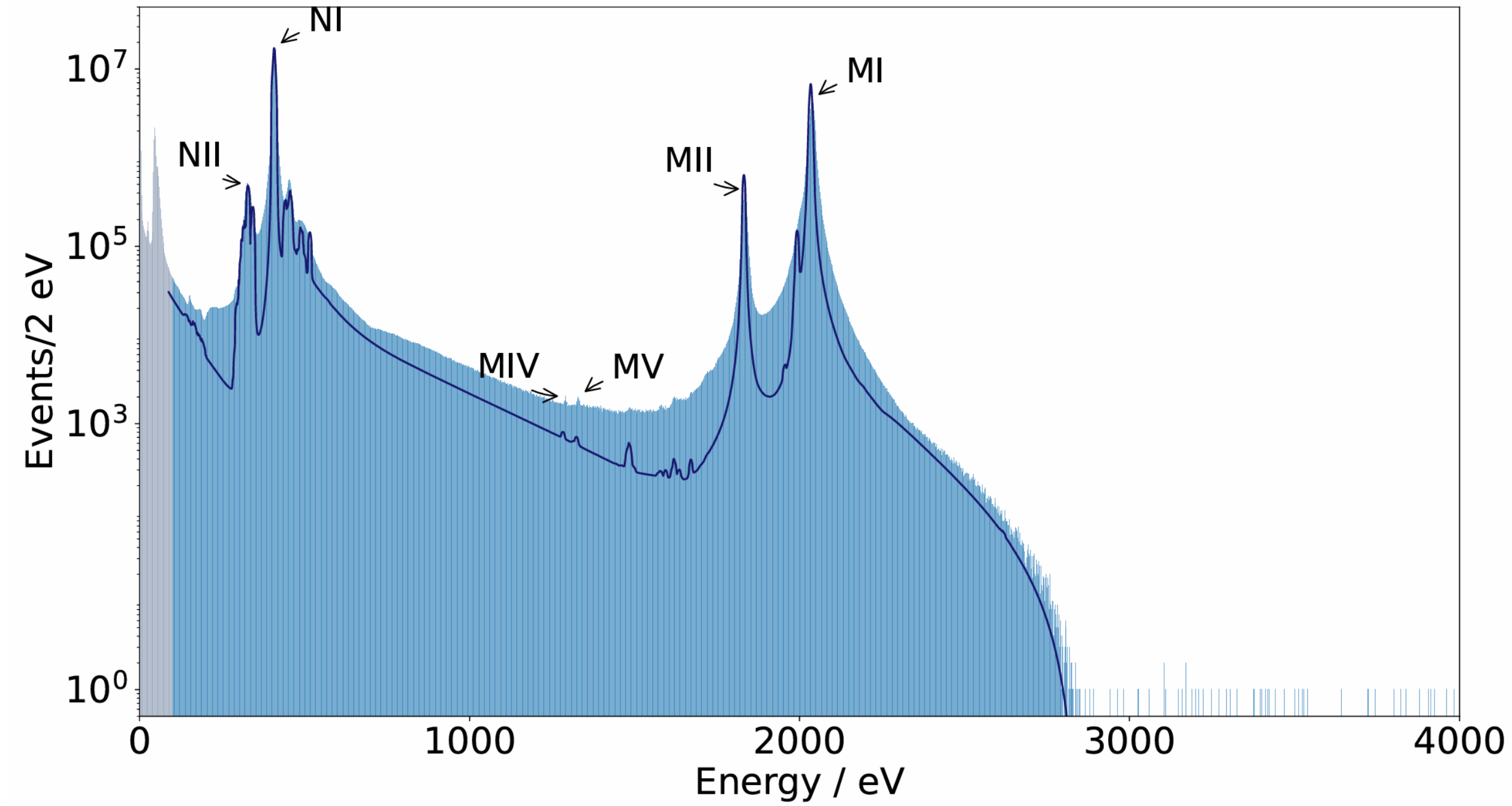

Courtesy of L. Gastaldo

- 57 pixel with implanted ^{163}Ho total activity of 46 Bq
- 9 background pixels
- Experiment duration: 6 months
- Spectrum with 2×10^8 events (above 100 eV)
- Energy resolution $\Delta E_{FWHM} = 6.95 \pm 0.16$ eV (MII line)
- Background rate: $9.1 \pm 1.3 \times 10^{-6}$ events/(eV·pixel·day)

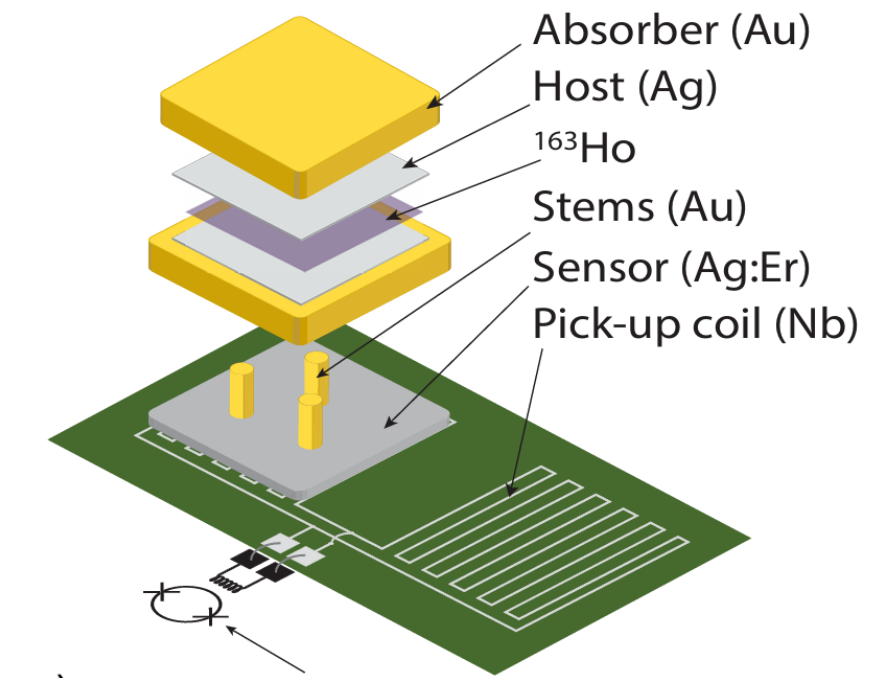

Metallic
Magnetic
Calorimeter

ΔE_{FWHM} analytical function parameters Background

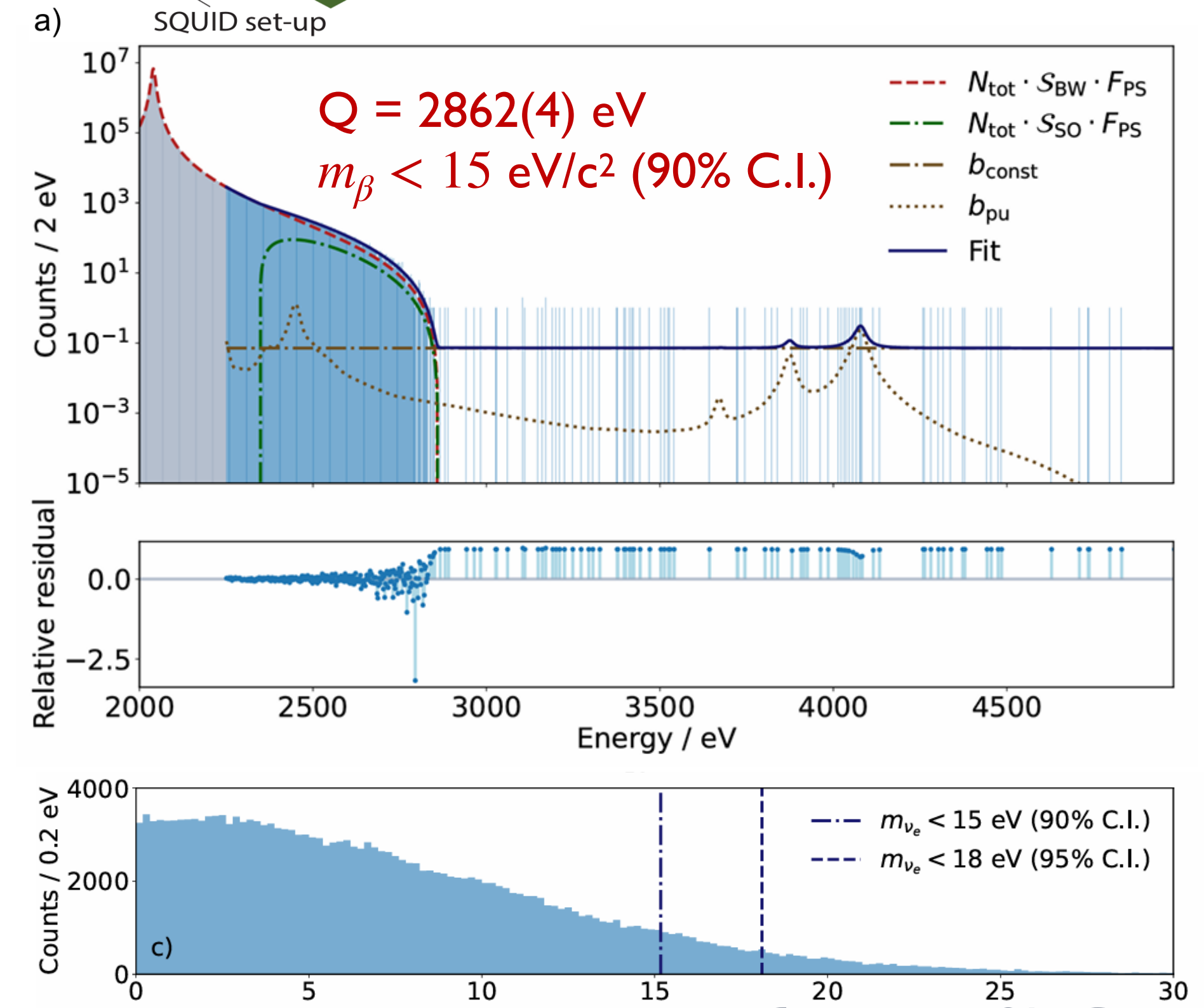
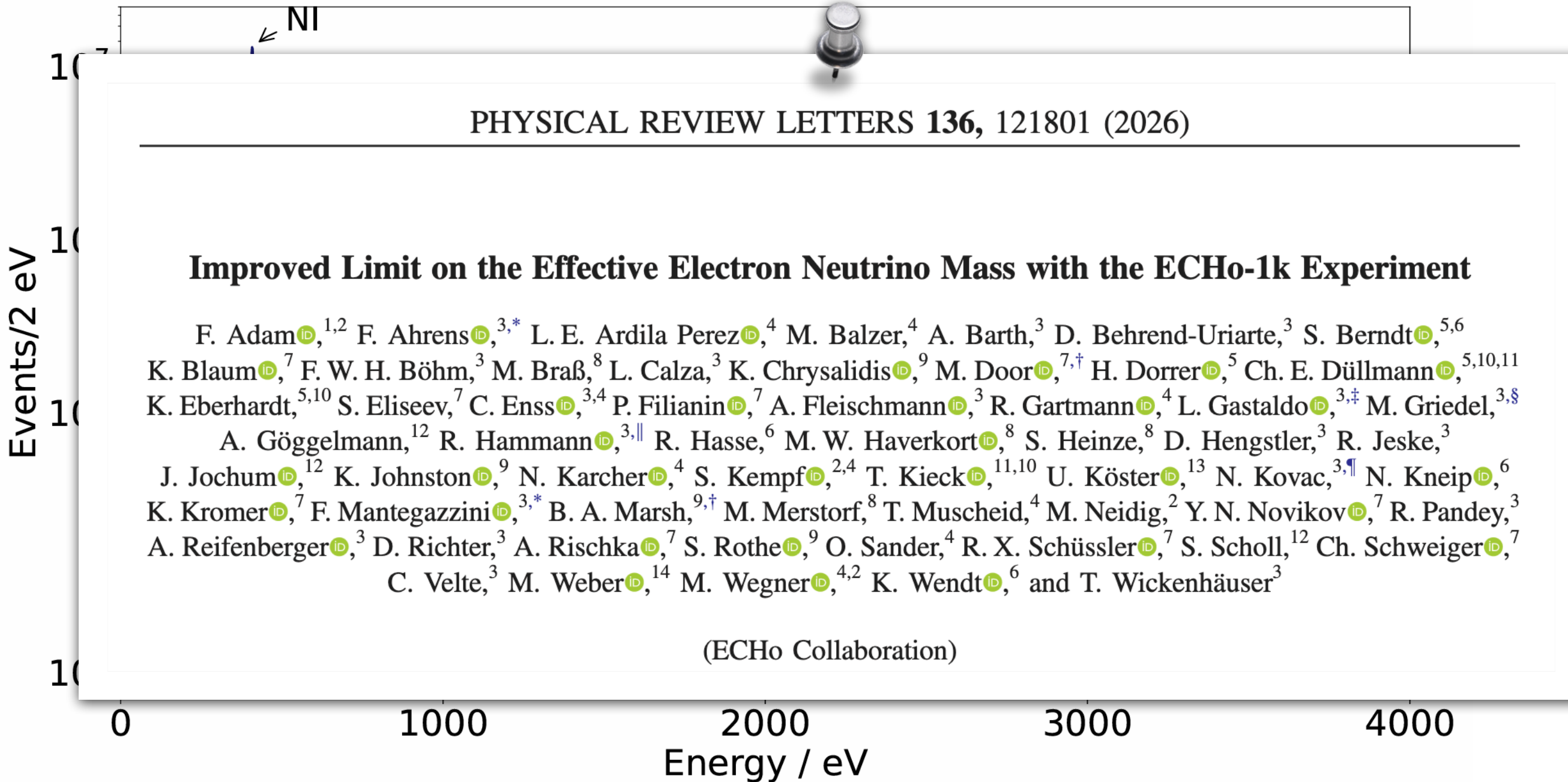

Courtesy of L. Gastaldo



ECHo-100k

Activity per pixel: 10 Bq

Number of detectors: 12000

Readout: microwave SQUID multiplexing

$m(\nu_e) < 1.5$ eV (90% C.L.)

**R&D for detector optimization
and multiplexing**

Courtesy of L. Gastaldo

ECHO-100k

Activity per pixel: 10 Bq
 Number of detectors: 12000
 Readout: microwave SQUID multiplexing
 $m(\nu_e) < 1.5 \text{ eV (90\% C.L.)}$

R&D for detector optimization and multiplexing

Multiplexed readout: microwave SQUID multiplexing
 Single HEMT amplifier and 2 coaxes to read out 400 detectors

25 cryogenic readout lines for 20000 detectors

- Full-scale readout electronics system ready for production of 15 units (12000 detectors)
- Real-time digital signal processing firmware is ready

ECHO-LE (2026 - 2030)

Activity per pixel $\sim 10 \text{ Bq/pixel}$
 Number of detectors: 20000 \rightarrow Multiplexed readout
 $\Delta E_{\text{FWHM}} < 5 \text{ eV}$
 $f_{\text{pu}} < 10^{-6}$
 $b < 10^{-6} / \text{eV/detector/day}$

Improved chip design for higher fabrication yield
 Galvanization of second absorber layer

10 wafers * 40 chips * 60 pixels

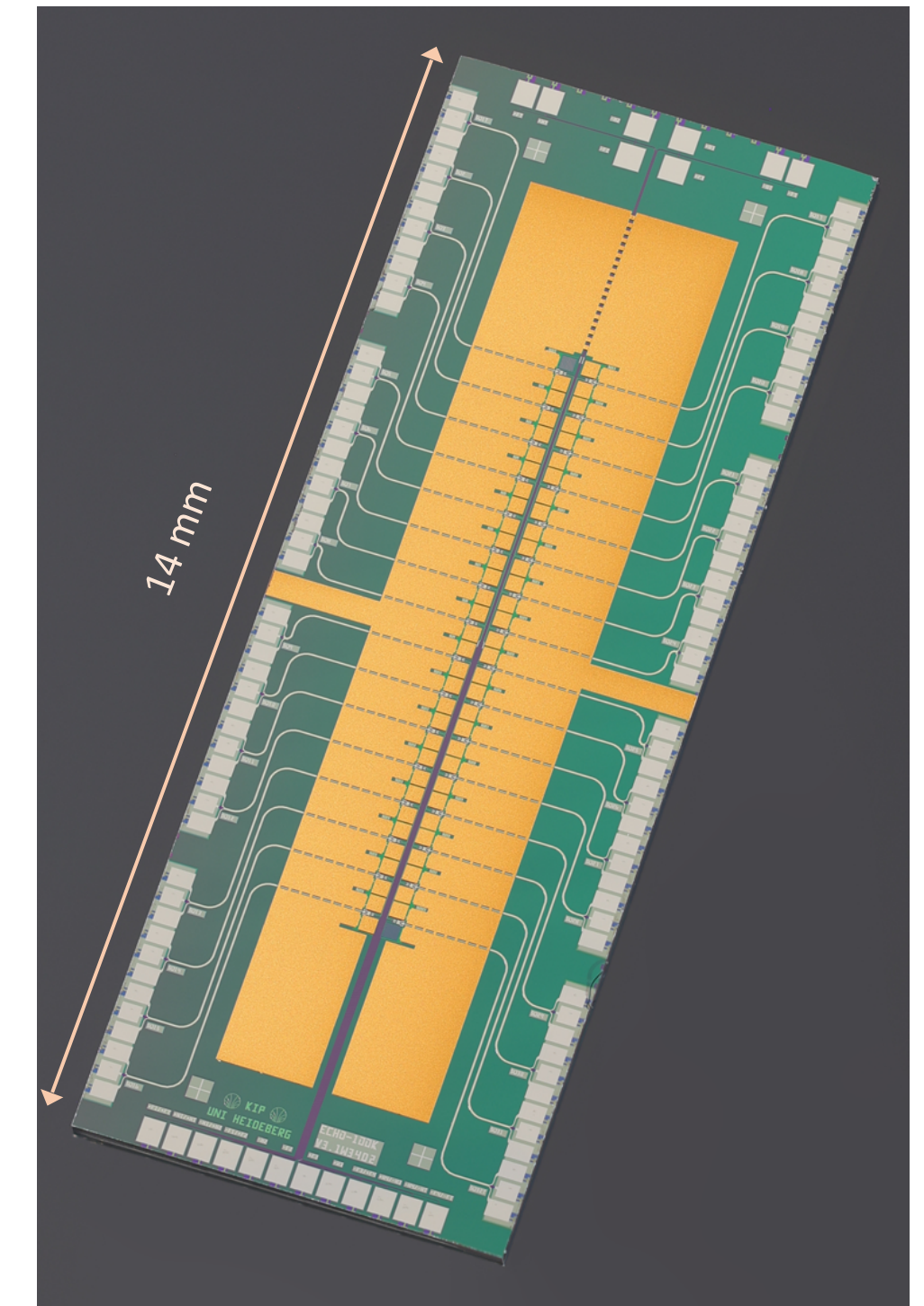
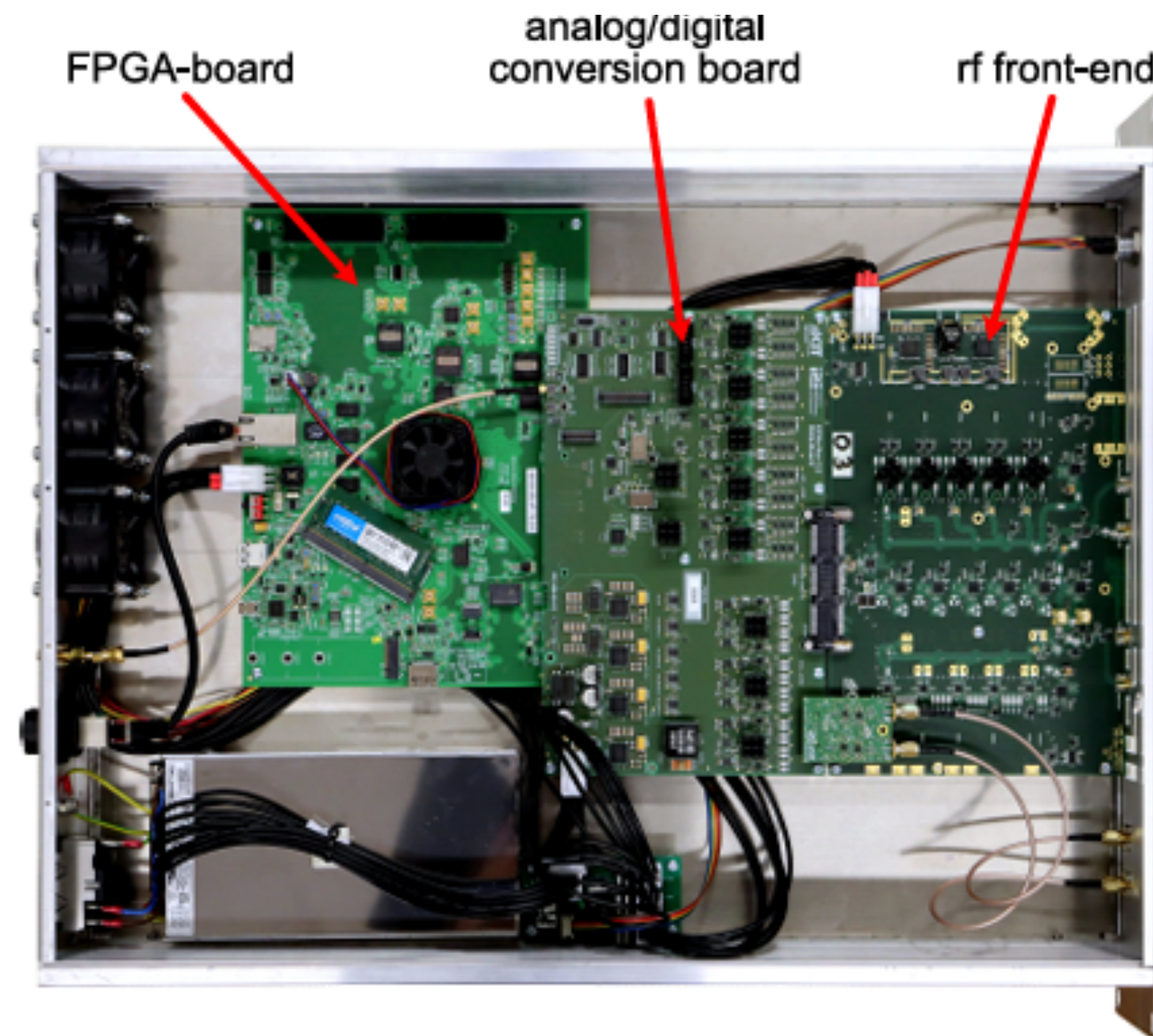

Courtesy of L. Gastaldo

ECHO-100k

Activity per pixel: 10 Bq
 Number of detectors: 12000
 Readout: microwave SQUID multiplexing

$$m(\nu_e) < 1.5 \text{ eV (90\% C.L.)}$$

R&D for detector optimization
 and multiplexing

Multiplexed readout: microwave SQUID multiplexing
 Single HEMT amplifier and 2 coaxes
 to read out 400 detectors

25 cryogenic readout lines for 20000 detectors

- Full-scale readout electronics system ready for production of 15 units (12000 detectors)
- Real-time digital signal processing firmware is ready

ECHO-LE (2026 - 2030)

Activity per pixel ~ 10 Bq/pixel
 Number of detectors: 20000 \rightarrow Multiplexed readout

$$\Delta E_{\text{FWHM}} < 5 \text{ eV}$$

$$f_{\text{pu}} < 10^{-6}$$

$$b < 10^{-6} / \text{eV/detector/day}$$

$$m_{\beta} < 0.8 \text{ eV}/c^2 \text{ (90\% C.L.)}$$

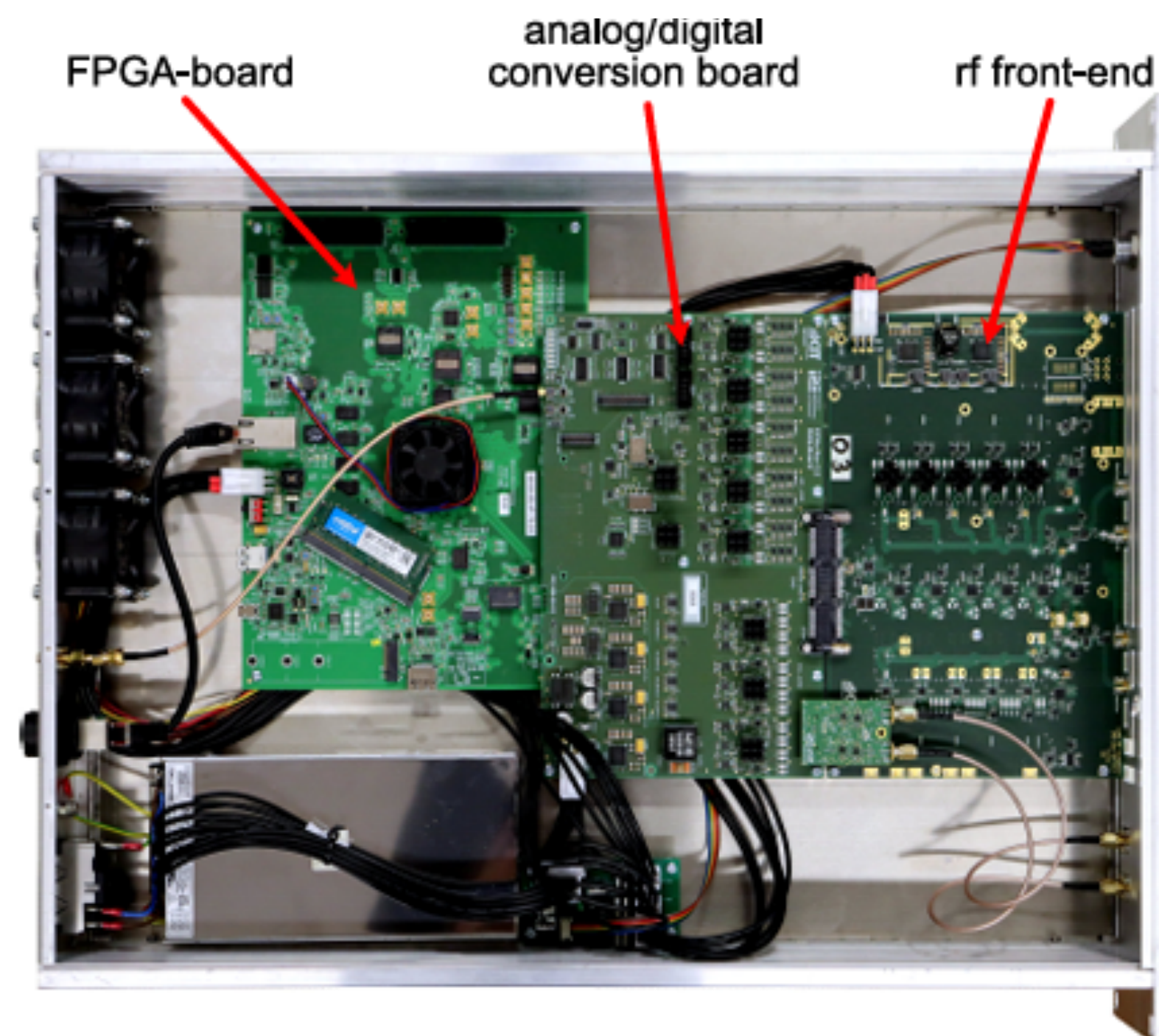

Improved chip design for higher
 fabrication yield
 Galvanization of second absorber layer

10 wafers * 40 chips * 60 pixels

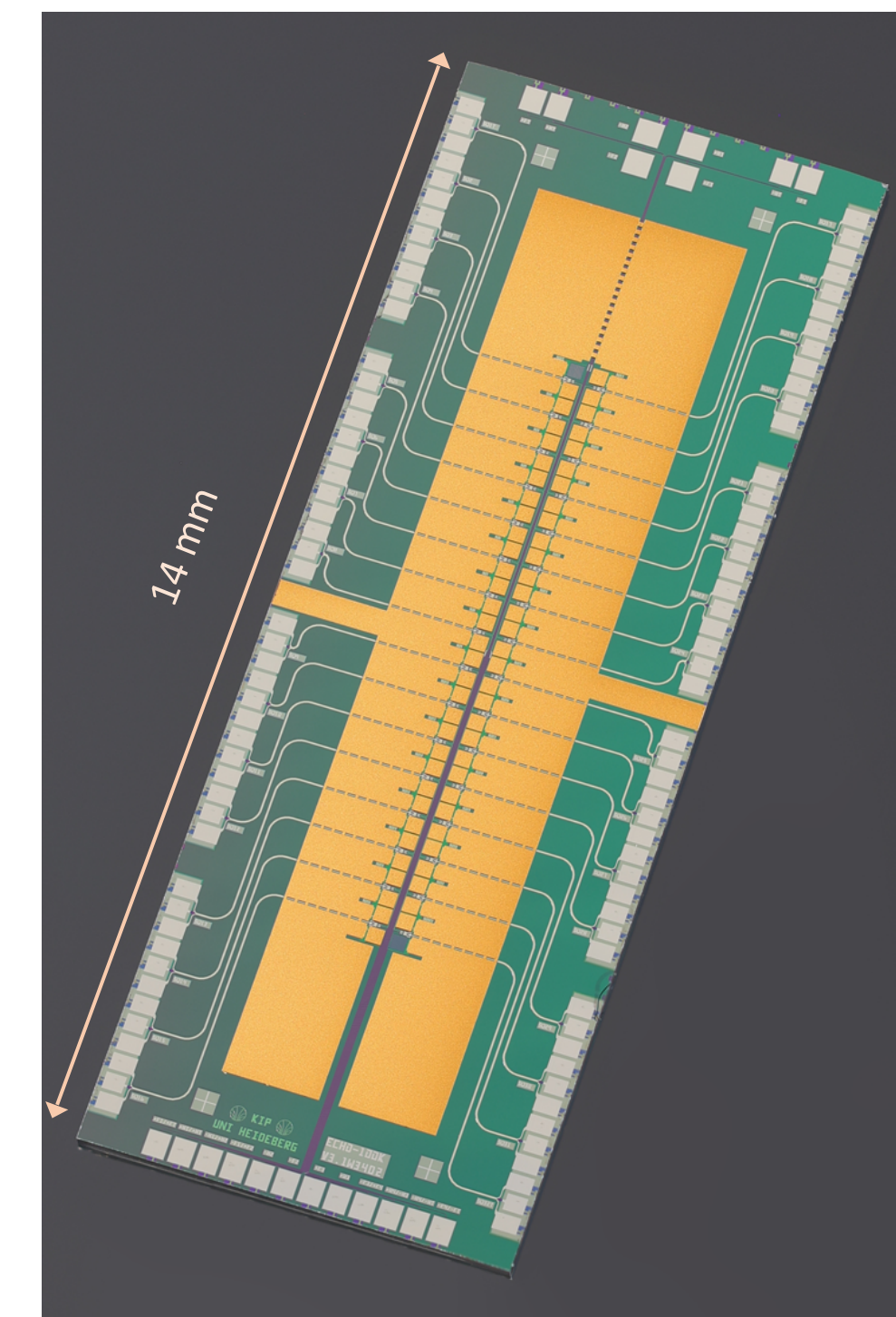

Courtesy of L. Gastaldo



Cyclotron Radiation Emission Spectroscopy (CRES)

- Place beta decay (of tritium) electron in uniform magnetic field

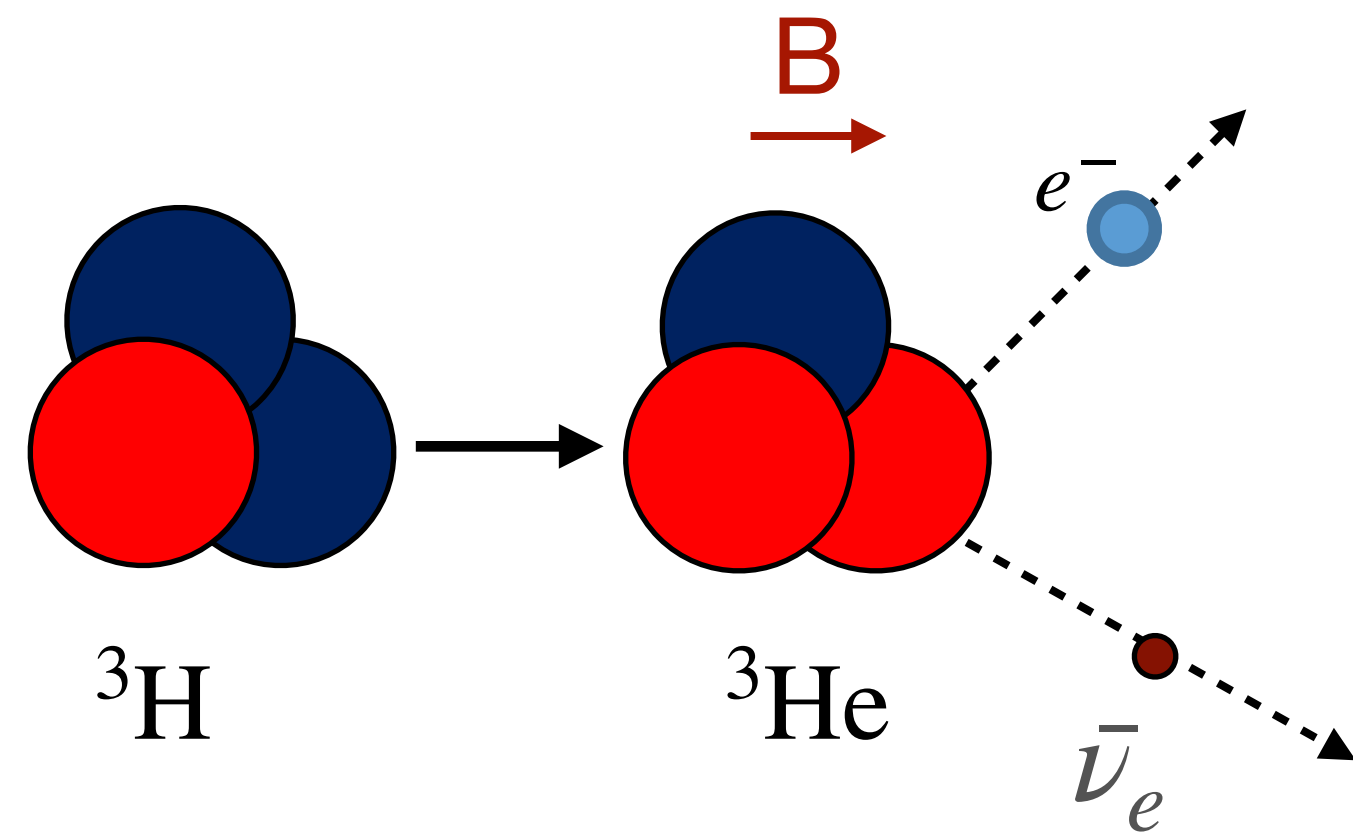



Cyclotron Radiation Emission Spectroscopy (CRES)

- Place beta decay (of tritium) electron in uniform magnetic field
- It undergoes cyclotron motion and emits cyclotron radiation

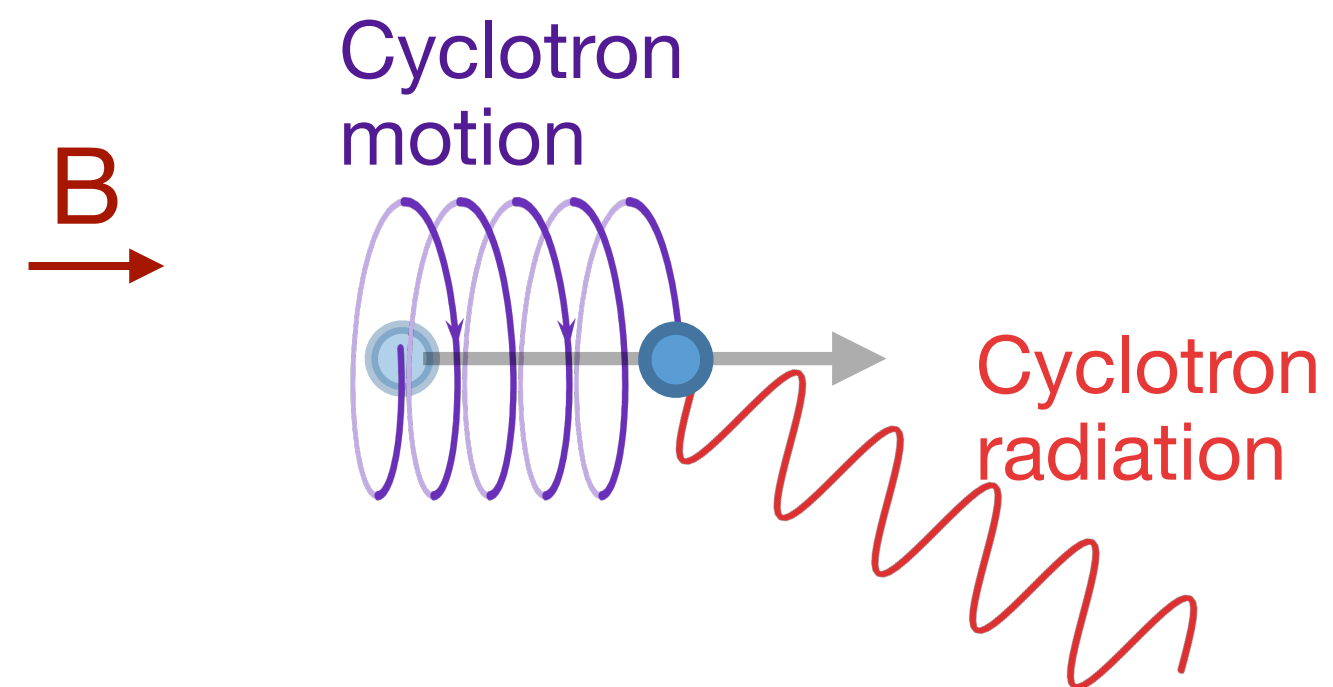



Cyclotron Radiation Emission Spectroscopy (CRES)

- Place beta decay (of tritium) electron in uniform magnetic field
- It undergoes cyclotron motion and emits cyclotron radiation
- Keep the electron for long enough time to measure the cyclotron frequency

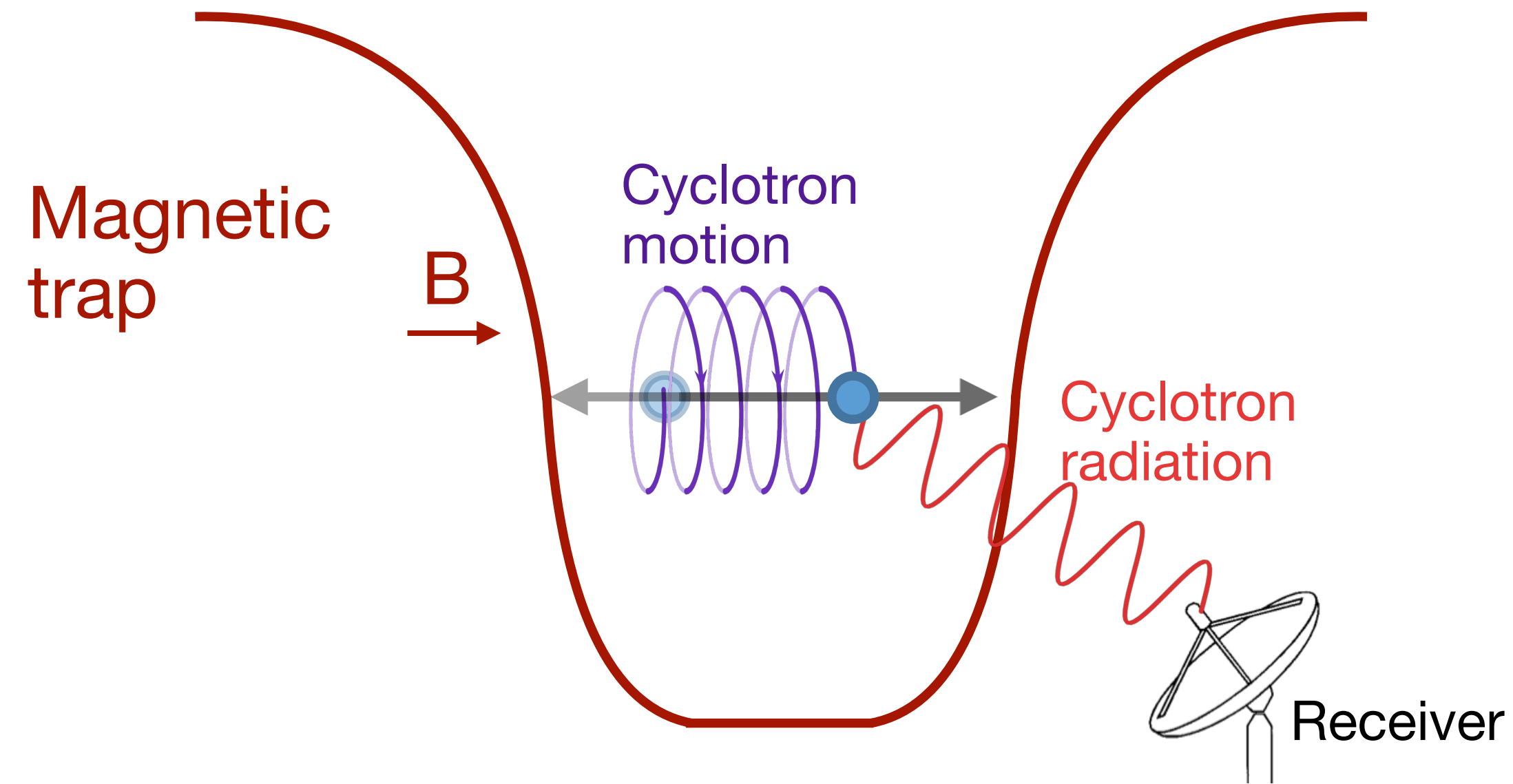



Cyclotron Radiation Emission Spectroscopy (CRES)

- Place beta decay (of tritium) electron in uniform magnetic field
- It undergoes cyclotron motion and emits cyclotron radiation
- Keep the electron for long enough time to measure the cyclotron frequency
- Cyclotron frequency has one-to-one relation with the electron kinetic energy
- Measure the kinetic energy of many such electrons to build a spectrum

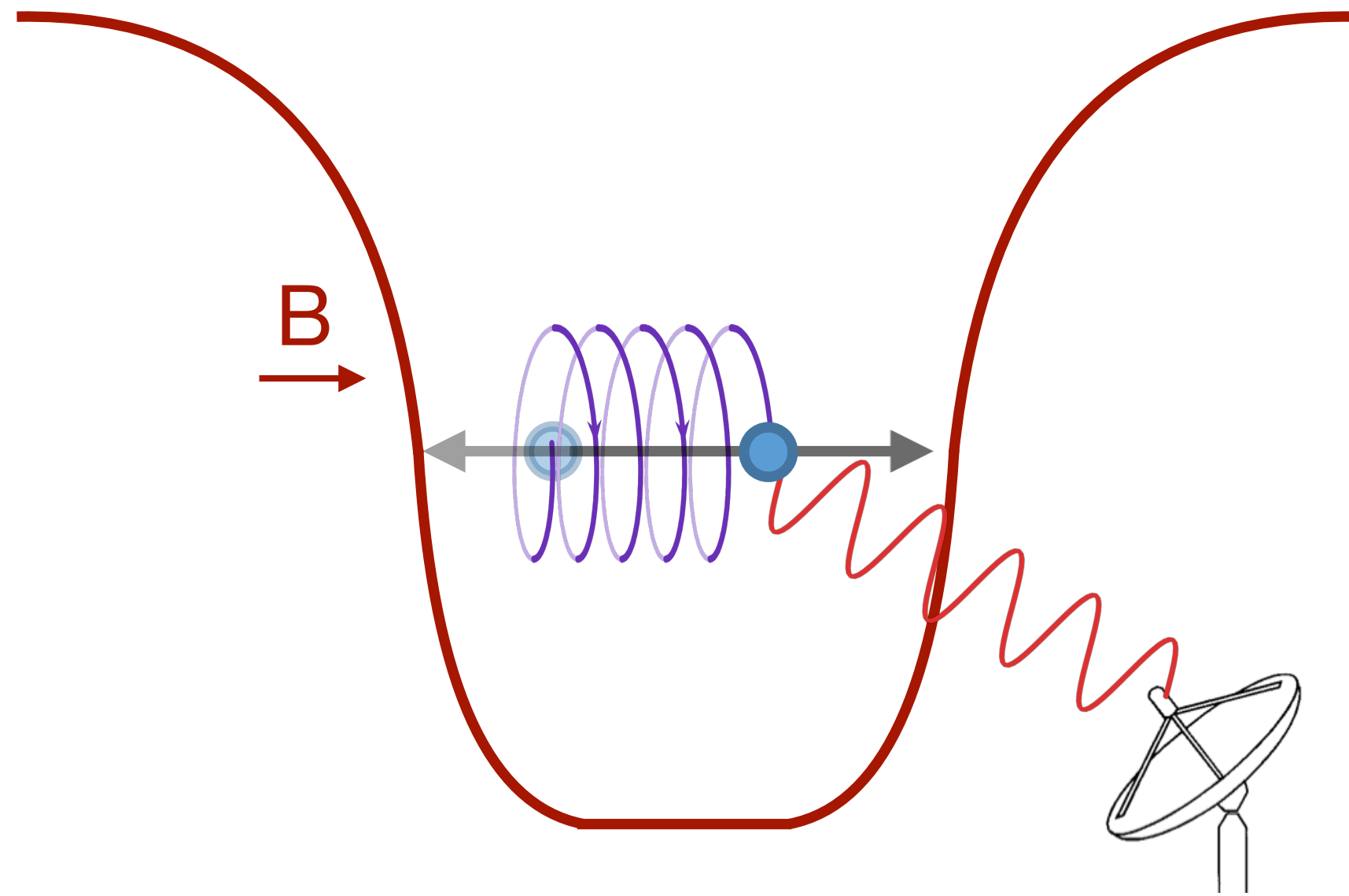

$$f_c = \frac{q\langle B \rangle}{2\pi(m_e + E_{\text{kin}})}$$

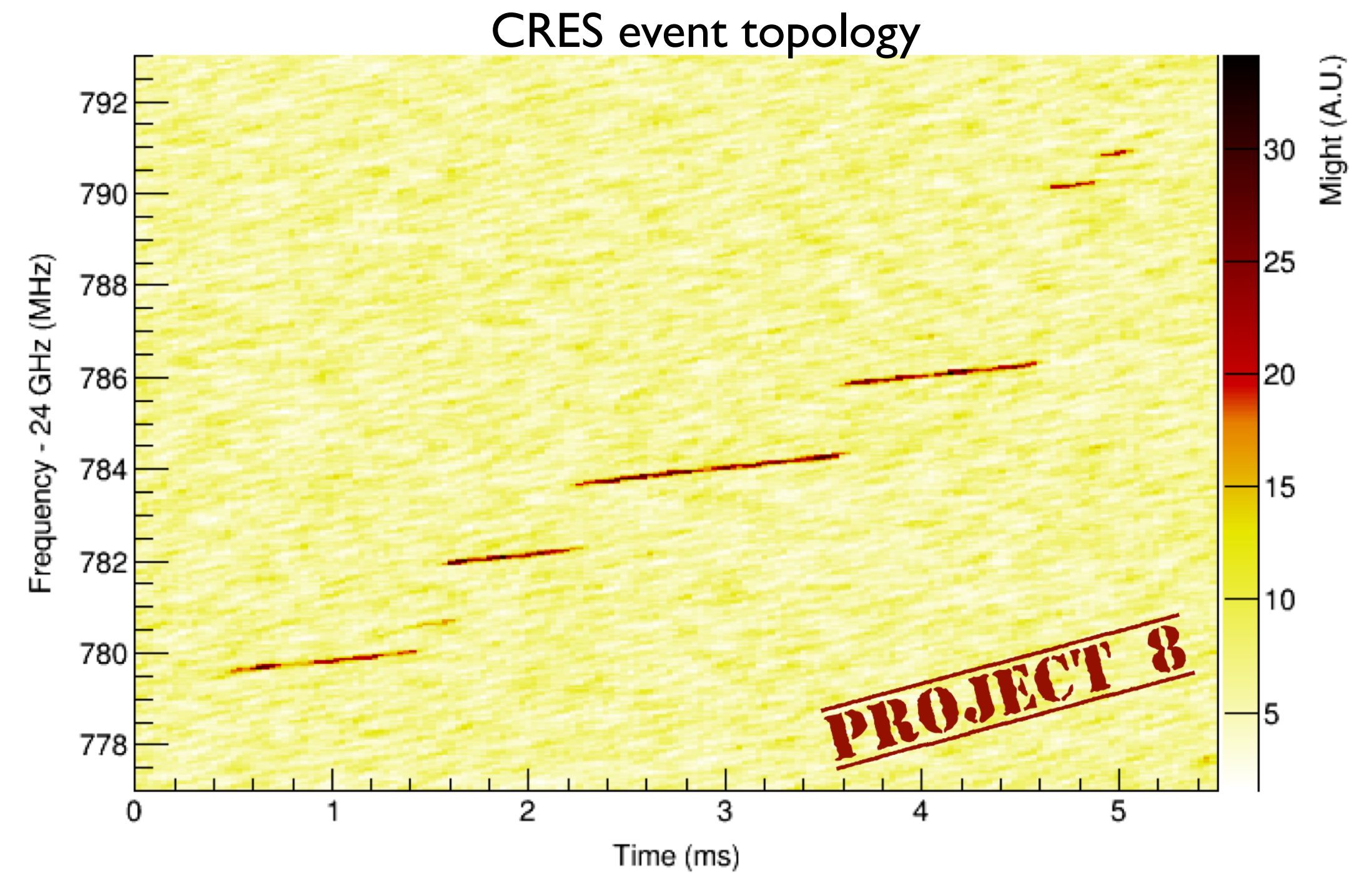



Cyclotron Radiation Emission Spectroscopy (CRES)

- Place beta decay (of tritium) electron in uniform magnetic field
- It undergoes cyclotron motion and emits cyclotron radiation
- Keep the electron for long enough time to measure the cyclotron frequency
- Cyclotron frequency has one-to-one relation with the electron kinetic energy
- Measure the kinetic energy of many such electrons to build a spectrum

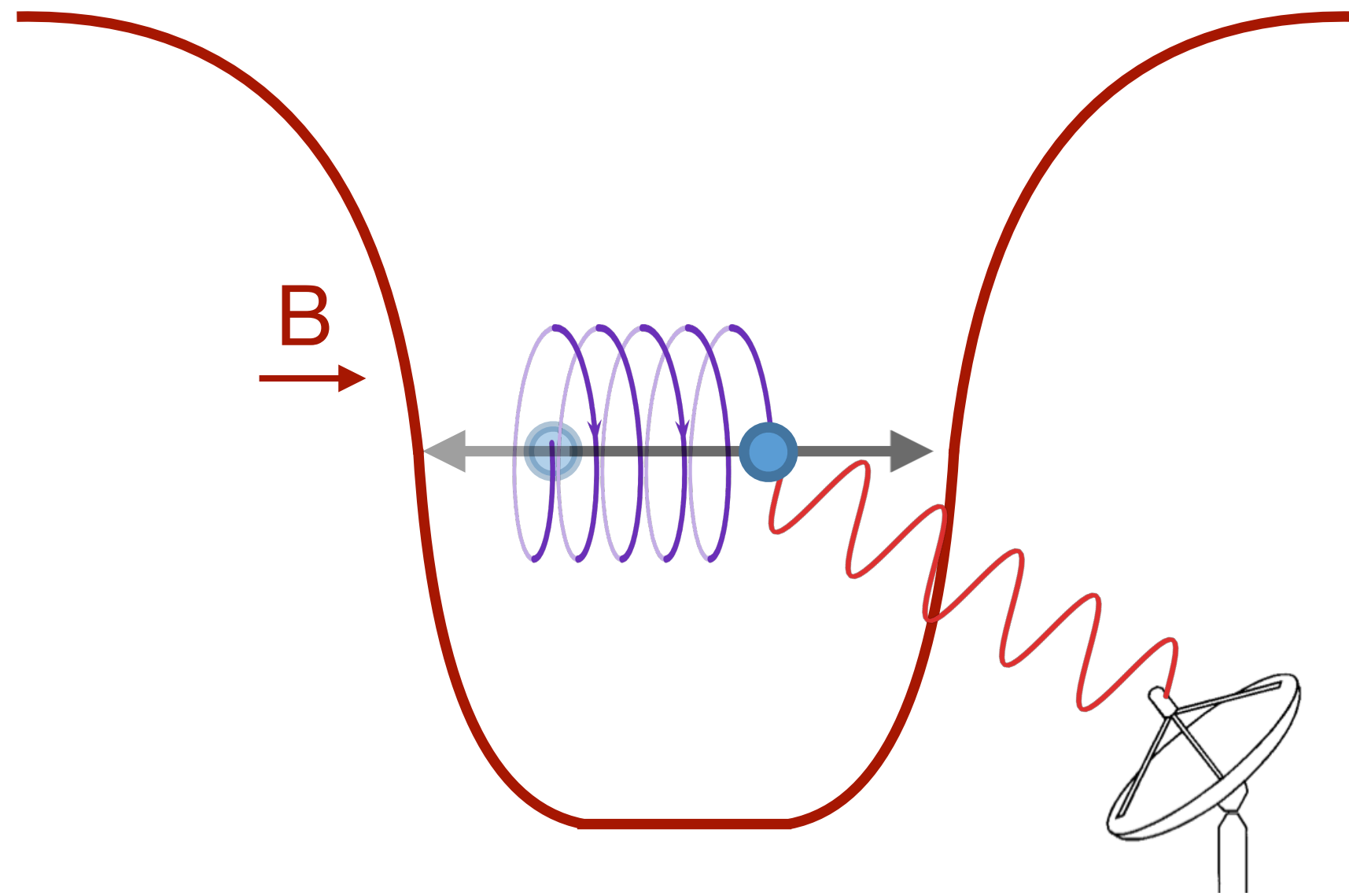

$$f_c = \frac{q\langle B \rangle}{2\pi(m_e + E_{\text{kin}})}$$

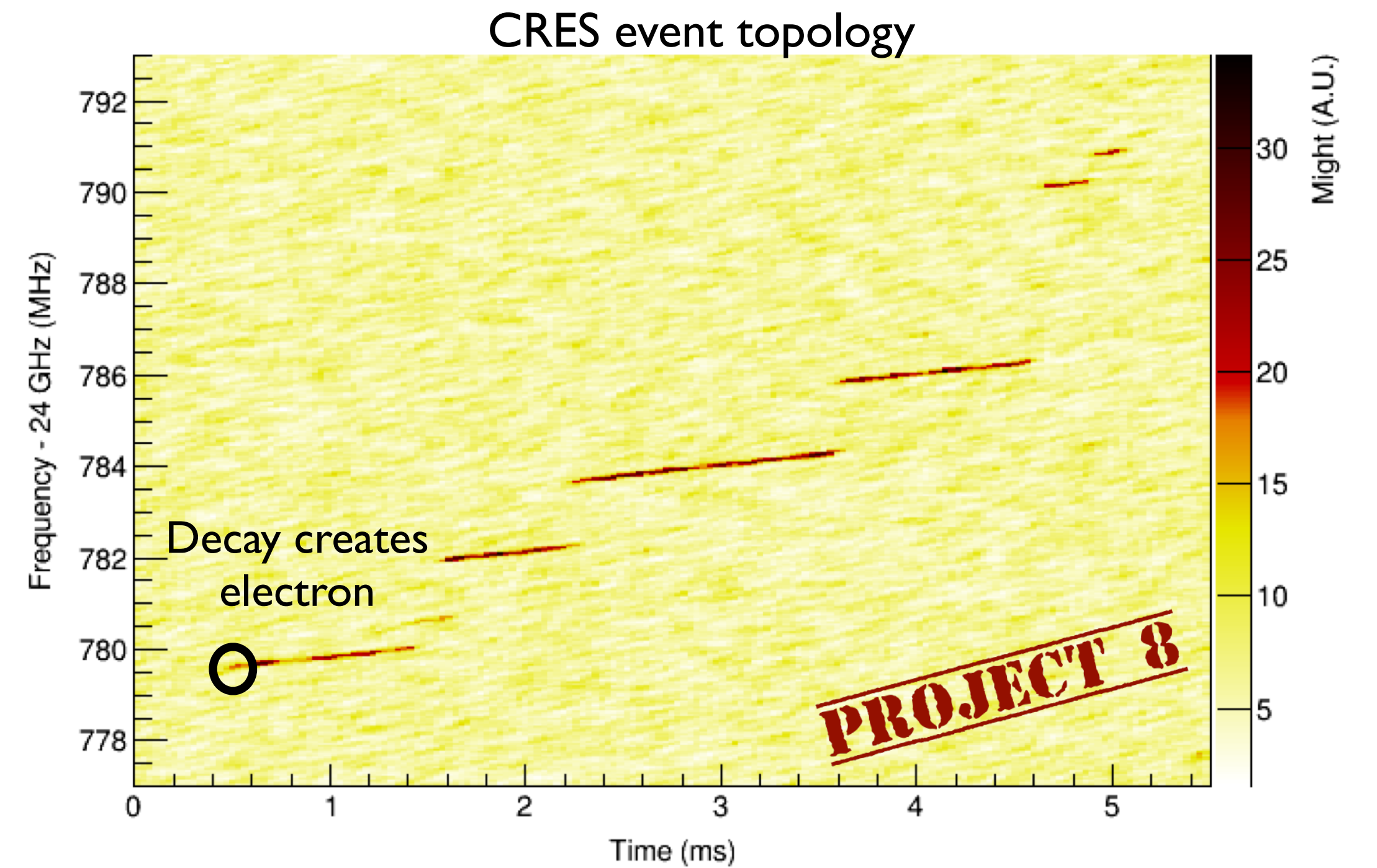



Cyclotron Radiation Emission Spectroscopy (CRES)

- Place beta decay (of tritium) electron in uniform magnetic field
- It undergoes cyclotron motion and emits cyclotron radiation
- Keep the electron for long enough time to measure the cyclotron frequency
- Cyclotron frequency has one-to-one relation with the electron kinetic energy
- Measure the kinetic energy of many such electrons to build a spectrum

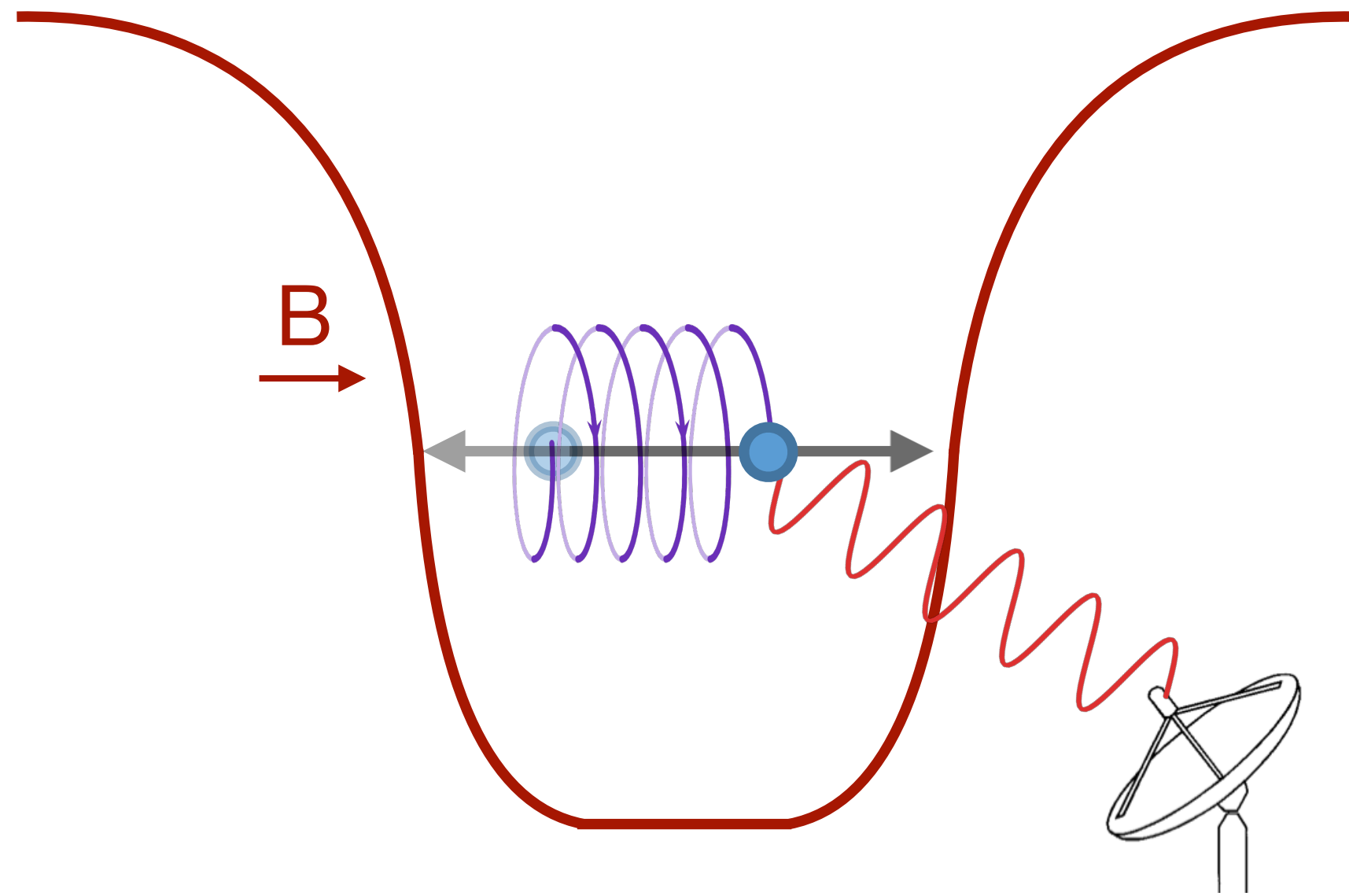

$$f_c = \frac{q\langle B \rangle}{2\pi(m_e + E_{\text{kin}})}$$

CRES event topology

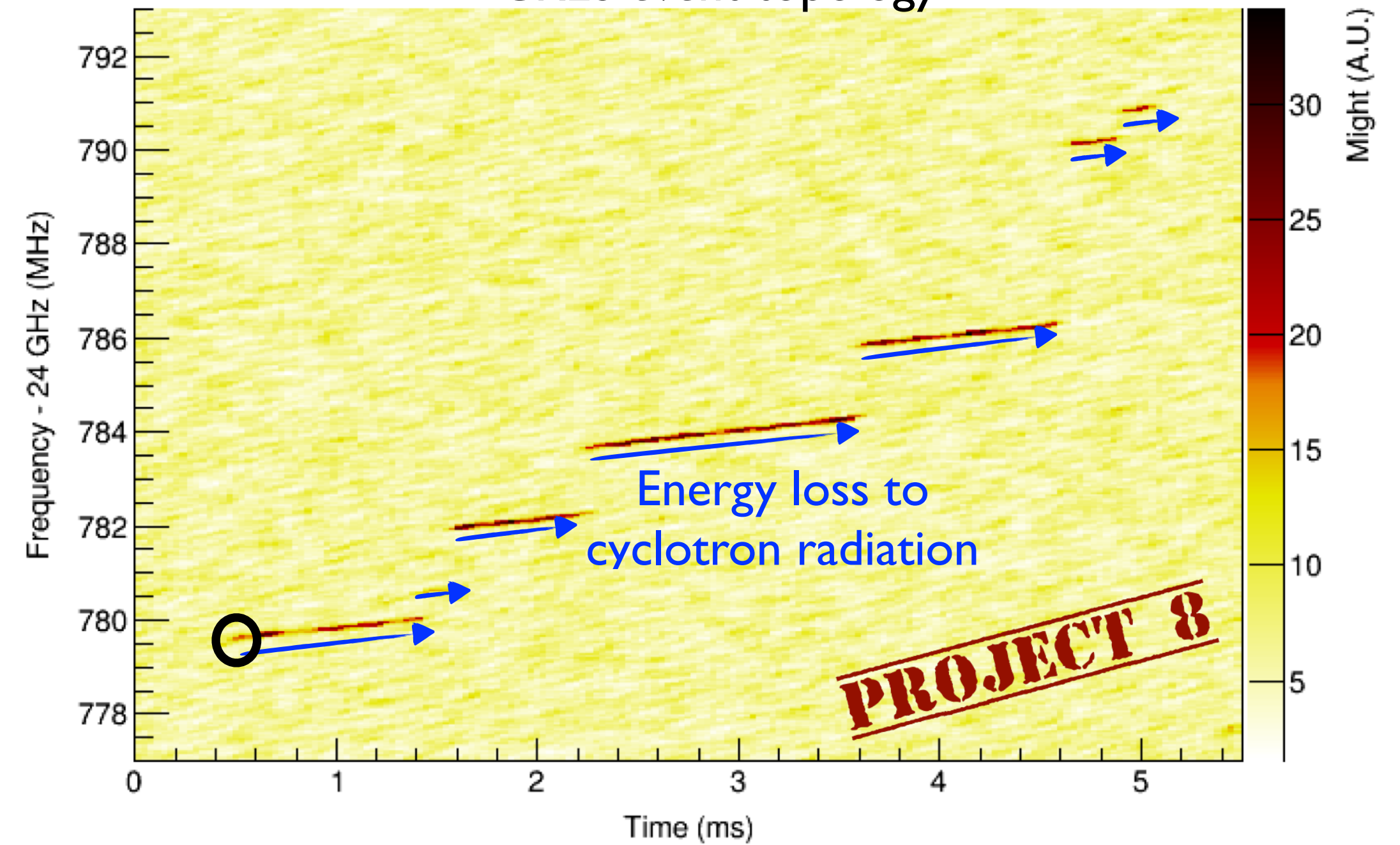



Cyclotron Radiation Emission Spectroscopy (CRES)

- Place beta decay (of tritium) electron in uniform magnetic field
- It undergoes cyclotron motion and emits cyclotron radiation
- Keep the electron for long enough time to measure the cyclotron frequency
- Cyclotron frequency has one-to-one relation with the electron kinetic energy
- Measure the kinetic energy of many such electrons to build a spectrum

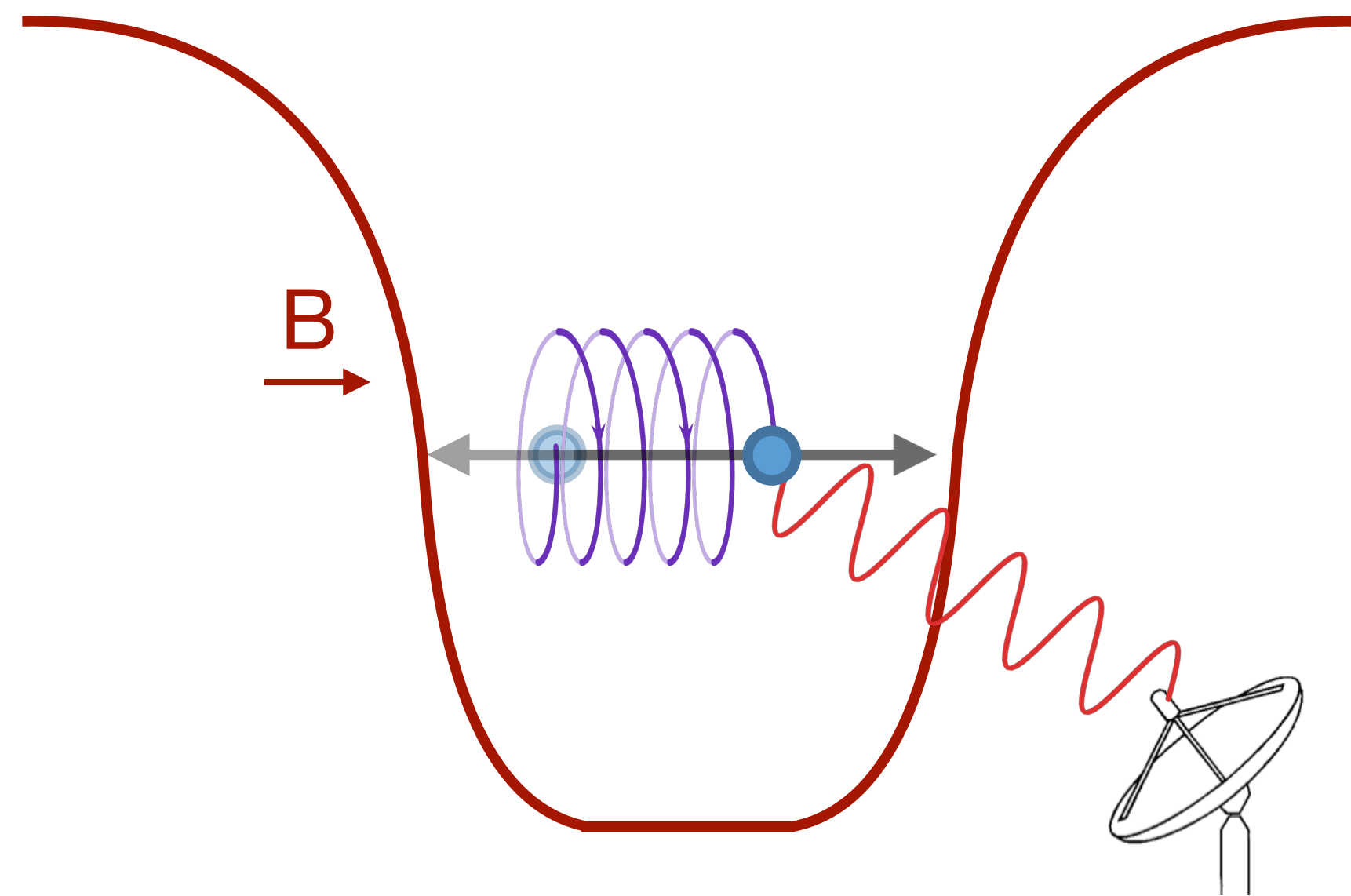

$$f_c = \frac{q\langle B \rangle}{2\pi(m_e + E_{\text{kin}})}$$

CRES event topology

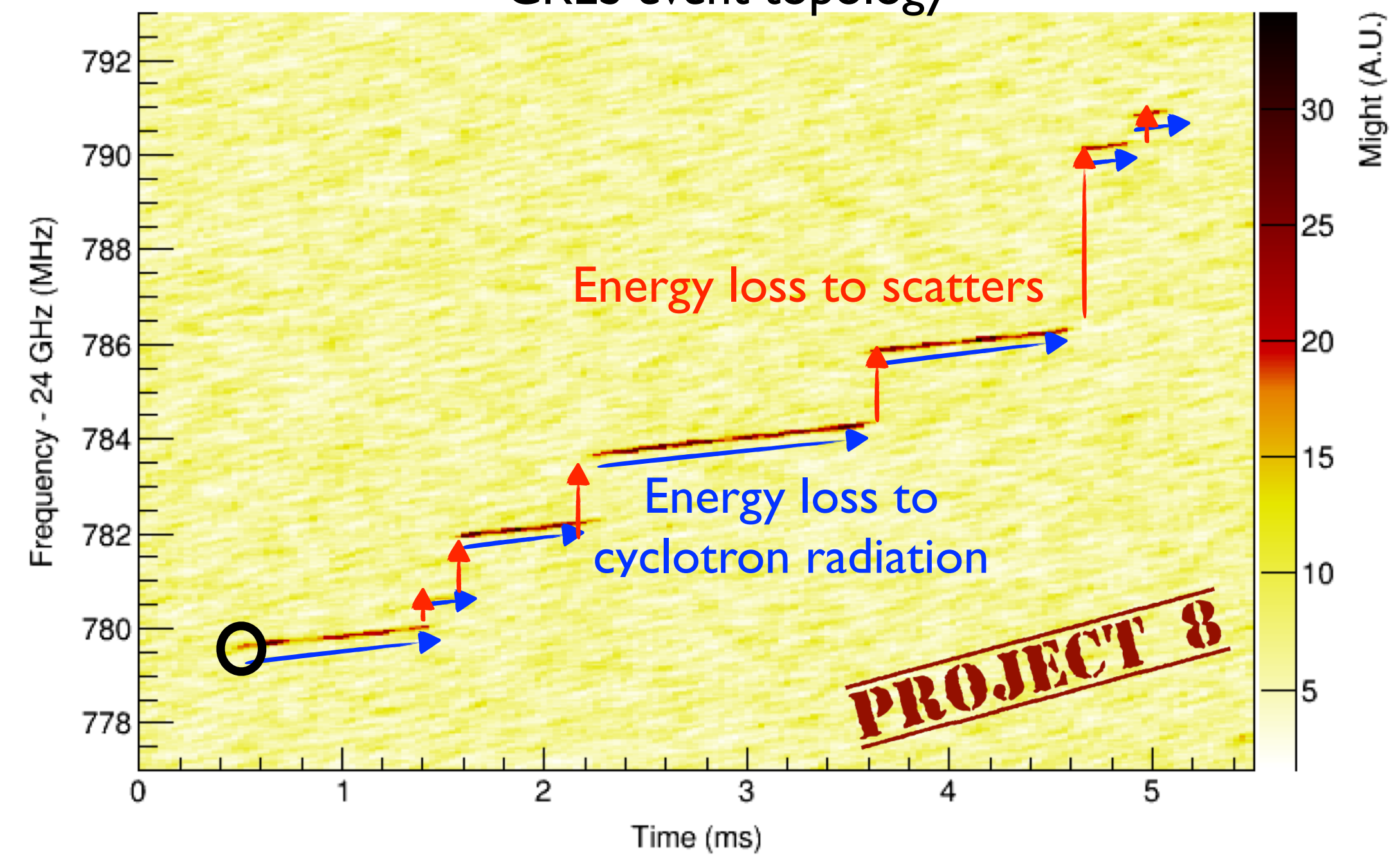



Cyclotron Radiation Emission Spectroscopy (CRES)

- Place beta decay (of tritium) electron in uniform magnetic field
- It undergoes cyclotron motion and emits cyclotron radiation
- Keep the electron for long enough time to measure the cyclotron frequency
- Cyclotron frequency has one-to-one relation with the electron kinetic energy
- Measure the kinetic energy of many such electrons to build a spectrum

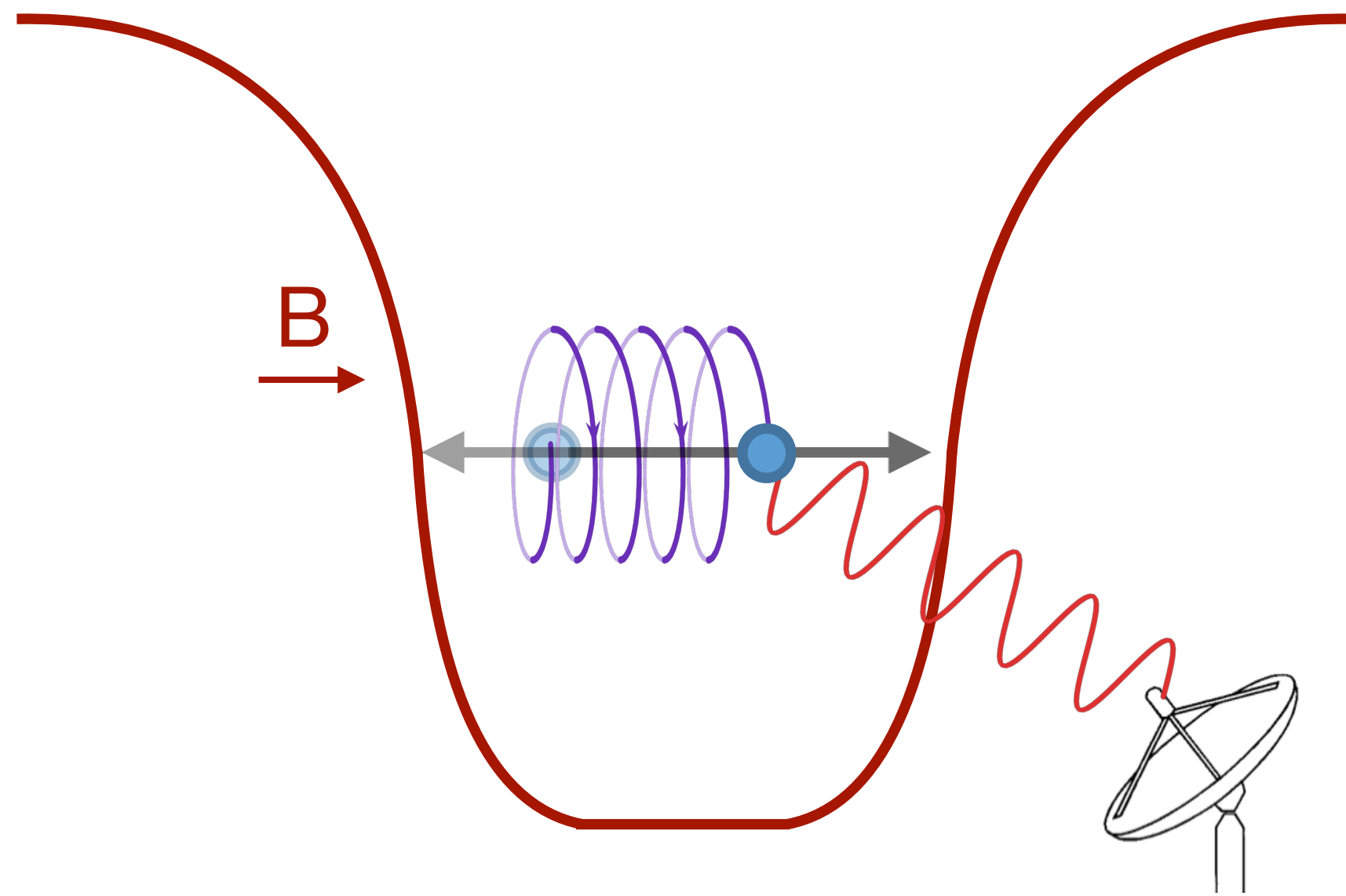

$$f_c = \frac{q\langle B \rangle}{2\pi(m_e + E_{\text{kin}})}$$

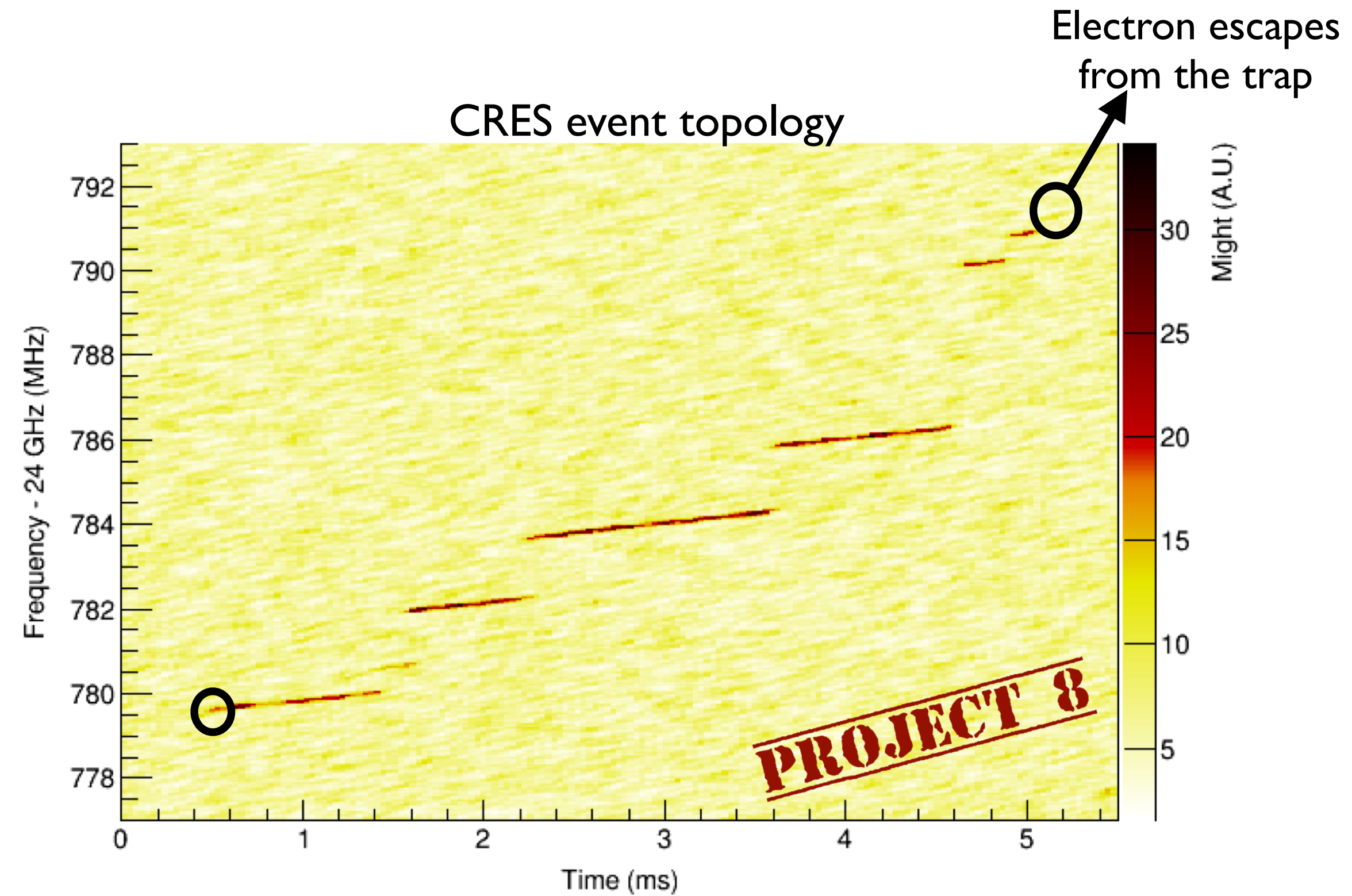



Cyclotron Radiation Emission Spectroscopy (CRES)

- Place beta decay (of tritium) electron in uniform magnetic field
- It undergoes cyclotron motion and emits cyclotron radiation
- Keep the electron for long enough time to measure the cyclotron frequency
- Cyclotron frequency has one-to-one relation with the electron kinetic energy
- Measure the kinetic energy of many such electrons to build a spectrum

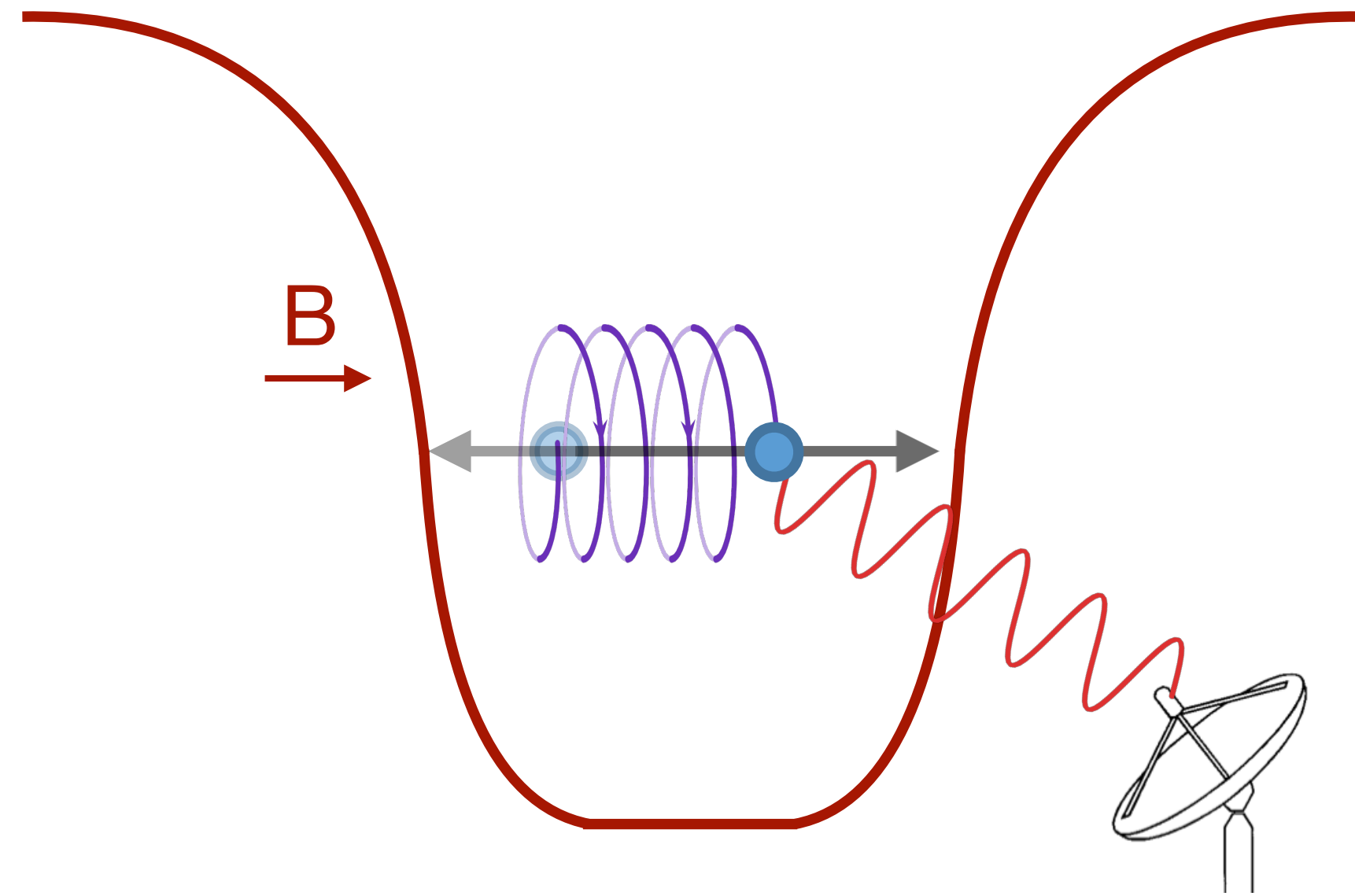

$$f_c = \frac{q\langle B \rangle}{2\pi(m_e + E_{\text{kin}})}$$

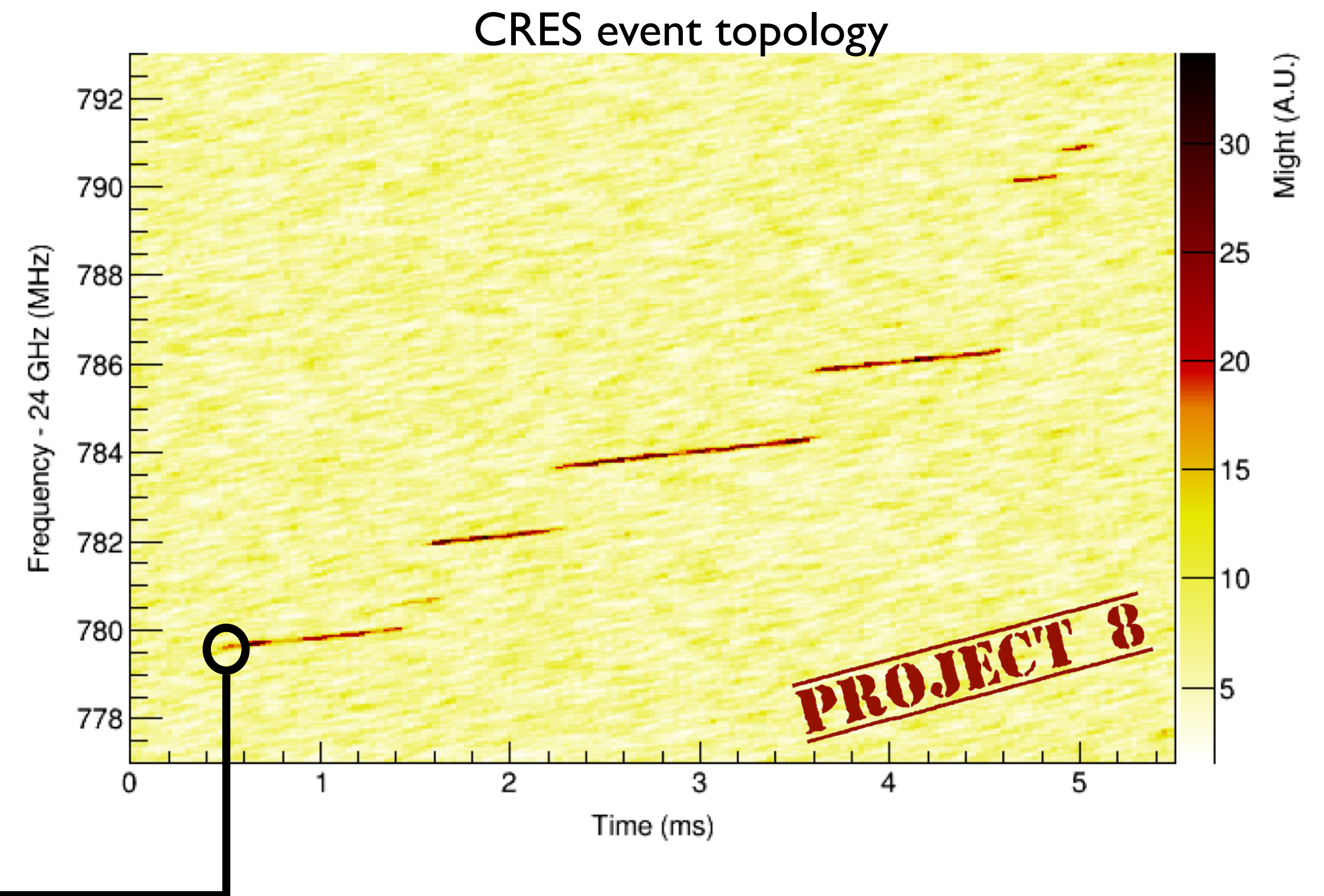



Cyclotron Radiation Emission Spectroscopy (CRES)

- Place beta decay (of tritium) electron in uniform magnetic field
- It undergoes cyclotron motion and emits cyclotron radiation
- Keep the electron for long enough time to measure the cyclotron frequency
- Cyclotron frequency has one-to-one relation with the electron kinetic energy
- Measure the kinetic energy of many such electrons to build a spectrum

- Source = detection volume => no transportation of tritium
- Differential spectrum measurement
- Enables large amount of atomic tritium
- Superior resolution and low background

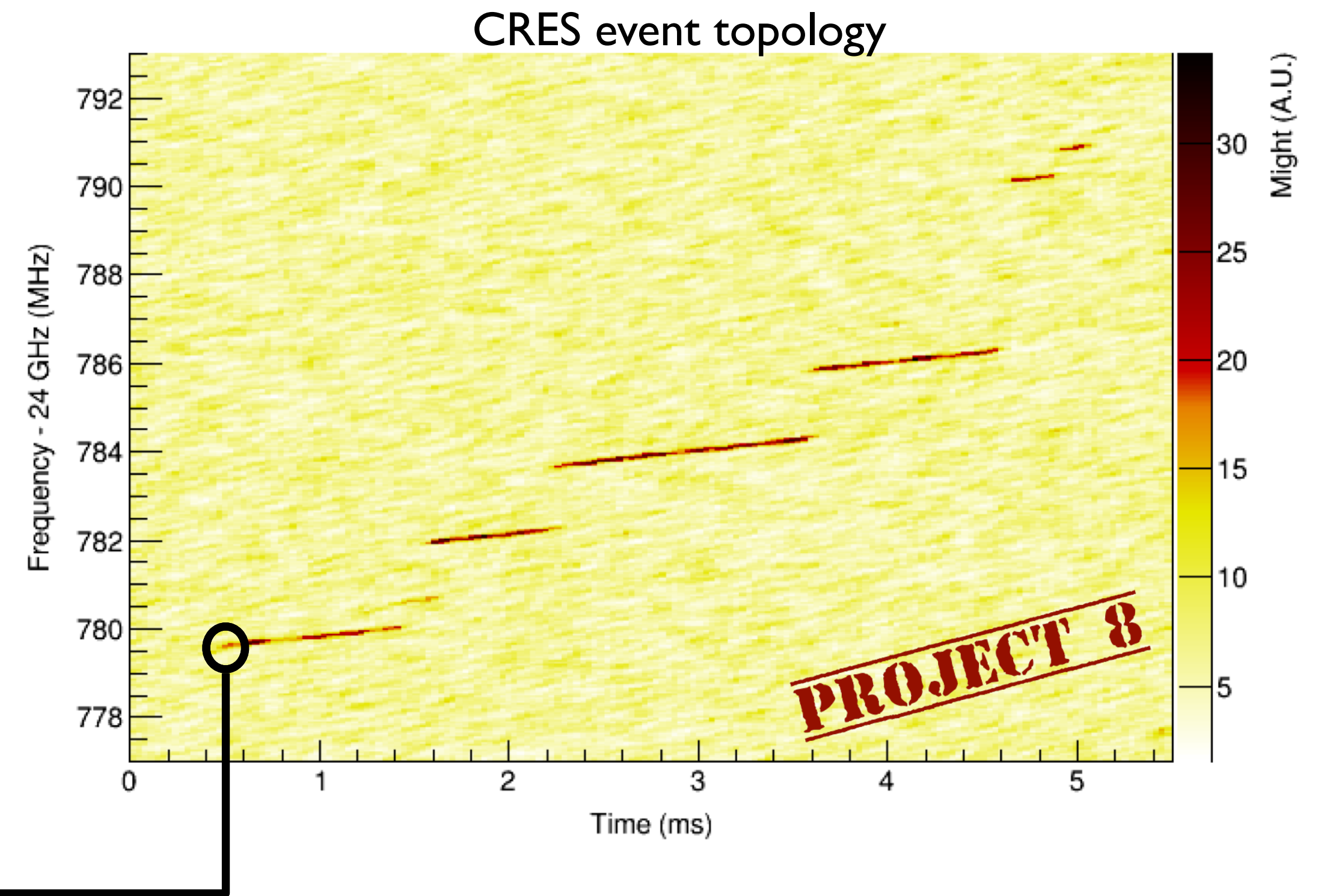
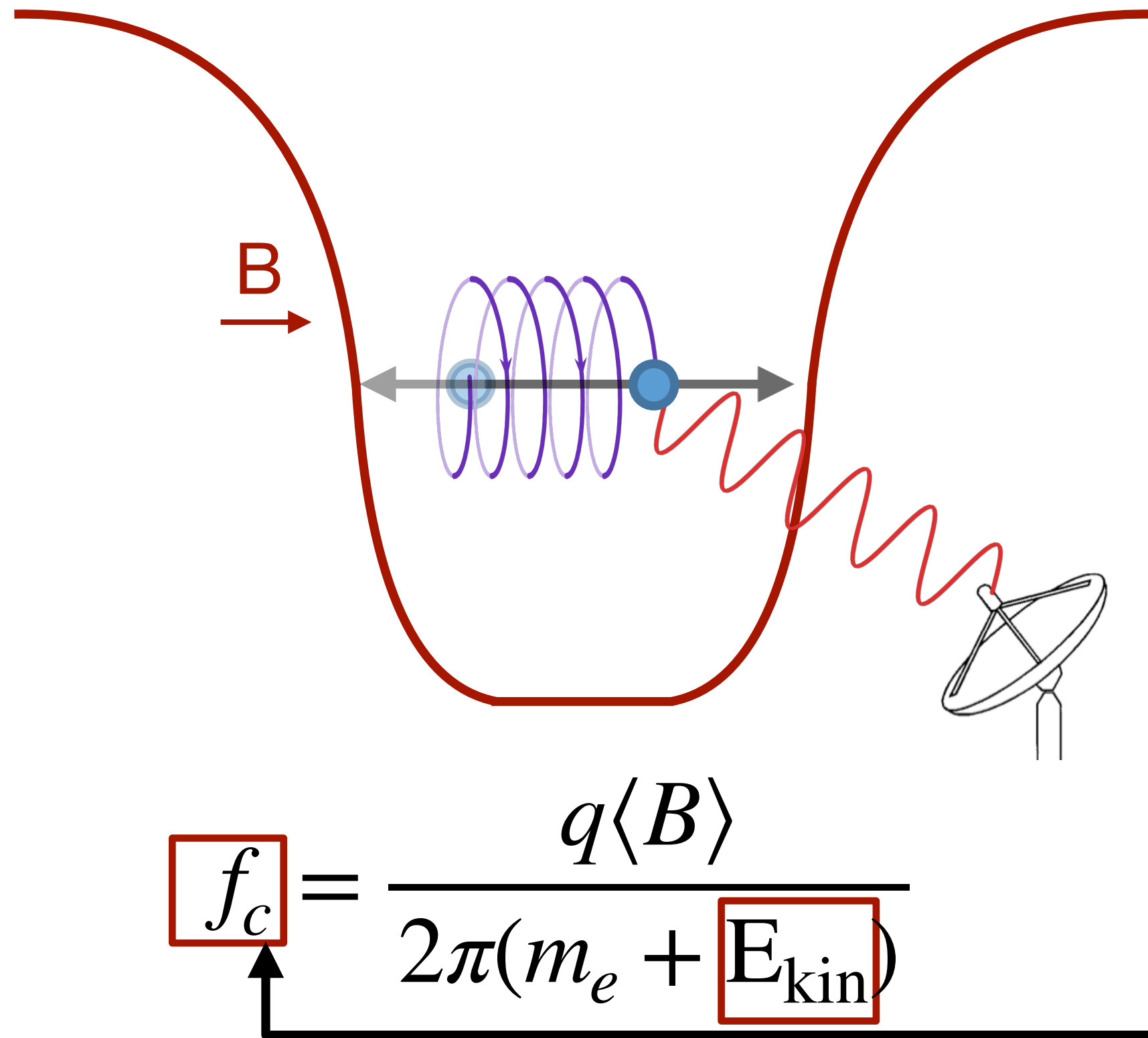



Cyclotron Radiation Emission Spectroscopy (CRES)

- Place beta decay (of tritium) electron in uniform magnetic field
- It undergoes cyclotron motion and emits cyclotron radiation
- Keep the electron for long enough time to measure the cyclotron frequency
- Cyclotron frequency has one-to-one relation with the electron kinetic energy
- Measure the kinetic energy of many such electrons to build a spectrum

- Source = detection volume => no transportation of tritium
- Differential spectrum measurement
- Enables large amount of atomic tritium
- Superior resolution and low background
- Detect and precisely reconstruct faint radiation (\sim aW—fW)

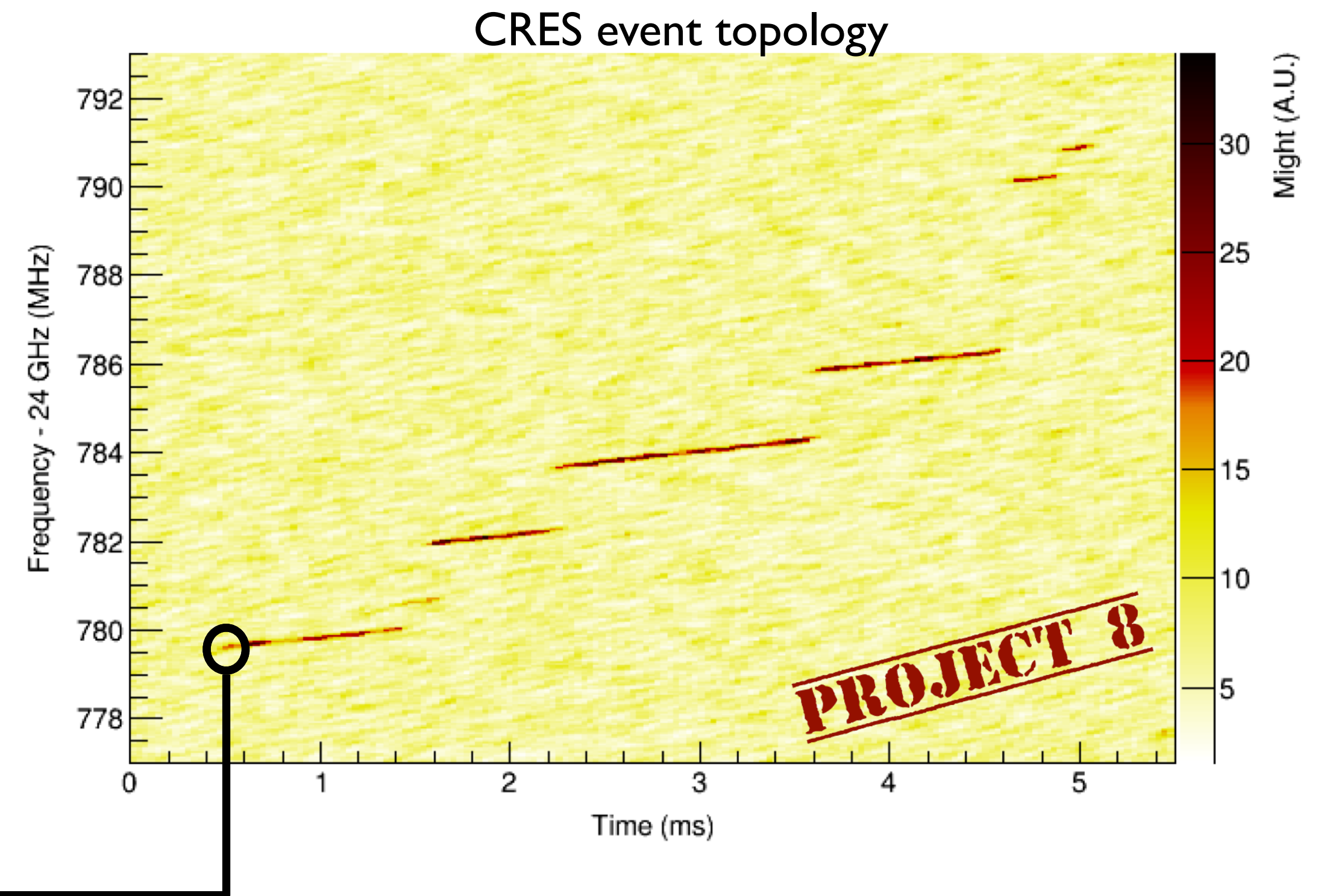
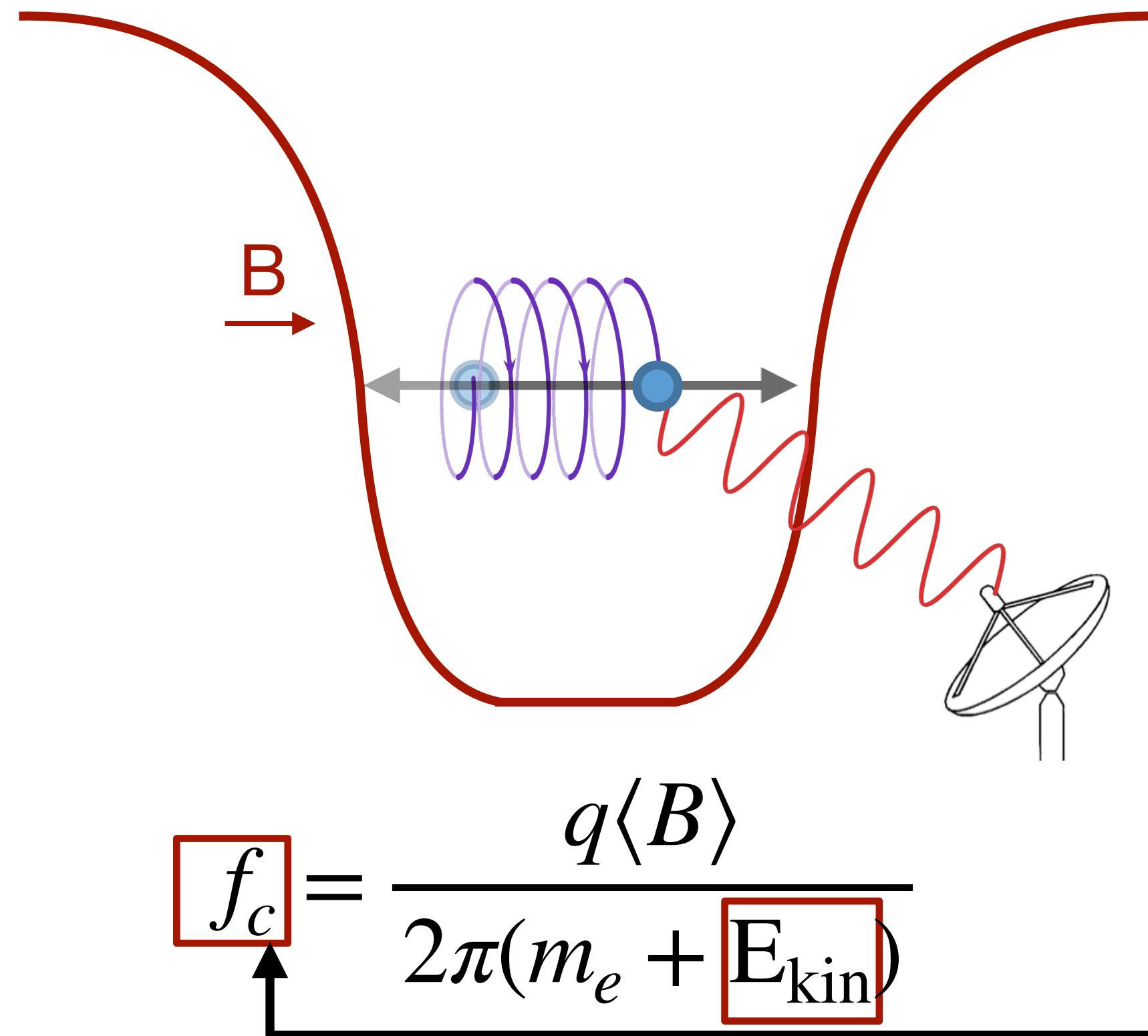



Part of **Q**uantum **T**echnologies for **F**undamental **P**hysics programme in the UK

- Addressing key challenges of CRES technology

Courtesy of R. Saakyan



Part of **Q**uantum **T**echnologies for **F**undamental **P**hysics programme in the UK

- Addressing key challenges of CRES technology

Observe $O(10^{19})$ T-atoms x yr(s)

- Cryogenic **supersonic atomic T** source
- Magnetic confinement in a **storage ring**
- Multiple CRES modules

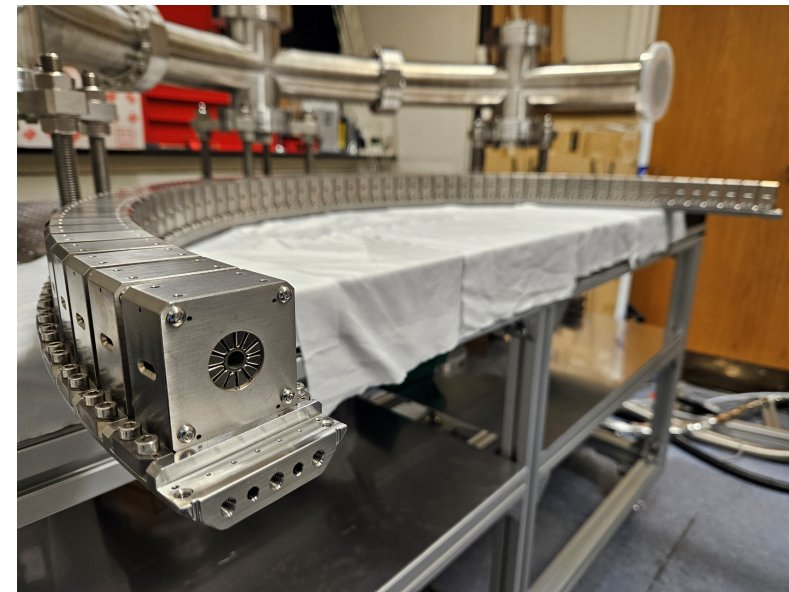
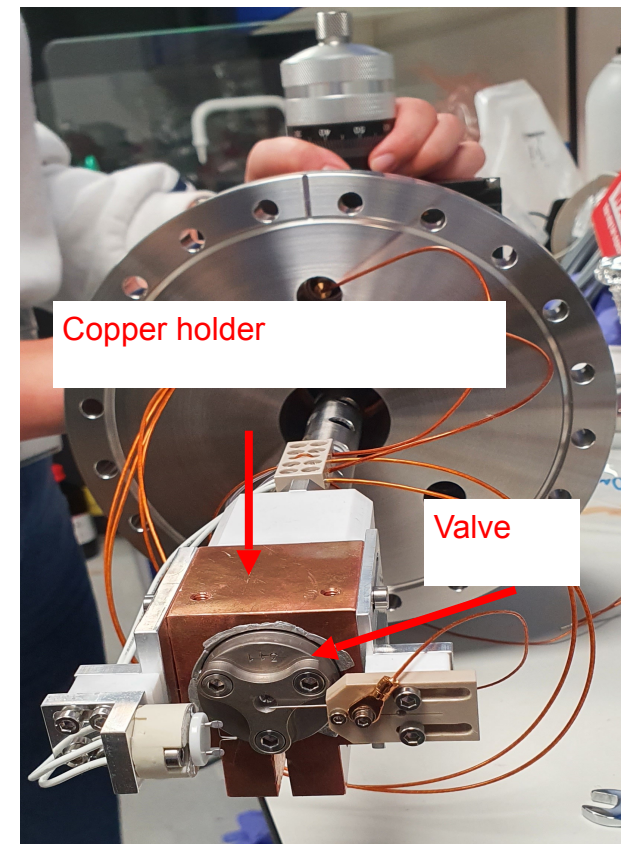

[A A S Amad et al 2025 New J. Phys. 27 105006](#)

Courtesy of R. Saakyan

Part of **Q**uantum **T**echnologies for **F**undamental **P**hysics programme in the UK

- Addressing key challenges of CRES technology

Observe $O(10^{19})$ T-atoms x yr(s)

- Cryogenic **supersonic atomic T** source
- Magnetic confinement in a **storage ring**
- Multiple CRES modules

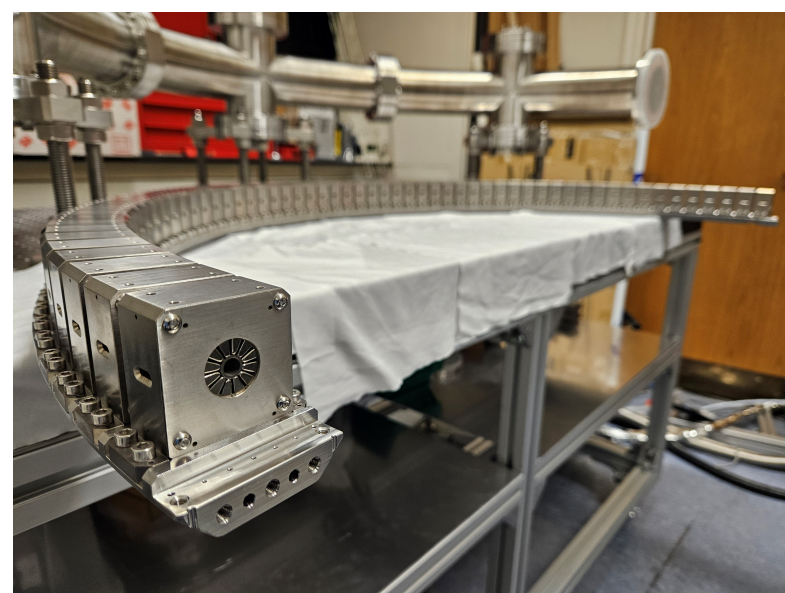
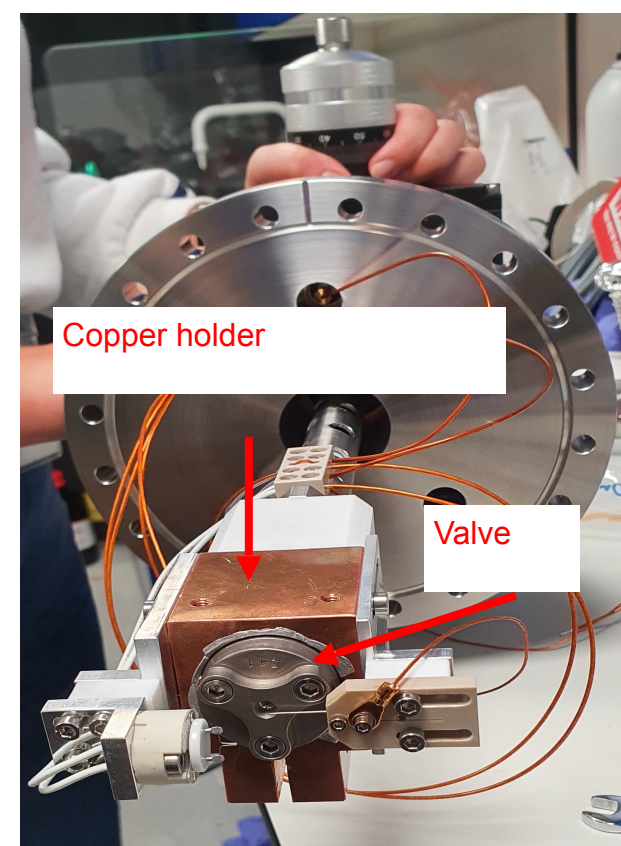

AA S Amad et al 2025 New J. Phys. 27 105006

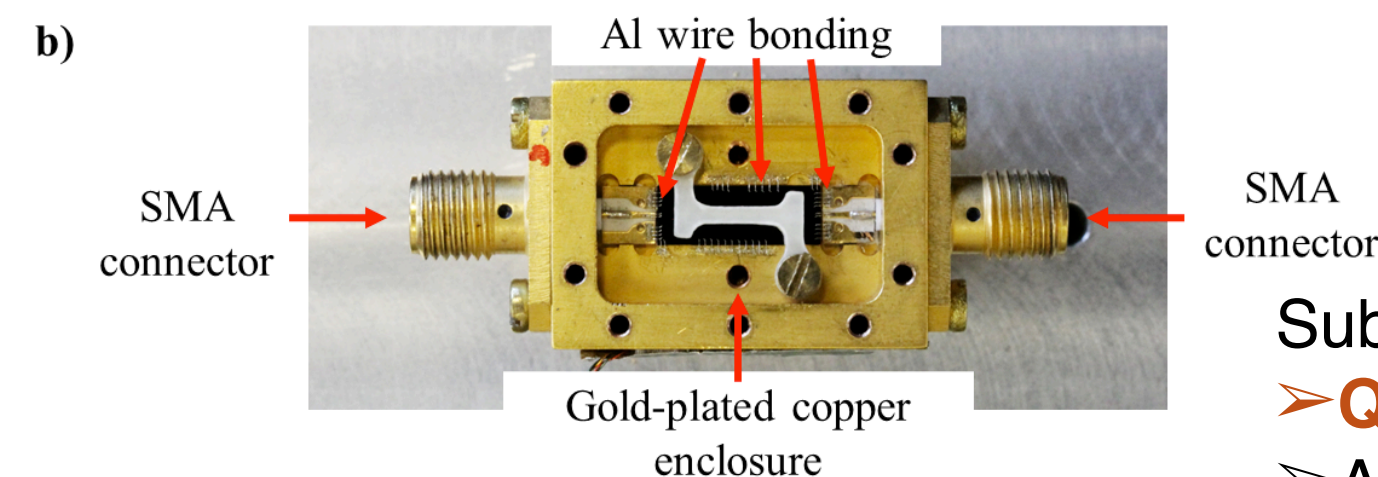
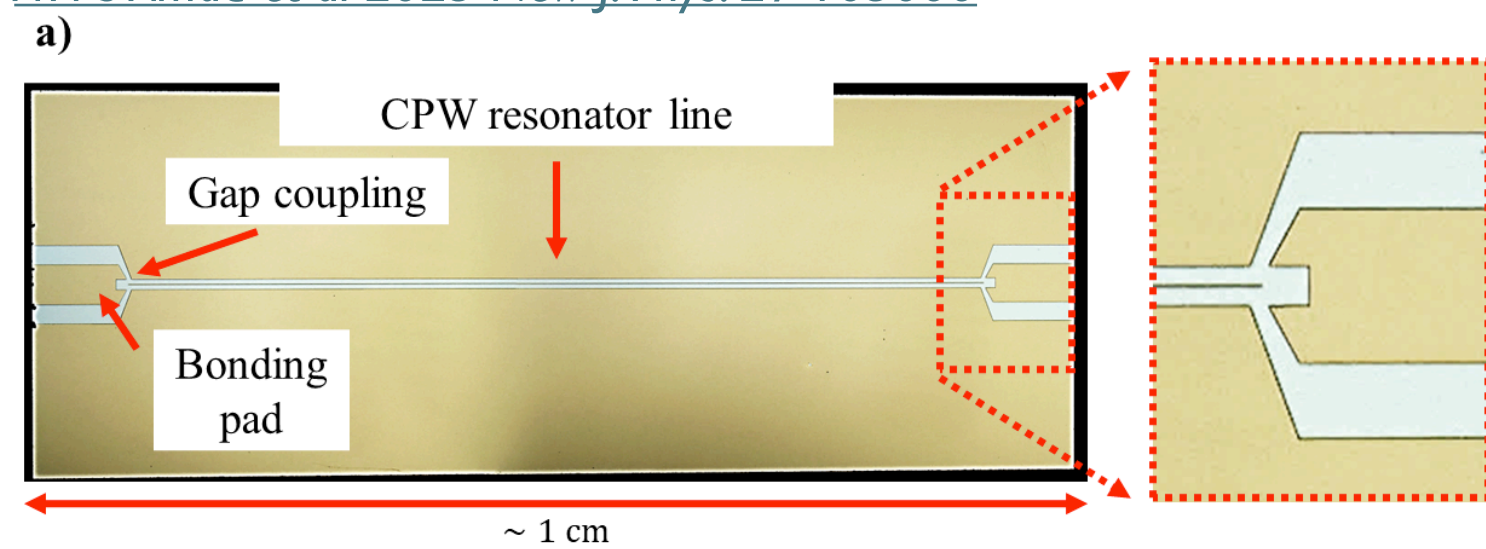

Sub-fw radiated powers, field of view, short observation time

- **Quantum-noise limited** superconducting microwave receivers
- Advanced triggering

Zhao et al., SC Sci.Tech. 36 (2023) 105010

Courtesy of R. Saakyan

Part of **Q**uantum **T**echnologies for **F**undamental **P**hysics programme in the UK

- Addressing key challenges of CRES technology

Observe $O(10^{19})$ T-atoms x yr(s)

- Cryogenic **supersonic atomic T** source
- Magnetic confinement in a **storage ring**
- Multiple CRES modules

Precision *in situ* determination of B- and E-fields

- 3D field mapping with **Rydberg** atoms as **quantum sensors**

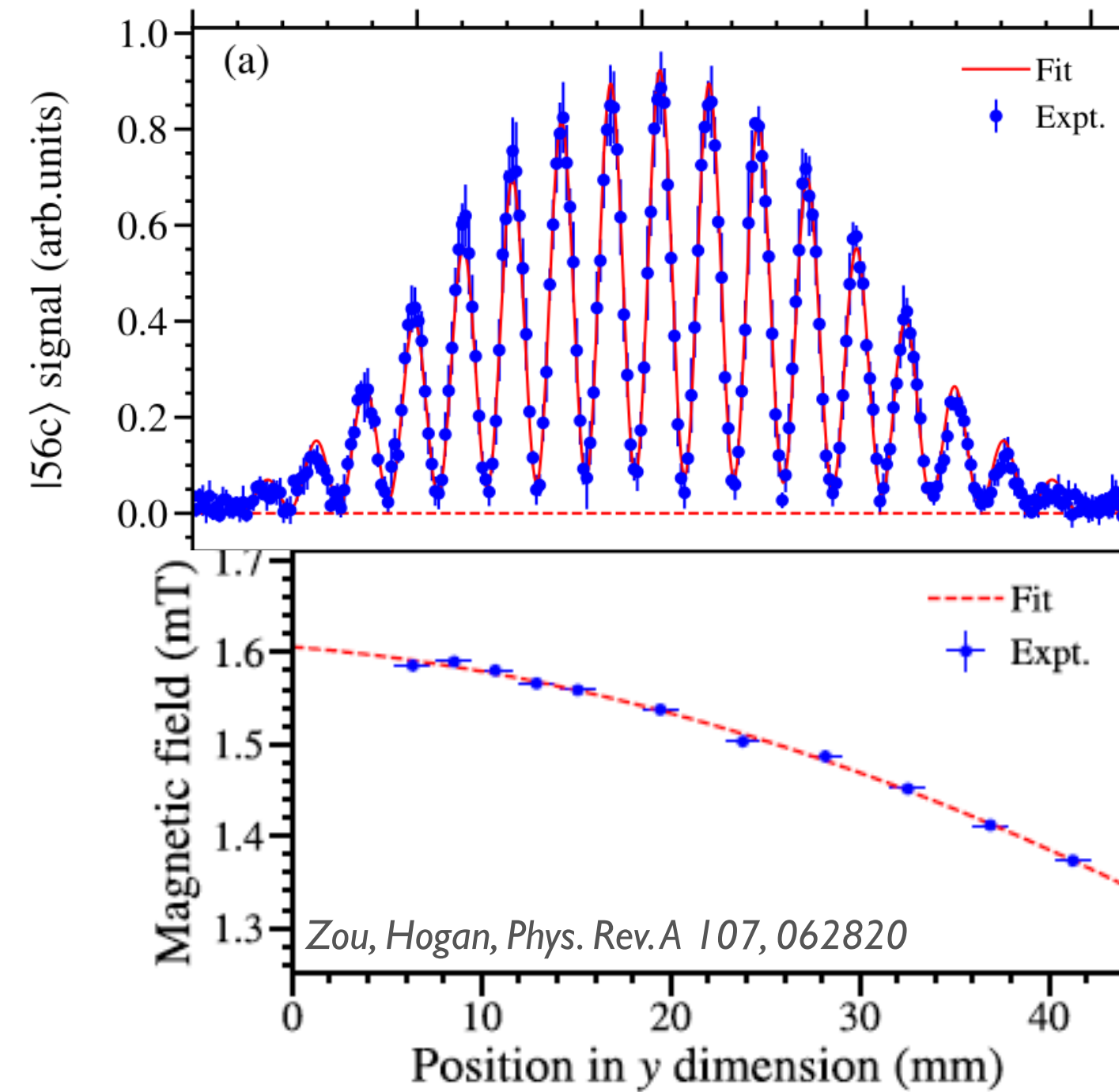
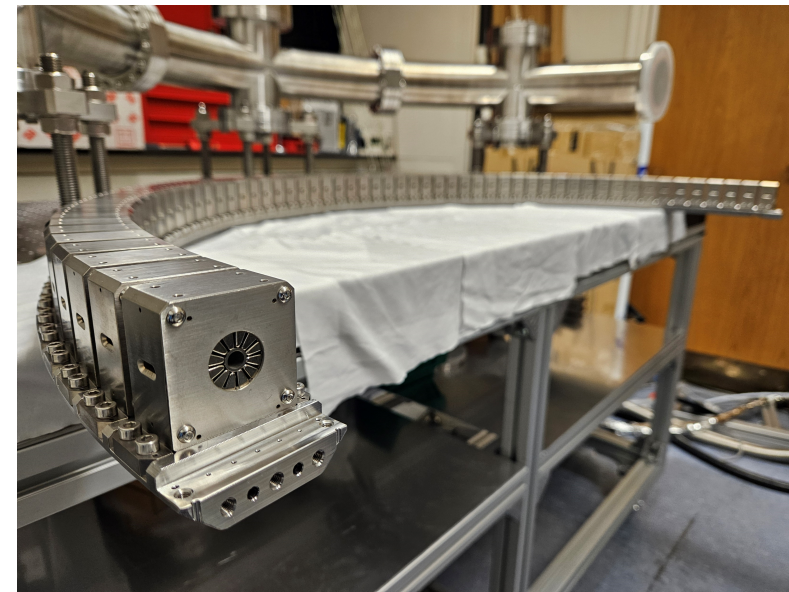
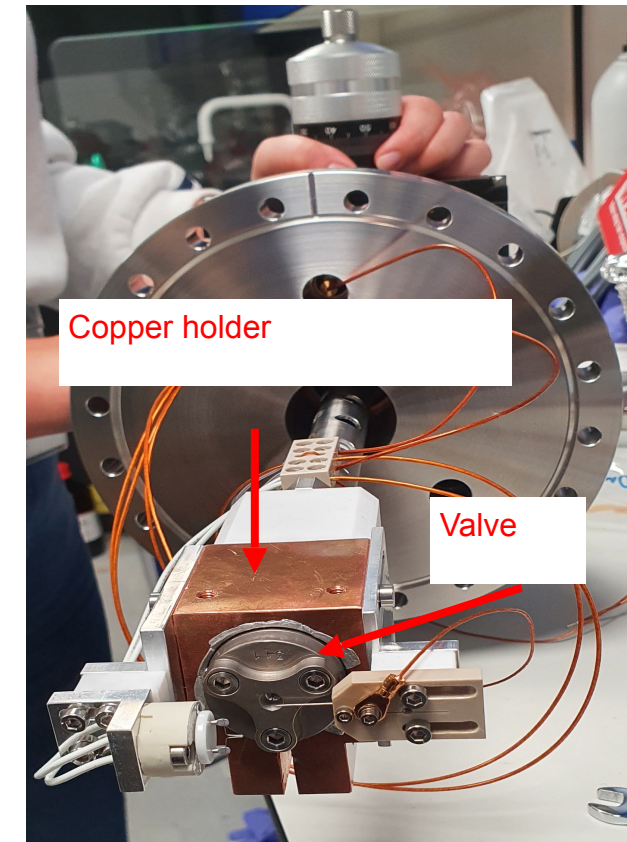

AA S Amad et al 2025 New J. Phys. 27 105006

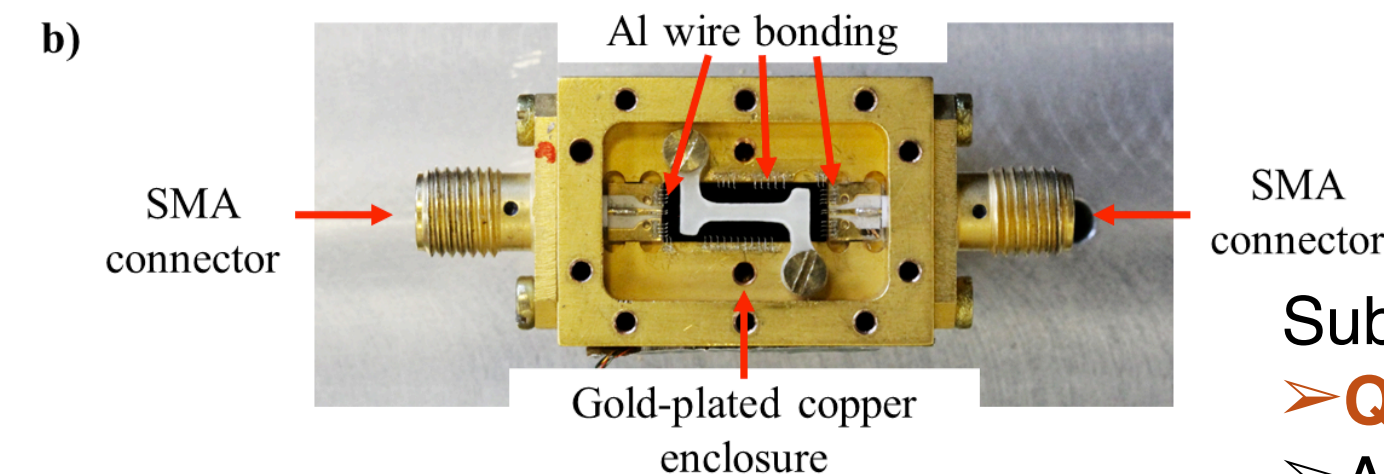
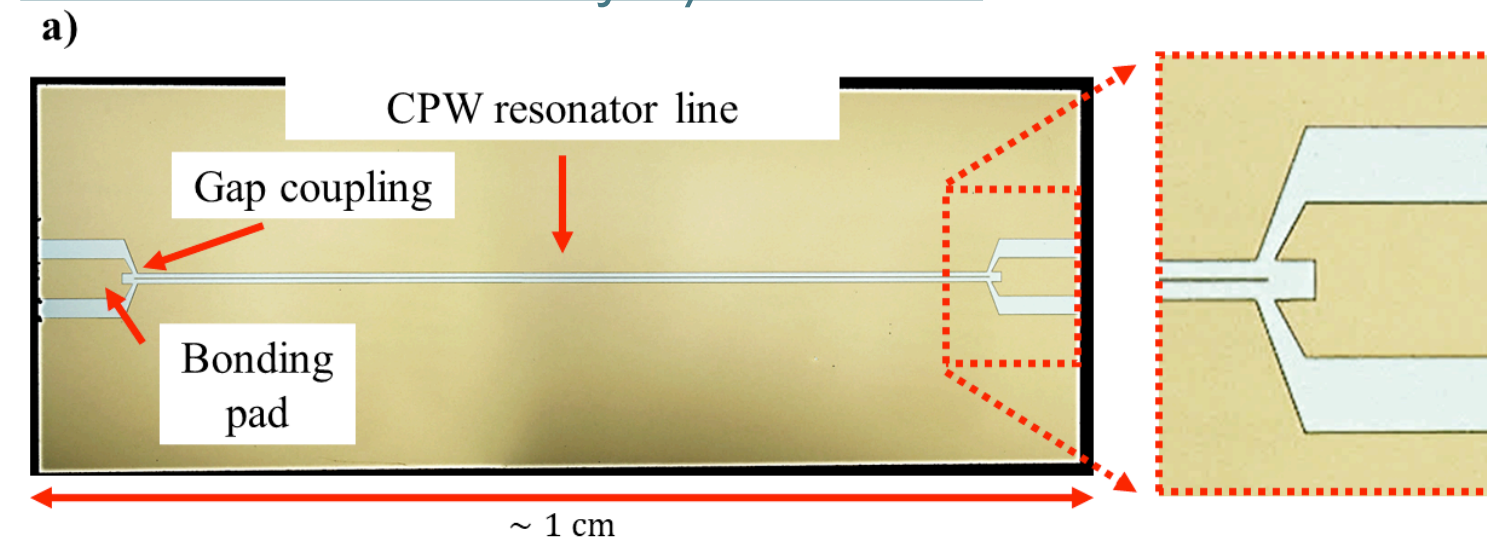

Sub-fw radiated powers, field of view, short observation time

- **Quantum-noise limited** superconducting microwave receivers
- Advanced triggering

Zhao et al., SC Sci.Tech. 36 (2023) 105010

Courtesy of R. Saakyan



Quantum Technologies for Neutrino Mass



Part of **Q**uantum **T**echnologies for **F**undamental **P**hysics programme in the UK

- Addressing key challenges of CRES technology

Observe $O(10^{19})$ T-atoms x yr(s)

- Cryogenic **supersonic atomic T** source
- Magnetic confinement in a **storage ring**
- Multiple CRES modules

Precision *in situ* determination of B- and E-fields

- 3D field mapping with **Rydberg** atoms as **quantum sensors**

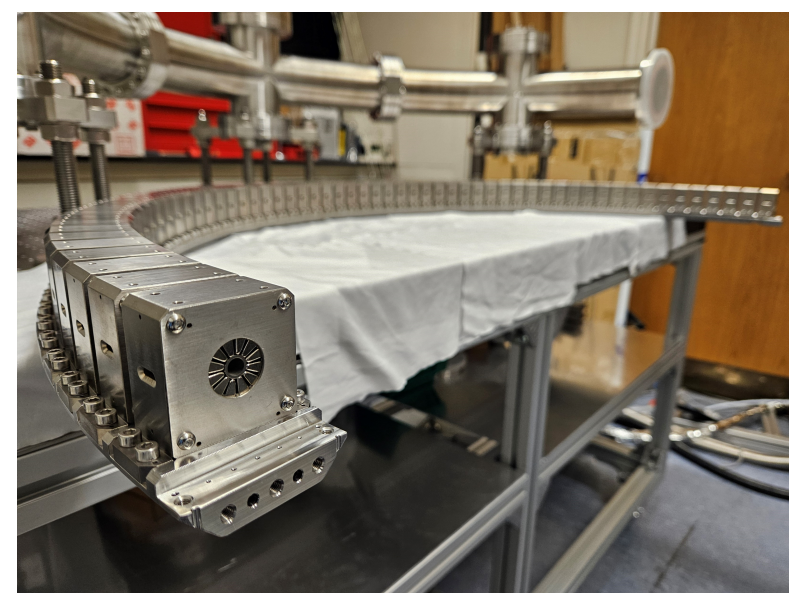
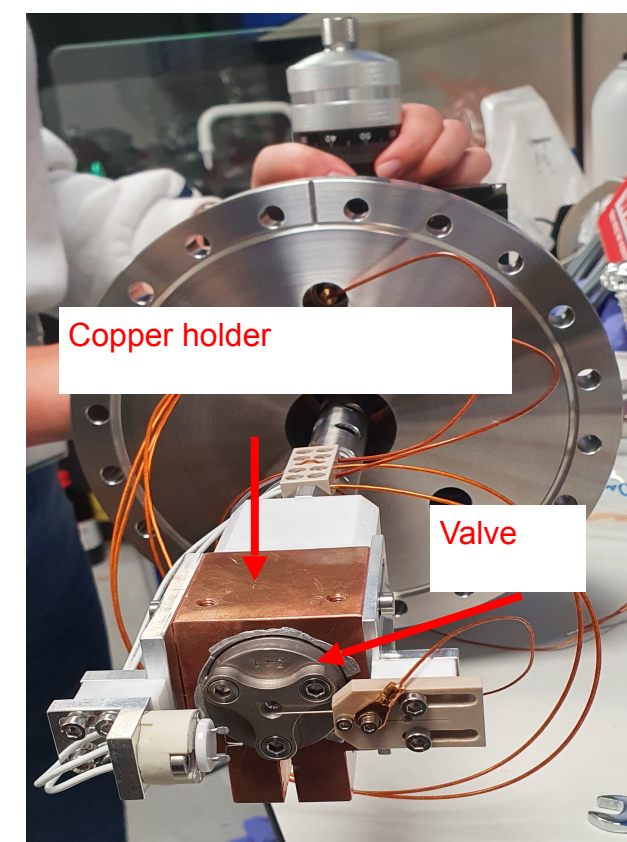
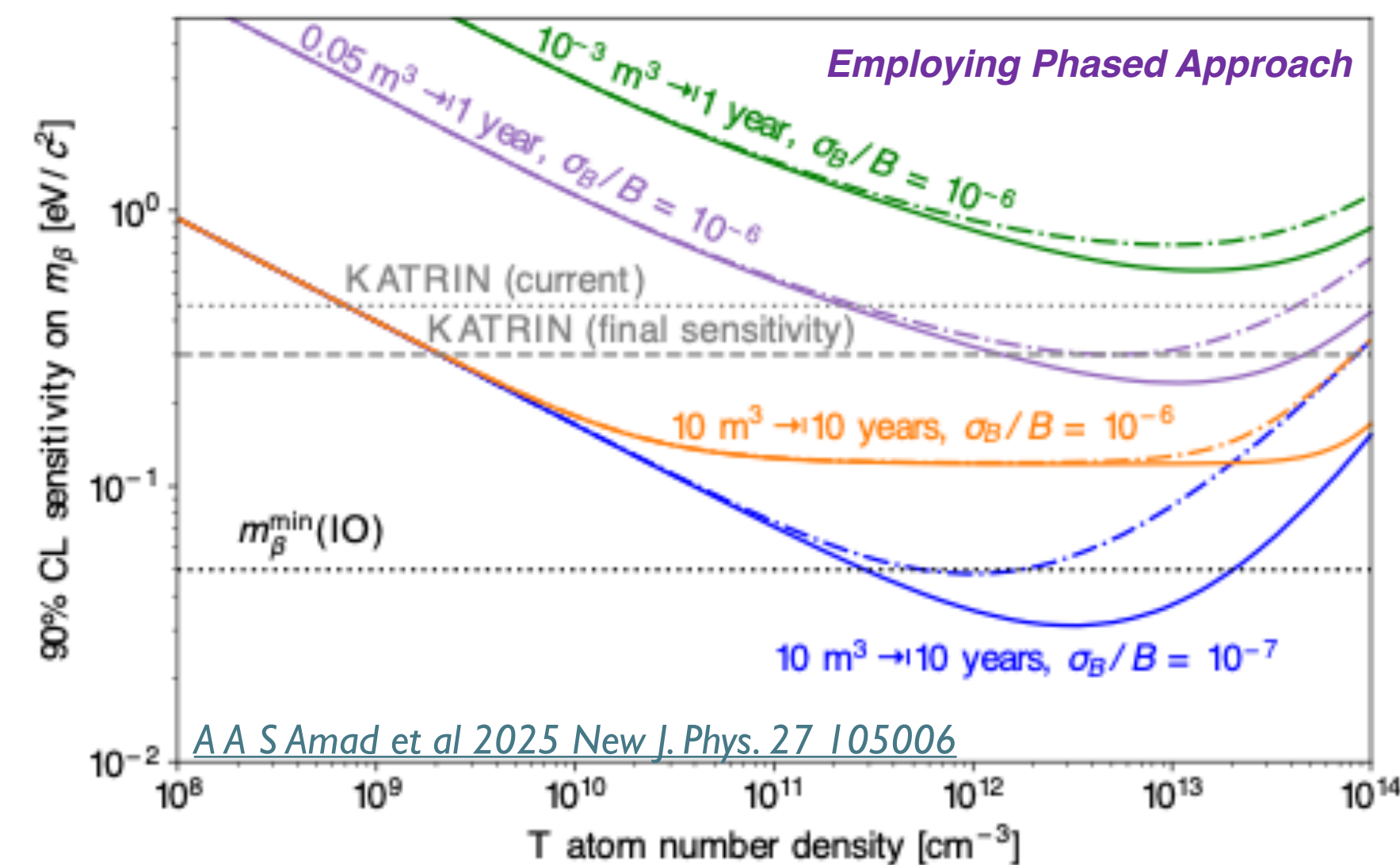
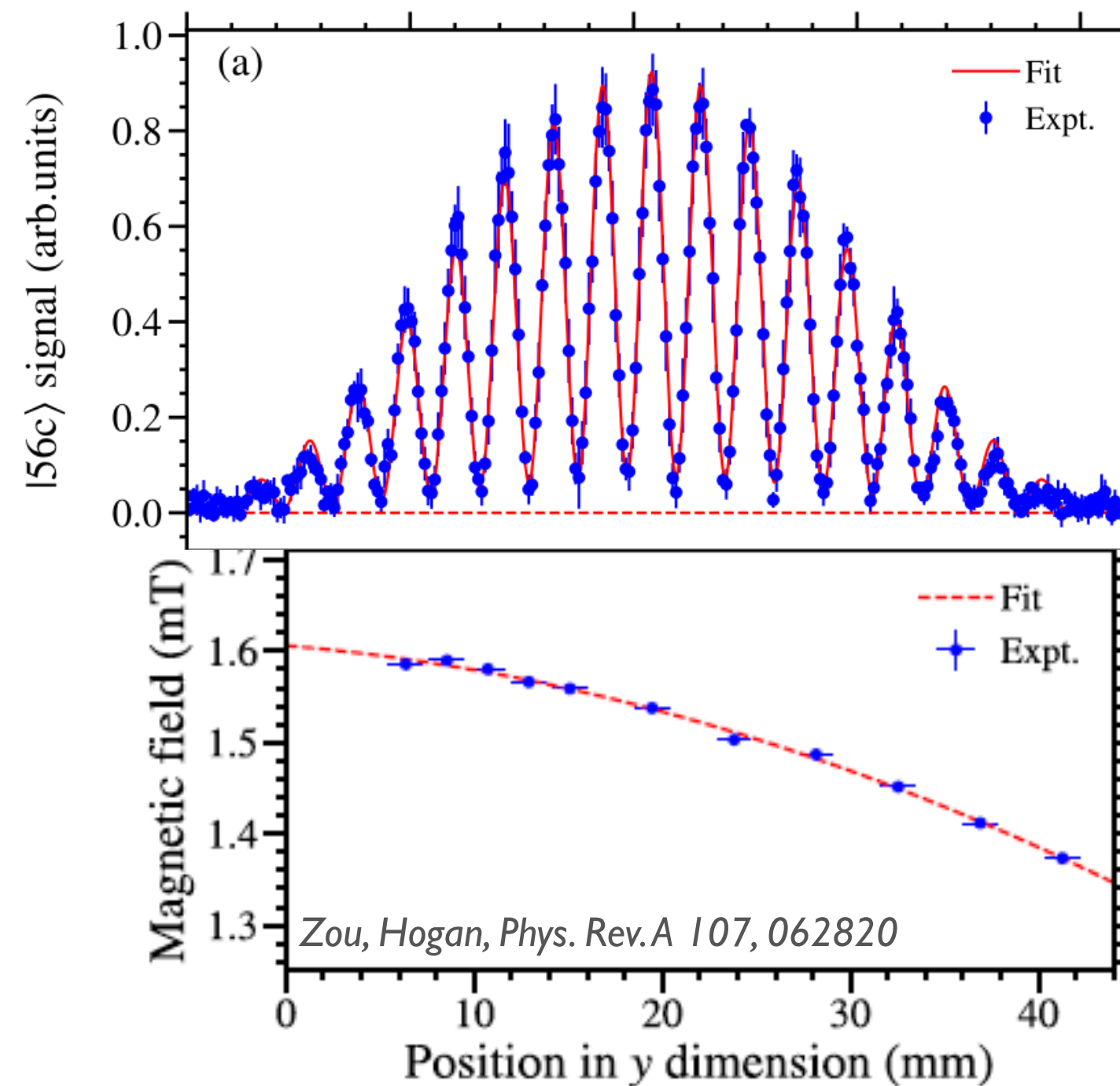
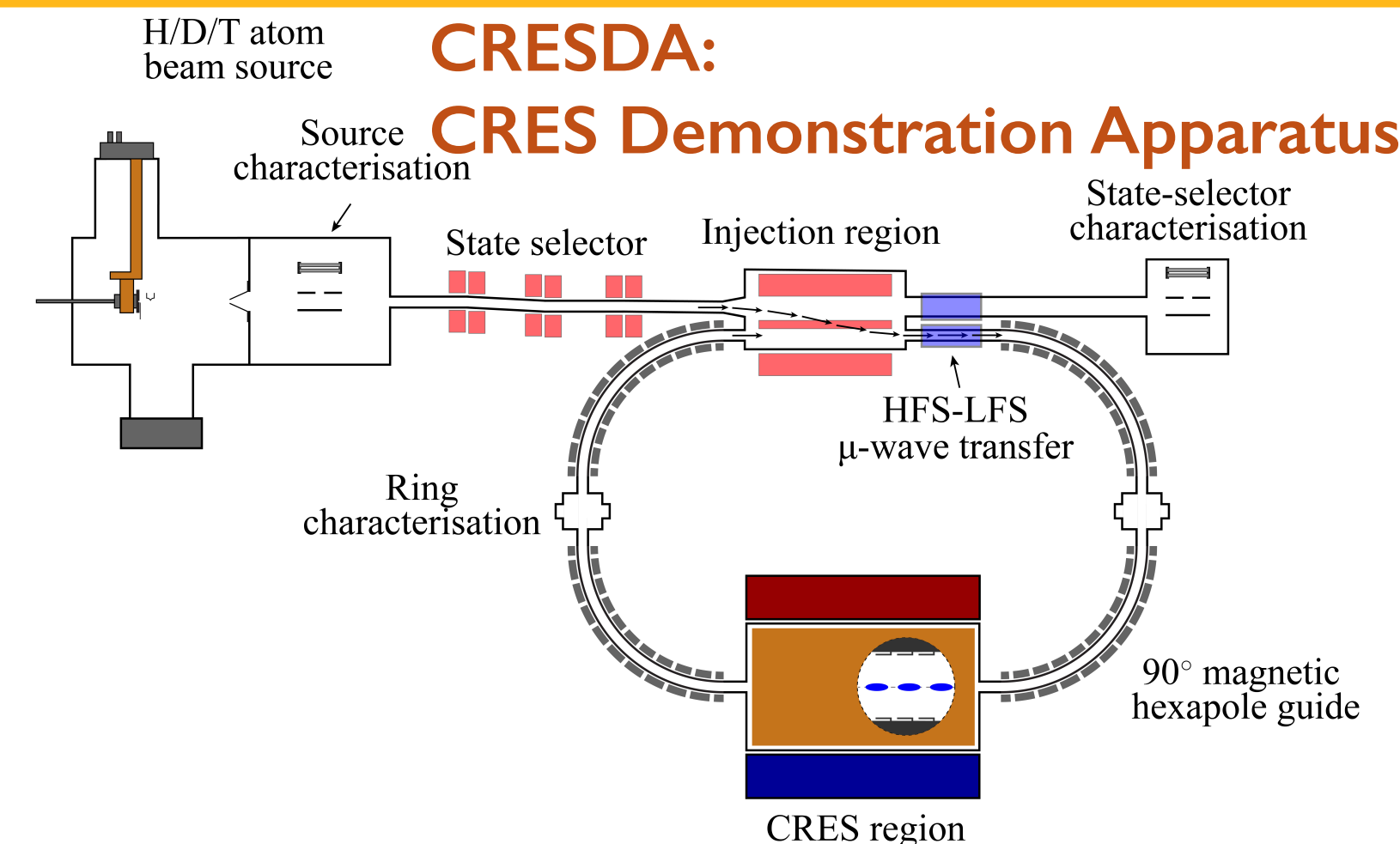

AA S Amad et al 2025 New J. Phys. 27 105006

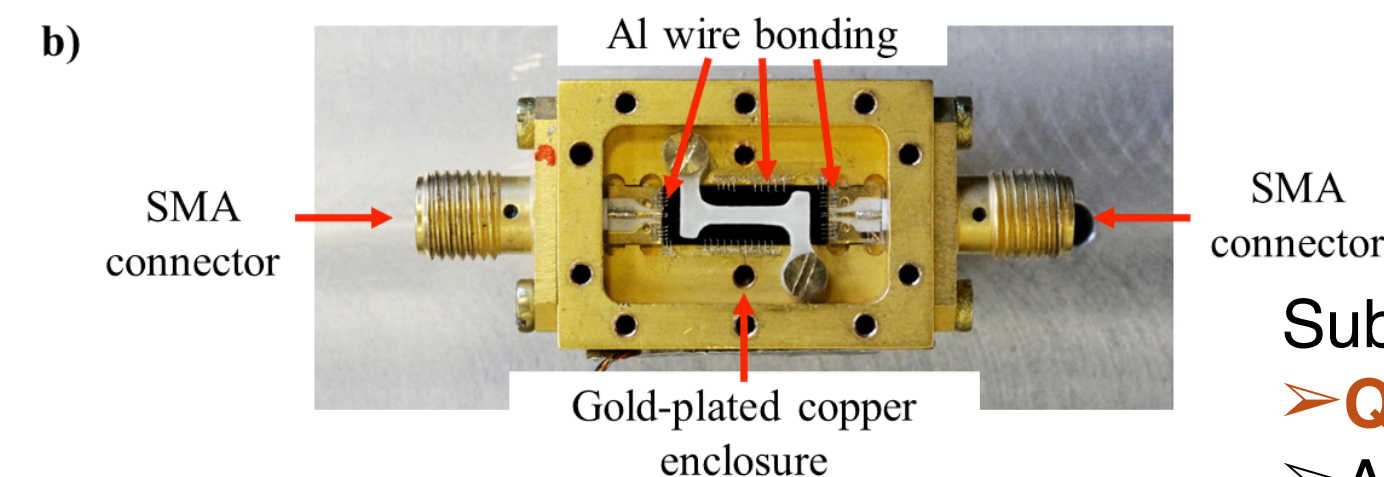
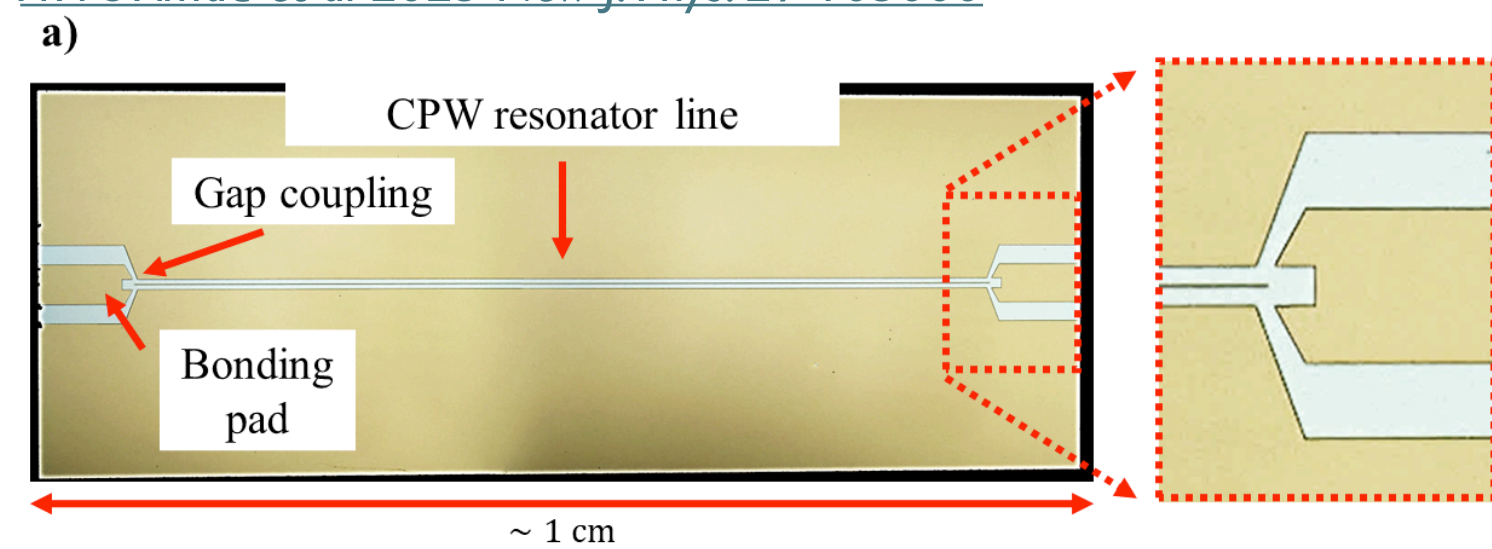

Zhao et al., SC Sci. Tech. 36 (2023) 105010

Sub-fw radiated powers, field of view, short observation time

- **Quantum-noise limited** superconducting microwave receivers
- Advanced triggering

Courtesy of R. Saakyan

Part of **Q**uantum **T**echnologies for **F**undamental **P**hysics programme in the UK

- Addressing key challenges of CRES technology

Observe $O(10^{19})$ T-atoms x yr(s)

- Cryogenic **supersonic atomic T** source
- Magnetic confinement in a **storage ring**
- Multiple CRES modules

Precision *in situ* determination of B- and E-fields

- 3D field mapping with **Rydberg** atoms as **quantum sensors**

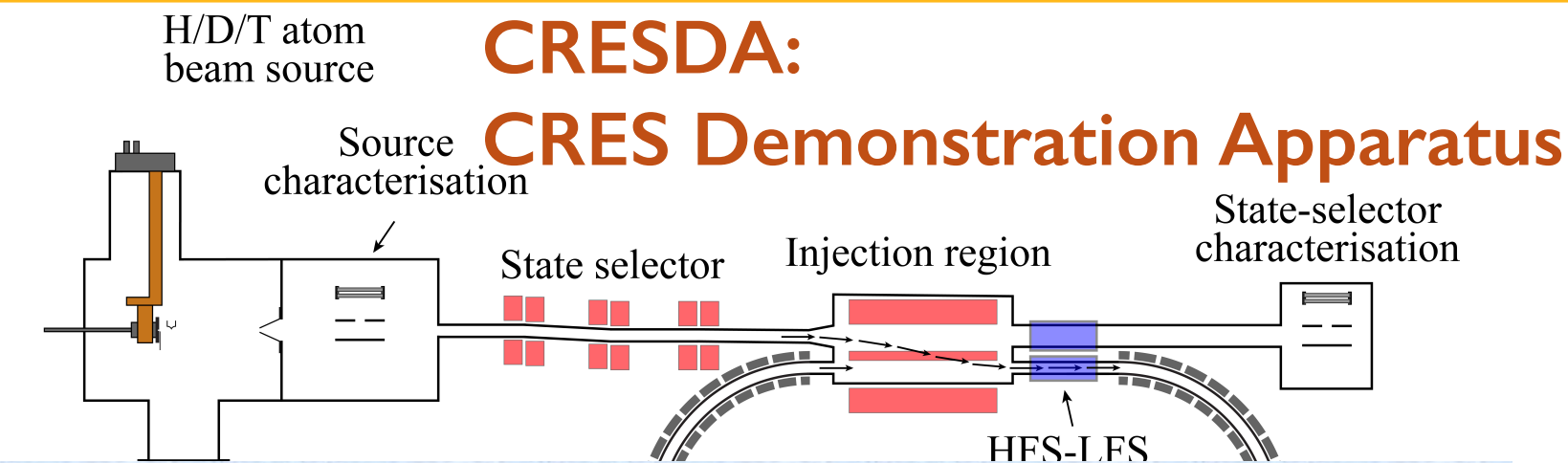

- 2021- 2025: CRESDA0. Key technologies demonstration
- 2026 - 2030: CRESDA-Tritium. System demonstration, scaling, tritium readiness
- 2030 -: Neutrino mass experiment
 - 100 meV → 50 meV and beyond

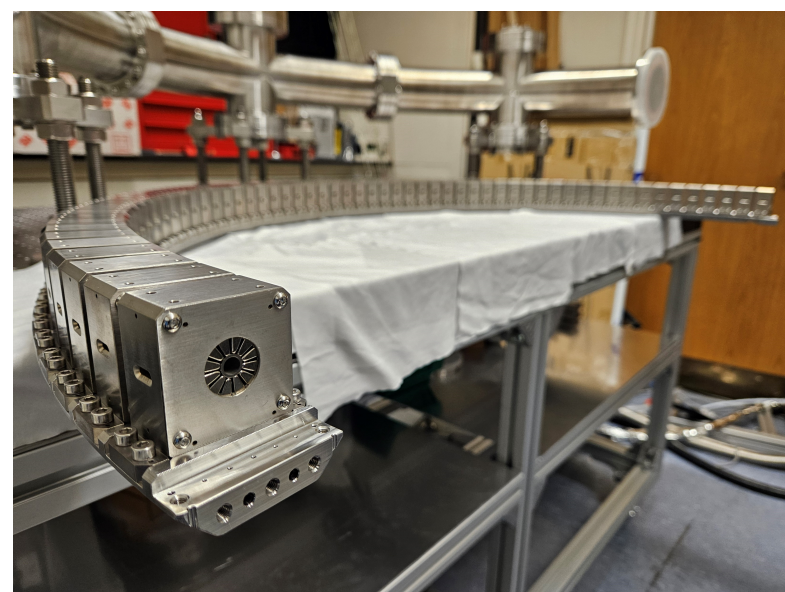
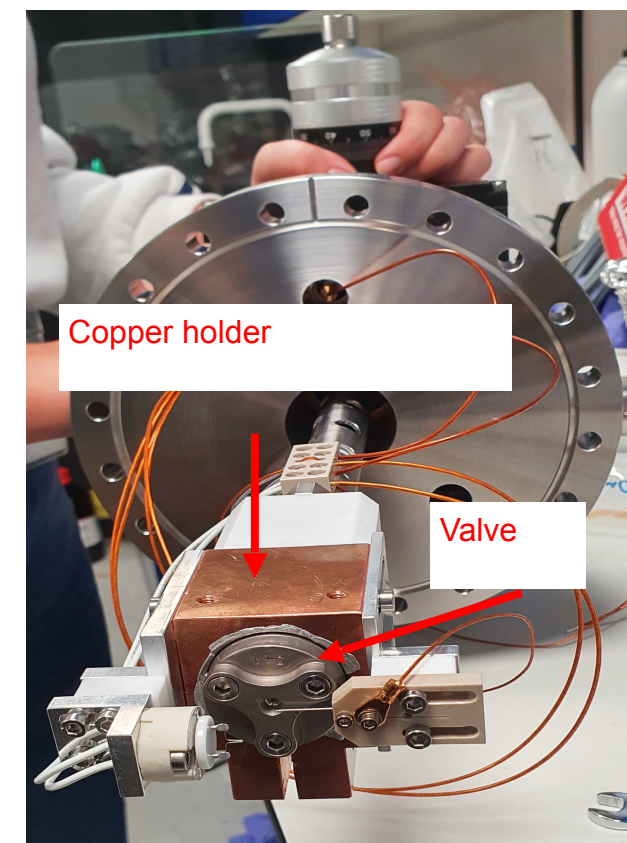
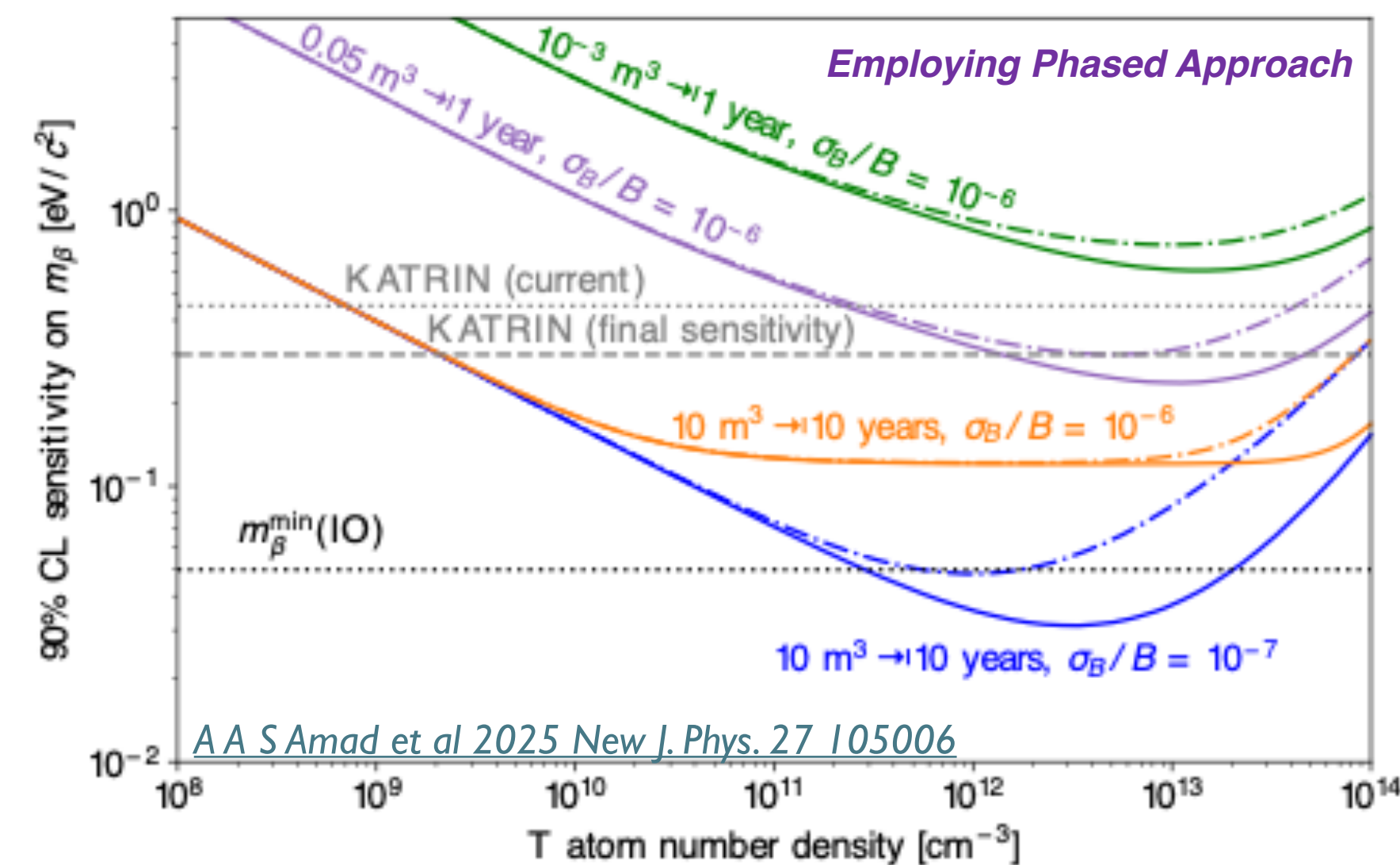
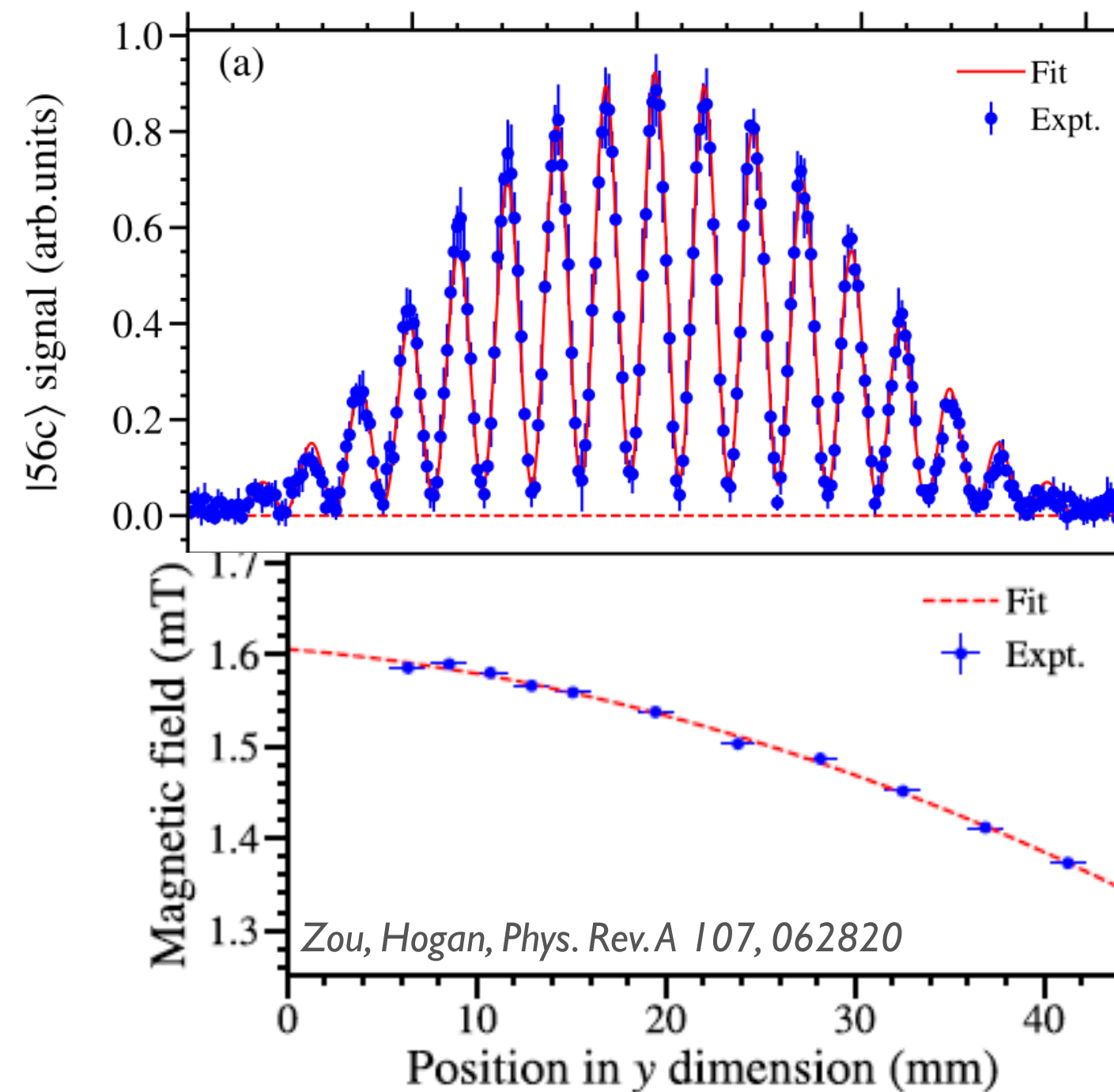

AA S Amad et al 2025 New J. Phys. 27 105006

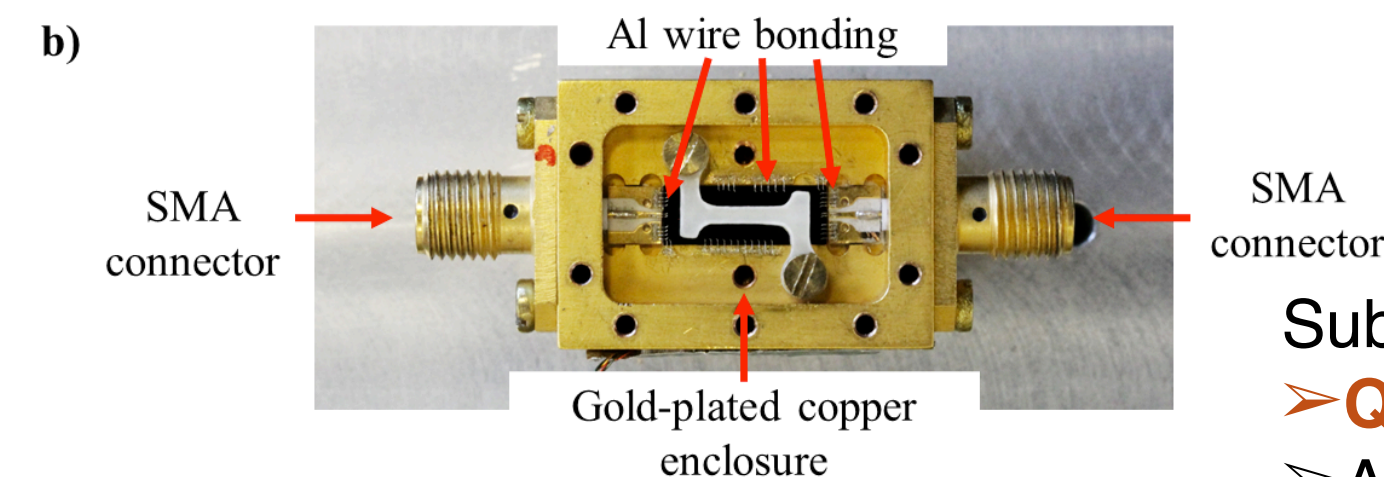
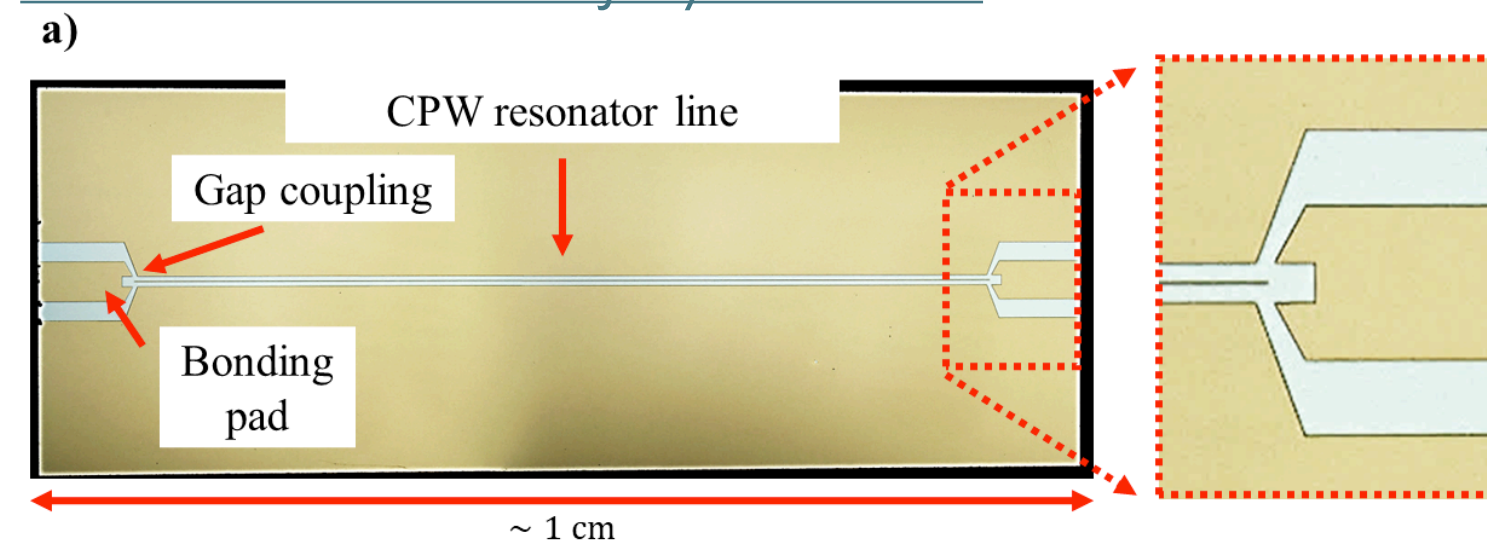

Sub-fw radiated powers, field of view, short observation time

- Quantum-noise limited superconducting microwave receivers
- Advanced triggering

Zhao et al., SC Sci. Tech. 36 (2023) 105010

Courtesy of R. Saakyan

Part of **Q**uantum **T**echnologies for **F**undamental **P**hysics programme in the UK

- Addressing key challenges of CRES technology

Observe $O(10^{19})$ T-atoms x yr(s)

- Cryogenic **supersonic atomic T** source
- Magnetic confinement in a **storage ring**
- Multiple CRES modules

Precision *in situ* determination of B- and E-fields

- 3D field mapping with **Rydberg** atoms as **quantum sensors**

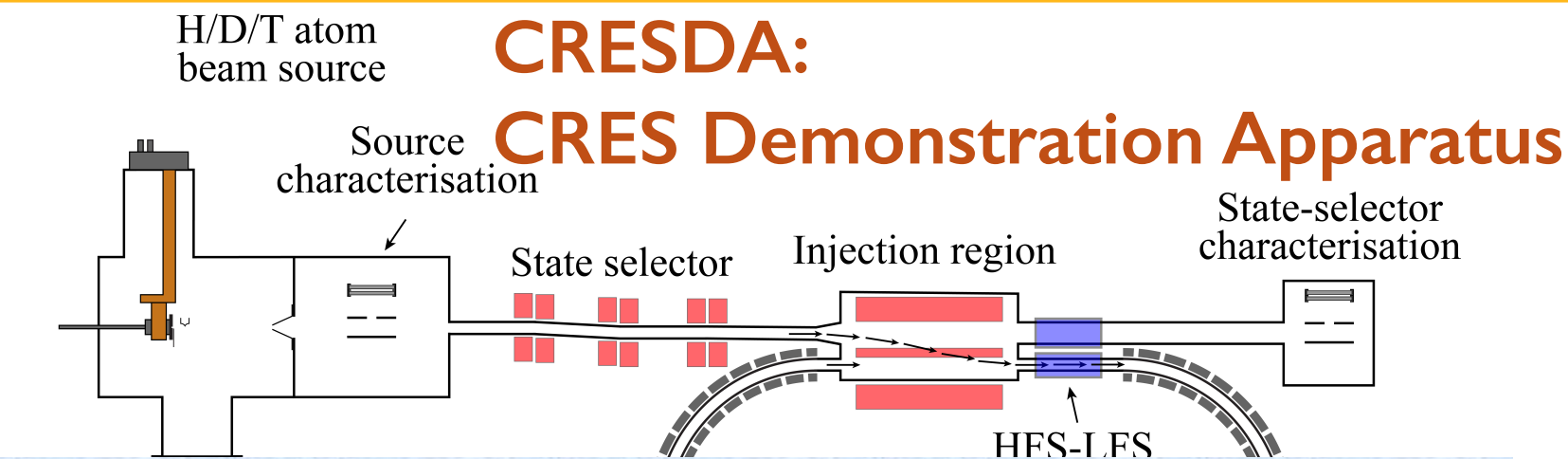

- 2021- 2025: CRESDA0. Key technologies demonstration
- 2026 - 2030: CRESDA-Tritium. System demonstration, scaling, tritium readiness
- 2030 -: Neutrino mass experiment
 - → 100 meV → 50 meV and beyond

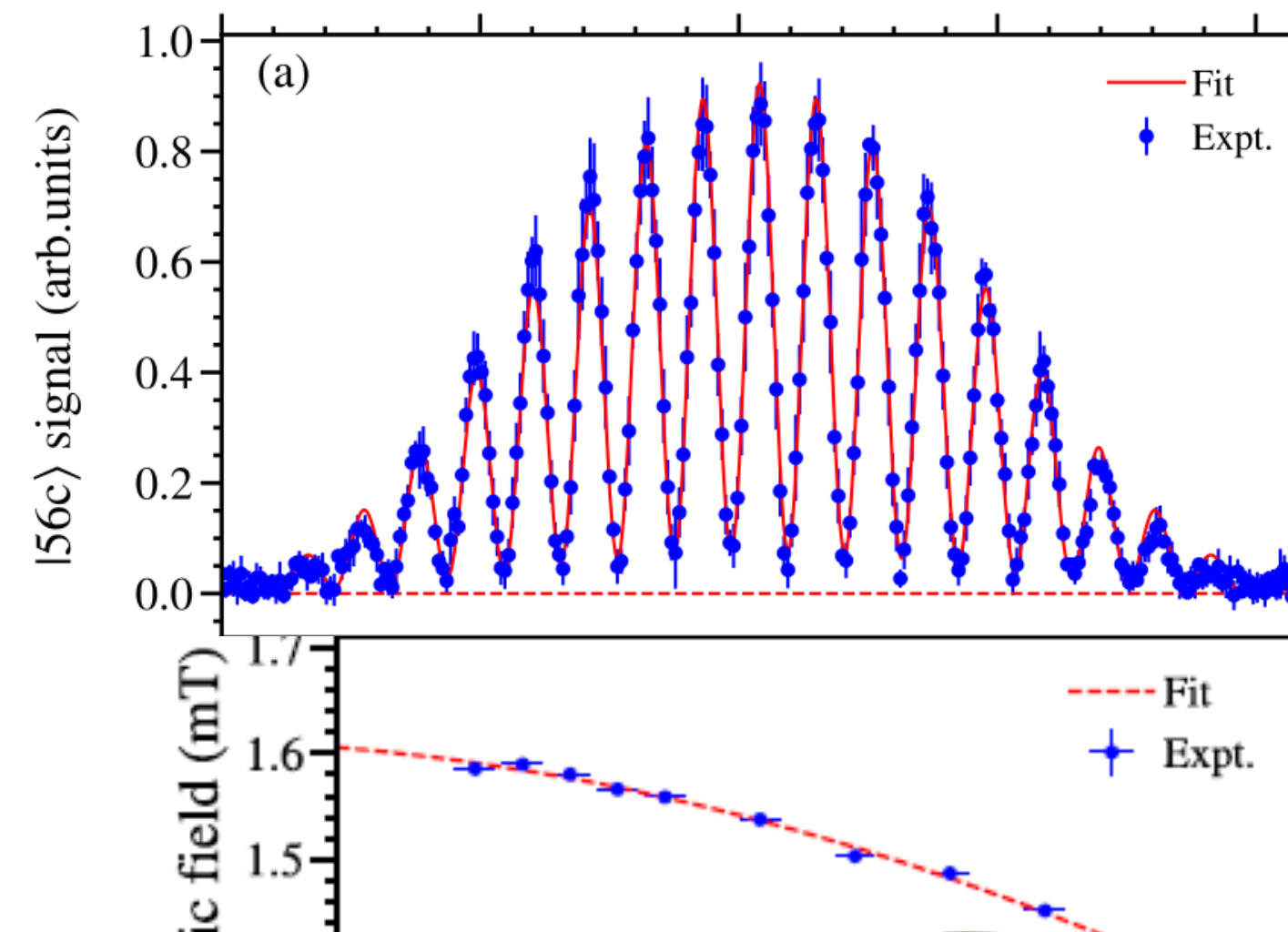

See poster by N. Higginbotham:
 "Machine-Learning-Driven Signal Processing and Event Reconstruction for Cyclotron Radiation Emission Spectroscopy in QTNM"

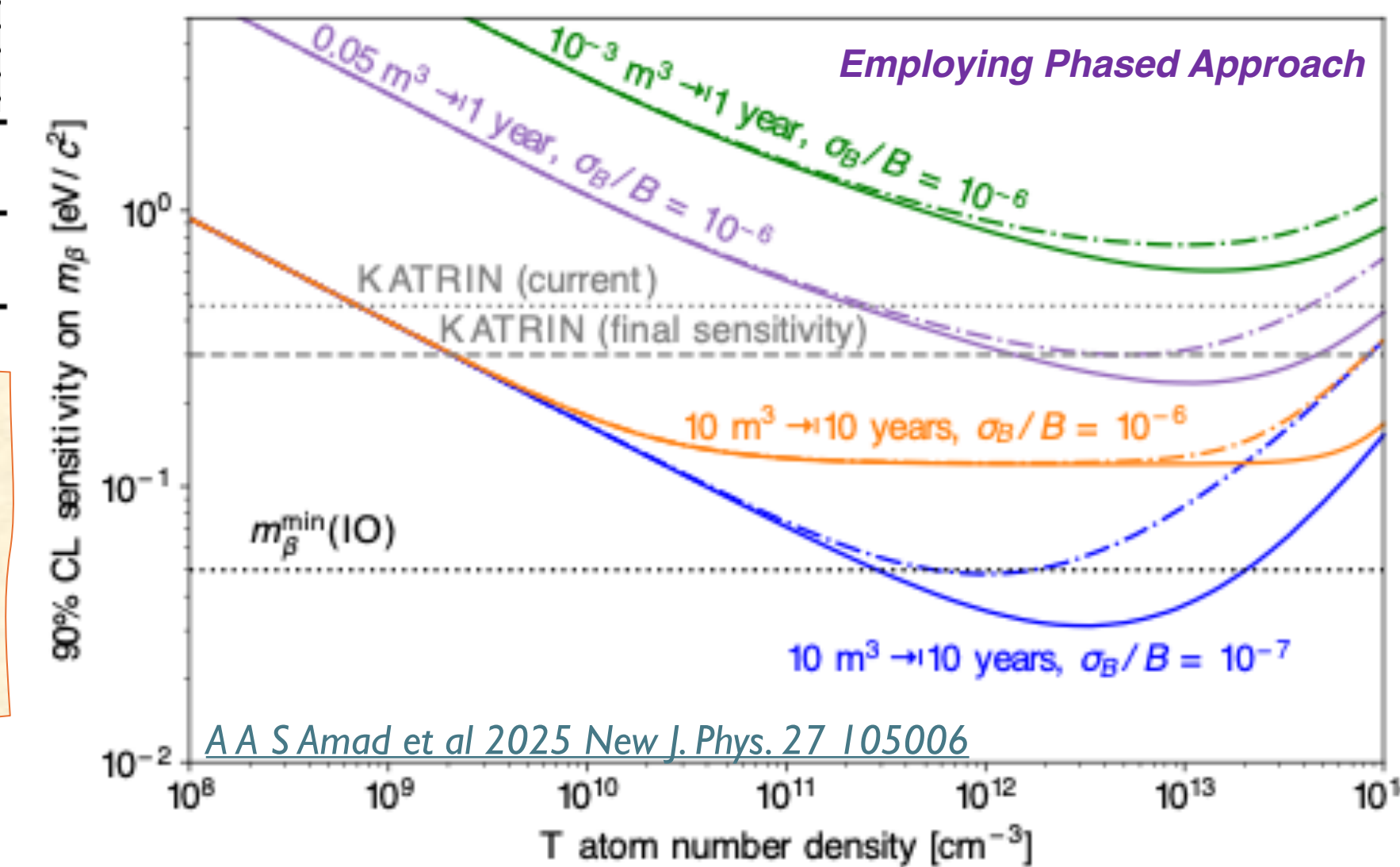

AA SAmad et al 2025 New J. Phys. 27 105006

Courtesy of R. Saakyan

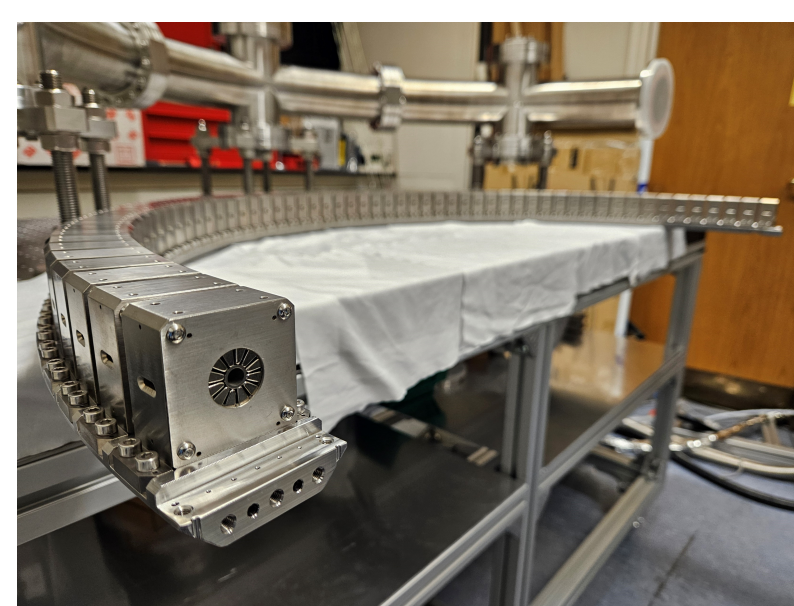
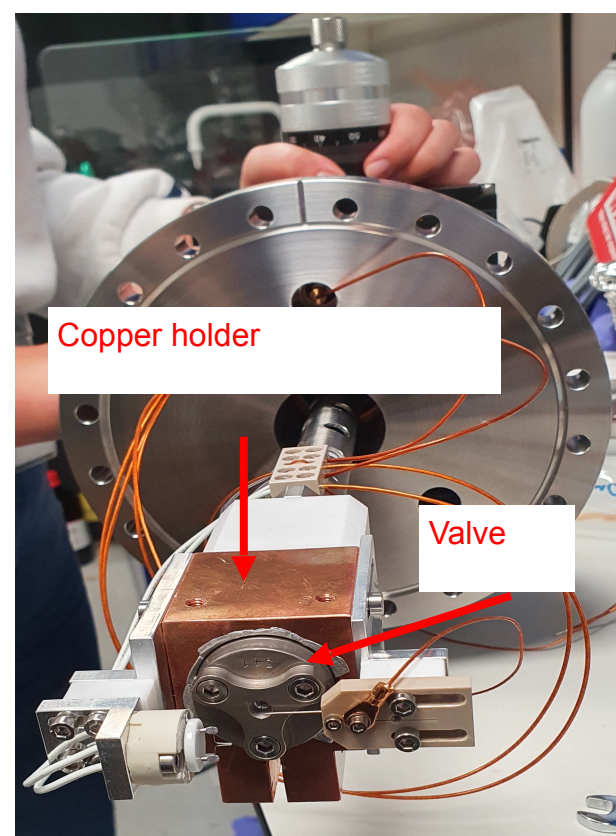

AA SAmad et al 2025 New J. Phys. 27 105006

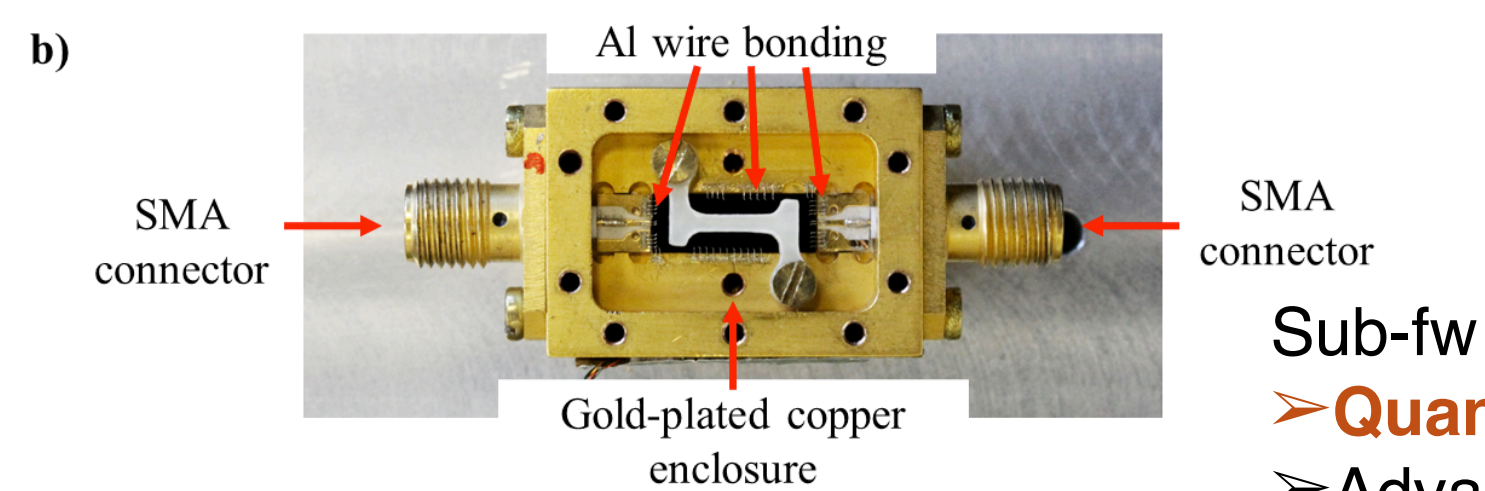
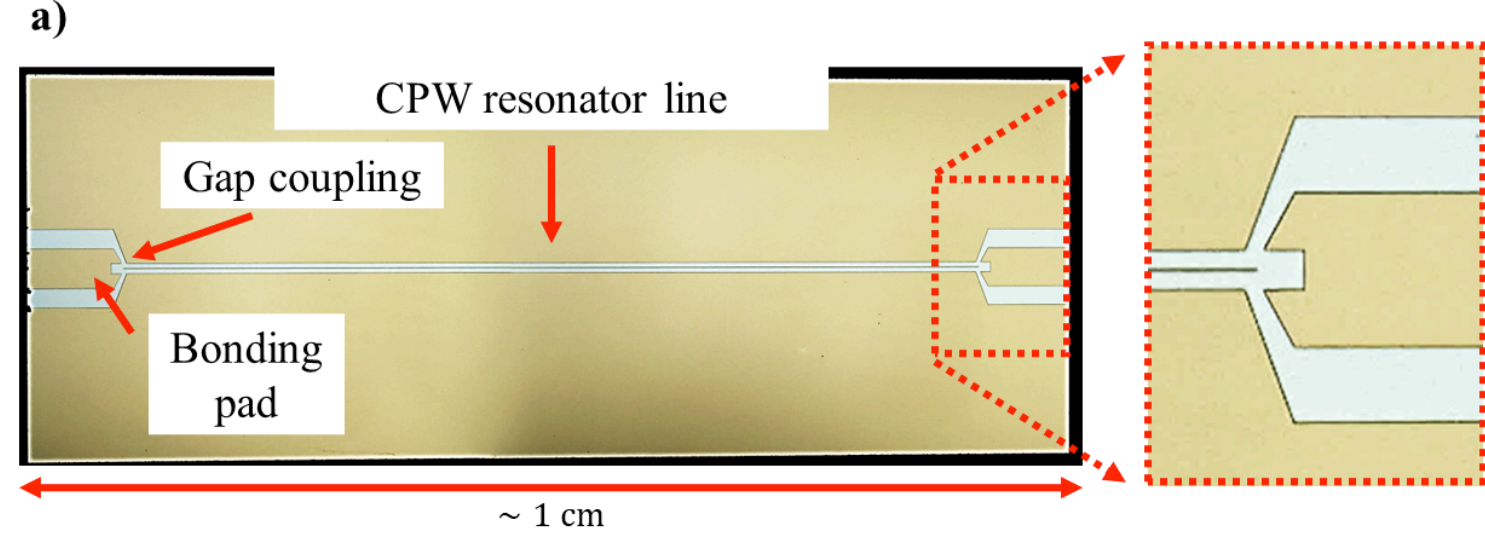

Zhao et al., SC Sci. Tech. 36 (2023) 105010

- Sub-fw radiated powers, field of view, short observation time
- **Quantum-noise limited** superconducting microwave receivers
- Advanced triggering

- Aims to detect the cosmic neutrino background (relic neutrinos) via capture on atomic tritium
- Also targets a direct neutrino-mass measurement

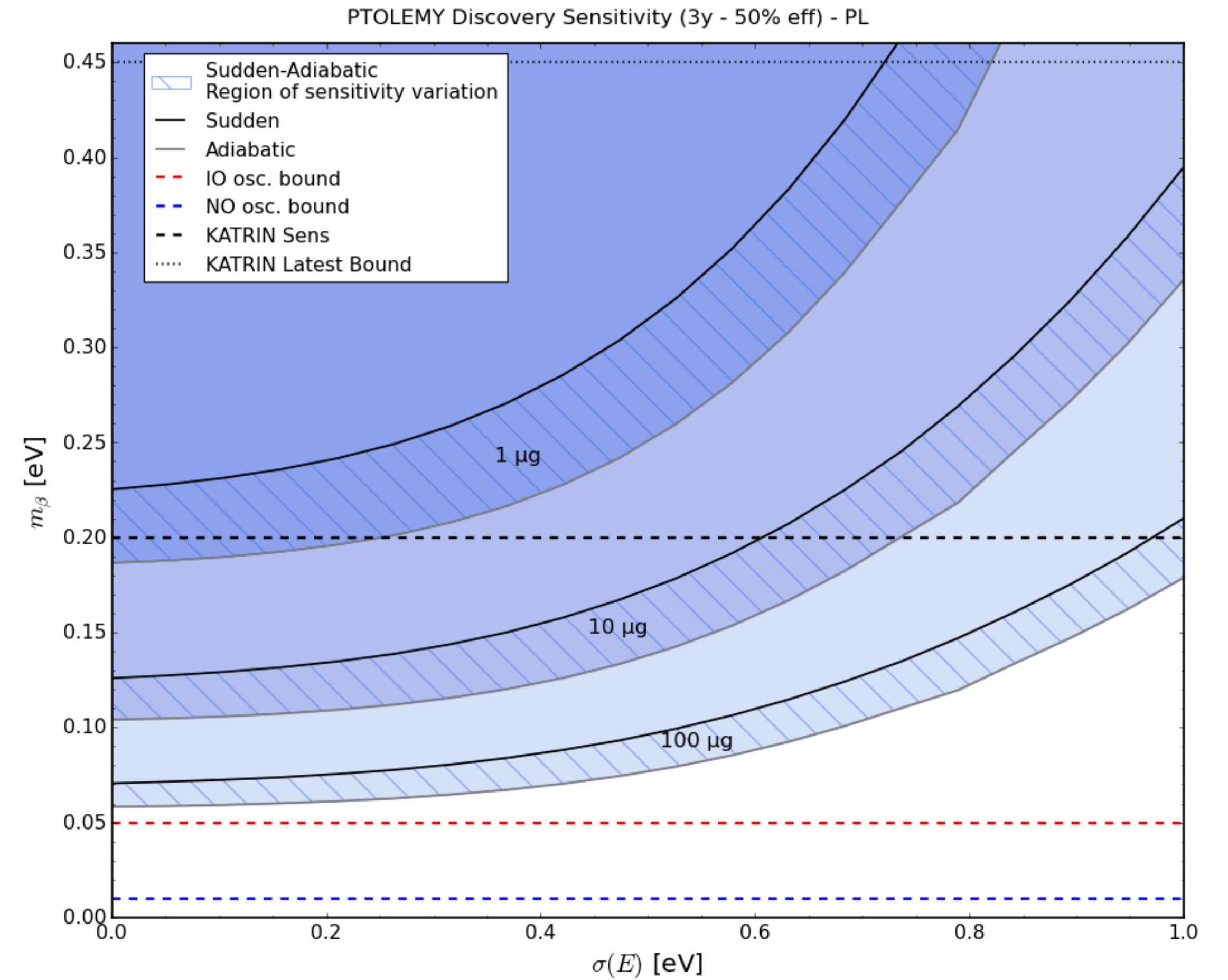
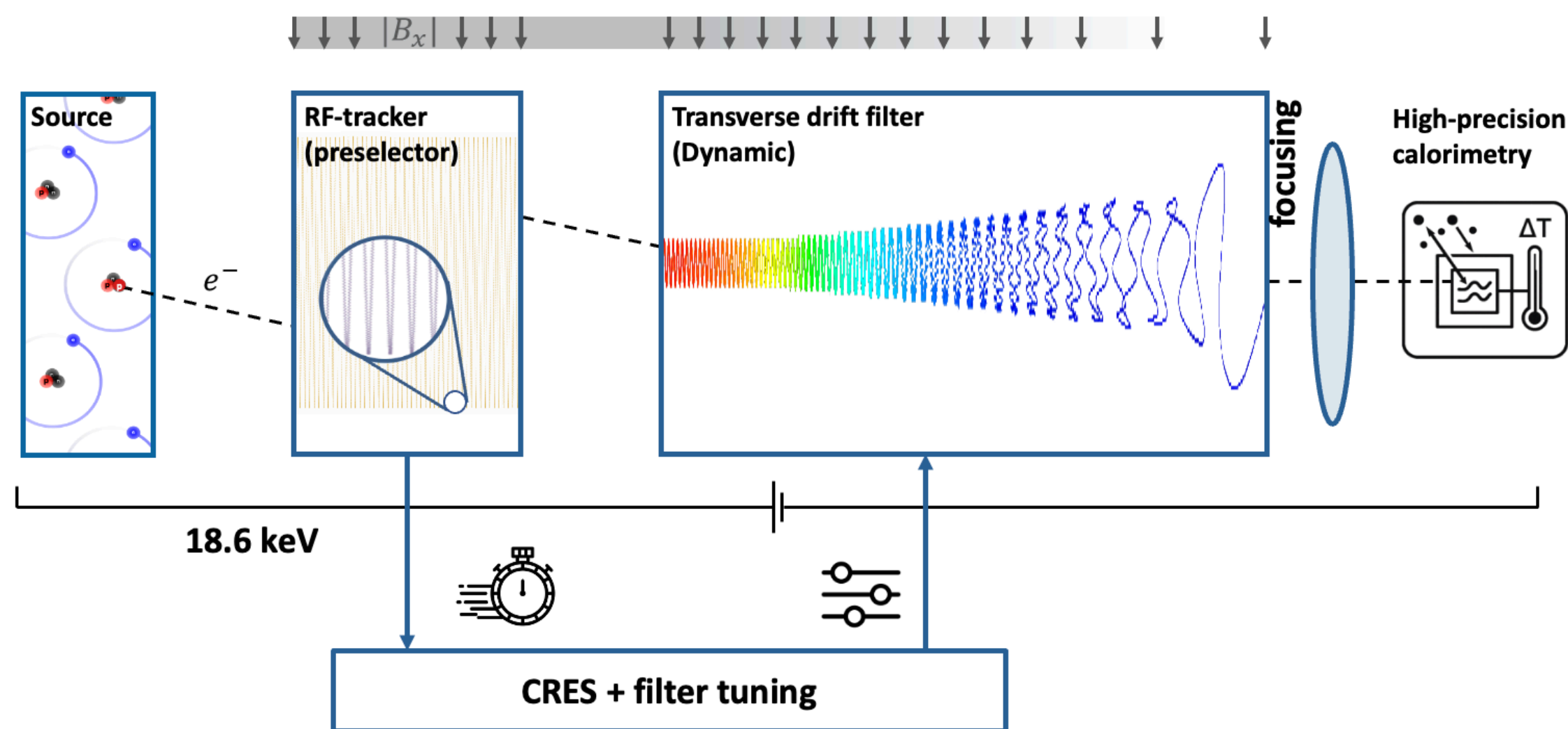
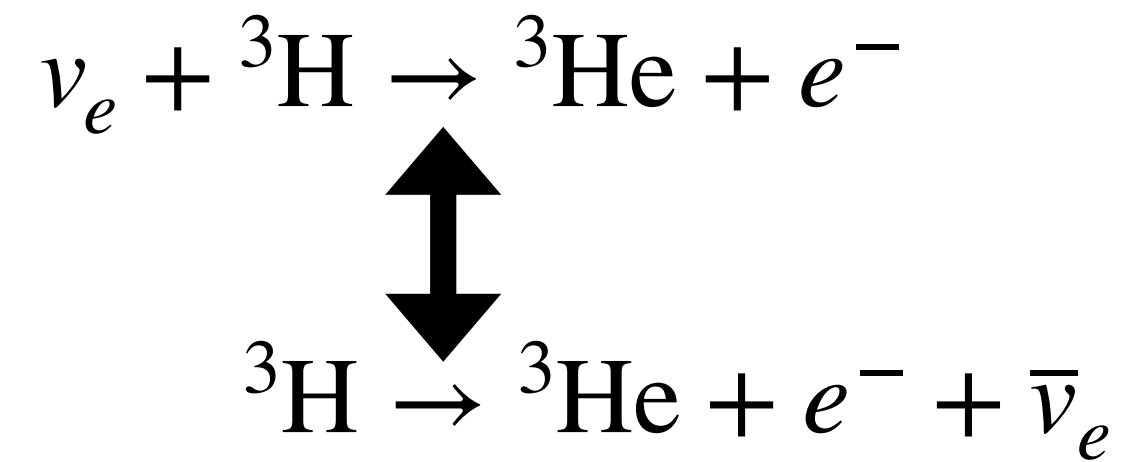

- Aims to detect the cosmic neutrino background (relic neutrinos) via capture on atomic tritium
- Also targets a direct neutrino-mass measurement

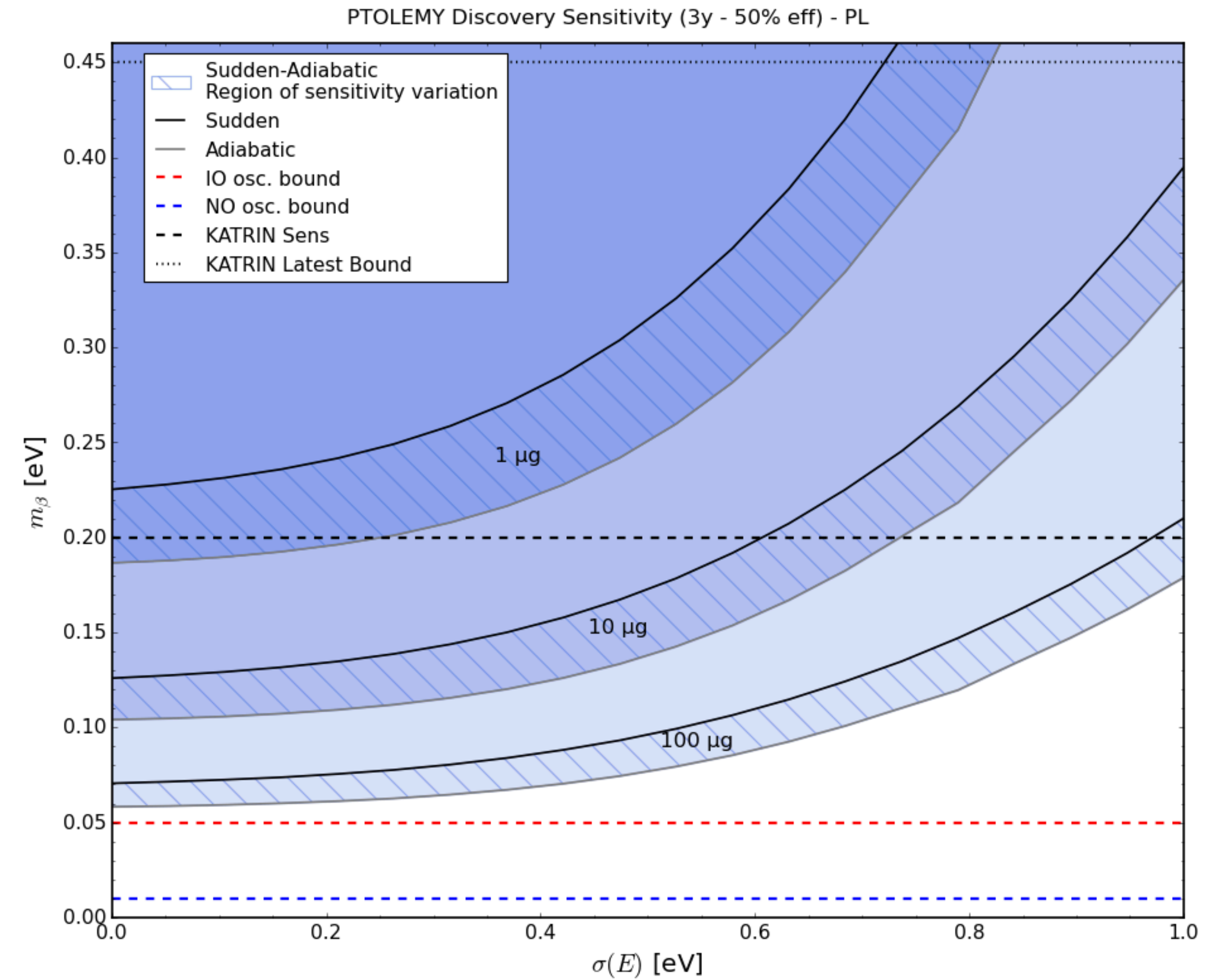
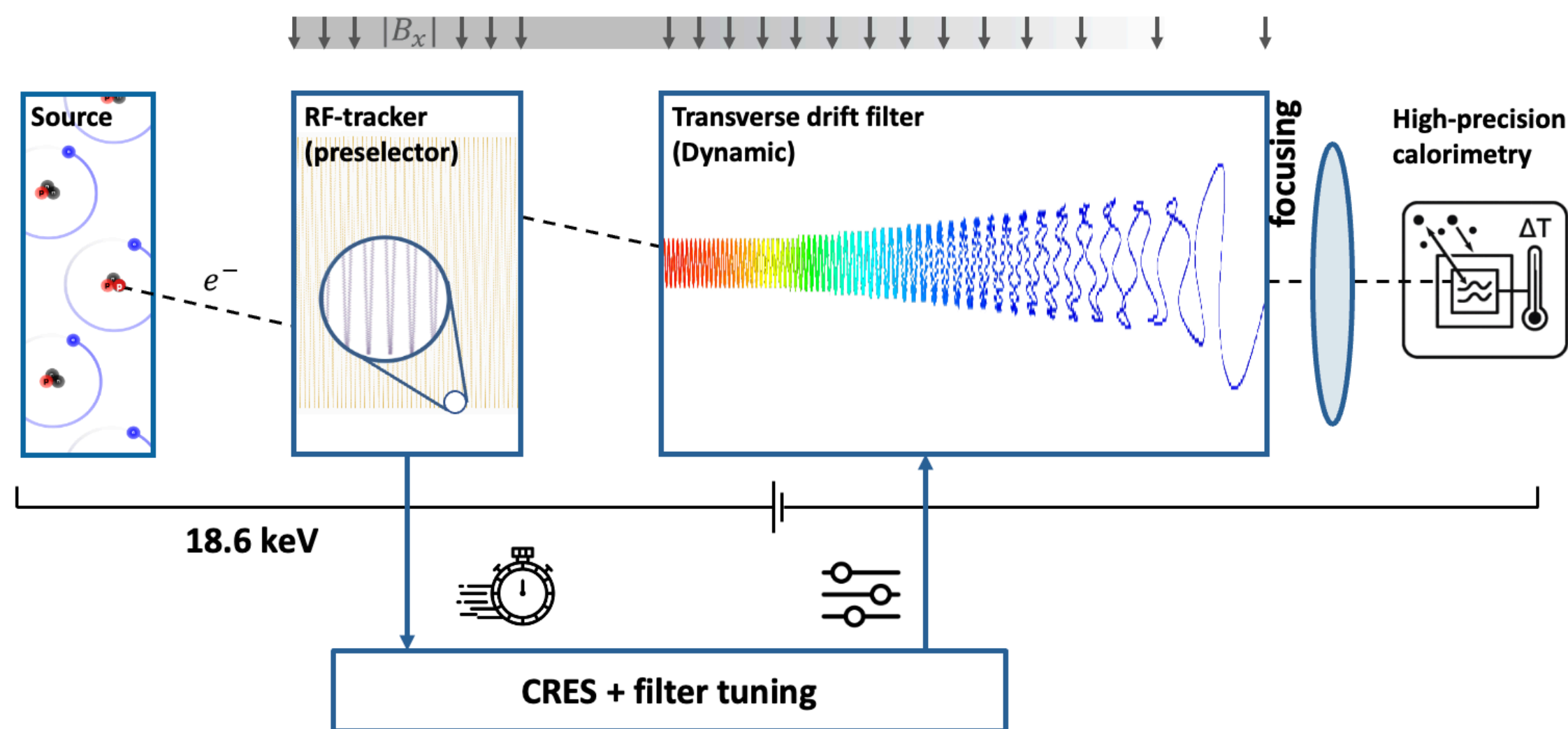
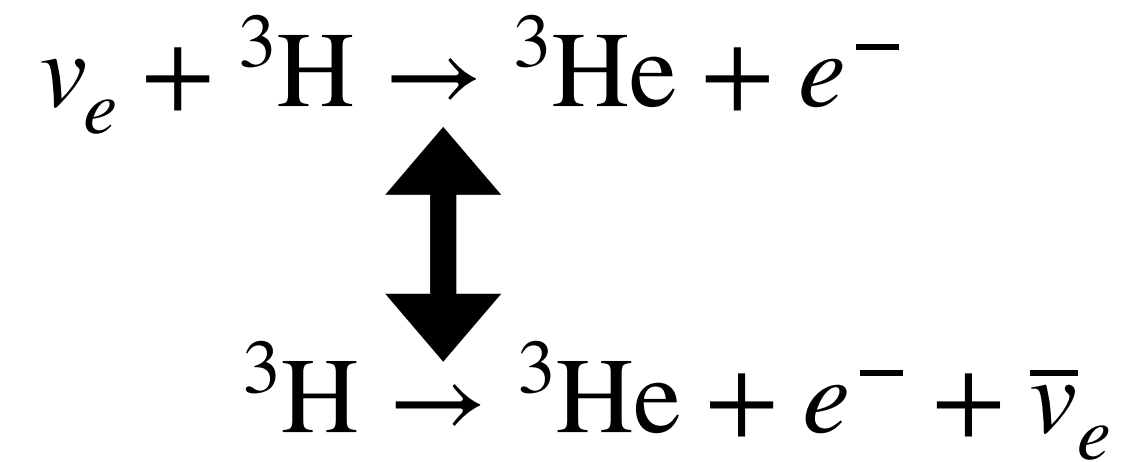

See C. Tully's talk on Thursday

PROJECT 8





Project 8 Phased Approach

PROJECT 8



Phase-I
Proof of principle
 ^{83m}Kr spectrum

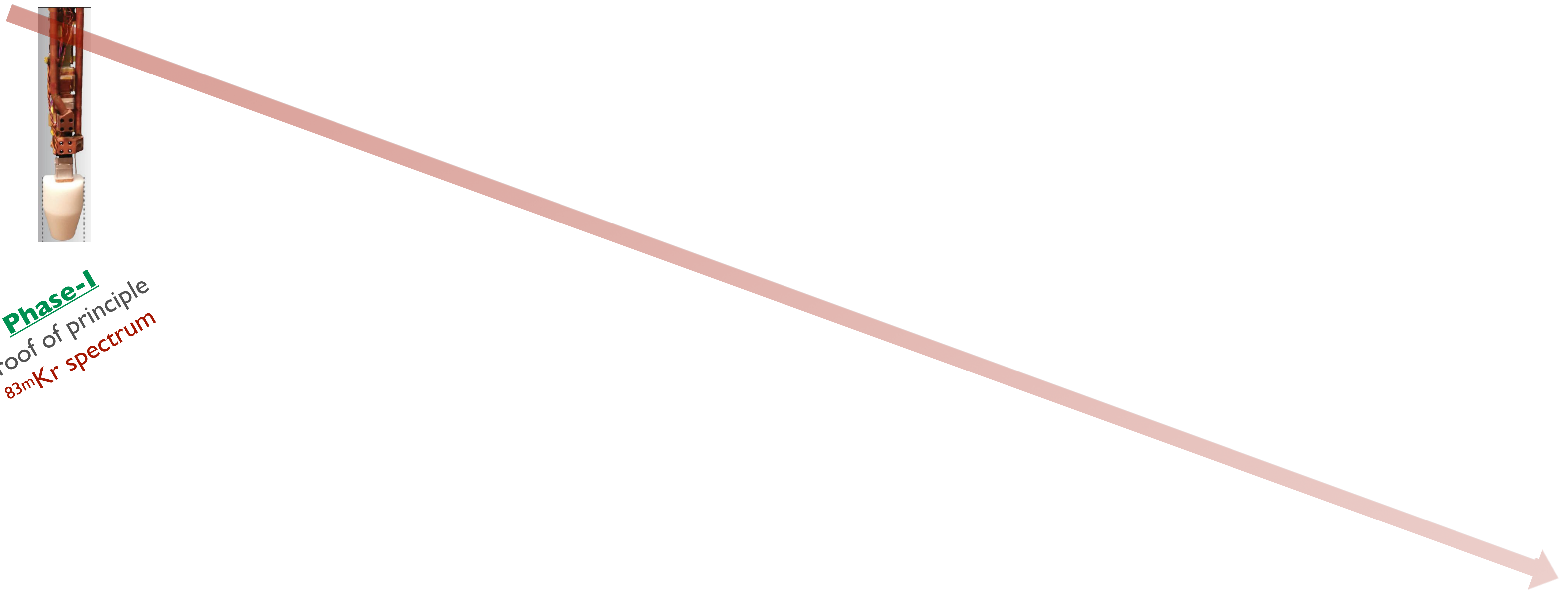



Project 8 Phased Approach

PROJECT 8



Phase-I
Proof of principle
 ^{83m}Kr spectrum

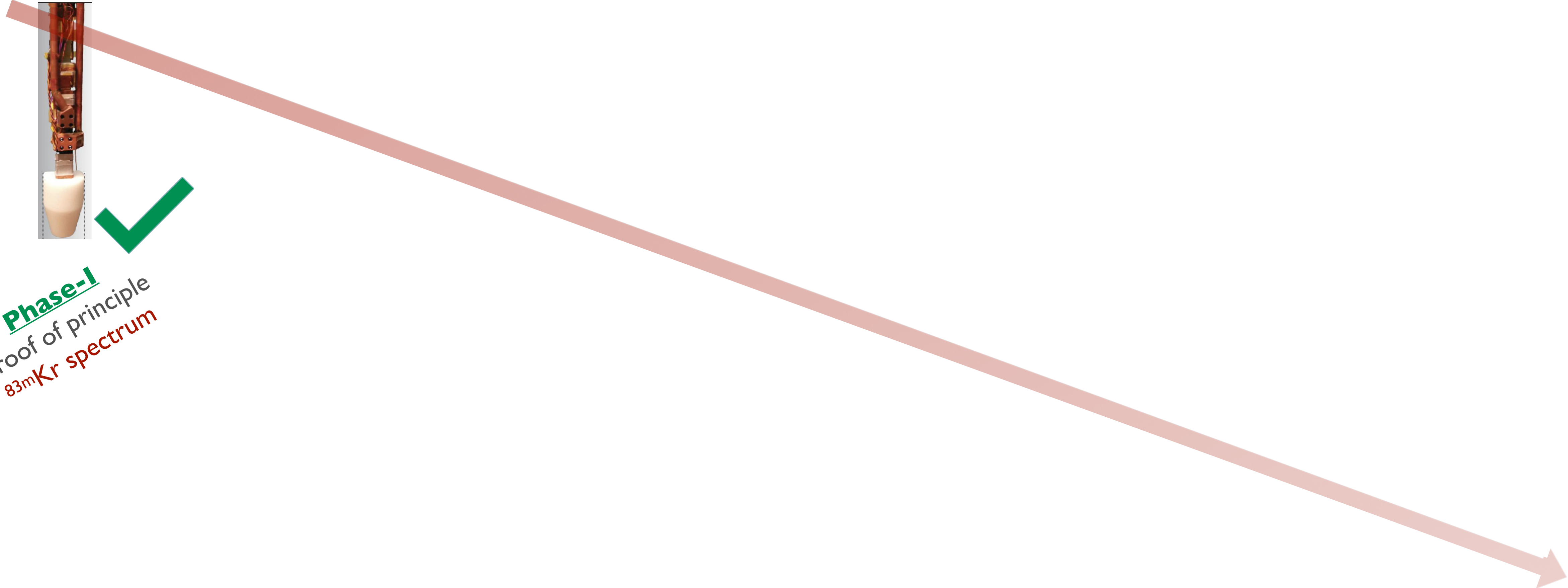



Project 8 Phased Approach

PROJECT 8



Phase-I
Proof of principle
 ^{83m}Kr spectrum



Phase-II
 T_2 Spectrum and systematics
End point and neutrino mass



Project 8 Phased Approach

PROJECT 8



Phase-I
Proof of principle
 ^{83m}Kr spectrum



Phase-II
 T_2 Spectrum and systematics
End point and neutrino mass

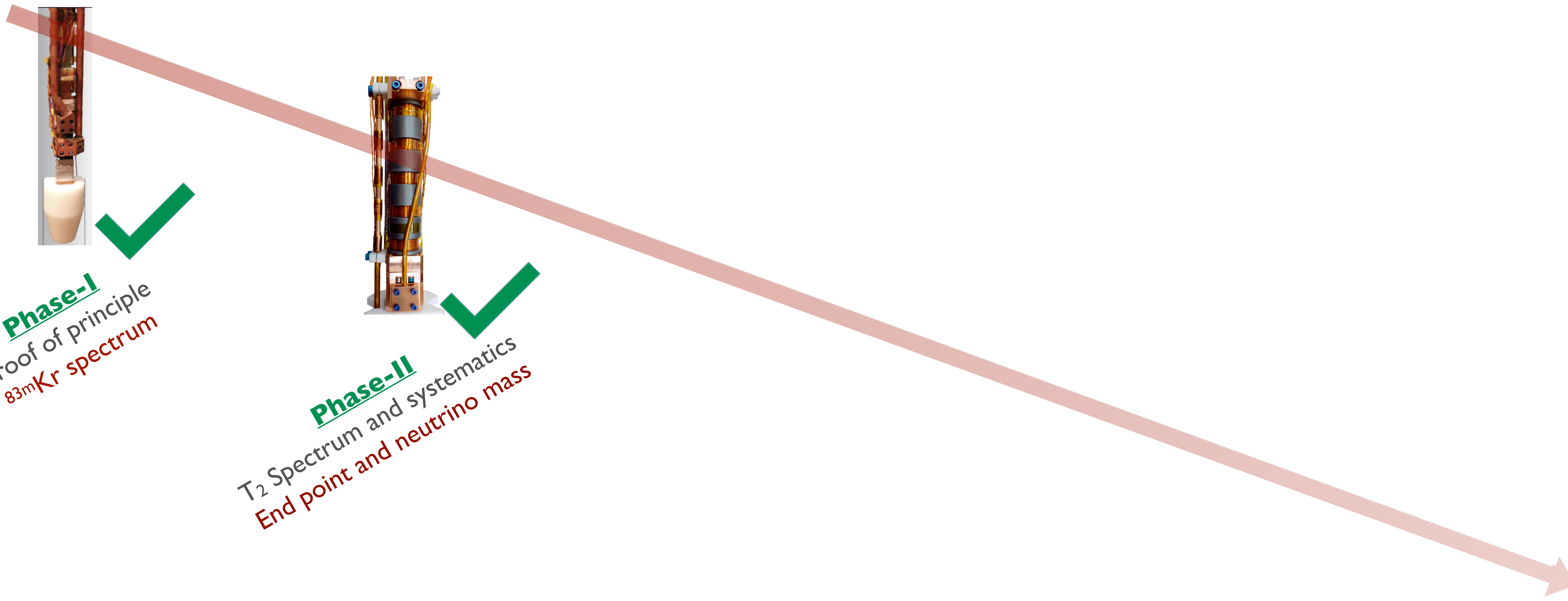



Project 8 Phased Approach

PROJECT 8



Phase-I
Proof of principle
 ^{83m}Kr spectrum



Phase-II
 T_2 Spectrum and systematics
End point and neutrino mass

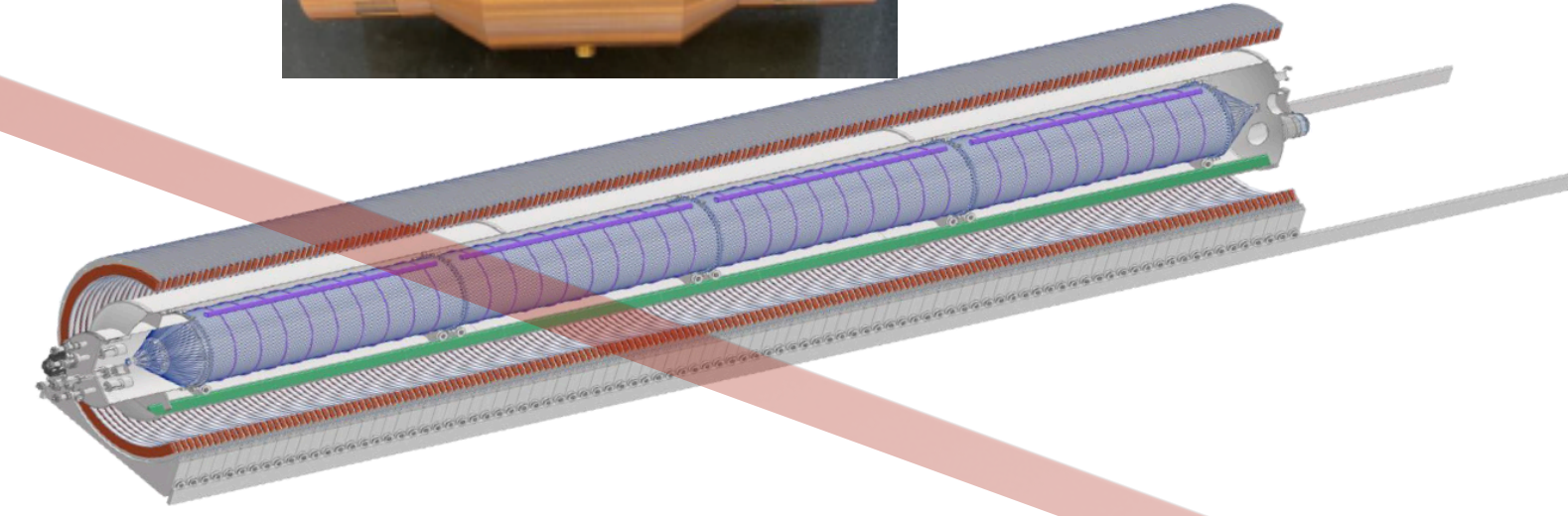
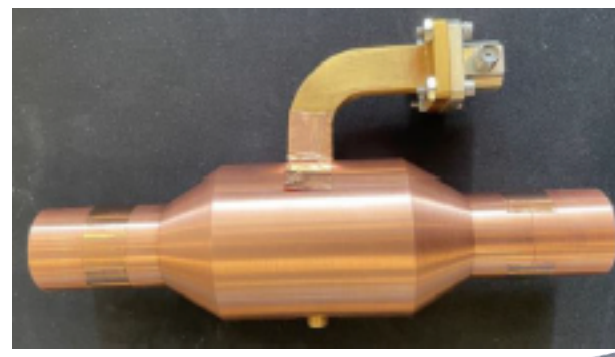

Phase-III
Scaling
Atomic tritium
 $\sim\text{eV}$ -scale mass limit



Project 8 Phased Approach

PROJECT 8



Phase-I
Proof of principle
 ^{83m}Kr spectrum



Phase-II
 T_2 Spectrum and systematics
End point and neutrino mass

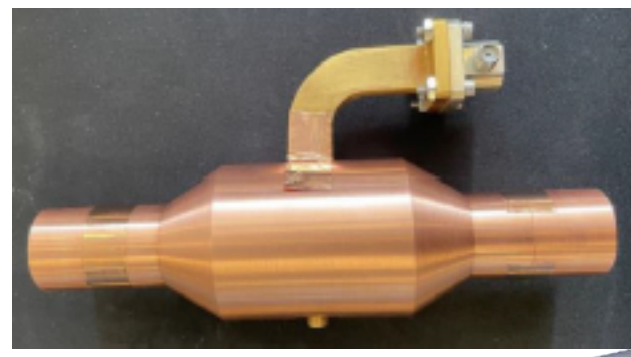

Phase-III
Scaling
Atomic tritium
 $\sim\text{eV}$ -scale mass limit

Ongoing



Project 8 Phased Approach

PROJECT 8



Phase-I
Proof of principle
 ^{83m}Kr spectrum



Phase-II
 T_2 Spectrum and systematics
End point and neutrino mass

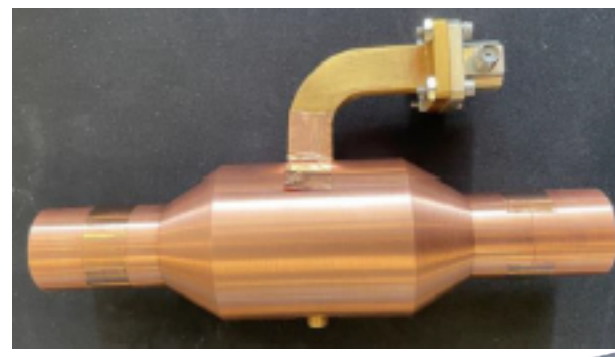

Ongoing
Phase-III
Scaling
Atomic tritium
 $\sim\text{eV-scale mass limit}$

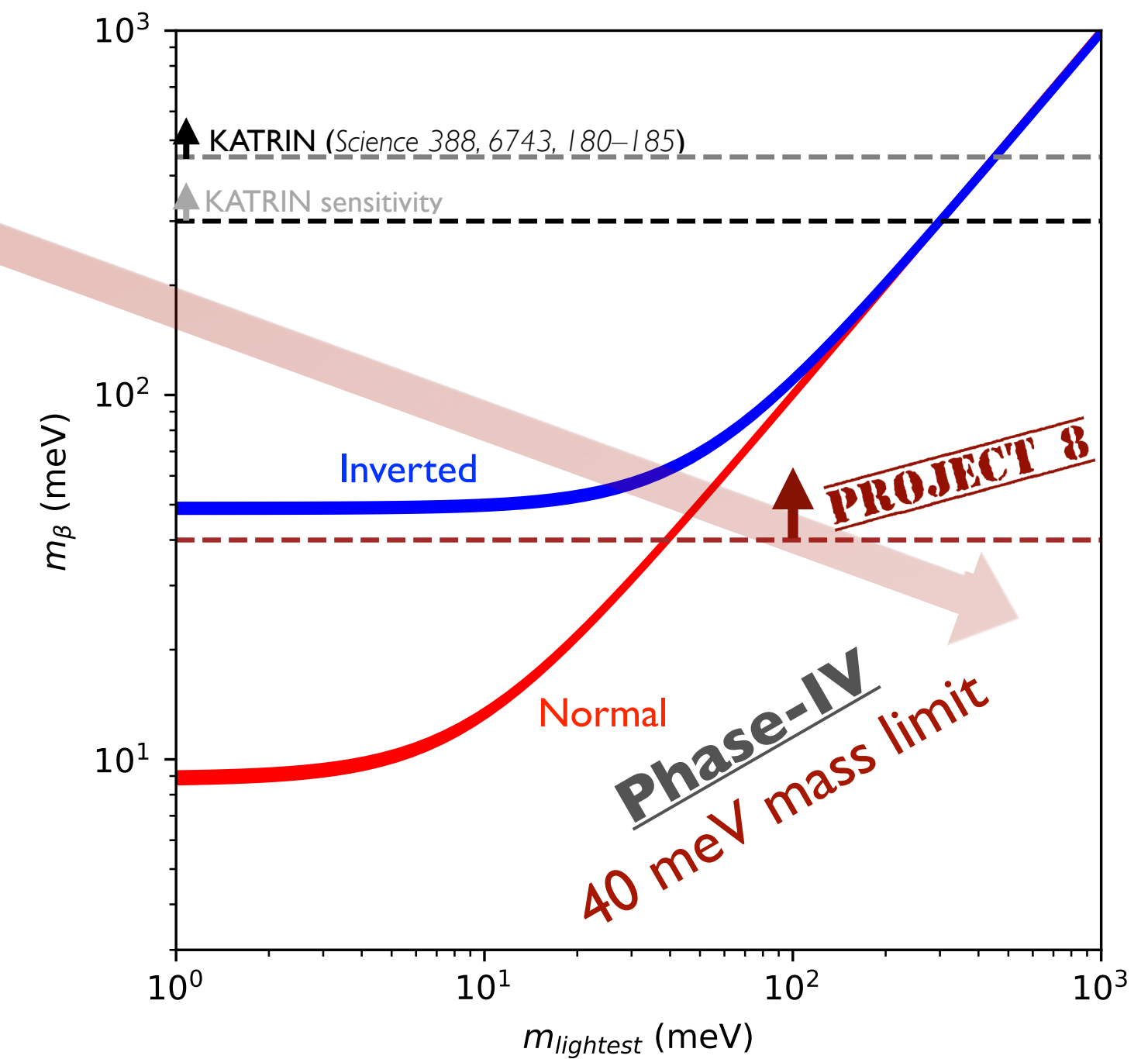



- First T_2 beta decay spectrum measurement using CRES
- Measured end point energy in agreement with prediction

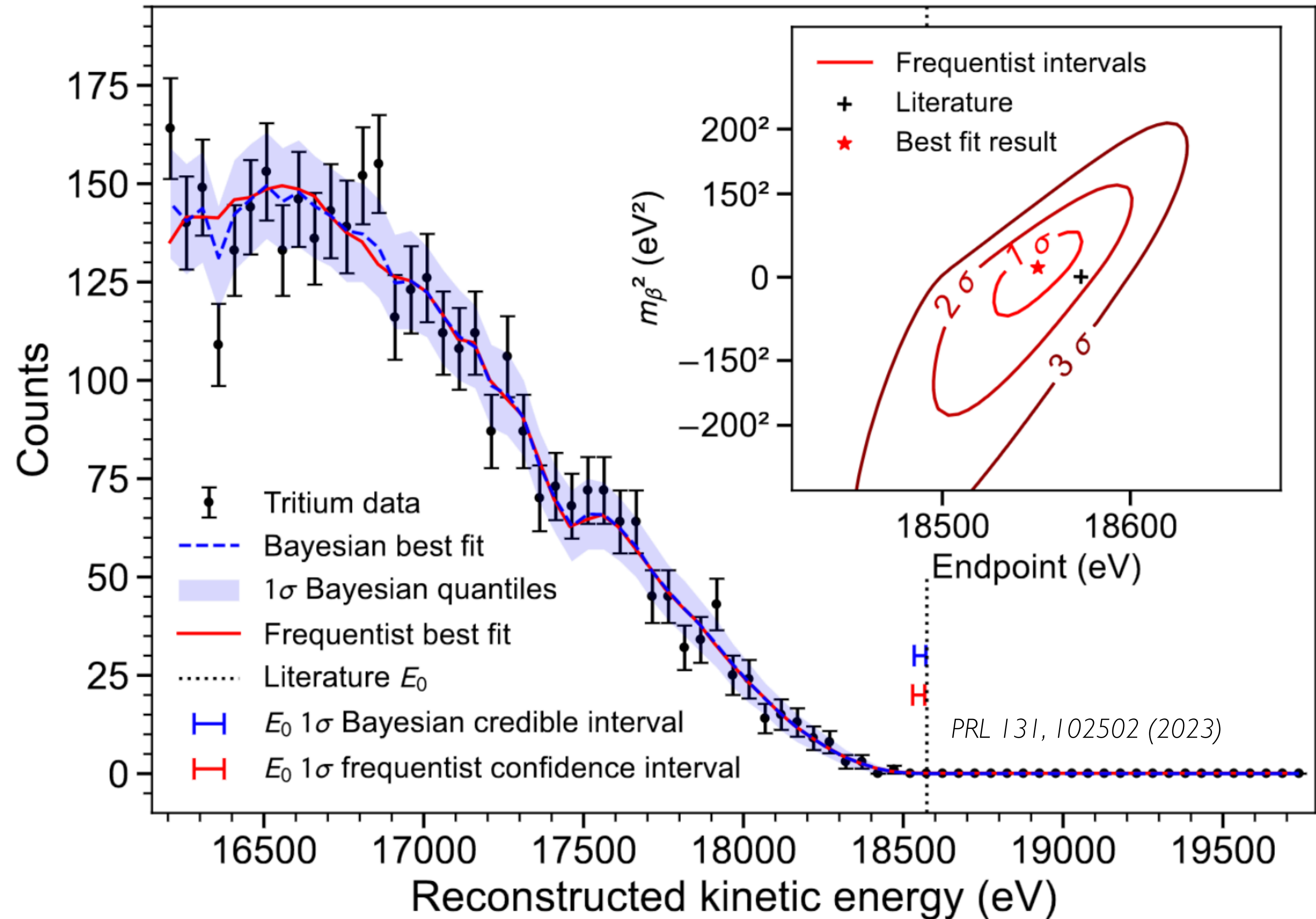



- First T_2 beta decay spectrum measurement using CRES
- Measured end point energy in agreement with prediction
- No events past end point => Background rate $\leq 3 \times 10^{-10} \text{ eV}^{-1} \text{ s}^{-1}$ (90 % CL)
- First limit on neutrino mass $\leq 155 \text{ eV}$ (90 % CI)

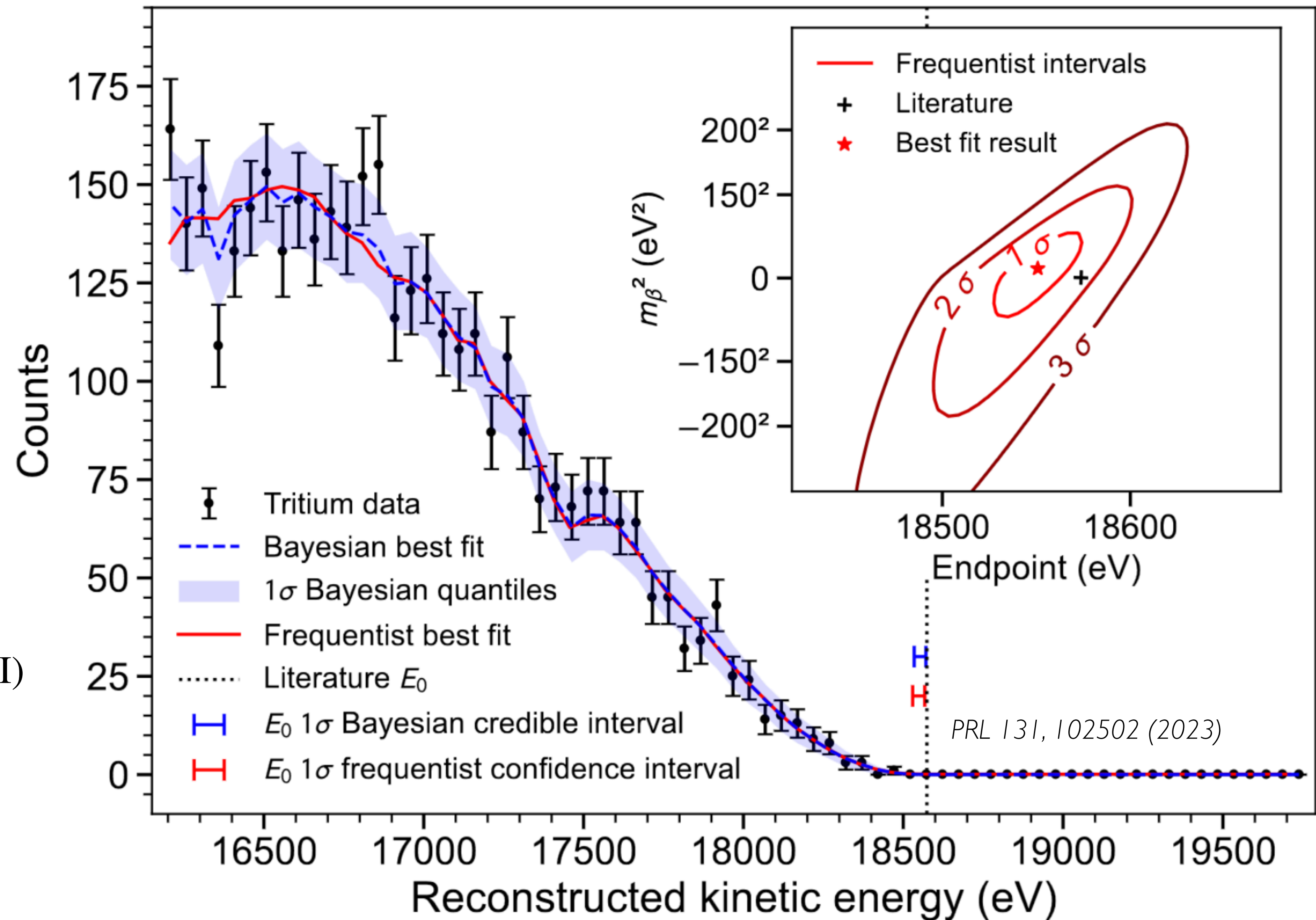



Phase II: First Neutrino Mass Limits with CRES

PROJECT 8

- First T_2 beta decay spectrum measurement using CRES
- Measured end point energy in agreement with prediction

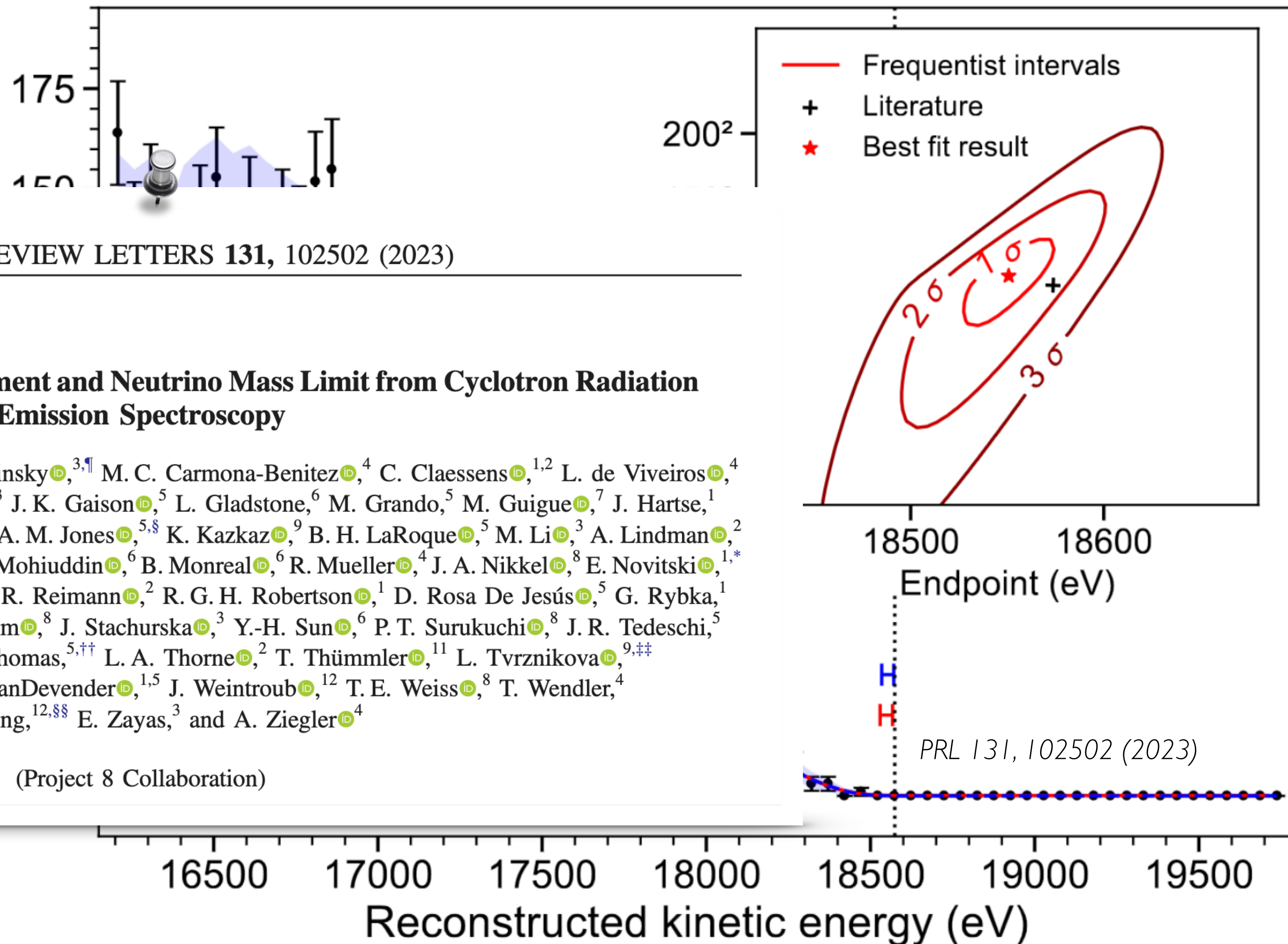

PHYSICAL REVIEW LETTERS 131, 102502 (2023)

Editors' Suggestion

Featured in Physics

Tritium Beta Spectrum Measurement and Neutrino Mass Limit from Cyclotron Radiation Emission Spectroscopy

A. Ashtari Esfahani^{1,||} S. Böser² N. Buzinsky^{3,¶} M. C. Carmona-Benitez⁴ C. Claessens^{1,2} L. de Viveiros⁴ P. J. Doe¹ M. Fertl² J. A. Formaggio³ J. K. Gaison⁵ L. Gladstone⁶ M. Grando⁵ M. Guigue⁷ J. Hartse¹ K. M. Heeger⁸ X. Huyan^{5,‡} J. Johnston³ A. M. Jones^{5,§} K. Kazkaz⁹ B. H. LaRoque⁵ M. Li³ A. Lindman² E. Machado¹ A. Marsteller¹ C. Matthé² R. Mohiuddin⁶ B. Monreal⁶ R. Mueller⁴ J. A. Nikkel⁸ E. Novitski^{1,*} N. S. Oblath⁵ J. I. Peña³ W. Pettus^{10,†} R. Reimann² R. G. H. Robertson¹ D. Rosa De Jesús⁵ G. Rybka¹ L. Saldaña⁸ M. Schram^{5,**} P. L. Slocum⁸ J. Stachurska³ Y.-H. Sun⁶ P. T. Surukuchi⁸ J. R. Tedeschi⁵ A. B. Telles⁸ F. Thomas² M. Thomas^{5,††} L. A. Thorne² T. Thümmeler¹¹ L. Tvrznikova^{9,‡‡} W. Van De Pontseele³ B. A. VanDevender^{1,5} J. Weintraub¹² T. E. Weiss⁸ T. Wendler⁴ A. Young^{12,§§} E. Zayas³ and A. Ziegler⁴

(Project 8 Collaboration)

- No events past end $\leq 3 \times 10^{-10} \text{eV}^{-1}$
- First limit on neutrino



$$\sigma_{m_{\beta}^2} = \frac{2}{3} \sqrt{\frac{1}{rt} \left[\Delta E + \frac{b}{r\Delta E} \right] + 4 \sum_i \sigma_i^2 \cdot \delta\sigma_i^2}$$



- Project 8 Phase-II measurement limited by statistics => **Increase the volume**

$$\sigma_{m_{\beta}^2} = \frac{2}{3} \sqrt{\frac{1}{rt} \left[\Delta E + \frac{b}{r\Delta E} \right] + 4 \sum_i \sigma_i^2 \cdot \delta\sigma_i^2}$$



- Project 8 Phase-II measurement limited by statistics => **Increase the volume**
- Energy resolution is the dominant systematic => **Improve energy resolution**

$$\sigma_{m_{\beta}^2} = \frac{2}{3} \sqrt{\frac{1}{rt} \left[\Delta E + \frac{b}{r\Delta E} \right] + 4 \sum_i \sigma_i^2 \cdot \delta\sigma_i^2}$$



Reaching Inverted Ordering with Project 8

PROJECT 8

- Project 8 Phase-II measurement limited by statistics => **Increase the volume**
- Energy resolution is the dominant systematic => **Improve energy resolution**
- Molecular tritium final states contribute to energy broadening => **Use atomic tritium**

$$\sigma_{m_{\beta}^2} = \frac{2}{3} \sqrt{\frac{1}{rt} \left[\Delta E + \frac{b}{r\Delta E} \right] + 4 \sum_i \sigma_i^2 \cdot \delta\sigma_i^2}$$

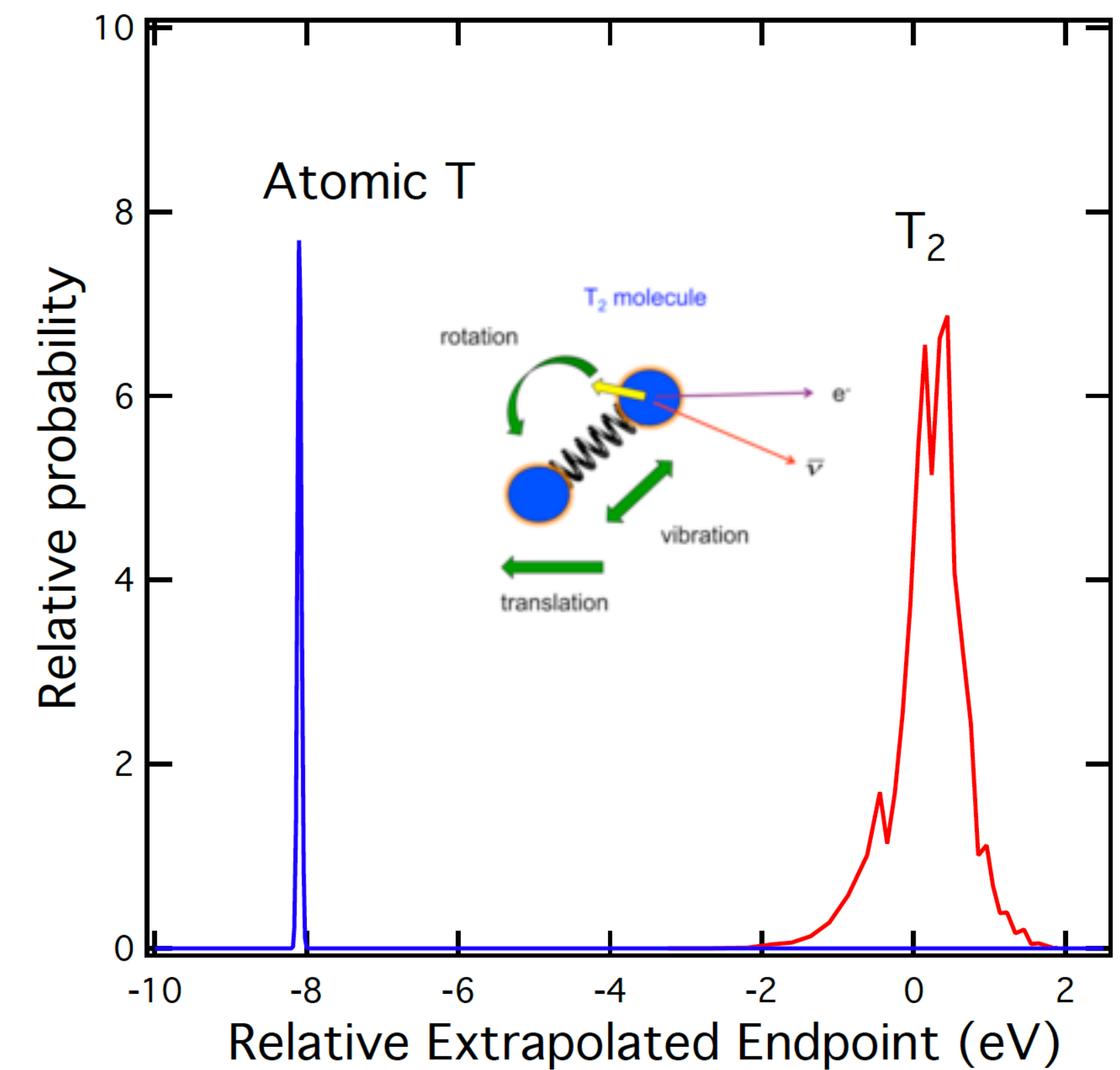



Reaching Inverted Ordering with Project 8

PROJECT 8

- Project 8 Phase-II measurement limited by statistics => **Increase the volume**
- Energy resolution is the dominant systematic => **Improve energy resolution**
- Molecular tritium final states contribute to energy broadening => **Use atomic tritium**
- Maintain **low backgrounds** by maintaining high SNR

$$\sigma_{m_\beta^2} = \frac{2}{3} \sqrt{\frac{1}{rt} \left[\Delta E + \frac{b}{r\Delta E} \right]^2 + 4 \sum_i \sigma_i^2 \cdot \delta\sigma_i^2}$$

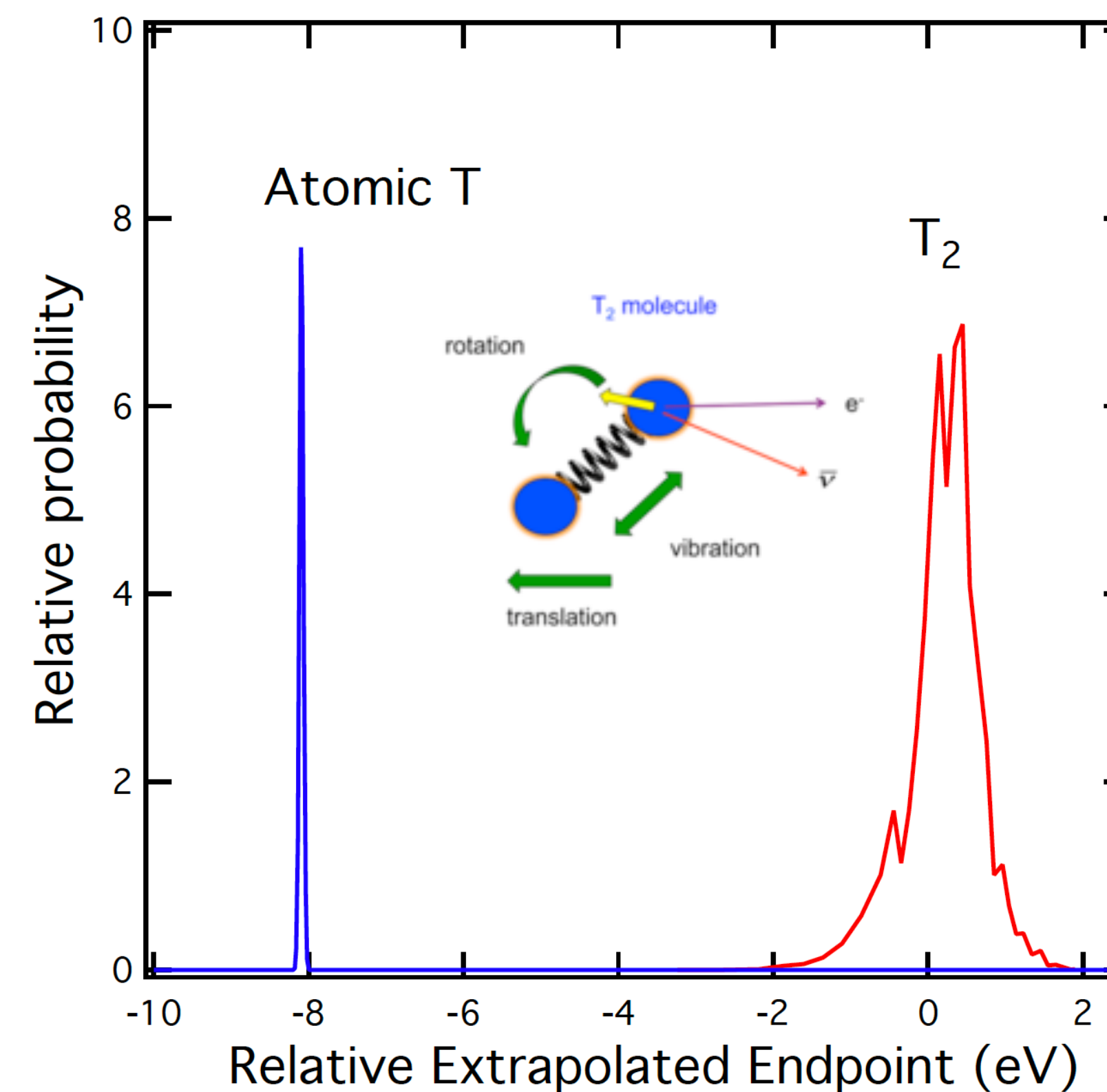



- Project 8 Phase-II measurement limited by statistics => **Increase the volume**
- Energy resolution is the dominant systematic => **Improve energy resolution**
- Molecular tritium final states contribute to energy broadening => **Use atomic tritium**
- Maintain **low backgrounds** by maintaining high SNR

$$\sigma_{m_{\beta}^2} = \frac{2}{3} \sqrt{\frac{1}{rt} \left[\Delta E + \frac{b}{r\Delta E} \right] + 4 \sum_i \sigma_i^2 \cdot \delta\sigma_i^2}$$

Project 8 is pursuing two major R&D efforts:

1. **Atomic tritium** source development
2. **Large, highly-resolved** CRES detector

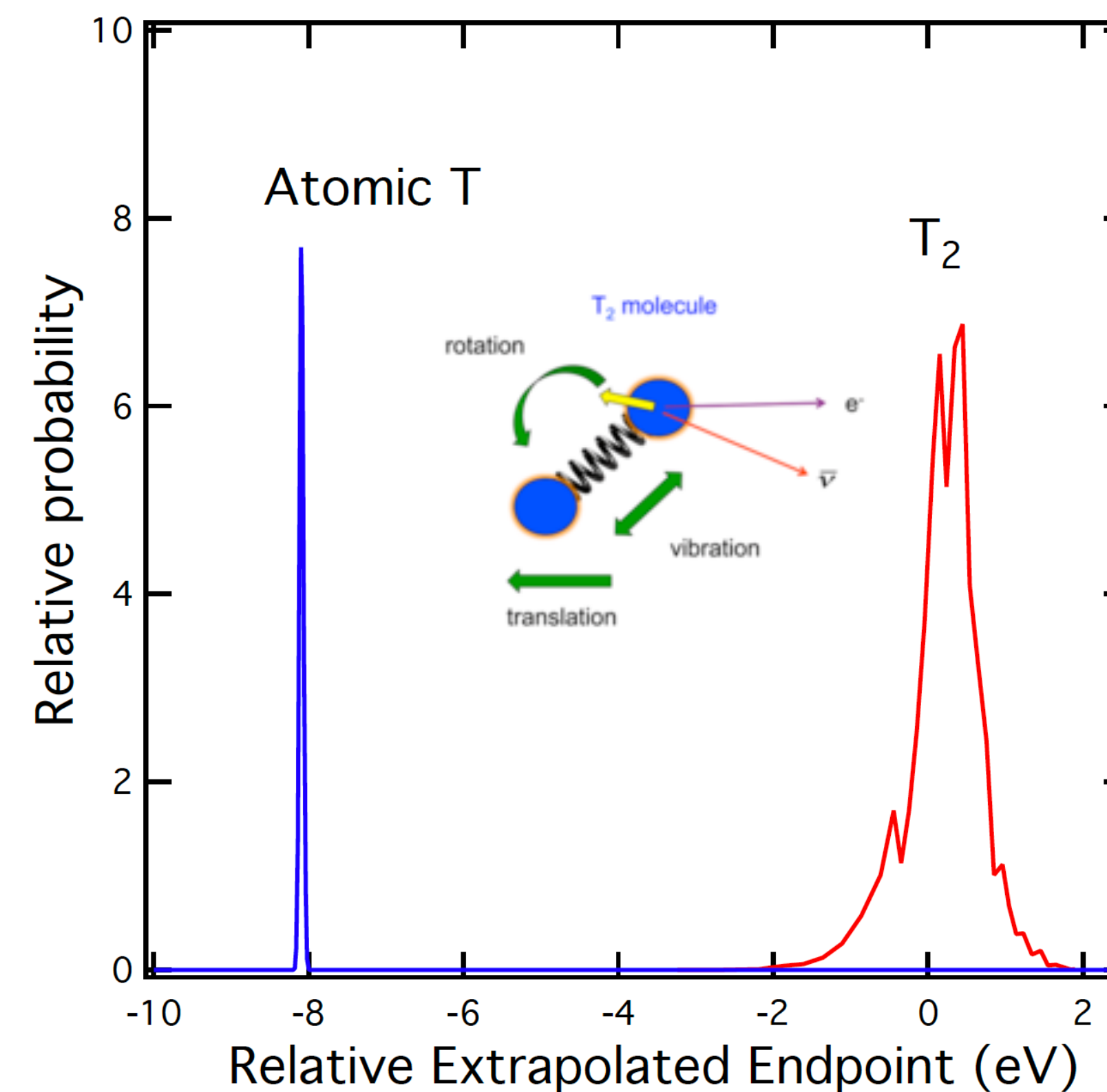



Atomic Tritium R&D

PROJECT 8

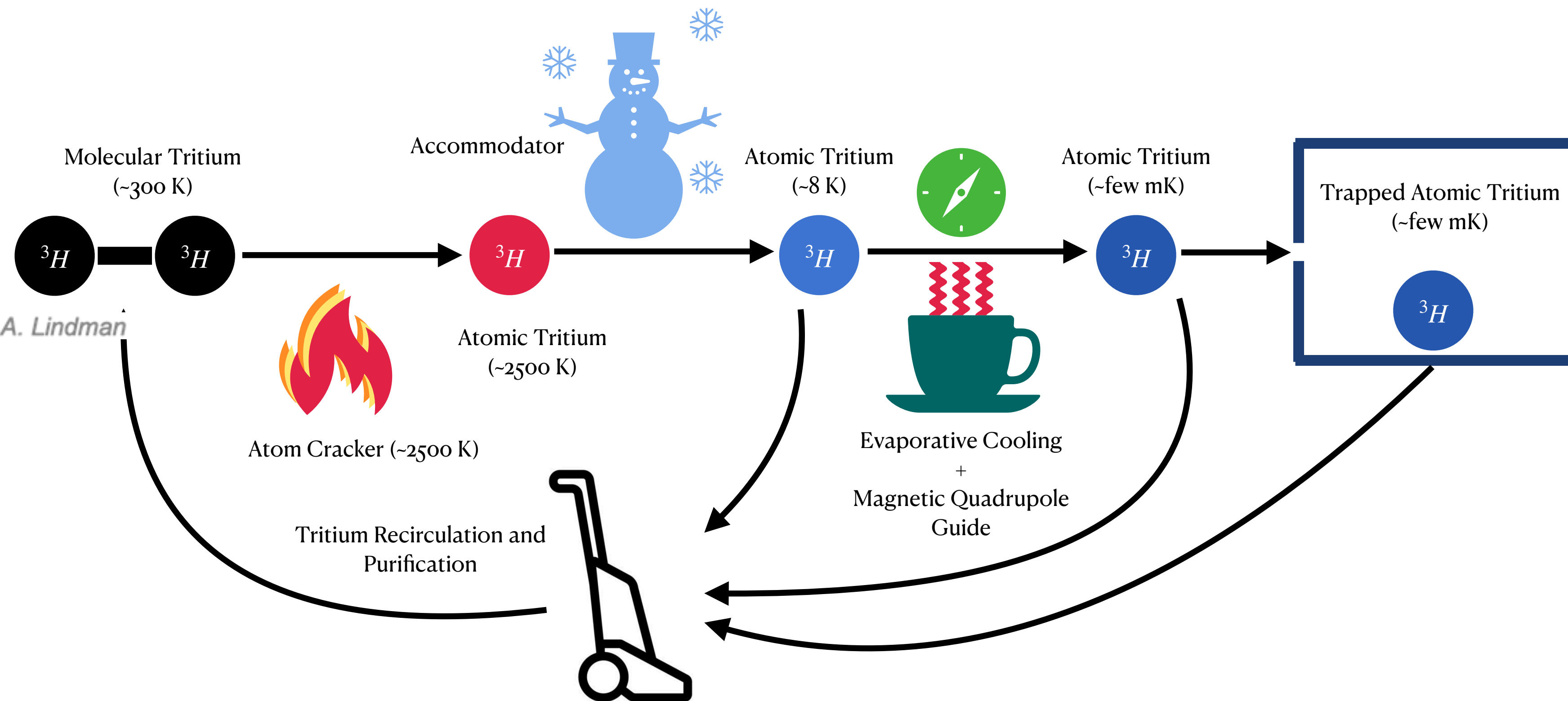



Atomic Tritium R&D

PROJECT 8

I. Production: High flux of dissociated tritium atoms

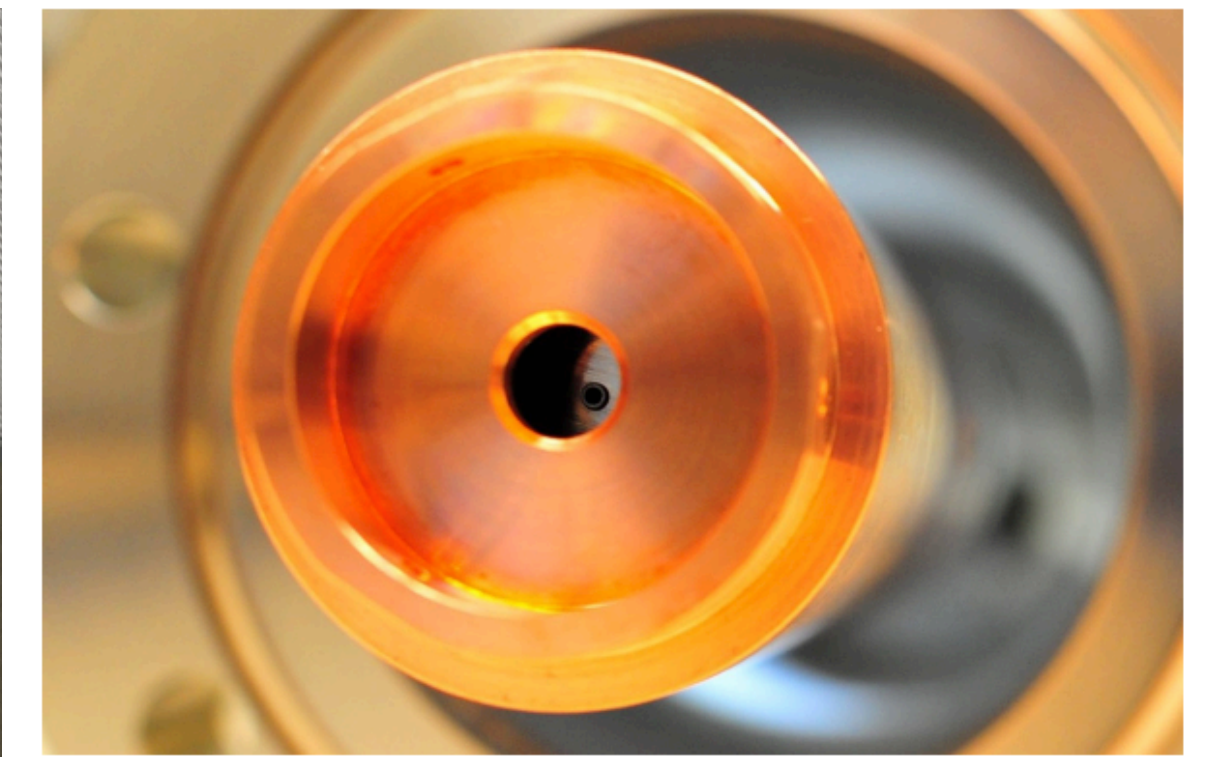

Dissociate high flux of T₂ to T

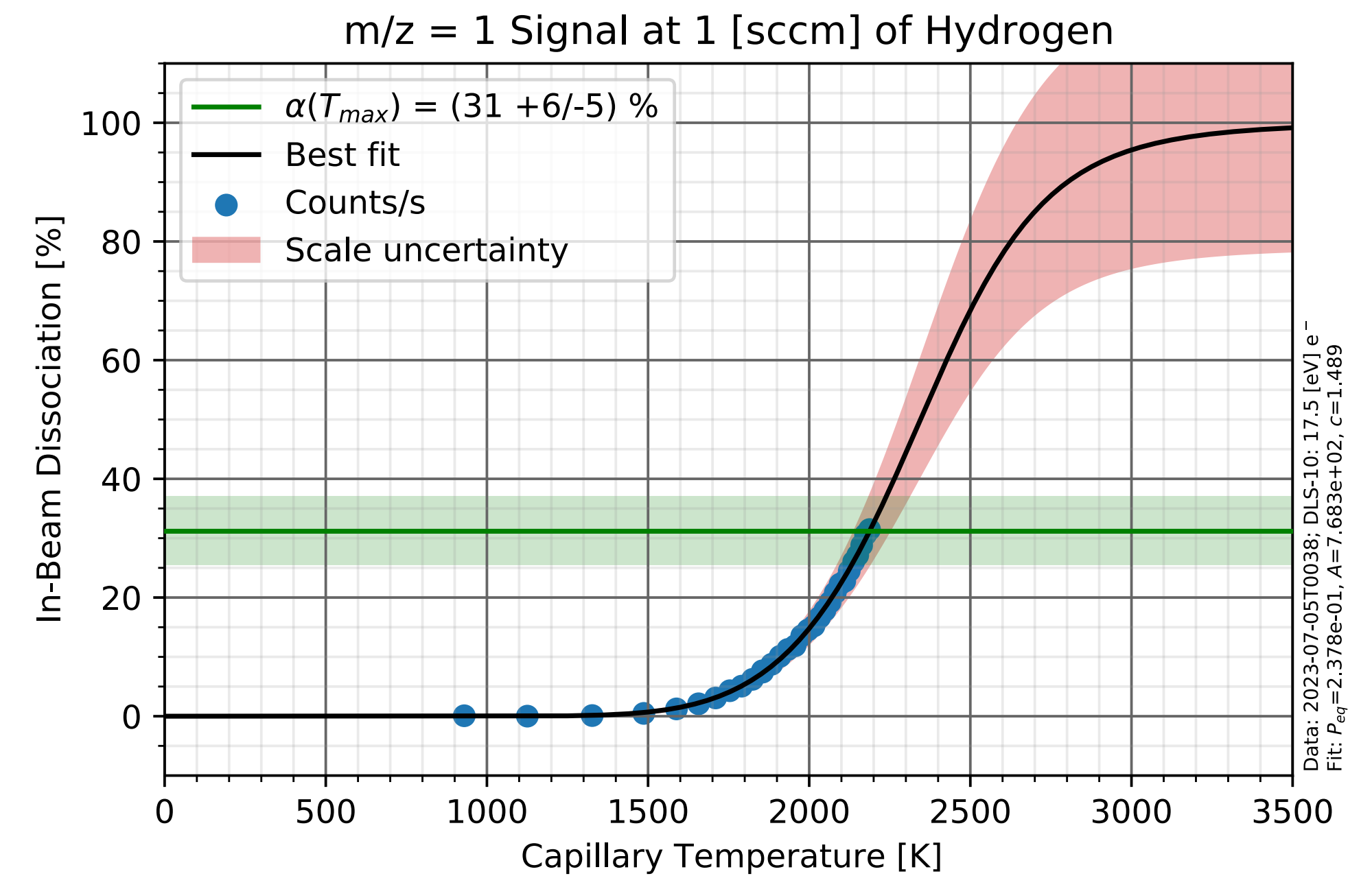
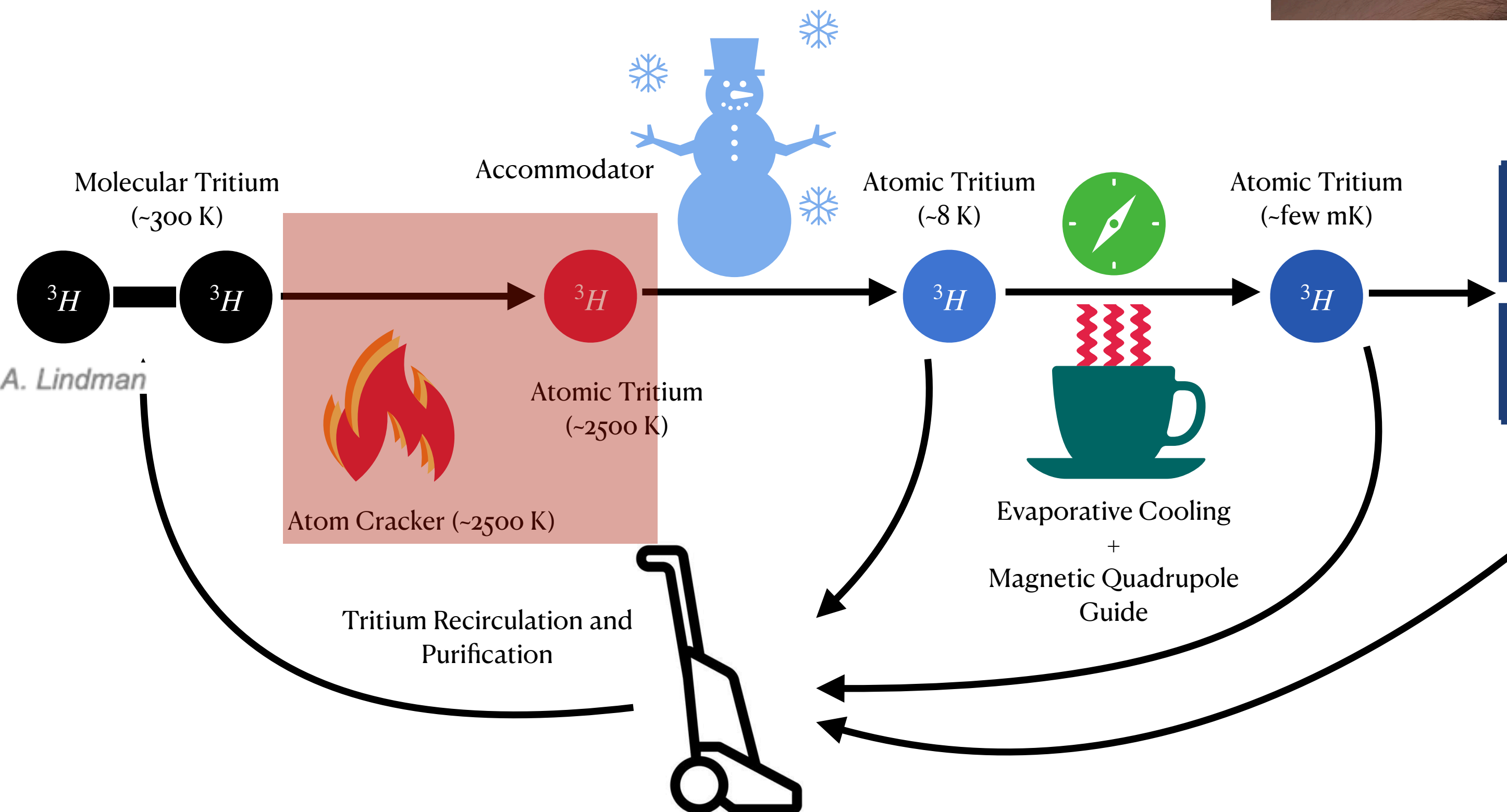

Demonstration of dissociation of H₂



Atomic Tritium R&D

PROJECT 8

1. Production: High flux of dissociated tritium atoms
2. Cooling: Low-loss cooling to ~mK temperatures

Cooling by bouncing off of cold surfaces

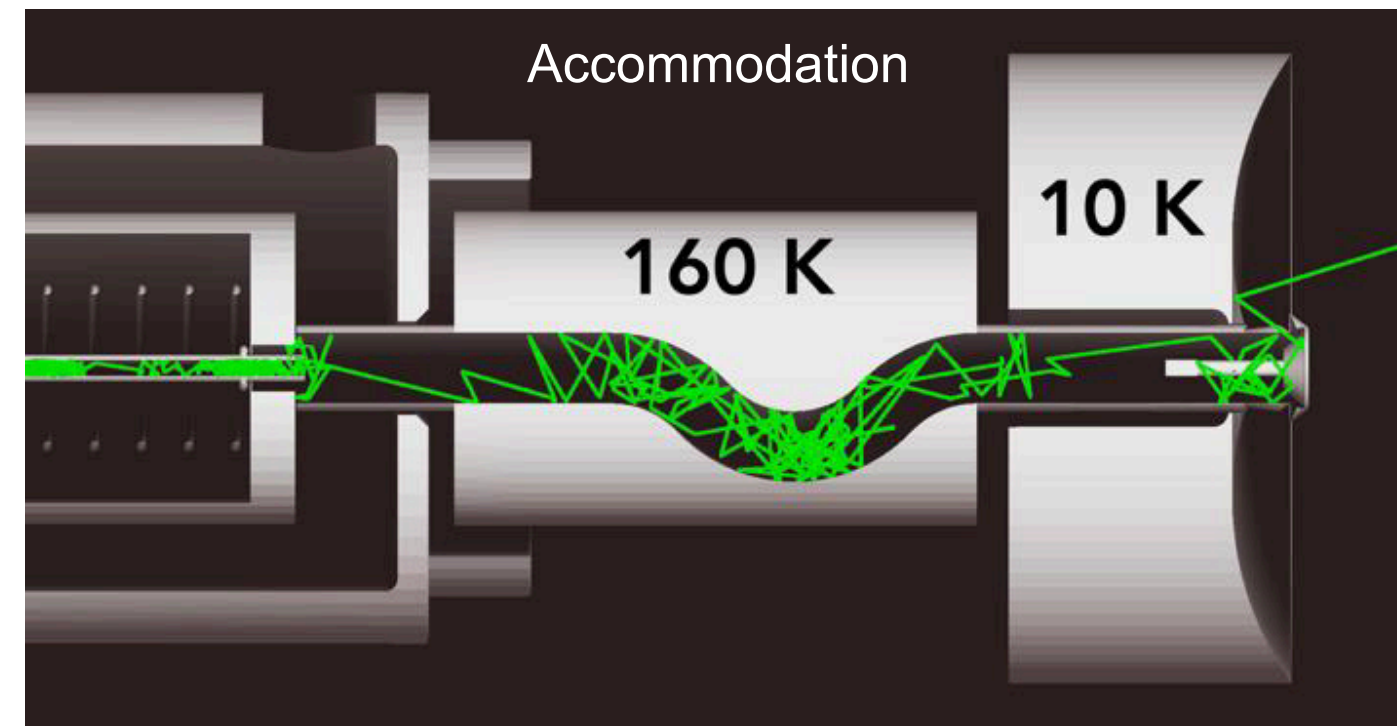

Letting the hot atoms evaporate by adiabatically dropping the magnetic fields

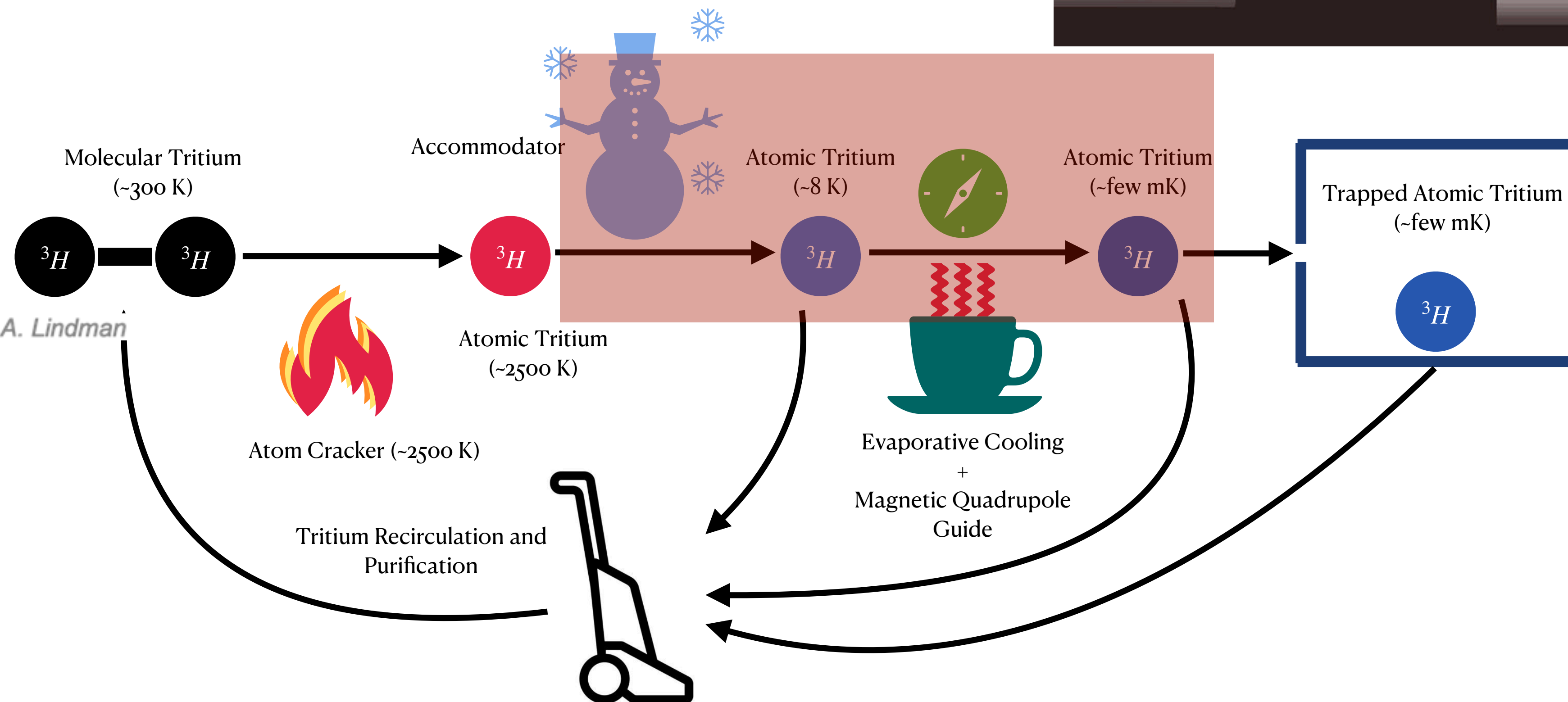
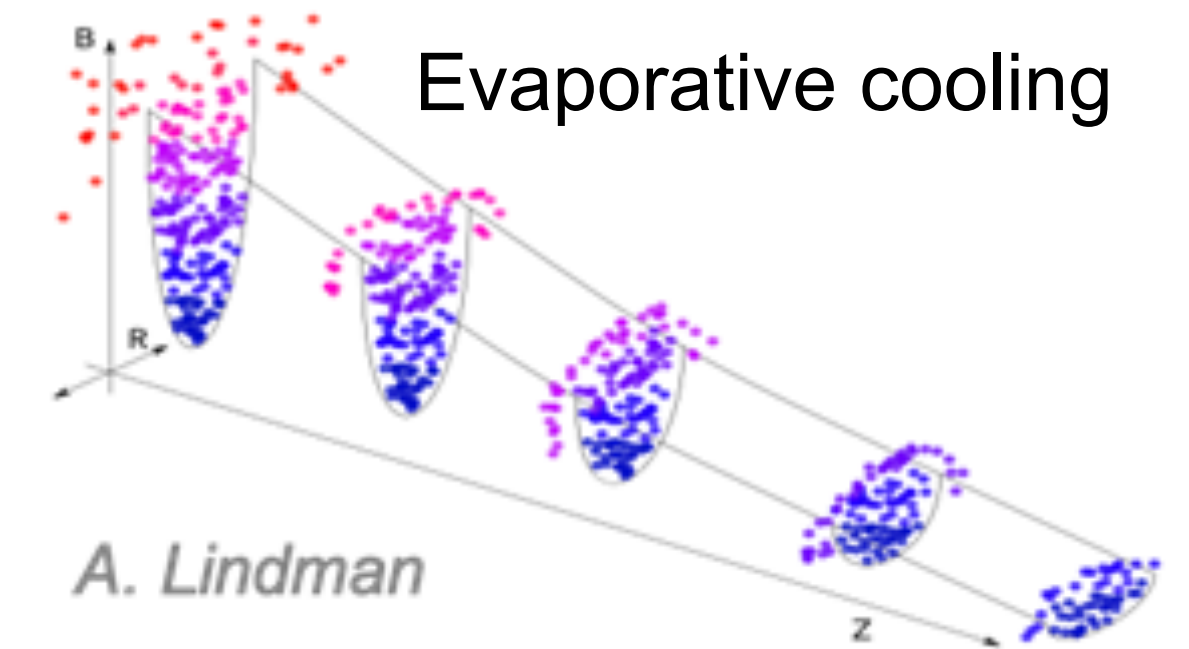

Slowing beams by transverse perturbations

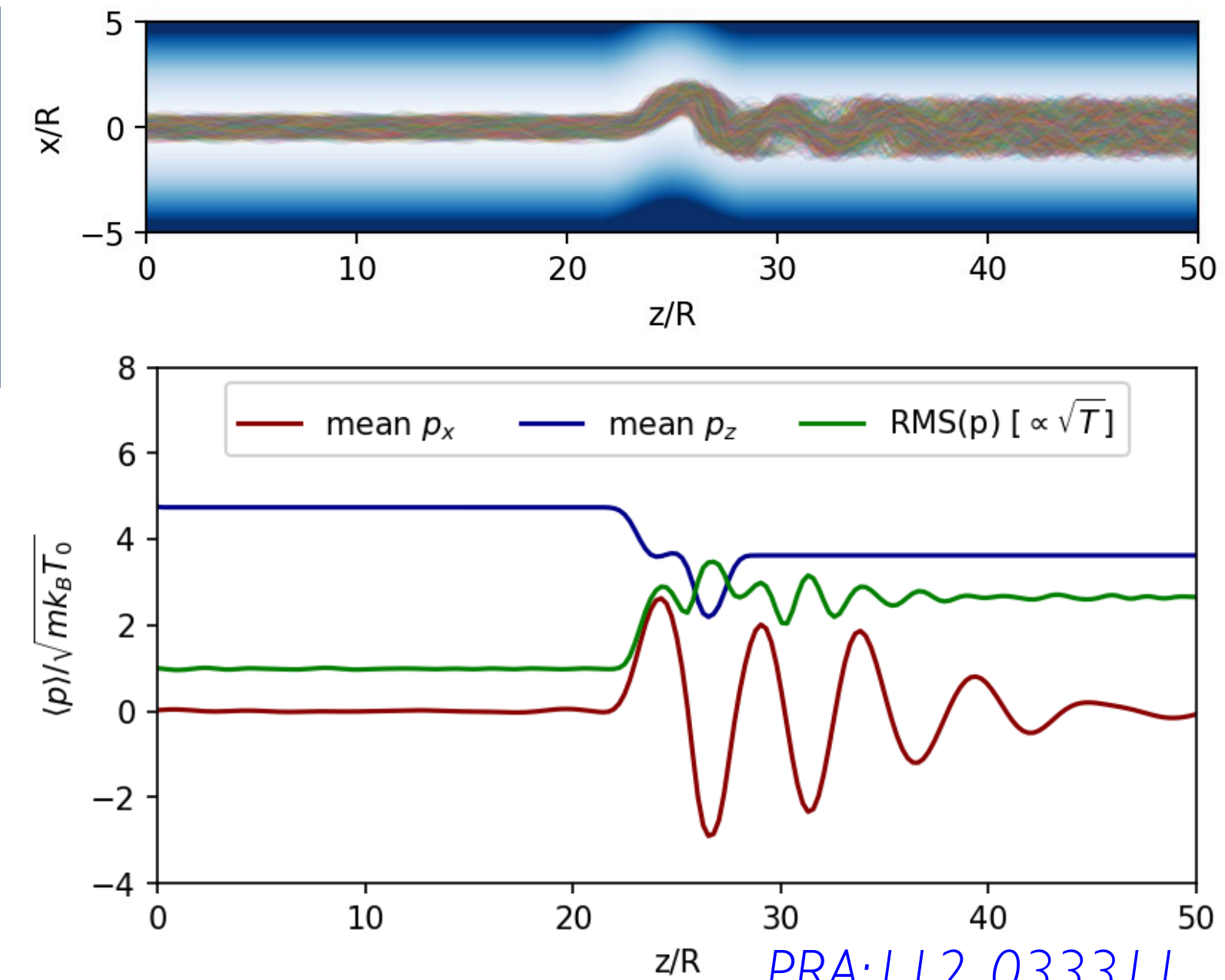



Atomic Tritium R&D

PROJECT 8

1. Production: High flux of dissociated tritium atoms
2. Cooling: Low-loss cooling to ~mK temperatures
3. Trapping: Sustained long-term trapping with low losses

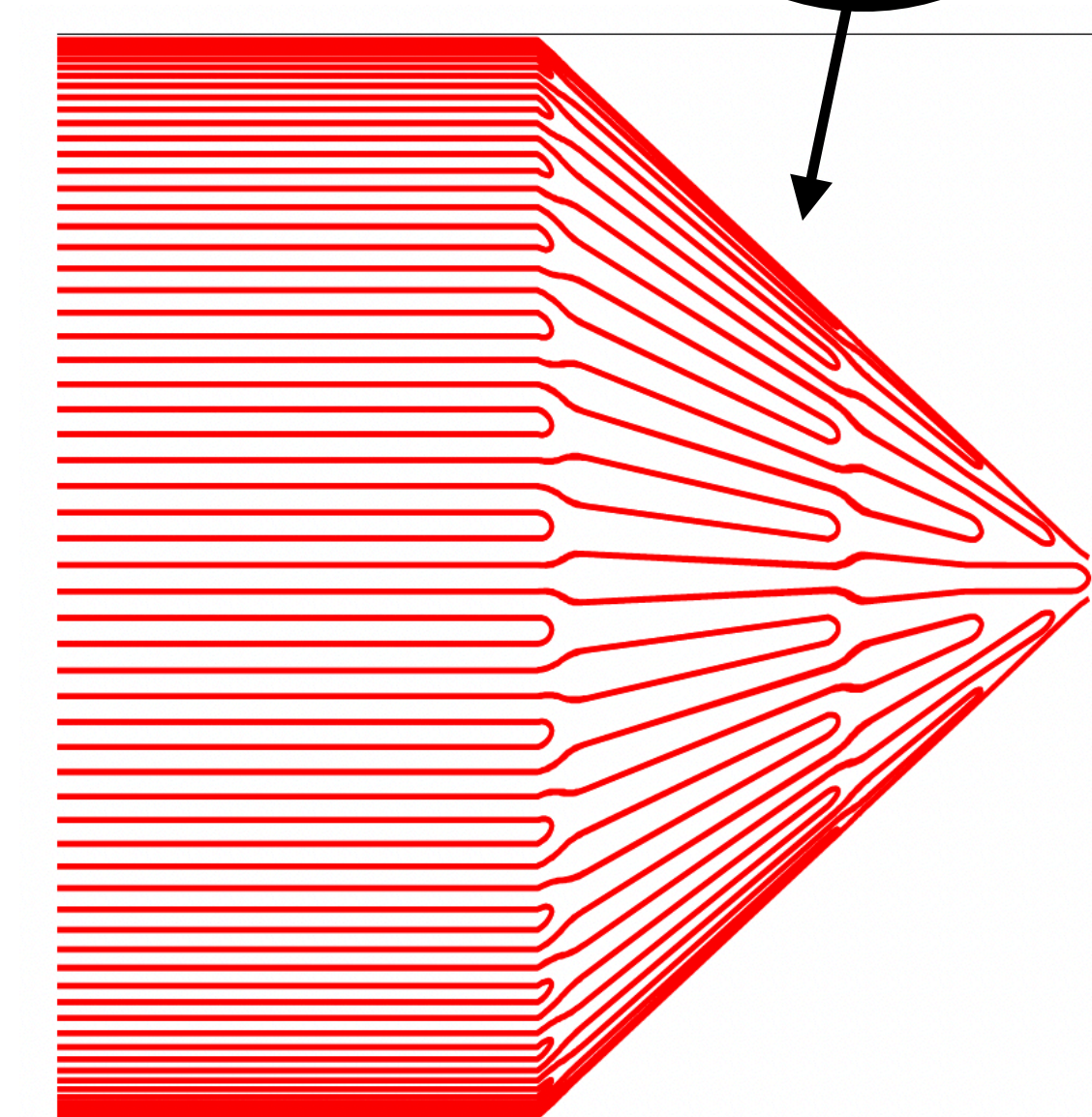
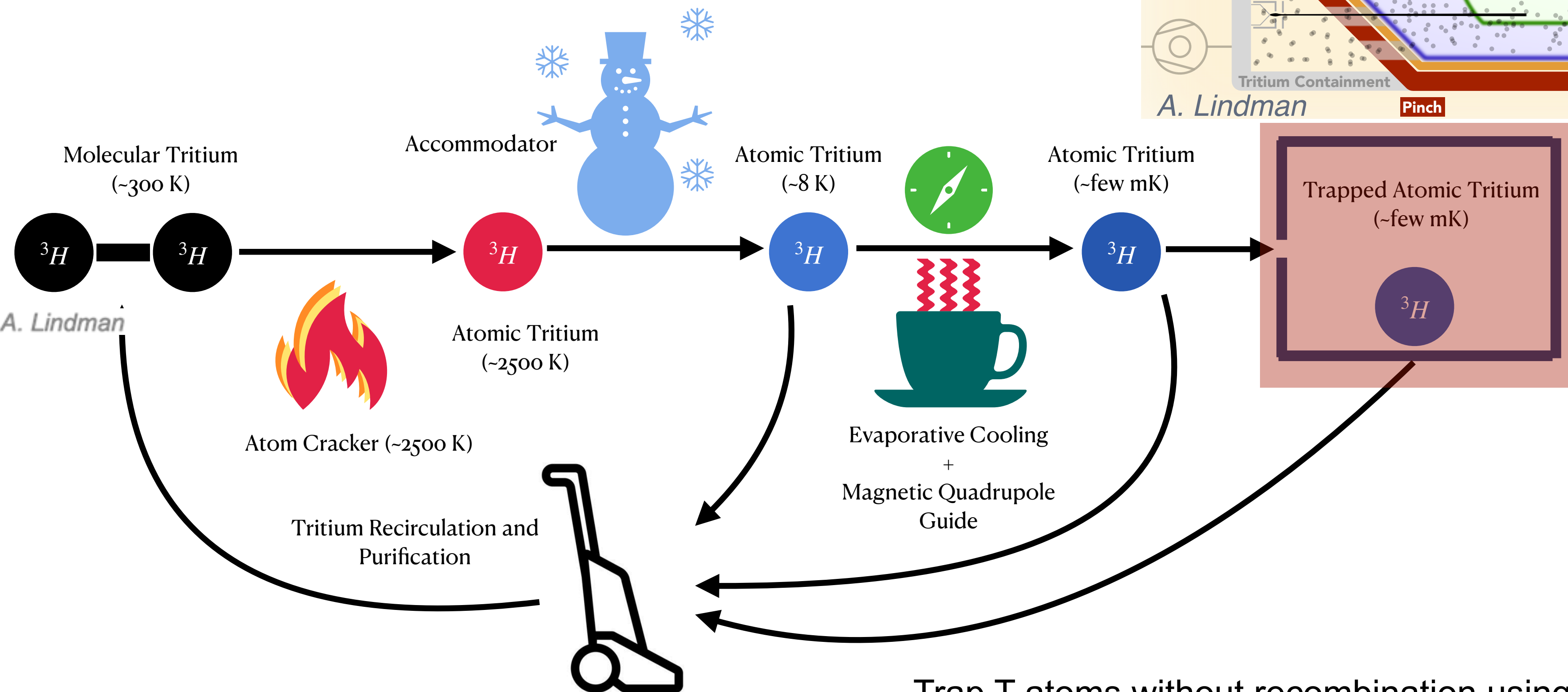
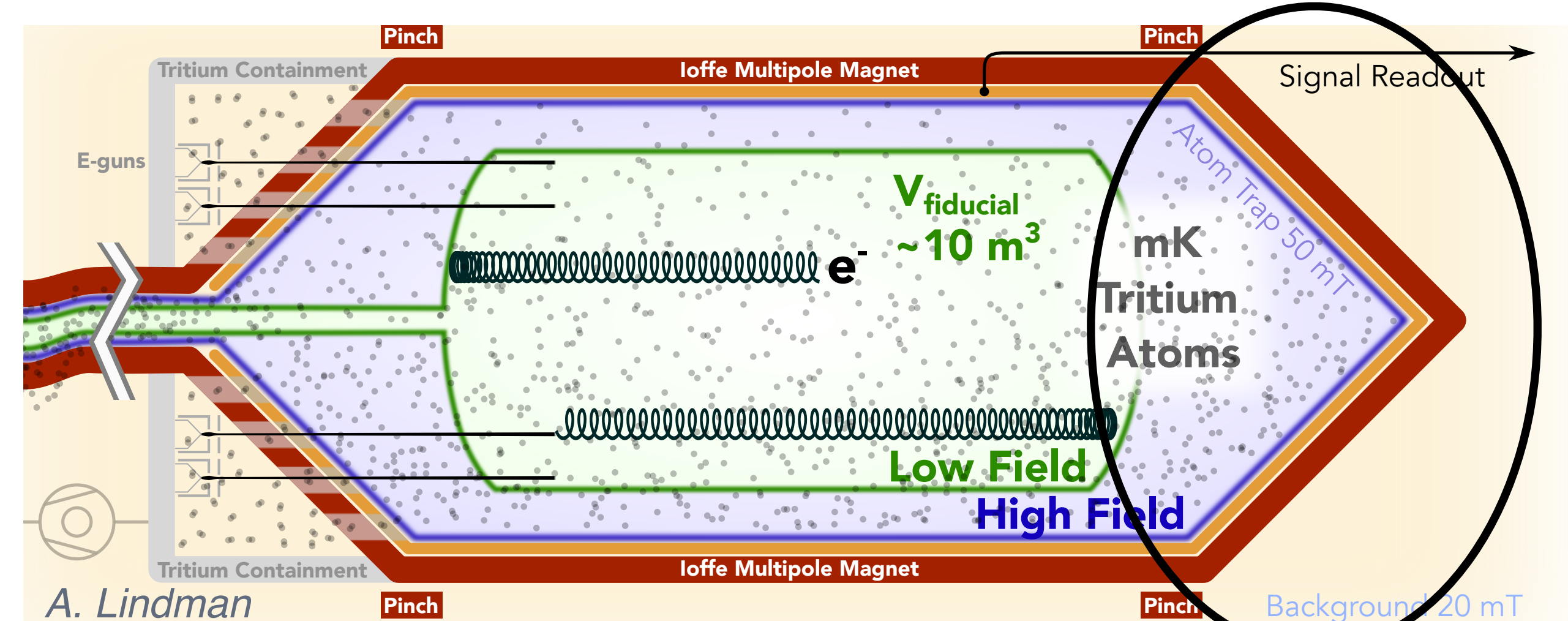

Trap T atoms without recombination using a high-order multipole trap with steep walls



Atomic Tritium R&D

PROJECT 8

1. Production: High flux of dissociated tritium atoms
2. Cooling: Low-loss cooling to ~mK temperatures
3. Trapping: Sustained long-term trapping with low losses

High-Flux Atomic Source for the Project 8 Neutrino Mass Experiment
W. Pettus, E. Novitski, H. Robertson, B. Foust, M. Wynne, J. Oueslati

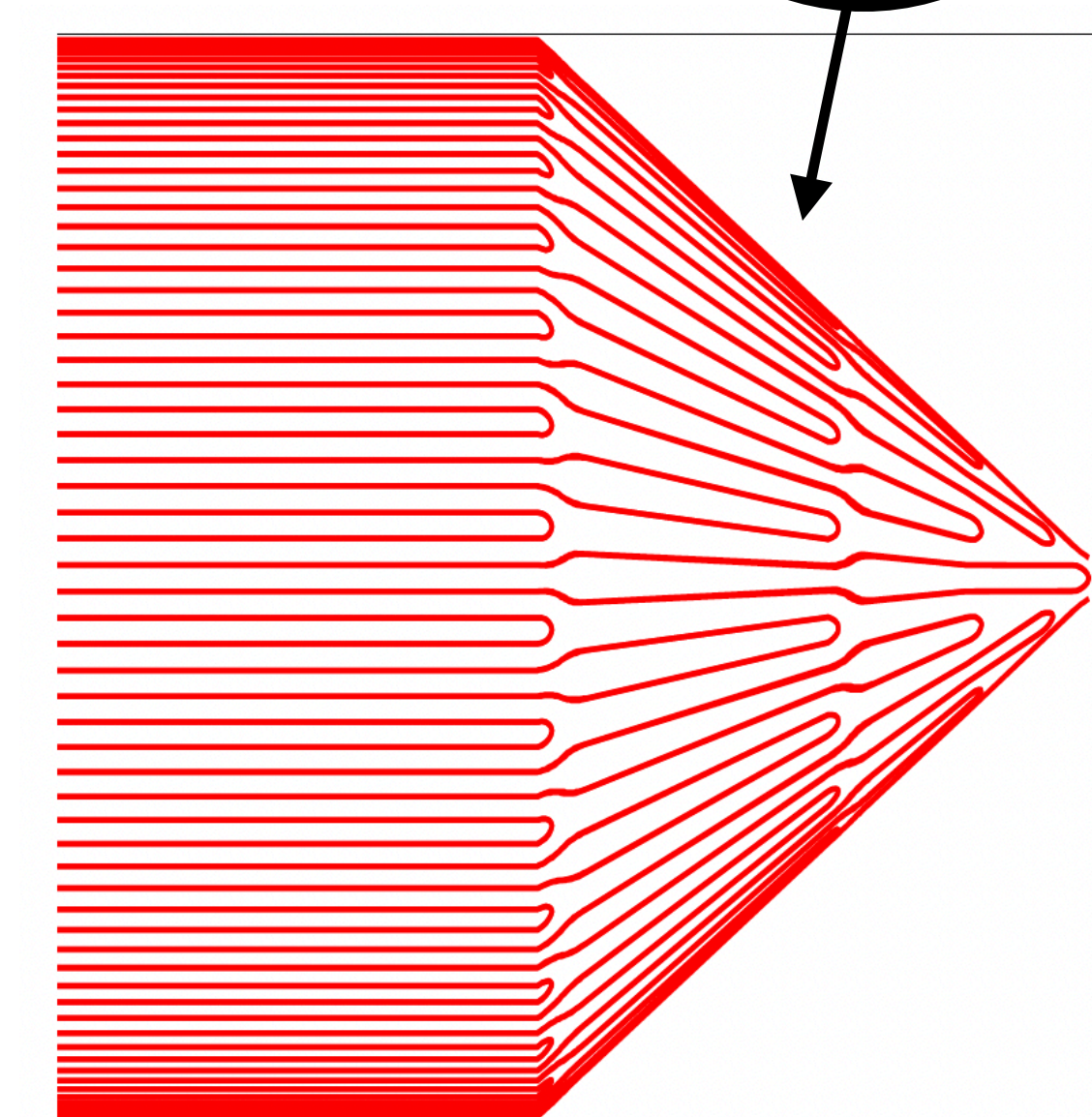
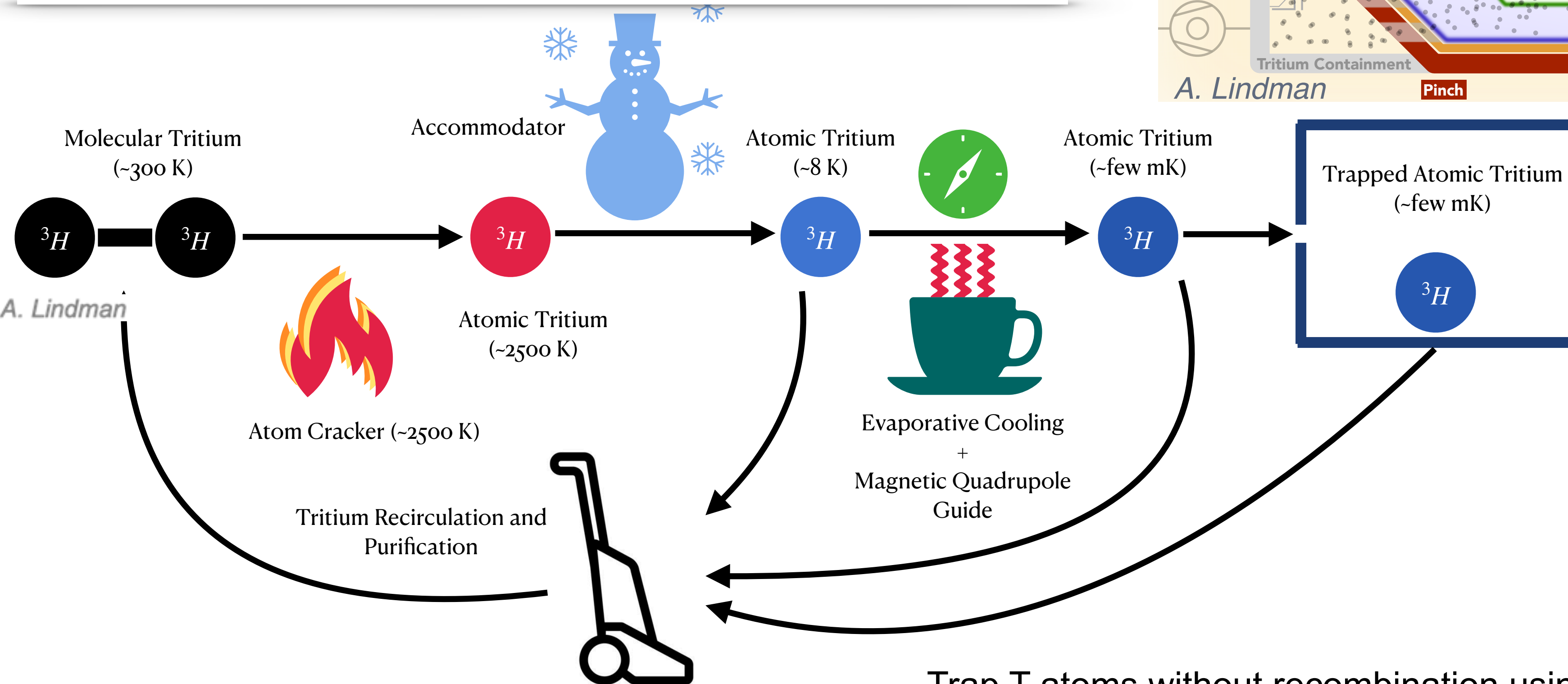
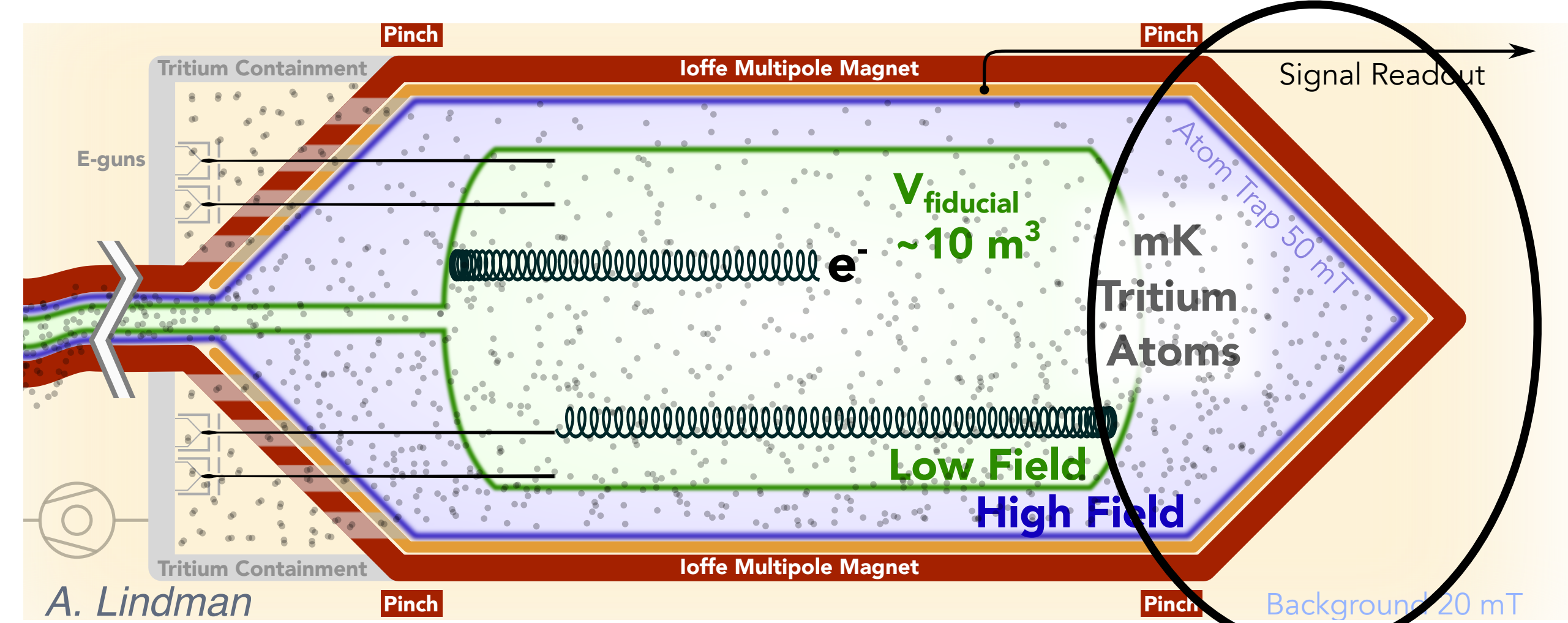

Trap T atoms without recombination using a high-order multipole trap with steep walls



Phase-II

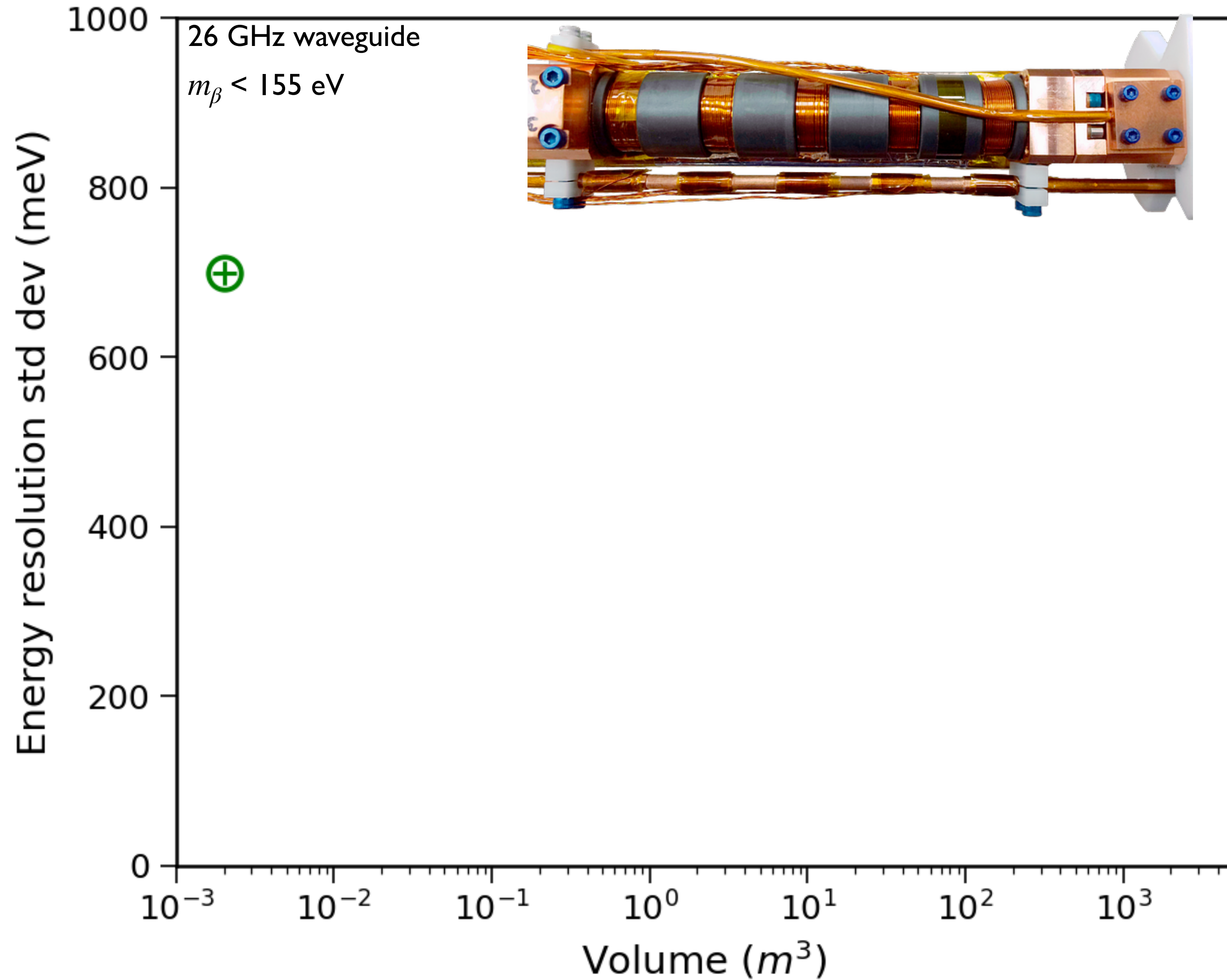



Phase-II

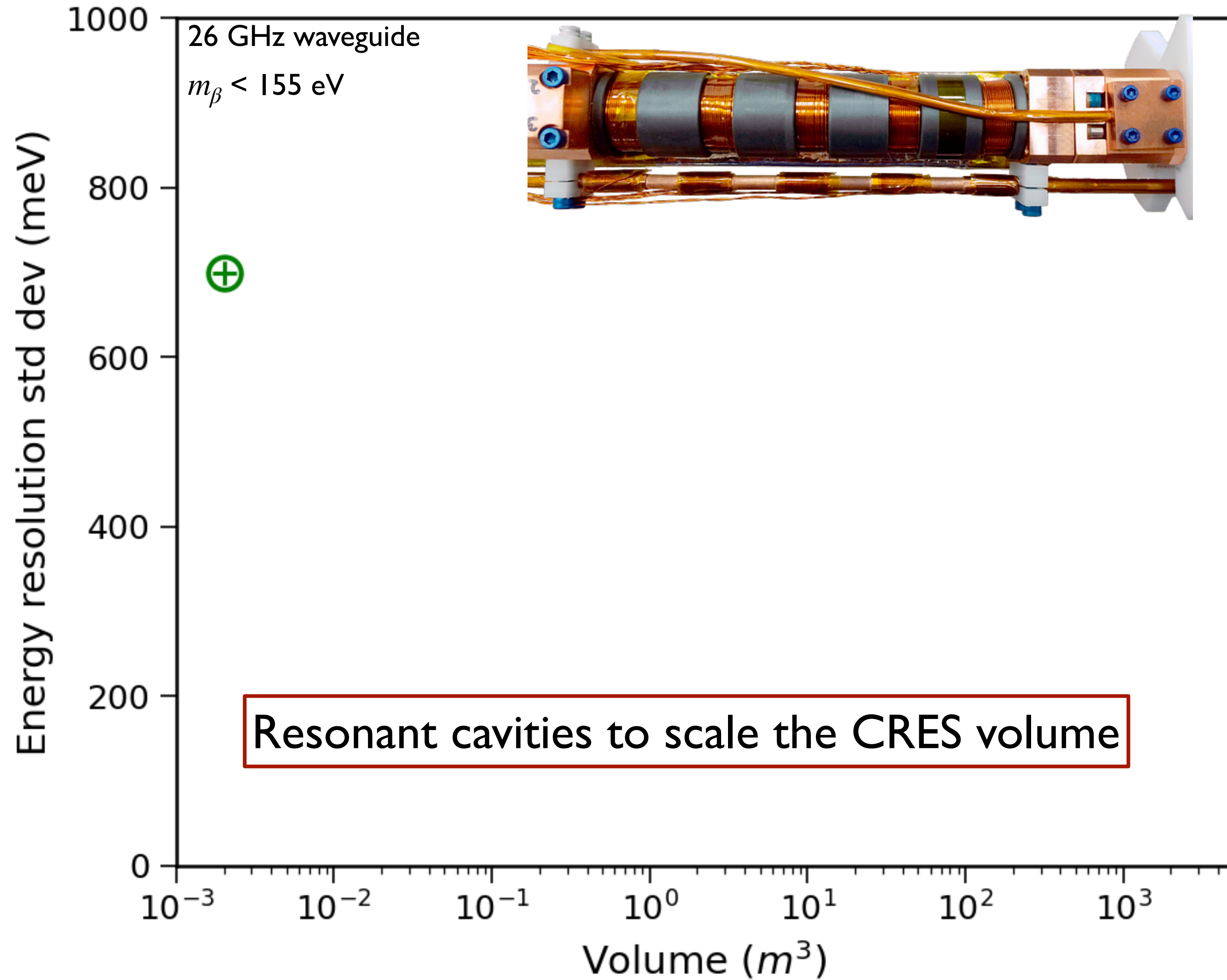



Phase-III

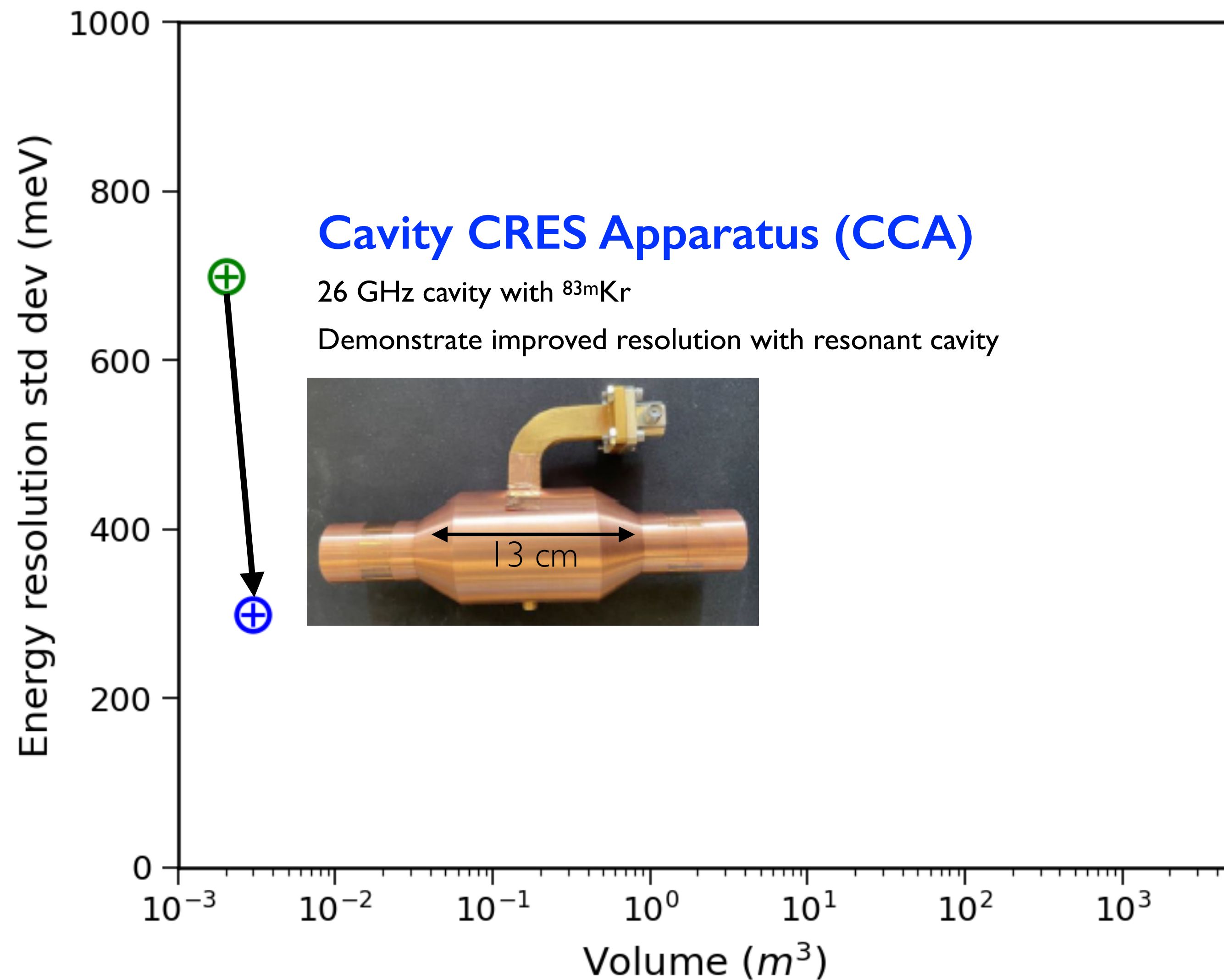



Phase-III

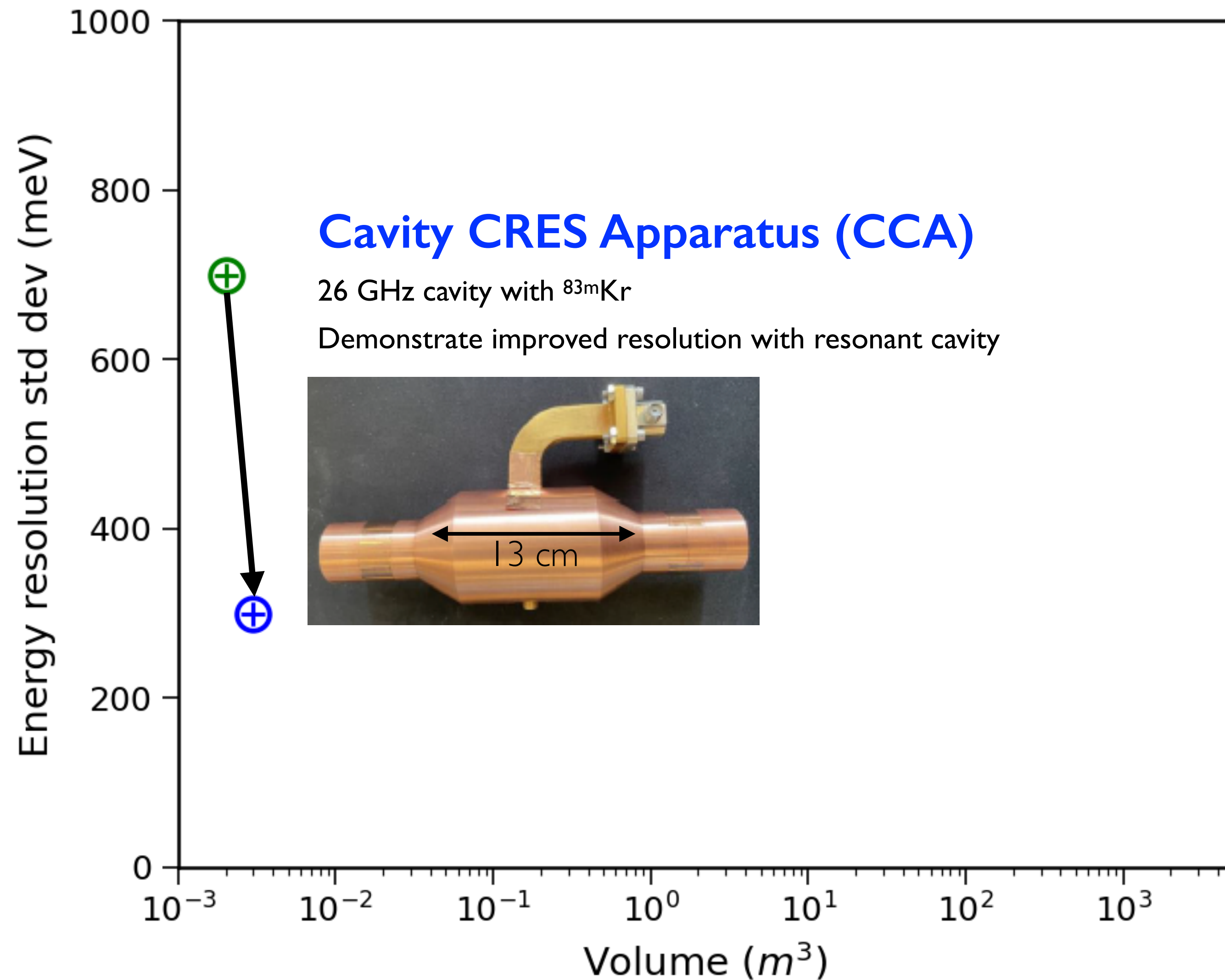

Cyclotron Radiation Signal Characterization and Noise Modeling in Resonant Cavities for Project 8
R. Mueller, W. Van De Pontseele, M. Brandsema, L. de Viveiros



Cavity CRES Apparatus (CCA): CRES with Cavity

PROJECT 8

- First demonstration of CRES in a resonant cavity with improved resolution

Commissioning ongoing!

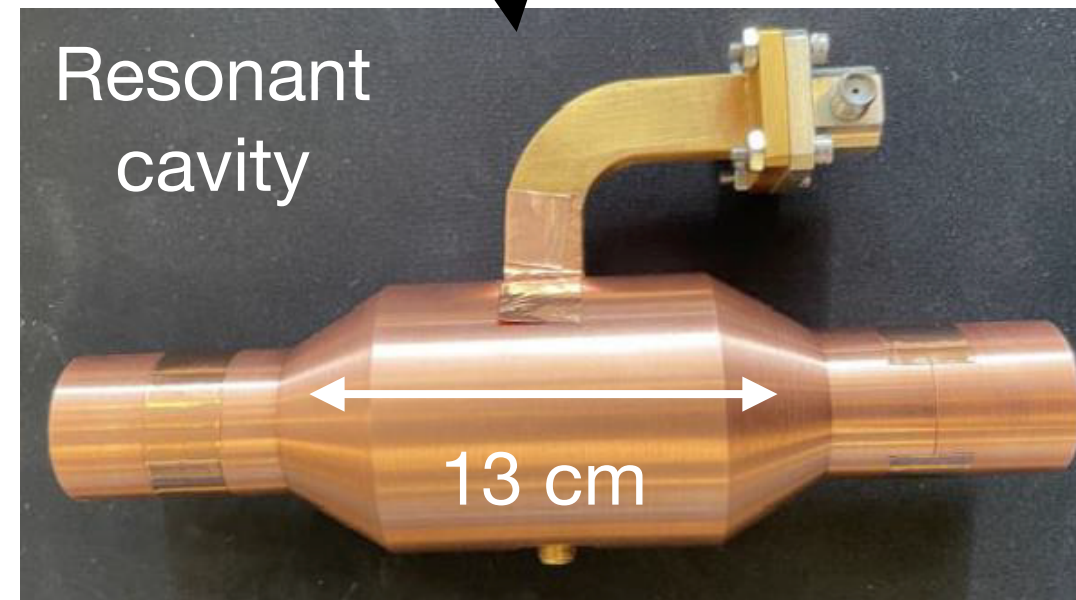
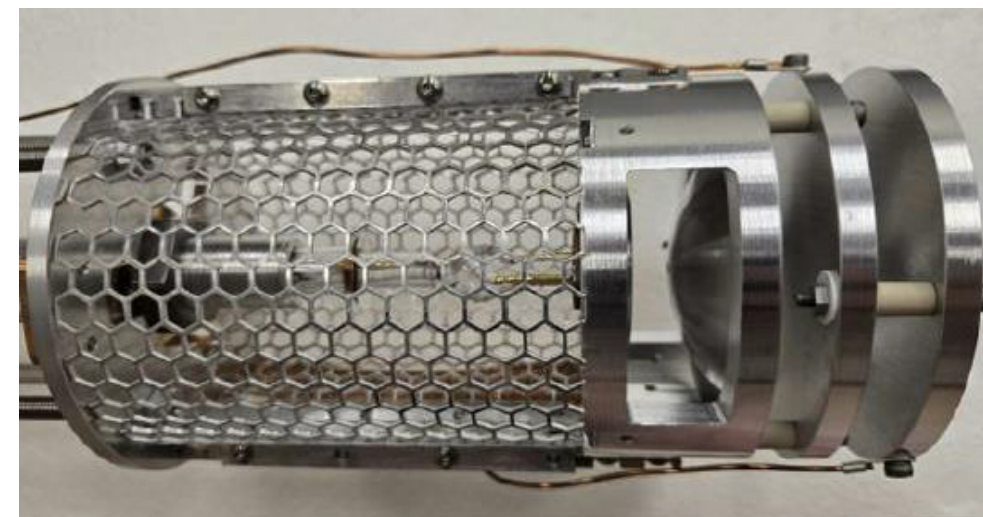
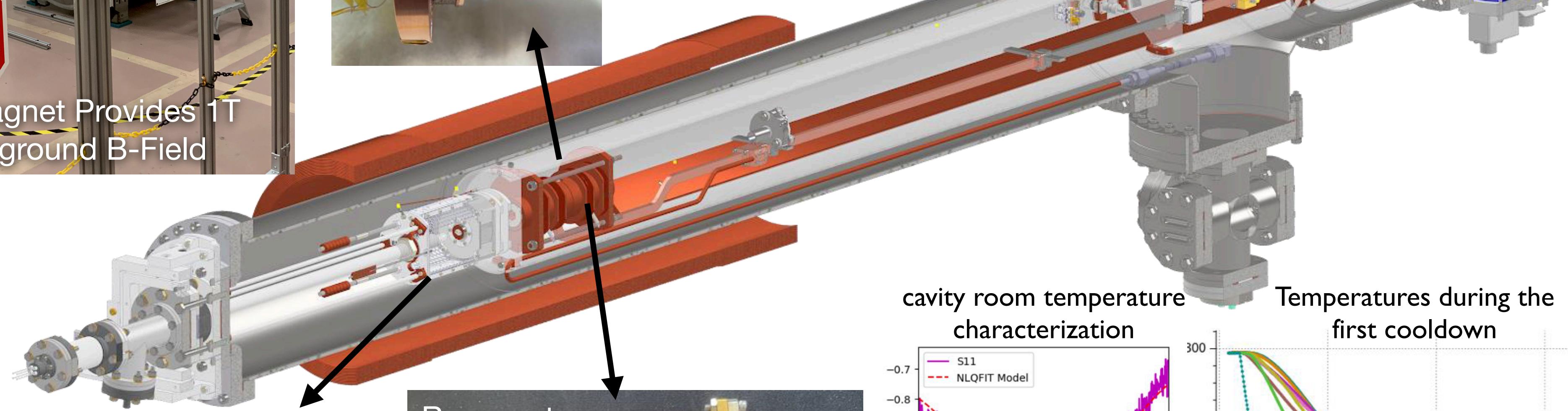
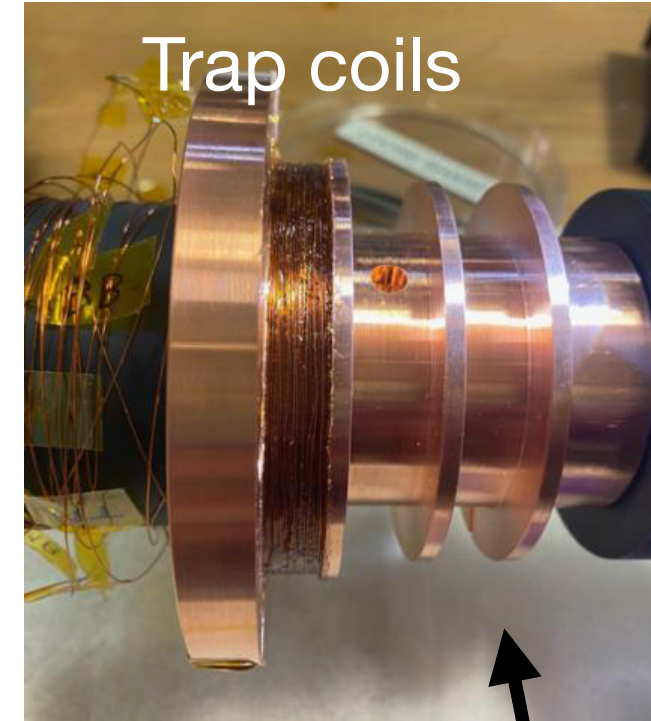
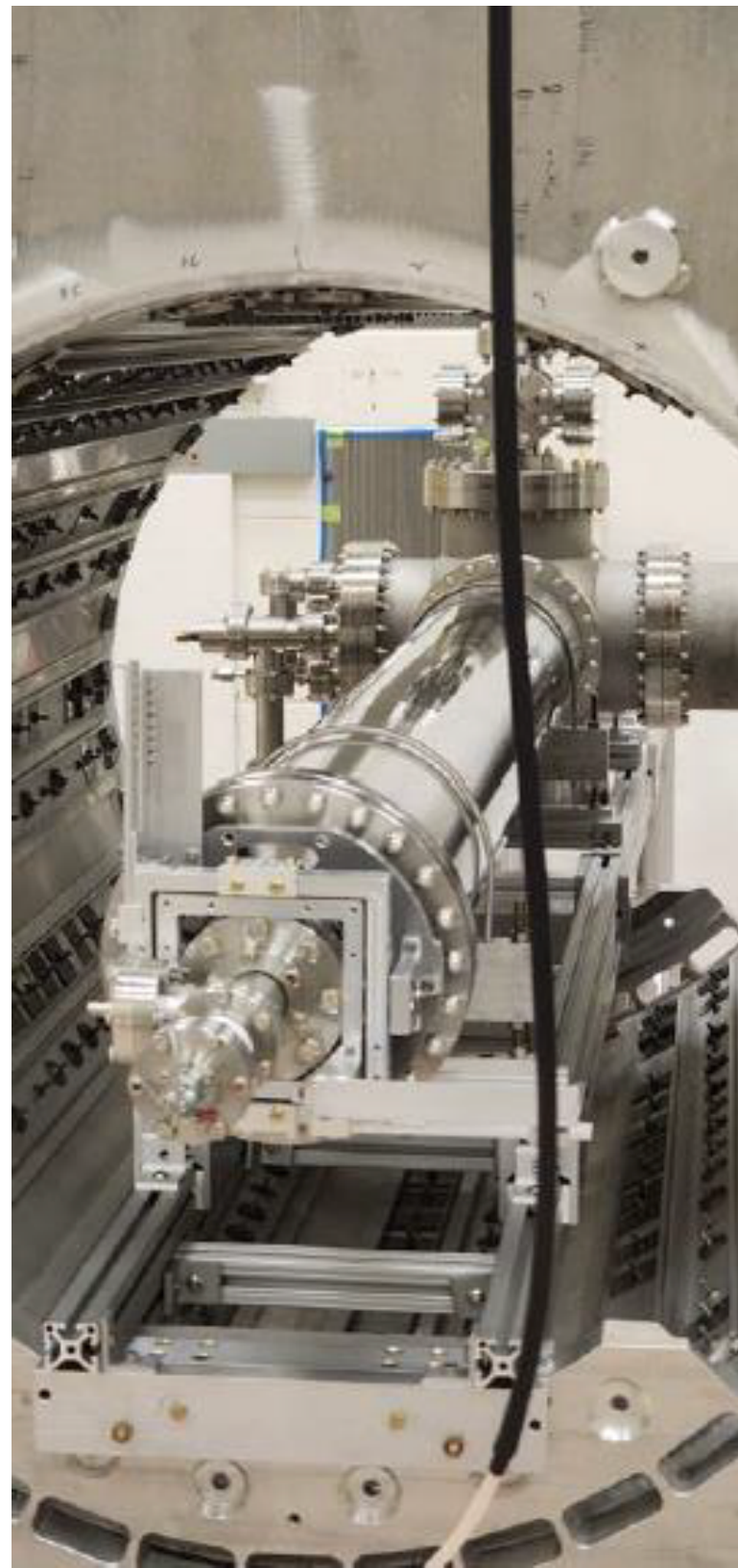

cavity room temperature characterization

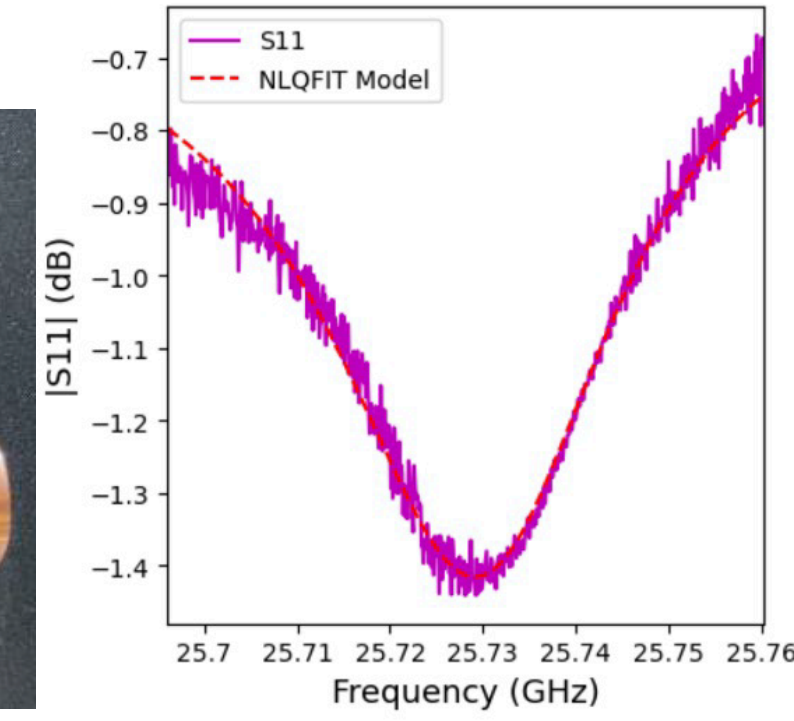

Temperatures during the first cooldown

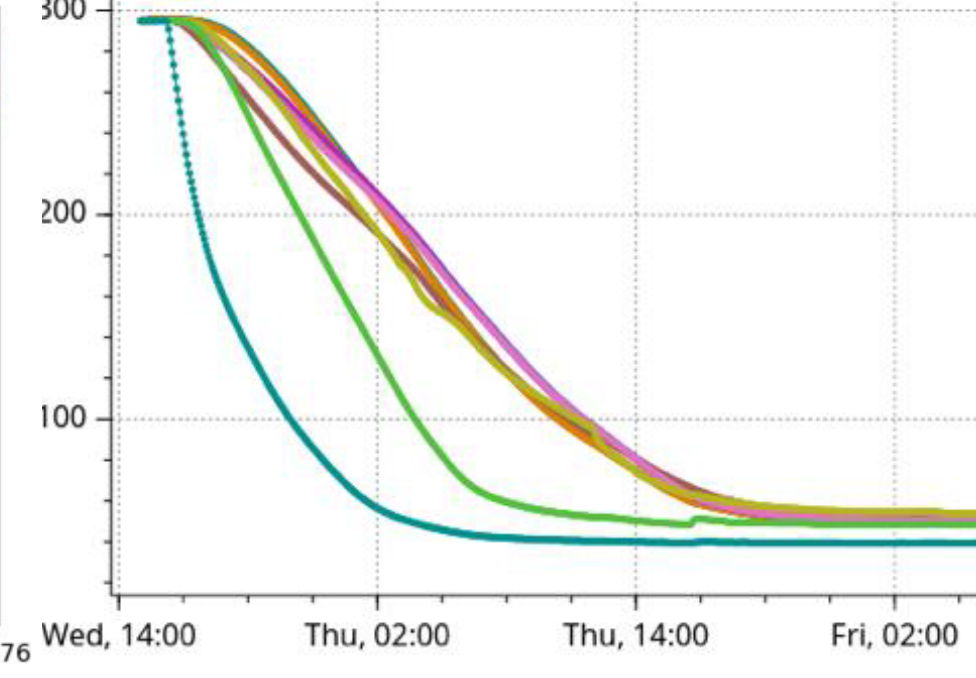



Improving Energy Resolution: Reconstruction

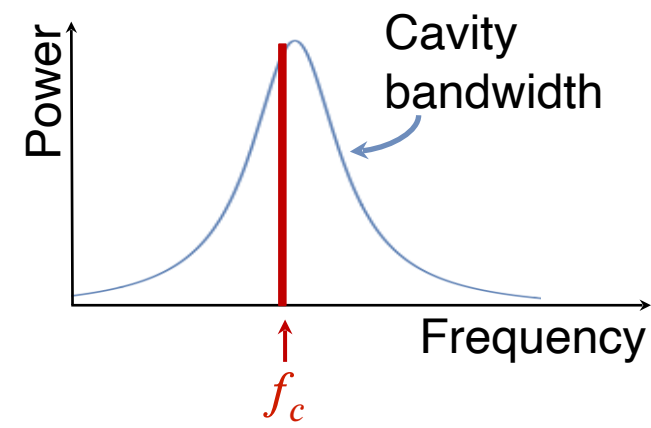
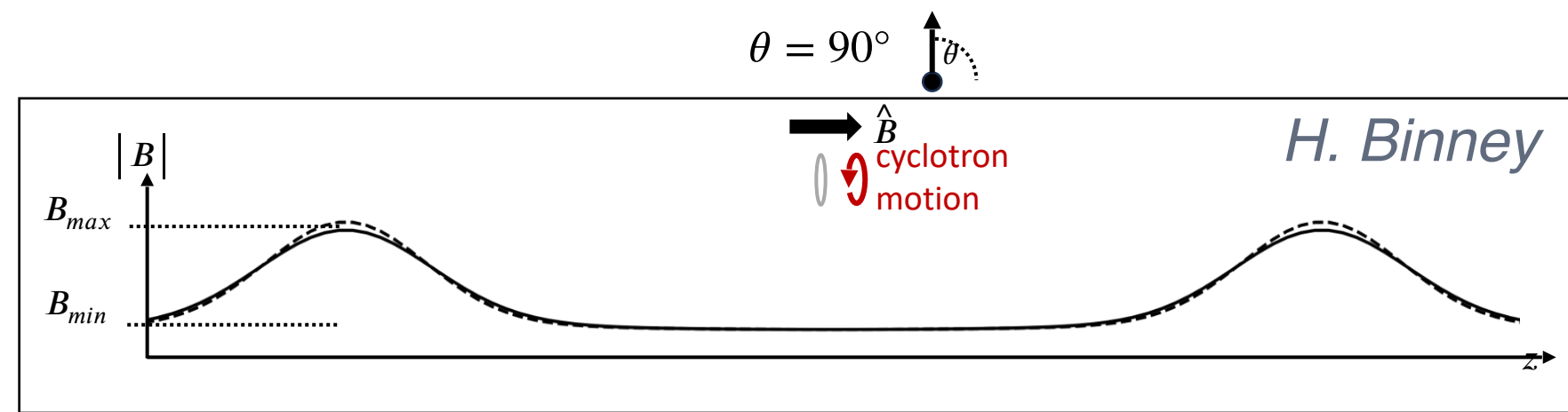

$$f_c = \frac{q\langle B \rangle}{2\pi(m_e + E_{kin})}$$



Improving Energy Resolution: Reconstruction

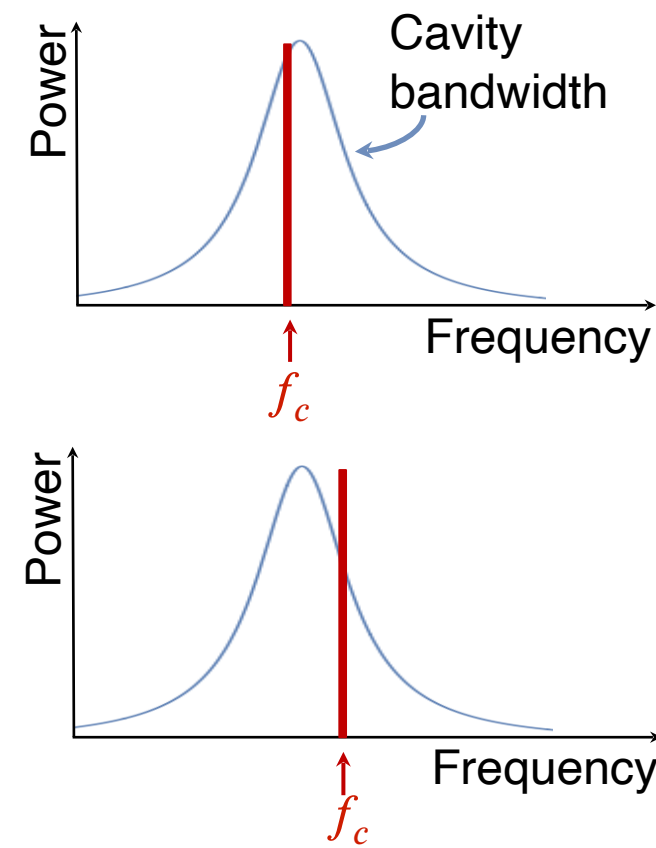
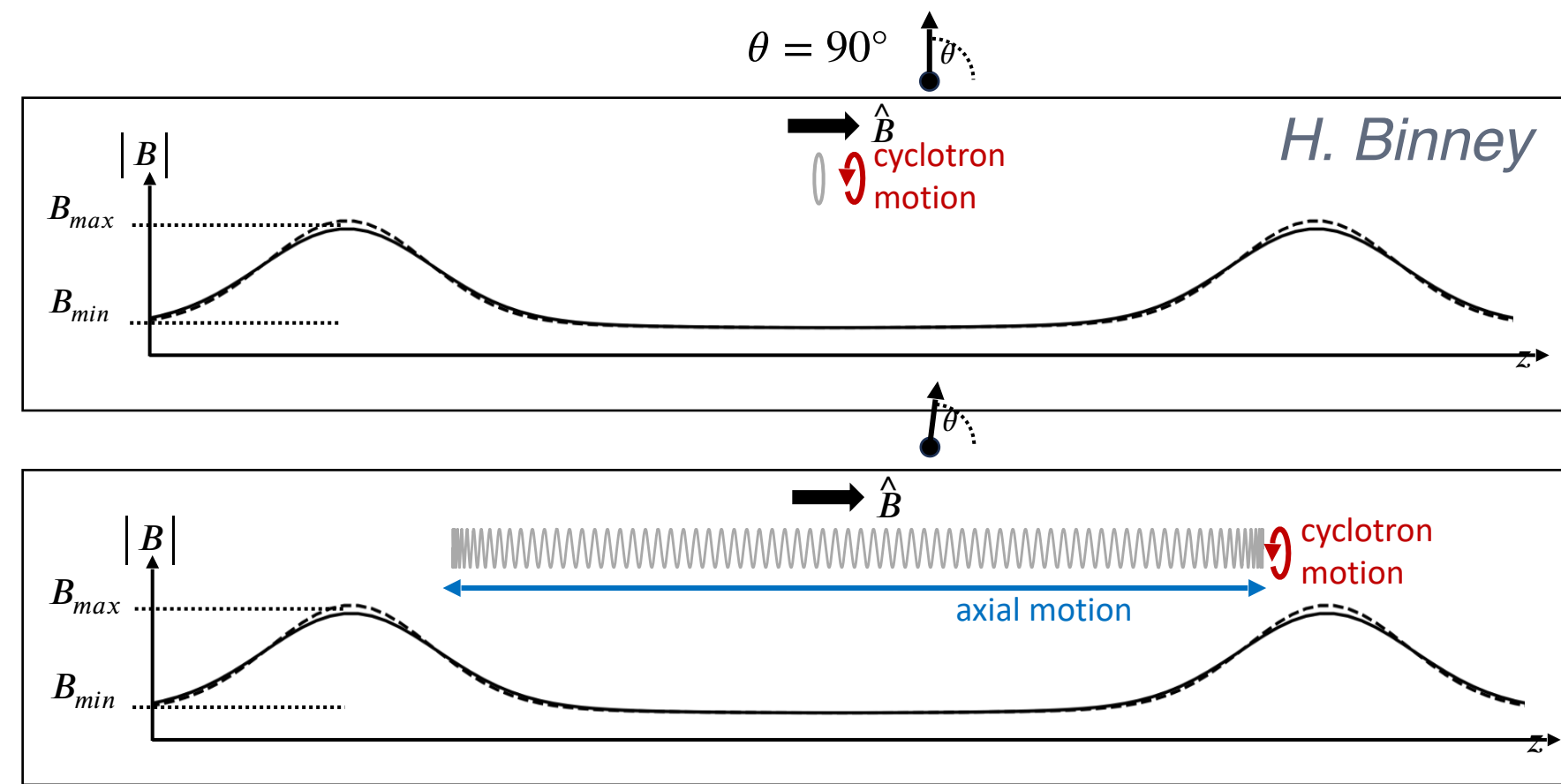

$$f_c = \frac{q\langle B \rangle}{2\pi(m_e + E_{kin})}$$

- Electron kinematics
 - Same kinetic energy could lead to different frequencies



Improving Energy Resolution: Reconstruction

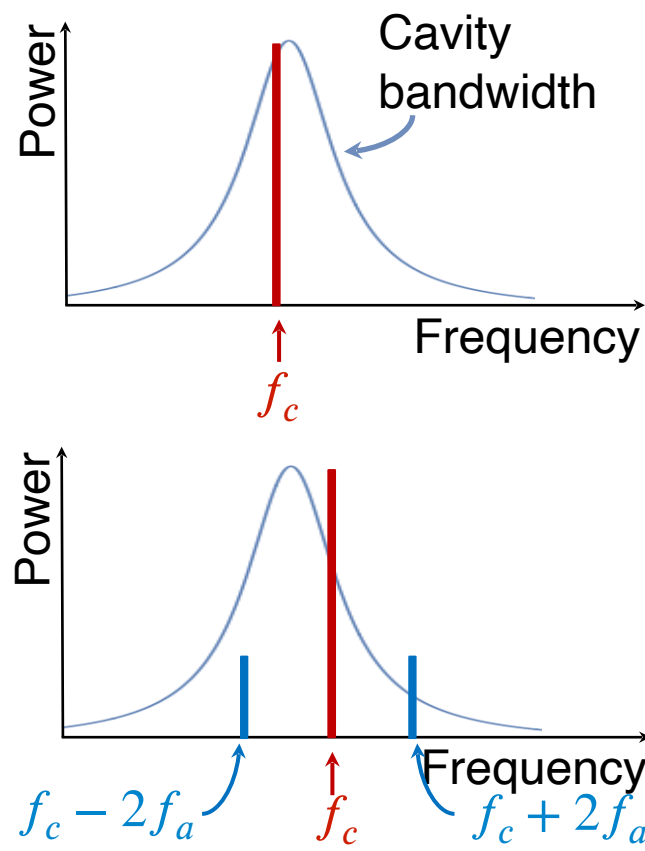
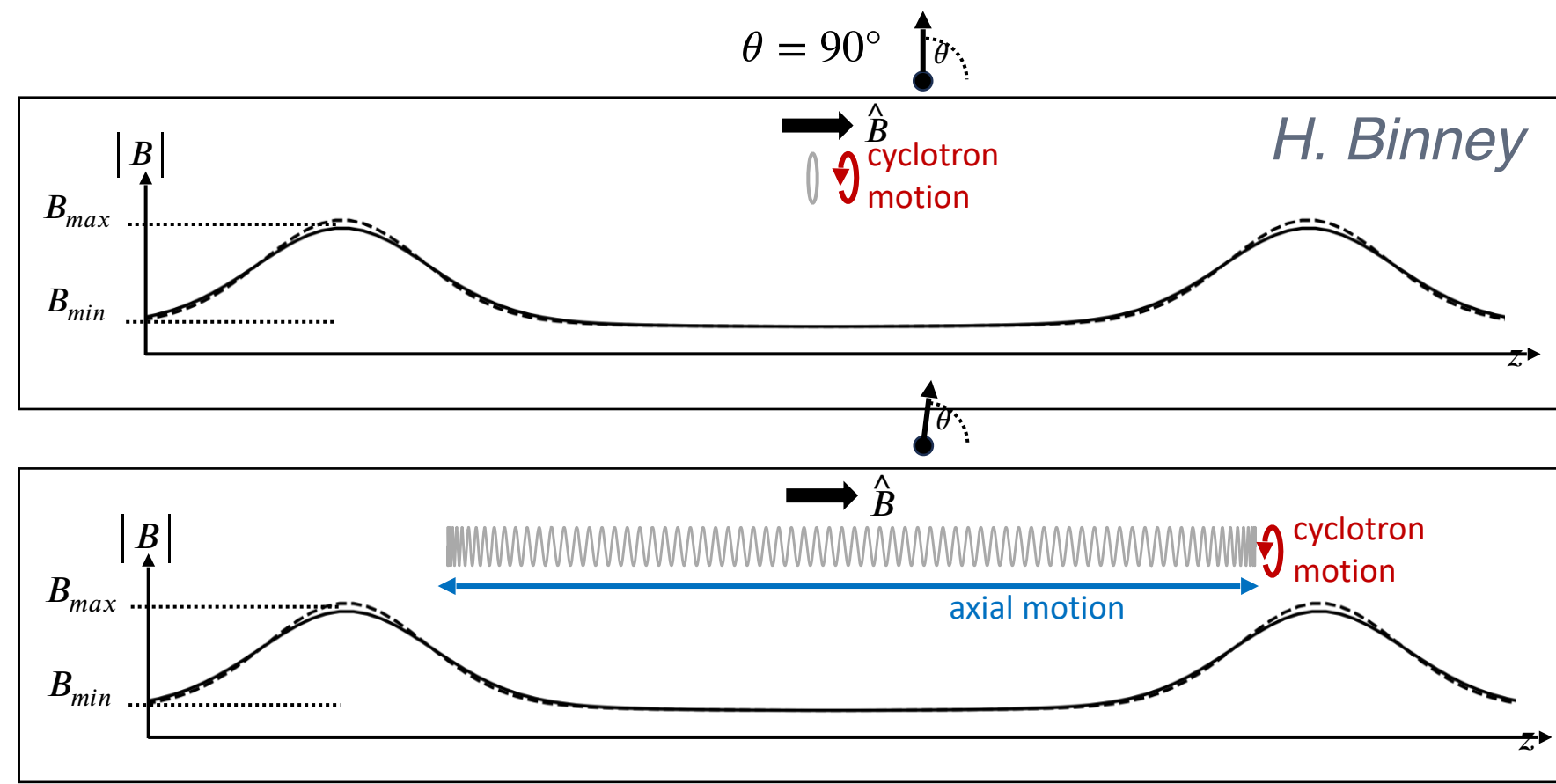

$$f_c = \frac{q \langle B \rangle}{2\pi(m_e + E_{kin})}$$

- Electron kinematics
 - Same kinetic energy could lead to different frequencies
 - Axial-frequency dependent sidebands



Improving Energy Resolution: Reconstruction

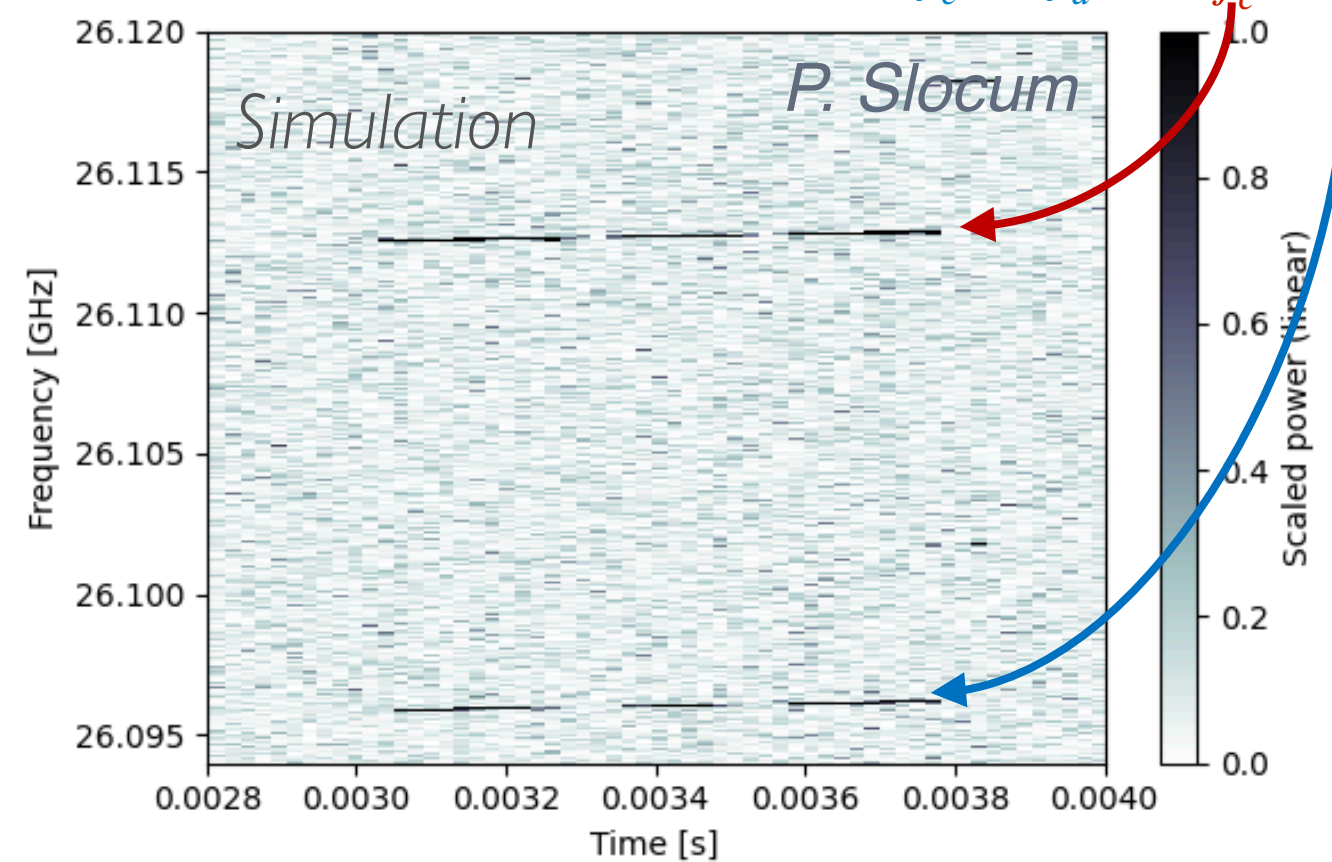
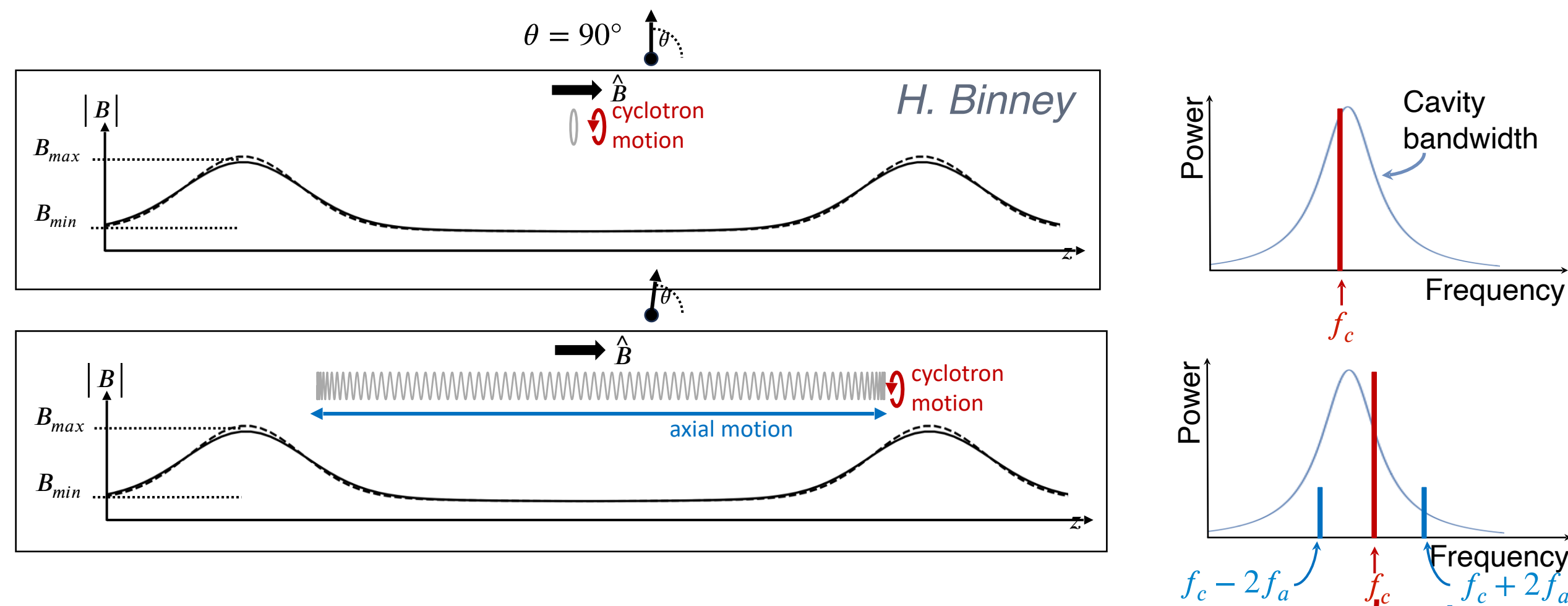

$$f_c = \frac{q \langle B \rangle}{2\pi(m_e + E_{kin})}$$

- Electron kinematics
 - Same kinetic energy could lead to different frequencies
 - Axial-frequency dependent sidebands
- Improve energy resolution by applying magnetic field correction for individual electrons



Improving Energy Resolution: Reconstruction

PROJECT 8

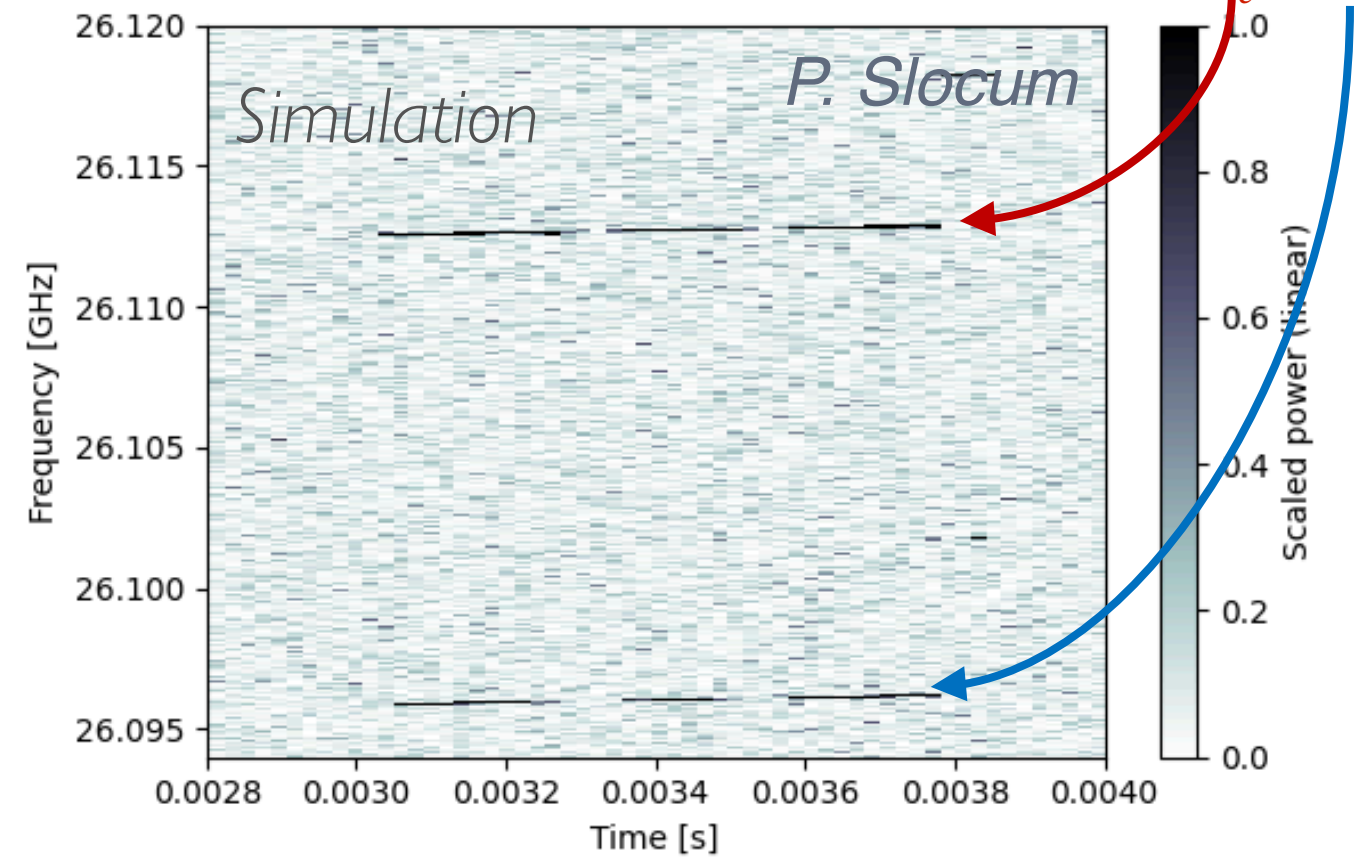
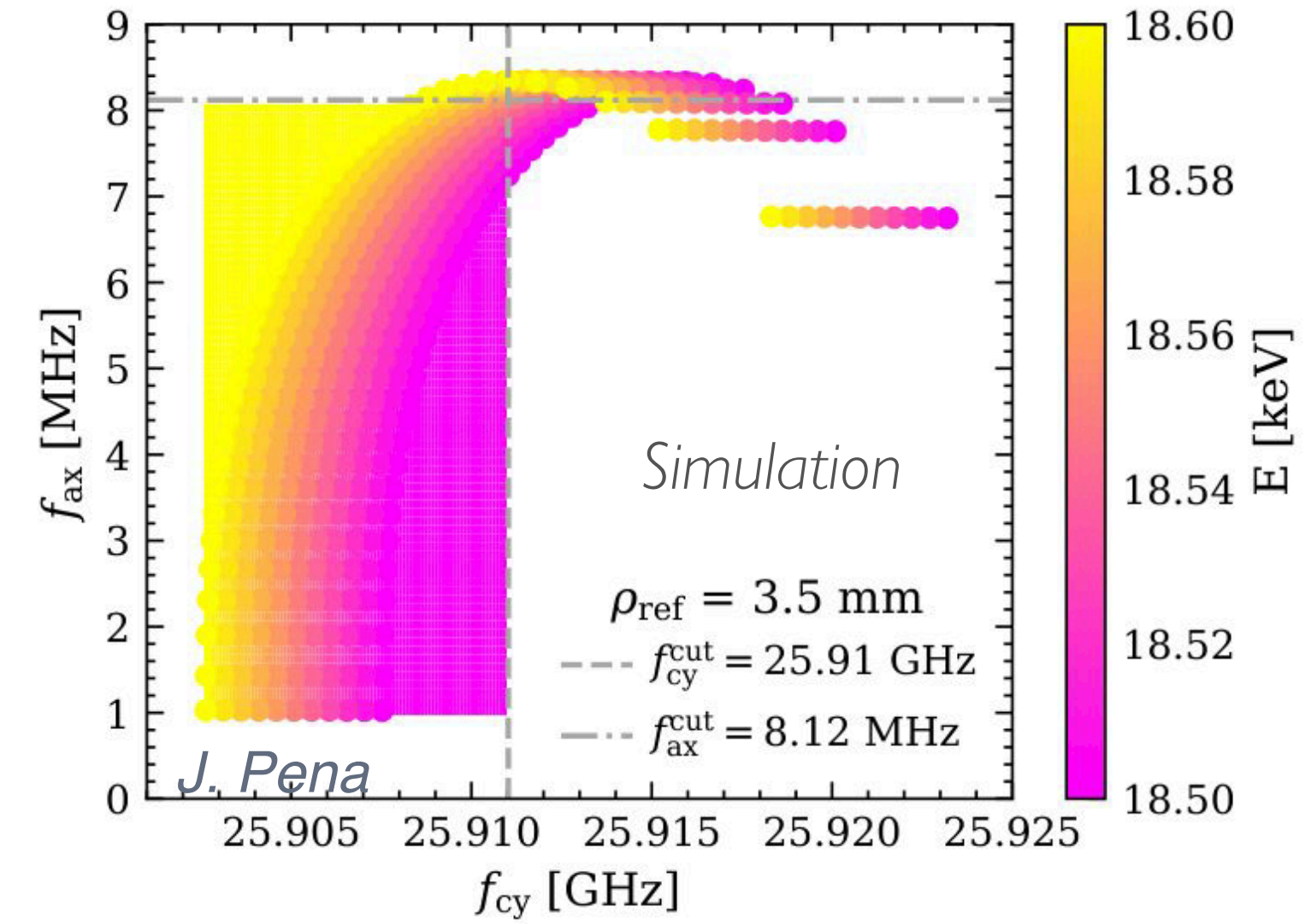
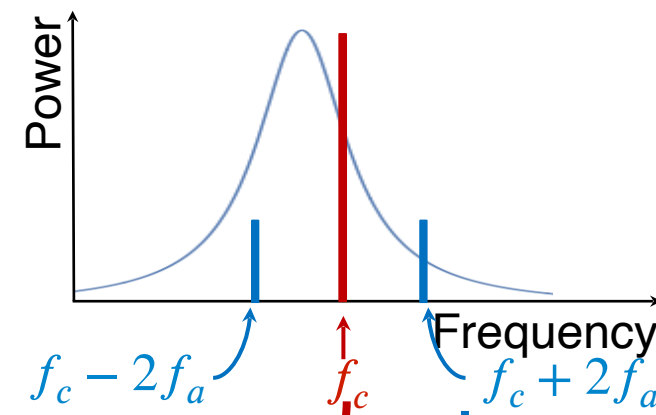
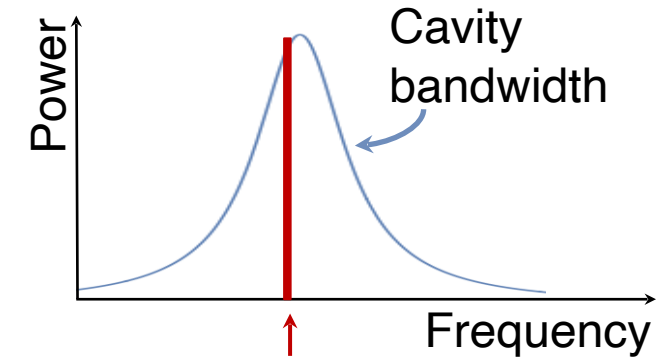
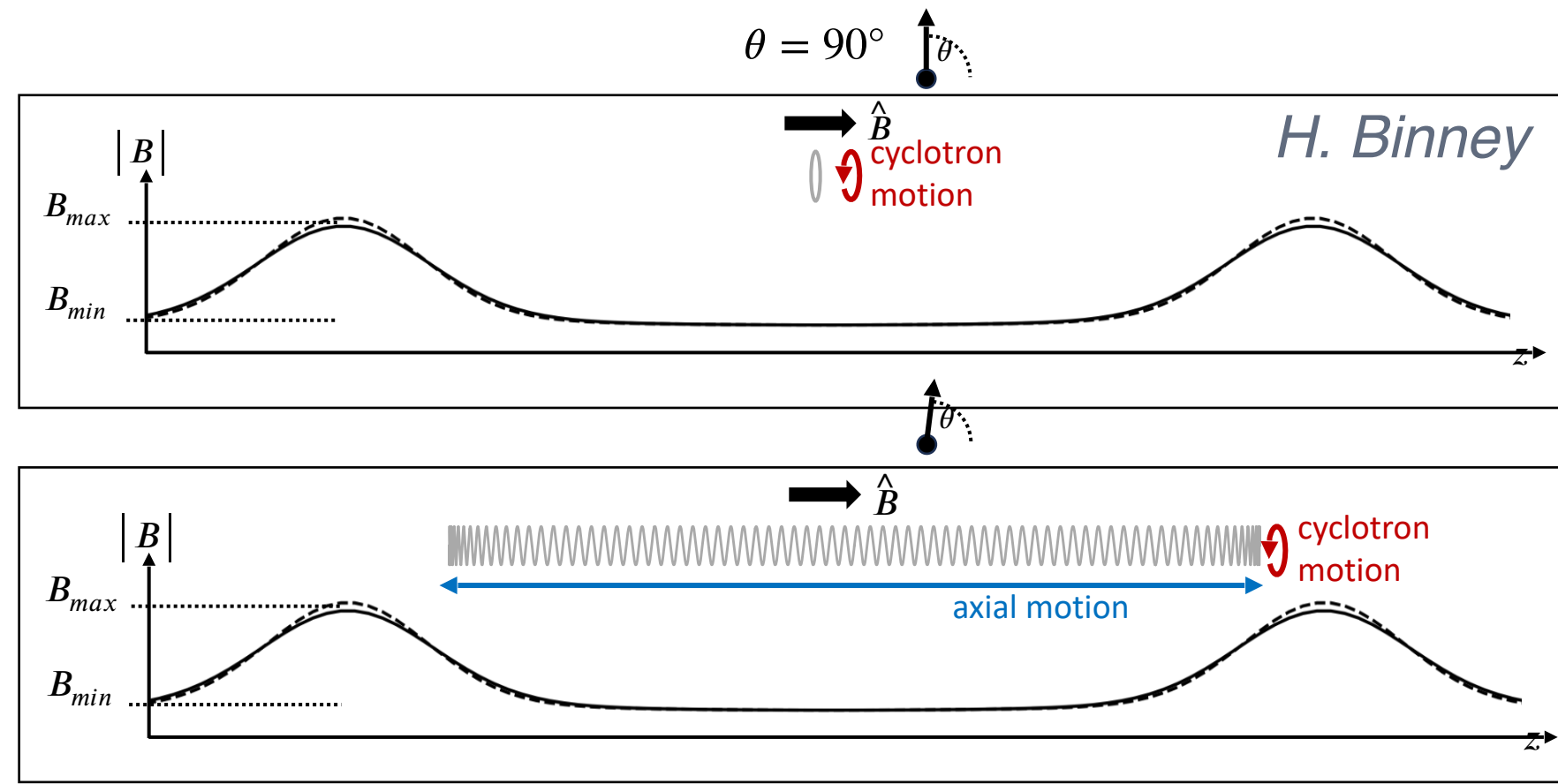

$$f_c = \frac{q \langle B \rangle}{2\pi(m_e + E_{kin})}$$

- Electron kinematics
 - Same kinetic energy could lead to different frequencies
 - Axial-frequency dependent sidebands
- Improve energy resolution by applying magnetic field correction for individual electrons



Improving Energy Resolution: Reconstruction

PROJECT 8

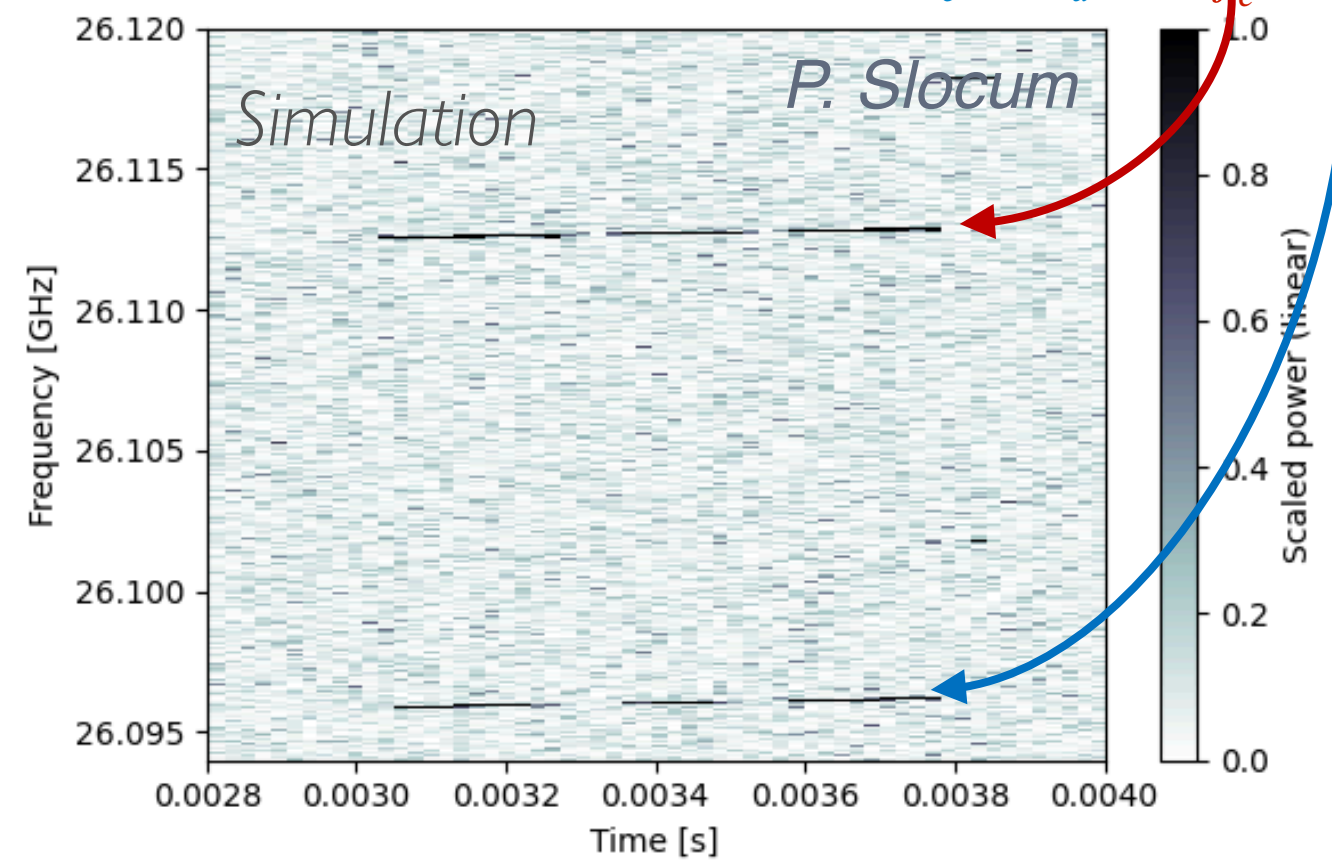
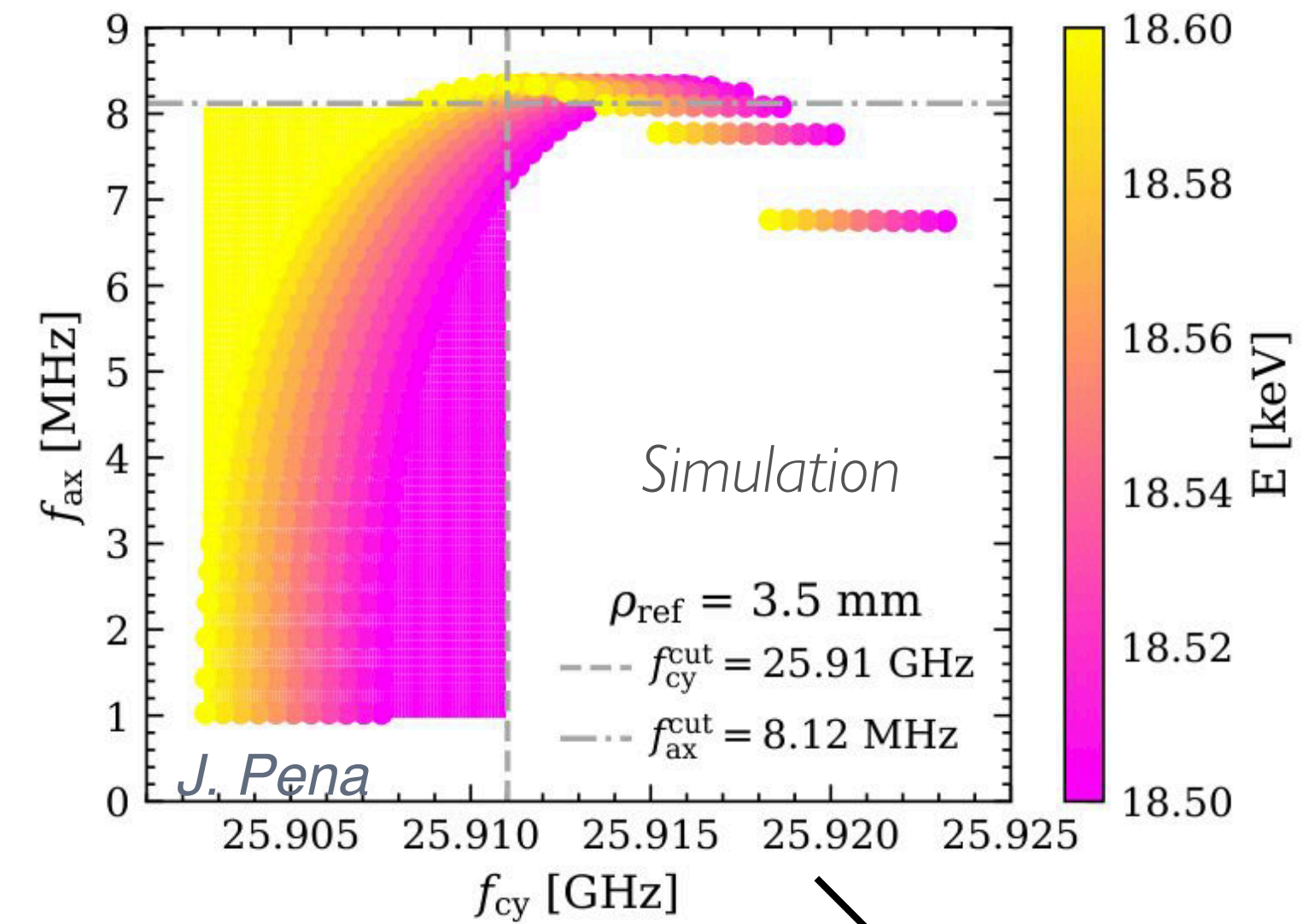
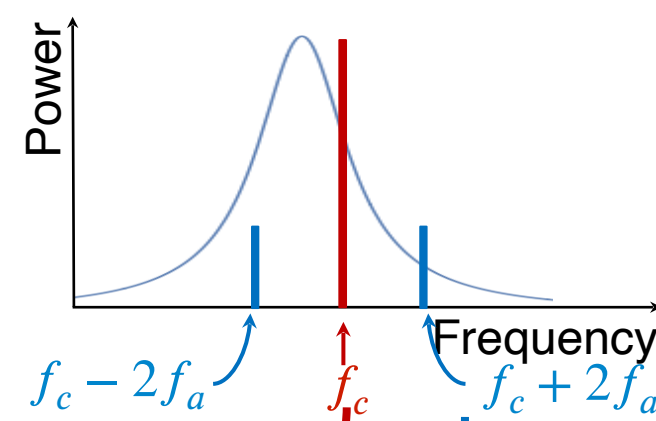
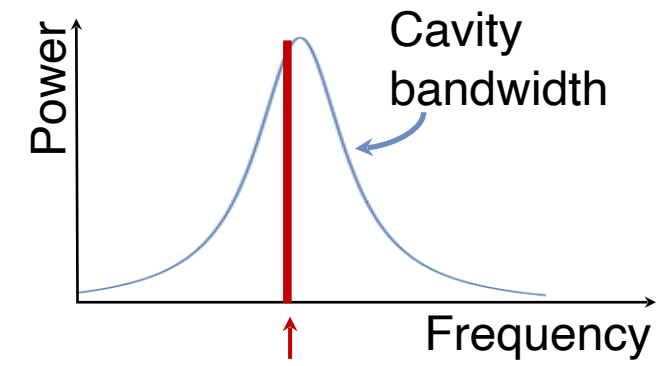
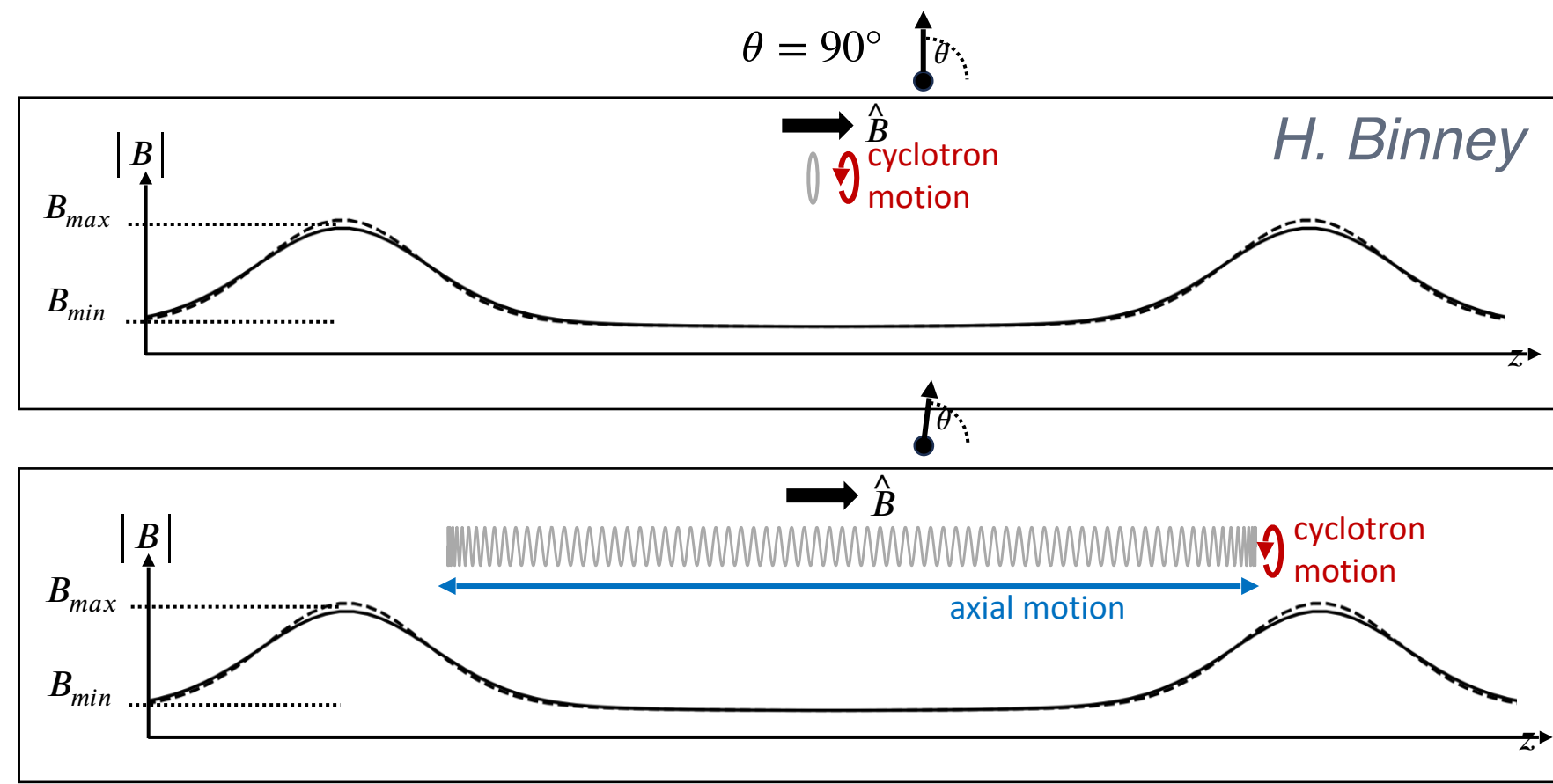

- CCA target resolution demonstrated with nominal reconstruction algorithm
- Several other approaches under investigation

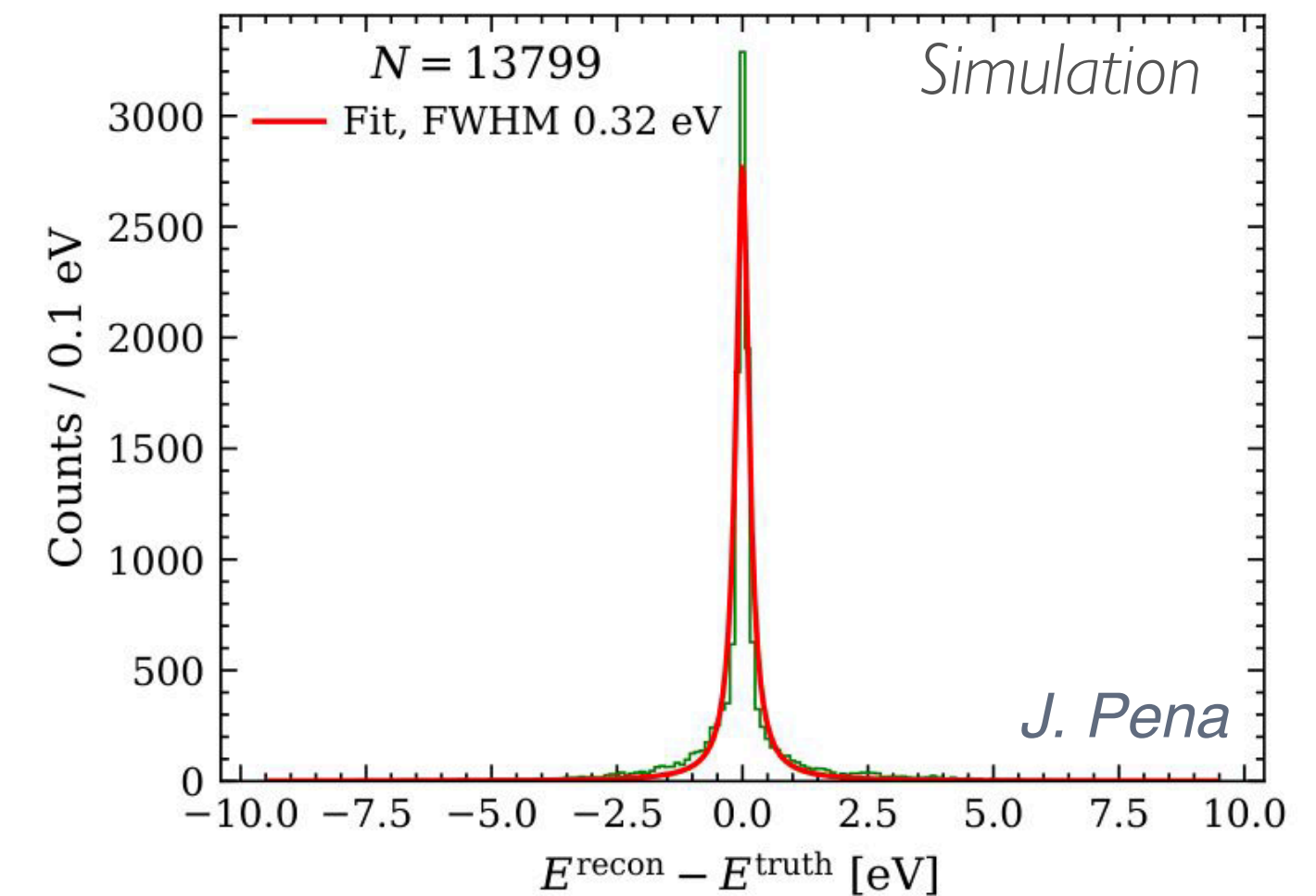

$$f_c = \frac{q \langle B \rangle}{2\pi(m_e + E_{kin})}$$

- Electron kinematics
 - Same kinetic energy could lead to different frequencies
 - Axial-frequency dependent sidebands
- Improve energy resolution by applying magnetic field correction for individual electrons



Improving Energy Resolution: Reconstruction

PROJECT 8

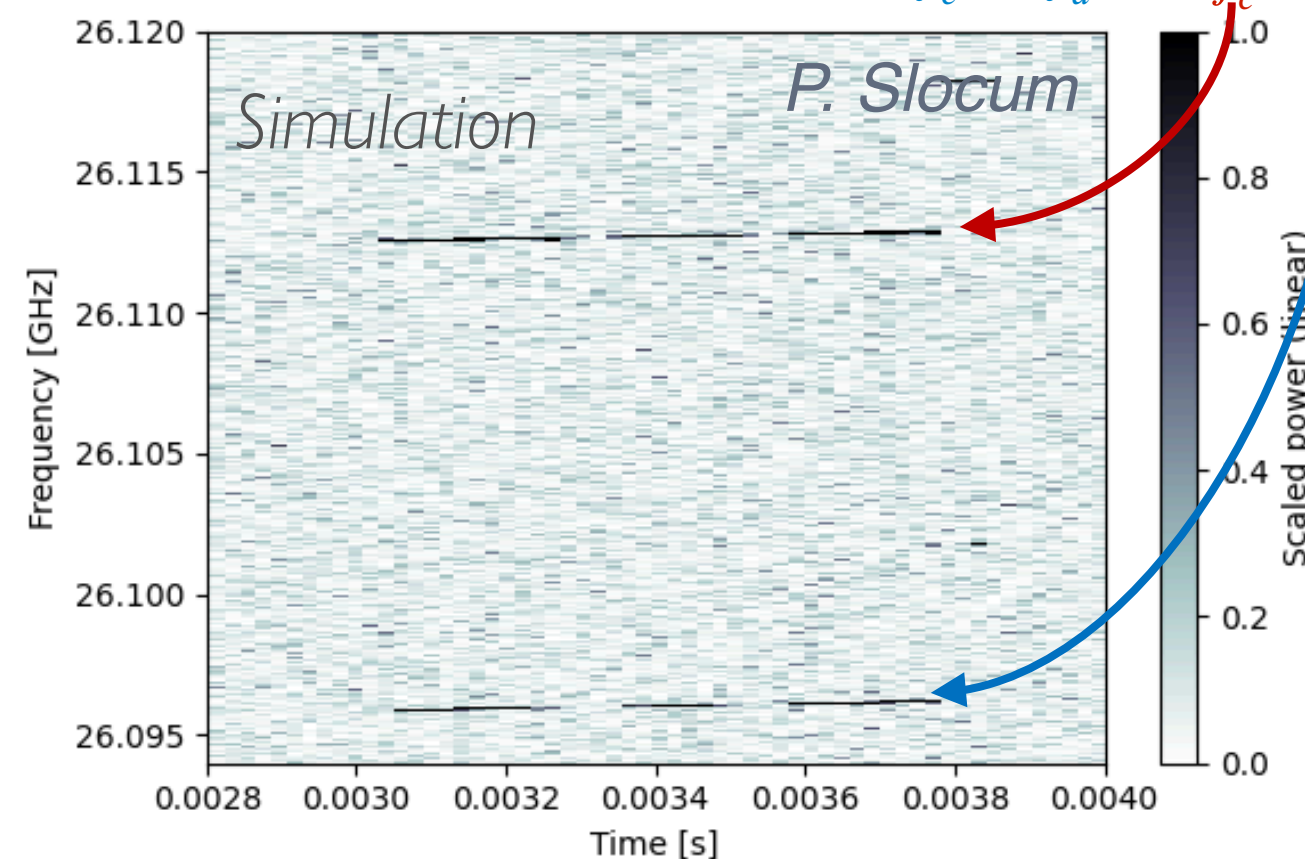
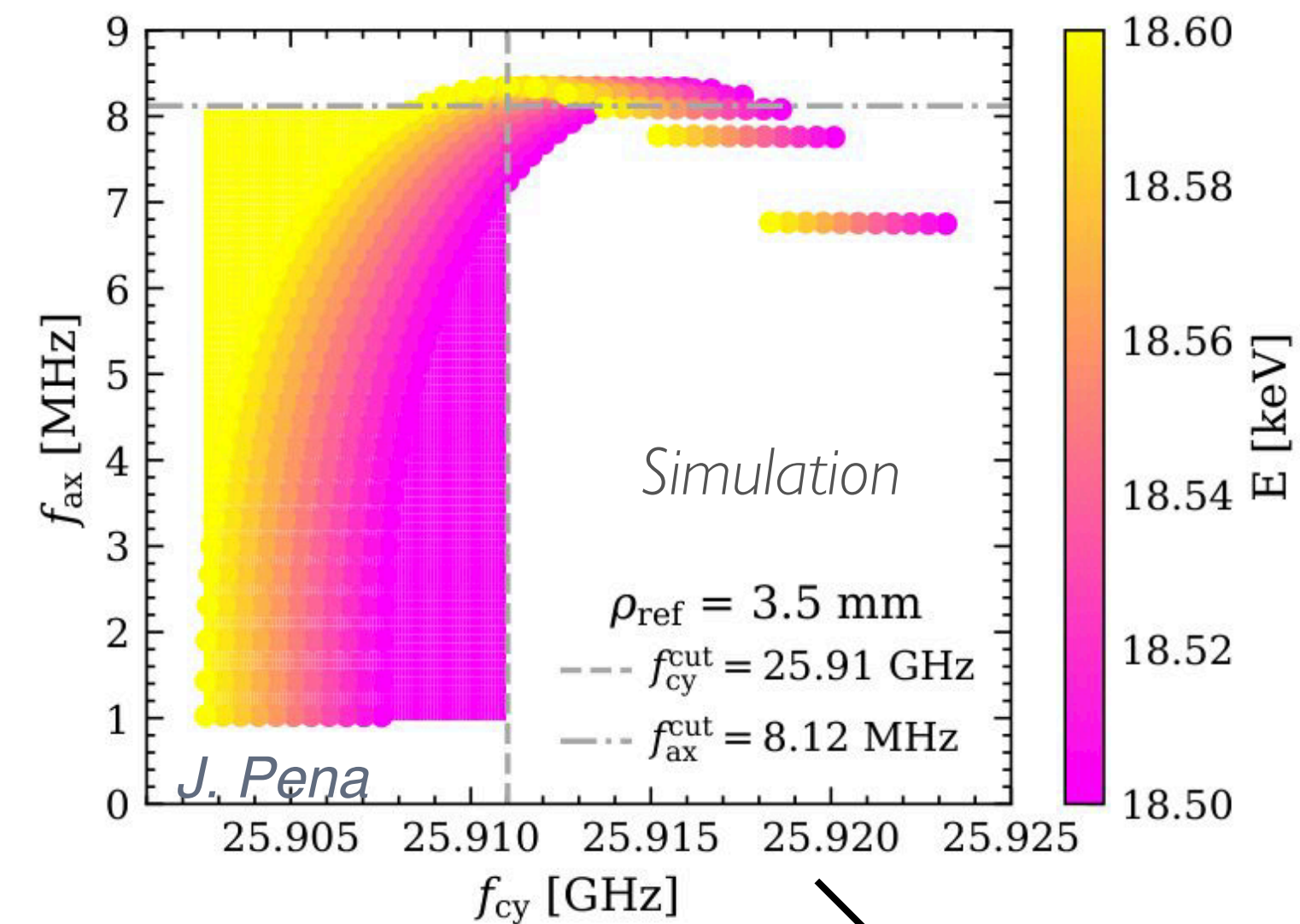
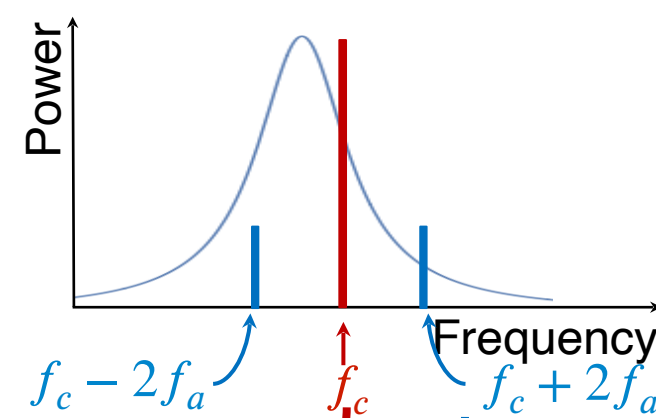
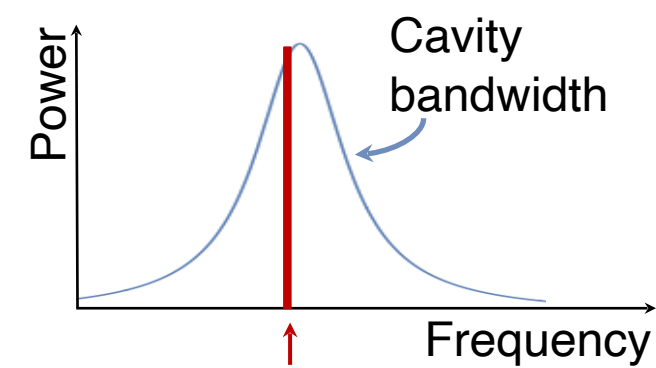
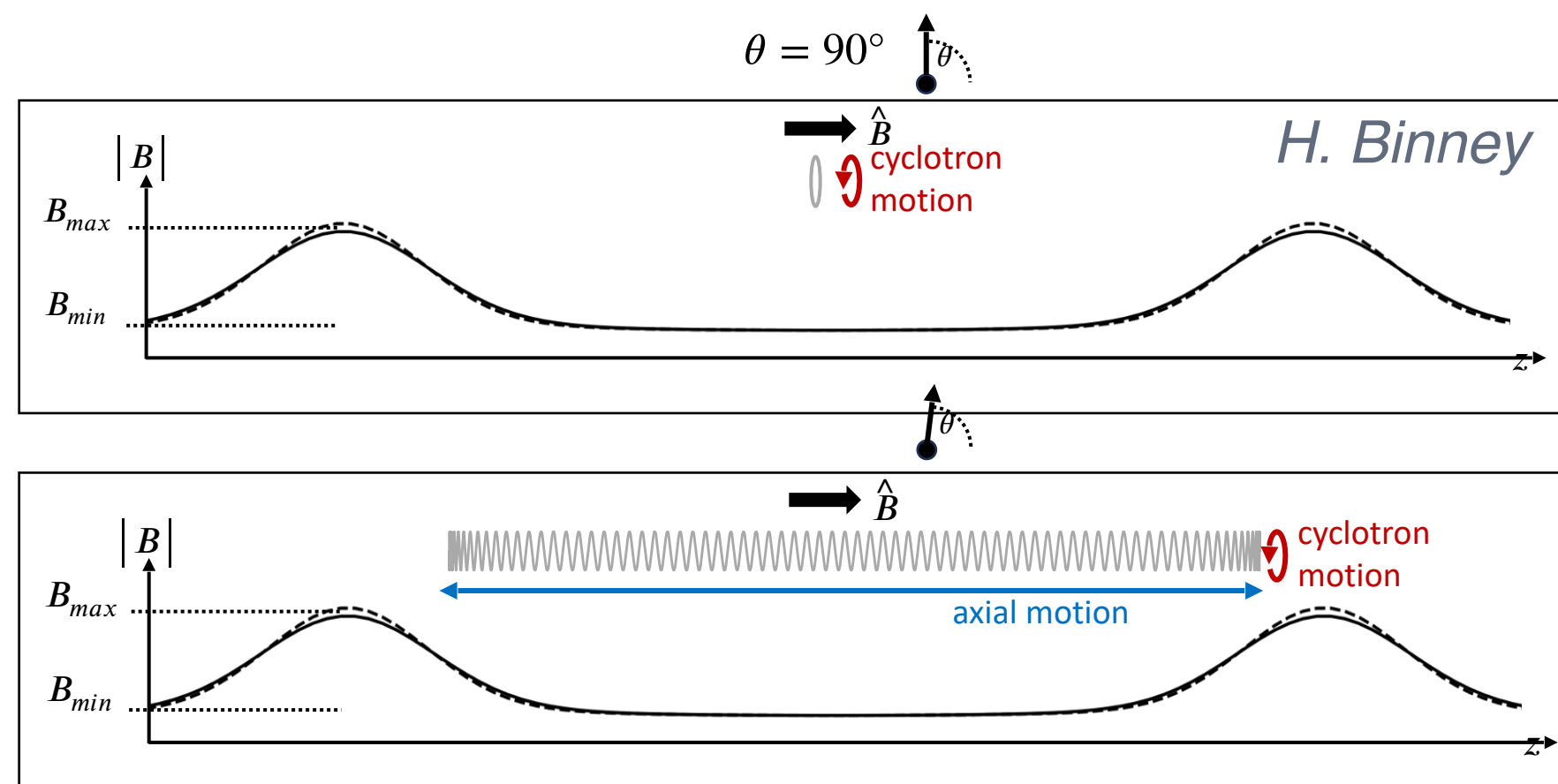

- CCA target resolution demonstrated with nominal reconstruction algorithm
- Several other approaches under investigation

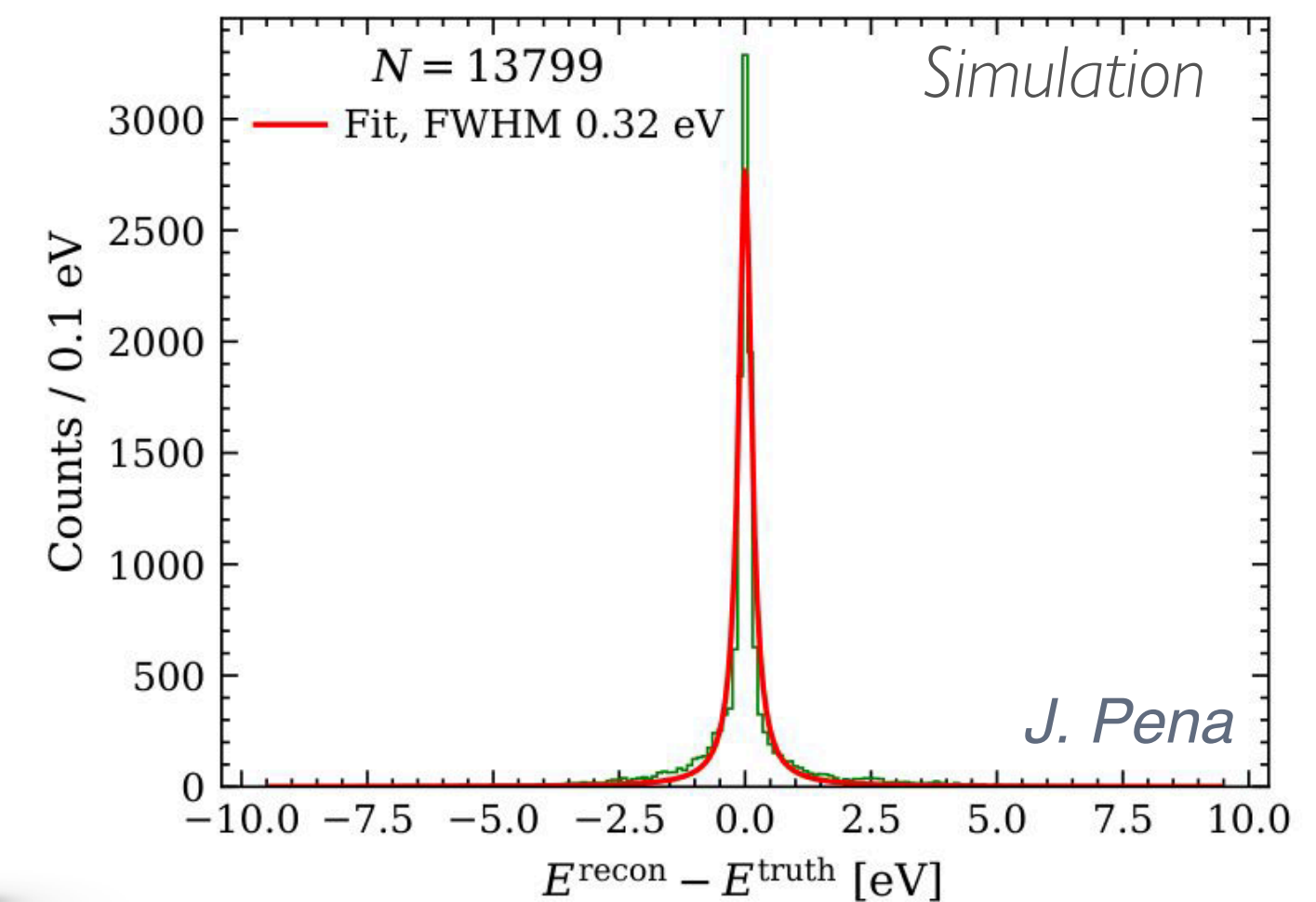

$$f_c = \frac{q\langle B \rangle}{2\pi(m_e + E_{kin})}$$

Event Reconstruction for sub-eV Energy Resolution in the Project 8 Neutrino Mass Experiment
H. Binney, V. Sharma, J. Pena, P. Slocum

- Electron kinematics
 - Same kinetic energy could lead to different frequencies
 - Axial-frequency dependent sidebands
- Improve energy resolution by applying magnetic field correction for individual electrons





Electron gun for tunable nearly mono-energetic electrons





Electron gun for tunable nearly mono-energetic electrons



M. Kallander

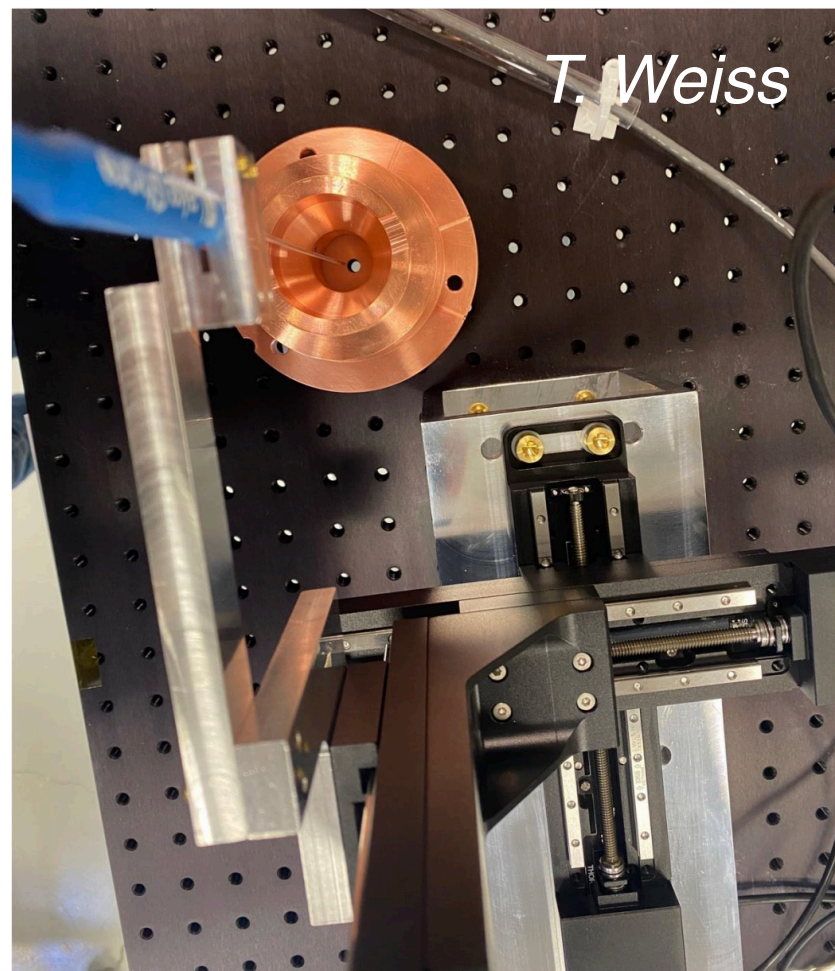

T. Weiss

Hall probe to map the CRES trap coils



Improving Energy Resolution: Detector Design and Calibrations

PROJECT 8

Electron gun for tunable nearly mono-energetic electrons



M. Kallander



P. Kolbeck

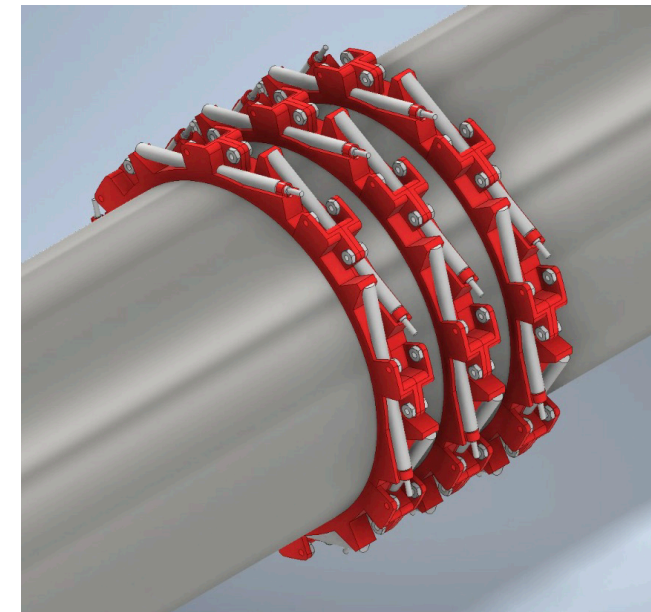

Proton NMR for magnetic field monitoring outside the cryogenic region

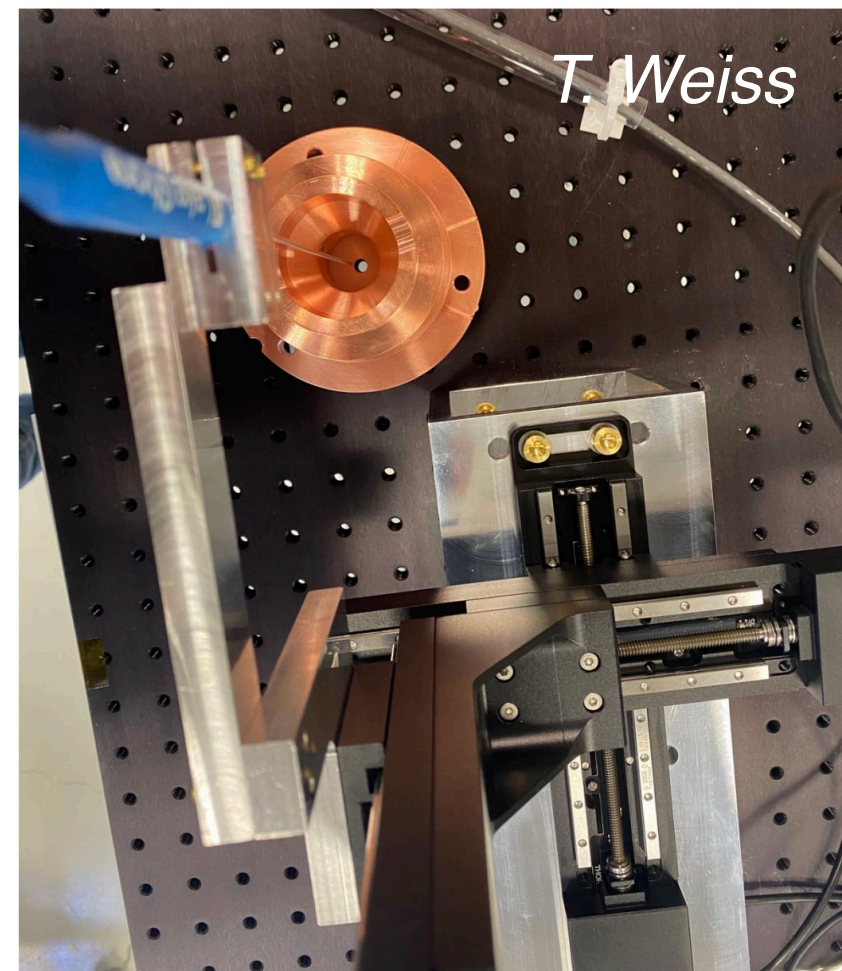

T. Weiss

A. Kurmus, S. Kuenstner



CRES-compatible **NMR magnetometry** for *in situ* characterization using hyper-polarized ^3He

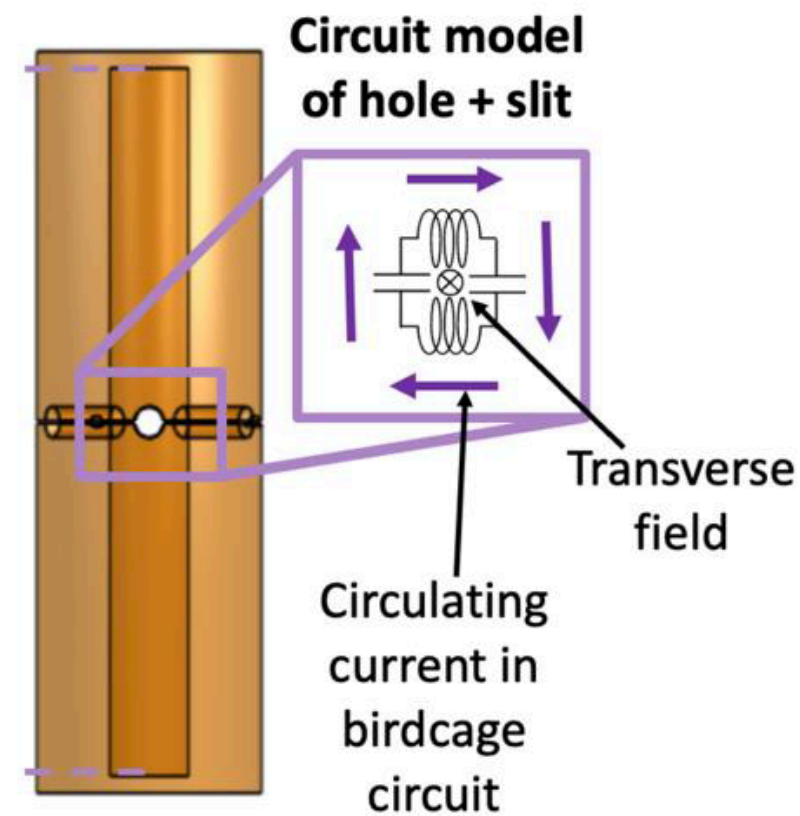

Circuit model of hole + slit

Transverse field

Circulating current in birdcage circuit

Hall probe to map the CRES trap coils



Improving Energy Resolution: Detector Design and Calibrations

PROJECT 8

Electron gun for tunable nearly mono-energetic electrons

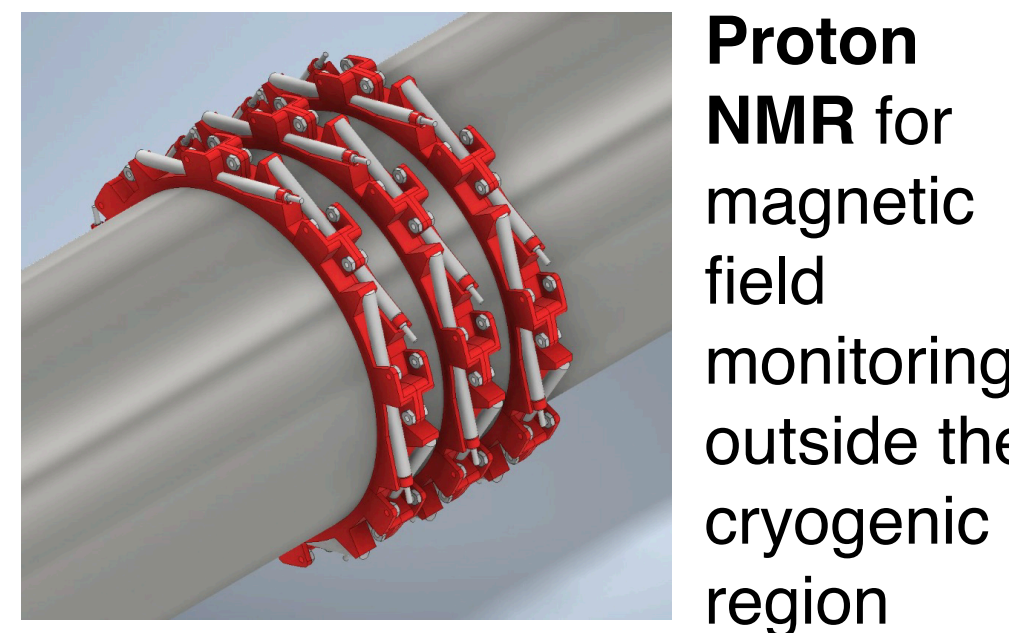

Proton NMR for magnetic field monitoring outside the cryogenic region

Developing multimode resonant cavities for improved reconstruction

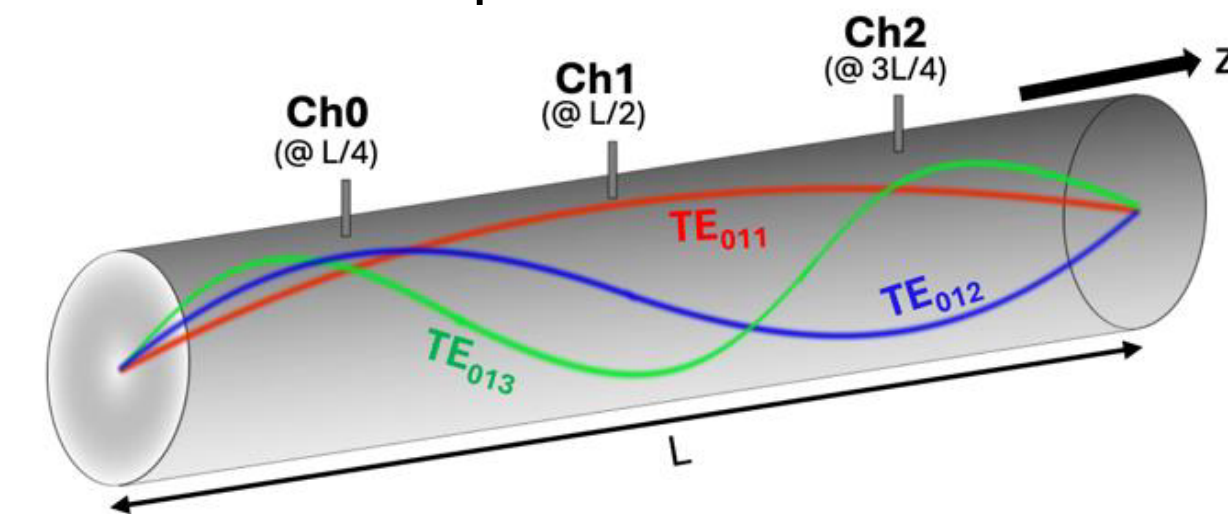

Mode filtering and readout development

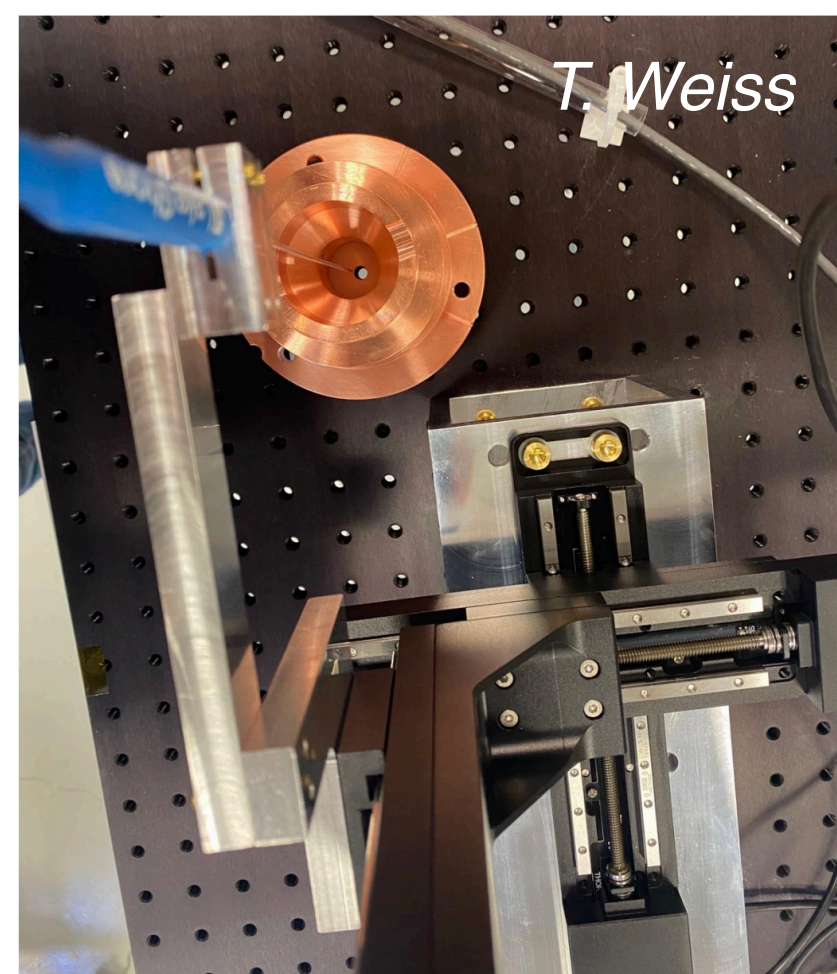
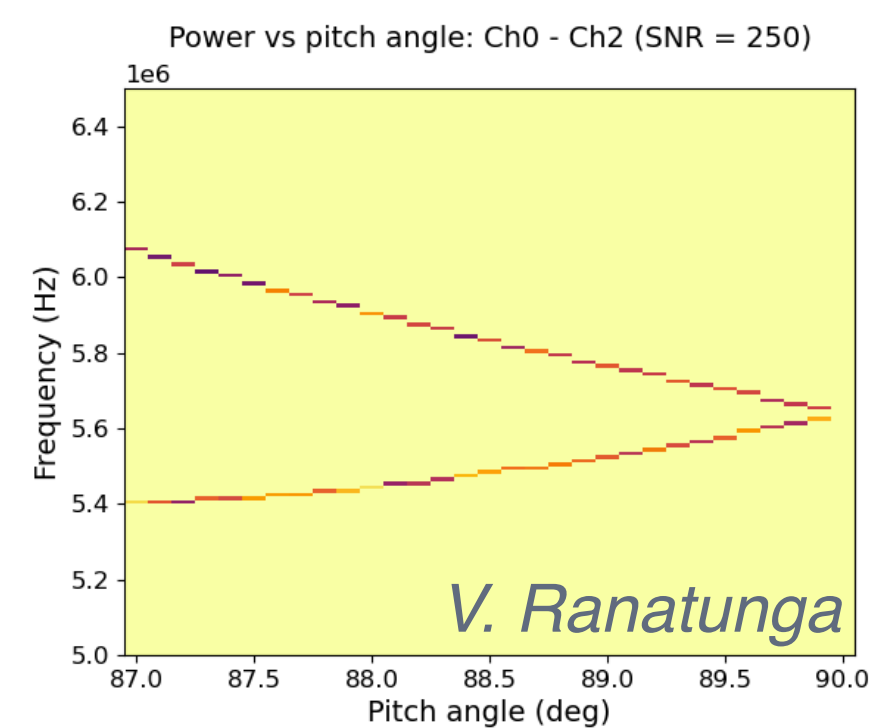
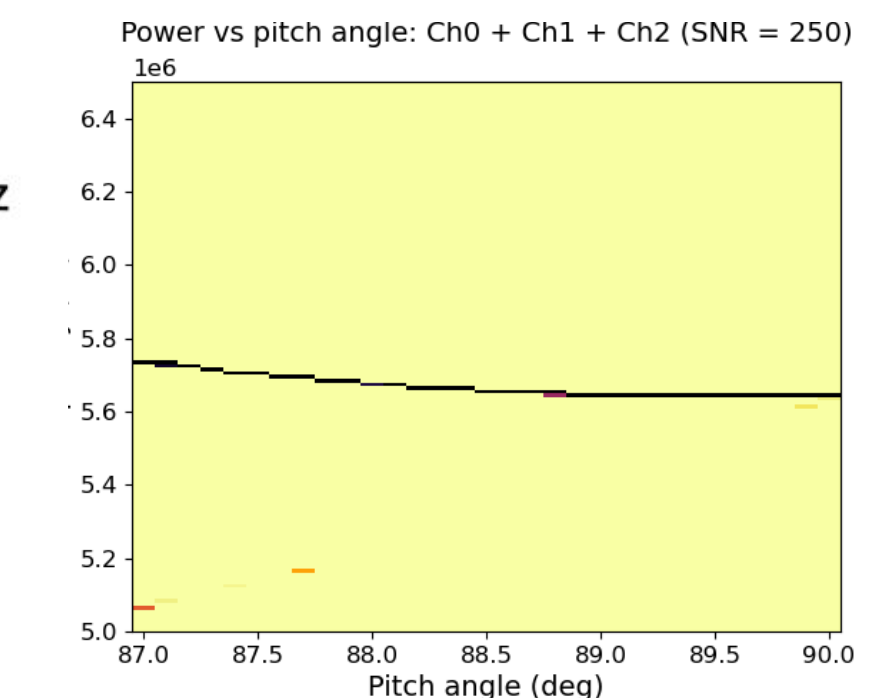
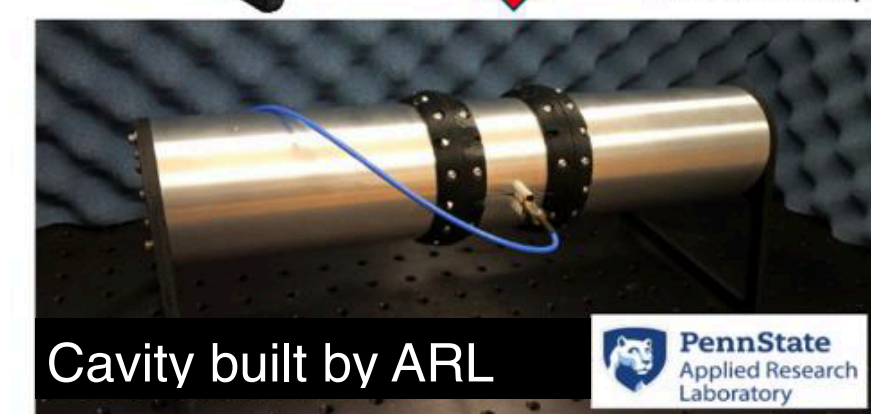
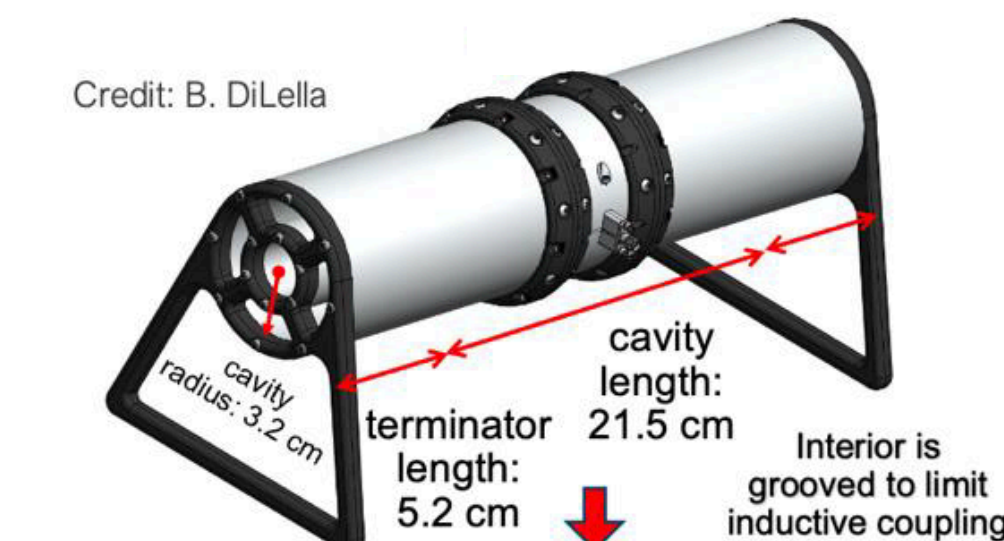

A. Kurmus, S. Kuenstner

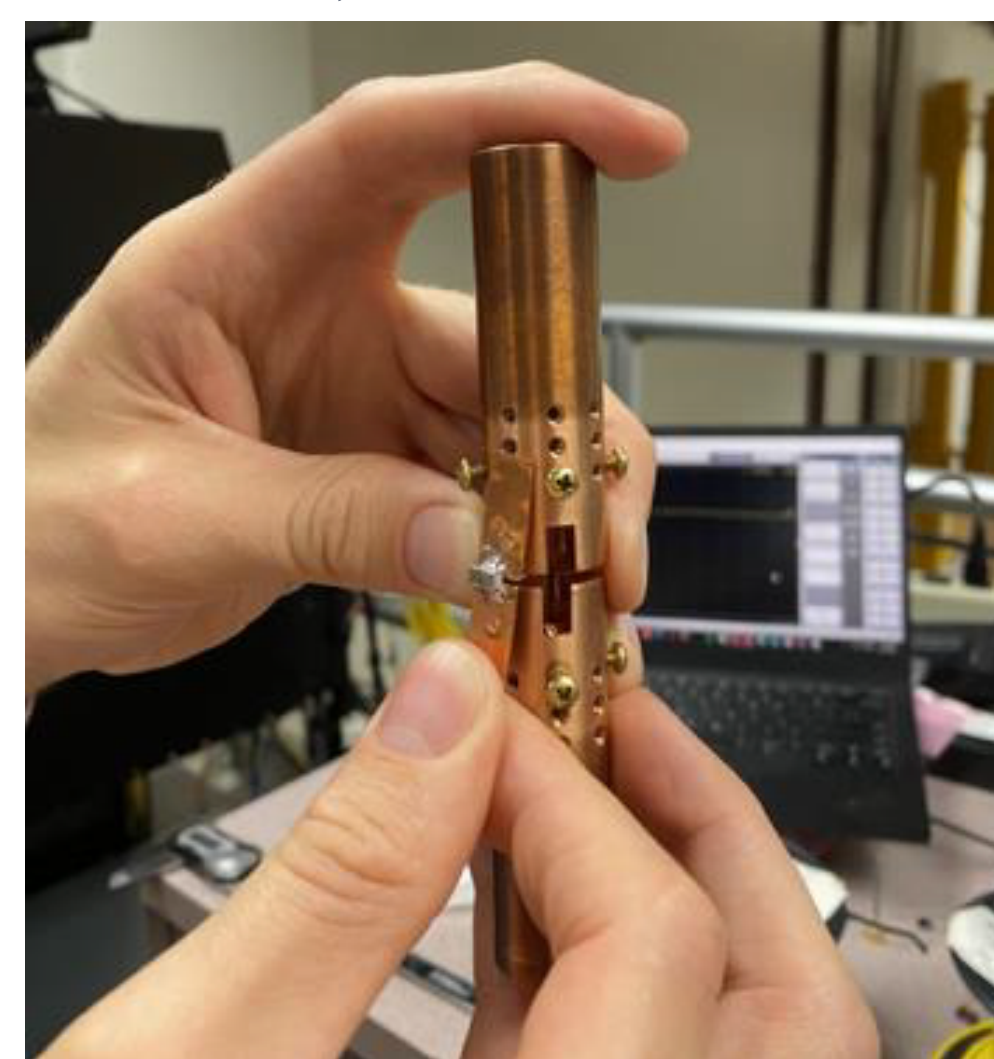

CRES-compatible NMR magnetometry for *in situ* characterization using hyper-polarized ³He

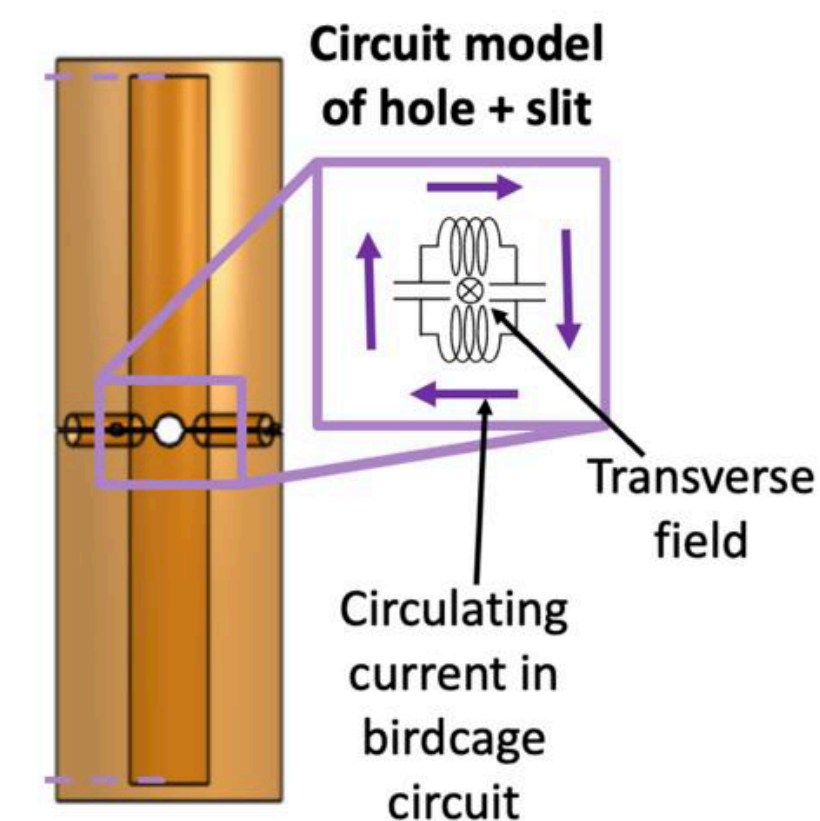

Hall probe to map the CRES trap coils



Improving Energy Resolution: Detector Design and Calibrations

PROJECT 8

Electron gun for tunable nearly mono-energetic electrons



M. Kallander



P. Kolbeck

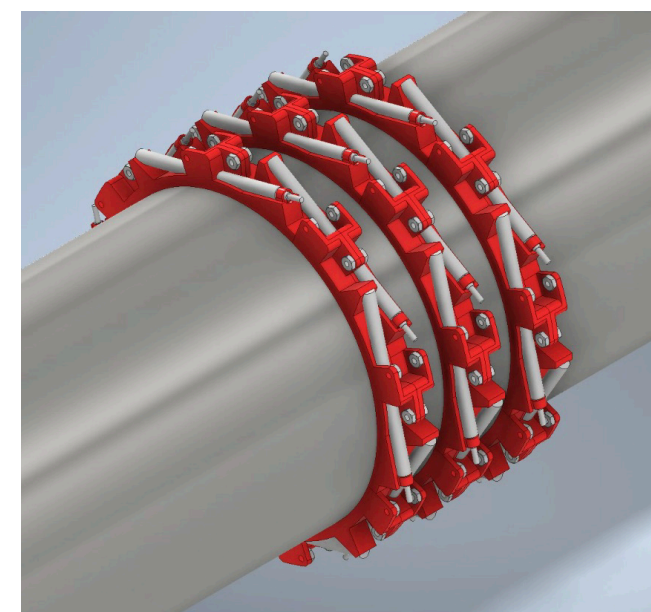

Proton NMR for magnetic field monitoring outside the cryogenic region

Developing multimode resonant cavities for improved reconstruction

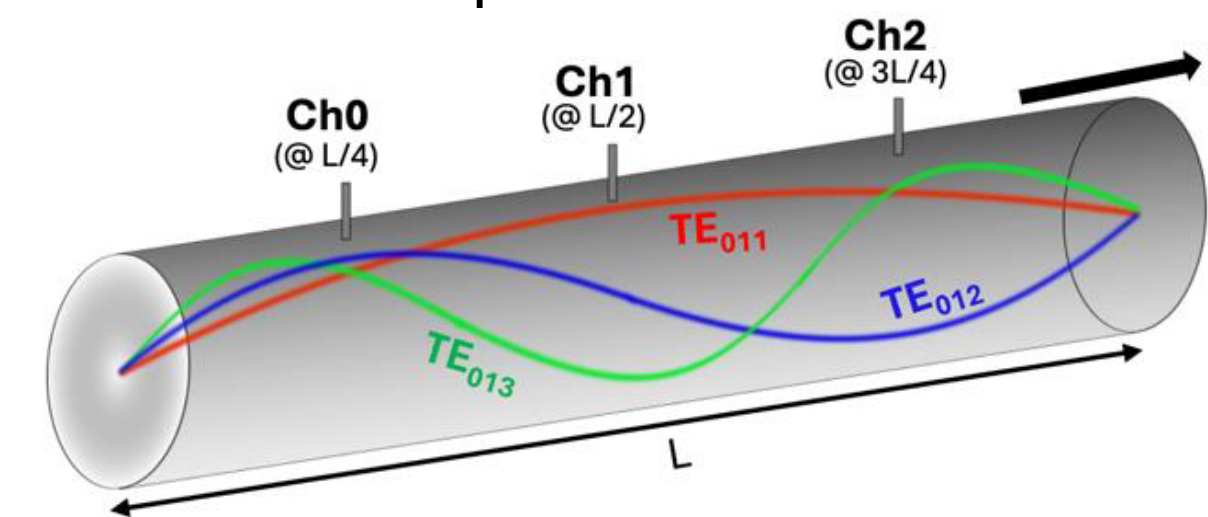

Mode filtering and readout development

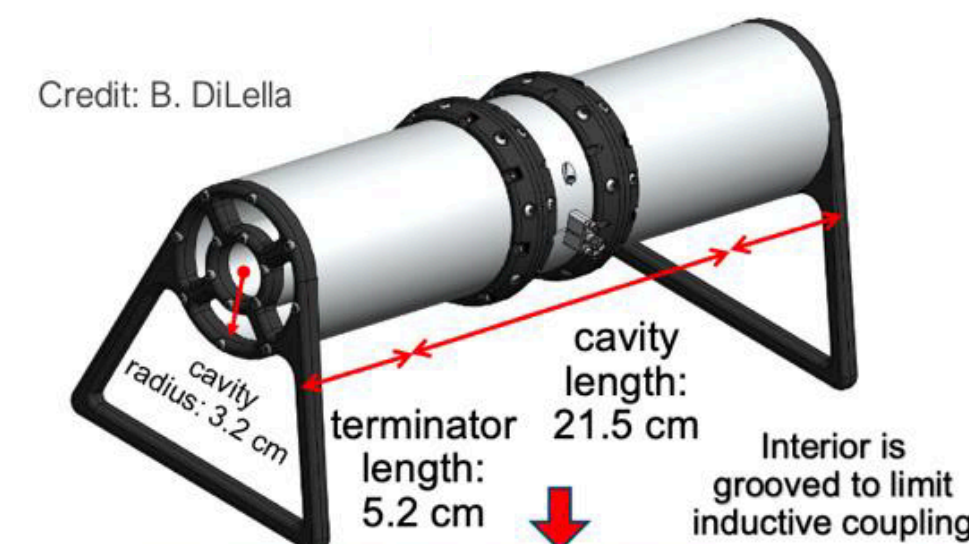

Credit: B. DiLella

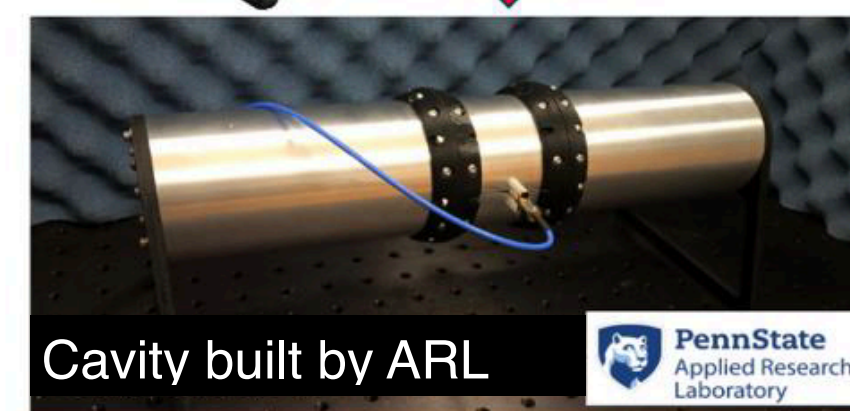

We expect 0.3 eV resolution in the CCA thanks to design, calibration, and reconstruction improvements, enabling separation of the ^{83m}Kr $\text{N}_2\text{-32}$ and $\text{N}_3\text{-32}$ lines (~ 0.67 eV)

Power vs pitch angle: Ch0 + Ch1 + Ch2 (SNR = 250)

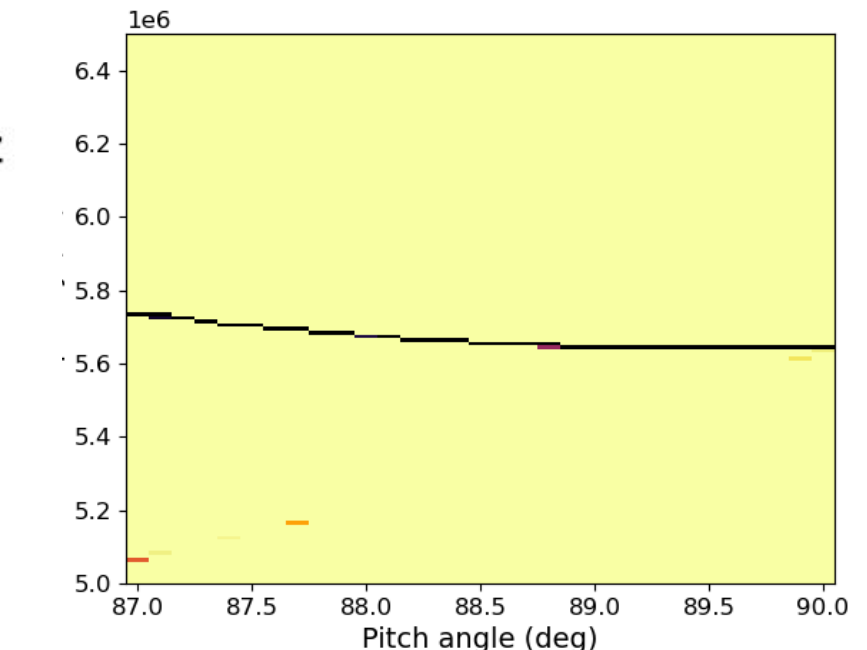

Power vs pitch angle: Ch0 - Ch2 (SNR = 250)

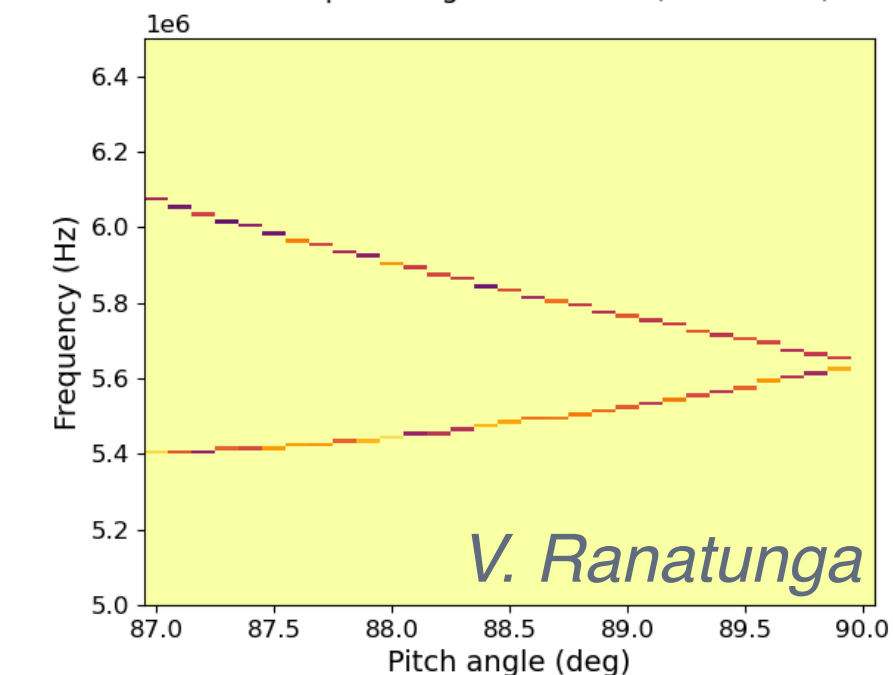

V. Ranatunga

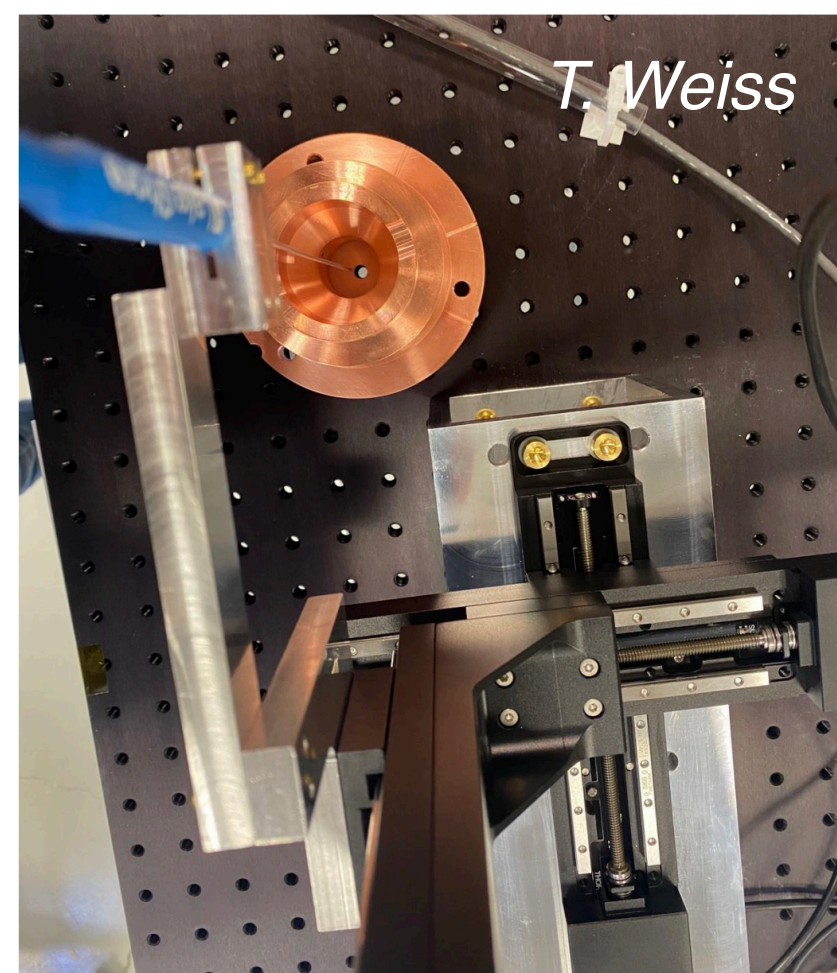

T. Weiss

Hall probe to map the CRES trap coils

A. Kurmus, S. Kuenstner

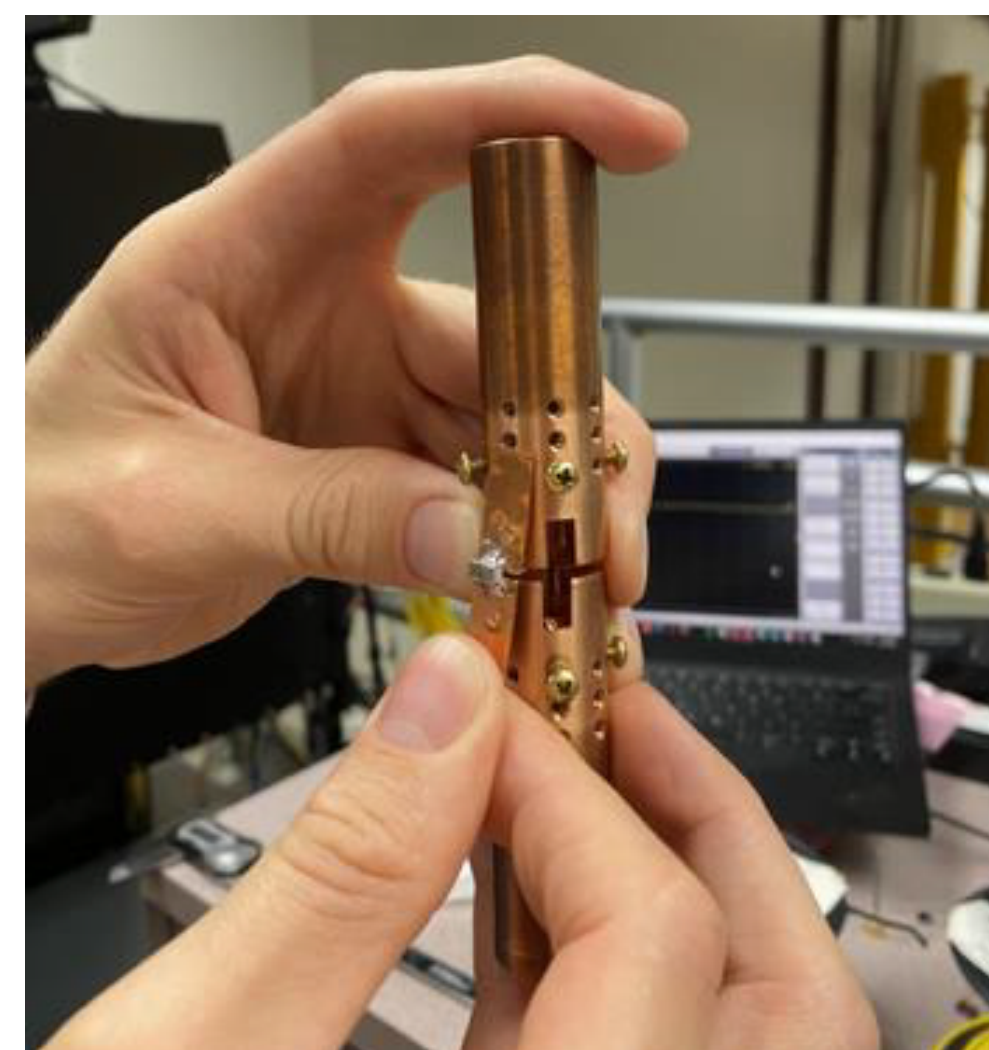

CRES-compatible NMR magnetometry for *in situ* characterization using hyper-polarized ^3He

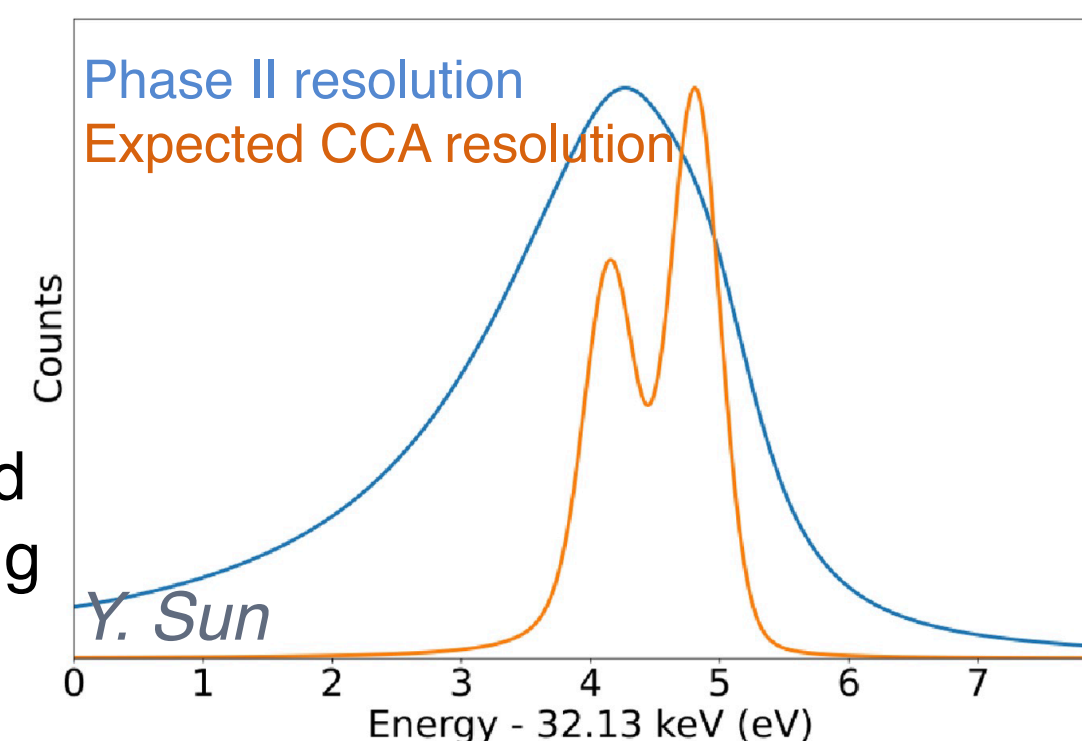
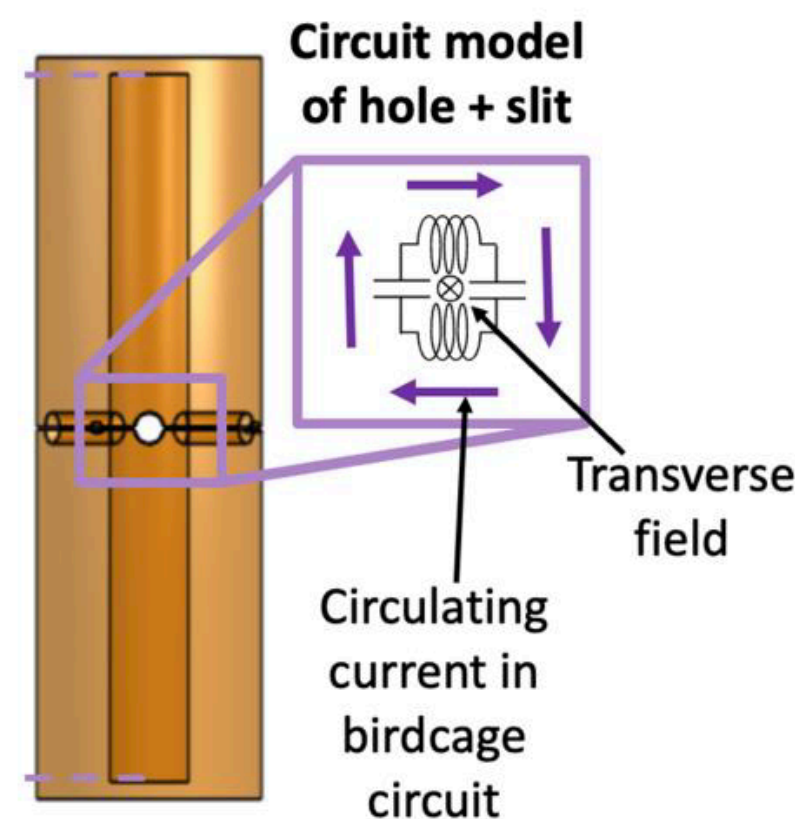

Y. Sun



Phase III

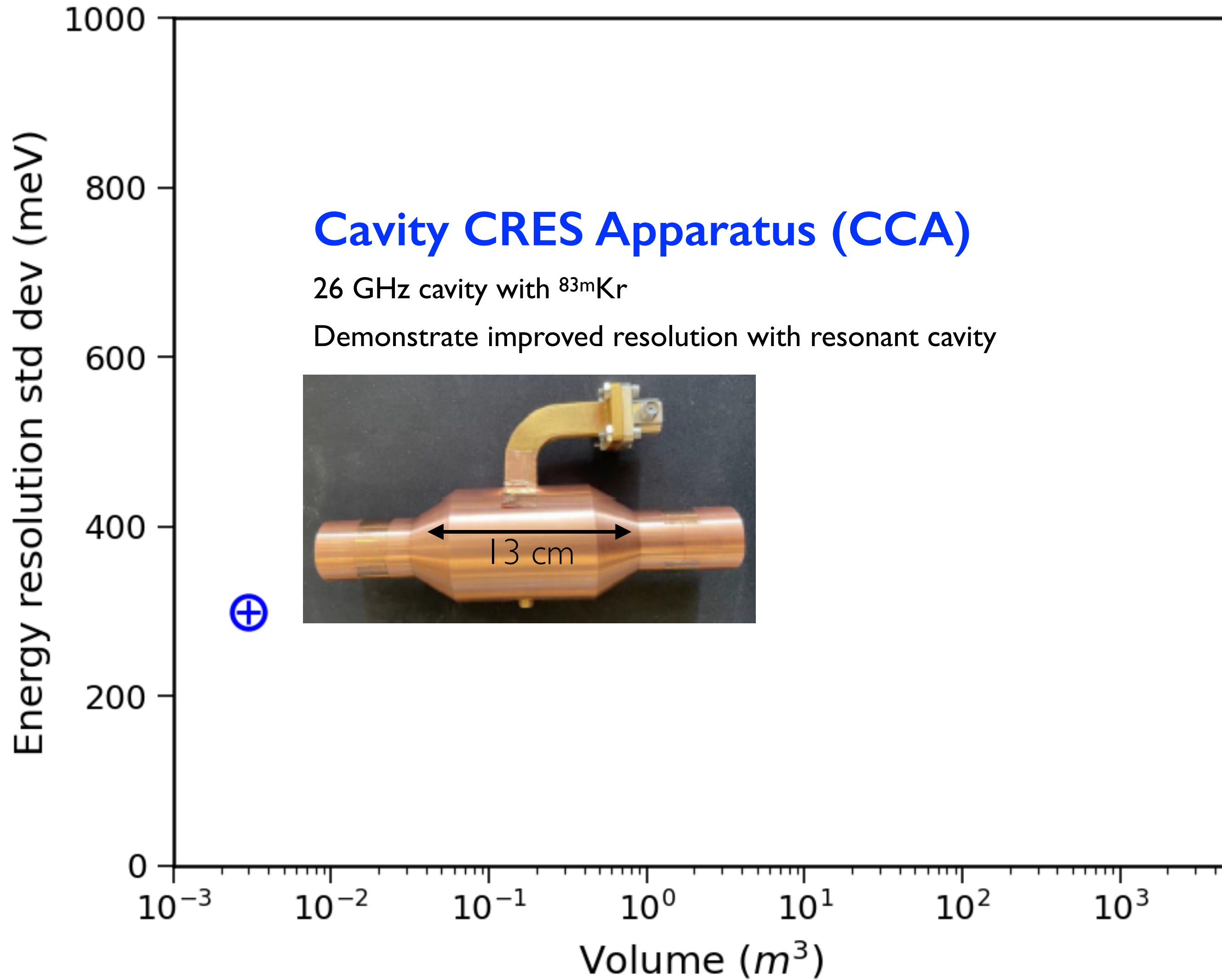



Phase III

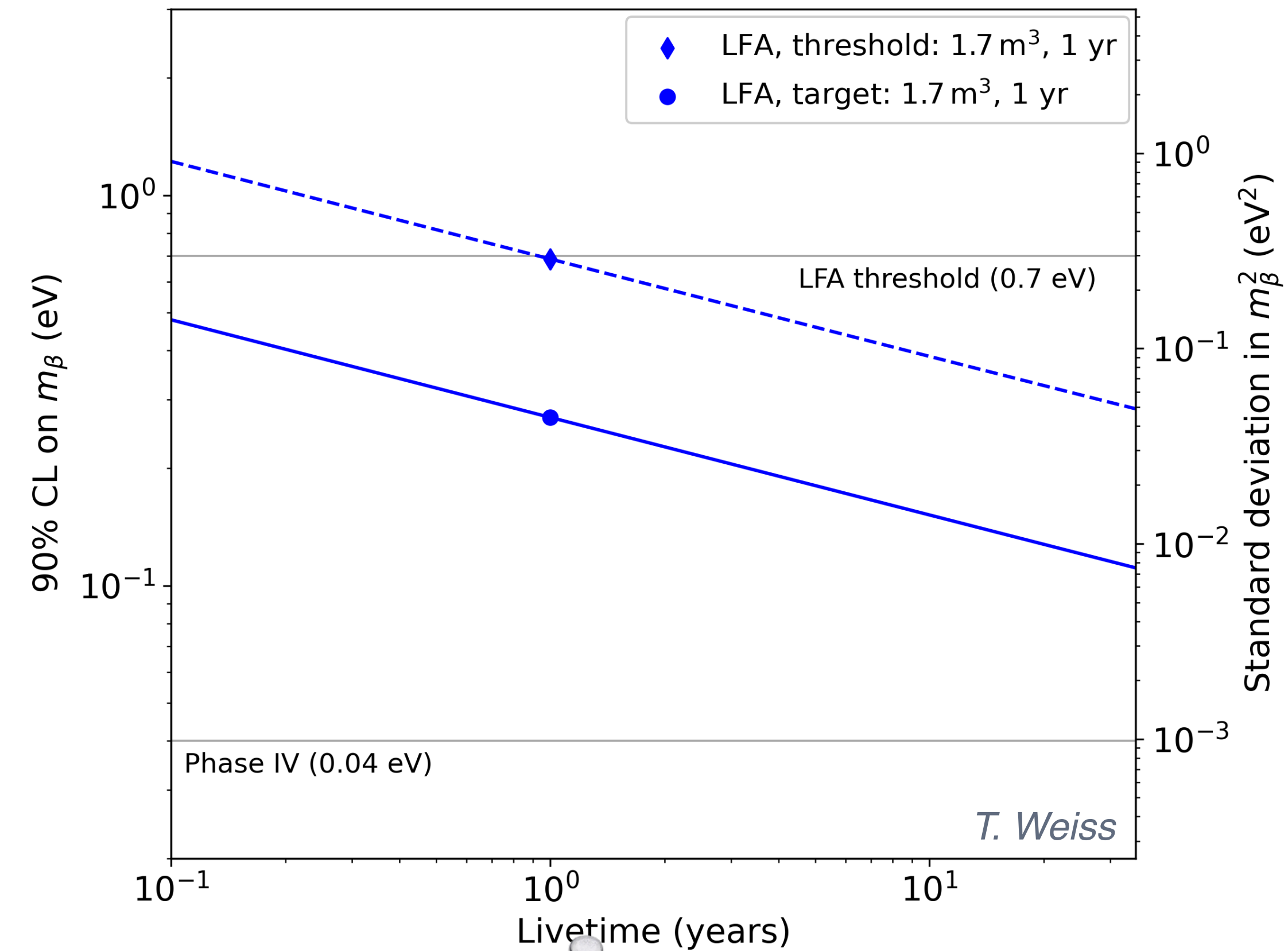
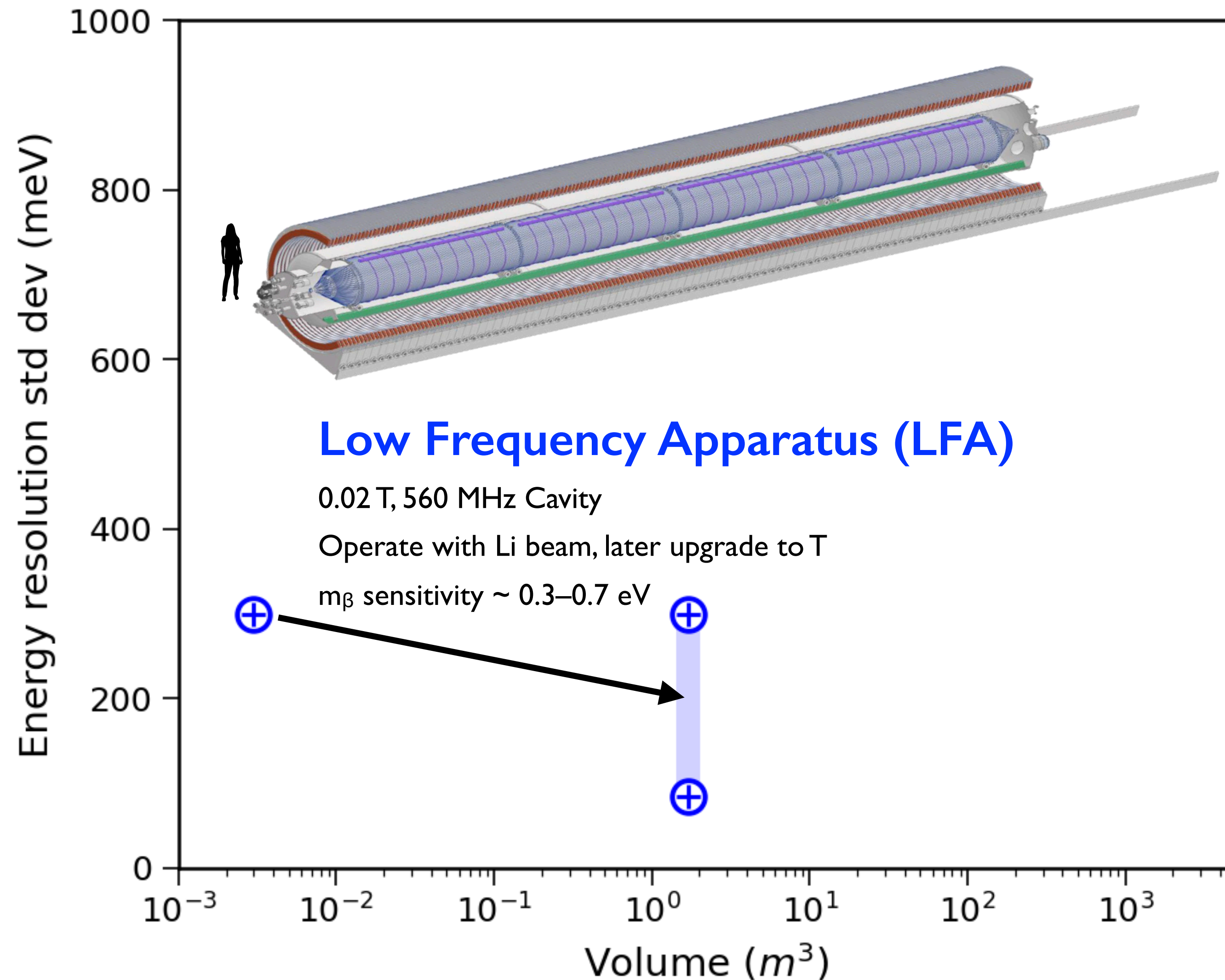

Low Frequency Apparatus for the Project 8 Experiment:
 a frontier direct kinematic neutrino mass experiment
E. Novitski, N. Oblath



Phase III

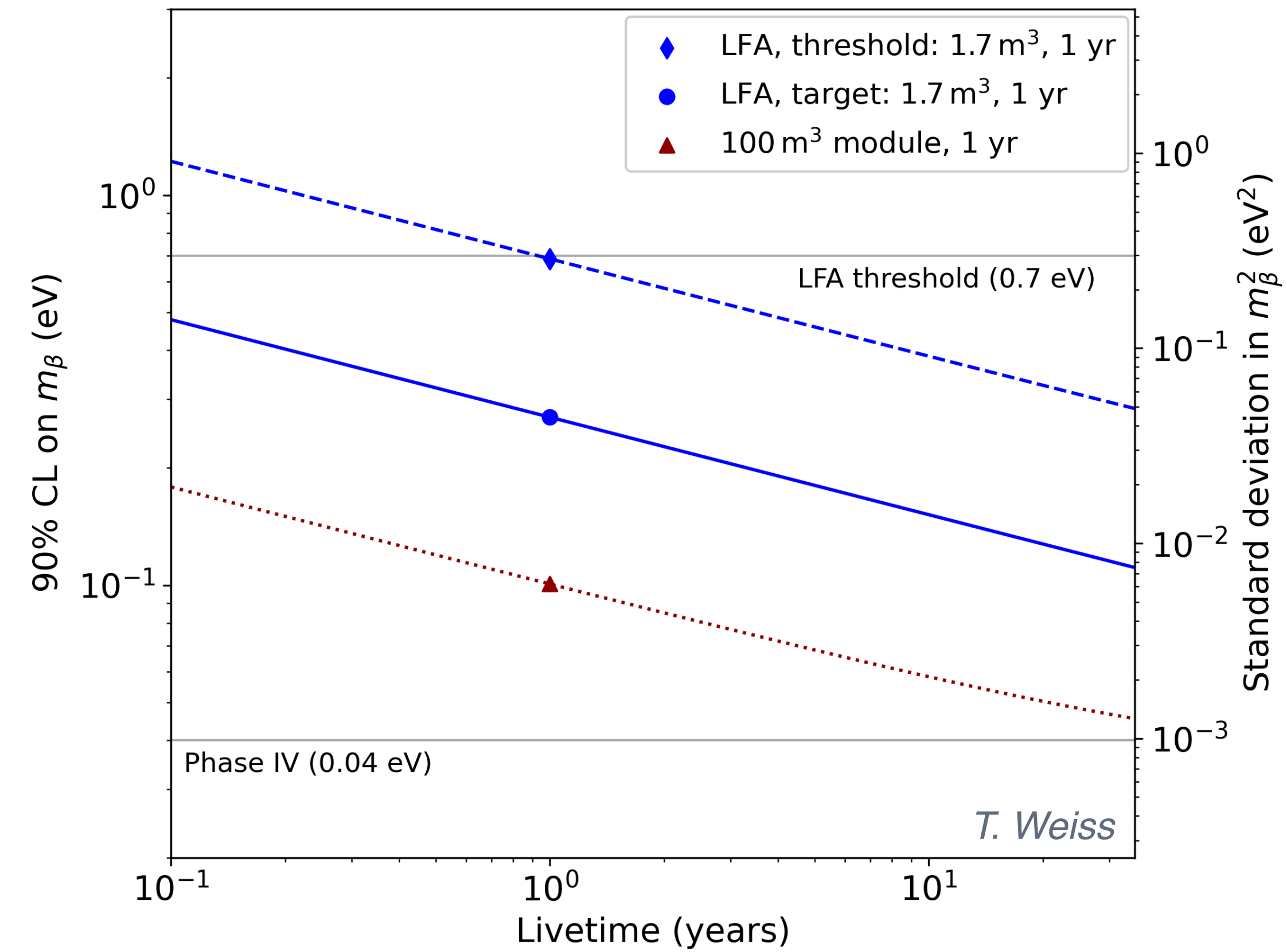
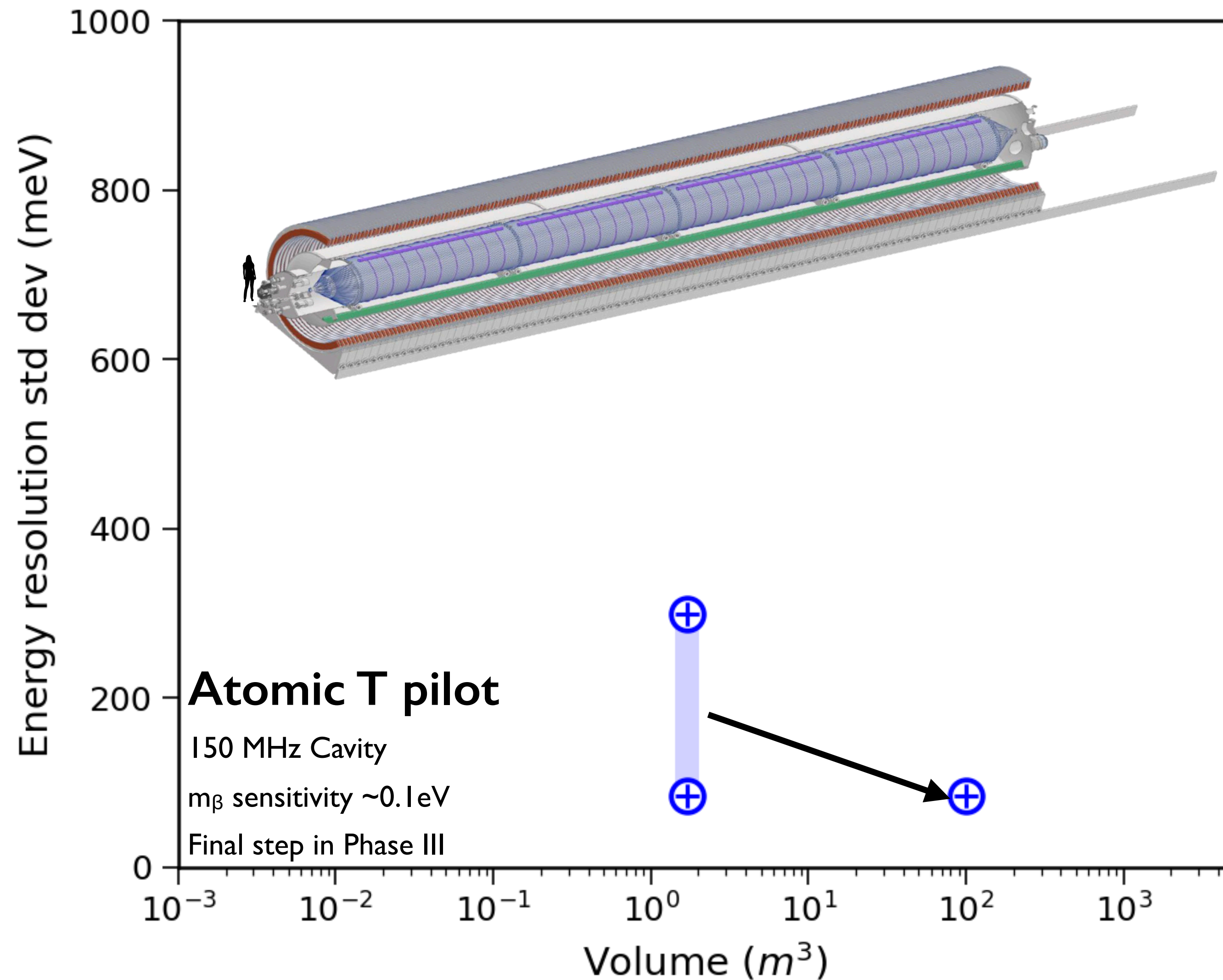



Phase IV

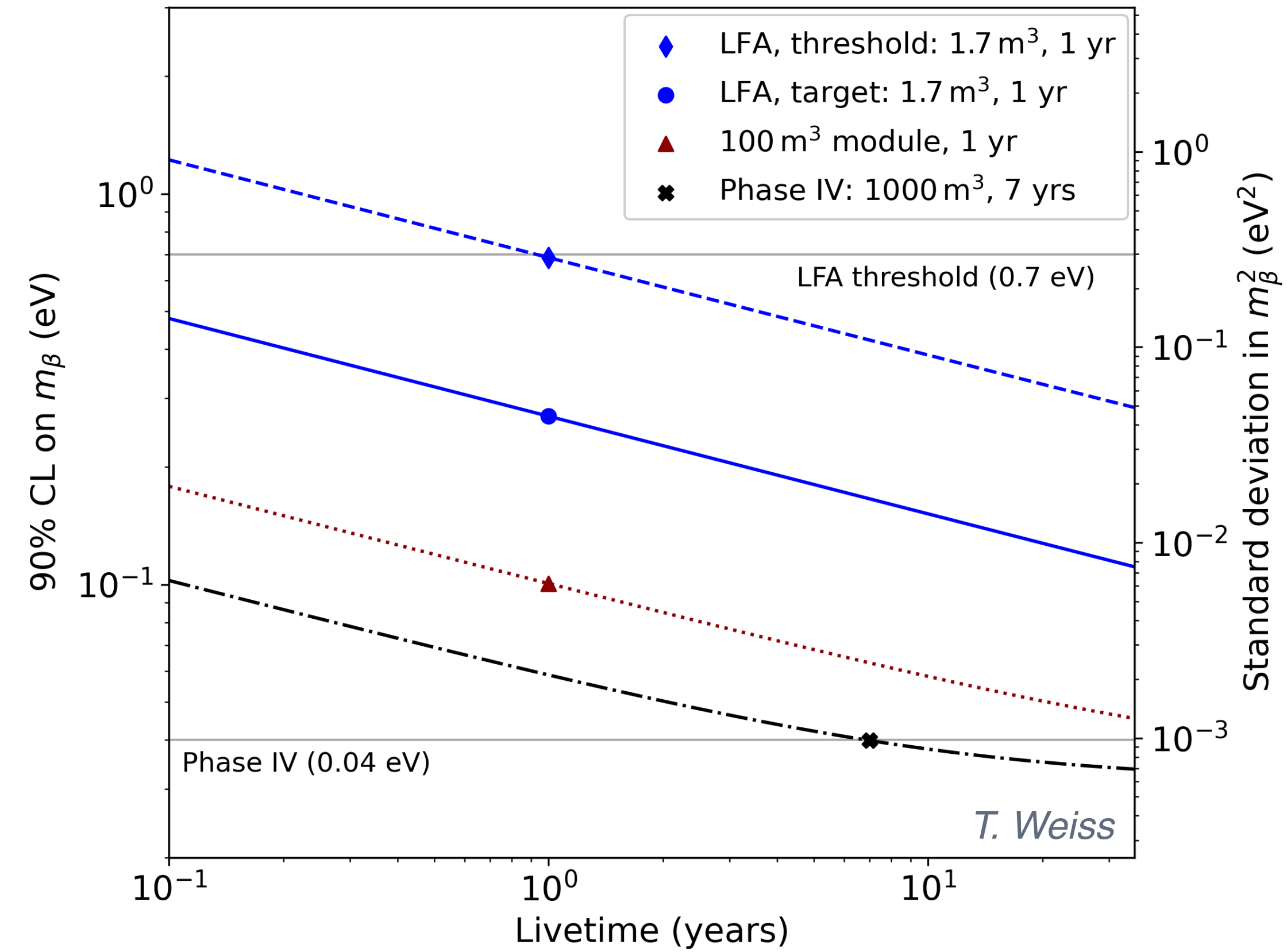
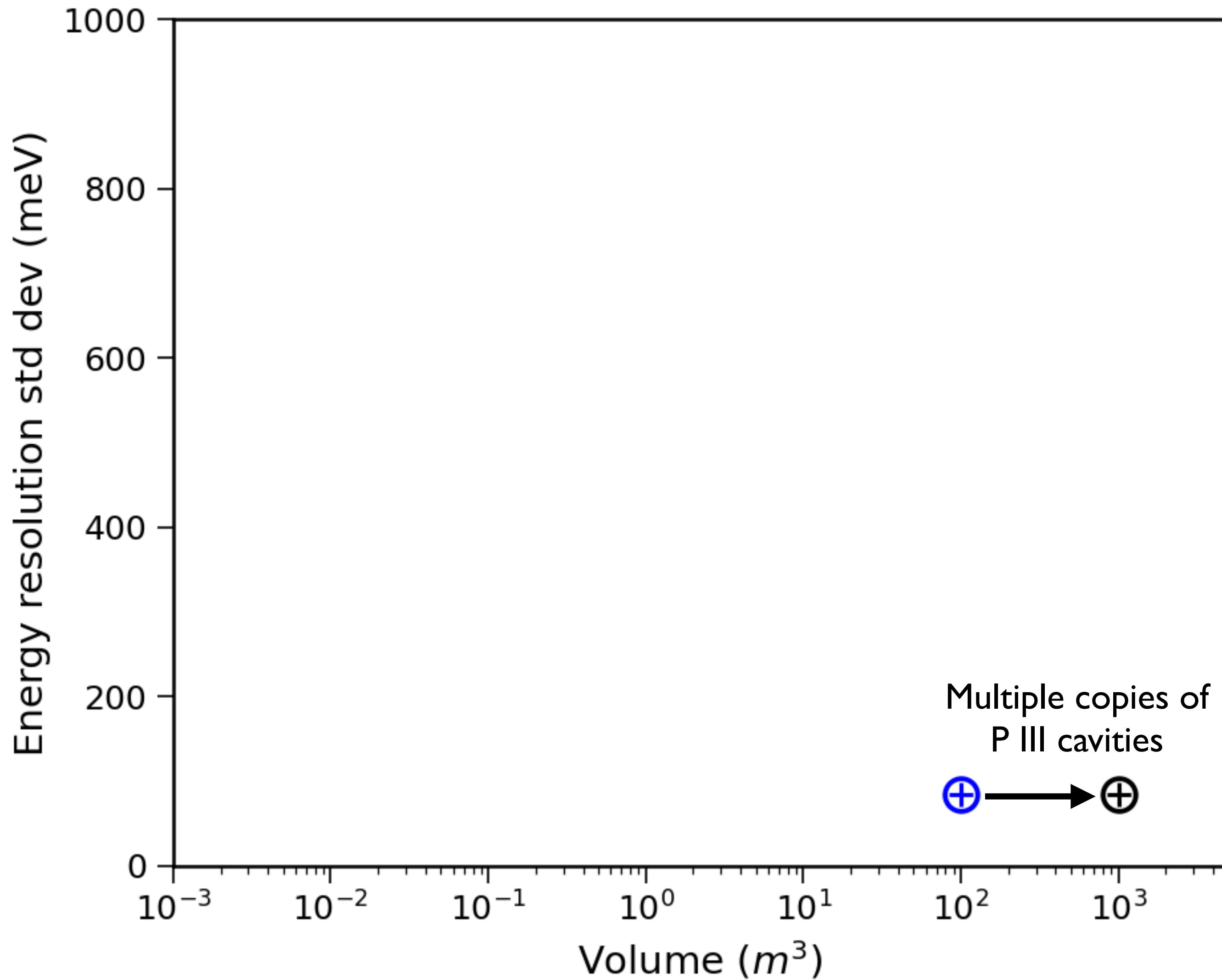



Phase IV

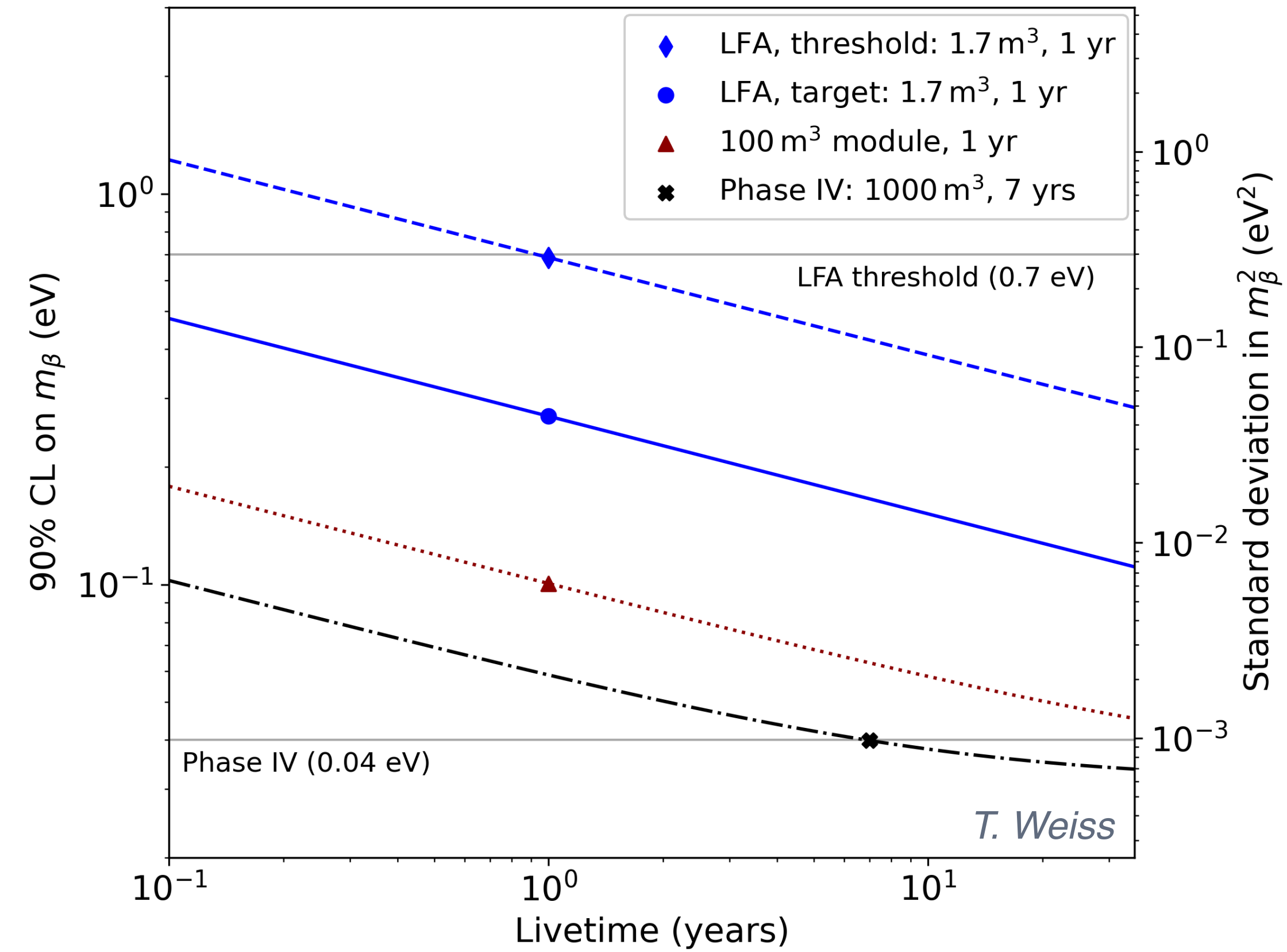
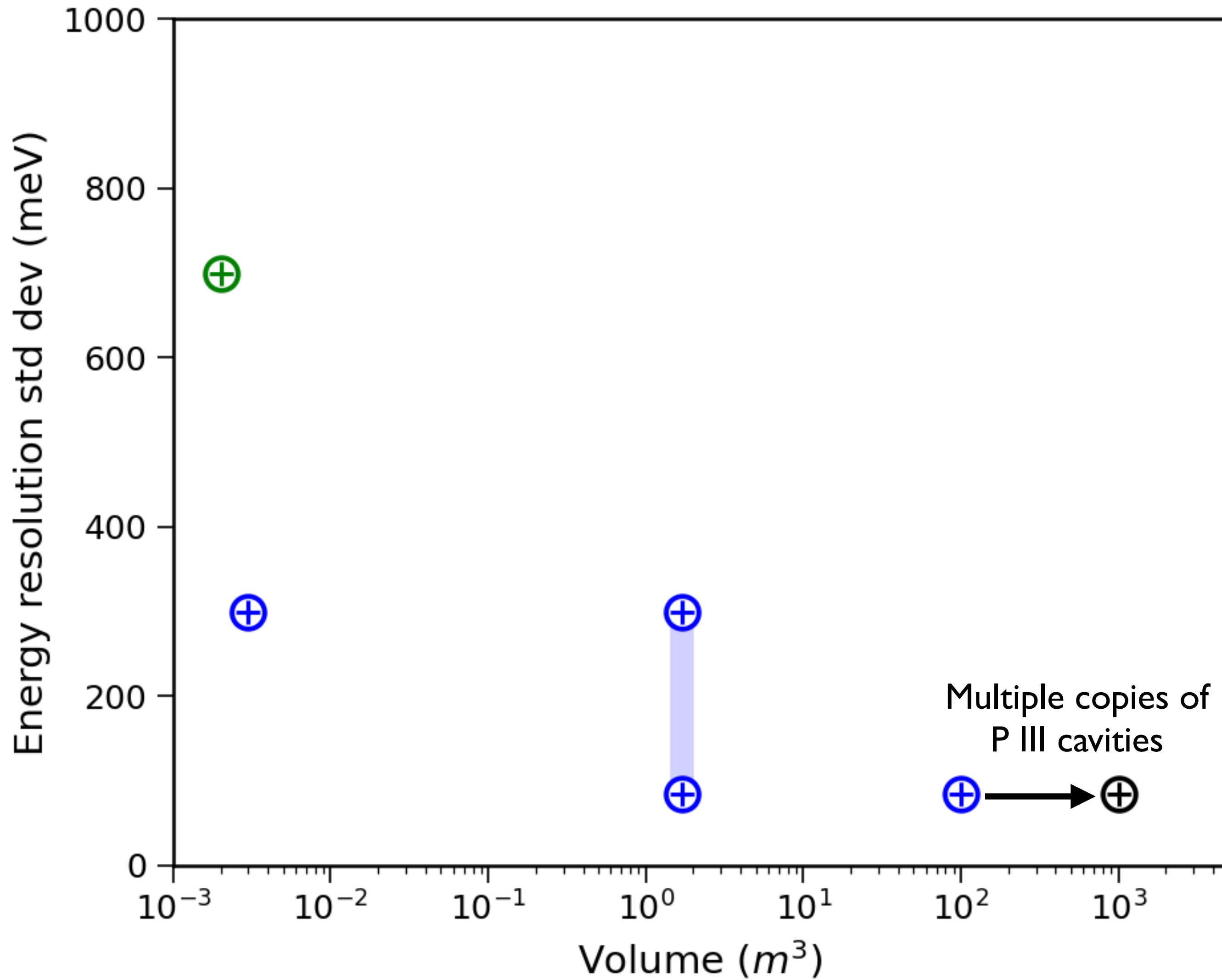



See Posters for Many More Skipped Details

Low Frequency Apparatus for the Project 8 Experiment:
a frontier direct kinematic neutrino mass experiment
E. Novitski, N. Oblath

Superconducting Readout and Parametric Amplifiers for Neutrino Mass Measurements
W. Van De Pontseele, J. Wang, Z. Disler, C. Denney

Event Reconstruction for sub-eV Energy Resolution
in the Project 8 Neutrino Mass Experiment
H. Binney, V. Sharma, J. Pena, P. Slocum

Cyclotron Radiation Signal Characterization and Noise
Modeling in Resonant Cavities for Project 8
R. Mueller, W. Van De Pontseele, M. Brandsema, L. de Viveiros

High-Flux Atomic Source for the Project 8 Neutrino Mass Experiment
W. Pettus, E. Novitski, H. Robertson, B. Foust, M. Wynne, J. Oueslati

Machine-Learning-Driven Signal Processing and Event Reconstruction
for Cyclotron Radiation Emission Spectroscopy in QTNM
N. Higginbotham

Optical Thermometry of Thermal Atomic Sources for Next-Generation Neutrino Mass
Measurements
B. Mucogllava, M. Röllig, M. Fertil

Towards High-Resolution Spectroscopy of Low-Energy Electrons with
Transition-Edge Sensors in the PTOLEMY Experiment
Benedetta Corcione

Determination of the Atomic Fraction in Intense Hydrogen Beams for Future Neutrino
Mass Experiments
A. El Boustani, C. Rodenbeck, M. Schlösser, S. Böser



The Path Forward for Direct Neutrino Mass Experiments

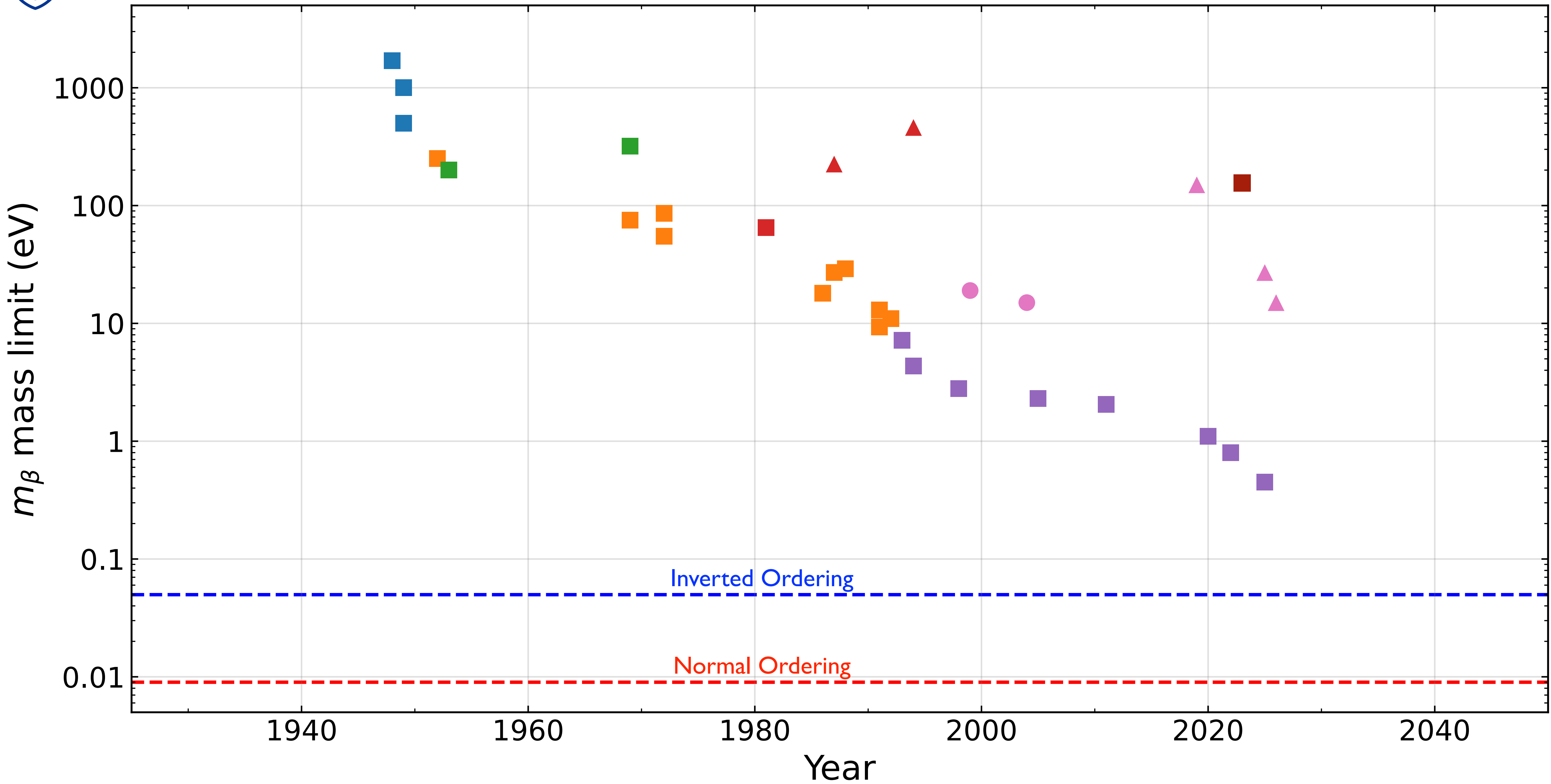



The Path Forward for Direct Neutrino Mass Experiments

