

Seung Mok Lee
#82
D₂O/H₂O
deployment

Vinicius Da Silva
#115
Argon CC in
CENNS-750

Natalie Jones
#175
Metal sandwich
(CC)

Eli Ward
#179
D₂O analysis

Ana Zaalishvili
#207
NEP-ton: Pb CC

Joshua Queen
#268
Argon CC in
CENNS-10

Jane O'Reilly
#292
NalVETE: CEvNS
on NaI

Ryan Bouabid
#367
GeMini analysis
campaign 3

Isabel Colón
Rivera
#440
CEvNS on Neon

Nick Meredith
#455
GeMini analysis
campaign 2

Tyler Johnson
#275
NuThor:
neutrino-
induced fission

Lingquan Kong
#183
CryoCsI

Emma van
Nieuwenhuizen
#416
Form factors w/
Ge data

The COHERENT collaboration:

Precision neutrino-nucleus scattering at the SNS

Sam Hedges, Virginia Tech - June 22nd, 2026



First detection of CEvNS

Origins of COHERENT

- Formed in 2013 to measure Coherent Elastic Neutrino-Nucleus Scattering (CEvNS) at the Spallation Neutron Source (SNS) at Oak Ridge National Laboratory
- **CEvNS physics goals:**
 - Make first measurement of CEvNS
 - Study CEvNS interaction with different targets
 - Measure Standard Model parameters (electroweak physics, nuclear physics), and explore CEvNS as a probe of NSI physics
- **Approach:**
 - Multiple detector technologies and targets to reduce systematic uncertainties
 - Share knowledge & techniques to characterize backgrounds, neutrino source

Neutrino production at the SNS

- 1.3 GeV protons strike a mercury target at 60 Hz
 - ~350ns FWHM
 - Leads to unique prompt and delayed neutrino timing signature
- **SNS recently reached 2 MW power!**
 - $\sim 3.5 \times 10^{15}$ neutrinos/second
- Simulated incorporates small fraction of pions that decay in flight

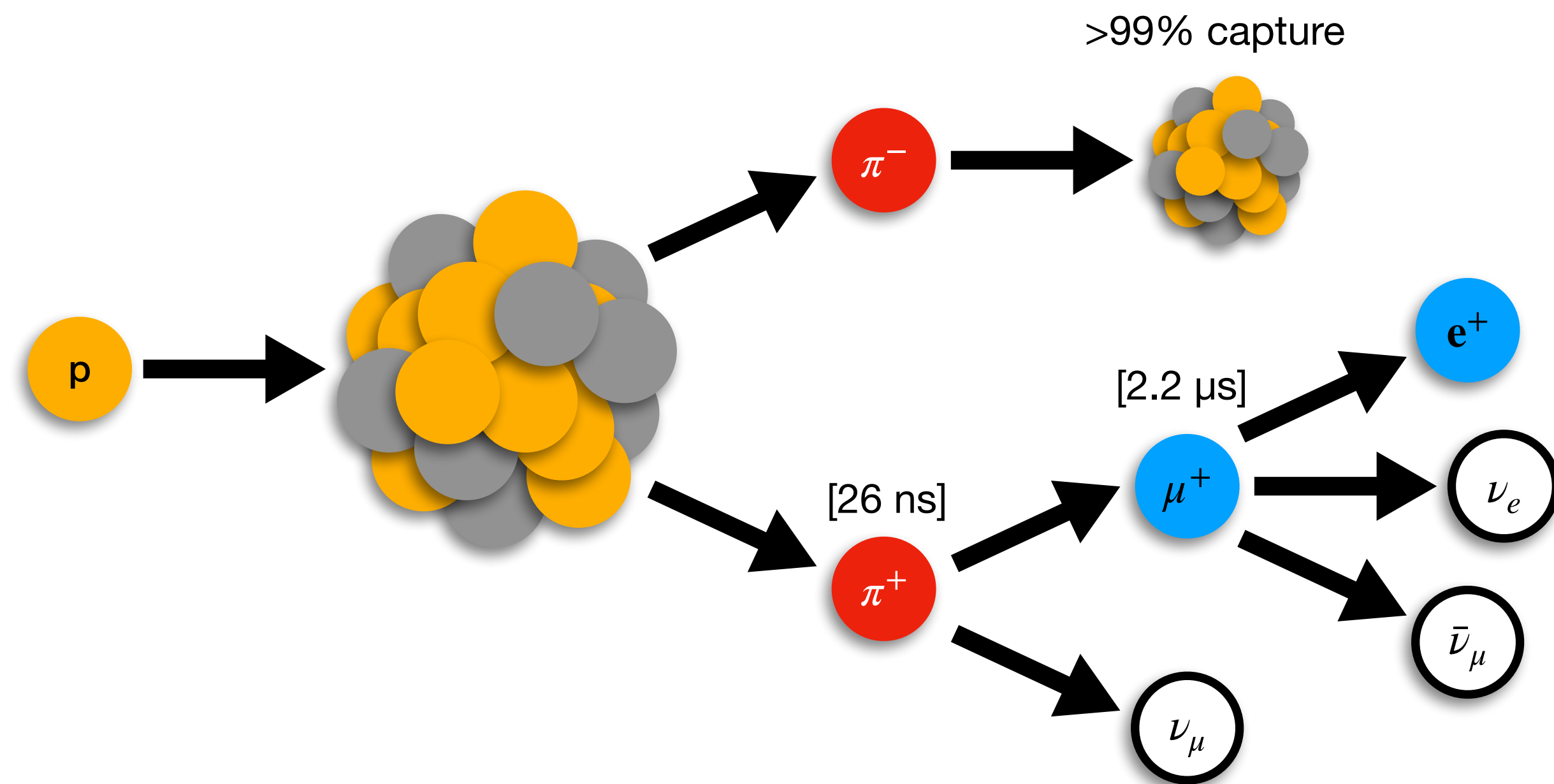

SNS neutrinos

Simulated neutrino timing spectrum

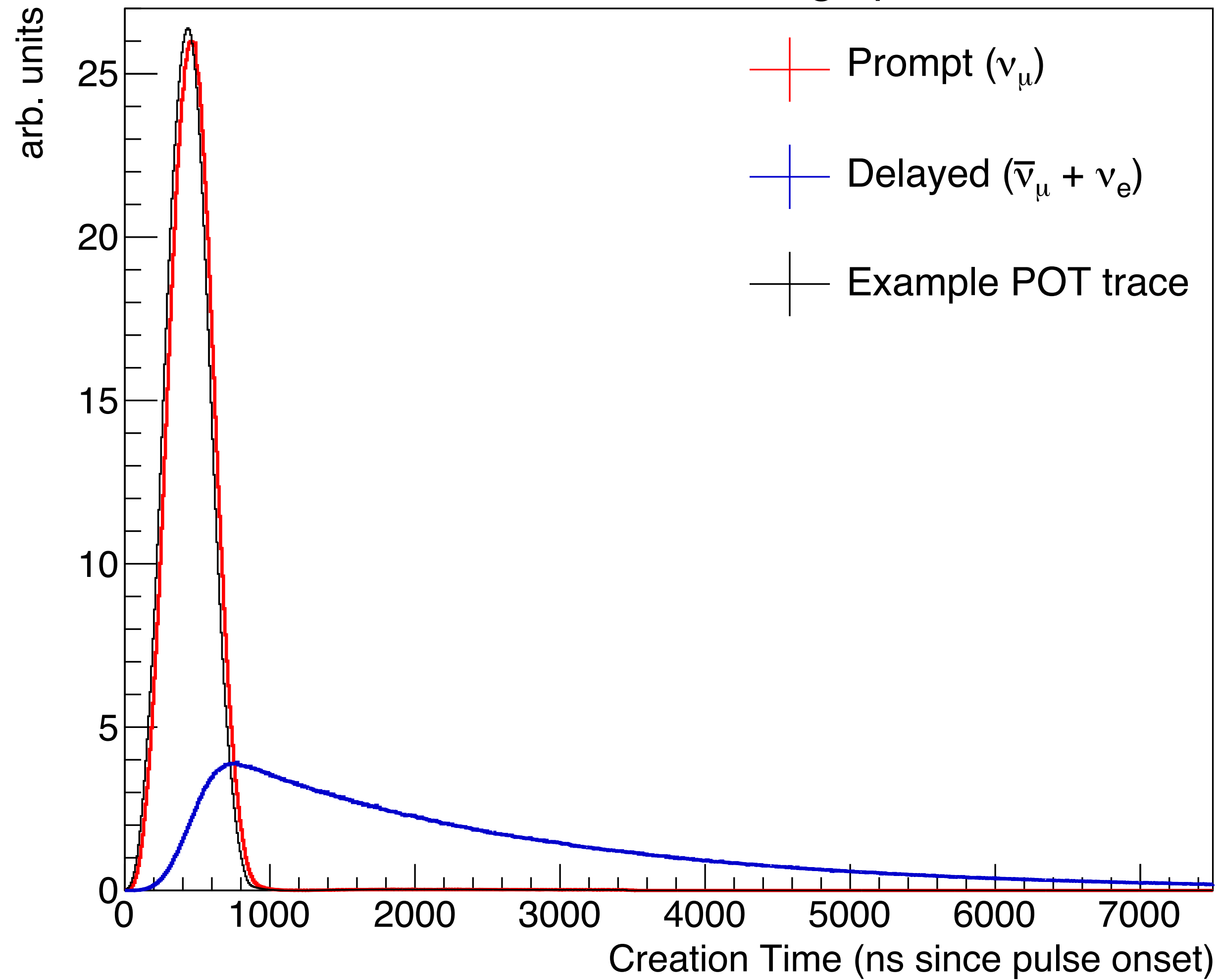

Simulated neutrino energy spectrum

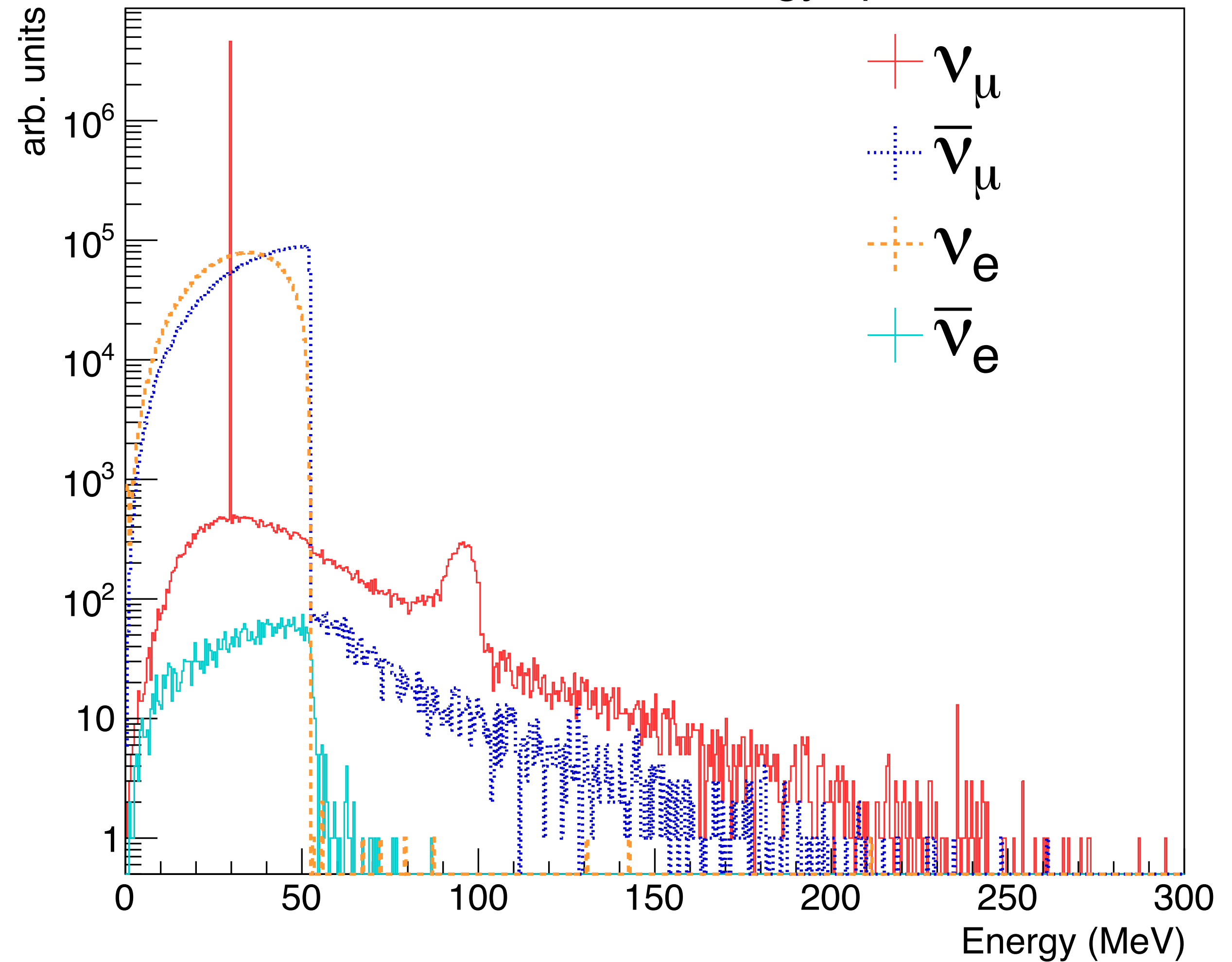

D. Akimov, et al., COHERENT, *Phys. Rev. D* **106**, 032003 (2022)

Comparison of pion decay-at-rest sources

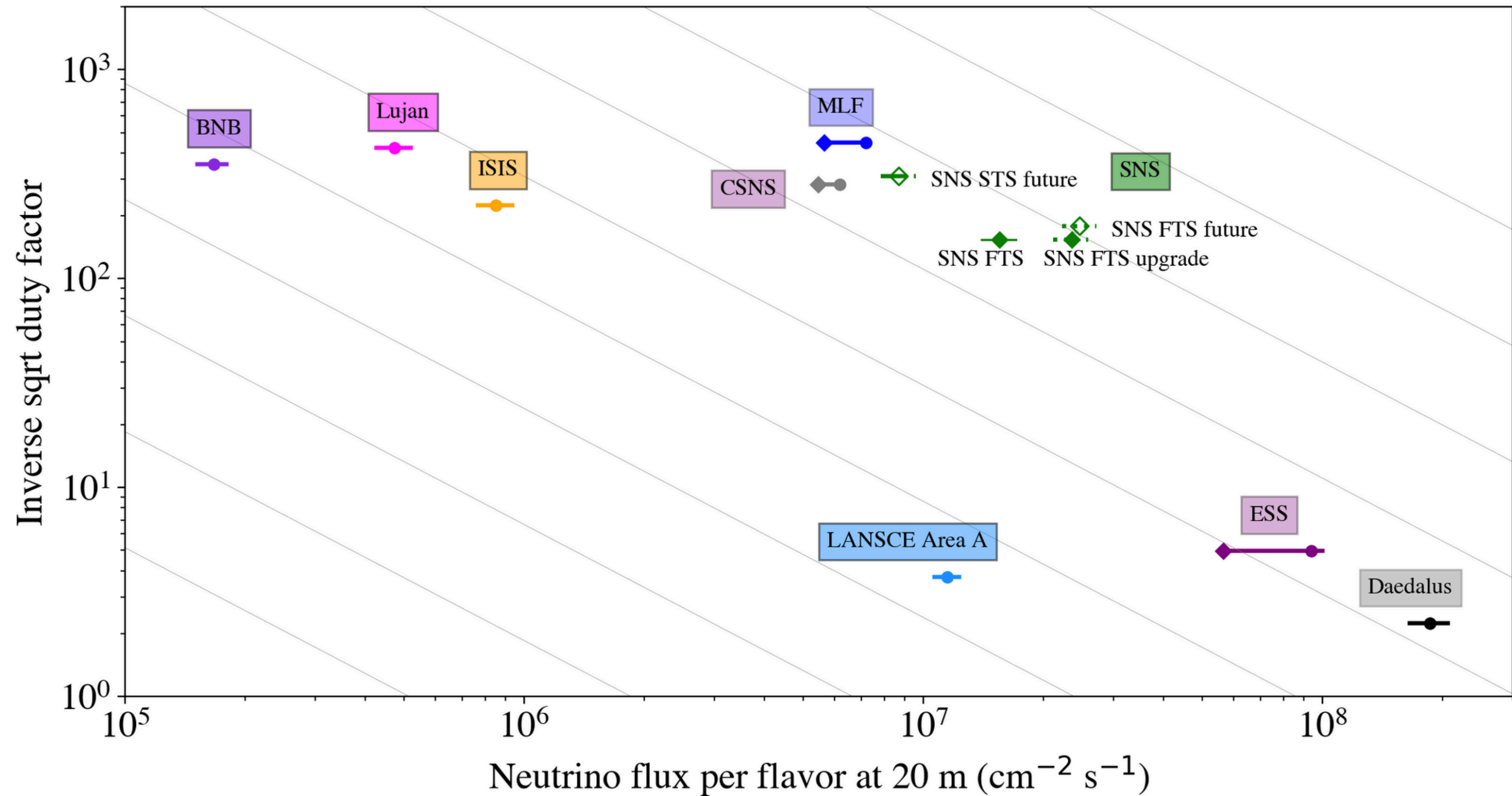

M. Adhikari, et al., COHERENT, *arXiv:2602.15652* (2026)

Backgrounds campaign

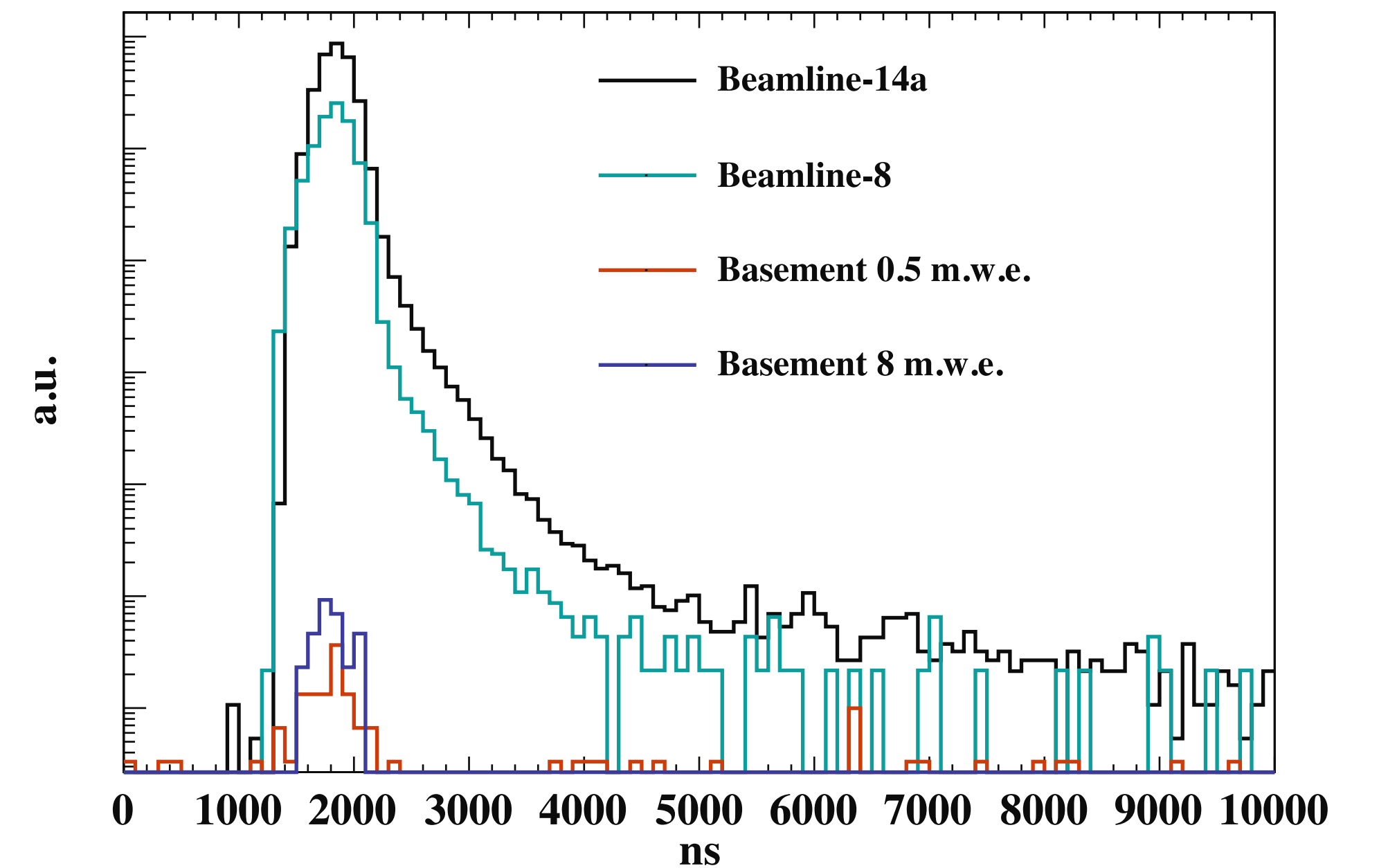
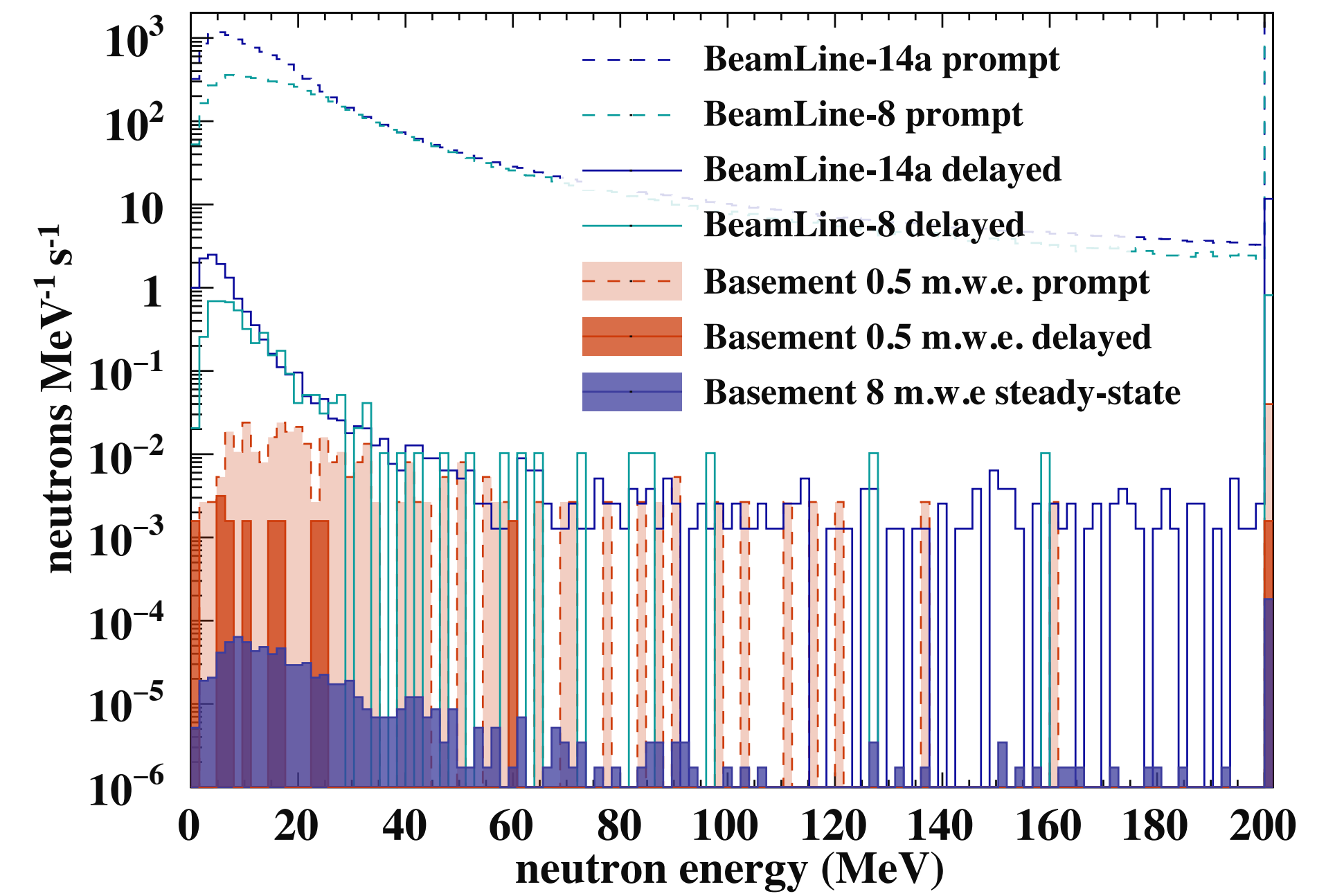

D. Akimov, et al., COHERENT, *arXiv:1509.08702* (2015)

“Neutrino Alley”

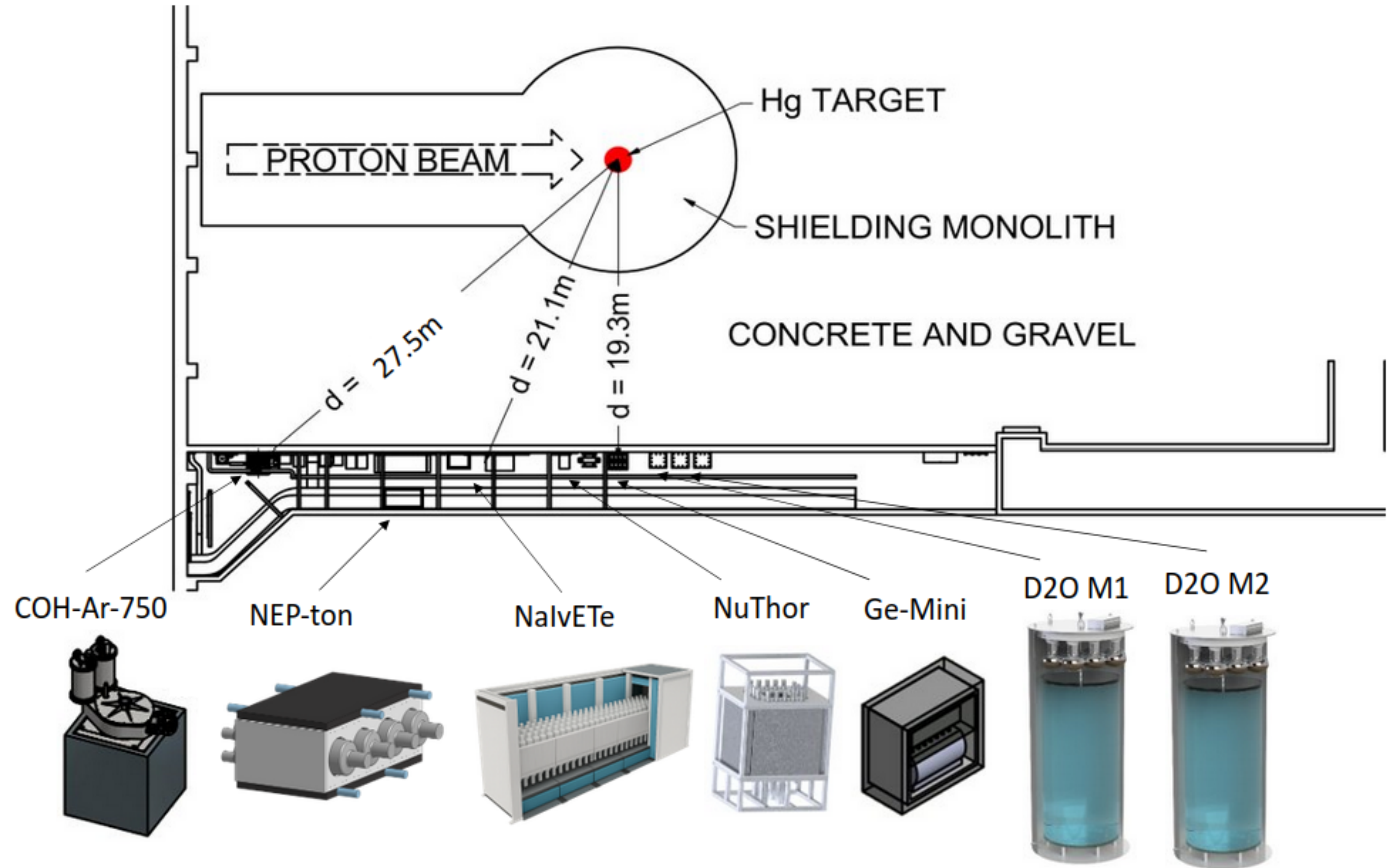

M. Adhikari, et al., COHERENT, *arXiv:2602.15652* (2026)

First detection of CEvNS

- First measurement reported in 2017
 - 14.6-kg CsI scintillator
 - 308-day exposure
 - 134 ± 22 events observed
- 2D energy and timing fit rejects null hypothesis at 6.7σ significance

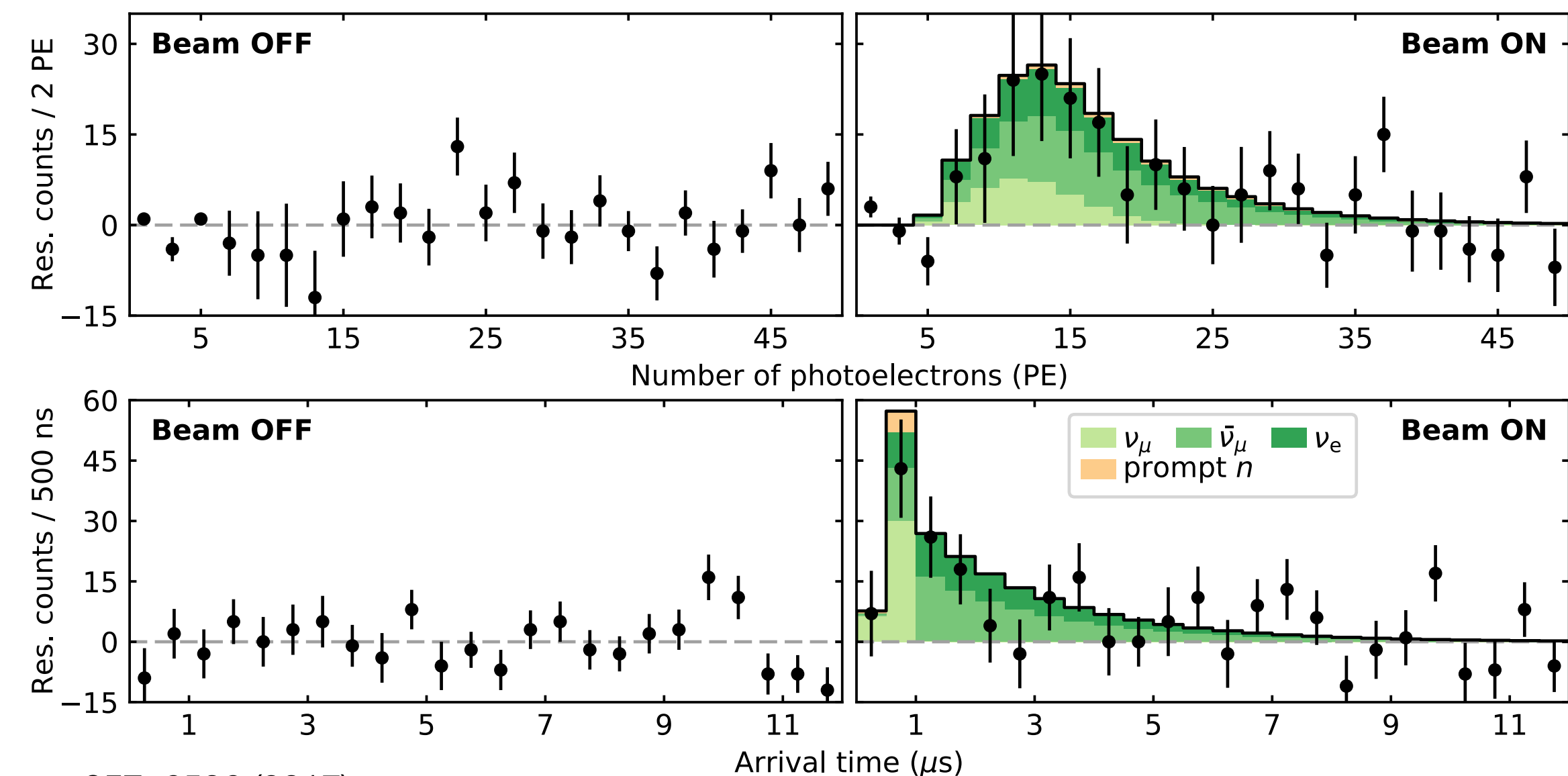
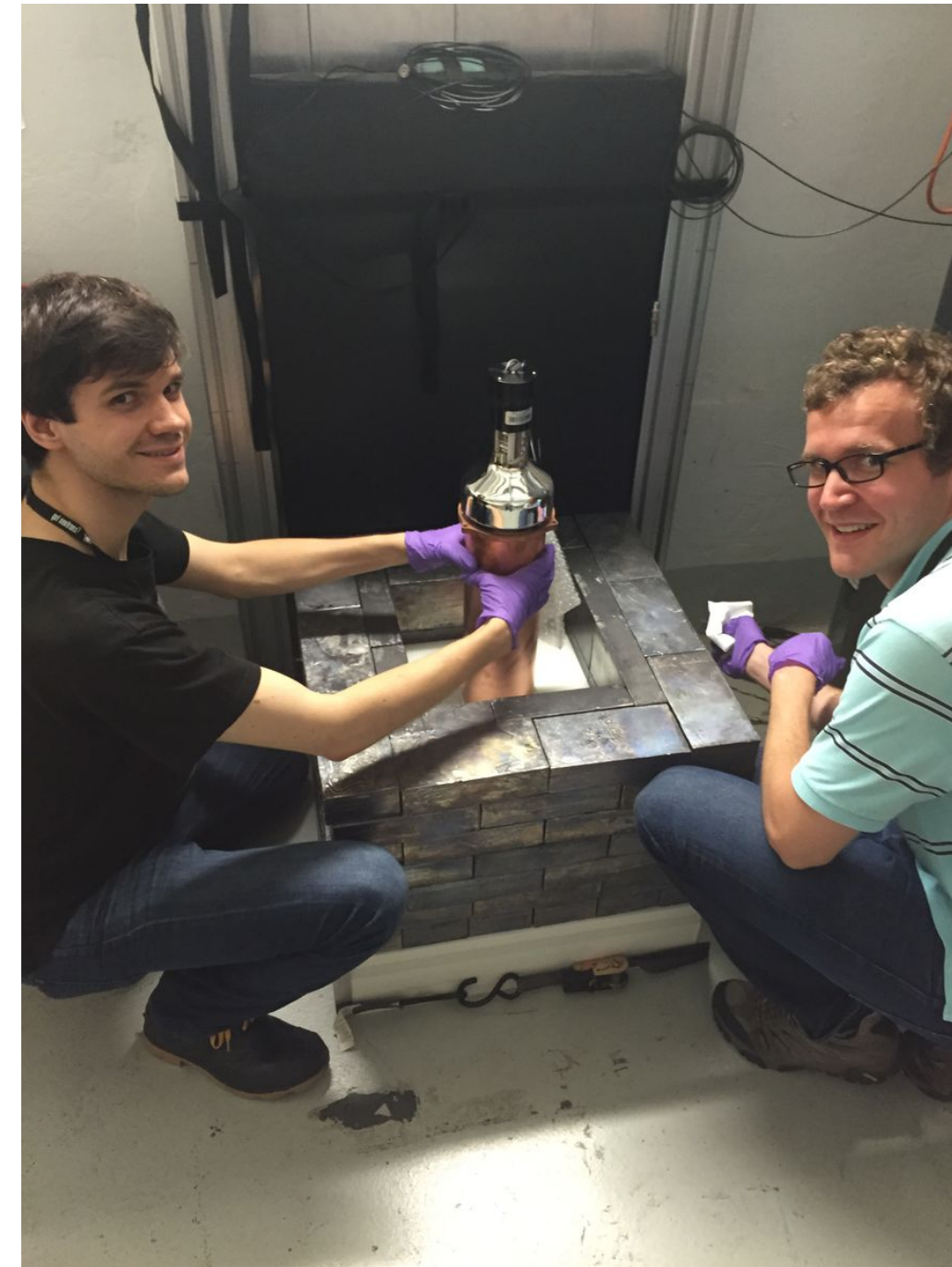

D. Akimov, et al., COHERENT, *Science* **357**, 6536 (2017)

Unfolding the CEvNS recoil spectrum

$$\frac{dN_{\text{obs}}}{dE_{ee}} = \left[N_{\text{targets}} \int dE_{\nu} \frac{d\Phi}{dE_{\nu}} \frac{d\sigma}{dE_{NR}} \right] \otimes \mathcal{R}(E_{NR}, E_{ee}) + \frac{dN_{\text{bkg}}}{dE_{ee}}$$

$$\frac{d\sigma}{dE_{NR}} \approx \frac{G_F^2 M}{8\pi} [Z(1 - 4\sin^2\theta_W) - N]^2 \left[1 + \left(1 - \frac{E_{NR}}{E_{\nu}} \right)^2 - \frac{ME_{NR}}{E_{\nu}^2} \right] F(E_{NR})^2 + \text{axial} + \text{NSI}$$

- Electroweak physics
- Nuclear physics
- NSI contributions
- Neutrino source + oscillations
- Detector effects
- Backgrounds

Towards precision CEvNS measurements

The COHERENT CEvNS program

- Multiple targets: **CsI, Ar, Ge, NaI**
 - N^2 -dependence, form factors, vector/axial contributions
 - Systematics can cancel with multiple targets
- Towards precision measurements:
 - **Increased statistics** — larger detectors, lower thresholds
 - **Refined analyses** — new techniques, ML to reduce backgrounds
 - **Reduce systematics** — dominant systematic is neutrino flux normalization

CsI: Full dataset

- Improvements:
 - Full data set with **~2x statistics**
 - Quenching factor campaign at TUNL to **reduce systematic uncertainties**
 - Re-optimization of event selection cuts
- Disfavors null hypothesis at 11.6σ
- Recent re-analysis by Chenguang Su, lowering threshold and reducing backgrounds — **coming soon!**

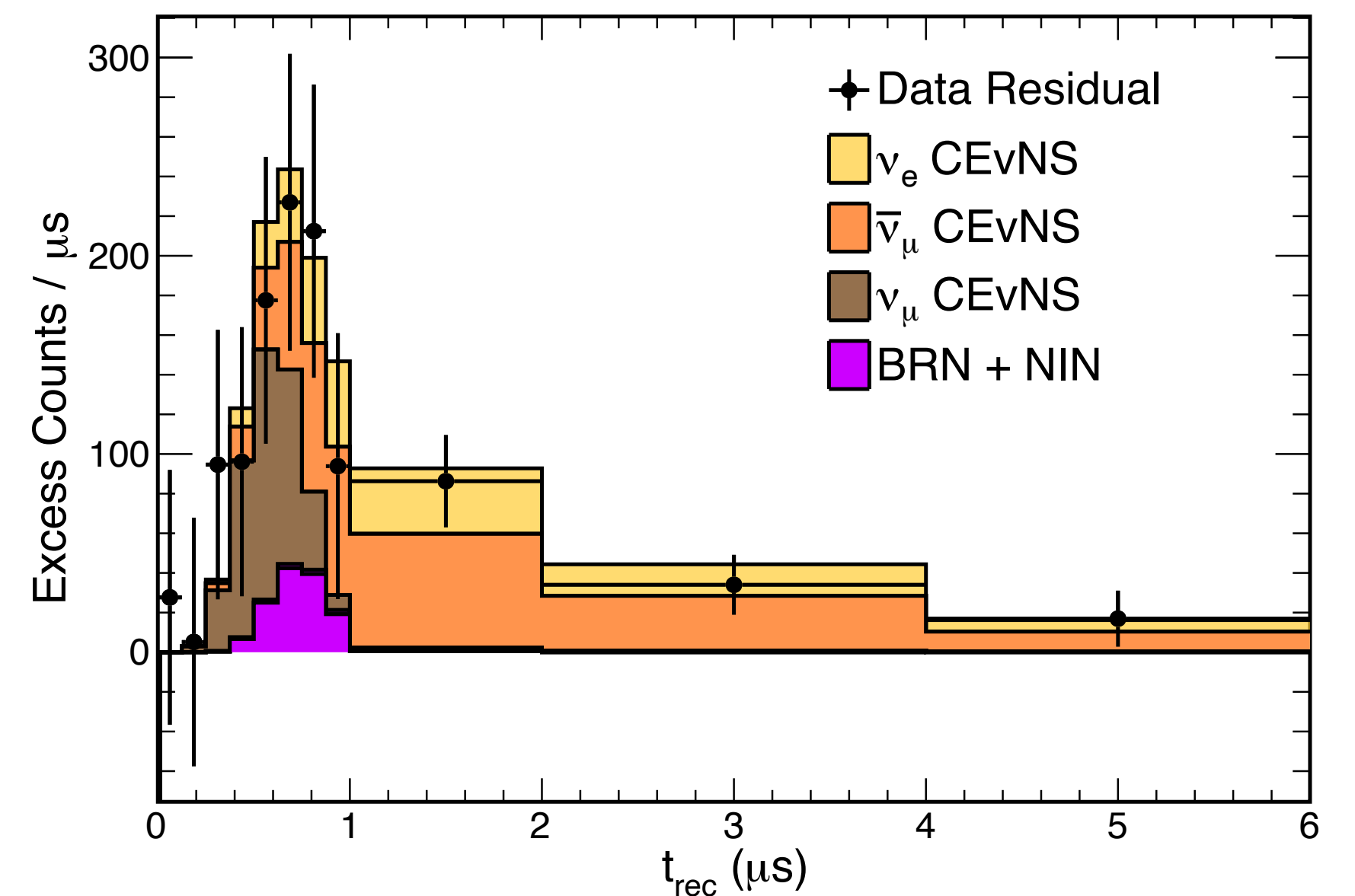
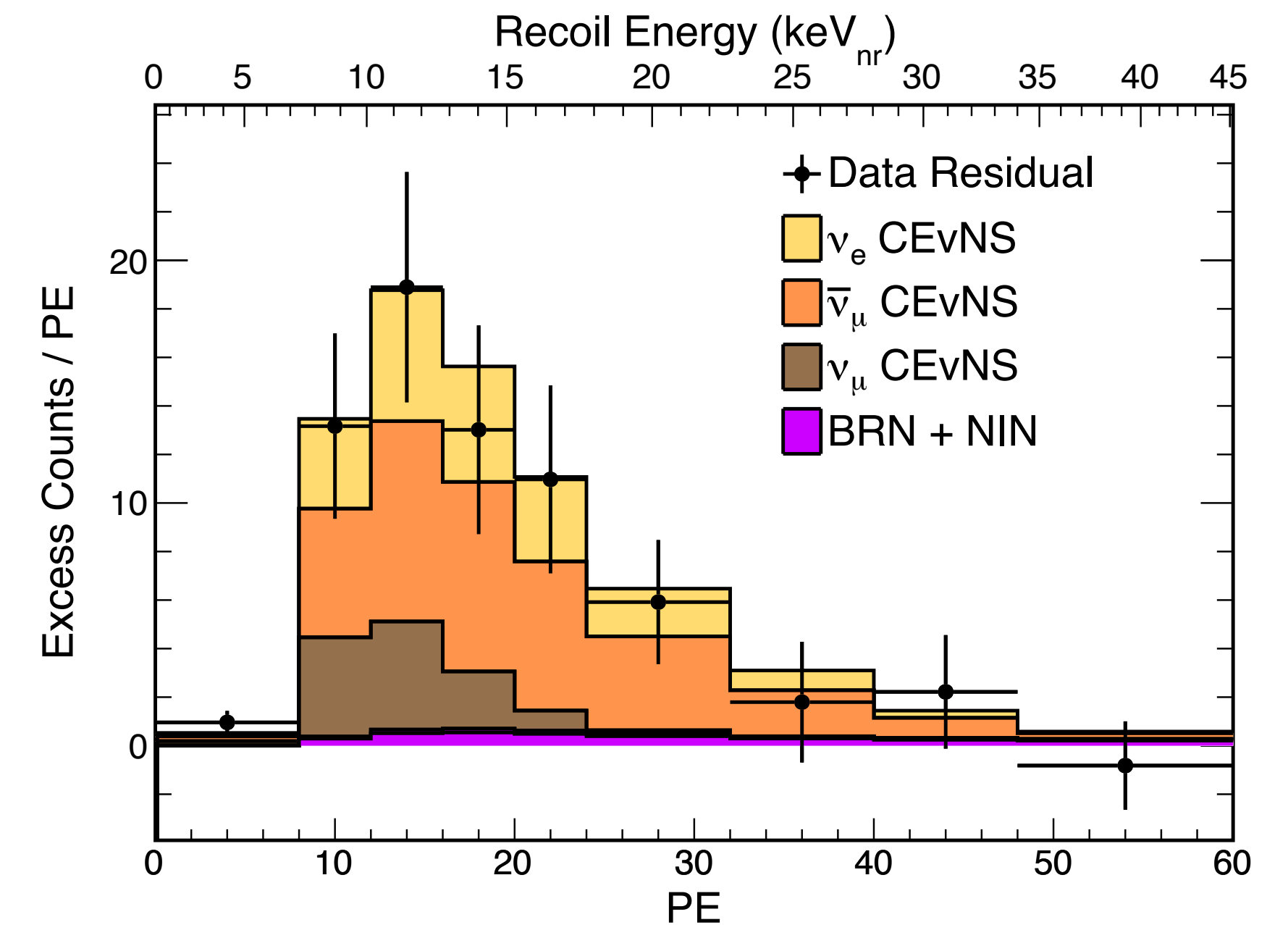
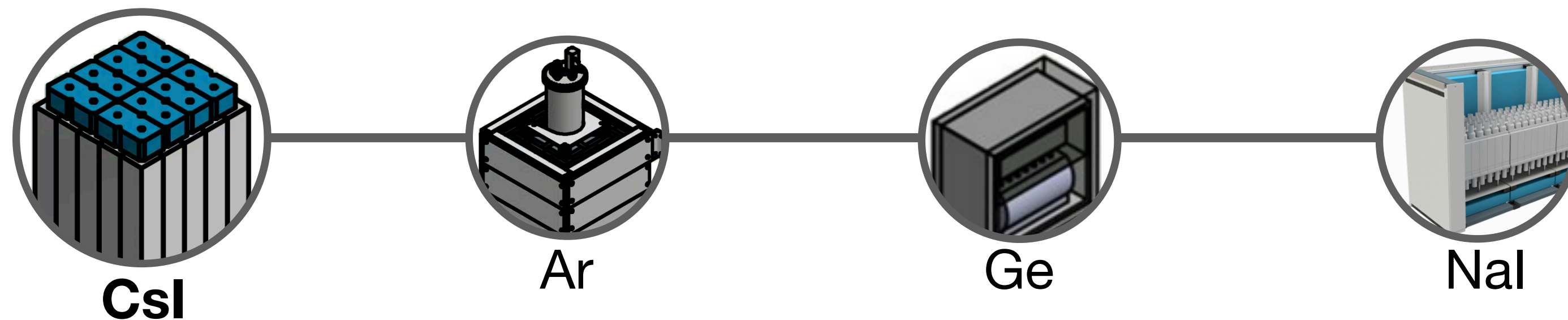

D. Akimov, et al., COHERENT, *Phys. Rev. Lett.* **129**, 081801 (2022)

CryoCsl

- 6.4 kg of undoped CsI operated at 77 K
 - LY: 13.35 PE/keV \rightarrow \sim 37 PE/keV
 - Threshold: 5 keV_{NR} \rightarrow 0.5 keV_{NR}
 - Signal: 165 counts/4 years \rightarrow \sim 340 counts/year
- CsI quenching factor measured at 77 K, PhD thesis of Charlie Prior and Yongjin Yang
- **Deployment in late 2026/2027**

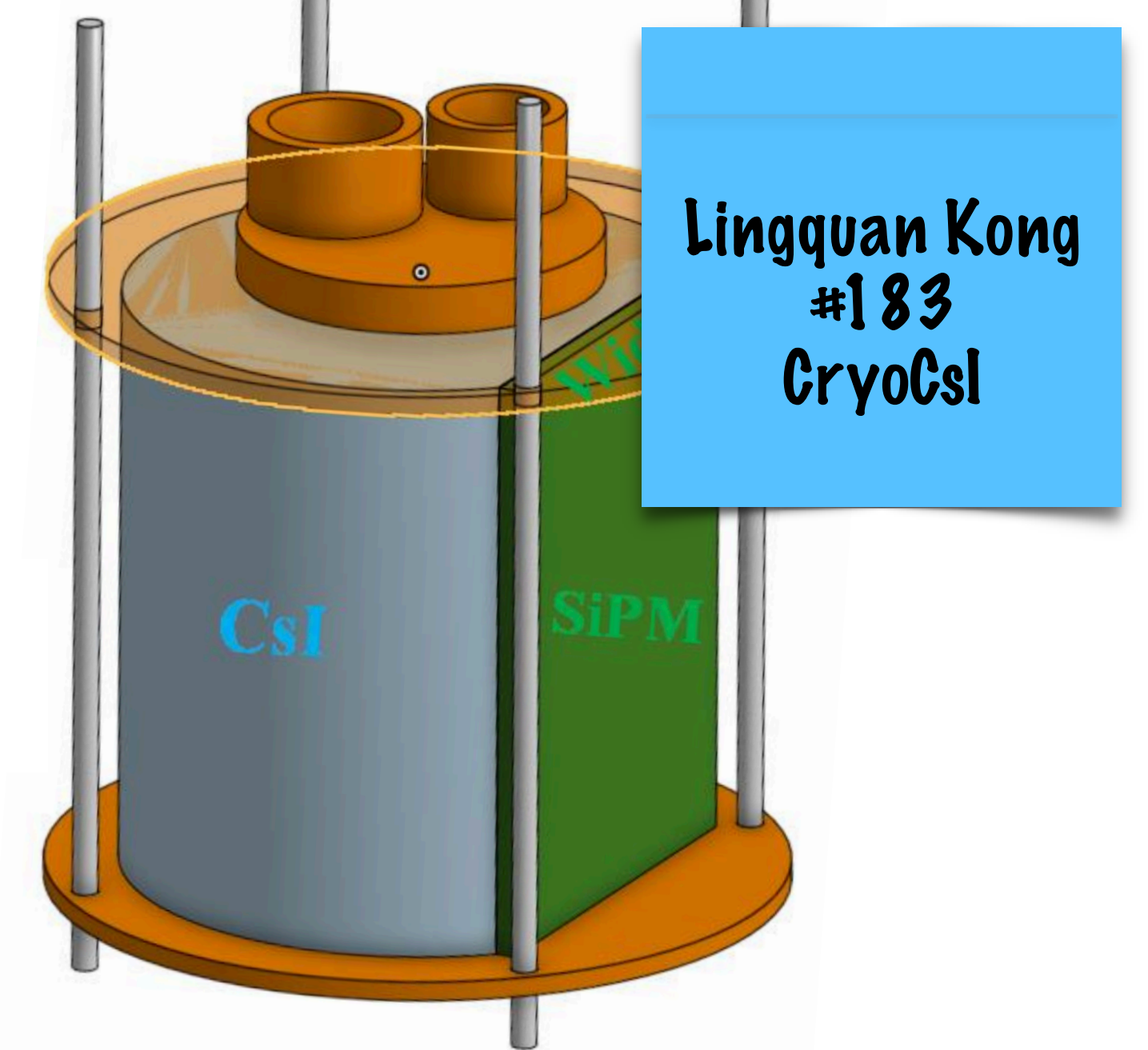
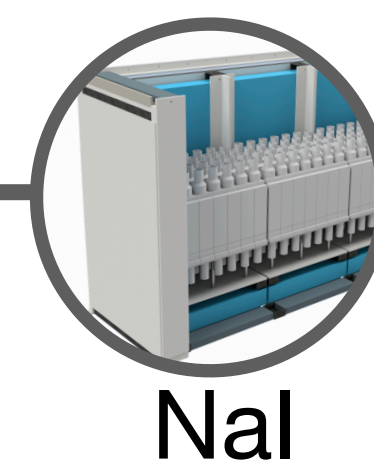
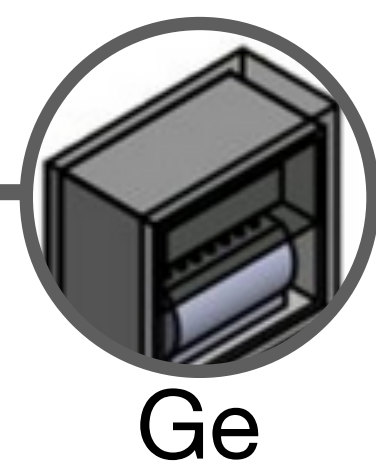
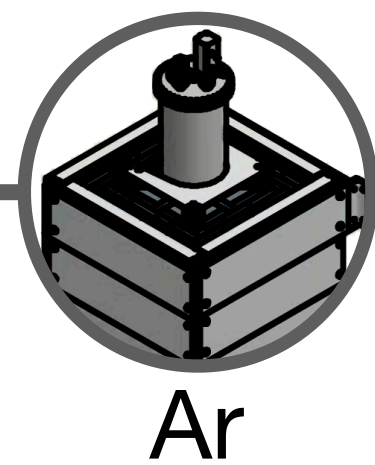
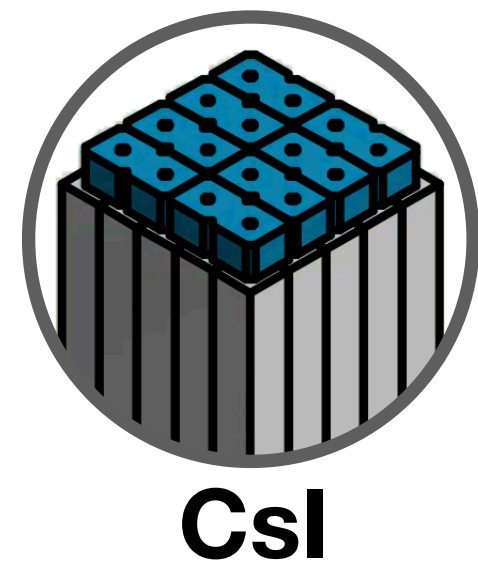

COH-Ar-10

CENNS-10

- Single-phase liquid argon detector
 - 24-kg fiducial volume, 2 PMTs
 - Time, energy, and PSD to identify nuclear recoils
 - Reported CEvNS at $\sim 3.5\sigma$ in 2021 w/6.12 GWHr
- **$\sim 3x$ the exposure** in full data set, under analysis!
- Improved control of neutron backgrounds
- Exploring re-deploying CENNS-10 w/neon

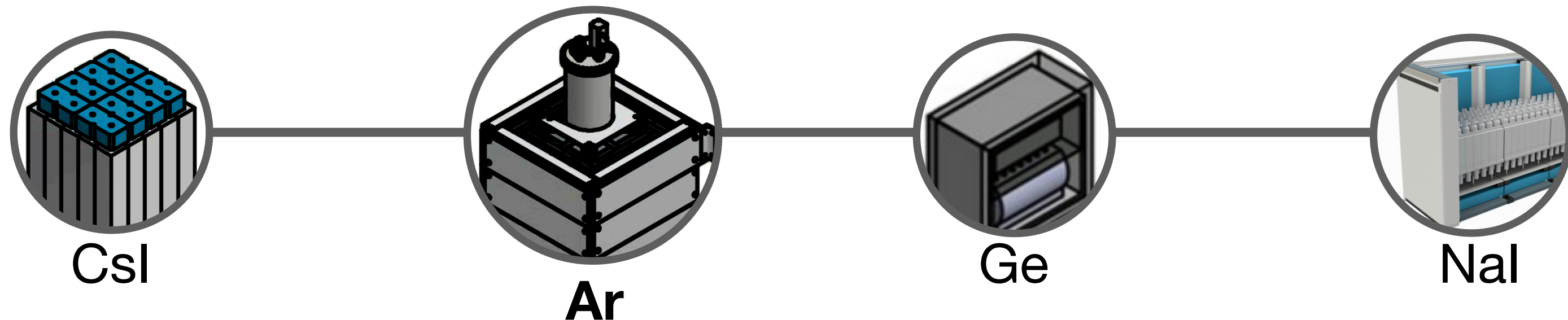

Isabel Colón
Rivera
#440
CEvNS on Neon

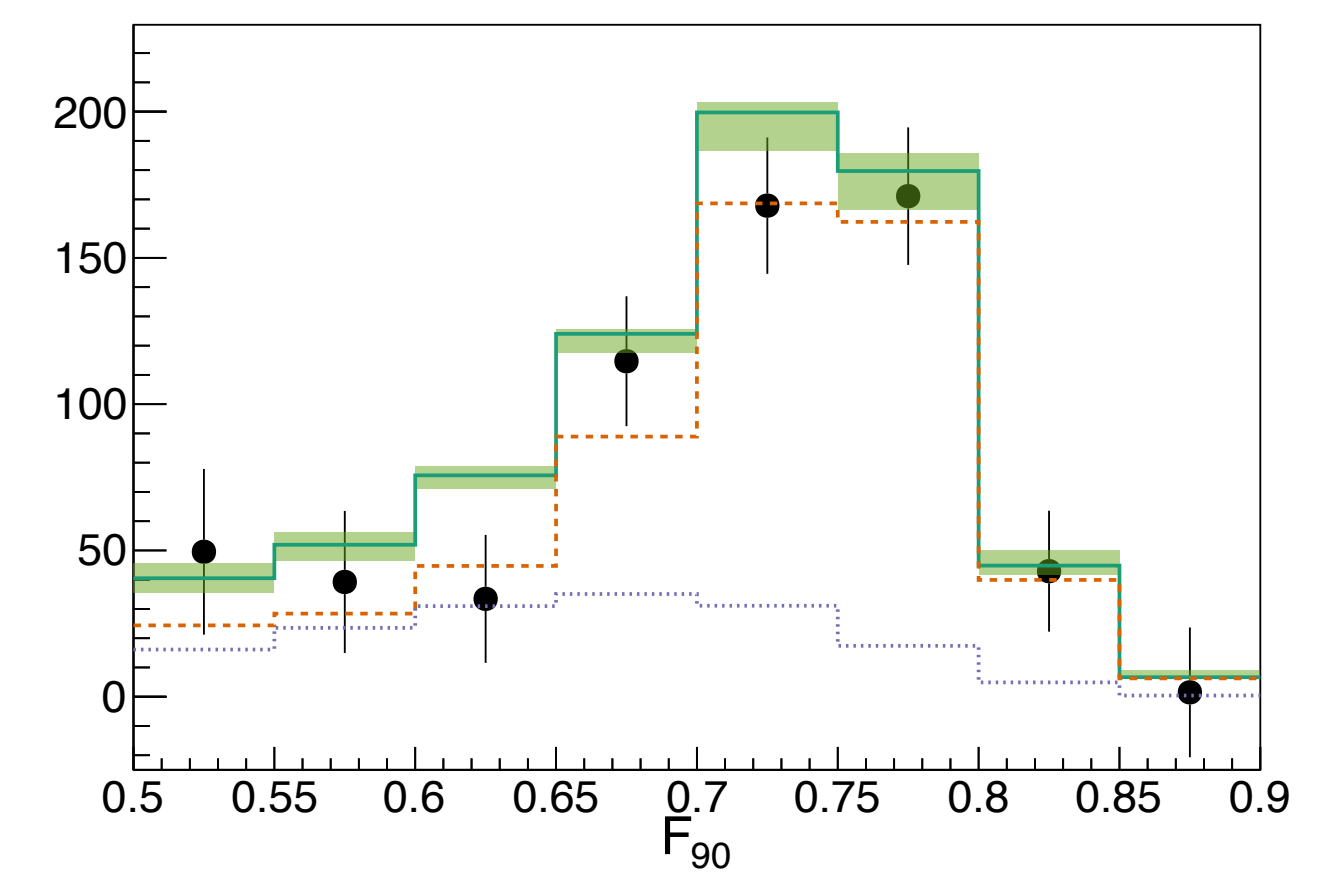
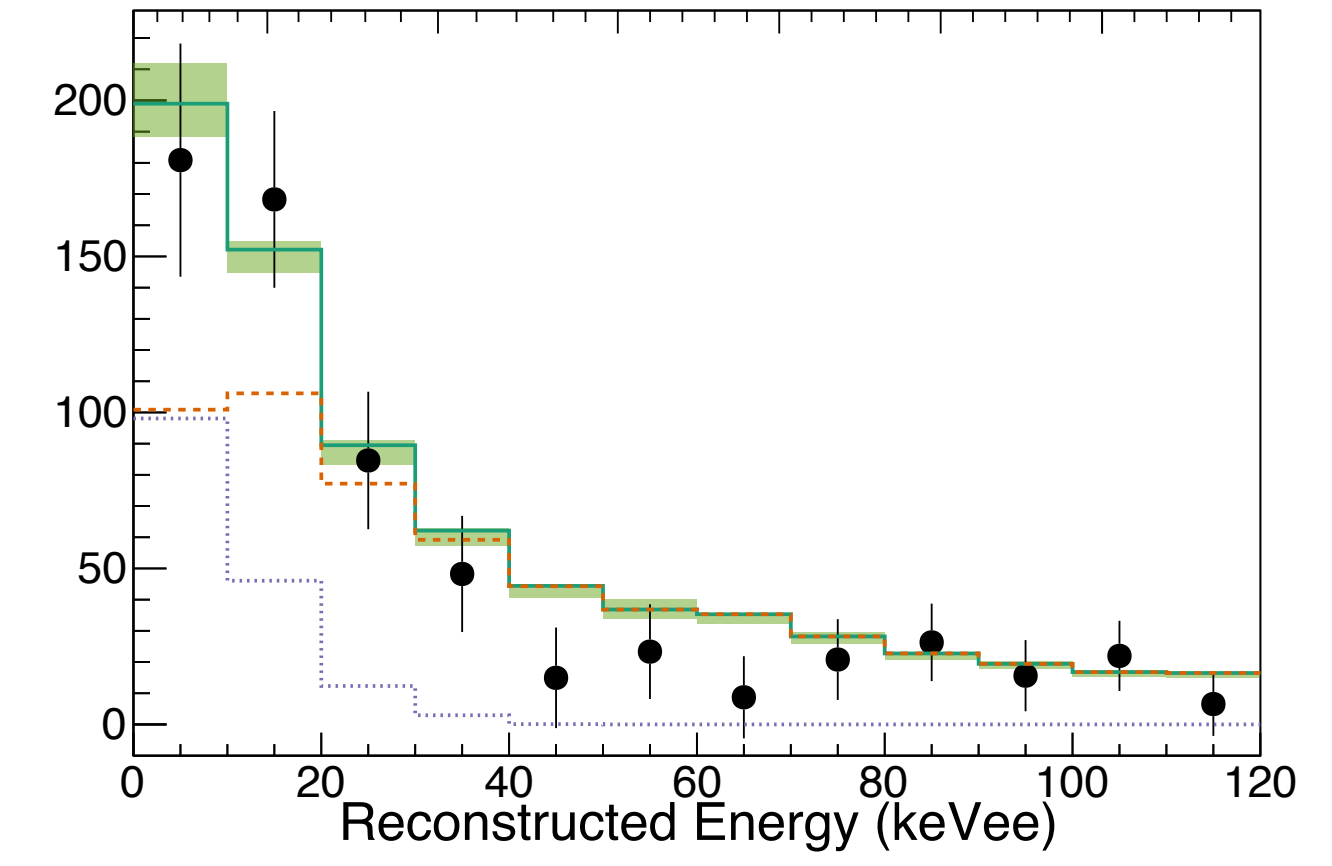
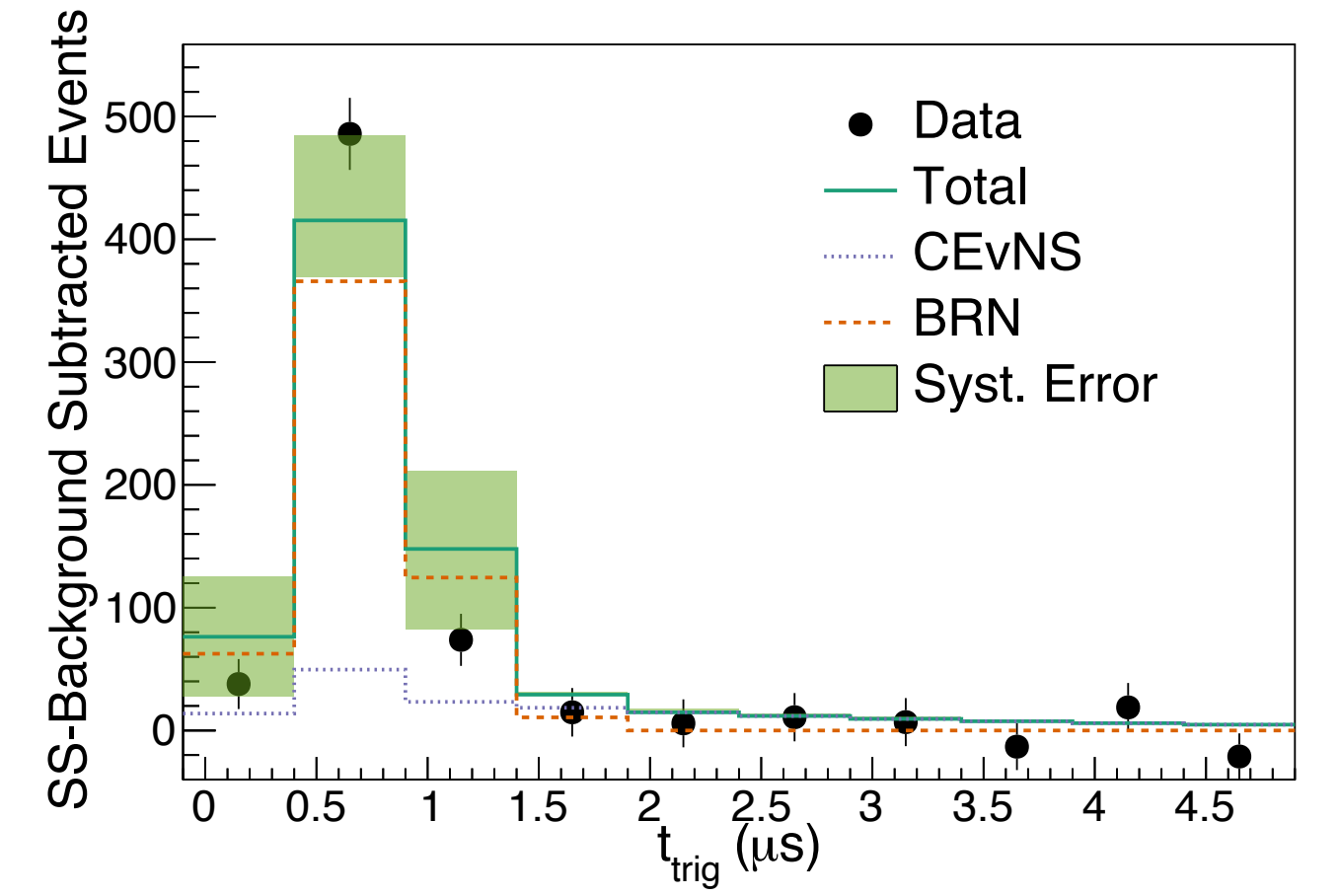

D. Akimov, et al., COHERENT, *Phys. Rev. Lett.* **126**, 012002 (2021)

COH-Ar-750

- Single phase 750-kg liquid argon detector
 - 476-kg fiducial volume
 - Occupies similar footprint as CENNS-10
 - Scintillation read out w/122 PMTs
- Expect ~5,000 CEvNS counts/year
- Being commissioned at ORNL, **planned deployment in 2026!**

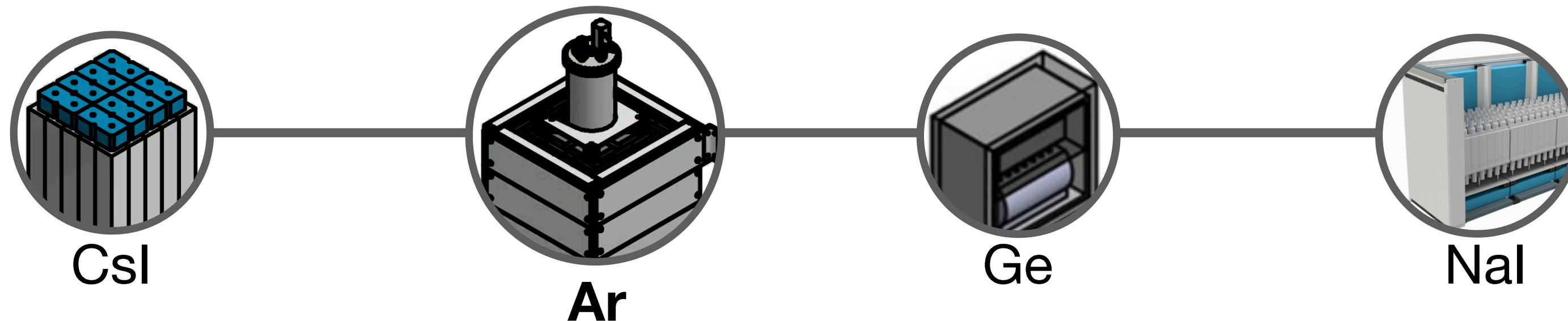
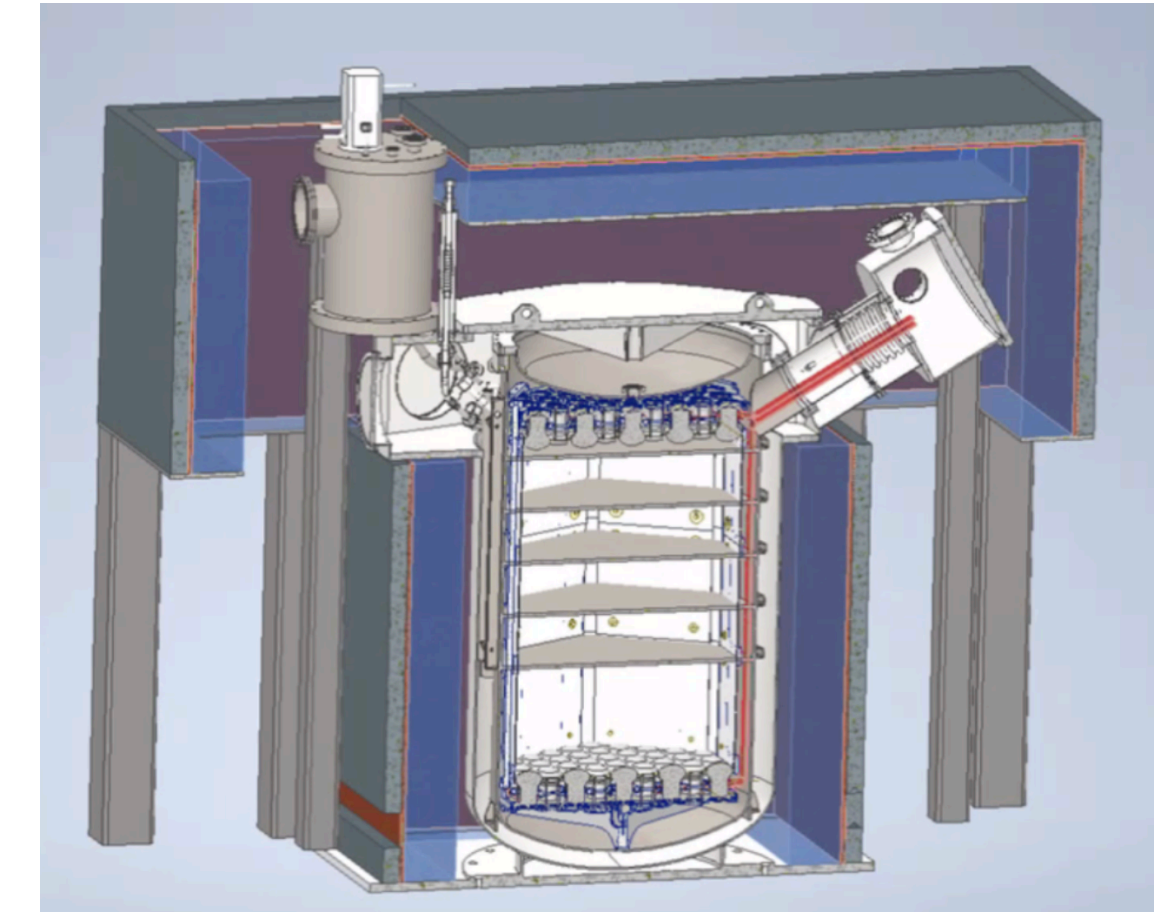

Ge-Mini

- 18-kg inverted coaxial p-type point contact germanium detectors
- Excellent energy resolution, low backgrounds, and low thresholds
- Reported first measurement in 2024
 - ~3 month exposure
 - 1.5 keV_{ee} threshold
 - 3.9 σ significance

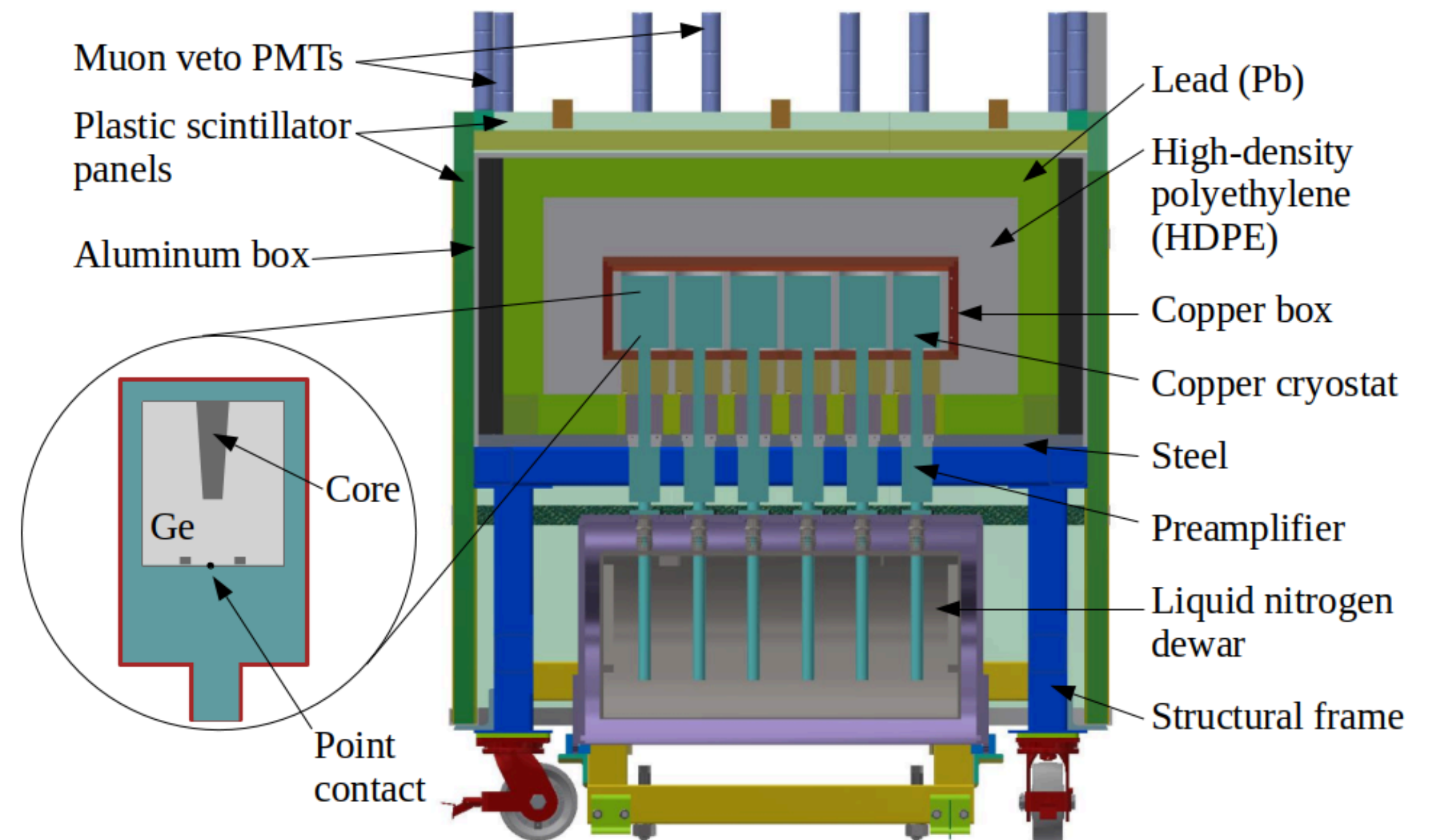
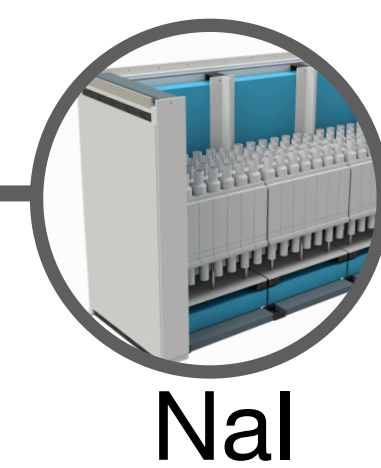
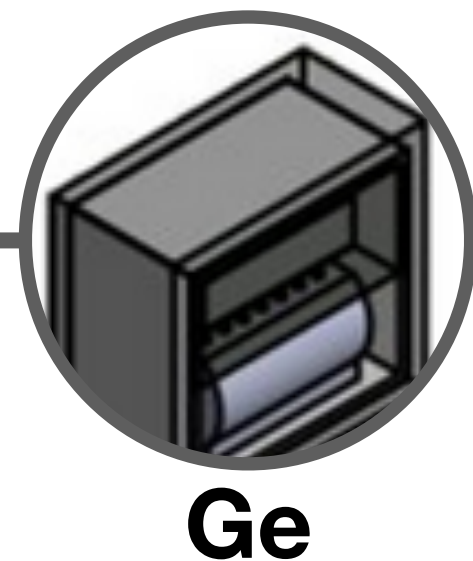
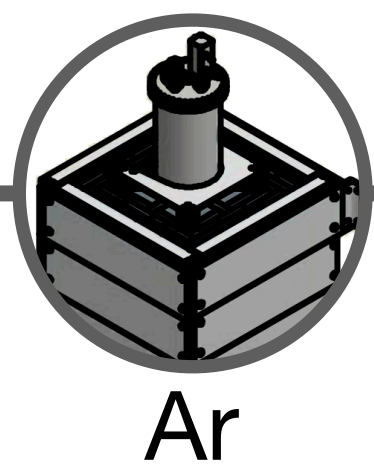
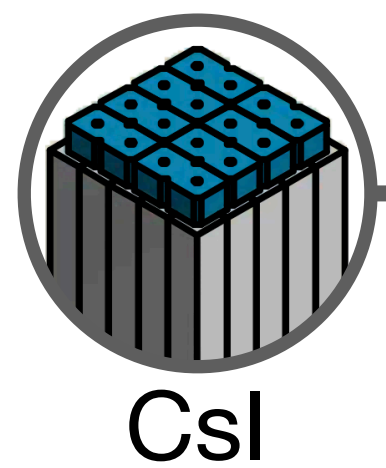

S. Adamski, et al., COHERENT, *Phys. Rev. Lett.* **134**, 231801 (2025)

Ge-Mini: new dataset!

Ryan Bouabid
#367
GeMini analysis
campaign 3

Nick Meredith
#455
GeMini analysis
campaign 2

Emma van
Nieuwenhuizen
#416
Form factors w/
Ge data

- New result on arXiv (2603.17951)
 - 4 month exposure
 - **ML to identify cross talk**
 - Threshold: $1.5 \text{ keV}_{ee} \rightarrow 0.5 \text{ keV}_{ee}$
 - Evidence of CEvNS with $4.8\text{-}5.7\sigma$ per detector!
- First systematics-limited data set

Beam-off

Beam-on

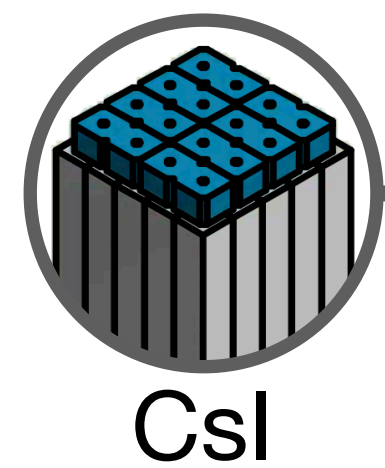
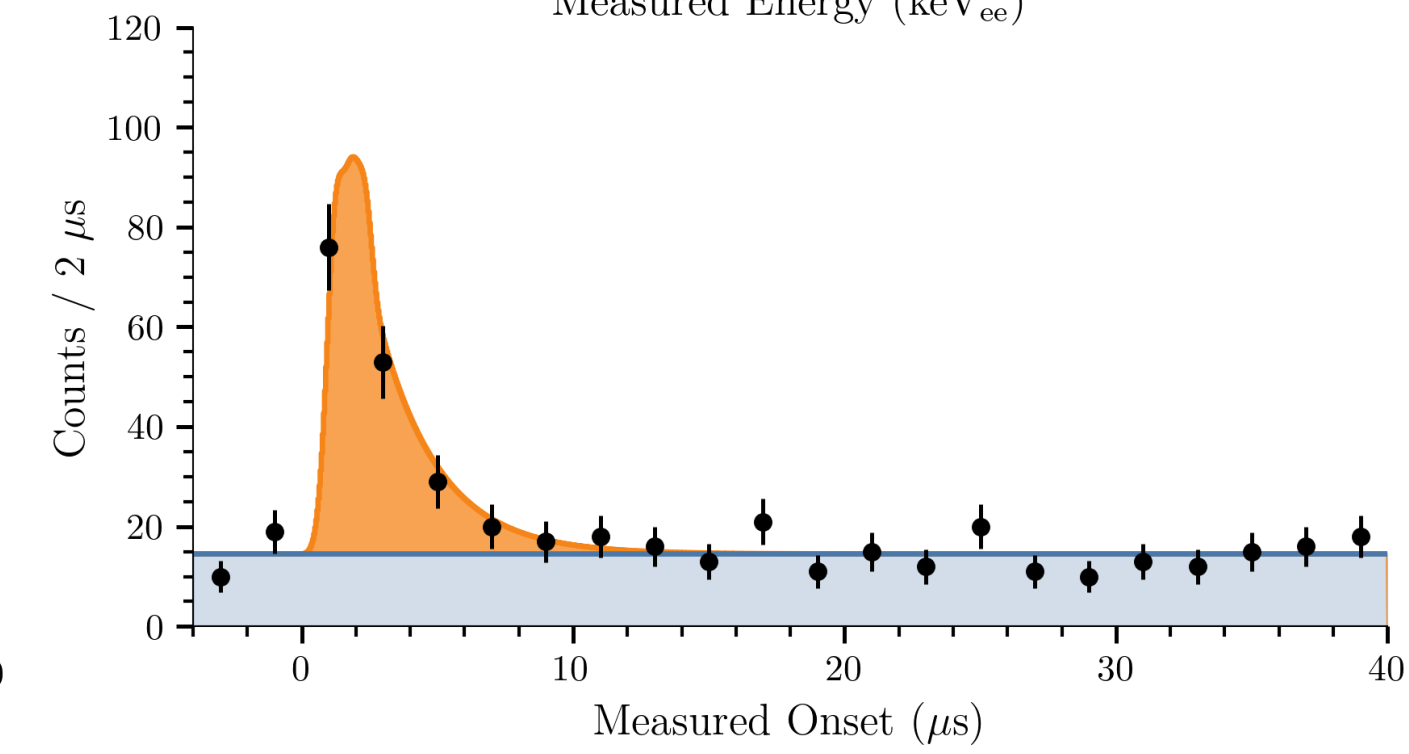
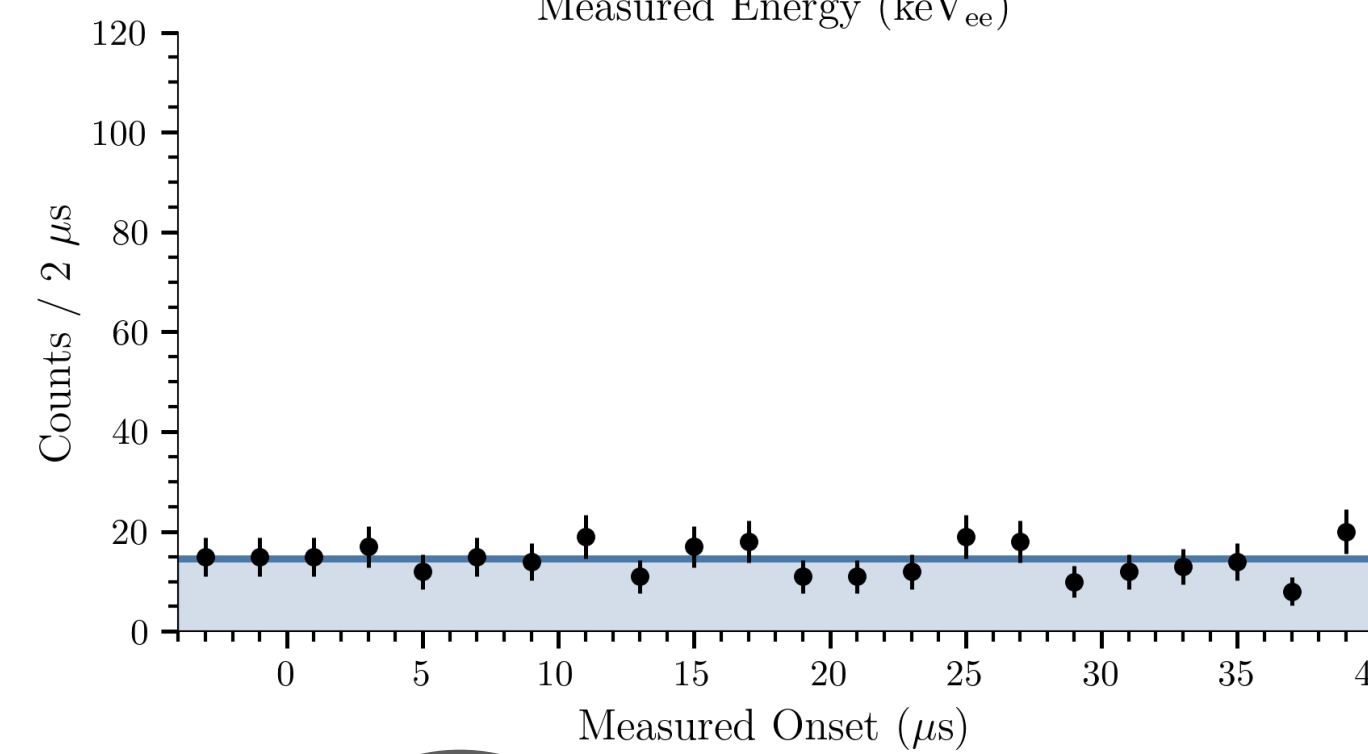
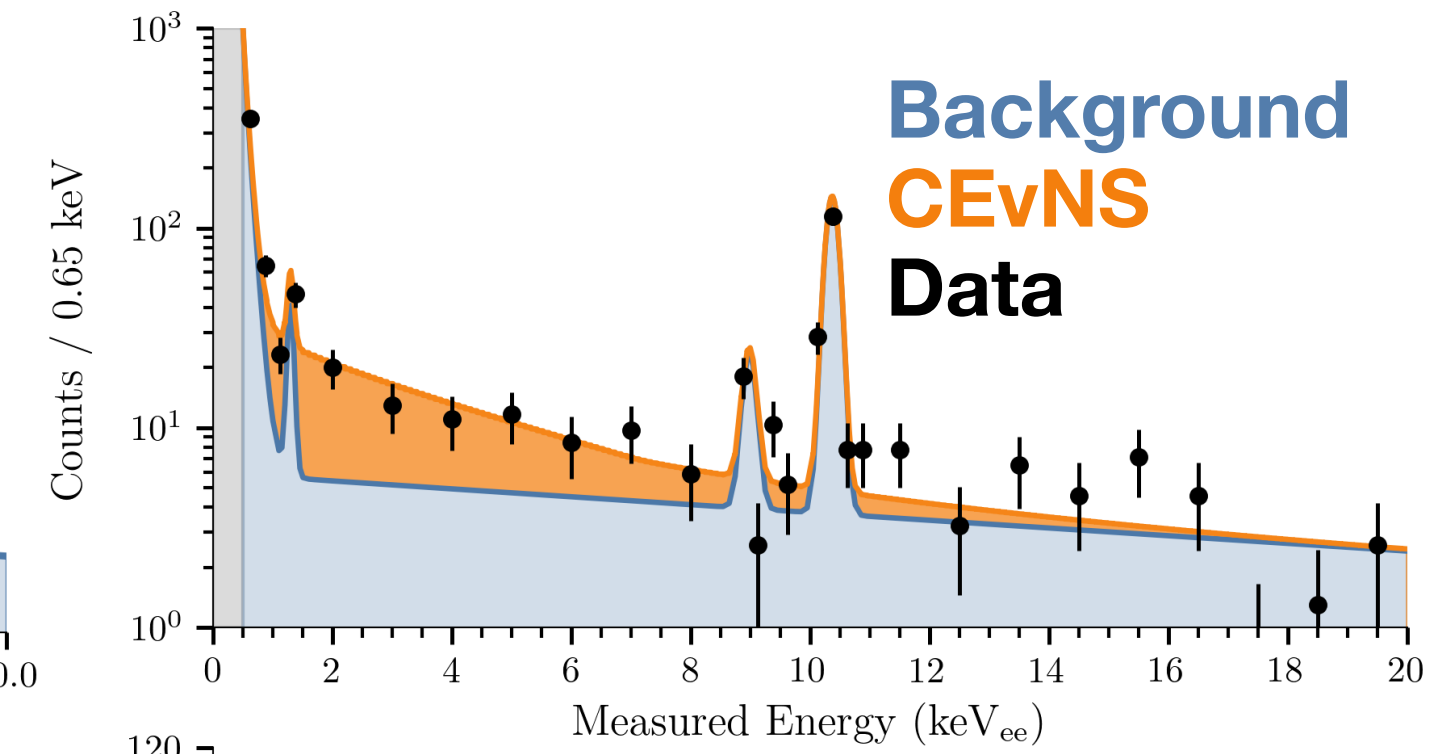
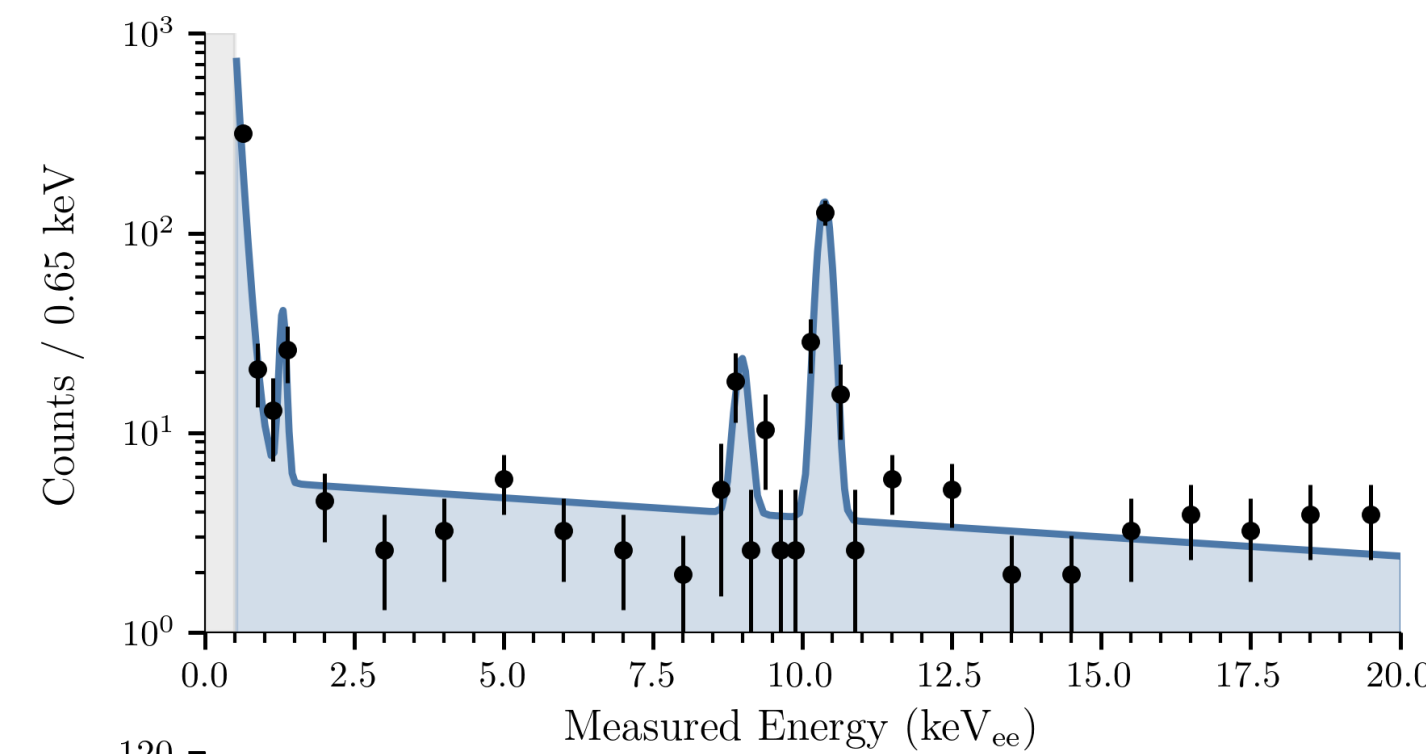

CsI

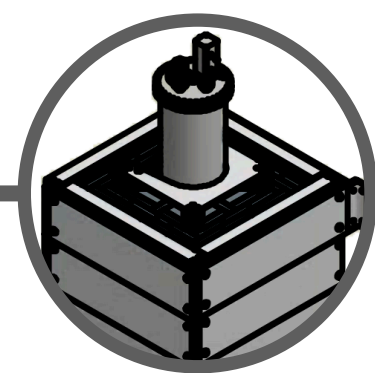

Ar

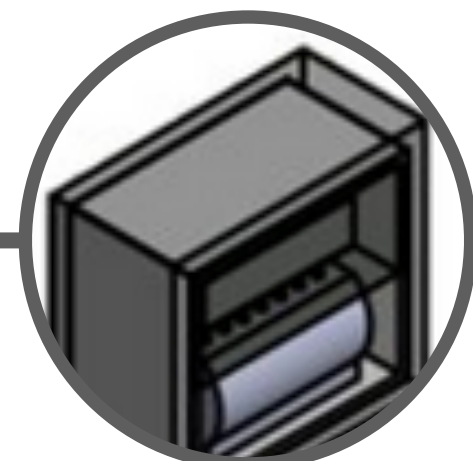

Ge

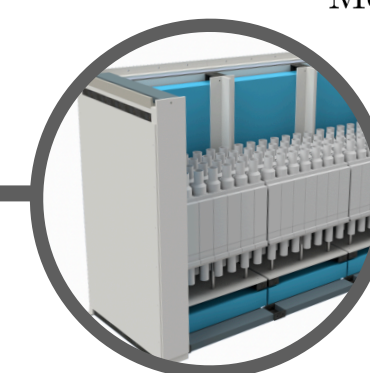

NaI

NalvETE

Nal ν -Experiment TonnE-scale

- Largest detector (1.4/2.4 tons NaI deployed)
- Lightest target: ^{23}Na recoils w/3 keV_{ee} threshold
- Detector of opportunity—repurposed crystals from Advanced Spectroscopic Portal program
- Upgrading subset with low-noise high-gain PMTs to observe ^{127}I recoils (0.5 keV_{ee} threshold)

Jane O'Reilly
#292
NalvETE: CEvNS
on NaI

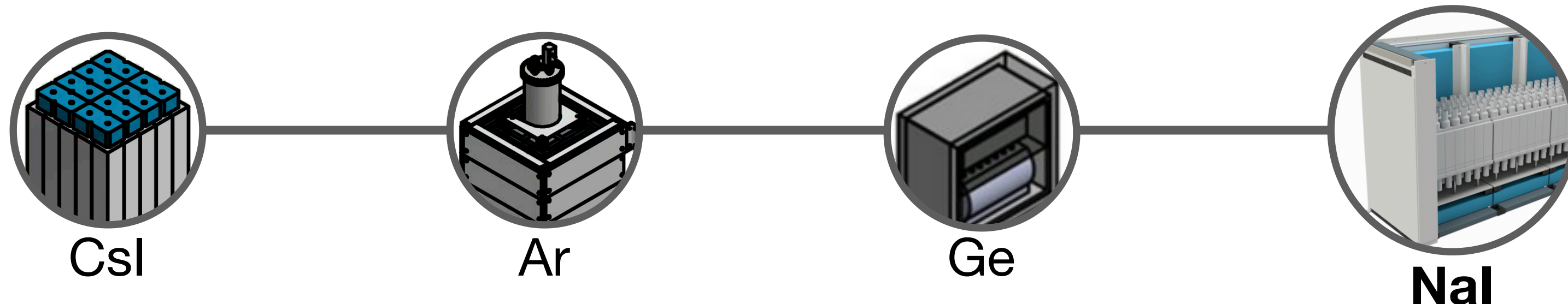
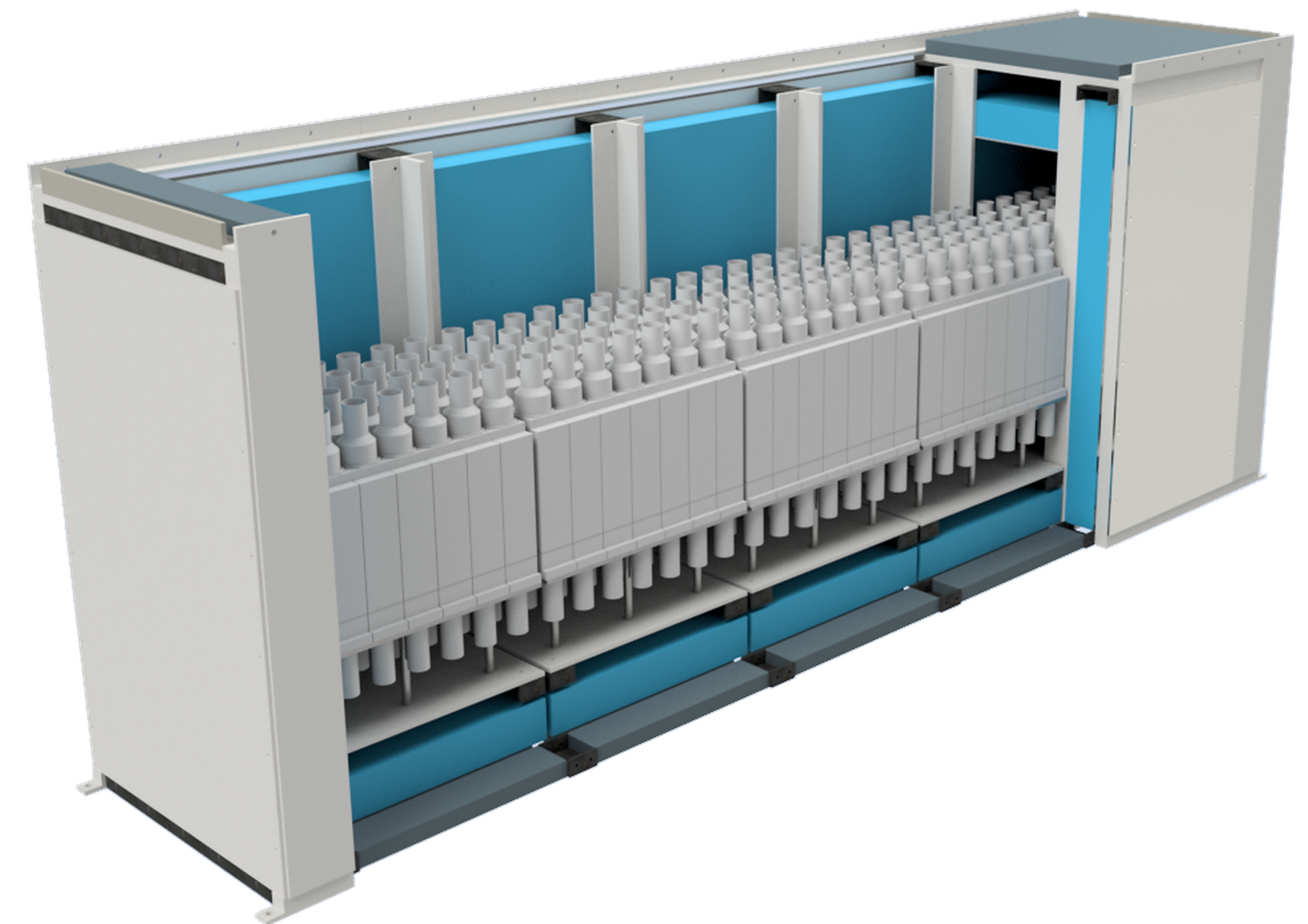
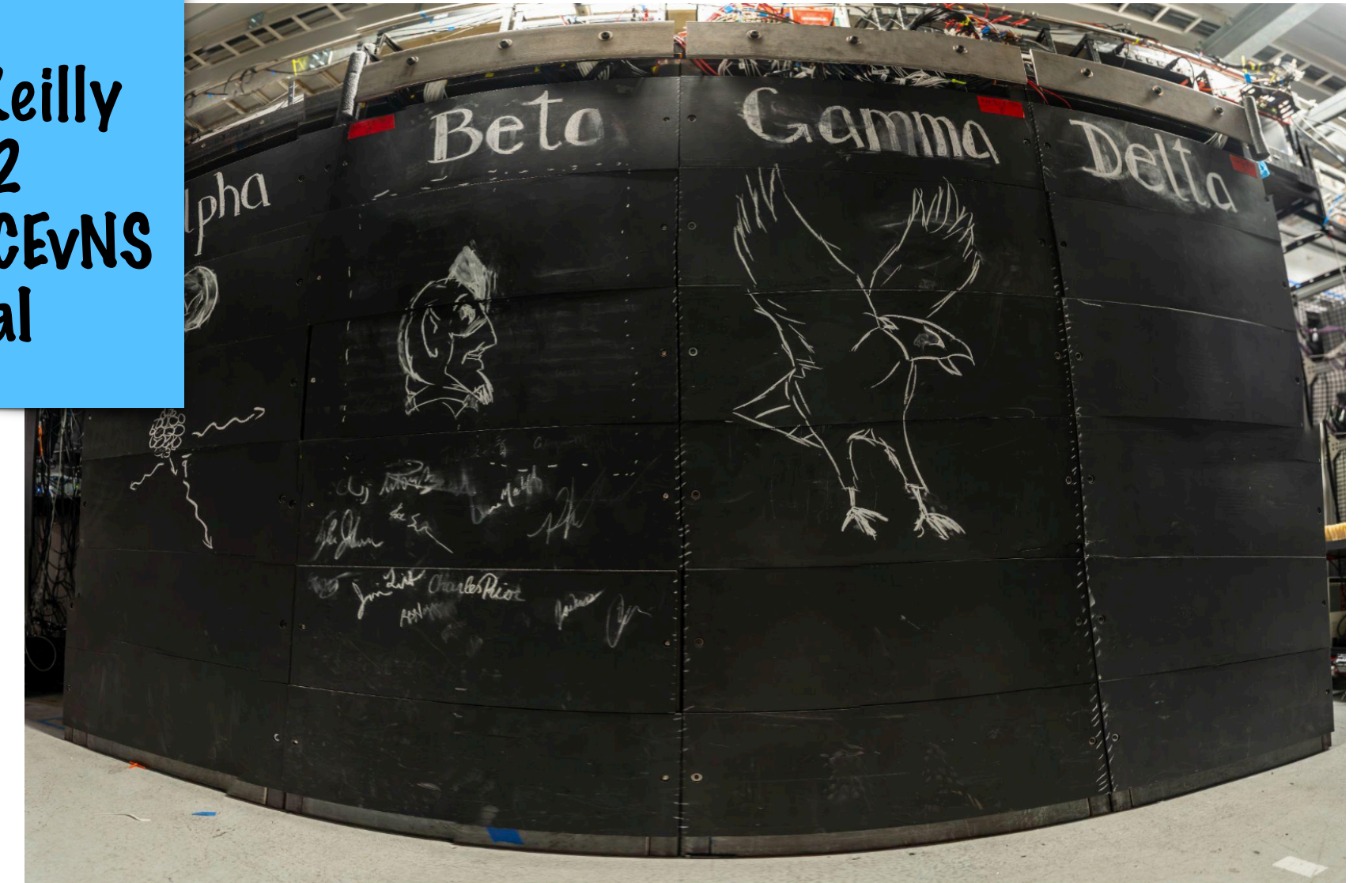

Case study: Weak mixing angle

2017 Csl:

- $0.117 < \sin^2\theta_W < 0.315$ ^[1]

2017 Csl + 2020 Ar:

- $\sin^2\theta_W = 0.26^{+0.04}_{-0.03}$ ^[2]

2026 Ge:

- $\sin^2\theta_W = 0.235^{+0.021}_{-0.020}$ ^[3]

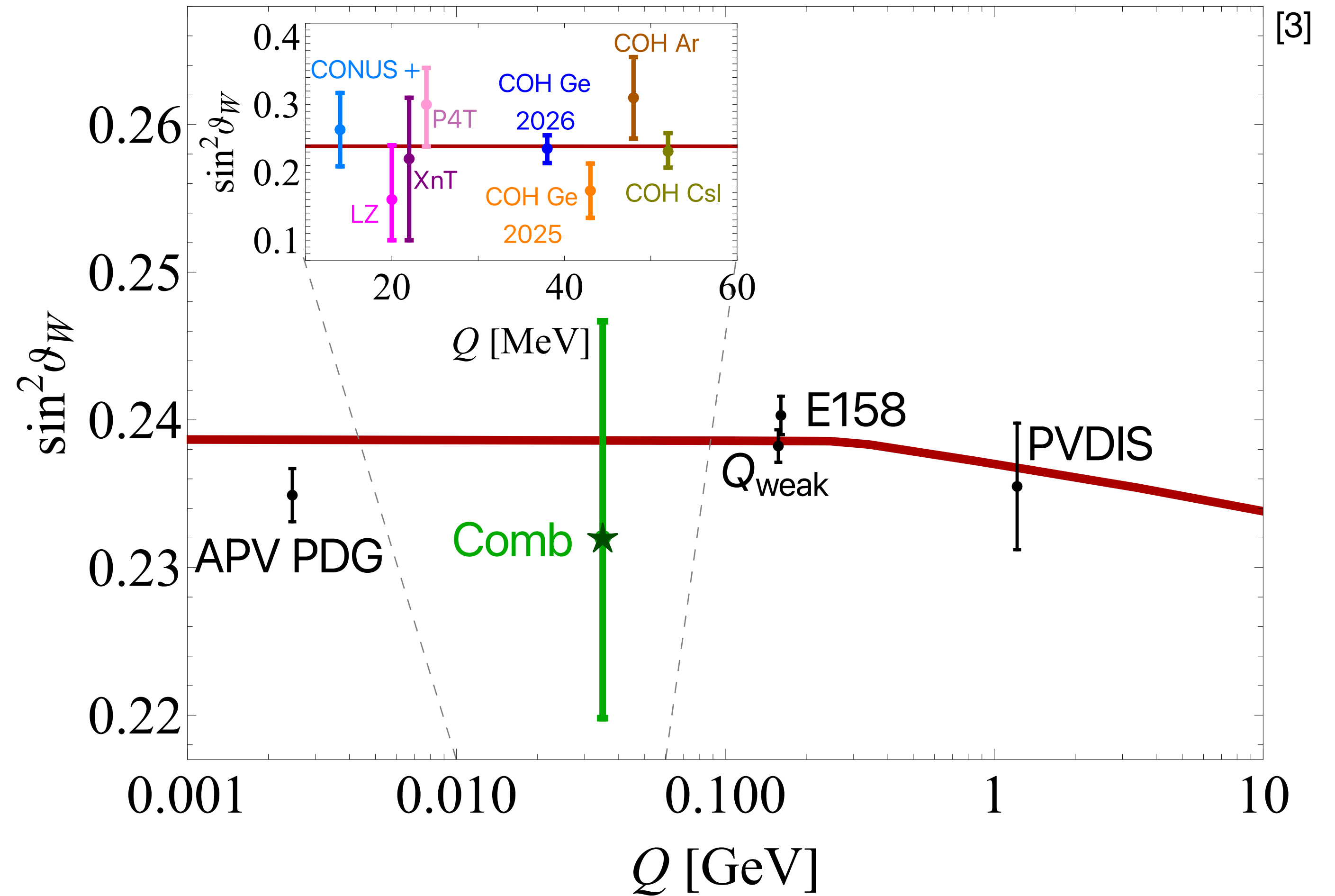

[1] D. K. Papoulias and T. S. Kosmas, *Phys. Rev. D* **97**, 033003 (2018)

[2] M. Caddeu, et al., *Phys. Rev. D* **102**, 015030 (2020)

[3] M. Atzori Corona, et al., *arXiv:2605.07975* (2026)

N^2 -dependence

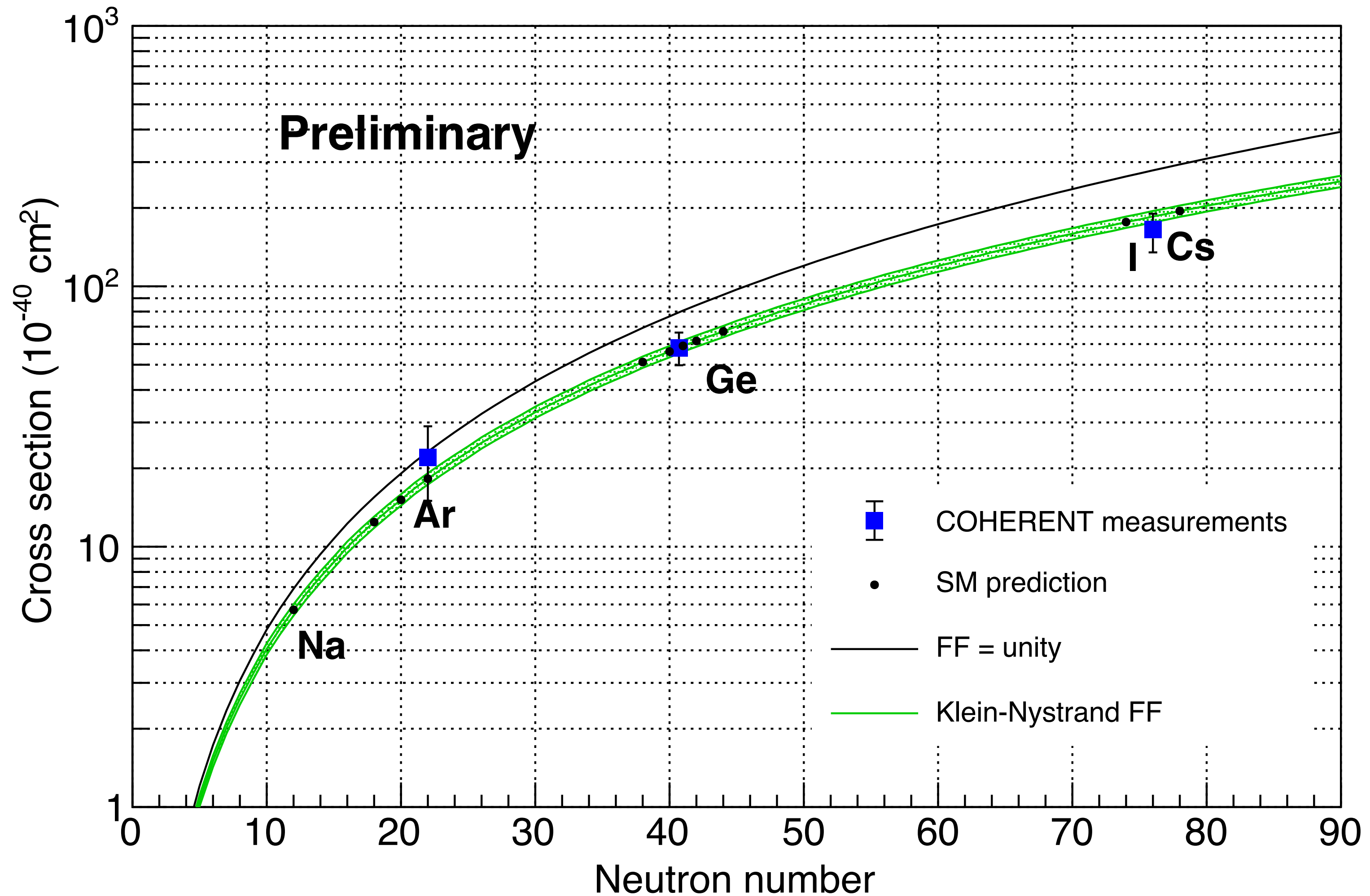

All measurements share 10% systematic unc. from neutrino flux normalization

D₂O: Reducing flux uncertainty

- Deuterium ν_e charged-current cross section calculated with few percent theoretical uncertainties
- 549 kg of heavy water deployed to the SNS in 2023
- Goal: reduce flux normalization uncertainty to 3-5% level within 5 years — **analysis underway!**
- Second module w/H₂O to study non-deuterium neutrino scattering



Eli Ward
#179
D₂O analysis

Seung Mok Lee
#82
D₂O/H₂O
deployment



D. Akimov, et al, COHERENT, *JINST* 16 P09048 (2021)

Beyond CEvNS

Charged-current neutrino-nucleus scattering

- Neutrino flux normalization
- Neutrino-induced backgrounds
- Calibrating SN neutrino detectors
- Make novel measurements of neutrino-nucleus cross sections
- ...and more!

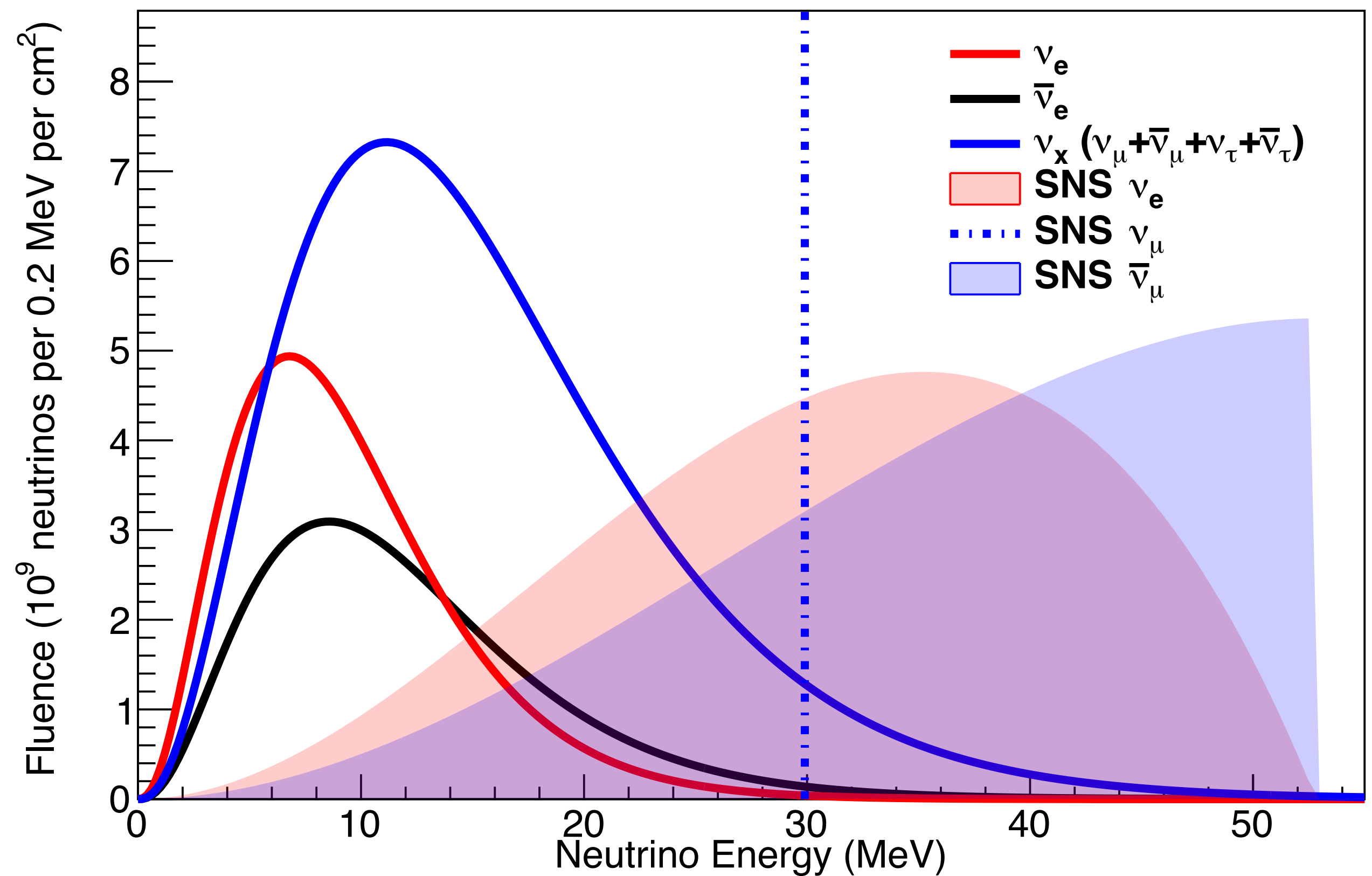

Neutrino-induced backgrounds

Natalie Jones
#175
Metal sandwich
(CC)

Ana Zaalishvili
#207
NEP-ton: Pb CC

- CEvNS detectors surrounded by tons of lead
- Charged-current scattering can generate neutrino-induced neutrons (NINs)

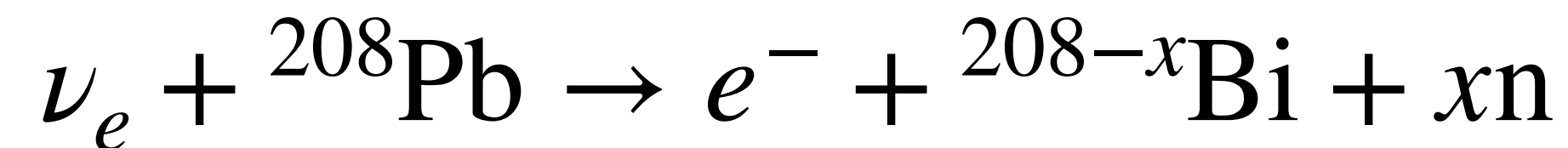

- Expected to be smaller than CEvNS, but unmeasured, large theoretical uncertainties
- Collaboration deployed two detectors to study this process
- Initial results see suppression in NIN production - **not a major background for CEvNS detectors**

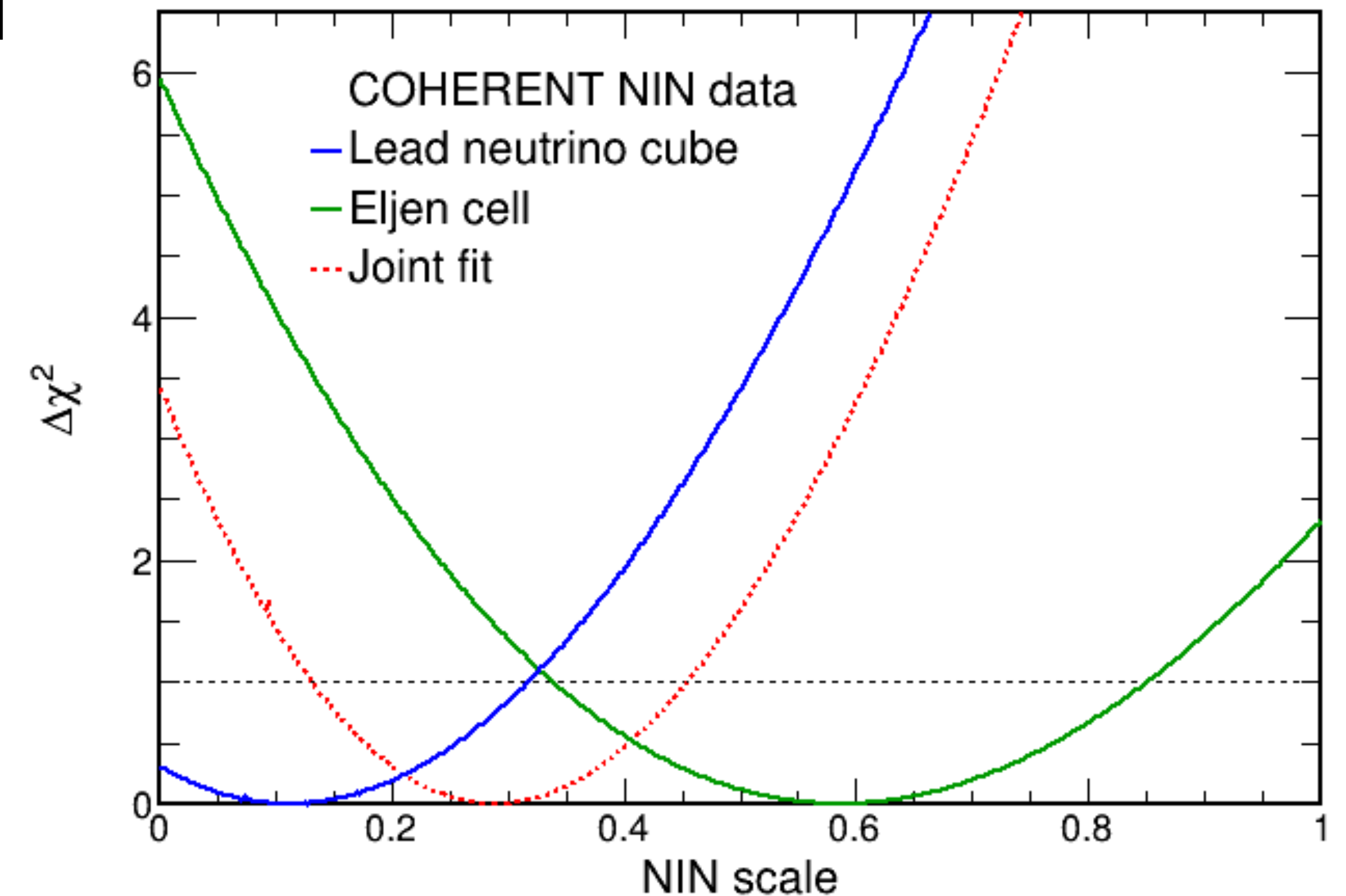

Calibrating supernova neutrino detectors: Lead, Argon, and Oxygen

HALO



Ana Zaalishvili
#207
NEP-ton: Pb CC

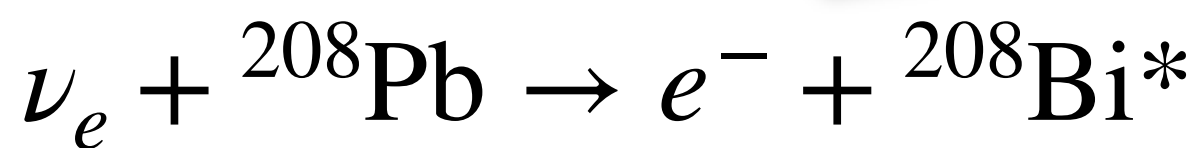

DUNE

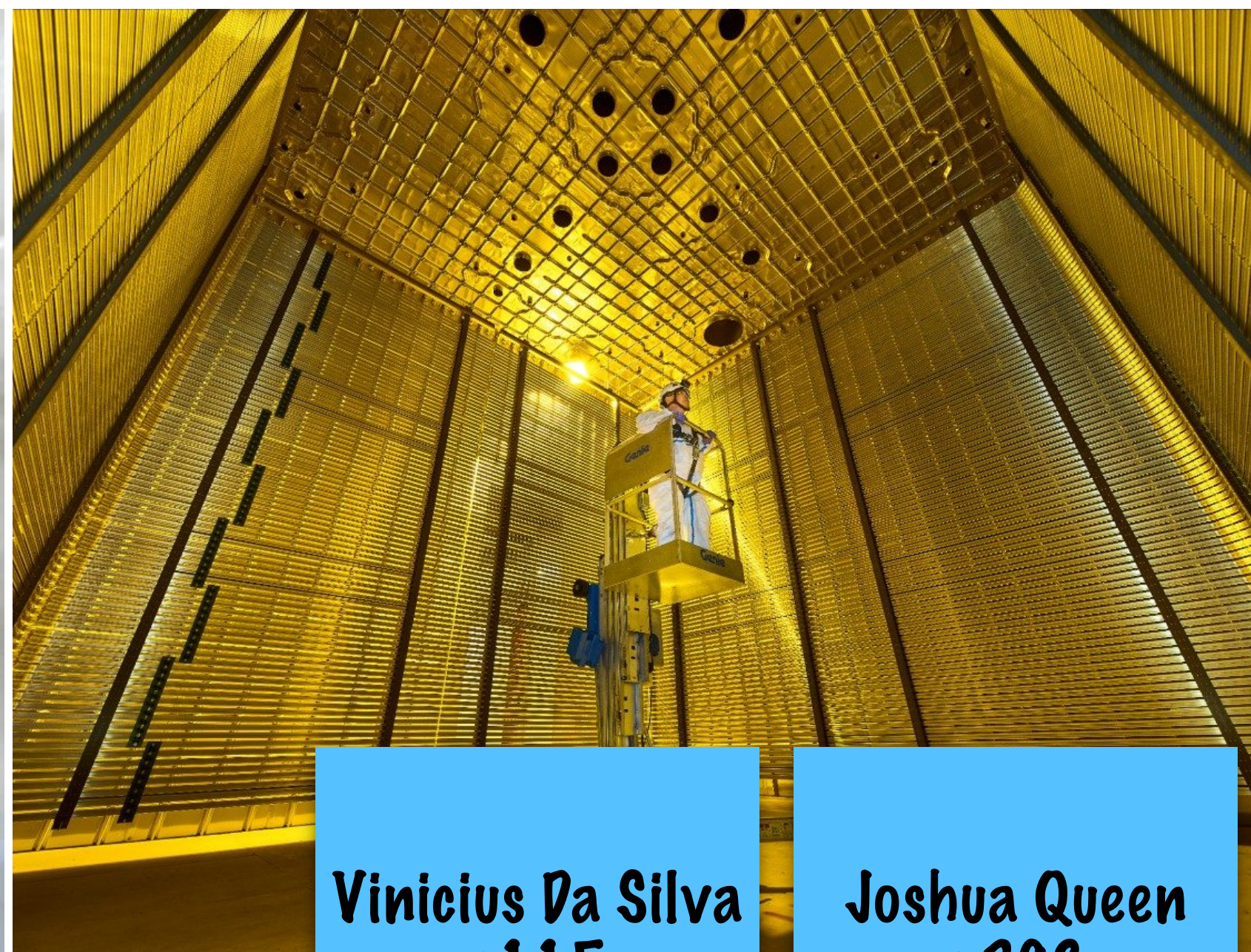

Vinicius Da Silva
#115
Argon CC in
CENNS-750

Joshua Queen
#268
Argon CC in
CENNS-10

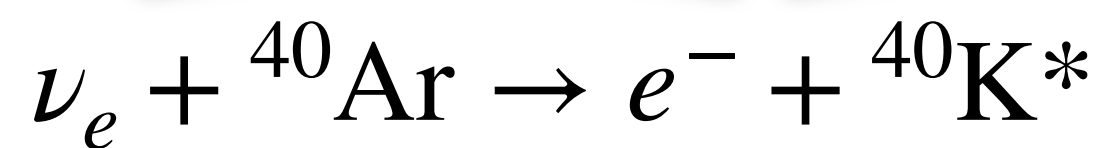

Super-K/Hyper-K

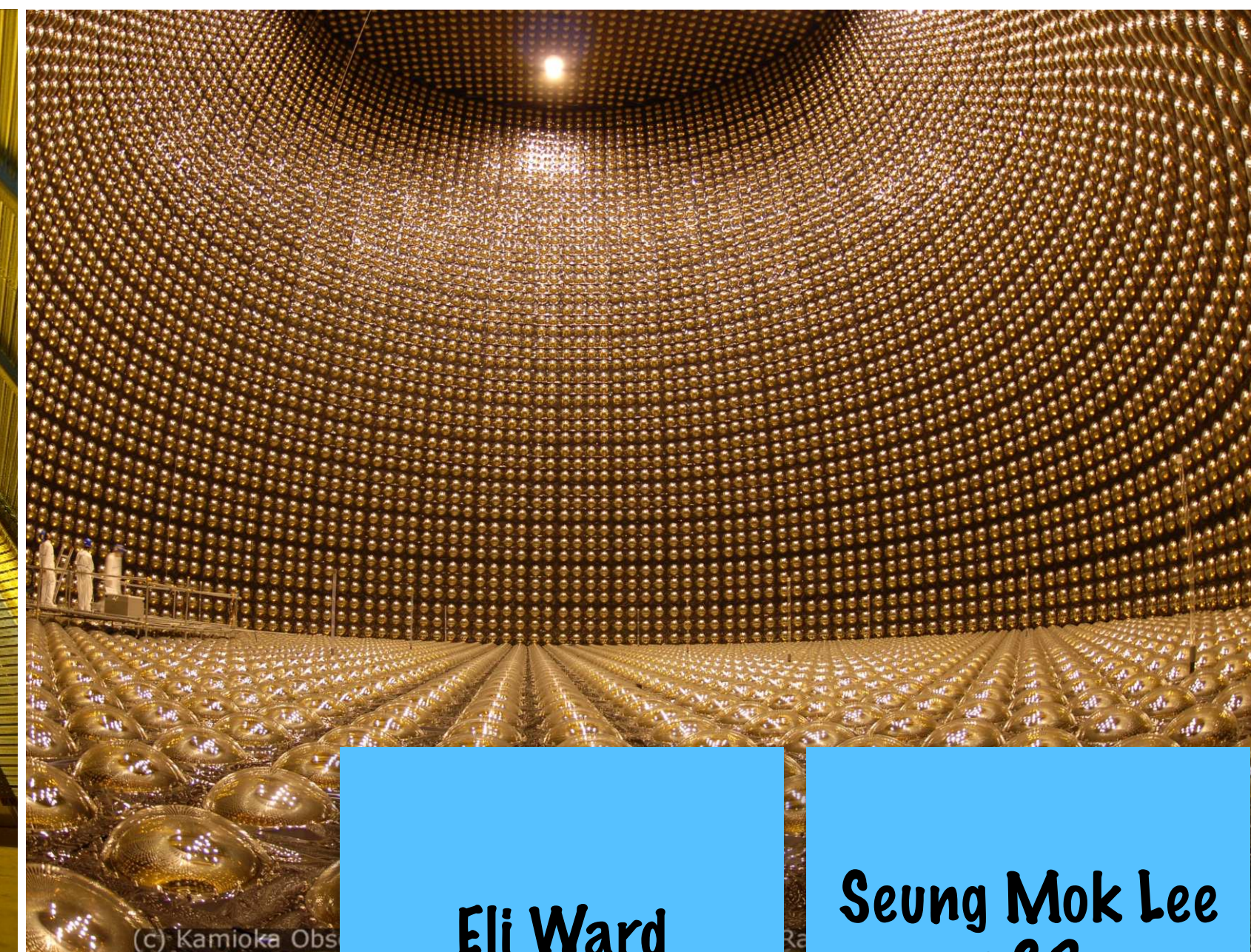

Eli Ward
#179
D₂O analysis

Seung Mok Lee
#82
D₂O/H₂O
deployment

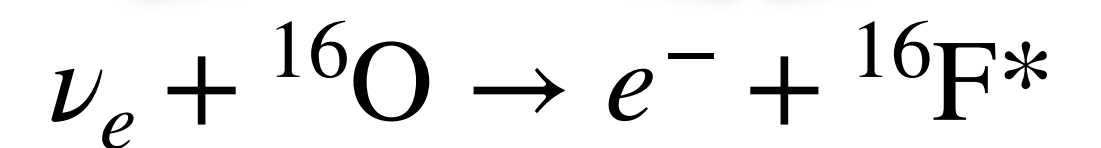

NU THOR:

A first measurement of neutrino-induced fission

- Unique opportunity at ORNL—intense ν_e source + 52 kg of ^{232}Th
- Neutrino-induced fission first predicted in 1971^[1]
 - Charged-current interaction induces a ^{232}Th fission
- Signature is large number of fission neutrons following neutrino pulse
- 2.4σ result in Tyler Johnson's PhD thesis, **~3.5x exposure!**



Tyler Johnson
#275
NuThor:
neutrino-
induced fission

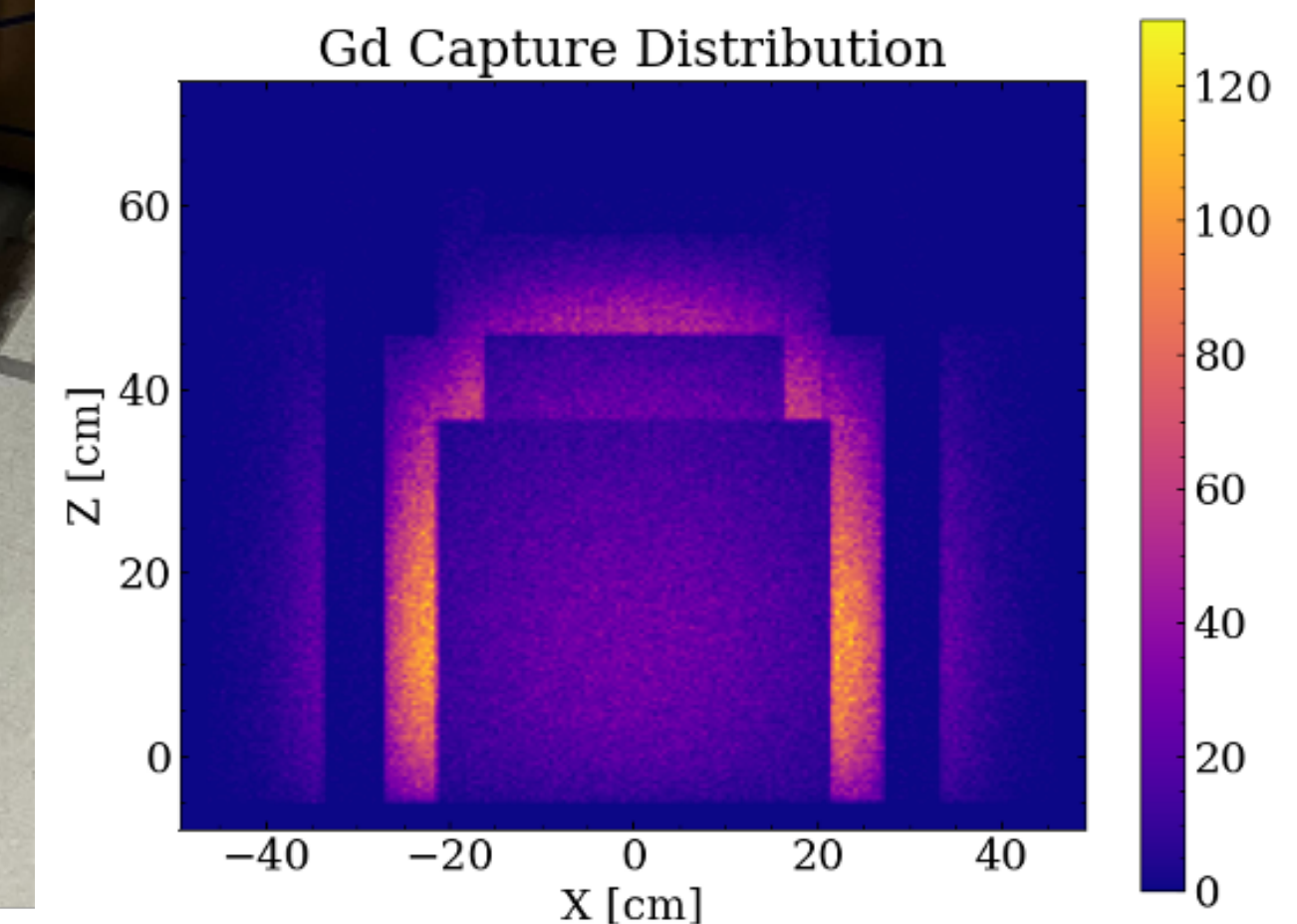
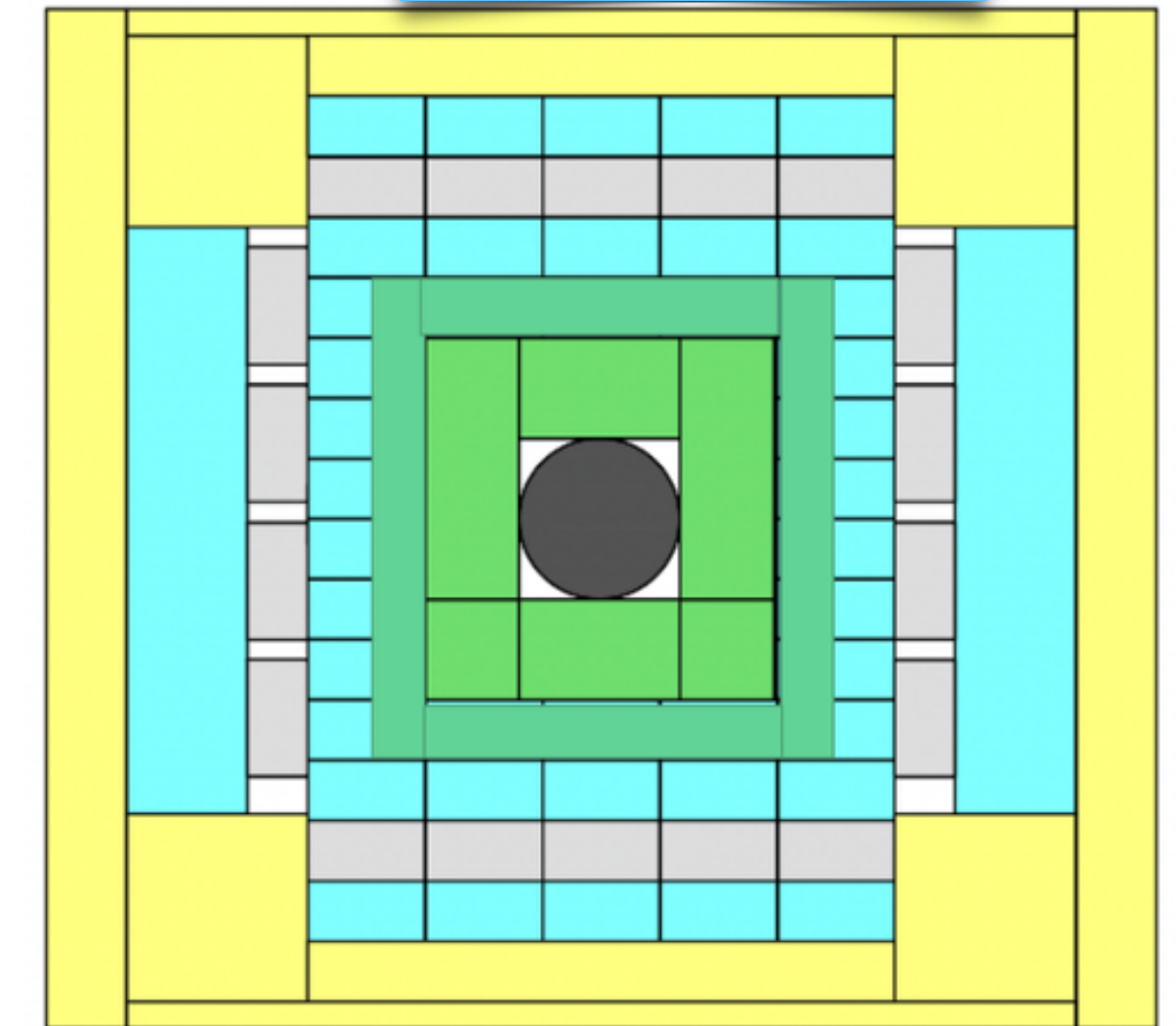

[1] V. I. Andryushin, S. M. Bilen'kii, and S. S. Gershtein, *JETP Lett.* **13**, 409 (1971)

T. Johnson, *The First Indication of Neutrino-Induced Nuclear Fission*, Ph.D. thesis, Duke University (2024)

Future Outlook

COHERENT: Then and now

Circa 2017

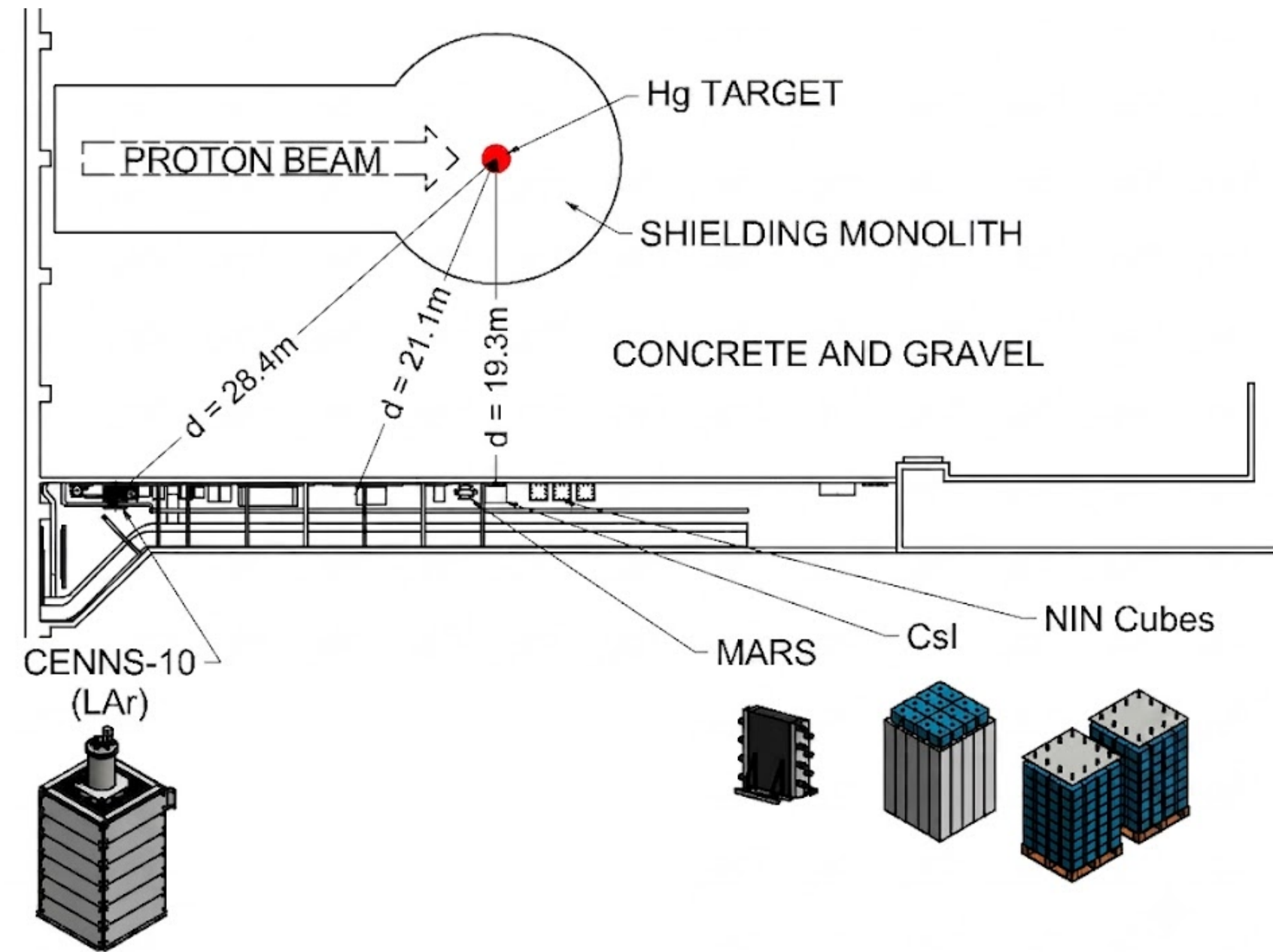

- ~80 members, 19 institutions
- Deployed 4 neutrino detectors
- 2 PhD theses
- ~134 neutrinos detected

Circa 2026

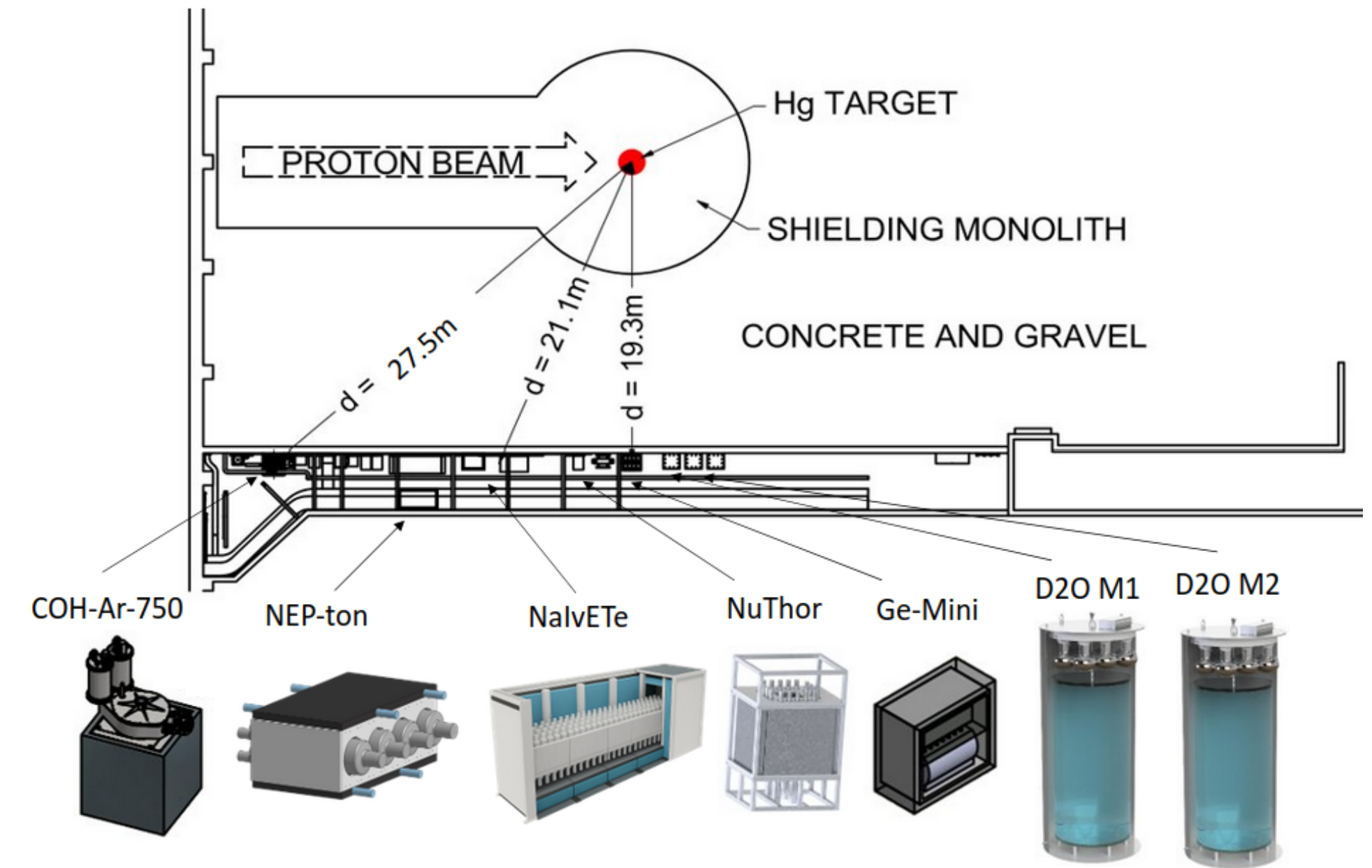

- ~120 members, 30 institutions
- Deployed 12 neutrino detectors
 - 5 now decommissioned
- 26 PhD theses
- 1,000+ neutrinos detected

Second Target Station (STS)

- Major facility upgrade, already started
 - First target station reached 2 MW
 - Additional 0.7 MW to STS (~2034)
- Unique opportunity for neutrinos at the SNS—2 neutrino sources, 2 baselines

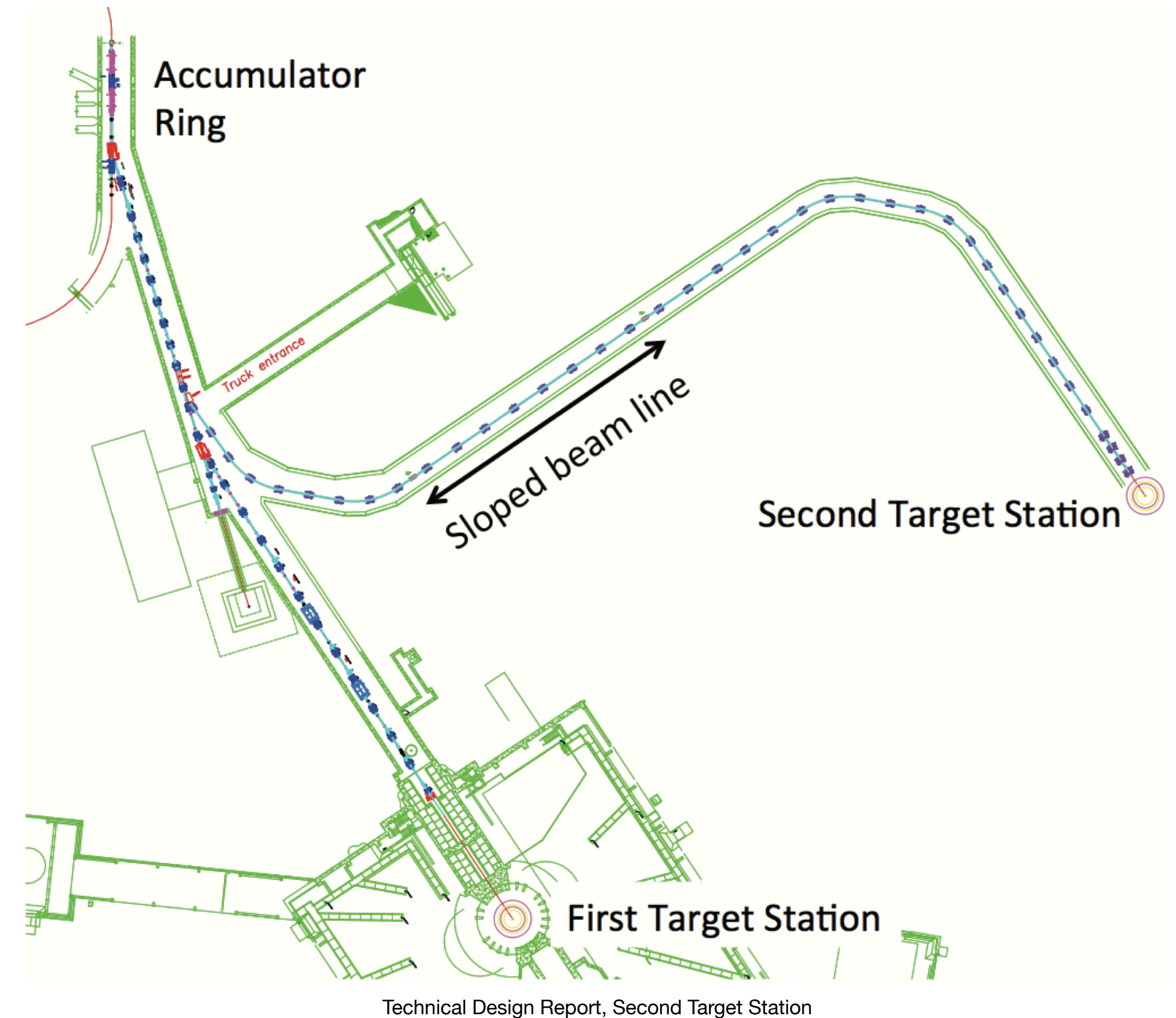

Summary

- COHERENT made first observation of CEvNS in 2017
- Moving toward the precision-era of CEvNS at the SNS through:
 - Additional targets
 - Increased statistics - larger detectors, lower thresholds
 - Improved analysis techniques
 - Reducing neutrino flux systematics w/D₂O detector
- Making full use of the SNS as a neutrino facility through charged-current scattering program
- **Lots of exciting results coming soon!**
- See poster presenters for more details

Acknowledgements



Office of Science



National Research Foundation of Korea

Accelerator-produced dark matter

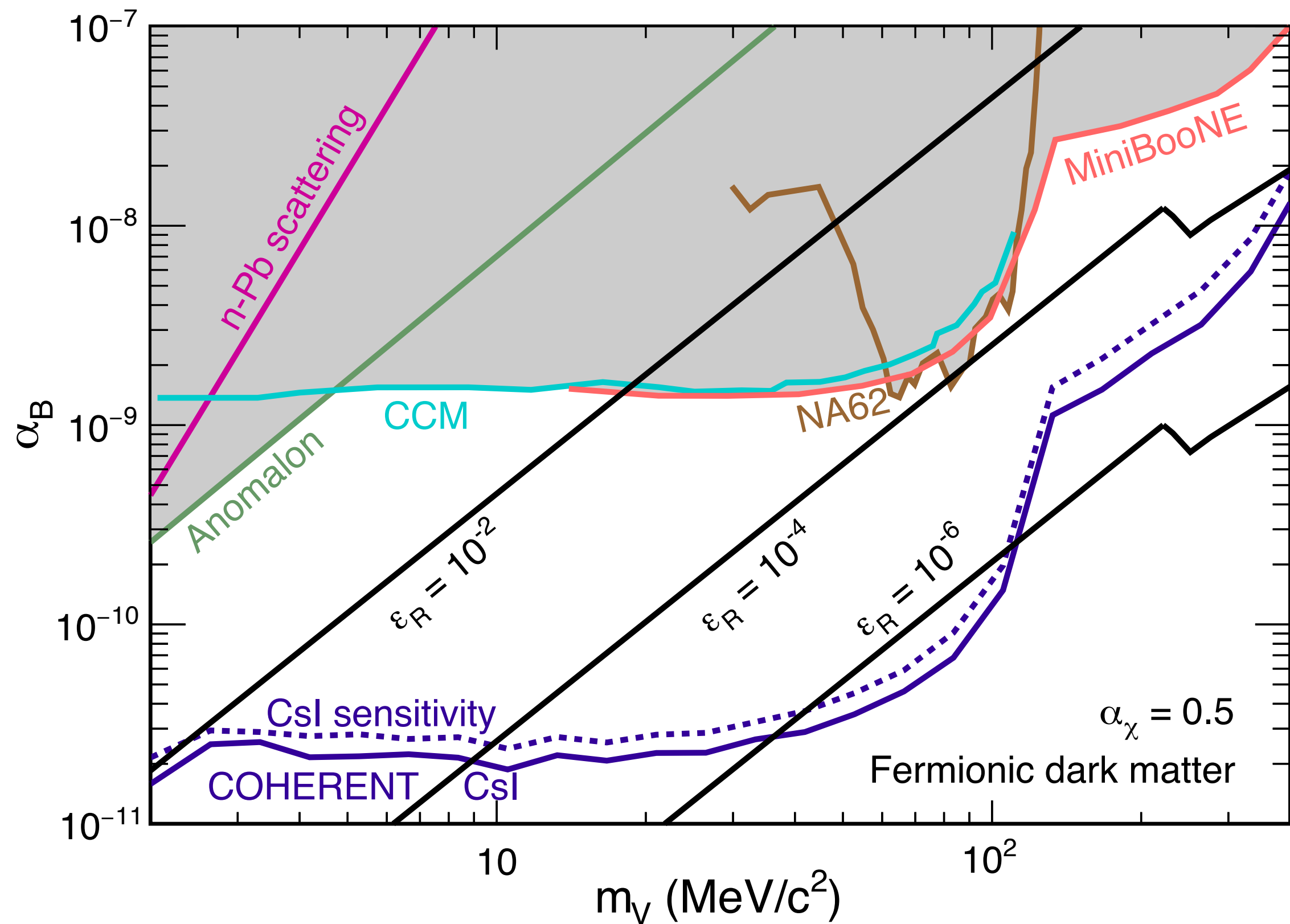

D. Akimov, et al., COHERENT, *Phys. Rev. D* **106**, 052004 (2022)

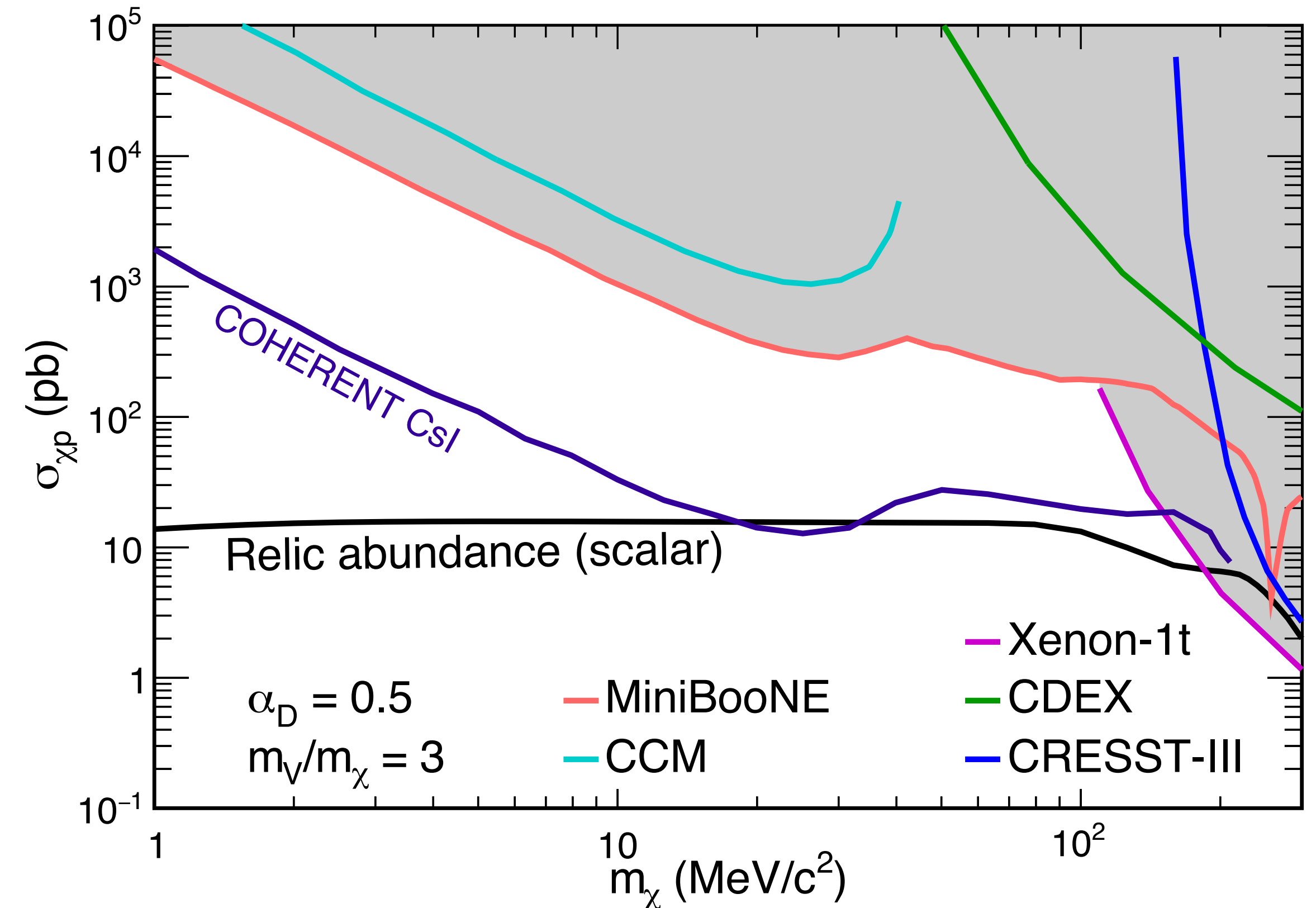

D. Akimov, et al., COHERENT, *Phys. Rev. Lett.* **130**, 051803 (2023)

TABLE I. Overview on subsystems for CEvNS detection.

Nuclear target	Detector Technology	Target Mass (kg)	Distance from source	Energy threshold (keV [†])	Deployment dates
CsI[Na]	Scintillating crystal	14	20 m	5	2015-2019
Ar	Single-phase LAr*	24	27.5 m	20	2016-2021
Ge	HPGe PPC [‡]	18	19.2 m	2.5	2022 - present
NaI[Tl]	Scintillating Crystal	3500	22 m	13	2022 - present
Ar	Single-phase LAr*	476	27.5 m	20	from 2026
CsI	CsI+SiPM arrays at 77 K	~6.4	20 m	~0.5	from 2026
CsI	CsI+SiPM arrays at 40 K	~10	20 m	~0.5	from 2027
Neon	Single-phase neon	~20	~15 m	<25	from 2026

Completed
Under deployment
Current
Planned

*liquid argon, fiducial volume stated, [‡]*p*-type point-contact, [†]nuclear recoil energy, approximate threshold

TABLE II. Additional detectors that broaden the physics reach of COHERENT.

Name	Detector Technology	Main purpose	Deployment dates
NaIvE	185 kg NaI[Tl] crystals	Measure ν_e + I CC cross section & beam-related backgrounds	2016 - 2024
NIN cubes	Liquid scintillator cells in lead and iron shields	Measure neutrino-induced neutrons (NIN) in lead & iron	2015 - 2022
MARS	Scintillation panels interleaved with Gd-painted foils	Measure beam-related neutrons in Neutrino Alley	2017 - present
NuThor	Th enclosed by NaI crystals and Gd-doped water brick	Measure neutrino-induced fission on thorium	2022 - present
D ₂ O M1	heavy water Cherenkov detector	Measure neutrino flux precisely & ν_e +O inelastic cross section	2023 - present
D ₂ O M2 (H ₂ O)	Light (\rightarrow heavy) water Cherenkov detector	Measure ν_e +O inelastic cross section	from 2026
NEP-ton (Pb glass)	Cherenkov radiation in Pb glass blocks	Determination of ν_e +Pb and ν_e +O inelastic cross section	2025-present
Pb sandwich	Pb sheets between scintillator panels	Directional ν_e CC on Pb detection, forbidden transitions	from 2026
H ₂ O	Light water Cherenkov detector	Dedicated ν_e +O inelastic cross sections	from 2026
LArTPC	Liquid argon time-projection chamber	Measure ν_e +Ar inelastic cross section	from 2026

Completed
Under deployment
Current
Planned

M. Adhikari, et al., COHERENT, *arXiv:2602.15652* (2026)