

FLArE: Forward Liquid Argon Experiment at the Forward Physics Facility

M. Vicenzi (mvicenzi@bnl.gov), Brookhaven National Laboratory, Upton, NY, 11973 on behalf of the FLArE Technical Working Group

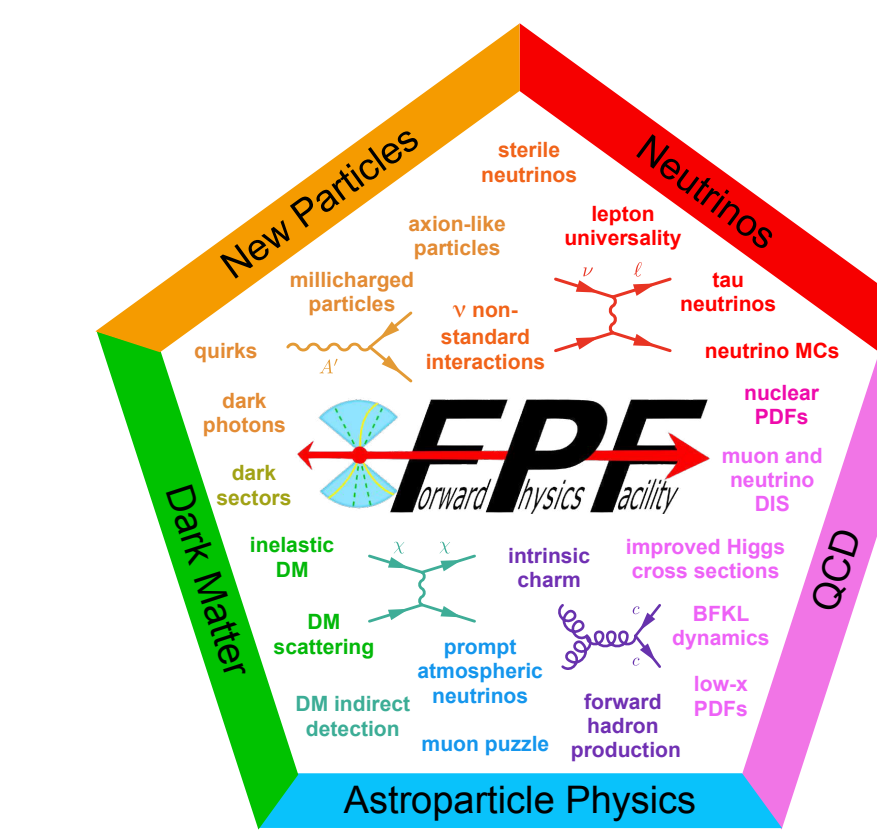

The Forward Physics Facility

The FPF is a proposed underground cavern 627 m downstream of the ATLAS interaction point, designed to exploit the intense flux of high-energy LHC collider neutrinos during the HL-LHC era.

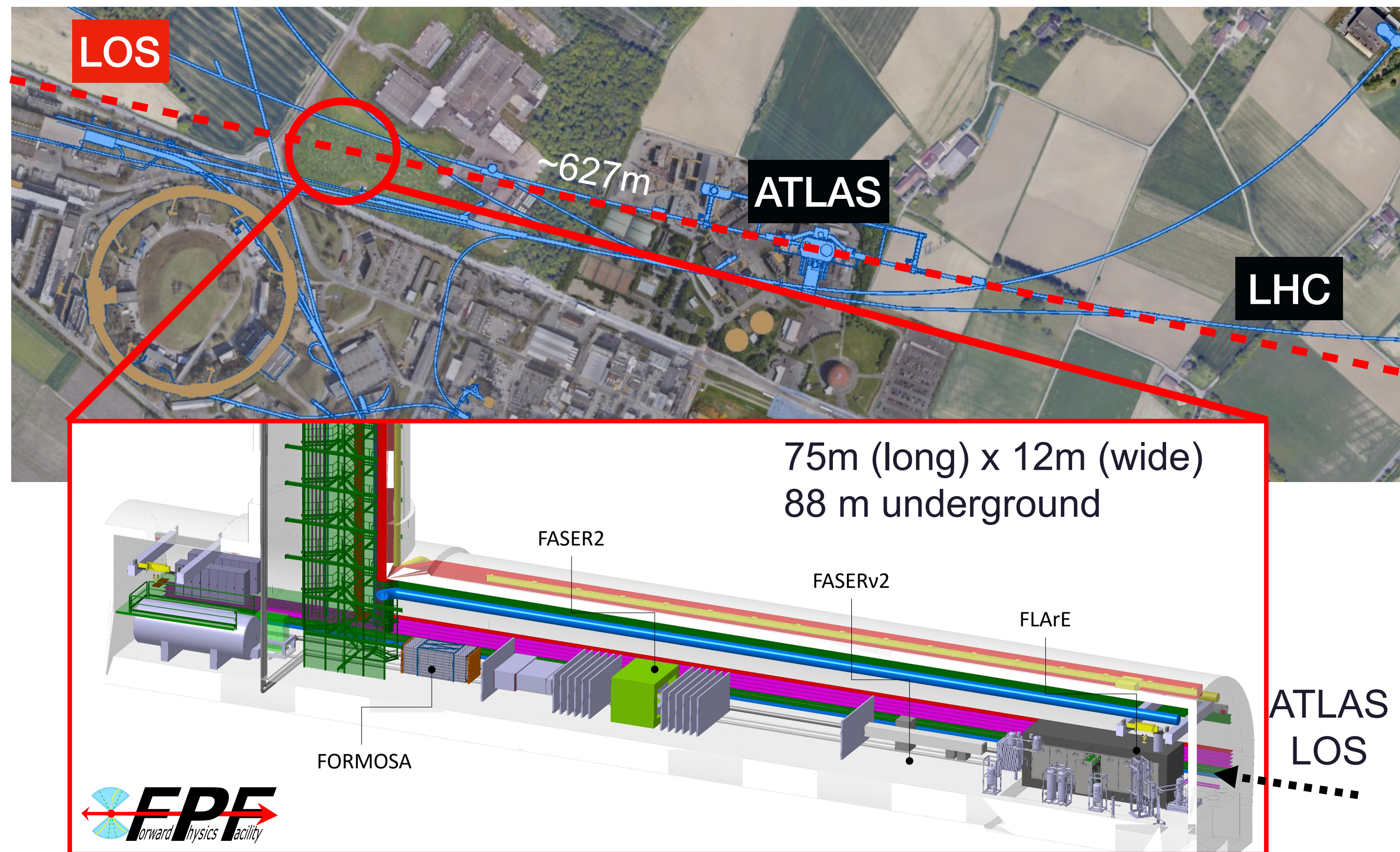

Forward Liquid Argon Experiment

FLArE is a modular liquid Argon time-projection chamber (TPC) proposed as one of the primary detectors for the FPF.

- **Broad energy range** (MeV to hundreds of GeV)
- **Wide pseudo-rapidity coverage** ($\eta > 7.5$)
- **Fast timing and low thresholds** (tens of MeV)

Intense flux of all 3 neutrino flavors: bridge gap between accelerator and atmospheric data!

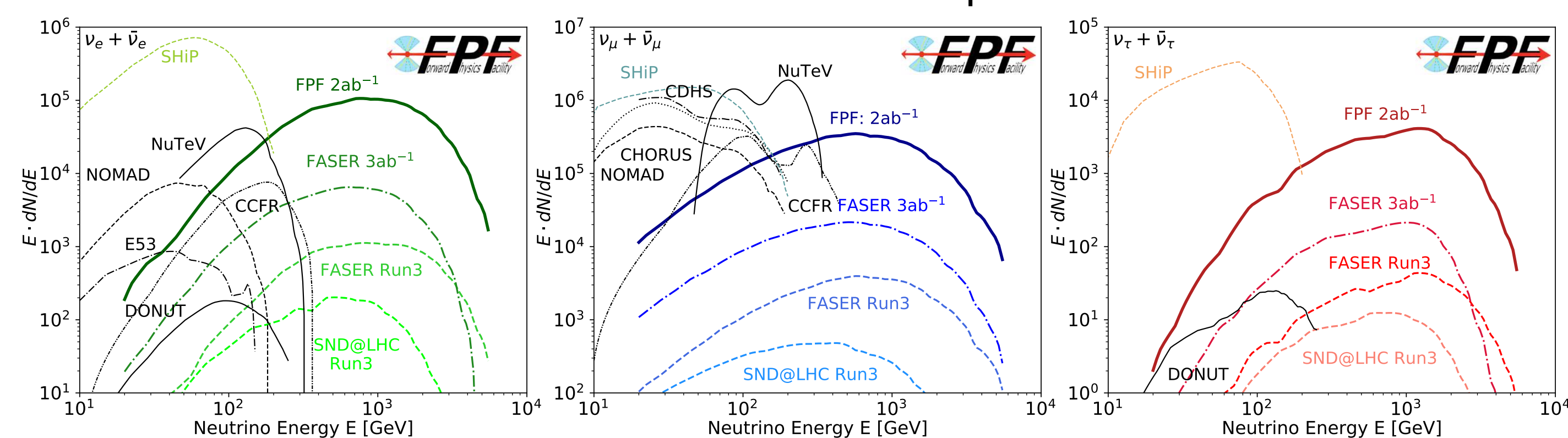

Probe forward production in pp-collisions (soft QCD), including charm contribution

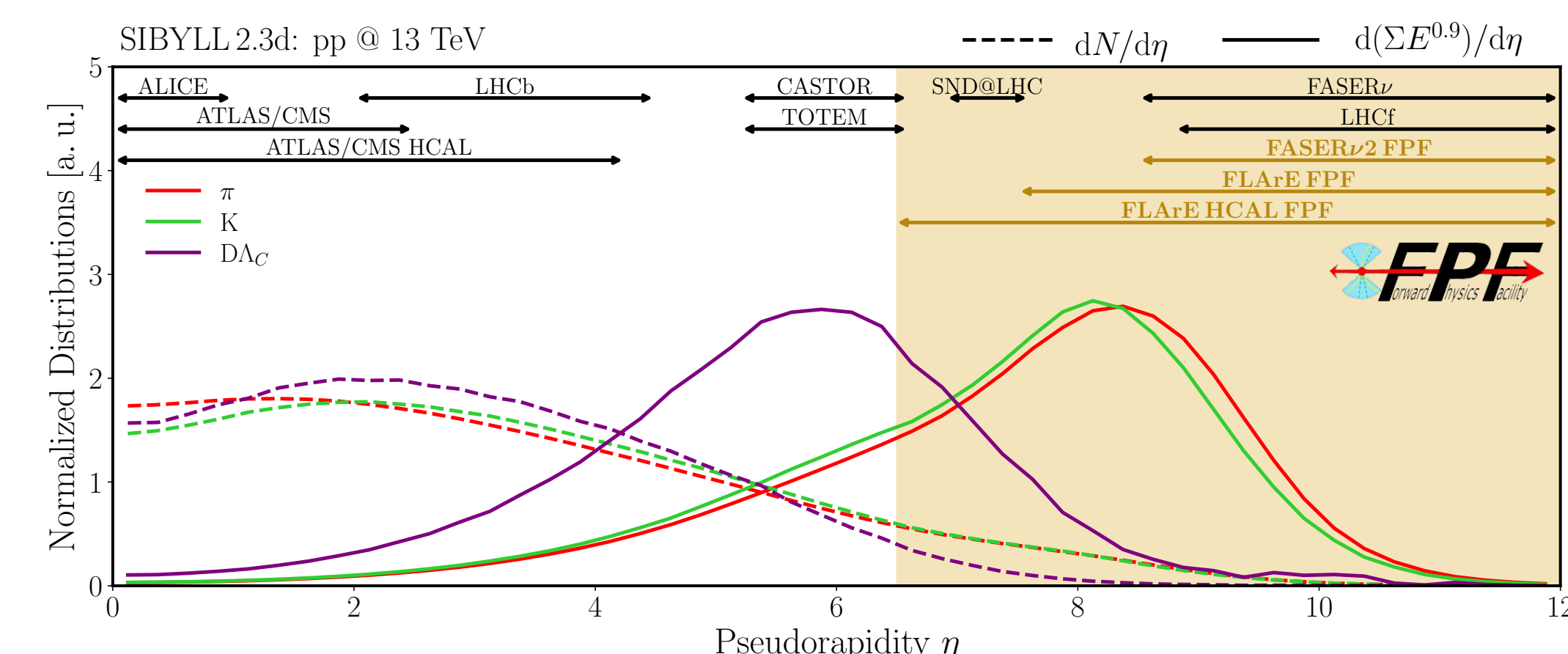

Neutrinos and precision SM physics

CC rate @ FLArE: ~ 10 events/ton/fb⁻¹ (1 day ~ 1 fb⁻¹ for HL-LHC). For 2 ab⁻¹ integrated luminosity:

$$\nu_e + \bar{\nu}_e: 34.7k, \quad \nu_\mu + \bar{\nu}_\mu: 167k, \quad \nu_\tau + \bar{\nu}_\tau: 1.0k$$

Neutrino fluxes and cross-sections in 10²-10³ GeV range. Neutrinos carry information on hadron production mechanisms.

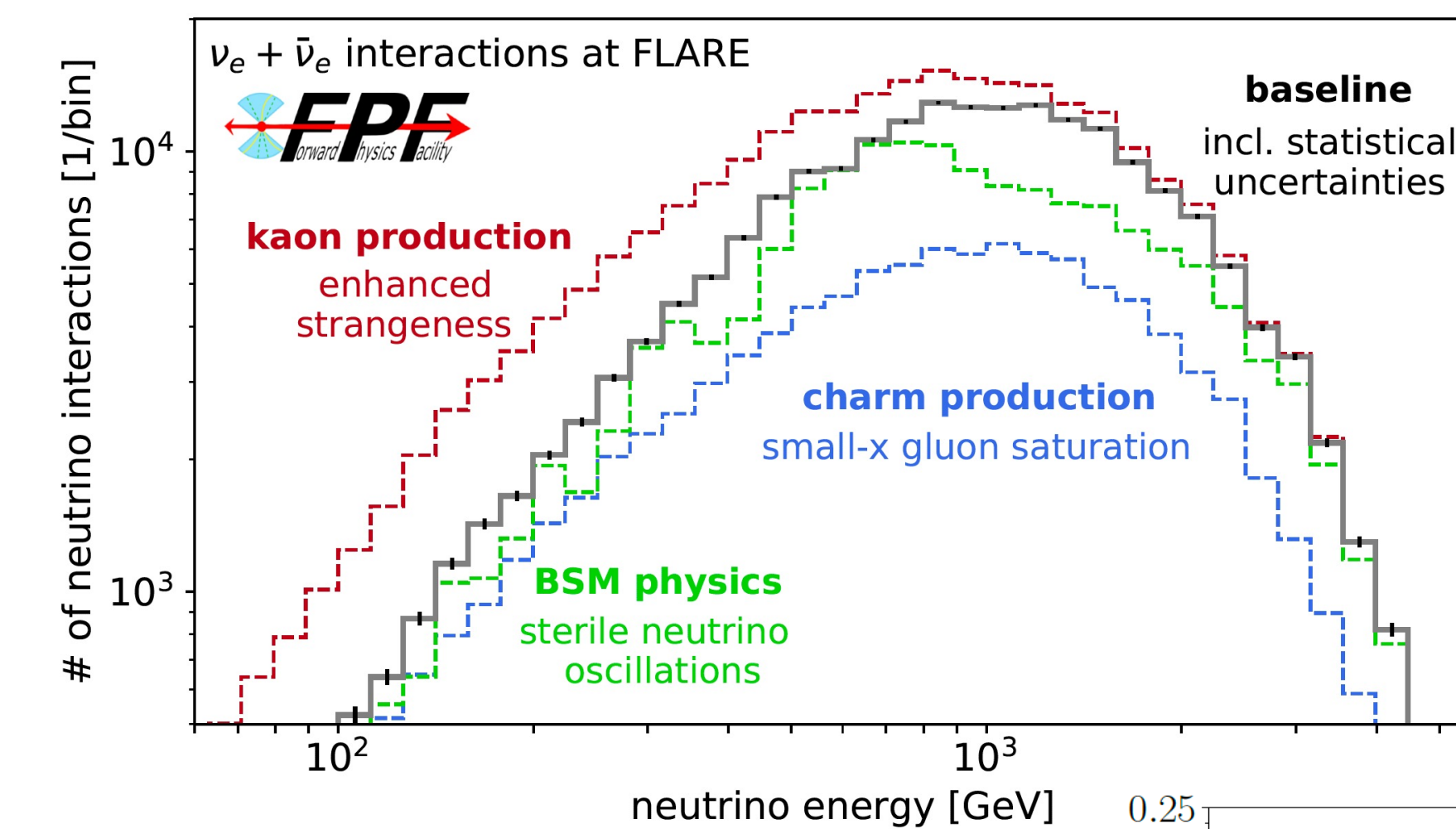

- ν_e flux sensitive to:
- K/ π ratio \rightarrow "muon puzzle" in EASs
 - Charm production (low-x QCD)

Extraction of clean NC sample allows measuring θ_W at O(10 GeV).

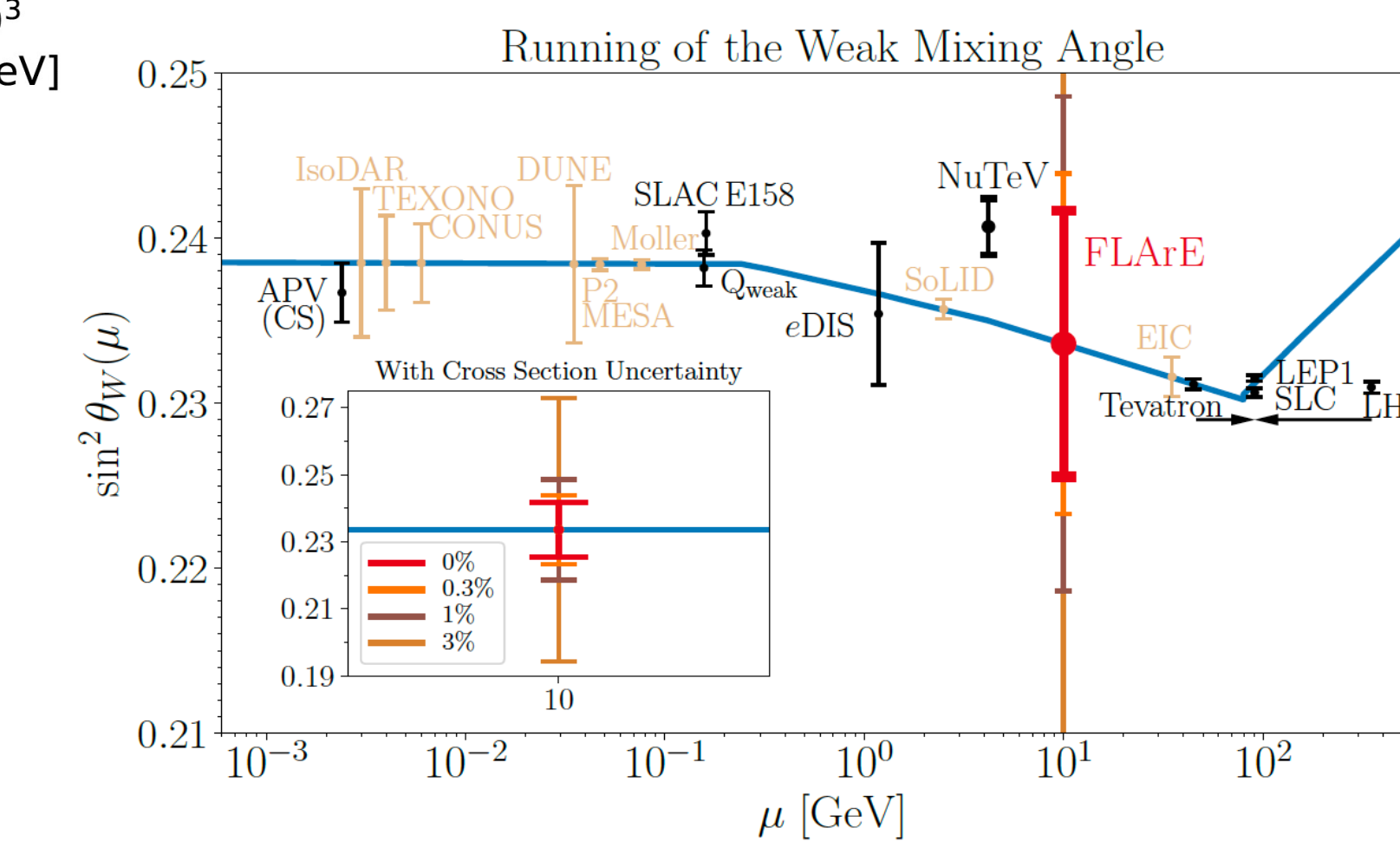

Dark Matter and BSM

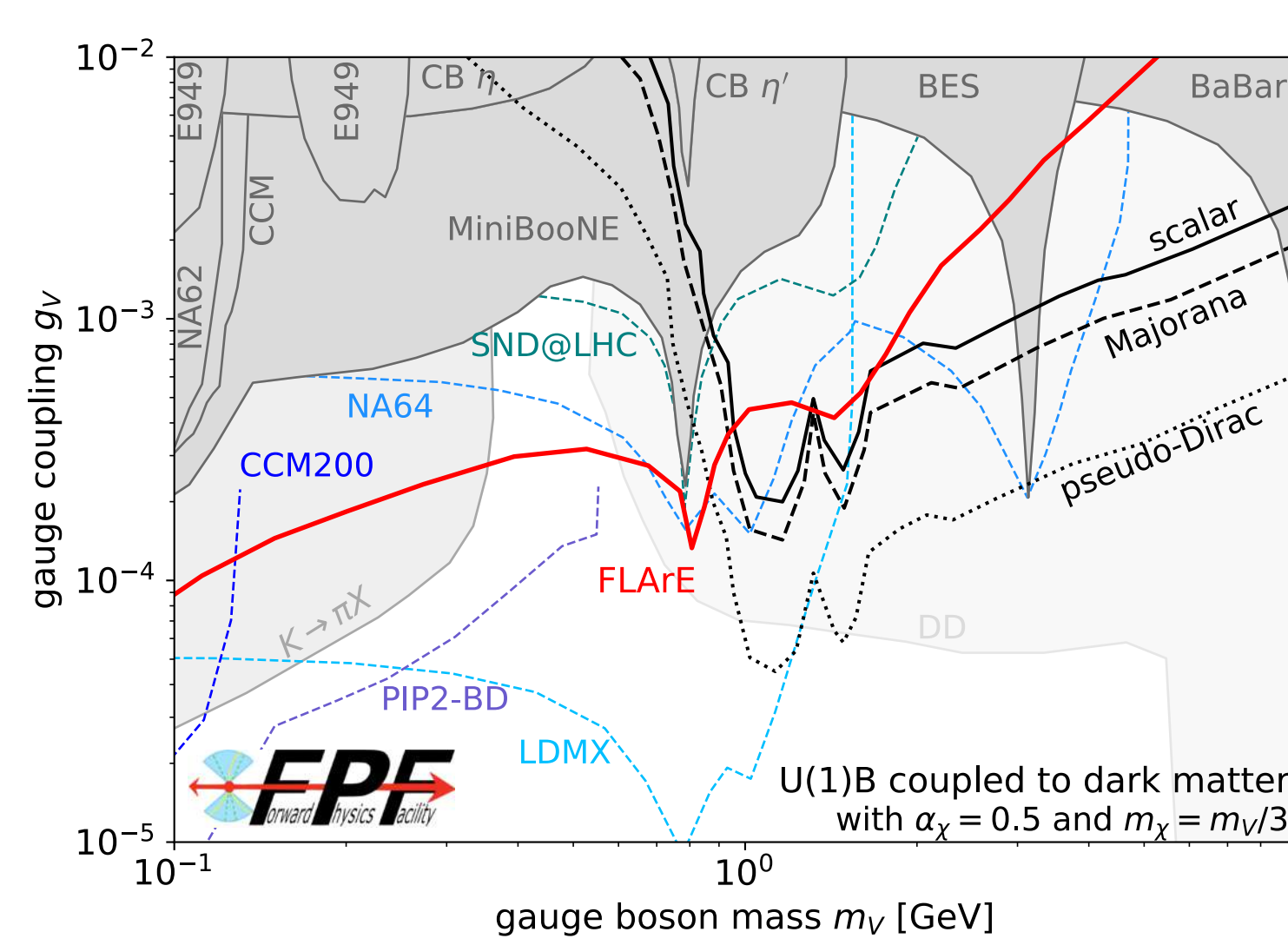

Low thresholds, precise timing resolution can be leveraged to search for light DM scattering.

Sensitivity to hadrophilic DM mediator signatures up to thermal relic target in GeV range.

Competitive sensitivity to neutrino's EM properties: world-leading bounds on ν_e charge radius, ν_τ charge and magnetic moment.

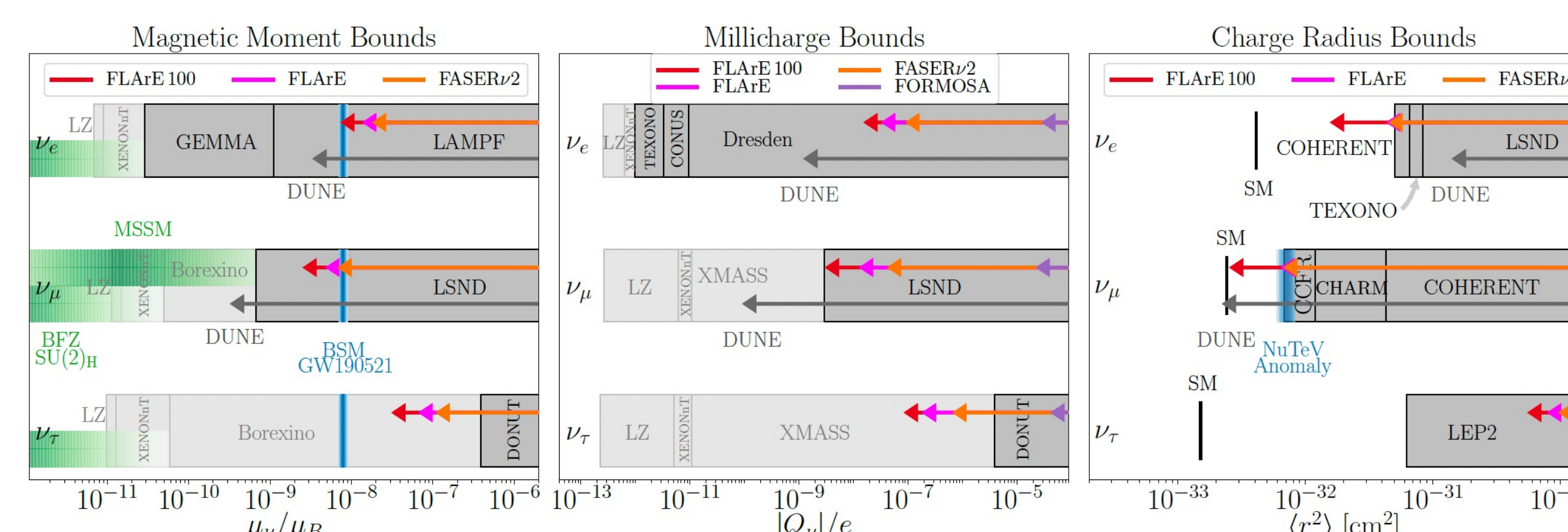

Cryostat and TPC design

Baseline: foam-insulated cryostat, "filing cabinet" concept. 10-ton fiducial, 30-ton active LAr volume (1.8 m x 1.8 m x 7 m).

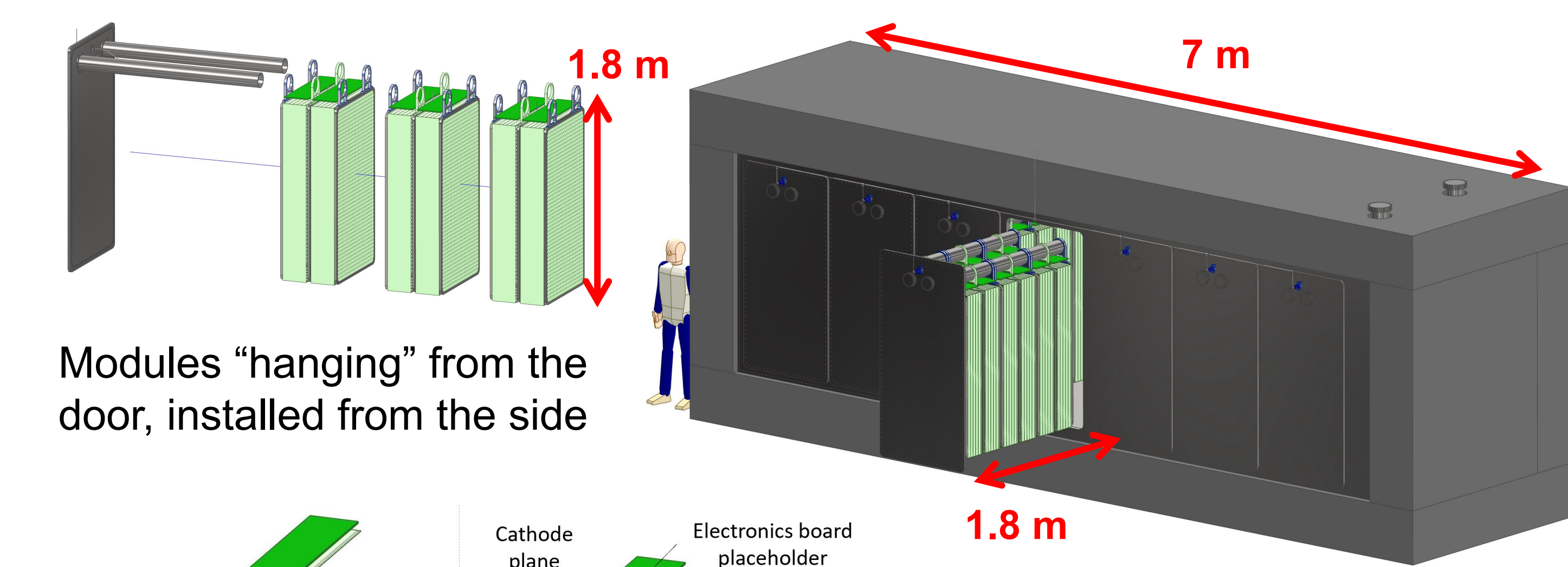

Modules "hanging" from the door, installed from the side

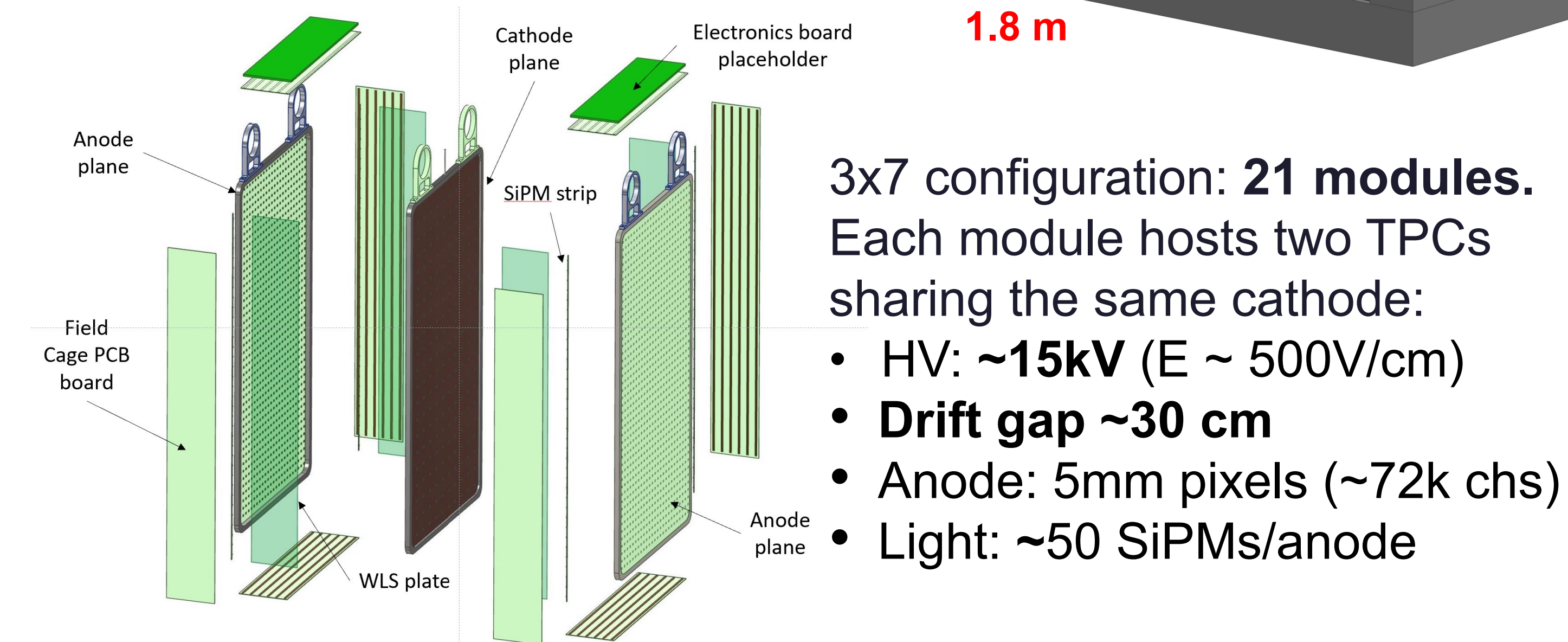

3x7 configuration: 21 modules. Each module hosts two TPCs sharing the same cathode:

- HV: ~ 15 kV ($E \sim 500$ V/cm)
- Drift gap ~ 30 cm
- Anode: 5mm pixels (~ 72 k chs)
- Light: ~ 50 SiPMs/anode

Background environment

Intense muon and muon-induced backgrounds correlated with bunch crossings at ATLAS IP despite ~ 200 m of rock/concrete.

< 0.5 Hz / cm² \rightarrow $< 1\%$ electric field distortions (space charge) in 30 cm gap.

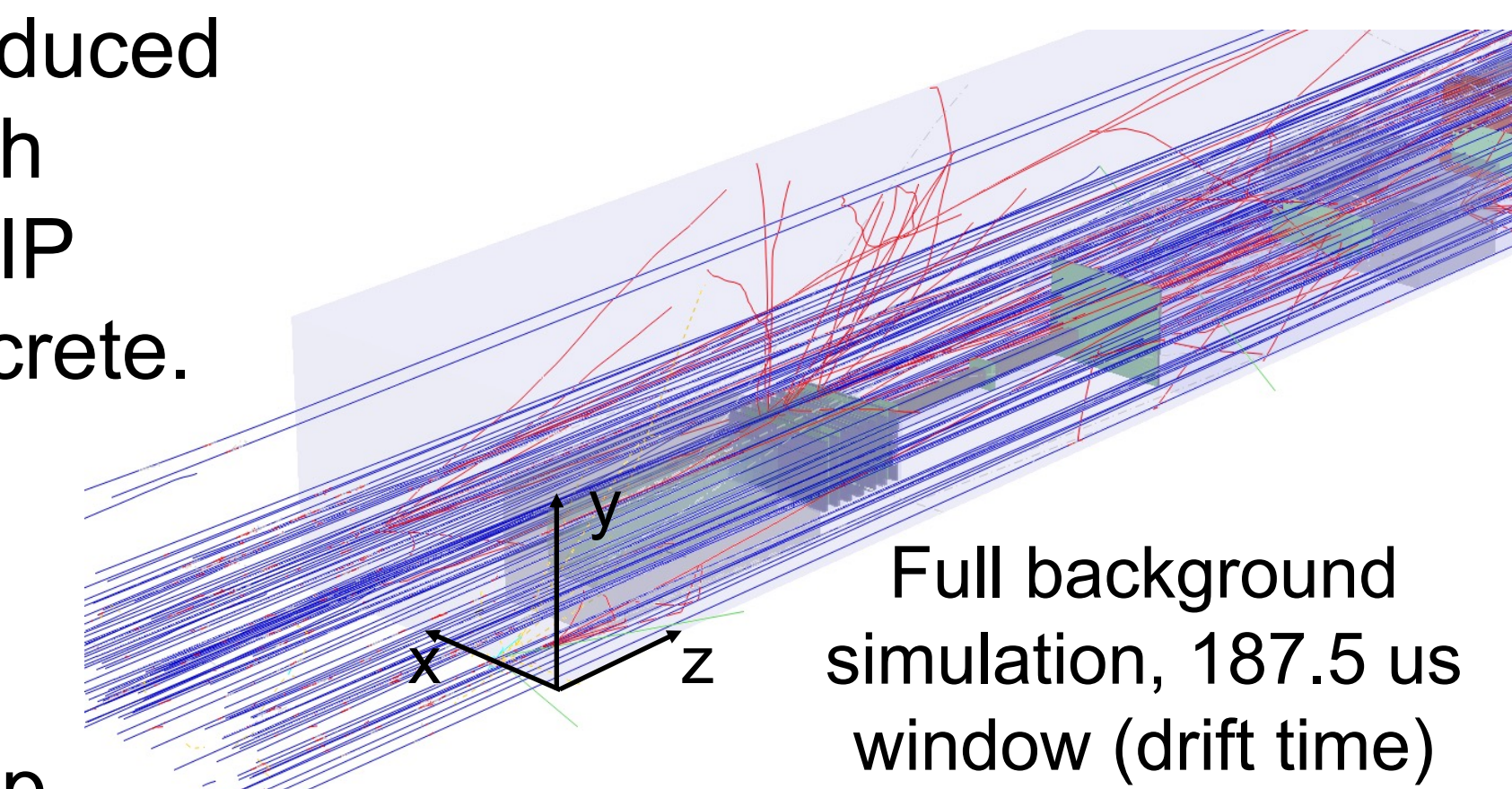

Full background simulation, 187.5 us window (drift time)

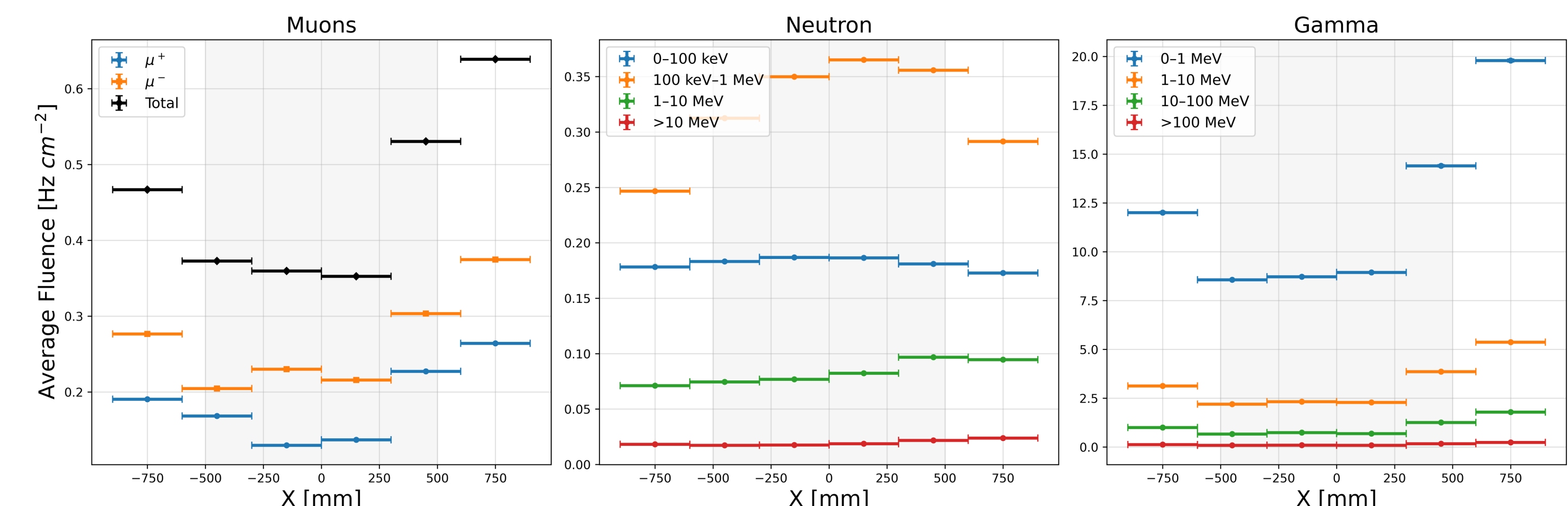

References

- [1] Nucl. Phys. B 1026 (2026) 117398, arXiv:2510.26260
- [2] Phys. Rev. D 111 (2025) 1, 015029, arXiv:2301.10254
- [3] CERN-PBC-Notes-2025-006
- [4] CERN-PBC-Notes-2025-007