

# Evaluating Position Dependence of Detection Performance for 50-cm Hyper-Kamiokande Photomultiplier Tubes

## Introduction

**Hyper-Kamiokande (HK)**, the successor to Super-Kamiokande (SK), aims to measure neutrino oscillation parameters, including the CP-violating phase and mass ordering with unprecedented precision. This is achieved through not only the large detector volume but also improved detector performance. The newly developed 50-cm photomultiplier tube (PMT) provides twice the detection efficiency and twofold improvements in both charge and timing resolutions compared to the conventional PMT used in SK.

## HKPMT (Hamamatsu R12860) and Box & Line dynode

**Box:** widely opened 1<sup>st</sup> dynode  
→ high collection efficiency  
**Line:** closely aligned 2<sup>nd</sup> to 10<sup>th</sup> dynode  
→ uniform electron path  
→ high resolution for time

The PMT response can depend on the electron trajectory, which is determined by:

- the light incident position,
- the high-voltage supply (HV), and
- the magnetic field (B-field).

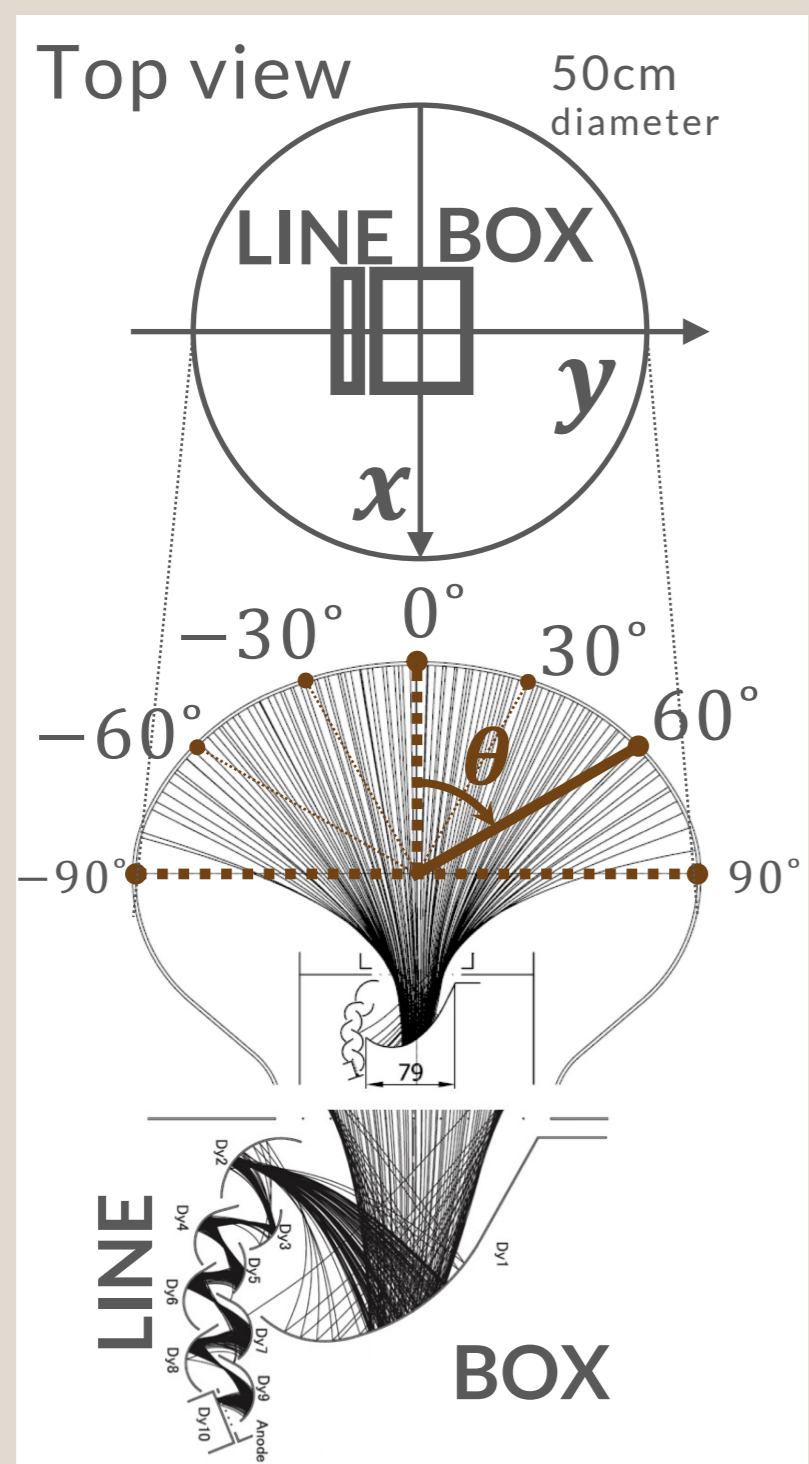

## Purpose

We measure the position dependence of the PMT response under varying HV and B-field conditions. The measurement is intended to **fully exploit the PMTs' potential and enable high-precision, unbiased event detection.**

## Method

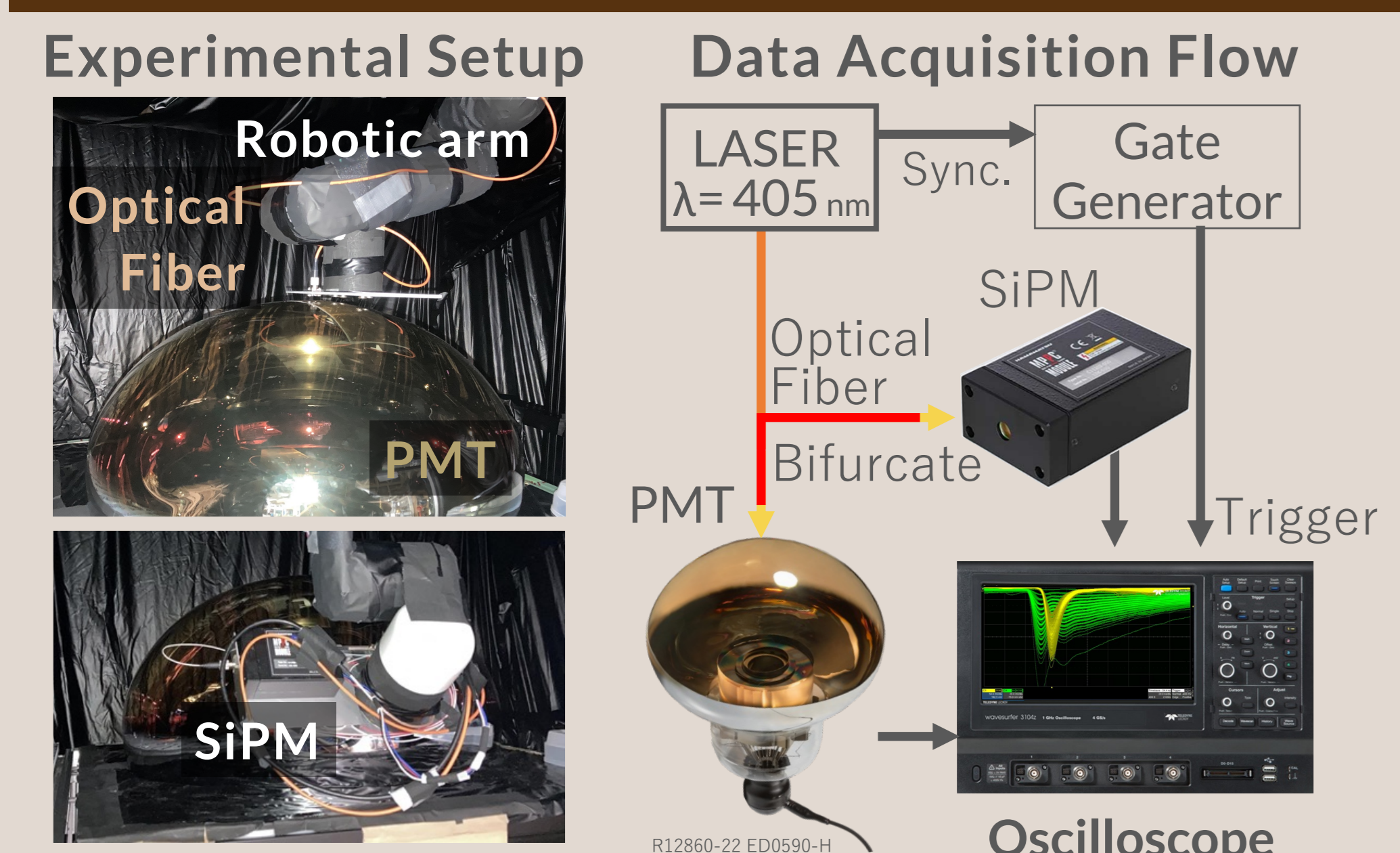

## Result

### Detection Timing for Single Photoelectron

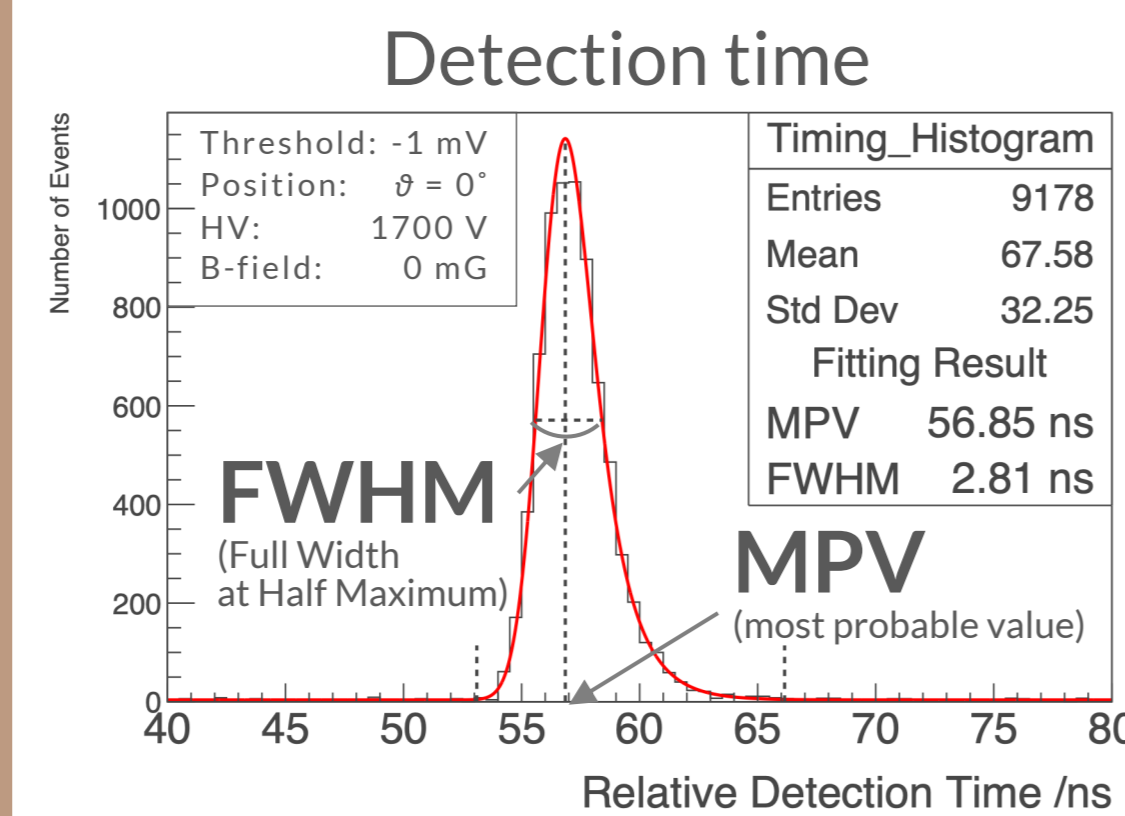

$$f(x) = N \frac{\lambda}{2} \exp\left(-2\lambda\left(x - \mu - \frac{\lambda\sigma^2}{2}\right)\right) \times \operatorname{erfc}\left(\frac{-(x - \mu - \lambda\sigma^2)}{\sqrt{2}\sigma}\right)$$

Model Function: Exponentially Modified Gaussian Function

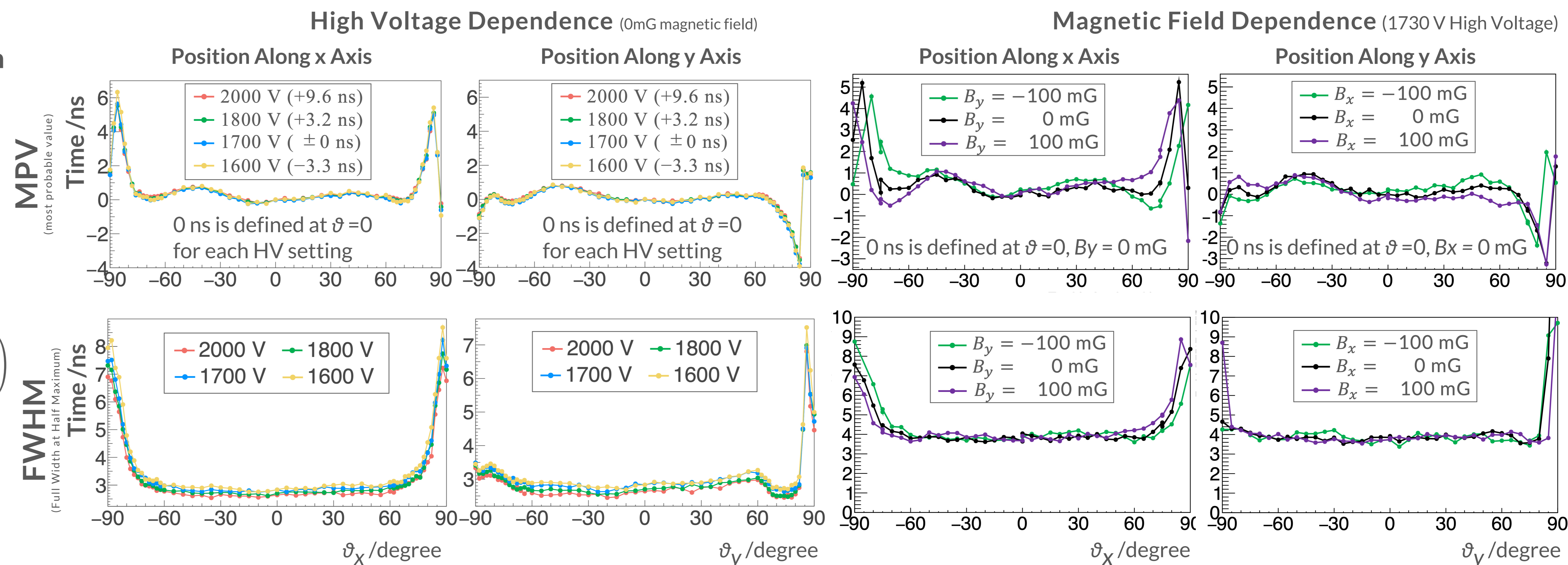

### Single Photoelectron Charge

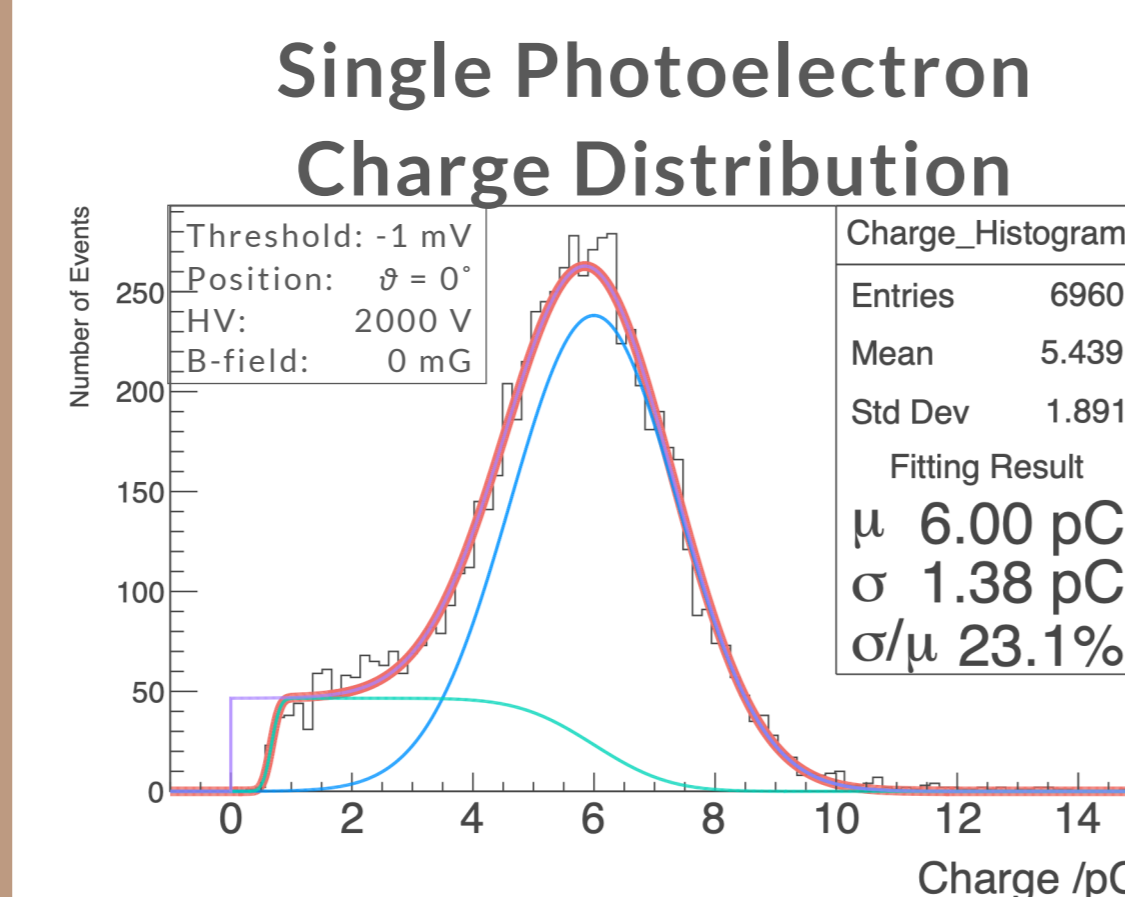

$$f(x) = P \exp\left(-\frac{1}{2}\left(\frac{x - \mu}{\sigma}\right)^2\right) + \frac{V}{2} \left( \operatorname{erf}\left(\frac{x - \mu'}{\sigma'}\right) - \operatorname{erf}\left(\frac{x - \mu}{\sigma}\right) \right)$$

Model Function: Gaussian function + error functions

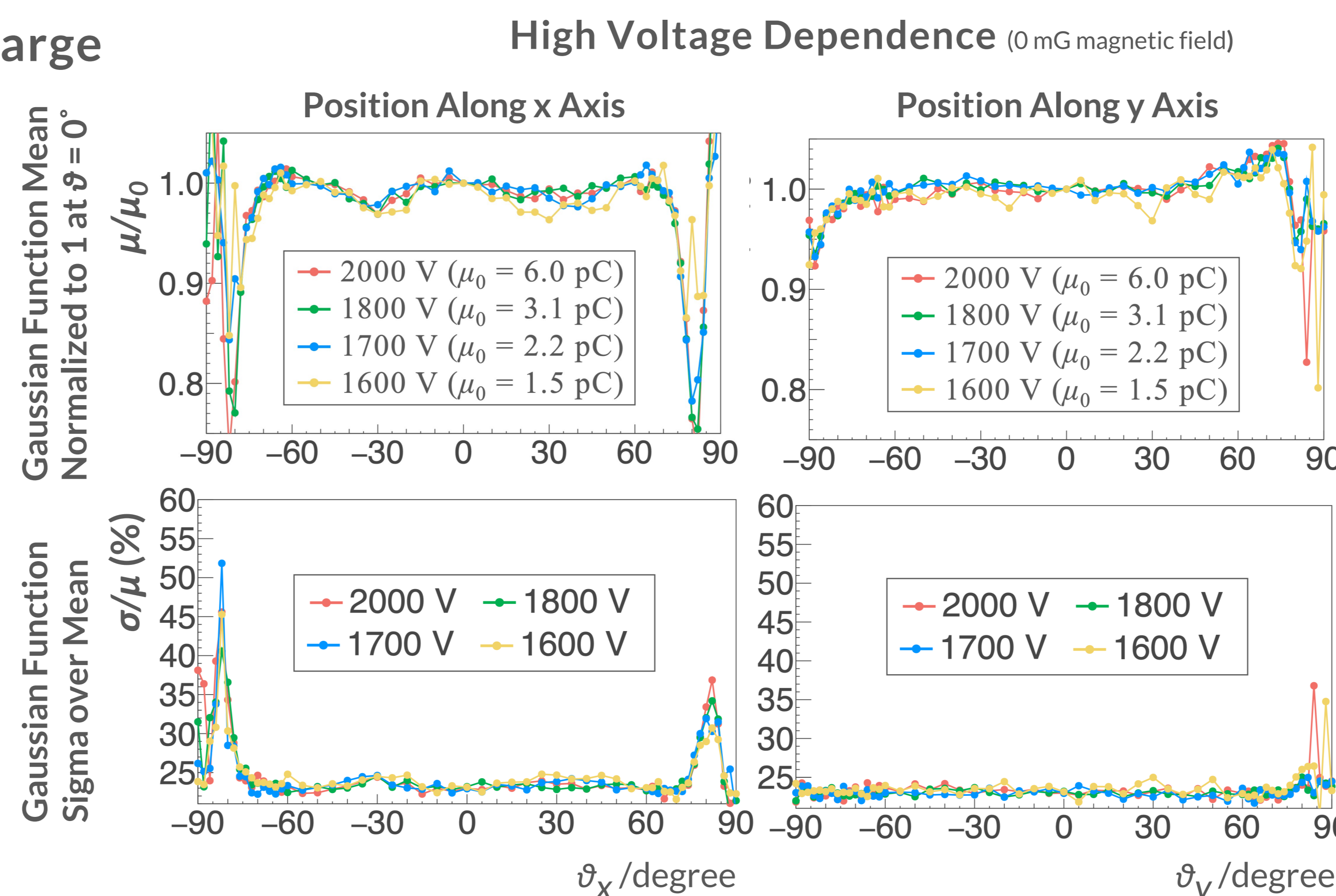

### Relative Detection Efficiency

$$\text{RDE} = \frac{N_{\text{PMT}}}{N_{\text{SiPM}}}$$

$$N_{\text{PMT}} = \frac{Q_N}{Q_1}$$

RDE: Relative Detection Efficiency  
 $N_{\text{PMT}}, N_{\text{SiPM}}$ : Number of photoelectrons detected by PMT and SiPM  
 $Q_N$ : Mean charge measured simultaneously with SiPM  
 $Q_1$ : Mean charge from single photoelectron measured in advance

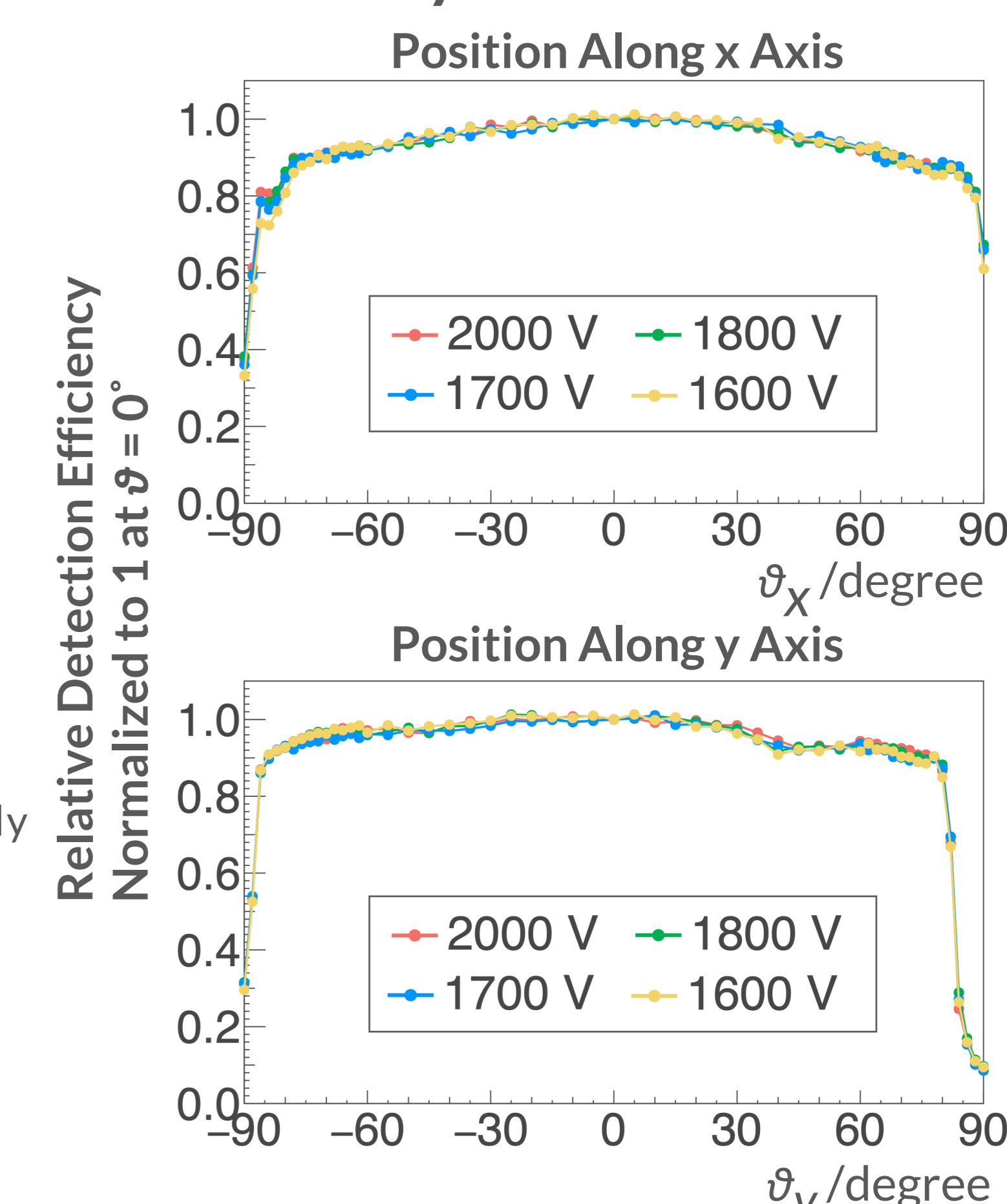

## Summary and Future Prospect

- We established a scanning system and measured position dependence.
- After appropriate offset or scale corrections, no significant HV dependence remains in the position dependence of the detection time, charge, or efficiency.
- The results will be modeled so that they can be incorporated into the simulation and/or reconstruction.
- We will continue to measure the dependences on position in more detail, and further investigate the individual differences among PMTs. The right figures are examples of the 2-D scanning currently under analysis.

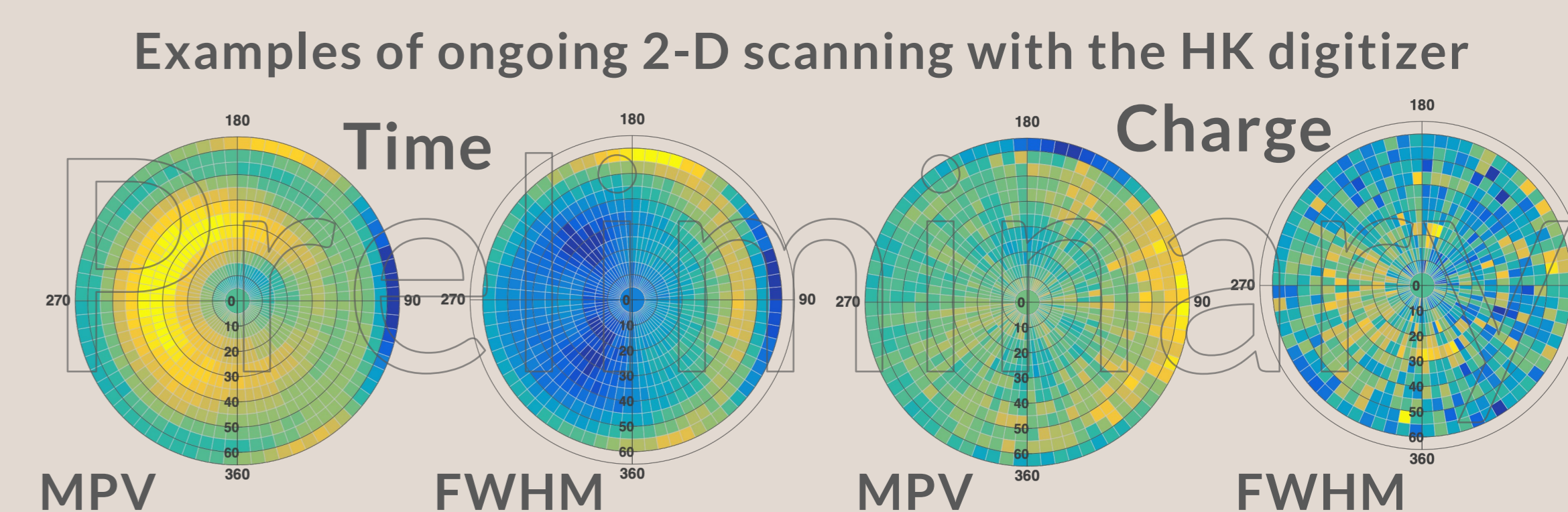

\*Helmholtz coils surround the entire setup to control the B-field.