

# The QuIPS Experiment

## Progress toward a sterile neutrino search with optically-levitated nanospheres

Clarke A. Hardy\*, Yu-Han Tseng, Jacqueline Baeza-Rubio, T. W. Penny, and David C. Moore  
Wright Laboratory, Department of Physics, Yale University

### Introduction

The **Quantum Invisible Particle Search** collaboration plans to use optically-levitated nanospheres doped with radionuclides to conduct a **recoil-based** search for sterile neutrinos produced in  $\beta$  and EC decays.

**Technique:** reconstruct  $\vec{p}_\nu$  event by event and search for a **low-momentum excess** due to heavy ( $\sim$ keV–MeV) sterile  $\nu$  emission.

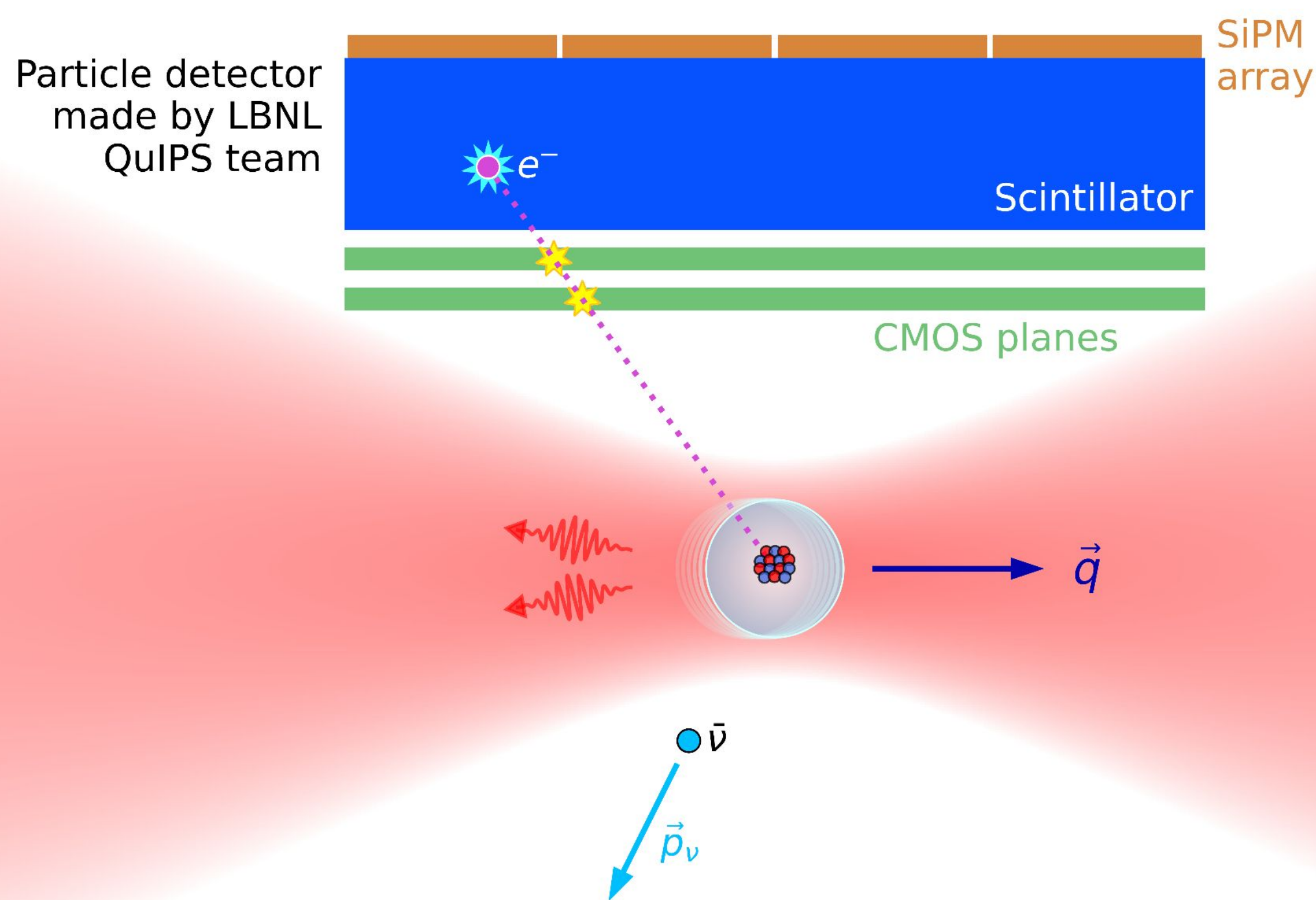

### Experimental Setup

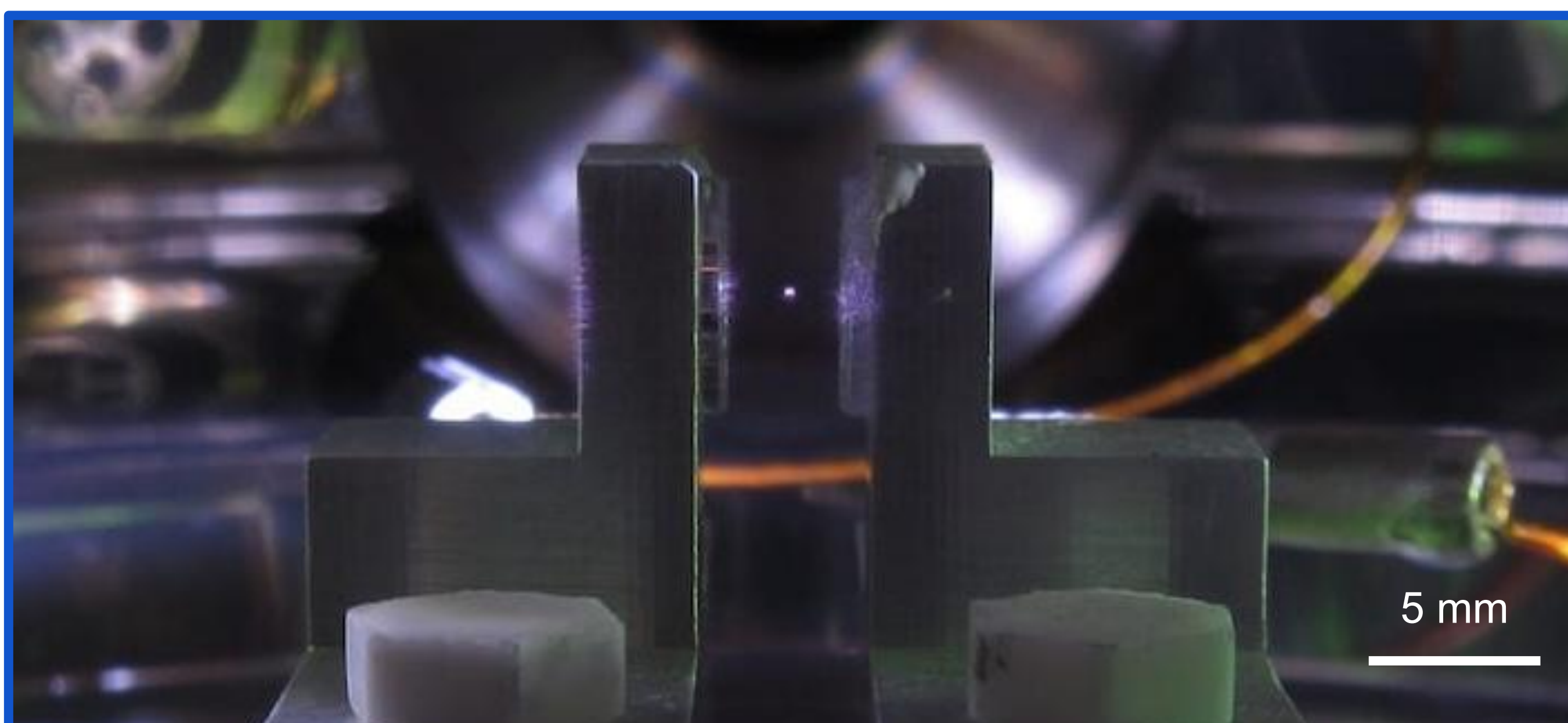

- Optical tweezer trap using tightly-focused (NA=0.77) 1064 nm laser [1]
- Center of mass motion cooled to  $\sim$ 10 mK with optical parametric feedback
- Single- $e$  charge control with UV laser and thermionic filament
- Particle position measured interferometrically from phase of backscattered light

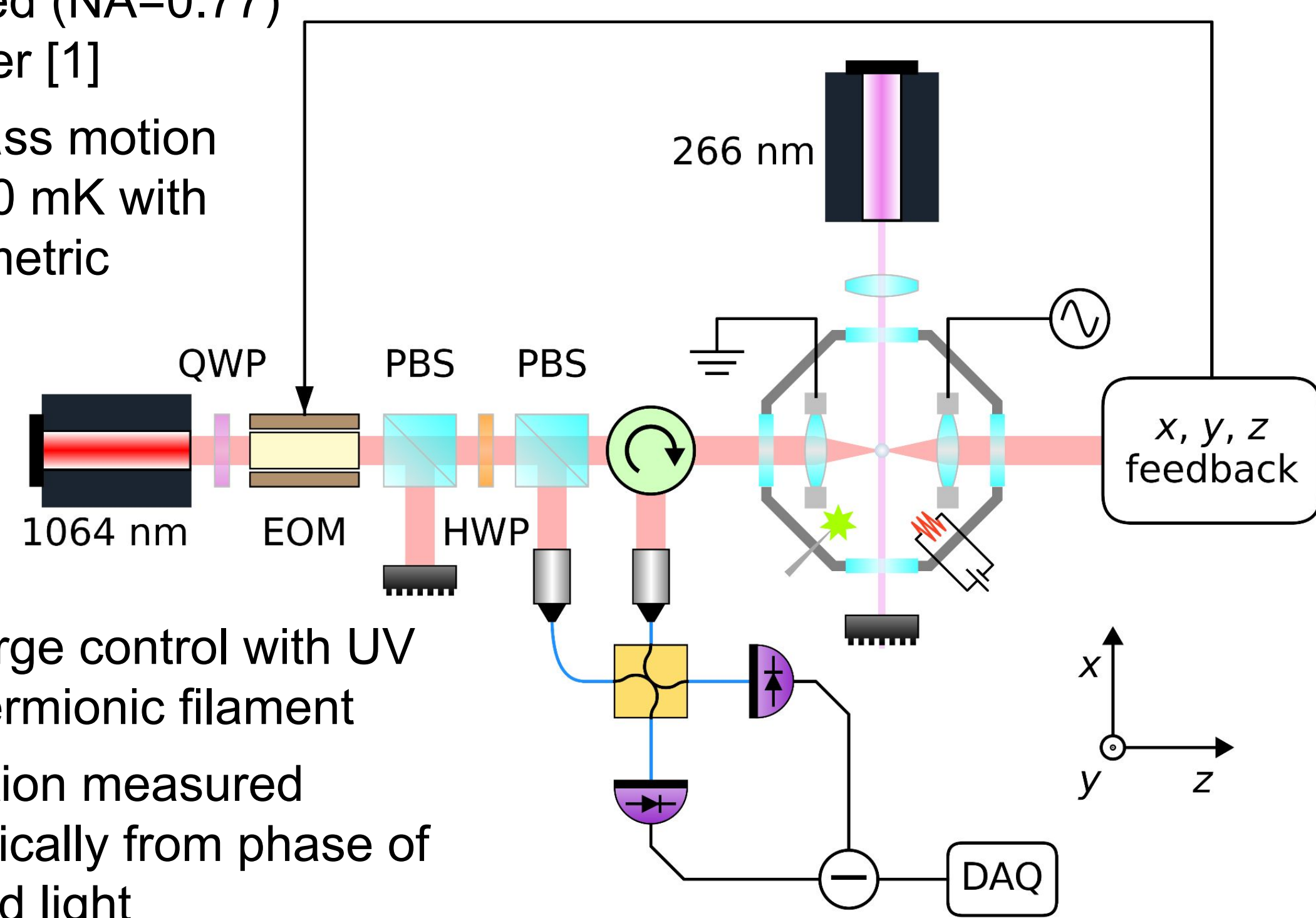

### Impulse Sensing

An optically-trapped nanosphere in ultra-high vacuum acts as a lightly-damped harmonic oscillator with  $\omega_0/2\pi \sim 50$  kHz

Impulse sensing is **quantum limited**, with noise from

- Imprecision (photon shot noise)
- Backaction (photon recoil heating) and above  $\sim 10^{-7}$  mbar
- Gas collisions

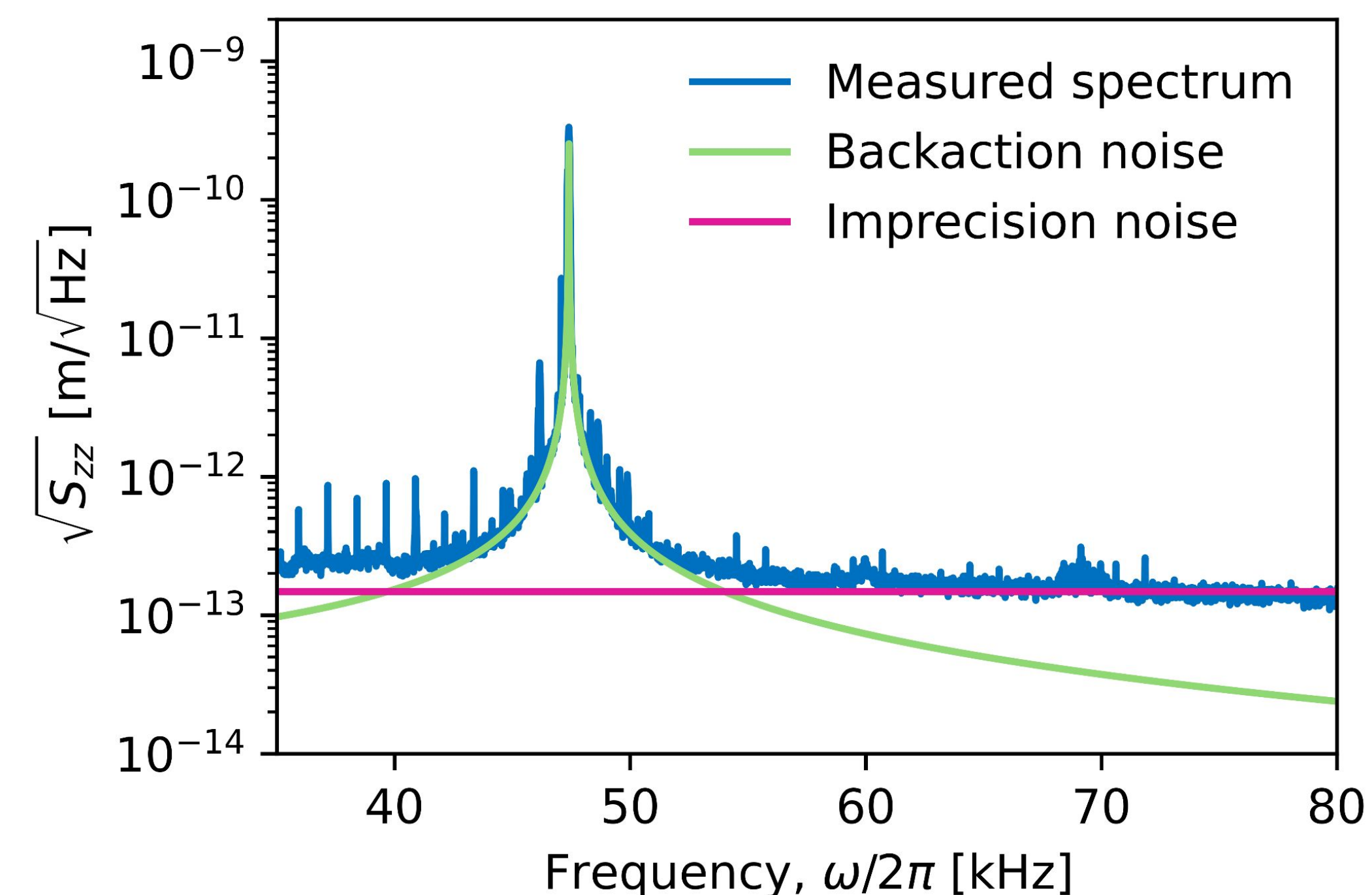

#### Calibration

- Deliver impulses electrically to a charged sphere by pulsing a lens holder
- Demonstrated momentum sensitivity of **< 50 keV/c** to electrical impulses

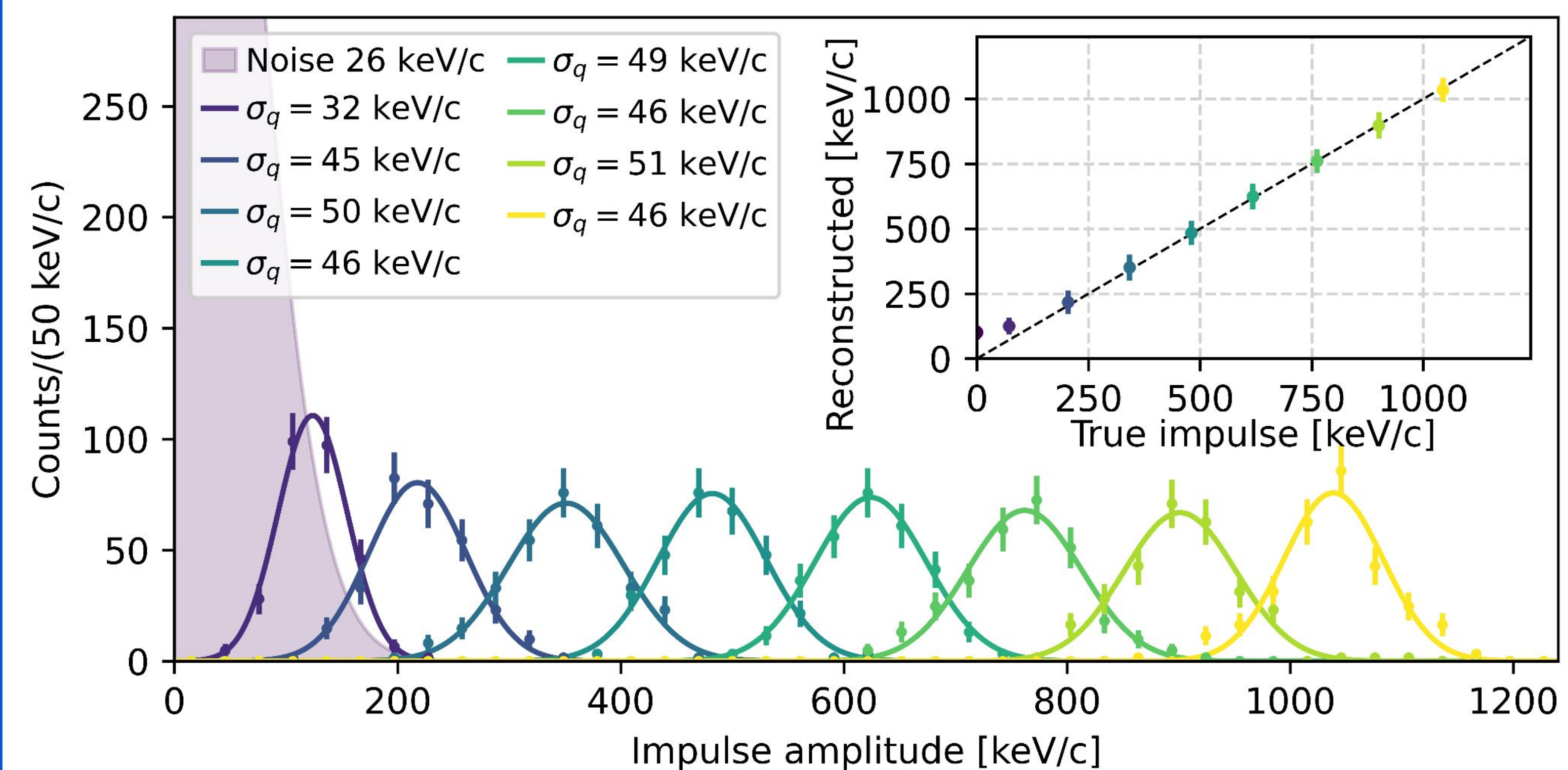

#### Impulse reconstruction

- Short ( $t < 1/\omega_0 \sim 3 \mu$ s) interactions look like instantaneous kicks causing a change in the amplitude of oscillation
- **Impulse** can be reconstructed from **position** data using an **optimal filter**
- Validated with both electric calibrations and detection of **collisions from individual gas molecules** – see our recent paper! [2]

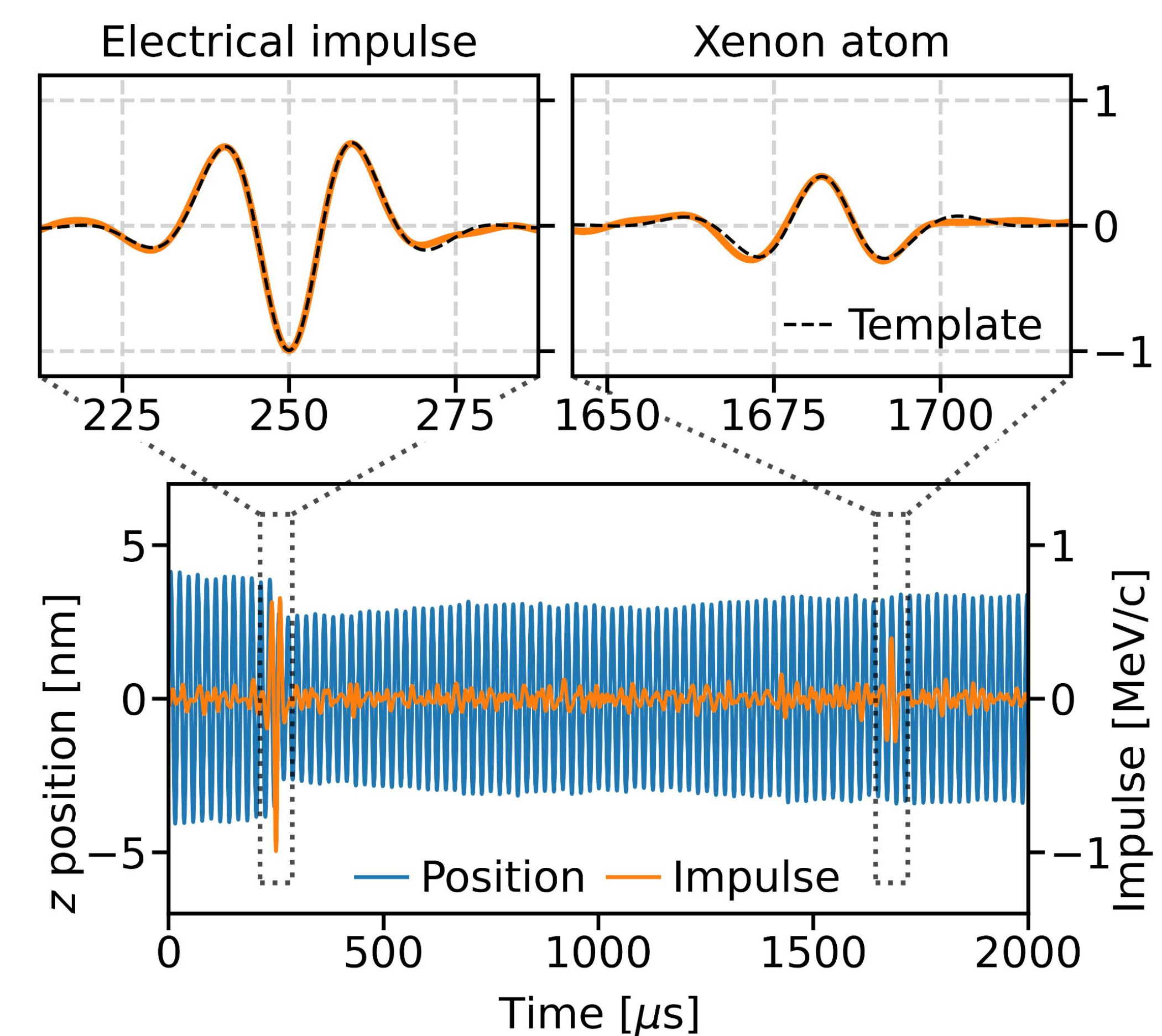

### Status & Prospects

#### Current status

- Trapping by nebulizing solution of nanospheres into the chamber
- Working towards deterministic loading of individual radioactive spheres to prevent contamination of the chamber with radioactivity
- Nanosphere loading pipeline (in progress):

Inkjet  $\rightarrow$  Paul trap  $\rightarrow$  RF guide  $\rightarrow$  optical trap



#### Projected sensitivity

Sensitivity computed for 30 simulated live-days with a 100 nm silica sphere doped to 1% by mass and replaced once per half life [3]

Projected sensitivity using  $\beta$  decaying (solid) and EC (dashed) isotopes

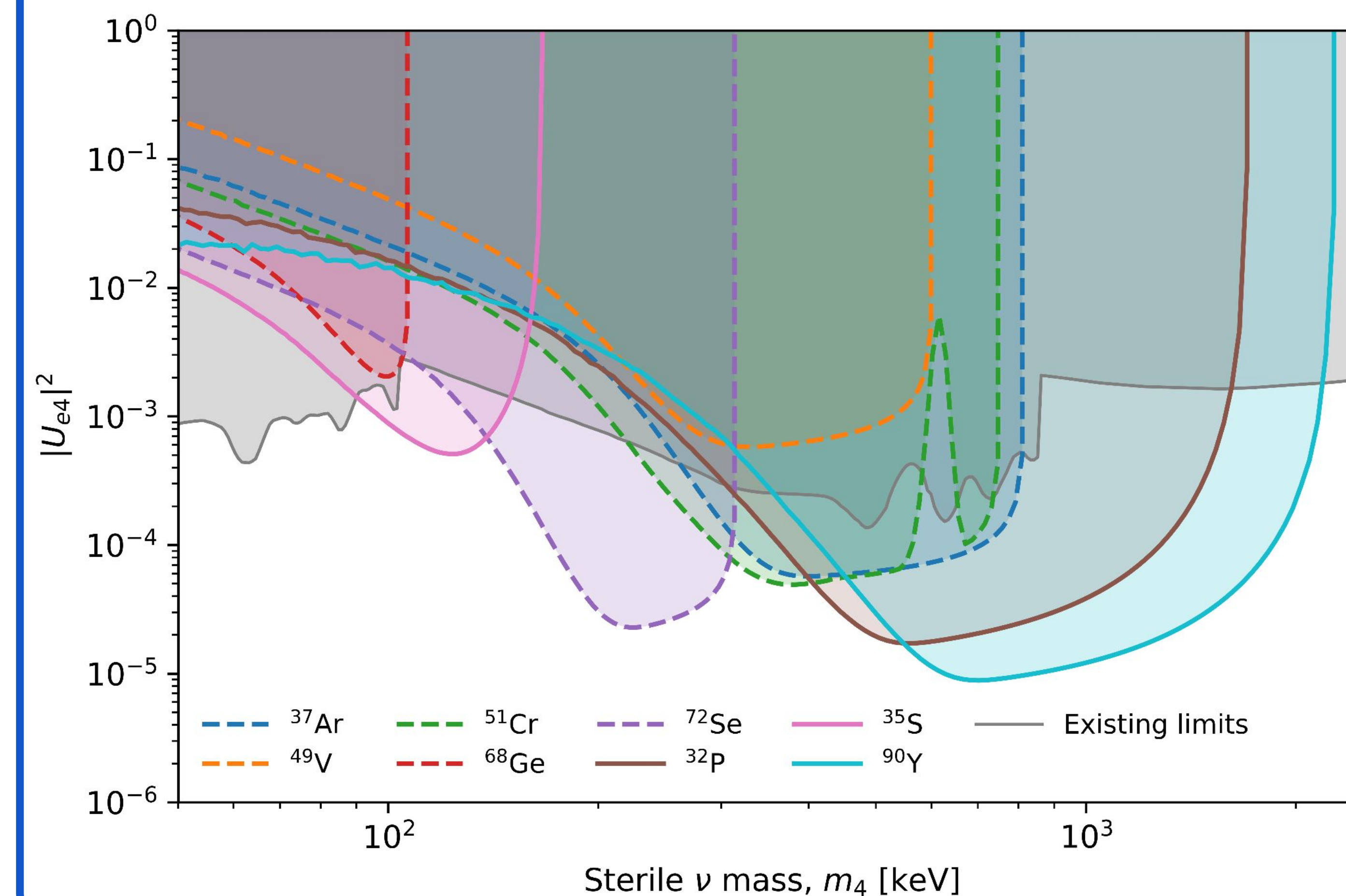

### Summary

- $\rightarrow$  Demonstrated impulse sensitivity of 50 keV/c
- $\rightarrow$  Detected collisions of individual gas molecules for the first time
- $\rightarrow$  Efforts underway to deterministically trap radioactive nanospheres
- $\rightarrow$  First sterile neutrino search in the next 1–2 years

#### References

- [1] Tseng *et al* PRX Quantum **6**, 040367 (2025)
- [2] Tseng *et al* (2026) [arXiv:2604.18371]
- [3] Carney *et al* PRX Quantum **4**, 010315 (2023)

\*Contact: clark.hardy@yale.edu

#### Collaborating institutions

