



First observation of quantum reflection of atomic hydrogen from a silicon surface on the journey toward the first demonstration of gravitational quantum states of atoms

Carina Killian on behalf of the GRASIAN collaboration

20.05.2026

Gravitational quantum states (GQS)

Gravitational potential well ↔

Gravity potential + Reflecting surface

- GQS of hydrogen
 - Macroscopic spatial heights $z_n \sim \mu\text{m}$
 - Eigenenergies $E_n \sim \text{peV} \rightarrow$ Heisenberg's uncertainty:

$$\Delta t \Delta E \geq \frac{\hbar}{2} \rightarrow \Delta t \gtrsim 0.5 \text{ ms}$$

- 2002: First demonstration of GQS with ultra cold neutrons [1], so far no measurements with neutral atoms.

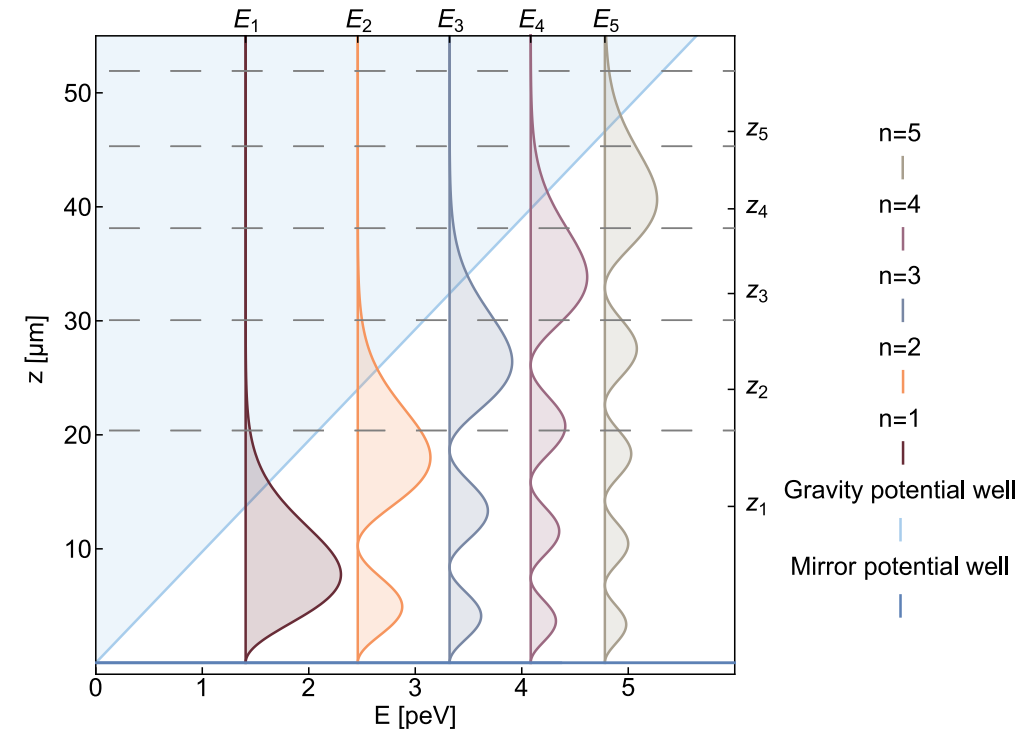

n	E_n [peV]	z_n [μm]
1	1.4	13.8
2	2.5	24.0
3	3.3	32.4
4	4.1	39.9
5	4.8	46.6

Eigenenergies and spatial heights of the first 5 GQS of hydrogen with $m_H = 1.6735575 \times 10^{-27} \text{ kg}$, $g = 9.81 \text{ m/s}^2$, $V_{\text{mirr}} = \delta(z)$

Measurement principle

- GQS spectrometer: Si mirror and scatterer separated by a slit (Δz)
- Variation of the slit width Δz
- Measurement of the hydrogen count rate N as a function of Δz
- When stepwise increase of N is measured \rightarrow **Demonstration of GQS**

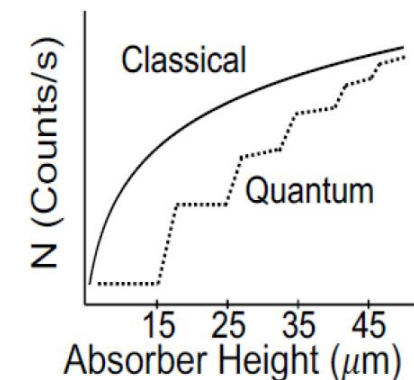
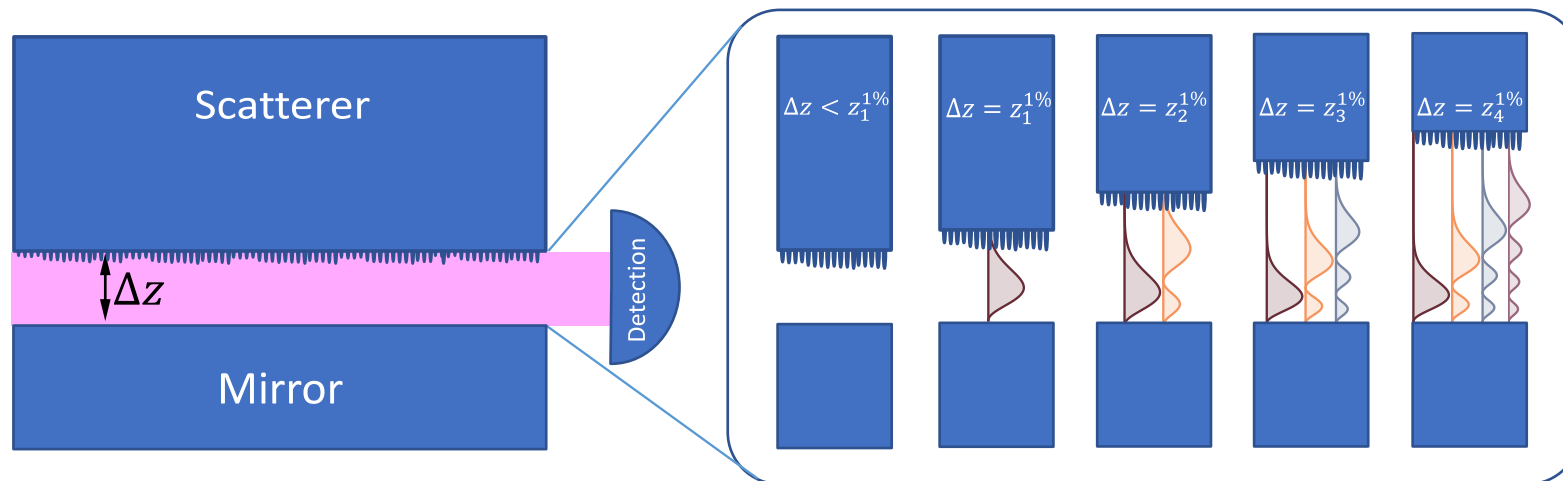

Quantum Reflection (QR)

- Purely quantum mechanical phenomenon
- Reflection from attractive Casimir-Polder potential far from surface (~ 100 nm)
- Potential modelled with $V_4 = -C_4/r^4$
- Reflection probability $R \approx \exp(-4mv\sqrt{2mC_4}/\hbar^2)$ depends on:
 - Atom mass, polarizability and incident velocity
 - Surfaces relative permittivity, conductivity / dielectric properties
- Calculations involving exact potentials only available for anti-hydrogen [2]

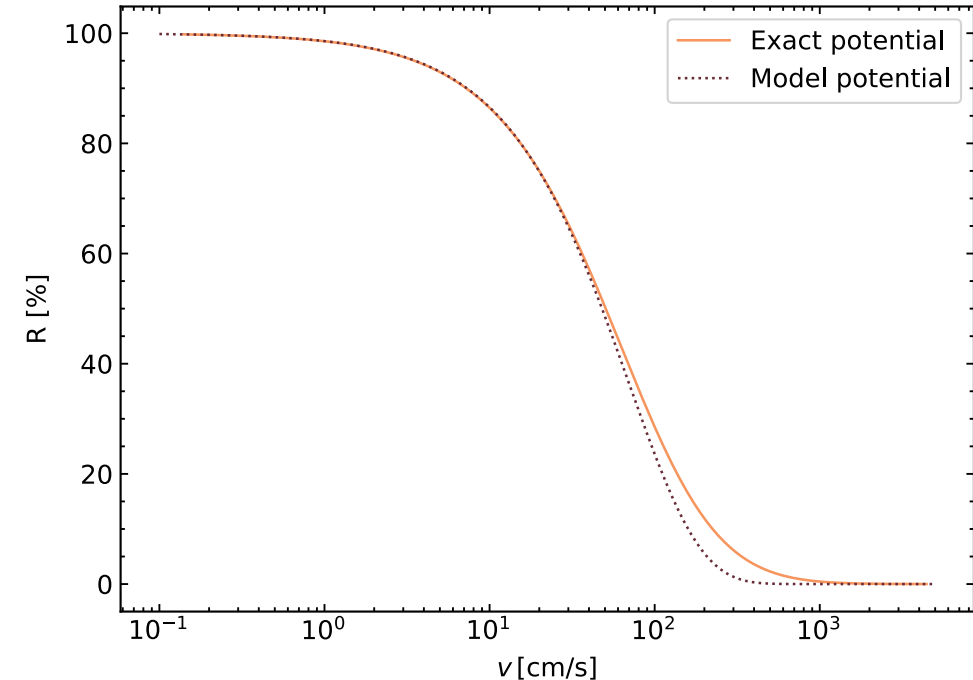

QR for (anti-) H above silicon calculated from model potential and exact potential [2].

Quantum Reflection (QR)

- Observed for H atoms over liquid He-surface [3]
- Observed for heavier atoms above solid surfaces [4-6]
- H above silicon (Si) surface:
 - Never measured before!
 - Higher QR probabilities expected than for heavier atoms!
 - QR probability $> 90\%$ for $v_{\perp} < 7$ cm/s above Si surface [2]

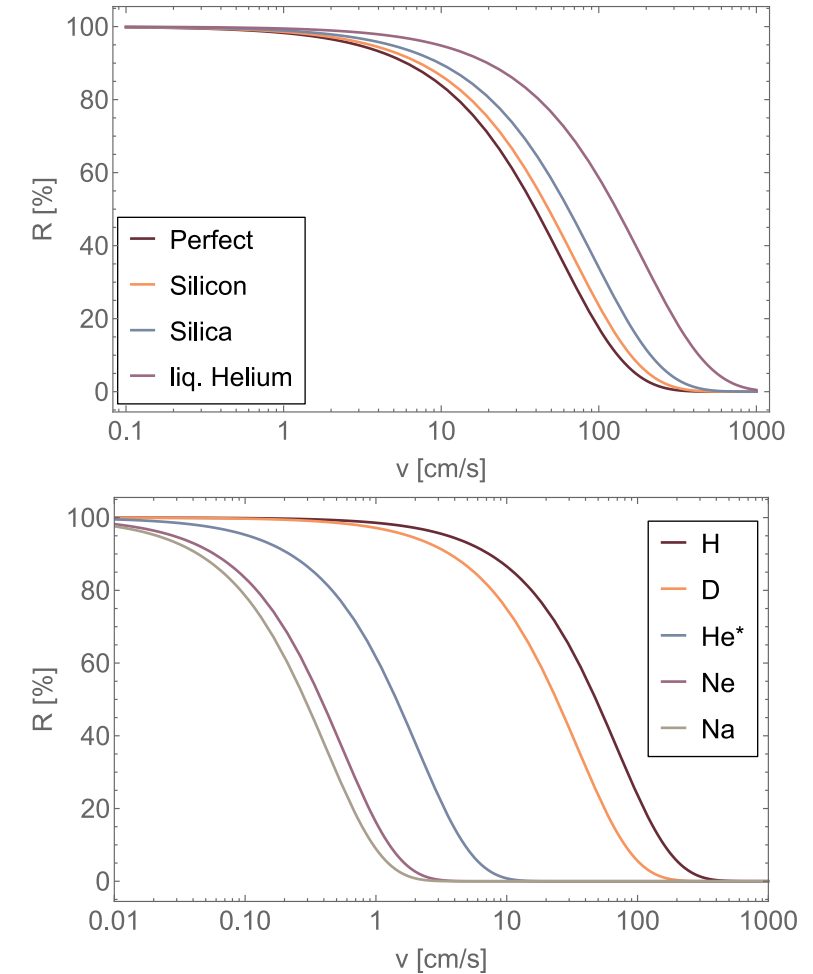

Quantum reflection probability R (calculated from model potential) as a function of the incident velocity for hydrogen above different surfaces (top) and different atoms above silicon (bottom).

Motivation

- QR of H above solid surfaces opens prospects for
 - Precision studies of atom-surface interactions
 - GQS measurements of H (and antihydrogen!)
 - Other measurements involving reflection (e.g. whispering gallery, next talk by Valery Nesvizhevsky)
- GQS are sensitive to hypothetical short-range forces
- First GQS measurements with atoms
- Tabletop alternative to reactor-based neutron GQS experiments
- Better statistics than with neutrons

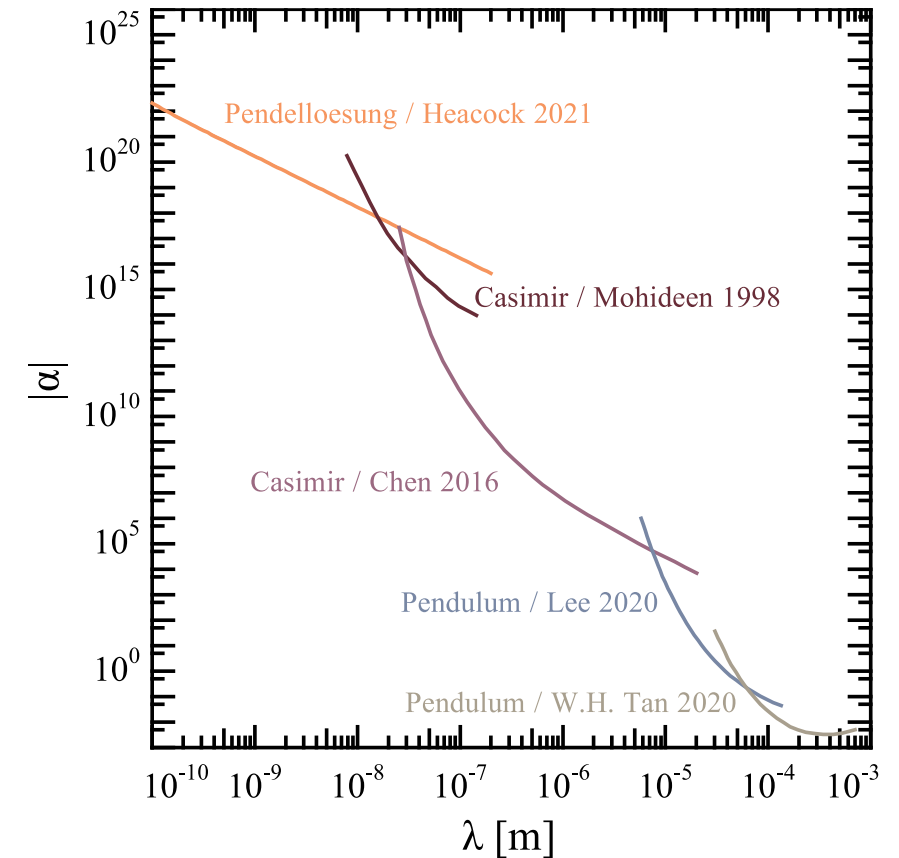

Constrains for new spin-independent short-range forces [7].

Hydrogen beam - experimental setup

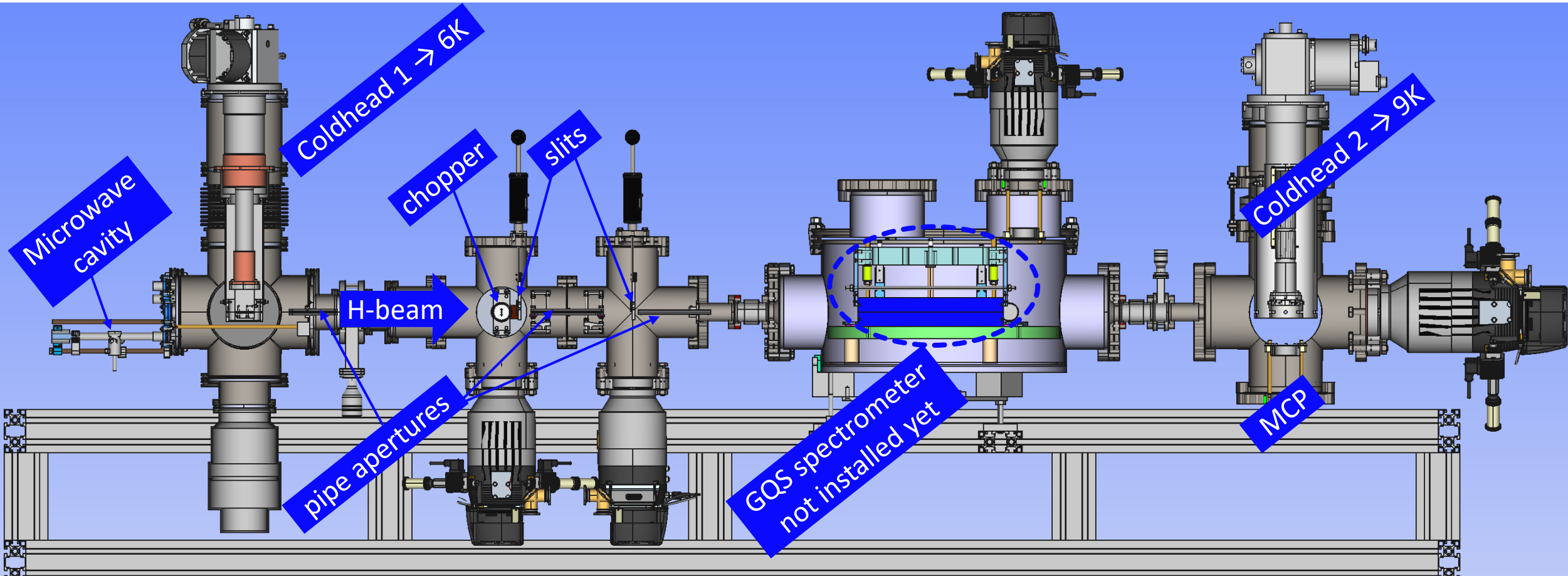

Hydrogen beam – experimental setup

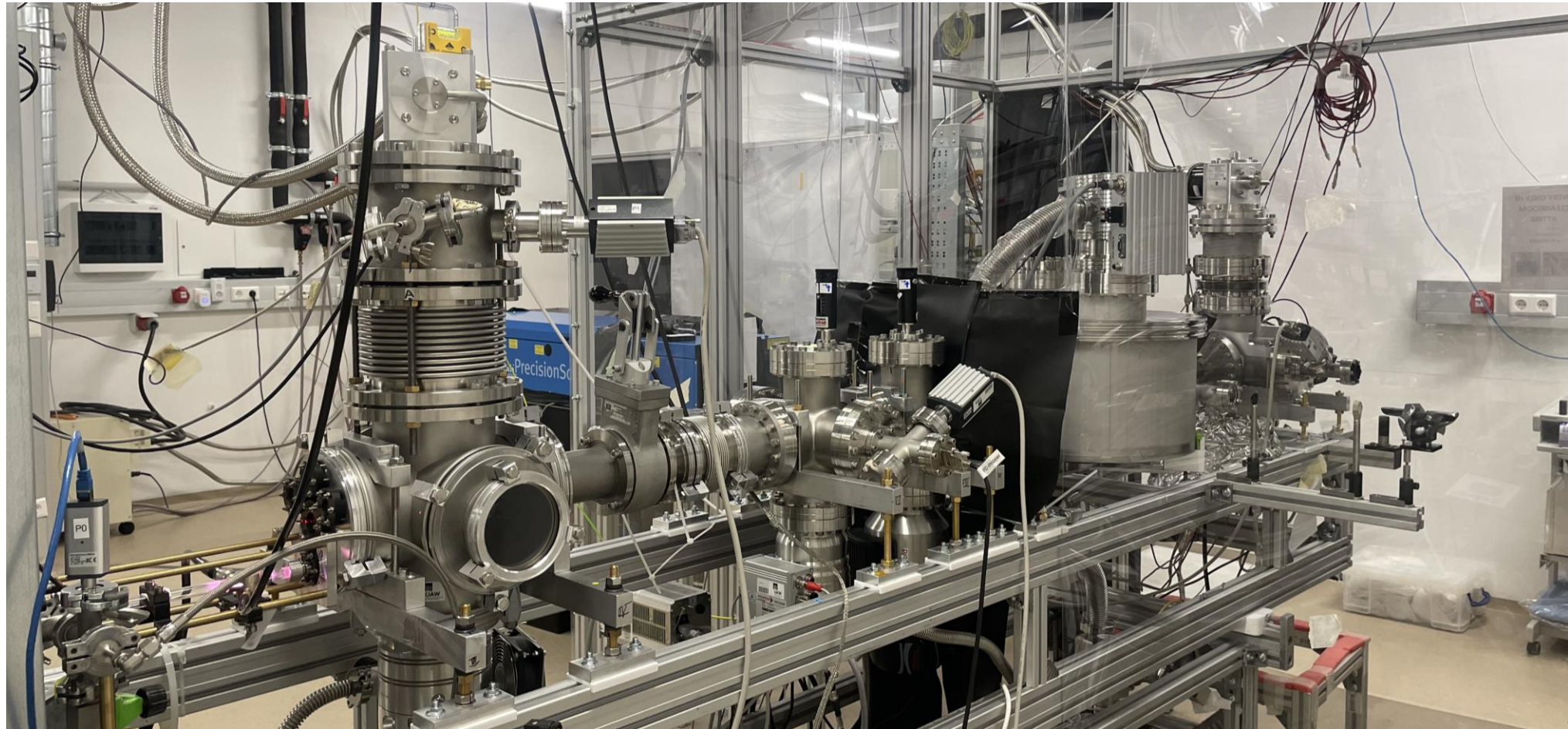

Requirements for a GQS measurement

Requirements for a GQS measurement

1. Efficient detection of hydrogen

Requirements for a GQS measurement

1. Efficient detection of hydrogen

- Ionization of H with a pulsed UV-Laser ($\lambda = 243 \text{ nm}$)
 - 2 photon excitation ($1s-2s$) + 1 photon ionization
 - Laser system described in [8]

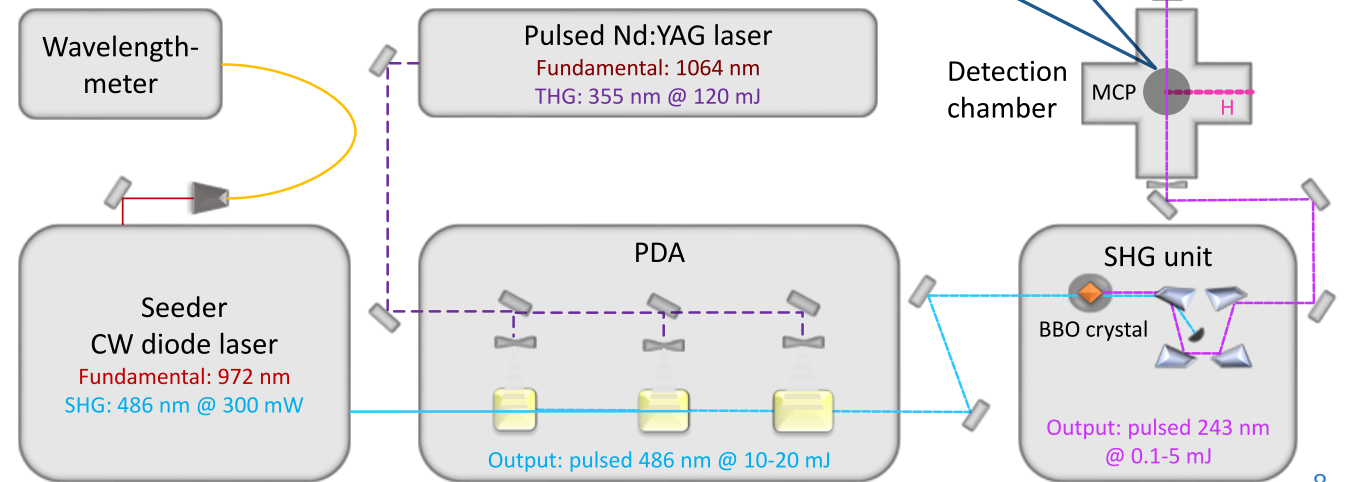
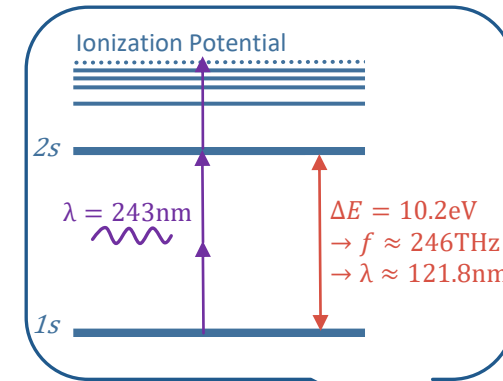

[8] Killian, C. et al. Eur. Phys. J. D 77, 50 (2023).
<https://doi.org/10.1140/epjd/s10053-023-00634-4>

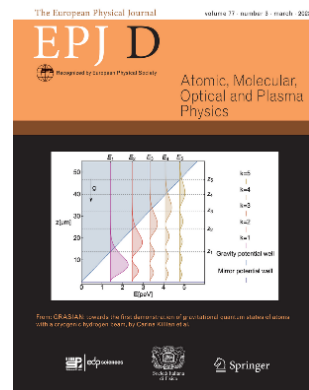

Requirements for a GQS measurement

1. Efficient detection of hydrogen

- Focusing of UV beam

→ Very high photon density

→ Ionization efficiency ε up to $\approx 100\%$

- Detection of H^+ with a microchannel plate
- Integrated MCP-Signal $\propto H^-$ count rate

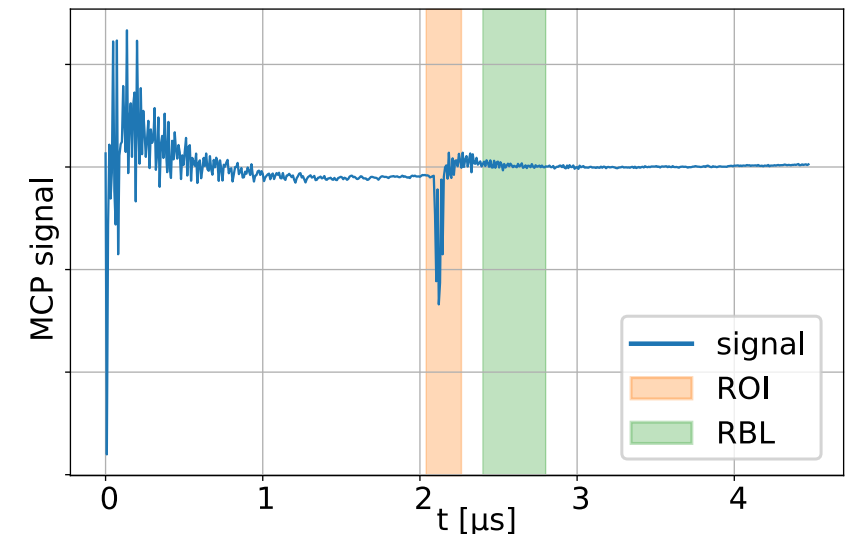
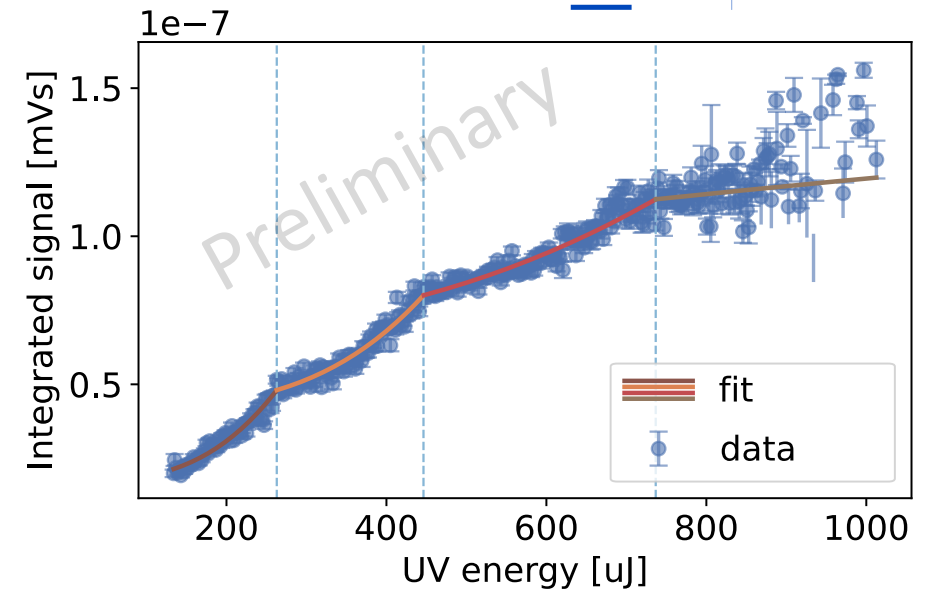

Requirements for a GQS measurement

1. Efficient detection of hydrogen ✓
2. Low background

Requirements for a GQS measurement

1. Efficient detection of hydrogen ✓
2. Low background
 - 9K Heatshield around ionization area
 - BG reduced by > 1 order of magnitude

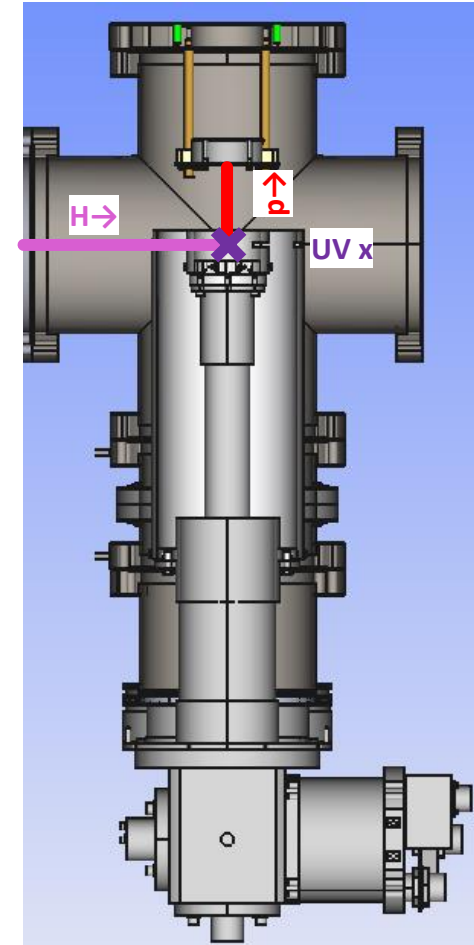
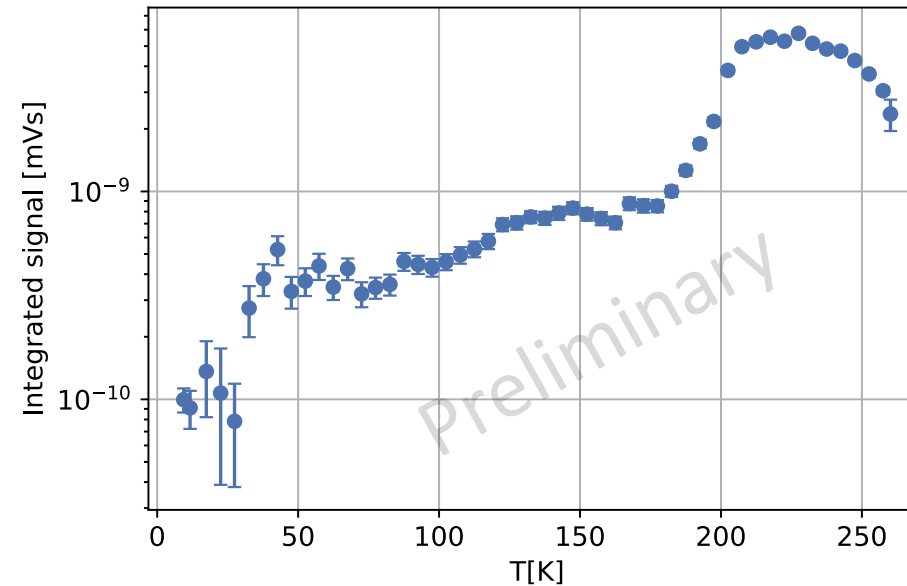

Requirements for a GQS measurement

1. Efficient detection of hydrogen ✓
2. Low background ✓
3. Low horizontal velocities

Requirements for a GQS measurement

1. Efficient detection of hydrogen ✓
2. Low background ✓
3. Low horizontal velocities
 - Interaction time $\gg 1\text{ms} \rightarrow v_x \approx 100\text{ m/s}$
 - Time of flight (ToF) measurements
 - Slowest resolvable velocity $v_x \in [58, 72]\text{ m/s}$

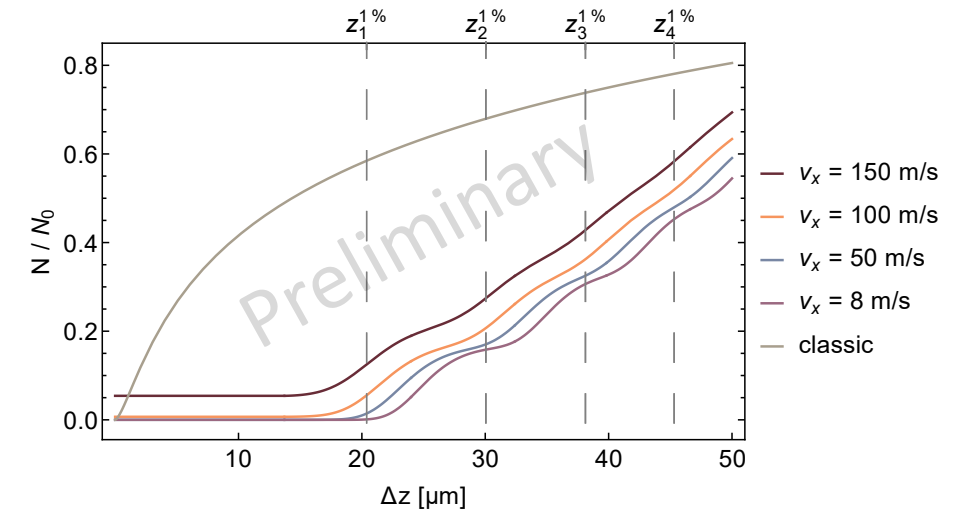
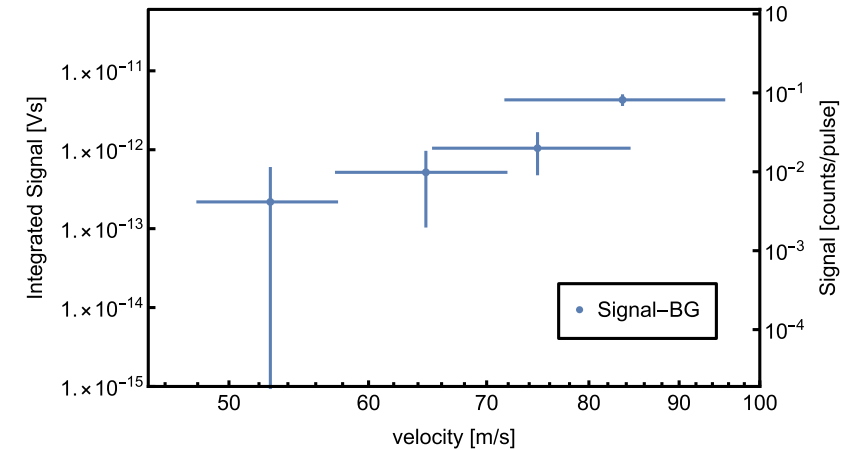

Requirements for a GQS measurement

1. Efficient detection of hydrogen ✓
2. Low background ✓
3. Low horizontal velocities ✓
4. Very low vertical velocity components

Requirements for a GQS measurement

1. Efficient detection of hydrogen ✓
2. Low background ✓
3. Low horizontal velocities ✓
4. Very low vertical velocity components
 - Quantum reflection probability $> 90\%$ for $|v_z| < 7$ cm/s [2]
 - Trajectory simulations confirm vertical velocities on the order of 10 cm/s

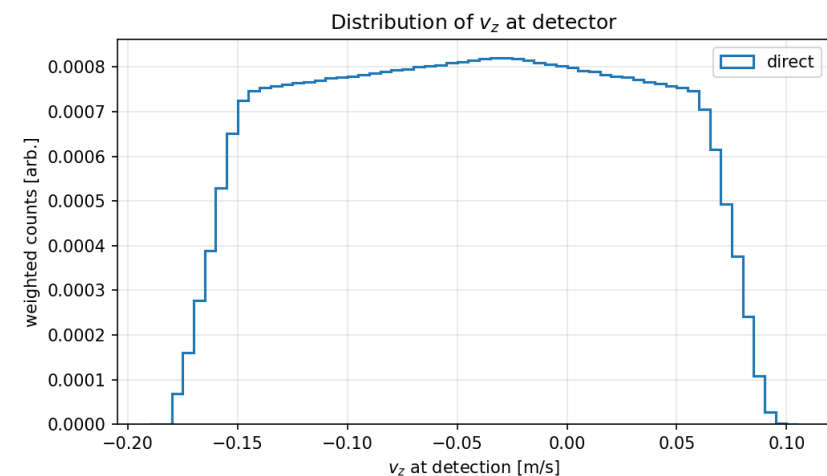
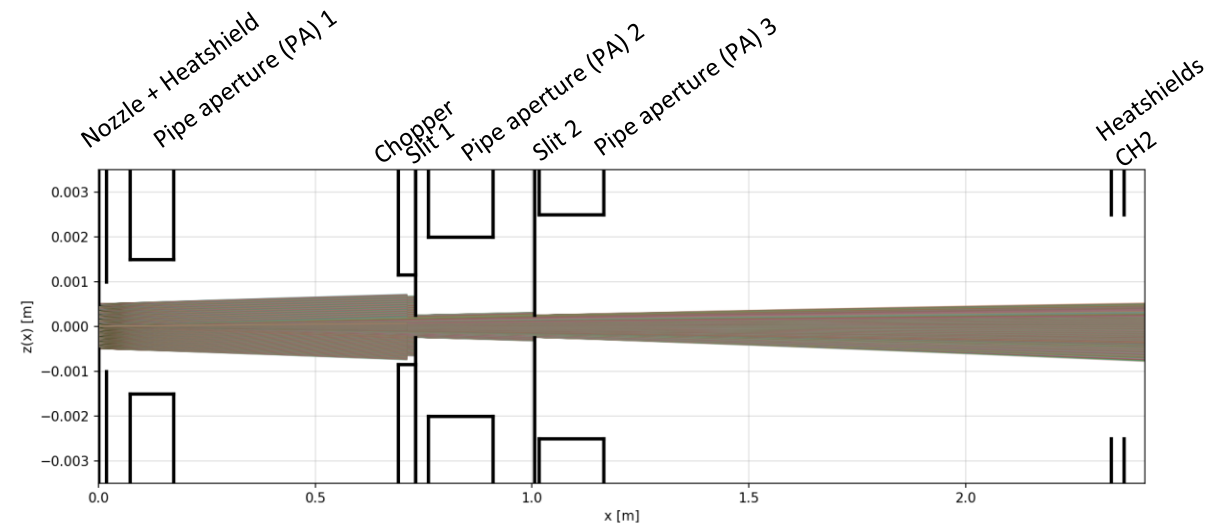

Requirements for GQS measurement

1. Efficient detection of hydrogen ✓
2. Low background ✓
3. Low horizontal velocities ✓
4. Very low vertical velocity components
(only simulations) ✓

→ Requirements fulfilled

→ Next step: installation of GQS spectrometer

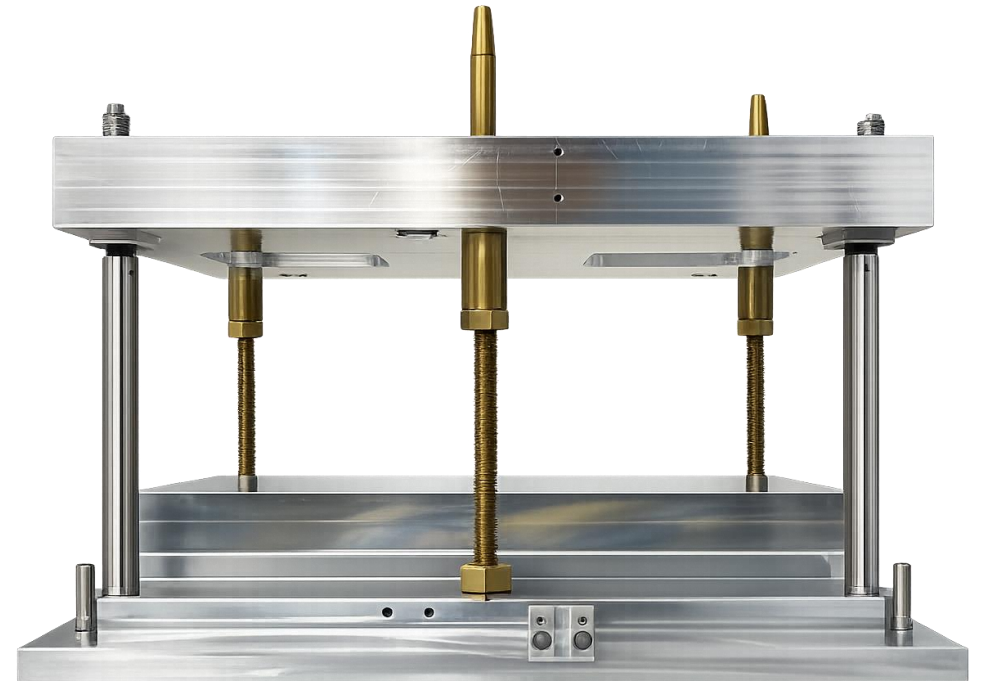

Installation of GQS spectrometer

Silicon Mirror + Absorber separated by 200 μm spacers were inserted

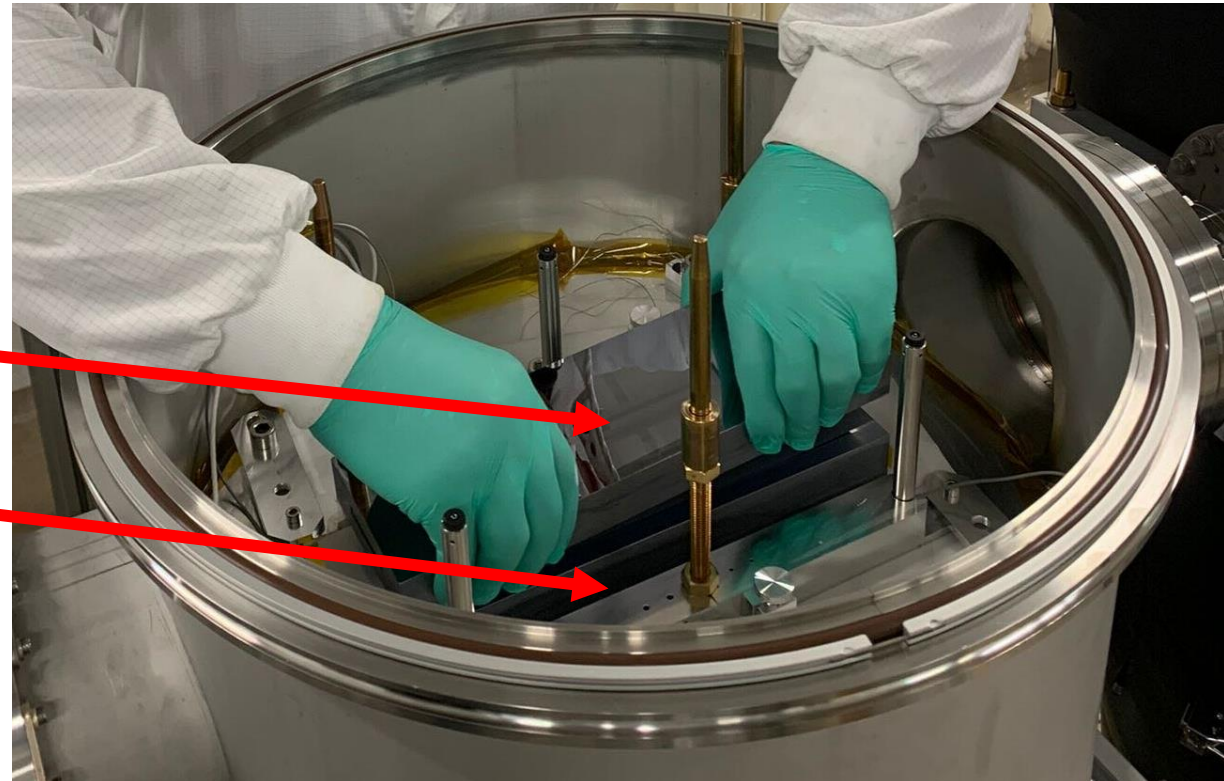
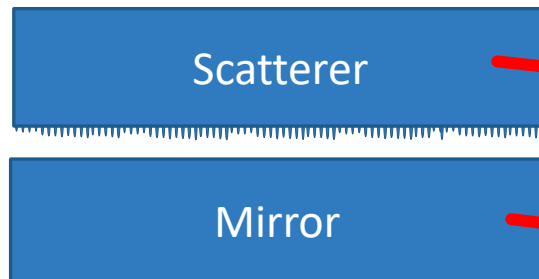

First measurements with 200 μm mirror-absorber separation

Recorded vertical profiles for different ToF (horizontal velocity v_x)

A second peak appears above the beam axis for lower v_x

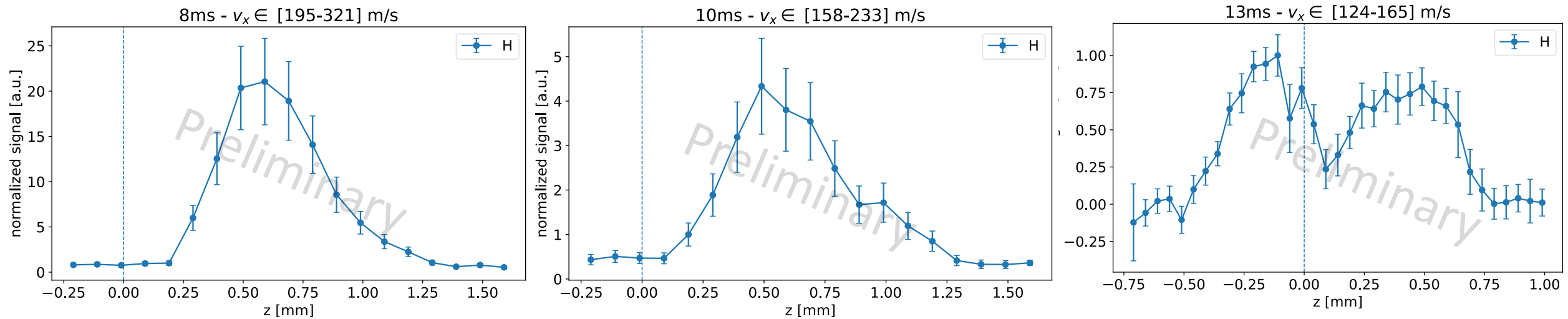

First measurements with 200 μm mirror-absorber separation

Recorded vertical profiles for different ToF (horizontal velocity v_x)

A second peak appears above the beam axis for lower v_x

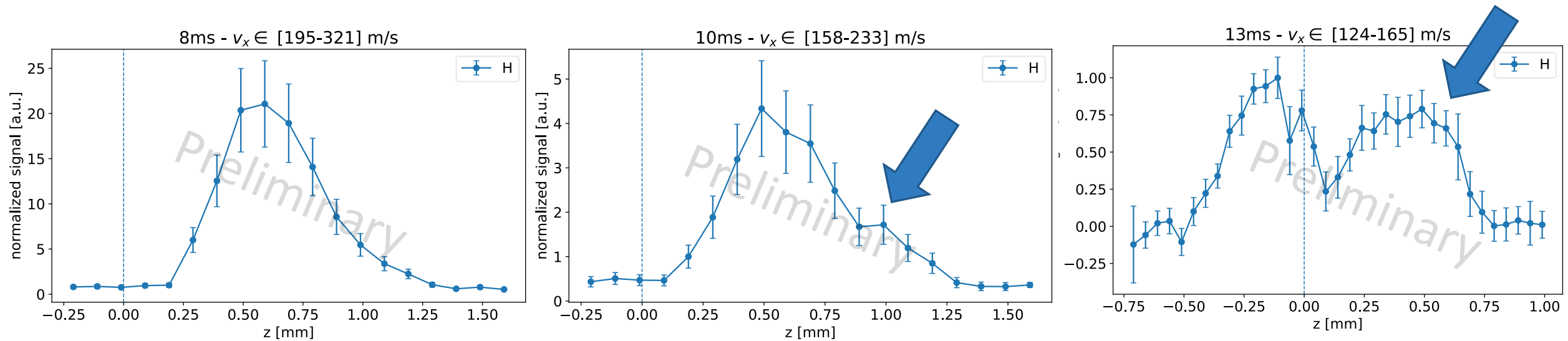

First indication of quantum reflection of H above a Silicon surface

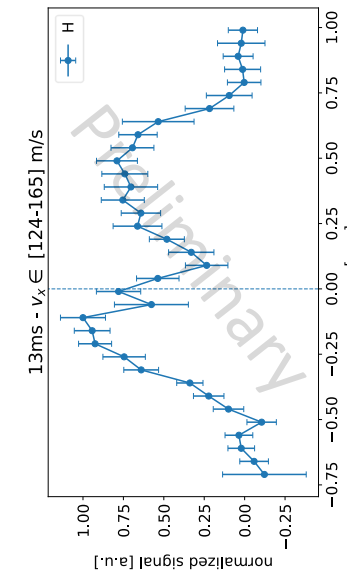
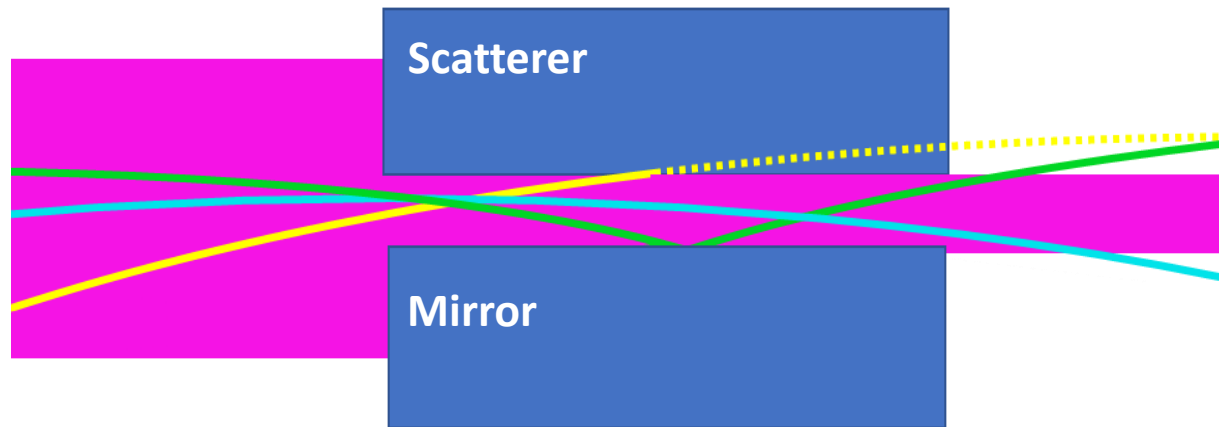

Trajectories leading to 2nd peak only possible if bounce (reflection) occurs

Slower v_x : stronger curvature of trajectories \rightarrow higher incident velocity

Trajectory simulations confirm / predict the shapes of the vertical profiles

QR – Measurement campaign 2026

- QR of H above solid surface never observed before
- Measurements of vertical profiles for different horizontal velocities v_x (ToF) and mirror angles Θ (→ higher incident velocity)
- Additional measurements with deuterium
→ measurement of isotopic shift
- Data taking finished last week

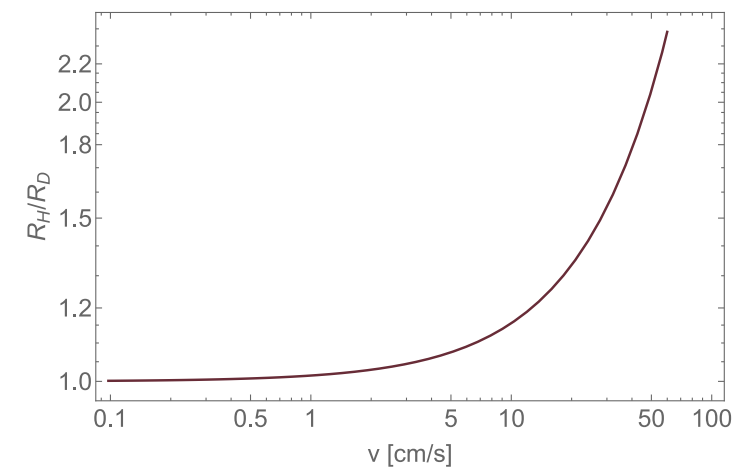
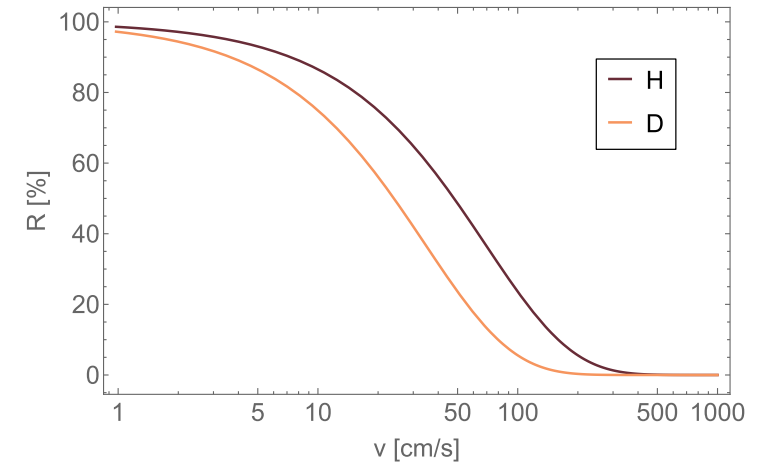

QR – Measurement campaign 2026

- QR of H above solid surface never observed before
- Measurements of vertical profiles for different horizontal velocities v_x (ToF) and mirror angles Θ (→ higher incident velocity)
- Additional measurements with deuterium
→ measurement of isotopic shift
- Data taking finished last week

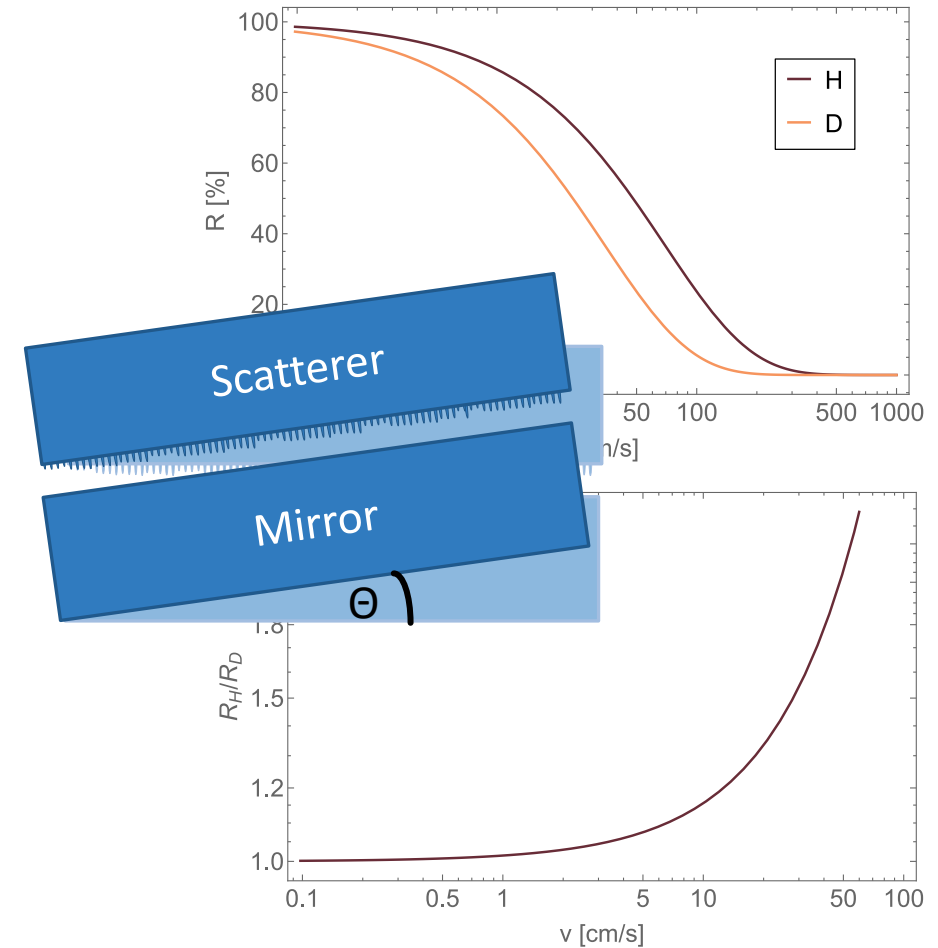

QR – Measurement campaign 2026

- QR of H above solid surface never observed before
- Measurements of vertical profiles for different horizontal velocities v_x (ToF) and mirror angles Θ (→ higher incident velocity)
- Additional measurements with deuterium
→ measurement of isotopic shift
- Data taking finished last week

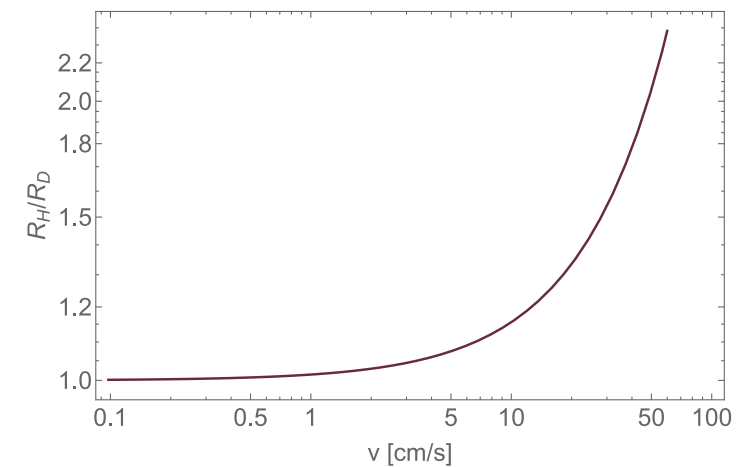
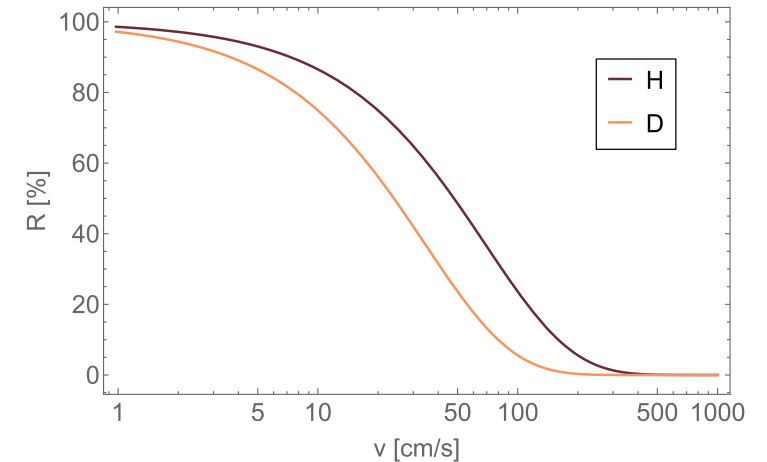

QR – Measurement campaign 2026 Hydrogen/ Deuterium

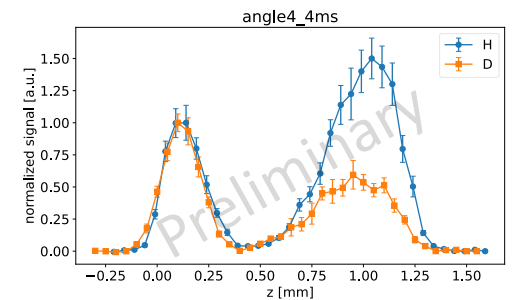
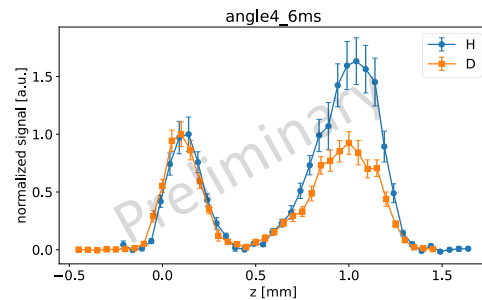
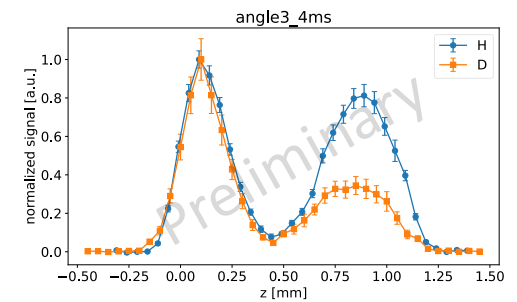
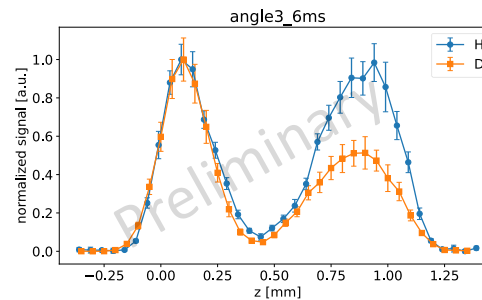
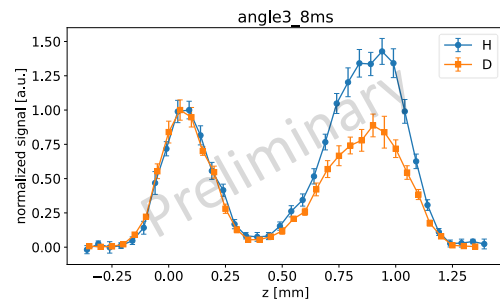
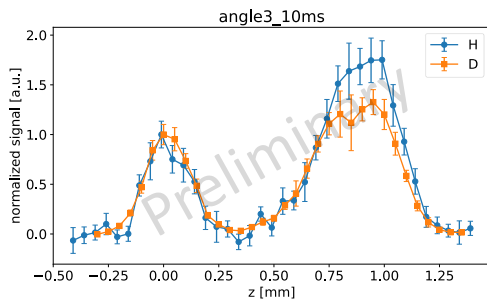
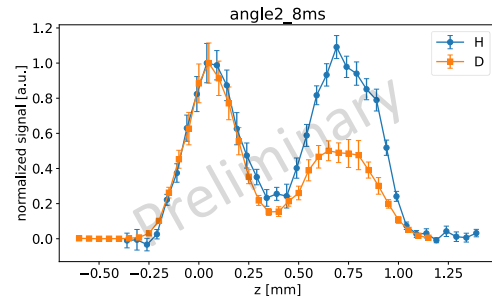
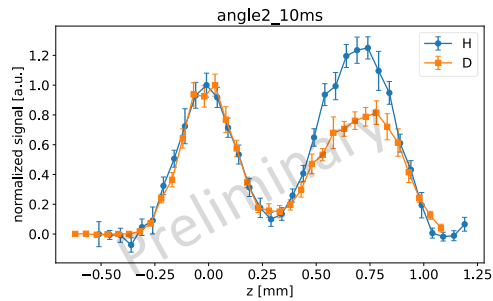
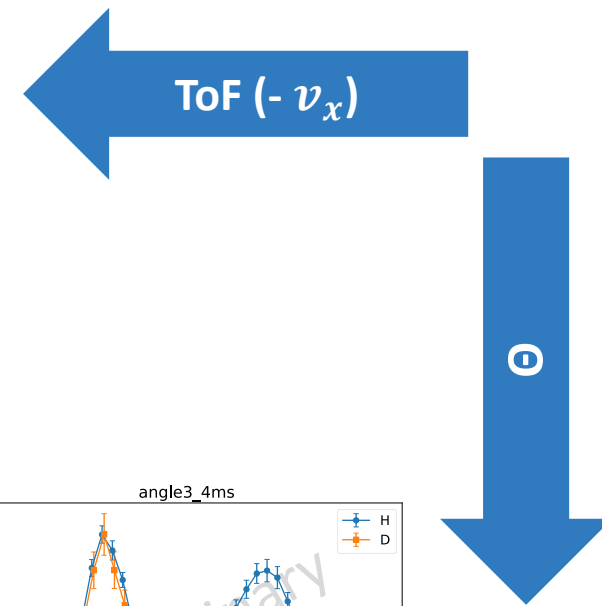

QR – Measurement campaign 2026 Hydrogen/ Deuterium

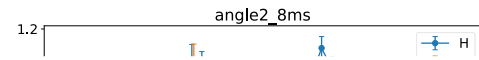
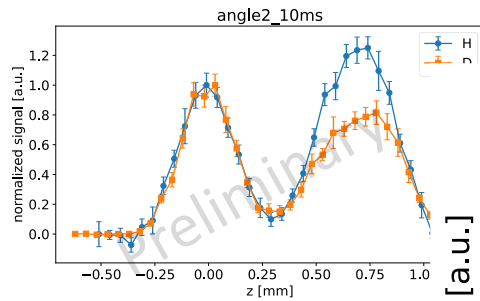
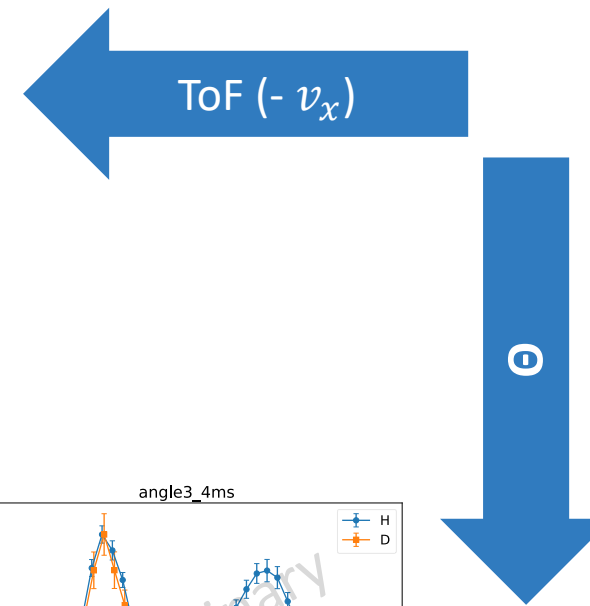

angle3_8ms

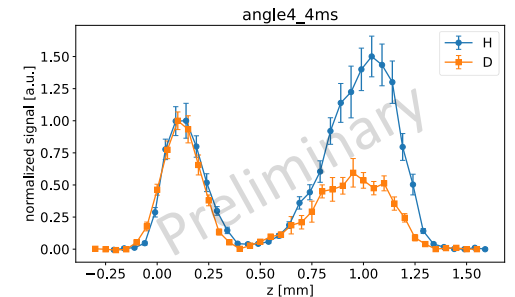
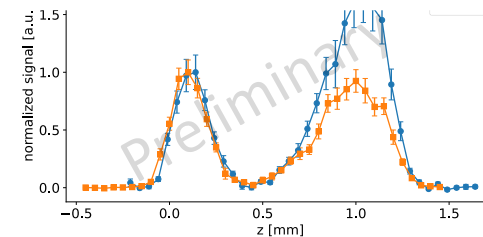
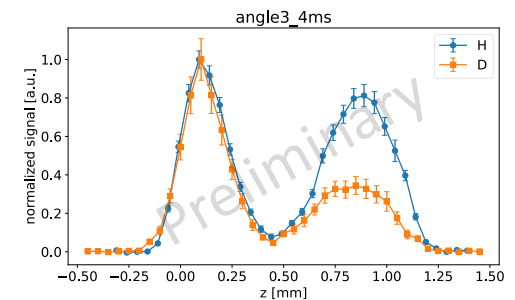
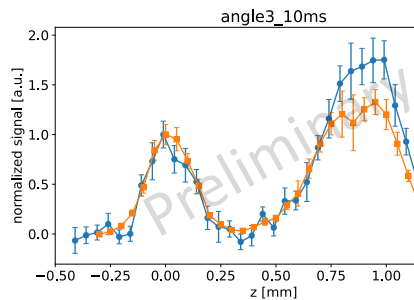
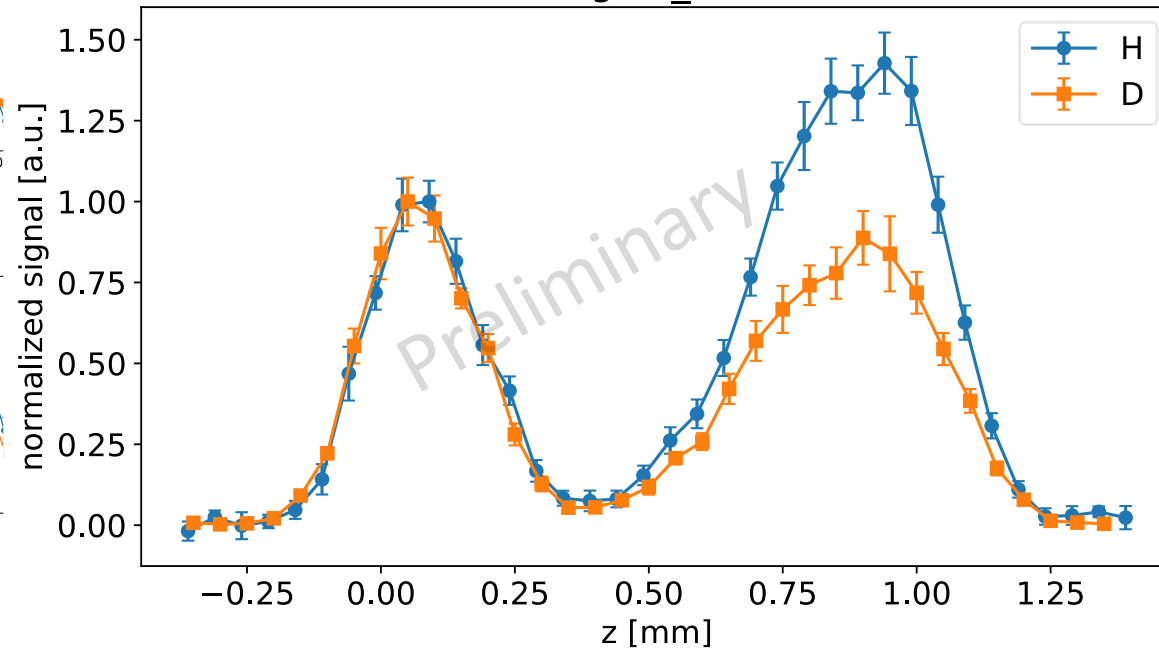

QR Analysis

- Extensive analysis still in progress → Preliminary results
- Trajectory simulations
- Reflection from mirror: $v_{\perp}(x) \rightarrow -v_{\perp}(x)$
- Reflection probability fitted

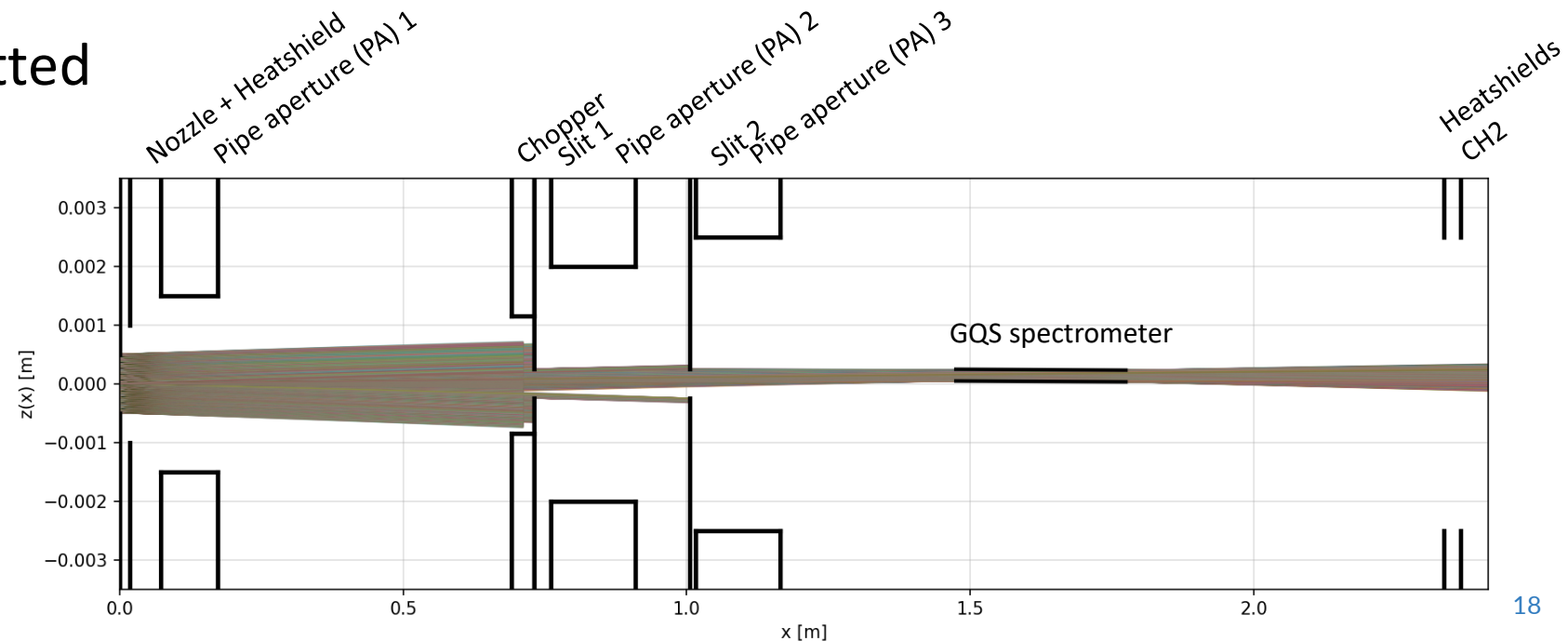
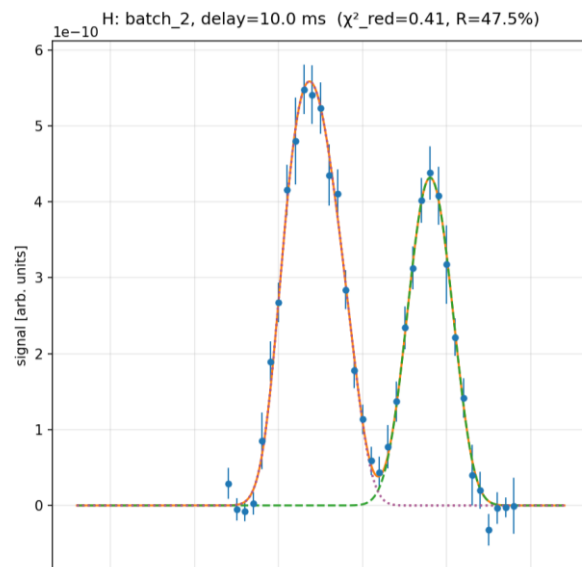

QR preliminary results

Hydrogen

R vs $|v_{\perp}|$ (from fitted bins)

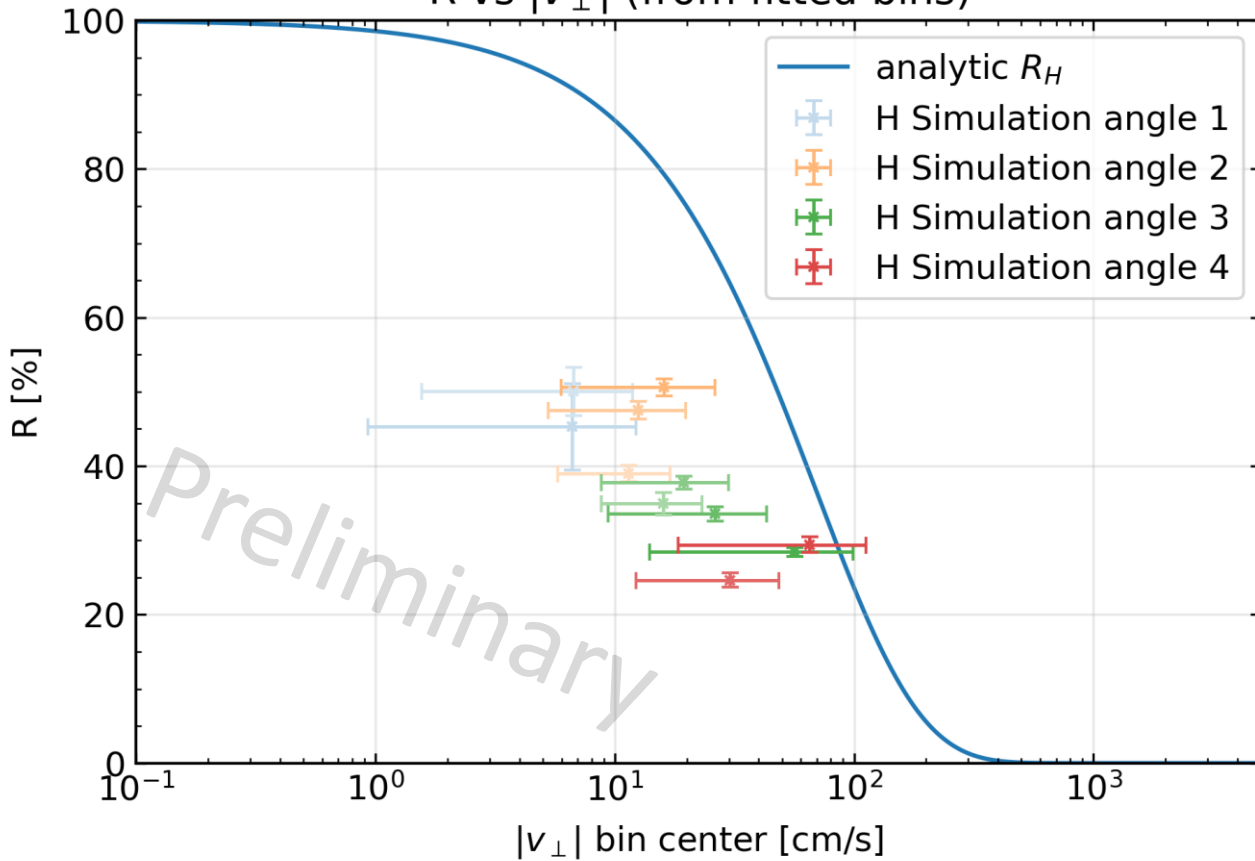

Deuterium

R vs $|v_{\perp}|$ (from fitted bins)

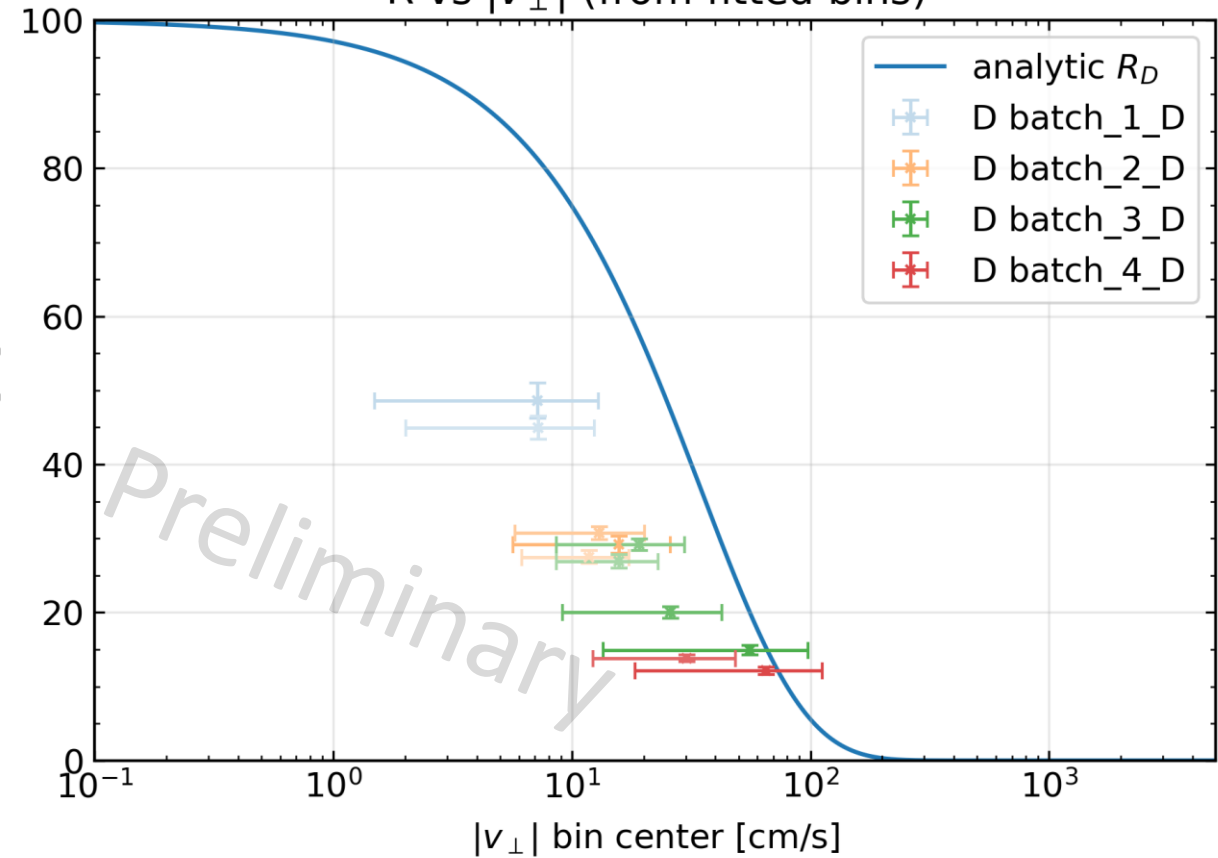

QR preliminary results – isotope ratio

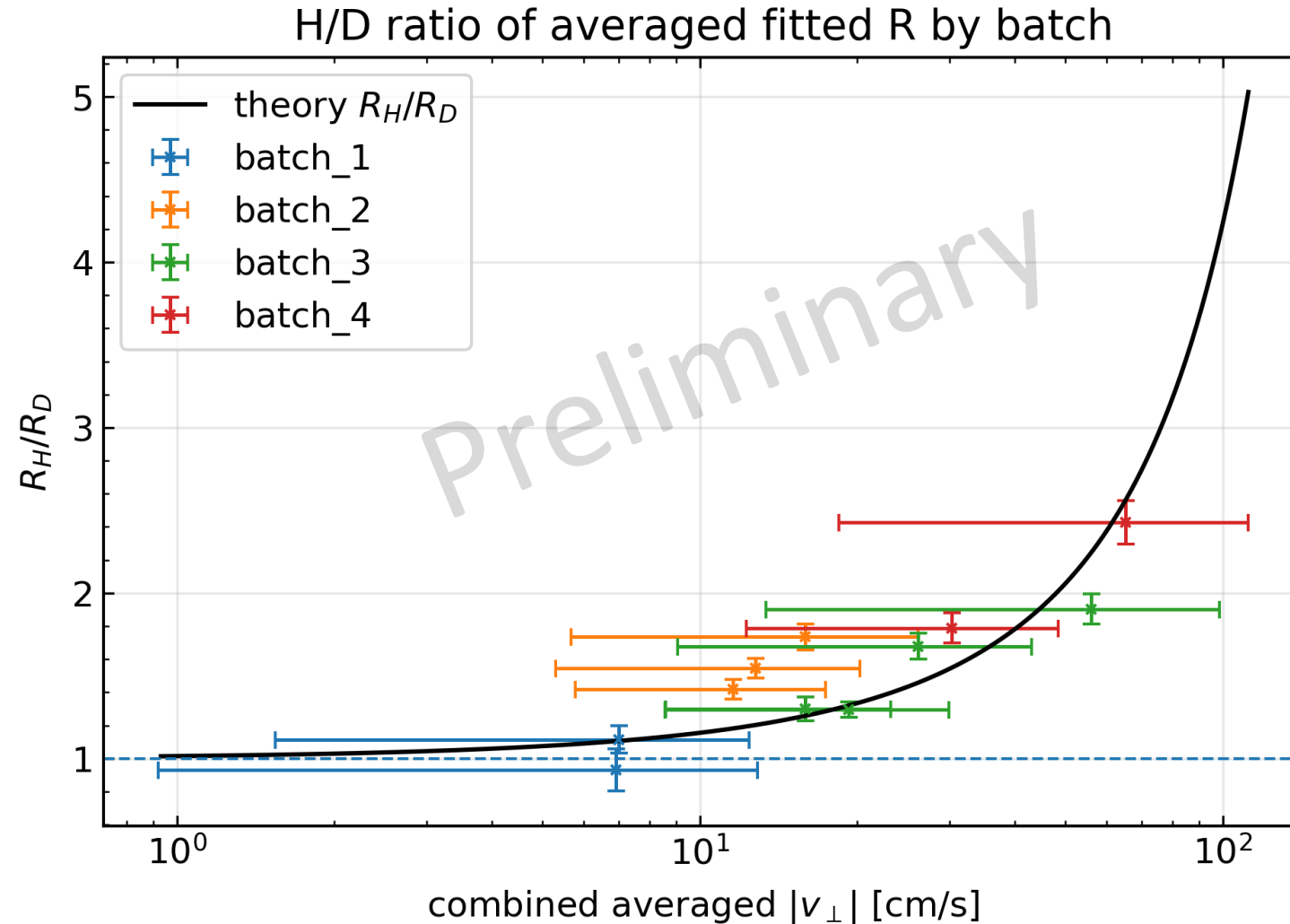

QR preliminary results

- Fitted reflection probabilities lower than expected
- Possible explanation: surface layer build ups / impurities ... ?
- But: QR with > 50% observed!
 - Enough for GQS measurement
- Trend is clearly observed: $R \rightarrow 1$ for lower incident velocities
- Outlook:
 - Dilution fridge ready in 2027 - 100 mK H-beam
 - Zeeman deceleration (Poster Elio Bera)

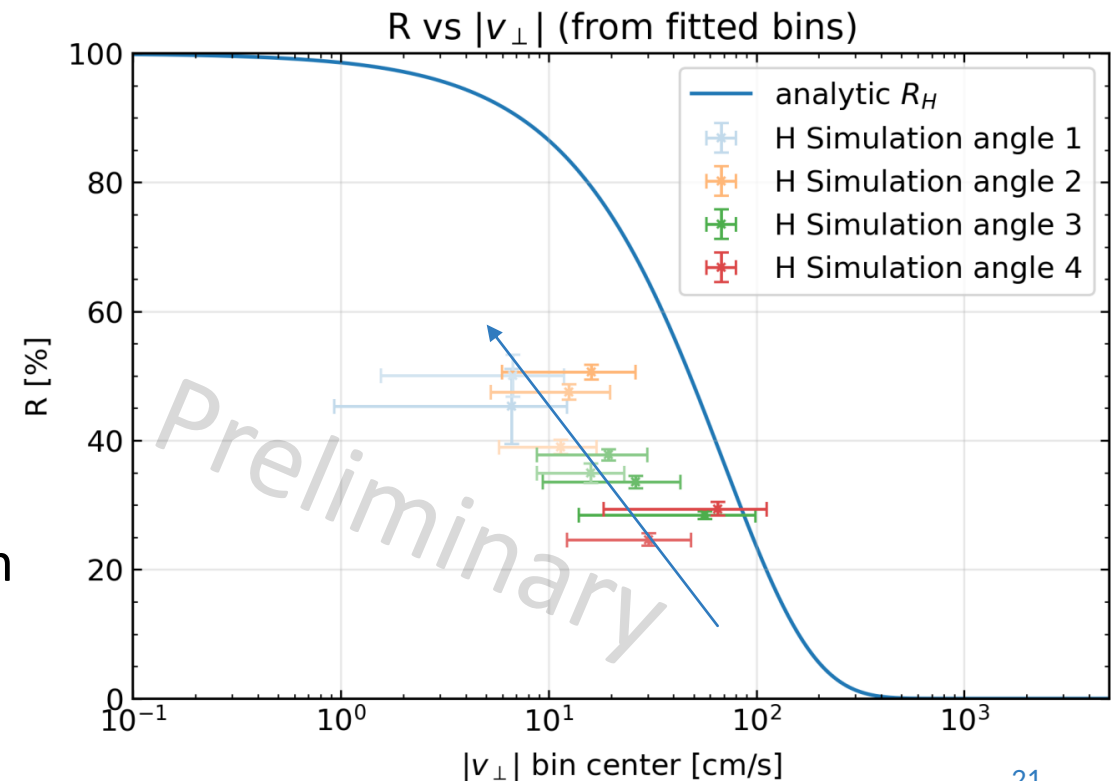

Summary and Outlook

- Requirements for GQS measurement fulfilled ✓
- GQS spectrometer installed ✓
- Measurements with 200 μm separation
- **First observation of QR of H and D above Si surface!** ✓

Outlook:

- GQS measurements starting next week
- Stay tuned 😊



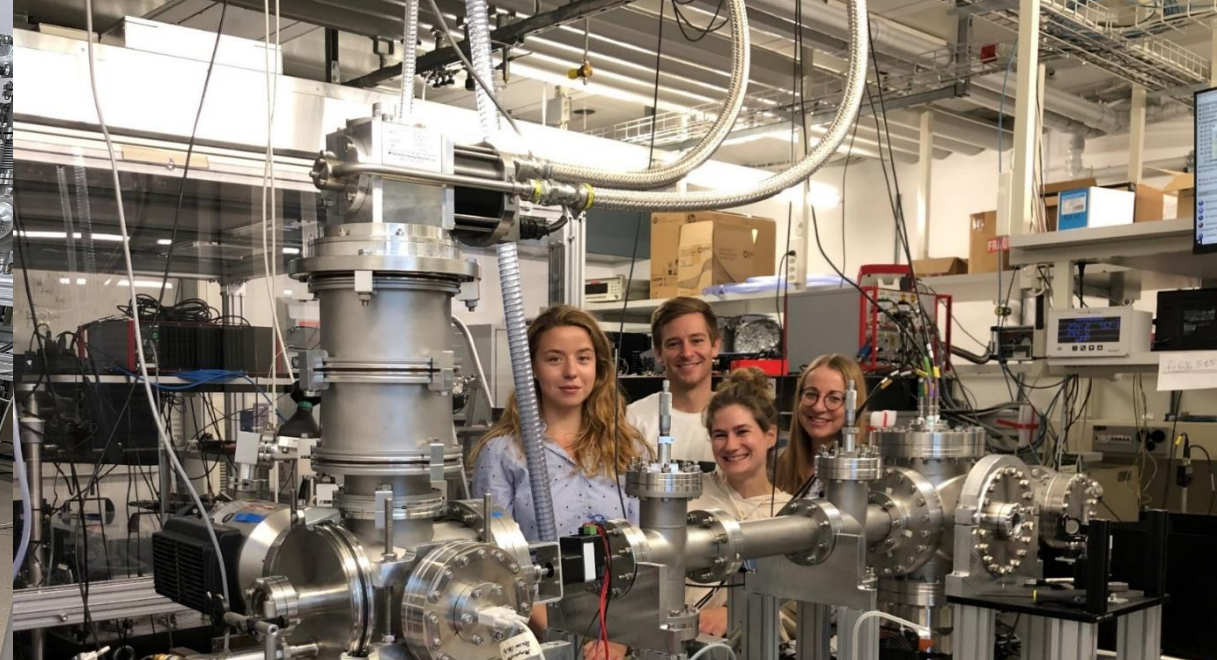

Thank you for your attention!

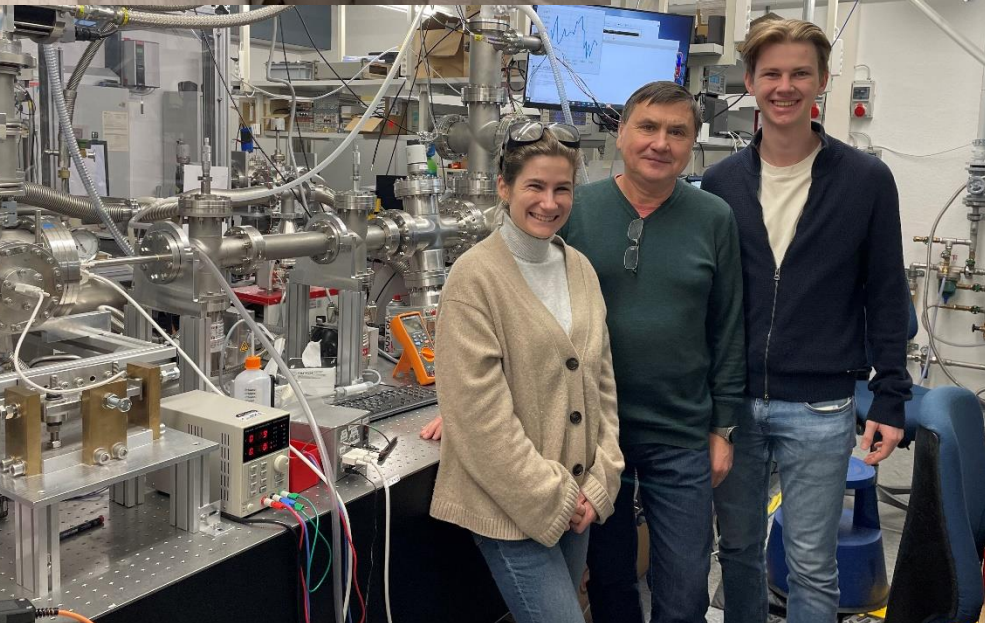

References

- [1] V. Nesvizhevsky et al., Quantum states of neutrons in the Earth's gravitational field. *Nature* **415**, 297–299 (2002). <https://doi.org/10.1038/415297a>
- [2] Crépin, P.-P. and Kupriyanova *et al.* Quantum reflection of antihydrogen from a liquid helium film. *EPL* **119**, 1286-4854 (2017). <http://dx.doi.org/10.1209/0295-5075/119/33001>
- [3] Ite A. Yu et al. Evidence for universal quantum reflection of hydrogen from liquid 4He. *Physical Review Letters* <https://doi.org/10.1103/PhysRevLett.86.987>
- [4] Pasquini et al. “Quantum Reflection from a Solid Surface at Normal Incidence” *Physical Review Letters* 93.22 <https://doi.org/10.1103/PhysRevLett.93.223201>
- [5] V. Druzhinina and M. DeKieviet. “Experimental Observation of Quantum Reflection far from Threshold” *Physical Review Letters* 91.19 <https://doi.org/10.1103/PhysRevLett.91.193202>
- [6] Shimizu, Fujio. “Specular Reflection of Very Slow Metastable Neon Atoms from a Solid Surface.” *Physical Review Letters* 86
- [7] H. Abele et al. “Particle physics at the European Spallation Source”. *Physics Reports* 1023 (June 2023), pp. 1–84. issn: 03701573. doi: 10.1016/j.physrep.2023.06.001
- [8] Killian, C. et al. GRASIAN: towards the first demonstration of gravitational quantum states of atoms with a cryogenic hydrogen beam. *Eur. Phys. J. D* 77, 50 (2023). <https://doi.org/10.1140/epjd/s10053-023-00634-4>
- [9] Killian, C et al. GRASIAN: shaping and characterization of the cold hydrogen and deuterium beams for the forthcoming first demonstration of gravitational quantum states of atoms. *Eur. Phys. J. D* 78, 132 (2024). <https://doi.org/10.1140/epjd/s10053-024-00916-5>