

# Probing bound-state QED above the Schwinger limit with high precision kaonic atoms measurements



Istituto Nazionale di Fisica Nucleare  
Laboratori Nazionali di Frascati

**FRANCESCO CLOZZA** on behalf of the *SIDDHARTA-2* collaboration  
International Conference on Precision Physics of Simple Atomic Systems



# Physics of Kaonic Atoms

## On the Disintegration of Negative Mesons

M. CONVERSI, E. PANCINI, AND O. PICCIONI\*

Centro di Fisica Nucleare del C. N. R. Istituto di  
Fisica dell'Università di Roma, Italia

December 21, 1946

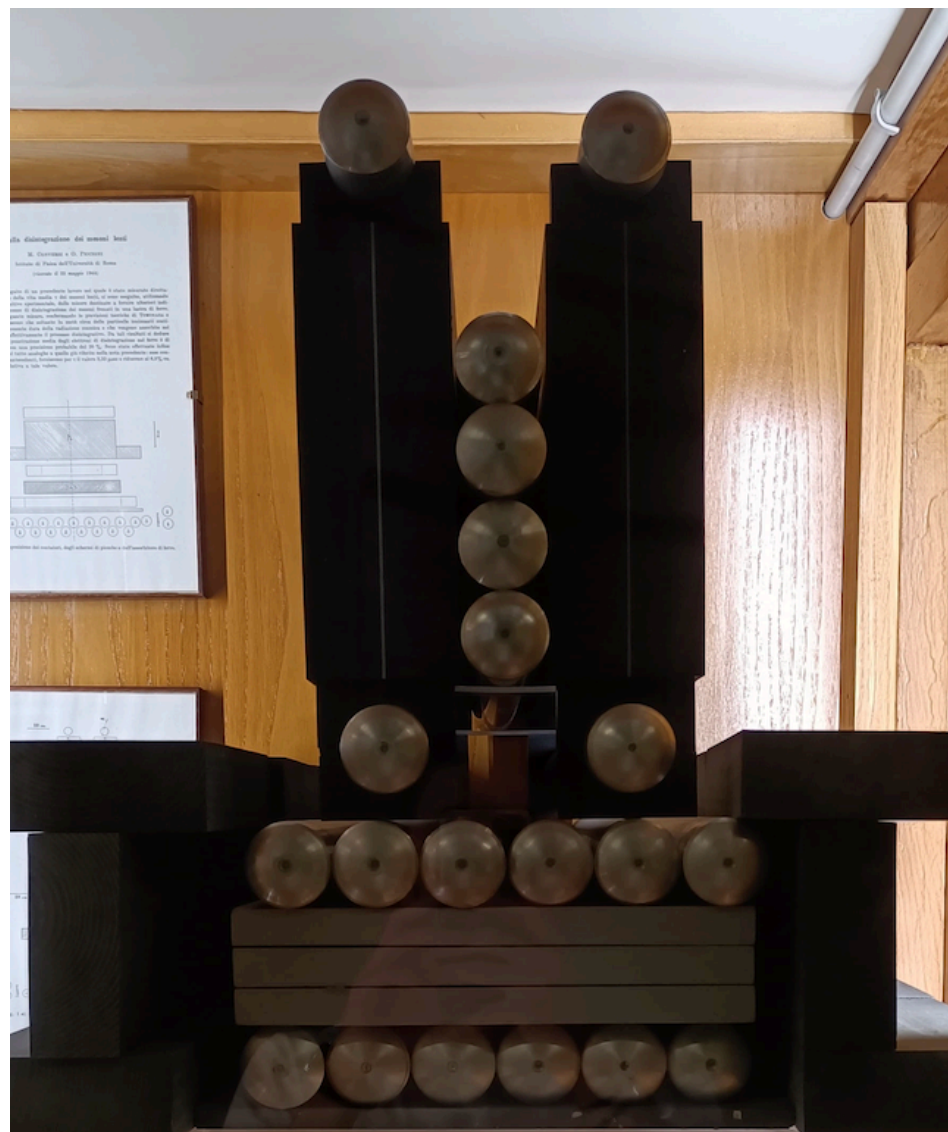

- Predicted in the '40s (Tomonaga and Araki, 1940; Conversi, Pancini, and Piccioni 1945, 1947)
- **Exotic Atoms**: atoms in which a negatively charged particle replaces an electron in the atomic orbit
- Study of hadronic atoms to probe the interaction between the hadron and the nucleus
- **Kaonic atoms** offer a unique way of directly probing the **low-energy strong interaction** and **bound-state QED** in atomic systems with **strangeness** [*Part. Nucl. Phys.* 147, 104226 (2026)]

# Physics of Kaonic Atoms

- $K^-$  slowed down and stopped inside a target
- Atomic capture followed by cascade process
- $K^-$  captured in an highly excited state  $n$
- Emission of radiation following the de-excitation

$$n \sim \sqrt{\frac{\mu}{m_e}} n_e$$

$$n \sim 28 \text{ K-}^4\text{He \& K-D}$$

$$n \sim 25 \text{ K-H}$$

$\mu$  system's reduced mass

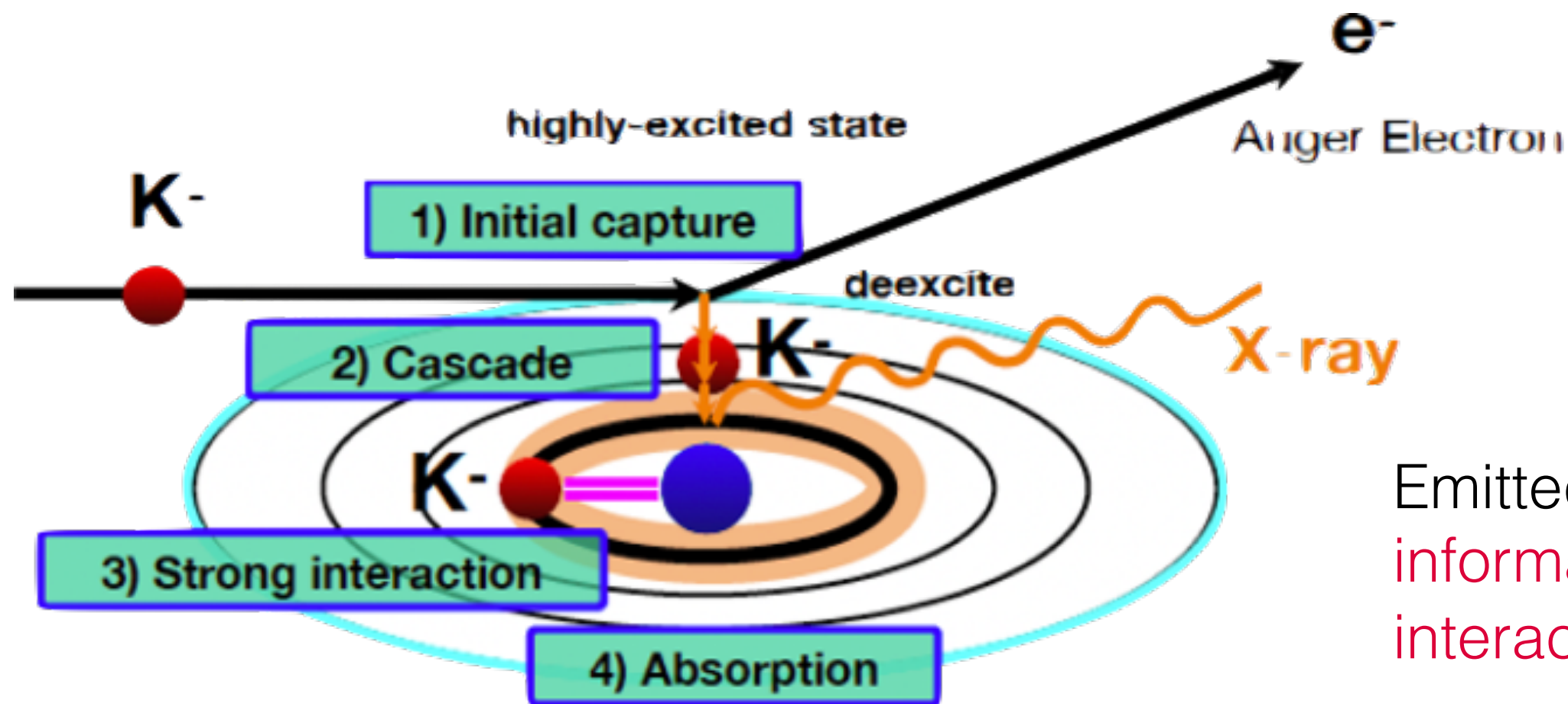

Emitted X-rays carry information on the  $K^-N$  interaction

# Hadronic researches with Kaonic Atoms

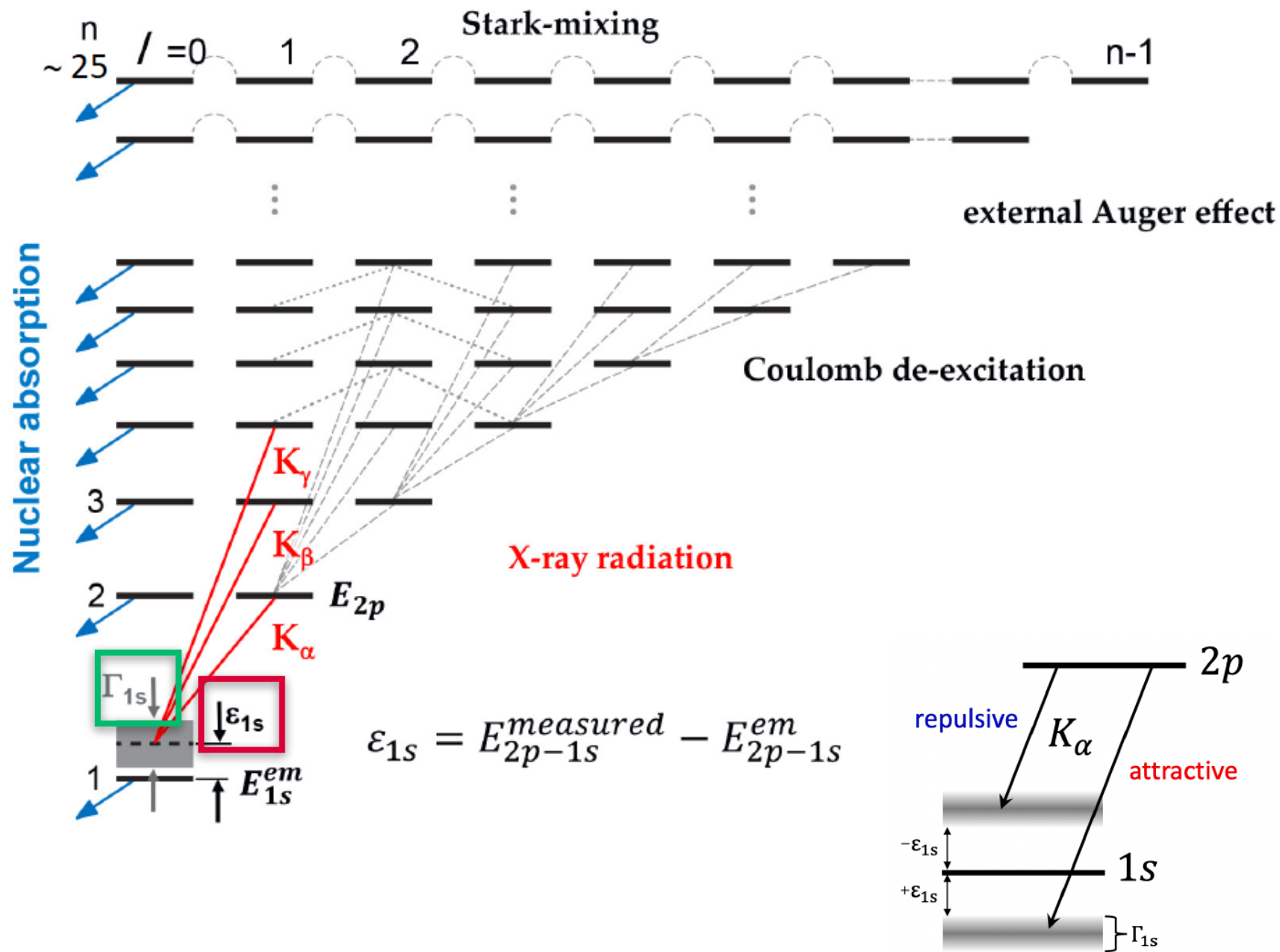

- Detected **X-Rays** carry information about the (strong) interaction
- Broadening ( $\Gamma$ ) and shift ( $\epsilon$ ) of the energy level induced by the strong interaction
- **Scientific goal:** performing the first measurement of kaonic deuterium X-ray transition to the fundamental level to extract  $\epsilon_{1s}$  and  $\Gamma_{1s}$

# The DAΦNE Collider of INFN-LNF

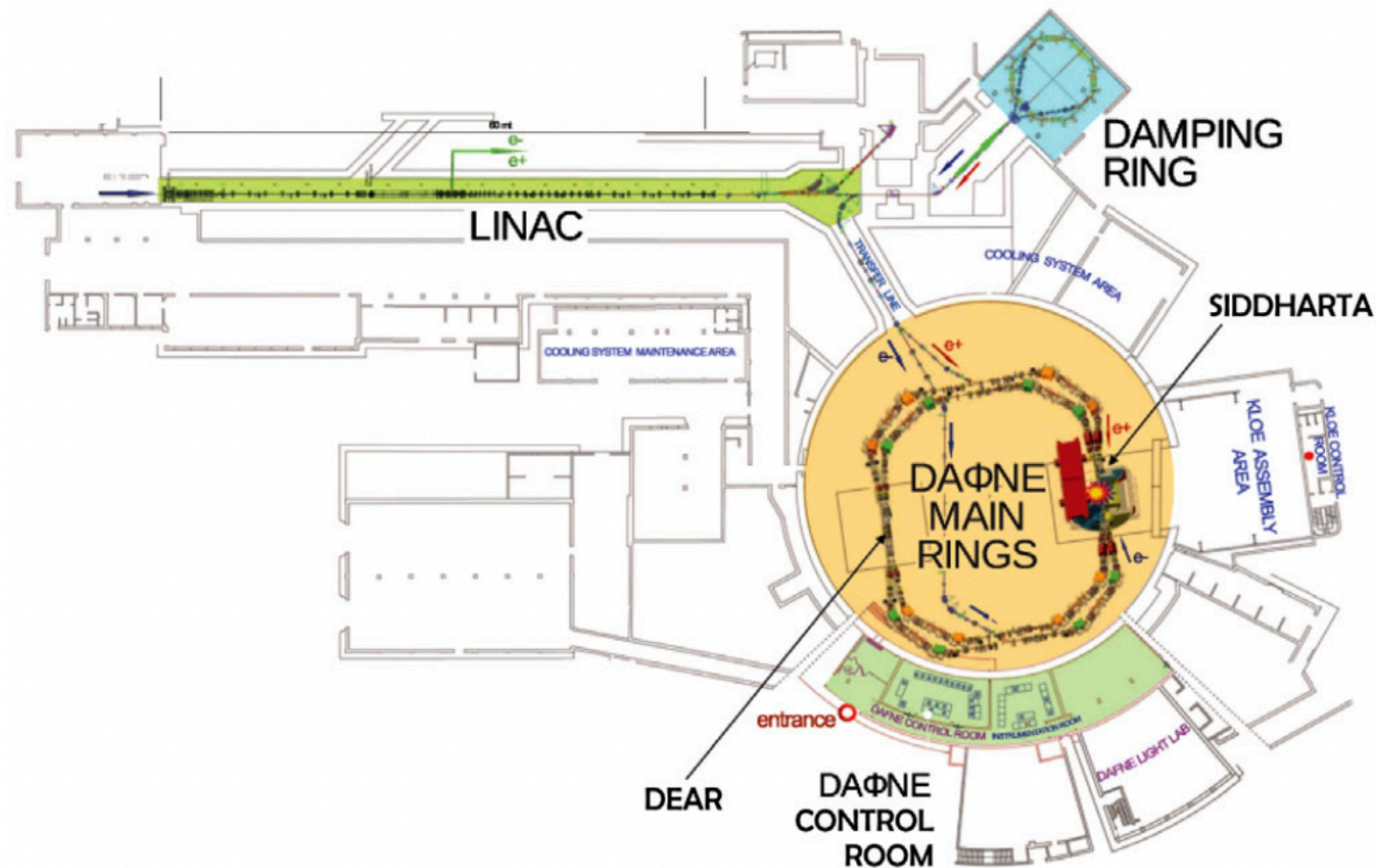

- $e^+e^-$  collider working at a center of mass energy of the  $\phi$  meson mass ( $1.02 \text{ GeV}/c^2$ )
- Decay to  $K^+K^-$  pairs with a BR of 48.9%, back-to-back emission
- Momentum spread of charged kaons  $\Delta p/p < 0.1 \%$
- **Kaon momentum  $127 \text{ MeV}/c$**
- Not (much) relativistic  $\beta \sim 0.25$ ,  $\beta\gamma \sim 0.26$

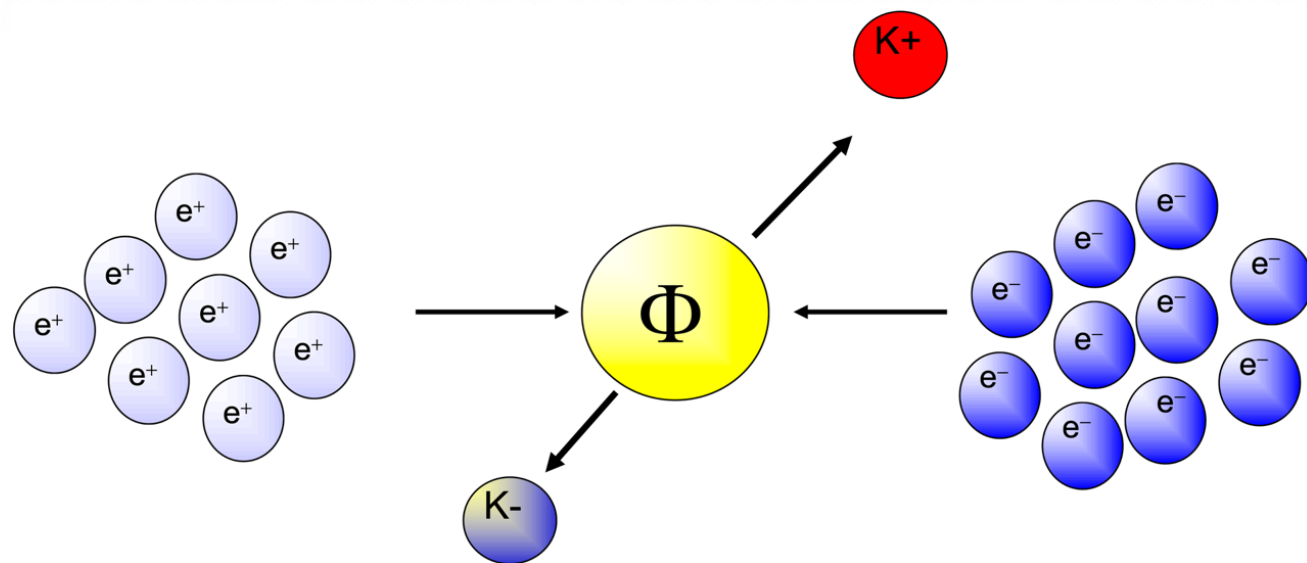

# The SIDDHARTA-2 apparatus

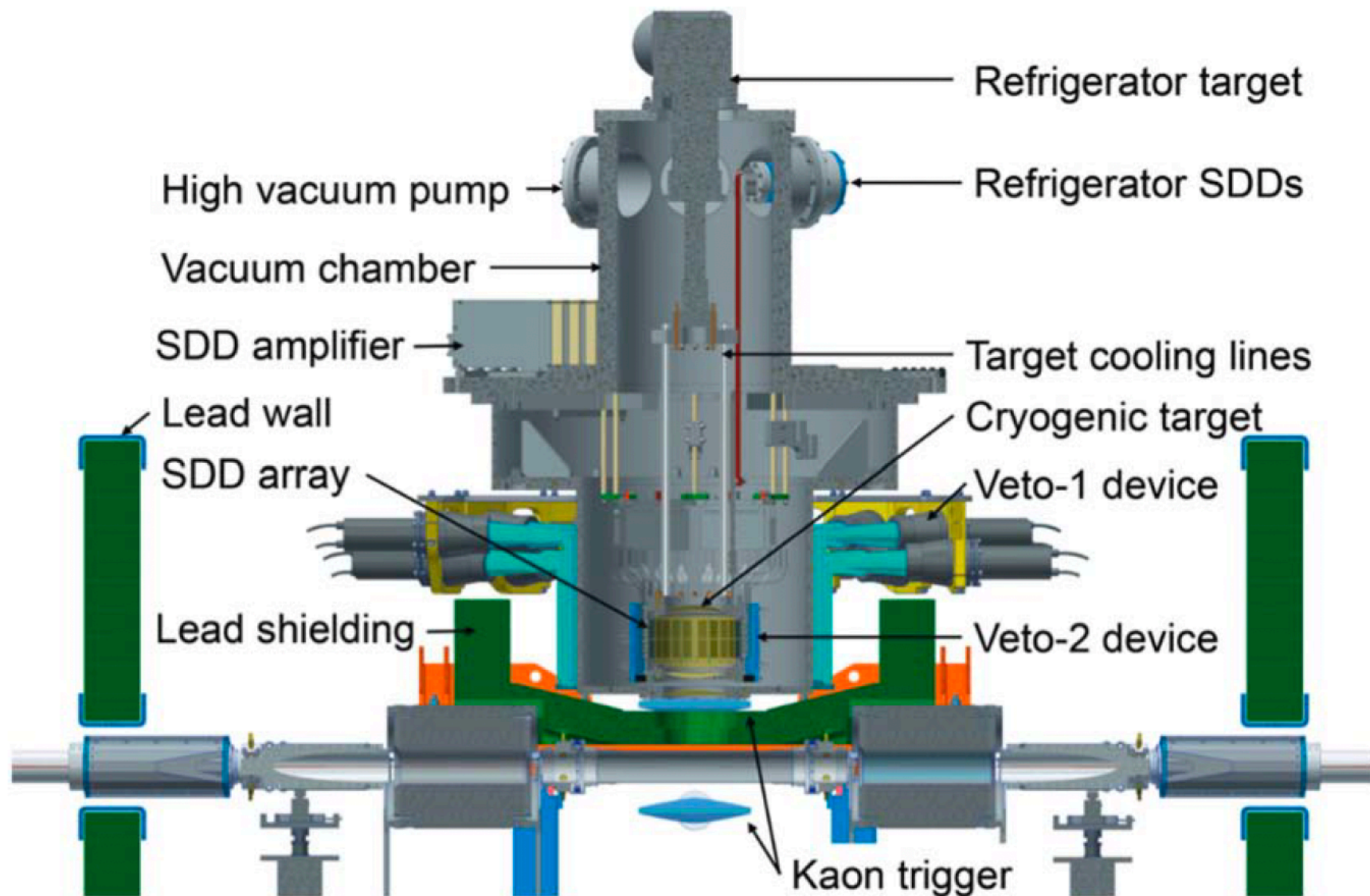

- Cylindrical vacuum chamber
- Cryogenic target cell
- Kaon trigger
- 384 X-Ray detectors (SDDs)
- Mylar degrader
- Luminosity monitor
- Veto Systems

# The SIDDHARTA-2 apparatus

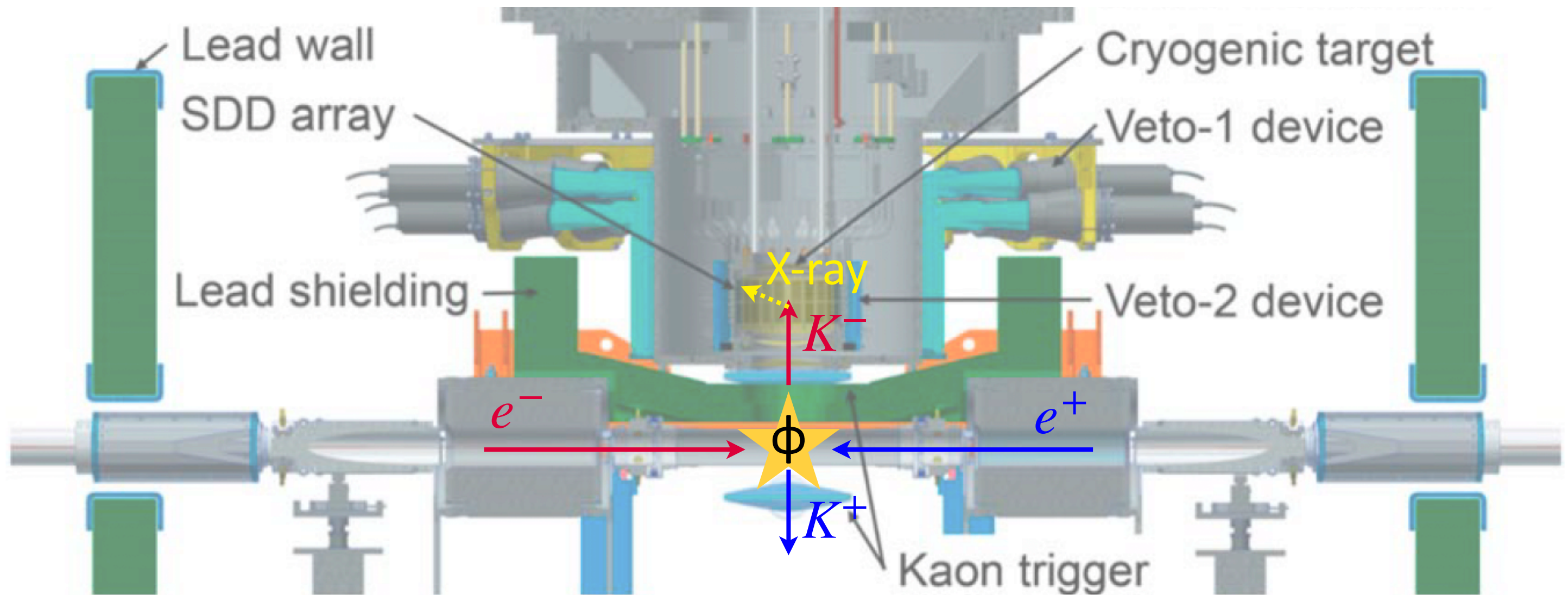

# BSQED precision studies with Kaonic Atoms

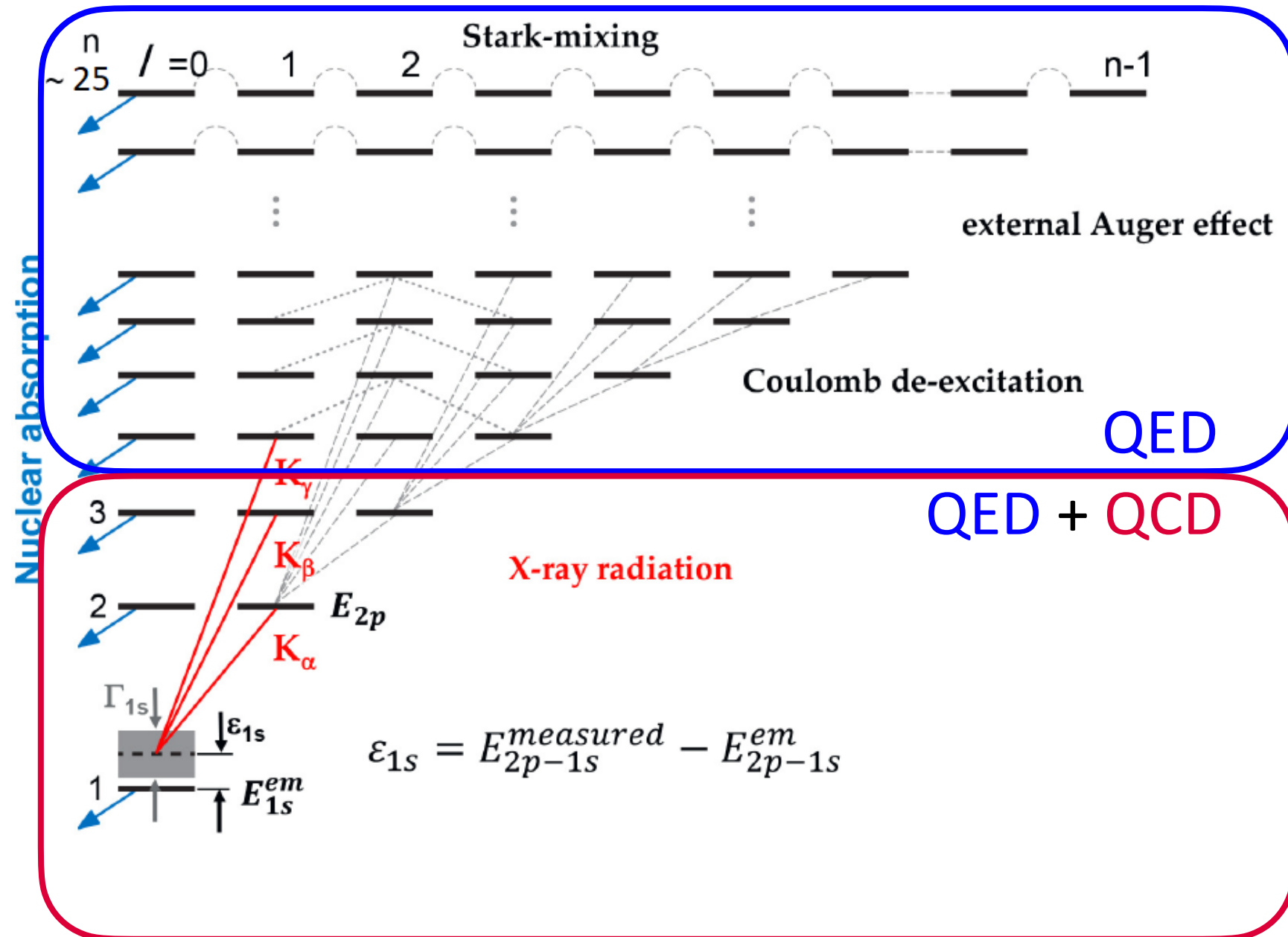

- High- $n$  levels transitions do not experience strong-interaction effects
- Kaonic atoms can be used to provide precision measurements of **bound-state QED**
- Compelling alternative to other exotic atoms and HCl

# BSQED precision studies with Kaonic Atoms

## Highly Charged Ions

- They provide extremely strong electromagnetic fields and allow tests of BSQED in the high-Z regime
- Production and confinement require complex facilities
- Precision of **QED contributions is comparable in magnitude to FNS effects**
- Overall experimental accuracy limited

[*J. Phys. B* 52 (2019) 232001]

## Kaonic Atoms

- Allow to observe transitions with **BSQED effects highly amplified**
- **Spinless particles**
- No hyperfine splitting, easier spectral analysis
- Specific transitions of kaonic atoms to minimise the influence of FNS effects and residual electrons (screening)

# BSQED precision studies with Kaonic Atoms

## Highly Charged Ions

- They provide extremely strong electromagnetic fields and allow tests of BSQED in the high-Z regime
- Production and confinement require complex facilities
- Precision of **QED contributions is comparable in magnitude to FNS effects**
- Overall experimental accuracy limited

[*J. Phys. B* 52 (2019) 232001]

## $\mu$ , $\pi$ , $\bar{p}$ - Atoms

- Larger mass of the exotic particle ( $\gg m_e$ ) enable probing regions closer to the nucleus
- BSQED effects are **enhanced**
- $\mu^-$  and  $\bar{p}$  are spin -  $\frac{1}{2}$  particles, **hyperfine splitting** of the energy levels
- $\pi^-$  still has a **small mass**

[*Phys. Rev. Lett.* 126 (2021) 173001]

# BSQED precision studies with Kaonic Atoms

## Highly Charged Ions

- They provide extremely strong electromagnetic fields and allow tests of BSQED in the high-Z regime
- Production and confinement require complex facilities
- Precision of **QED contributions is comparable in magnitude to FNS effects**
- Overall experimental accuracy limited

[*J. Phys. B* 52 (2019) 232001]

## $\mu$ , $\pi$ , $\bar{p}$ - Atoms

- Larger mass of the exotic particle ( $\gg m_e$ ) enable probing regions closer to the nucleus
- BSQED effects are **enhanced**
- $\mu^-$  and  $\bar{p}$  are spin -  $\frac{1}{2}$  particles, **hyperfine splitting** of the energy levels
- $\pi^-$  still has a **small mass**

[*Phys. Rev. Lett.* 126 (2021) 173001]

## Kaonic Atoms

- Allow to observe transitions with **BSQED effects highly amplified**
- **Spinless particles**
- No hyperfine splitting, easier spectral analysis
- Specific transitions of kaonic atoms to minimise the influence of FNS effects and residual electrons

[*Phys. Lett. B* 865 (2025) 139492]

# BSQED Studies with Kaonic Neon

[*Phys. Lett. B* 865 (2025) 139492]

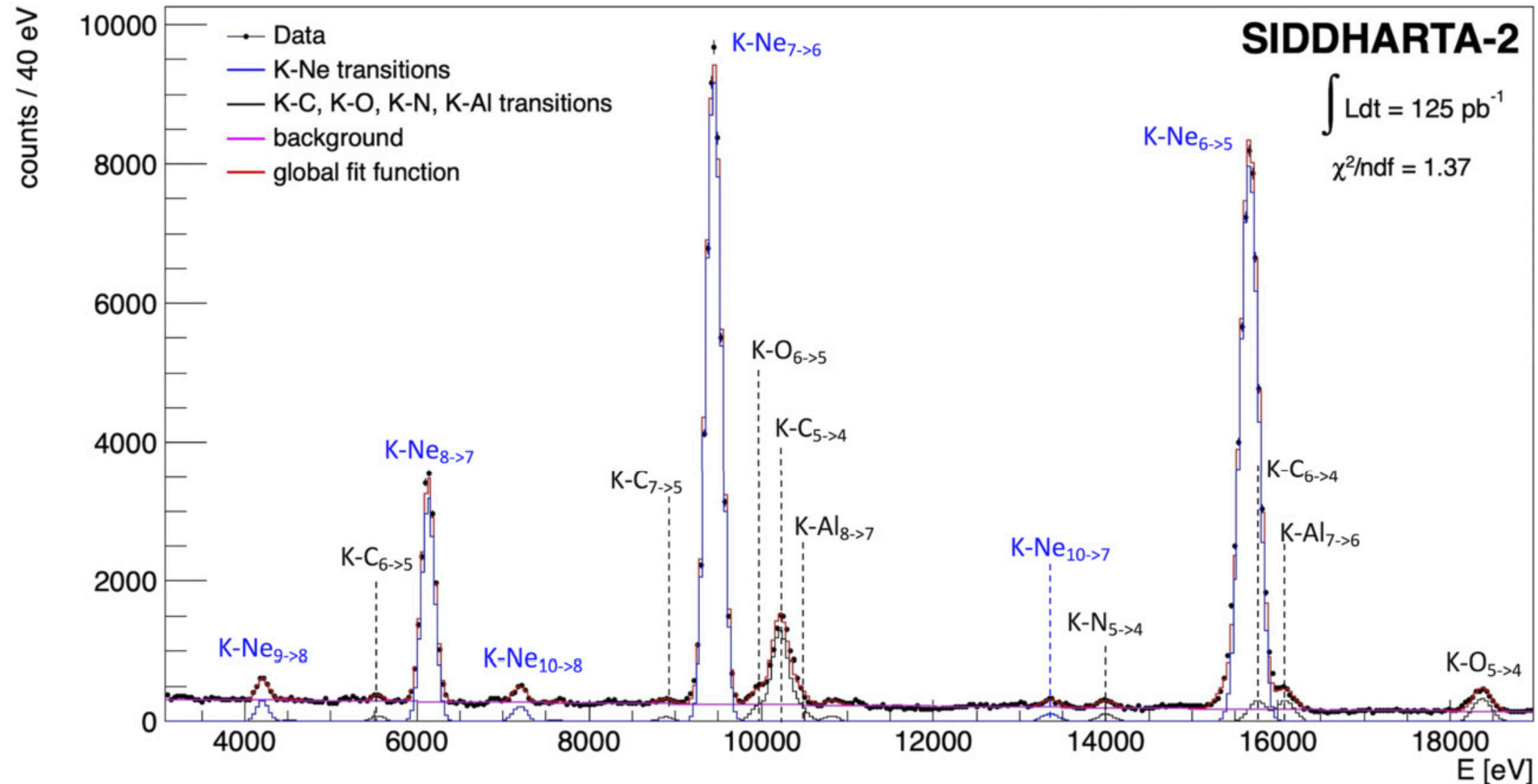

- Demonstrates the feasibility of precision studies of QED with kaonic atoms
- Precision tests of **BSQED** in atomic systems with strangeness
- Testing for deviation hinting at **BSM physics** [*Phys. Rev. Lett.* 135, 131803 (2025)]
- Measurement of the **charged Kaon Mass**

# BSQED Studies with Kaonic Neon (refined)

[Phys. Rev. A 113, 022815]

Refined analysis of the full Kaonic Neon dataset

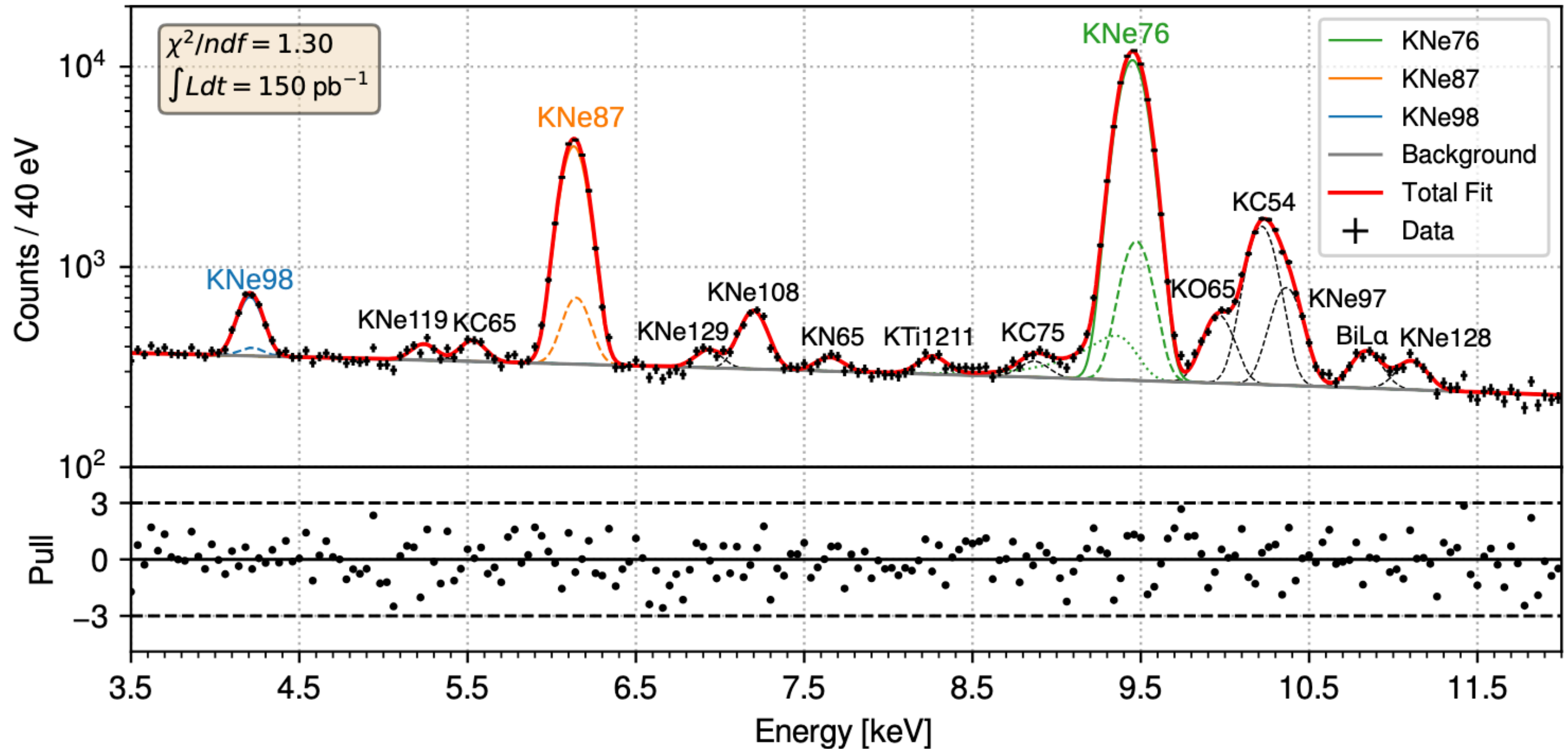

# BSQED Studies with Kaonic Neon (refined)

[Phys. Rev. A 113, 022815]

Transition	$E_{if}^{(exp.)}$	$\delta E_{if}^{(stat.)}$	$\delta E_{if}^{(sys.)}$	$E_{if}^{(calc.)}$	$E_{if}^{(QED)}$	$E_{if}^{(QED1)}$	$E_{if}^{(QED2)}$	$\Delta E_{if}^{(isot.)}$	$\Delta E_{if}^{(screen.)}$	$\Delta E_{if}^{(PDG)}$
9l-8k	4206.97	3.43	2.00	4201.45	2.09	2.07	0.02	9.90	-0.38	0.11
8k-7i	6130.57	0.65	1.50	6130.31	5.09	5.05	0.04	14.45	-0.27	0.16
7i-6h	9450.23	0.37	1.50	9450.28	12.66	12.56	0.10	22.28	-0.18	0.24
6h-5g <sup>a</sup>	15673.30	0.52	9.00	15685.39	32.75	32.51	0.24	37.01	-0.11	0.40

- **MCDF calculations** include transition energies, QED effects, Electron Screening, Isotopic Shifts ( $K^{20}Ne$ ,  $K^{22}Ne$ ) and Kaon mass  
[Computer Physics Communications 9 (1975) 3 1-45, Phys. Rev. A 42.9 (1990) 5139.]
- **Sub-eV Statistical Uncertainties** match the scale of Second-Order QED corrections
- **Kaonic Neon offers a clean system to test QED calculations and constrain BSM scenarios.**

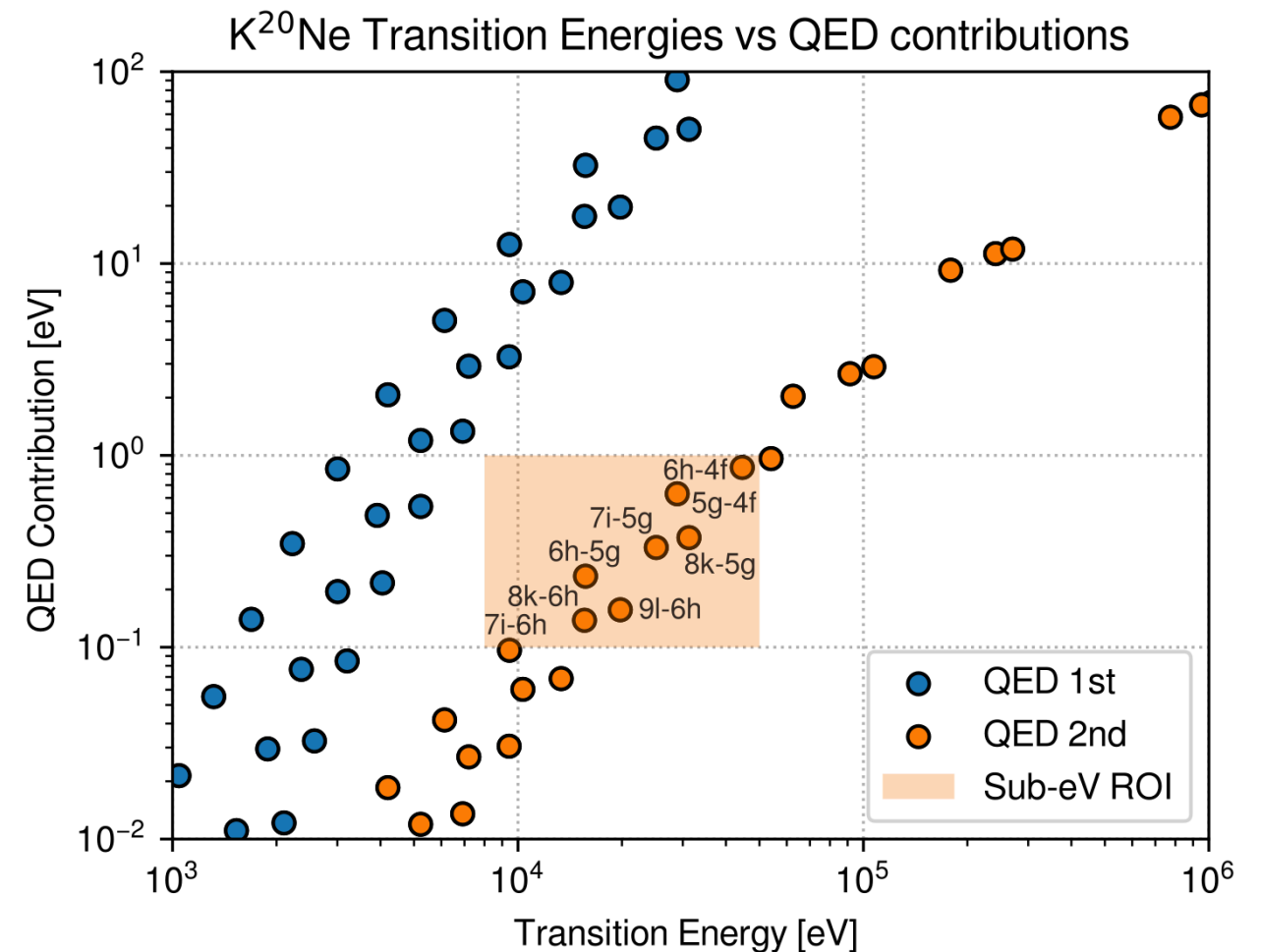

# The Charged Kaon Mass problem

---

Charged kaon mass ( $K^+$ ,  $K^-$ )

$$493.677 \pm 0.013 \text{ MeV}$$

P.a. Zyla et al. (Particle Data Group), Prog.Theor. Exp. Phys. 2020, 083C01 (2020)

# The Charged Kaon Mass problem

---

Charged kaon mass ( $K^+$ ,  $K^-$ )

~~493.677 ± 0.013 MeV~~

P.a. Zyla et al. (Particle Data Group), Prog.Theor. Exp. Phys. 2020, 083C01 (2020)

# The Charged Kaon Mass problem

**WEIGHTED AVERAGE**  
 $493.677 \pm 0.013$  (Error scaled by 2.4)

$$m_{K^\pm} = 493.696 \pm 0.007 \text{ MeV} \quad \text{DENISOV 91}$$

DENISOV 91

$$m_{K^\pm} = 493.636 \pm 0.011 \text{ MeV} \quad (S = 1.5) \quad \text{GALL 88}$$

Values above of weighted average, error, and scale factor are based upon the data in this ideogram only. They are not necessarily the same as our 'best' values, obtained from a least-squares constrained fit utilizing measurements of other (related) quantities as additional information.

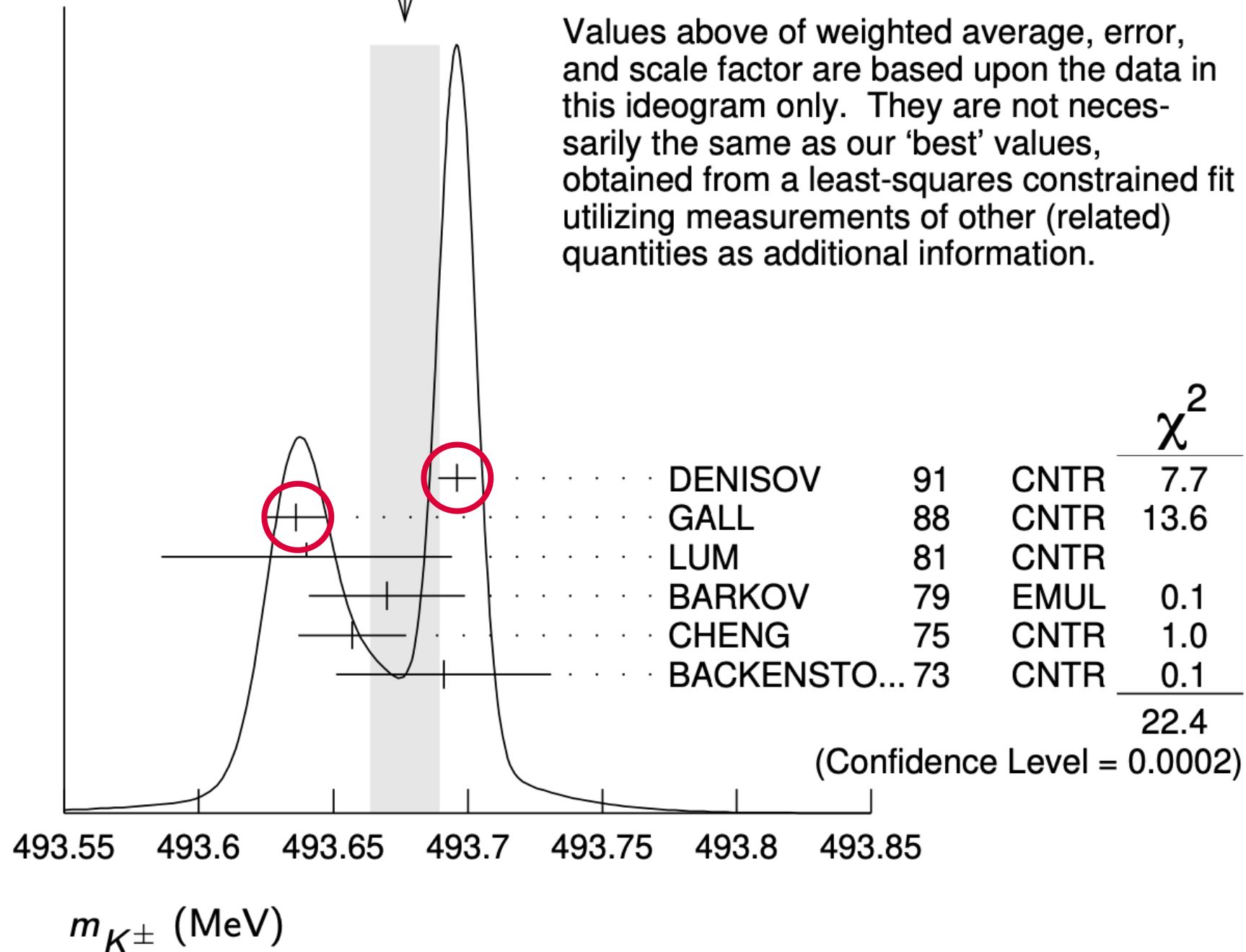

# QED Studies: Charged Kaon Mass

- MCDF calculations to iteratively extract the kaon mass from measured transitions (as in GALL88)

- Gaseous Neon target grants **better control over systematics**

- Low-Z means FNS negligible with respect to Pb

- KNe is completely ionized, no screening

- No electron refill effect in a gas

[*Phys. Rev. A* 113, 022815]

$$M_{K^-} = 493.677 \pm 0.018(\text{stat}) \pm 0.066(\text{syst}) \text{ MeV}$$

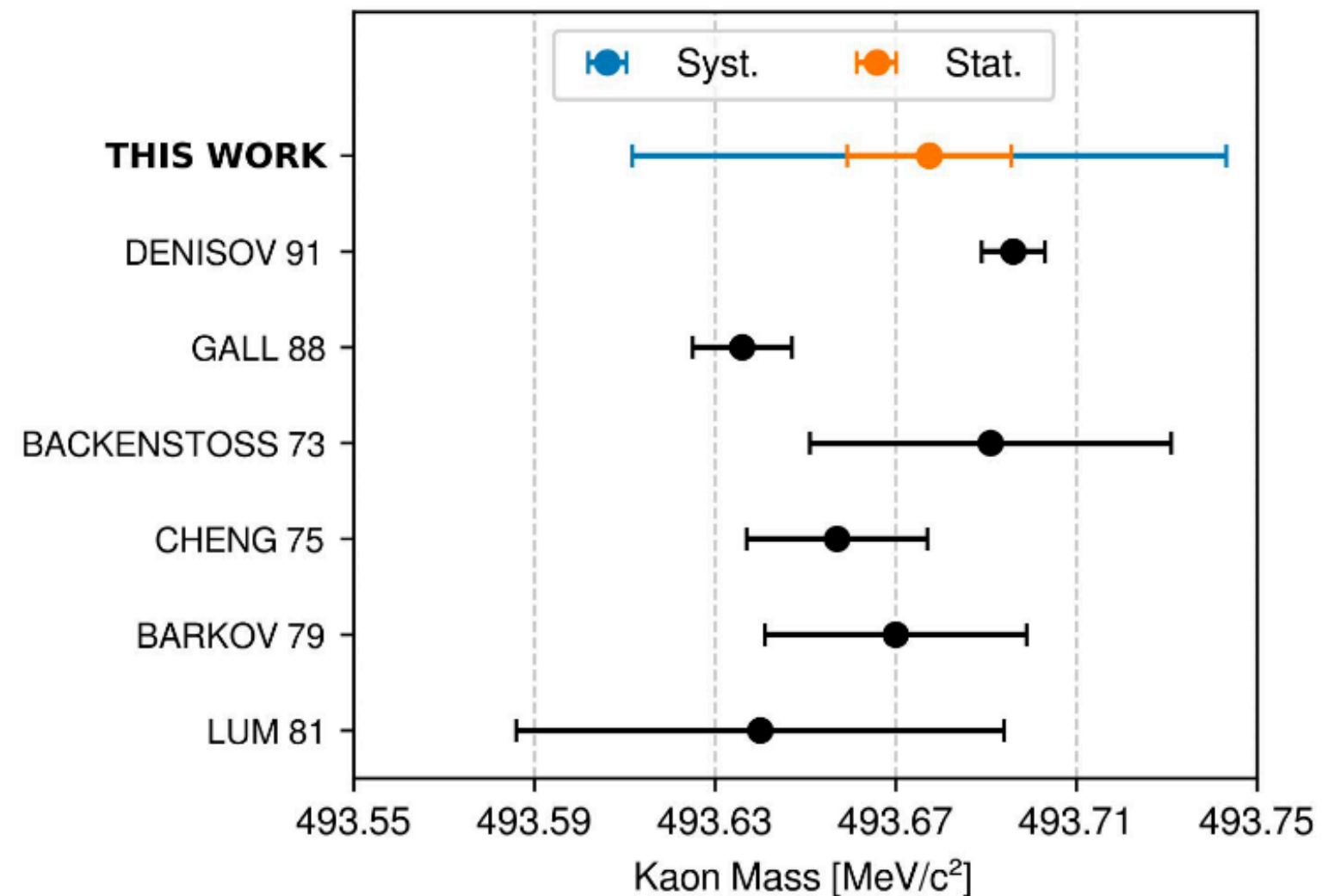

# Future plans: beyond SIDDHARTA-2

## 1.1 - High precision kaonic neon measurement

To extract the charged kaon mass with a precision of about 5 keV

**BSQED and Physics beyond Schwinger limit**

## 1.2 - Light kaonic atoms (LHKA)

– solid target **Li, Be, B**

– integration of 1mm SDD

# EXKALIBUR

*C. Curceanu et al., Front.in Phys. 11 (2023) 1240250*

**EX**tensive  
**K**aonic  
**A**toms research: from  
**L**ithium and  
**B**eryllium to  
**UR**anium

## Intermediate kaonic atoms (IMKA)

**In parallel** we plan dedicated runs for kaonic atoms (O, Al, S) with **CdZnTe detectors**  
- 200 -300 pb<sup>-1</sup> of integrated luminosity/target

- Minimal modifications/addings to SIDDHARTA-2
- New **calibration system** (0.2 eV accuracy)
- New **1mm thick SDDs** (characterization ongoing)
- Better detection efficiency at higher energies

# Future plans: the charged kaon mass puzzle

## 1.1 - Kaon mass by Kaonic neon measurement

- Use the SIDDHARTA2 setup
- 300 pb<sup>-1</sup> of integrated luminosity

- First goal: measurement of **kaonic neon** high-n levels transition with precisions **below 1 eV**
- Achievable with new calibration system
- Kaon mass with a  $\sim 5$  keV precision
- **Gaseous target** to resolve ambiguities in the kaon mass determination

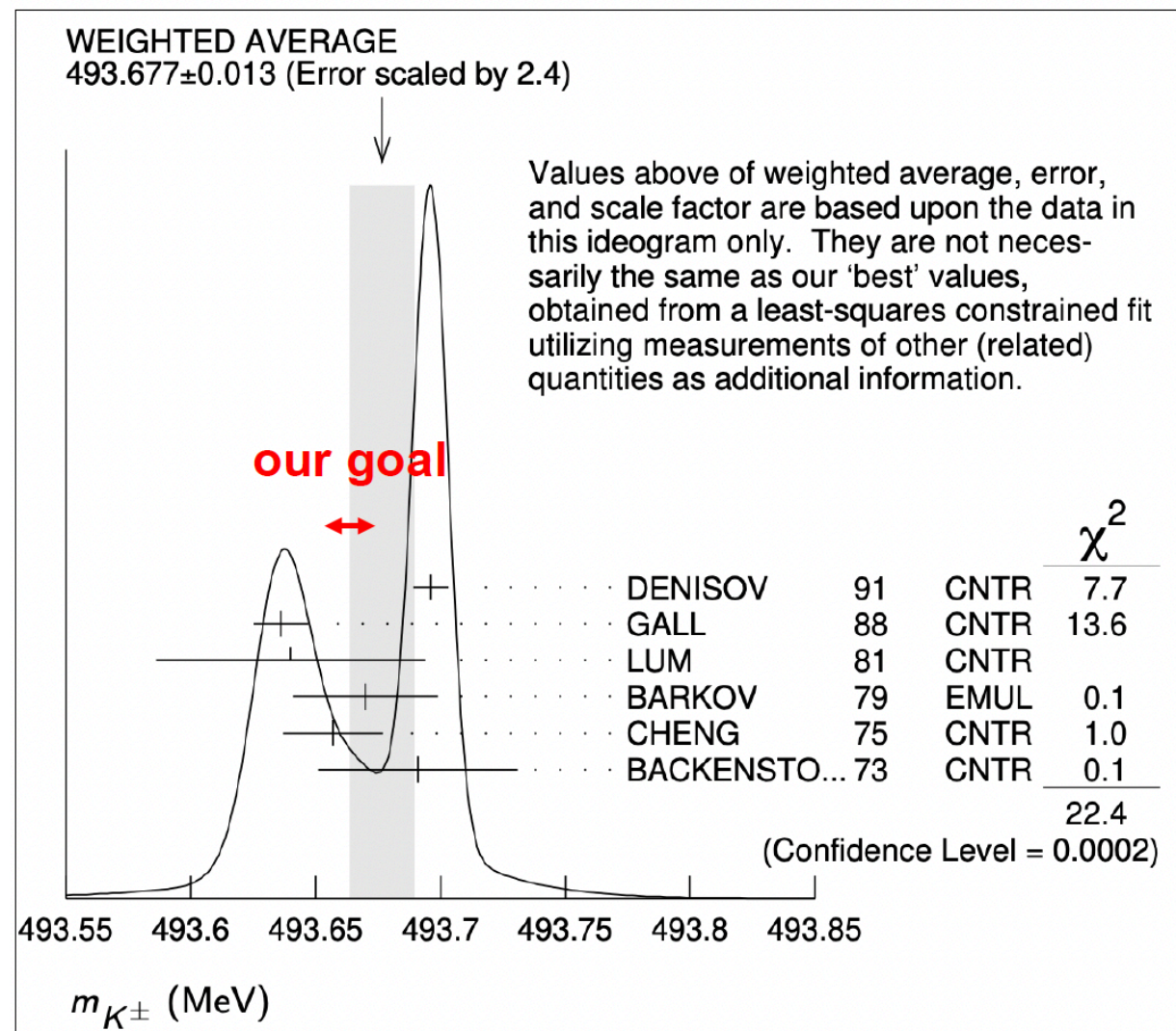

# Strong Field QED with Kaonic Atoms

- Bohr radius in kaonic atoms is much smaller

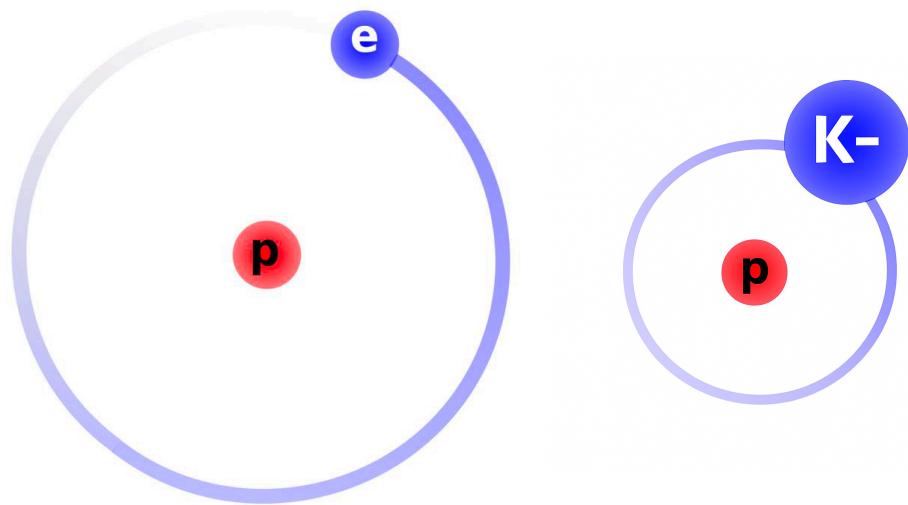

Particle	$m$ [MeV/c <sup>2</sup> ]	$B_{1s}$ [keV]	$r_B$ [ $10^{-15}$ m]	Accessible interactions
$e p$	0.511	$13.6 \times 10^{-3}$	$0.53 \times 10^5$	Electro-weak
$\mu p$	105.7	2.53	279	Electro-weak
$\pi p$	139.6	3.24	216	Electro-weak + strong
$K p$	493.7	8.61	81	Electro-weak + strong
$\bar{p} p$	938.3	12.5	58	Electro-weak + strong

- The electric field between the kaon and the nucleus is  $O(10^5)$  greater than that of “normal” atoms

- Studies of BSQED in strong fields with kaonic atoms**

- $E_c = \frac{m_e^2 c^3}{e \hbar} \approx 1.3 \times 10^{18} \text{ V/m}$  critical value: Schwinger Limit

# Strong Field QED with Kaonic Atoms

- QED in presence of a strong background EM field described by the Euler-Heisenberg Lagrangian [*Progress in Particle and Nuclear Physics* 133 (2023): 104068., *arXiv:hep-th/0406216v1*]
- **Non-linear terms** arise, VP, SE corrections **amplified**
- Vacuum becomes **unstable against spontaneous  $e^+e^-$  creation** + other effects induced: **light-by-light scattering, vacuum birefringence**, etc.

$$S^{(1)} = \frac{e^4}{360\pi^2 m^4} \int d^4x \left[ (\vec{E}^2 - \vec{B}^2)^2 + 7(\vec{E} \cdot \vec{B})^2 \right] + \dots$$

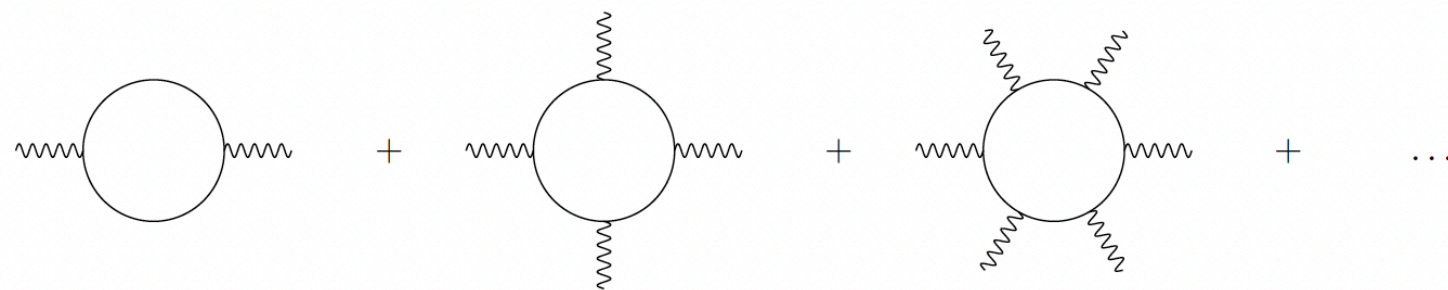

- Fields exceeding the Schwinger limit can be found in **extreme astrophysical scenarios** (e.g. neutron stars' surfaces, black holes [*Phys. Rev. Lett.* 135, 131803 (2025), *Astrophys. J. Lett.* 985, 2 (2025)])

# Strong Field QED with Kaonic Atoms

- Community effort to measure such EM fields with ultra-intense lasers and exotic atoms experiments

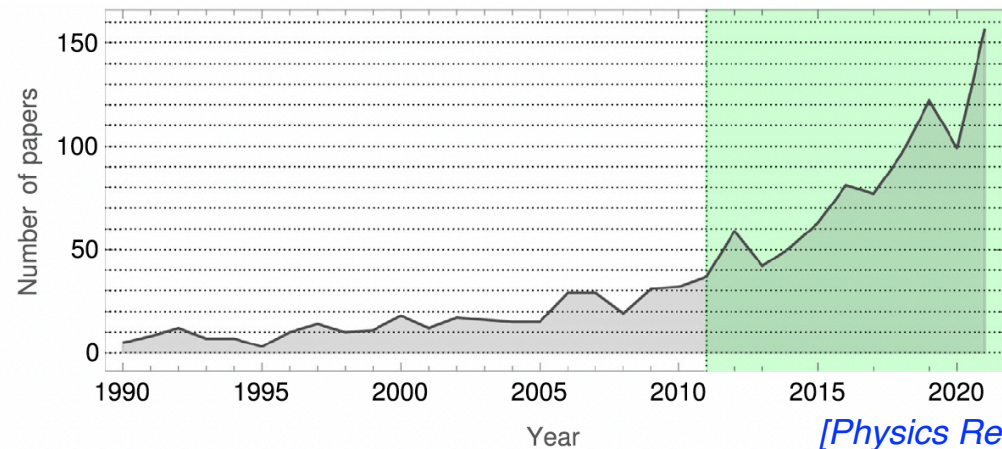

[Physics Reports 1010 (2023) 1–138]

Fig. 1. Indicative bibliometric search using NASA-ADS, for at least one of the following terms occurring in the abstract: “strong field QED”, “nonlinear QED”, “nonlinear Compton”, “nonlinear Breit-Wheeler”, “locally constant field”, “Schwinger effect”, “Schwinger pair”. The shaded region is the last decade, on which the current review is focussed.

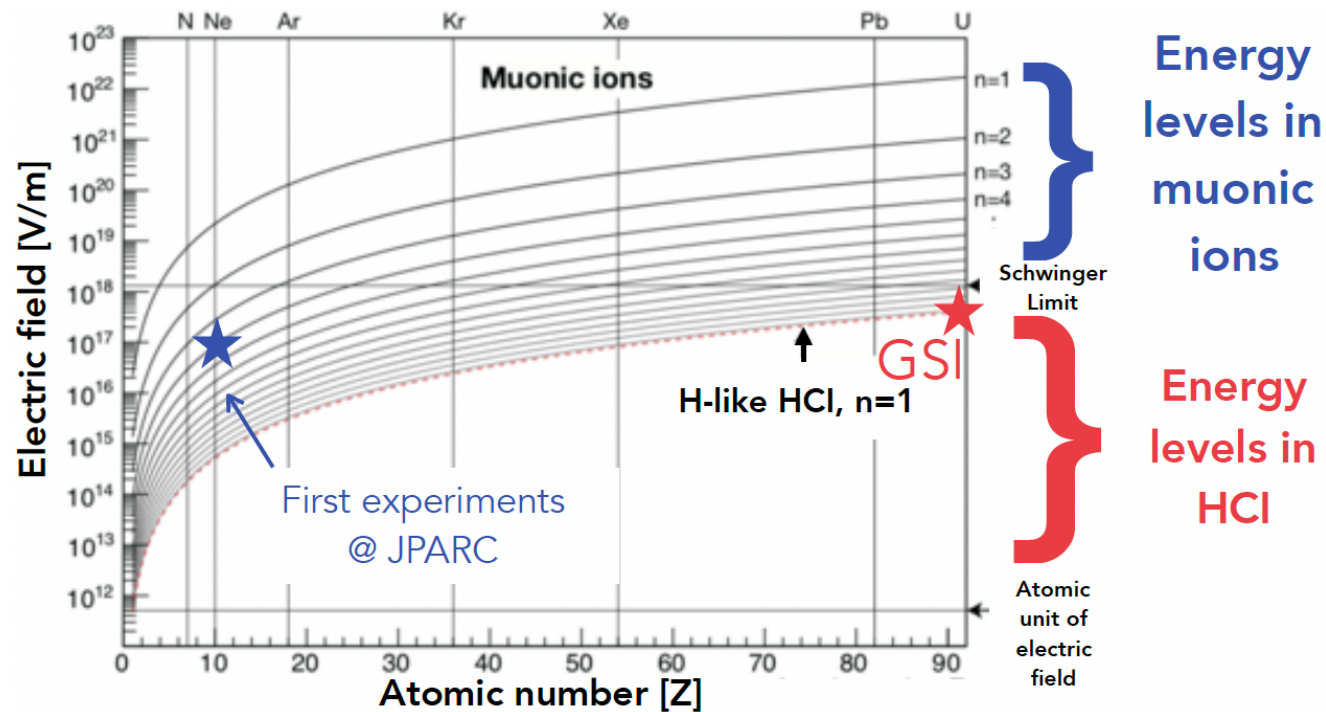
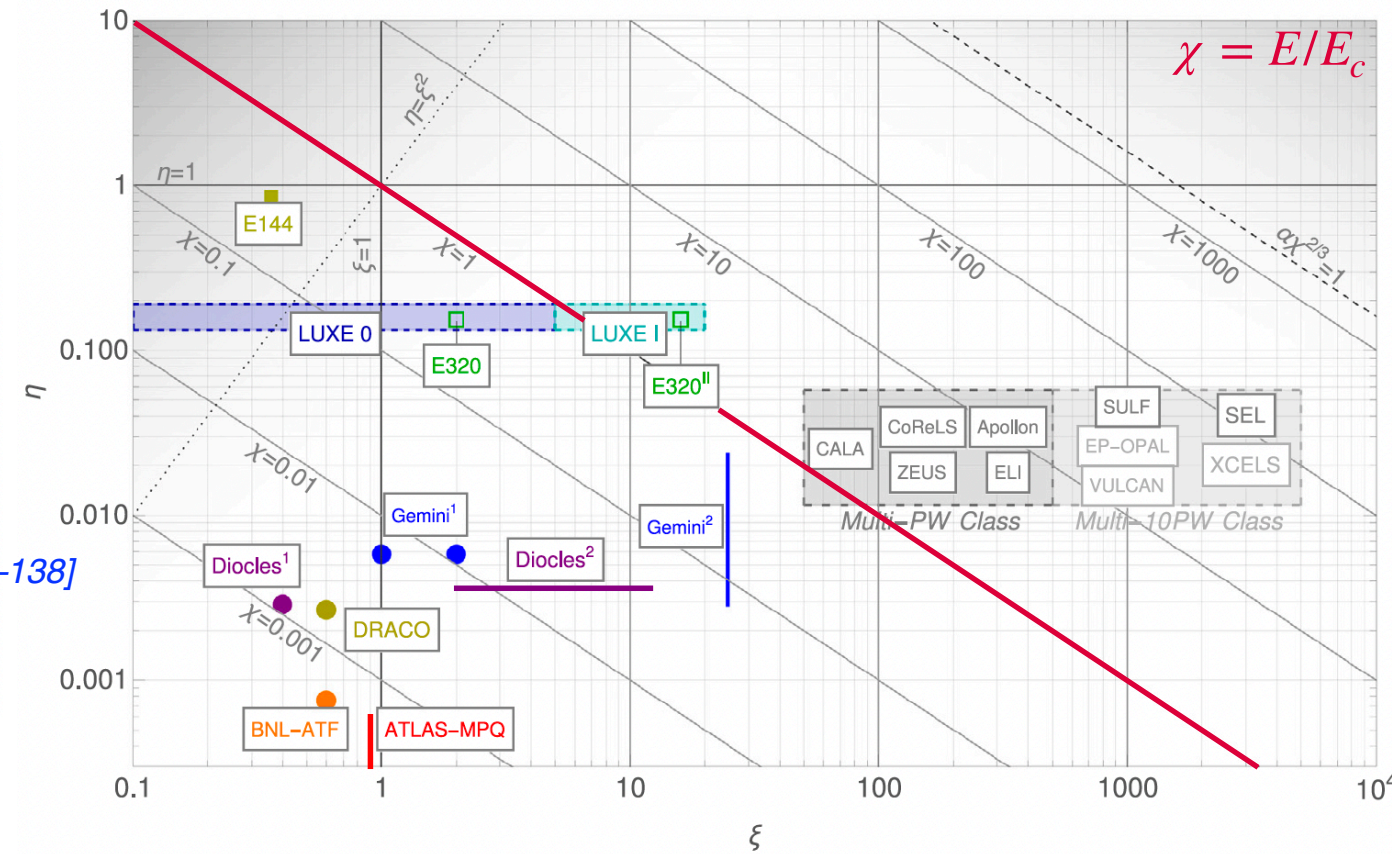

**Abstract:** PAX (antiProtonic Atom X-ray spectroscopy) is a new experiment with the aim to test strong-field quantum electrodynamics (QED) effects by performing high-precision x-ray spectroscopy of antiprotonic atoms. By utilizing advanced microcalorimeter detection techniques and a low-energy antiproton beam provided by the ELENA ring at CERN, gaseous targets will be used for the creation of antiprotonic atoms, and the measurement of transitions between circular Rydberg states will be conducted with up to two orders of magnitude improved accuracy over previous studies using high-purity germanium detectors. Our approach eliminates the longstanding issue of nuclear uncertainties that have hindered prior studies using highly charged ions, thus enabling direct and purely QED-focused measurements. By precisely probing atomic systems with electric fields up to two orders of magnitude above the Schwinger limit, PAX will test vacuum polarization and second-order QED corrections, opening new frontiers in fundamental physics and uncovering potential pathways to physics beyond the Standard Model. [PoS EXA-LEAP2024 (2025) 085]

# Probing QED beyond the Schwinger Limit with KF

[arXiv:2604.19387]

Measurement of **Kaonic Fluorine** X-ray transitions in the 10-50 keV range

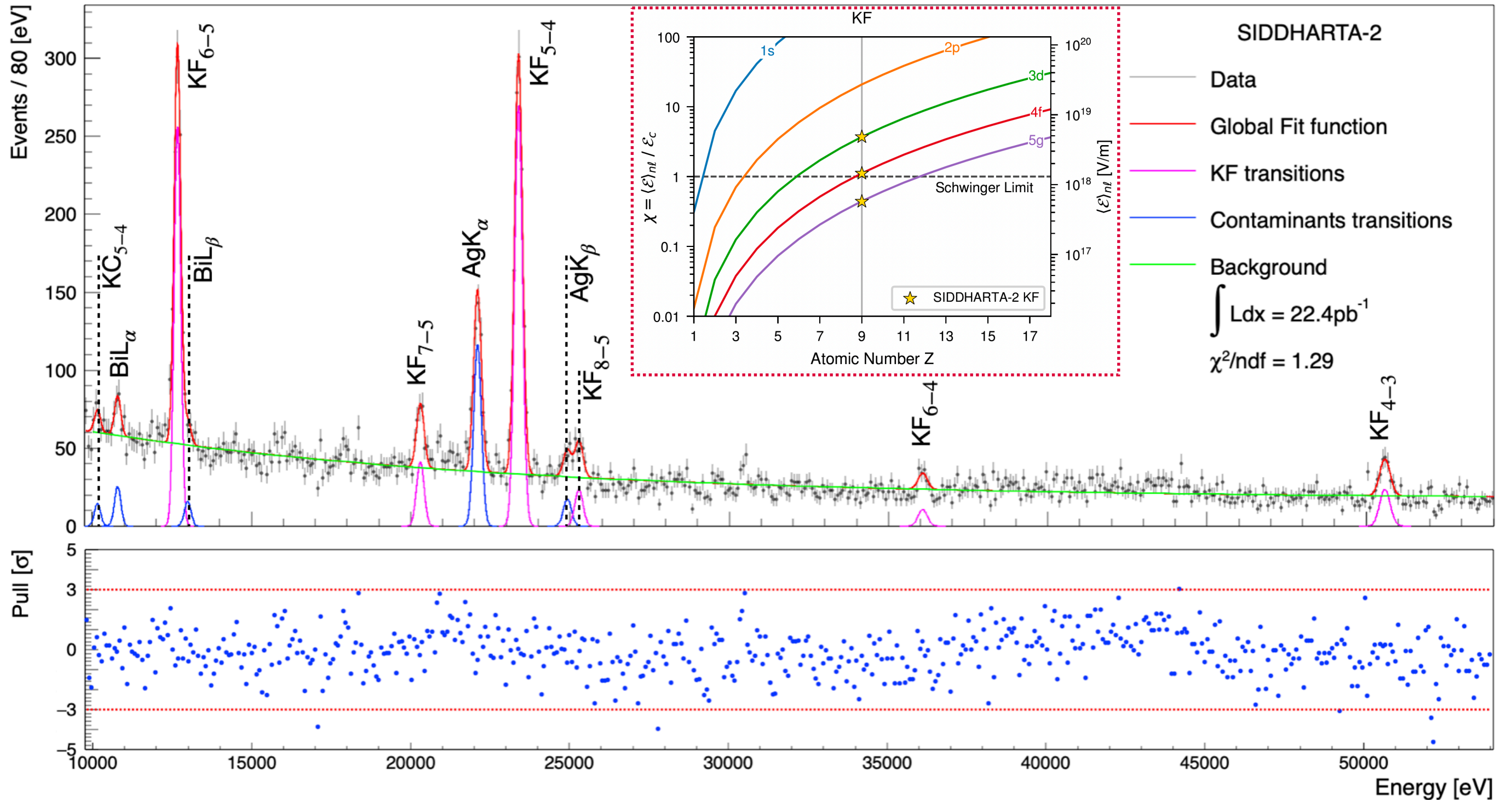

# Probing QED beyond the Schwinger Limit with KF

[arXiv:2604.19387]

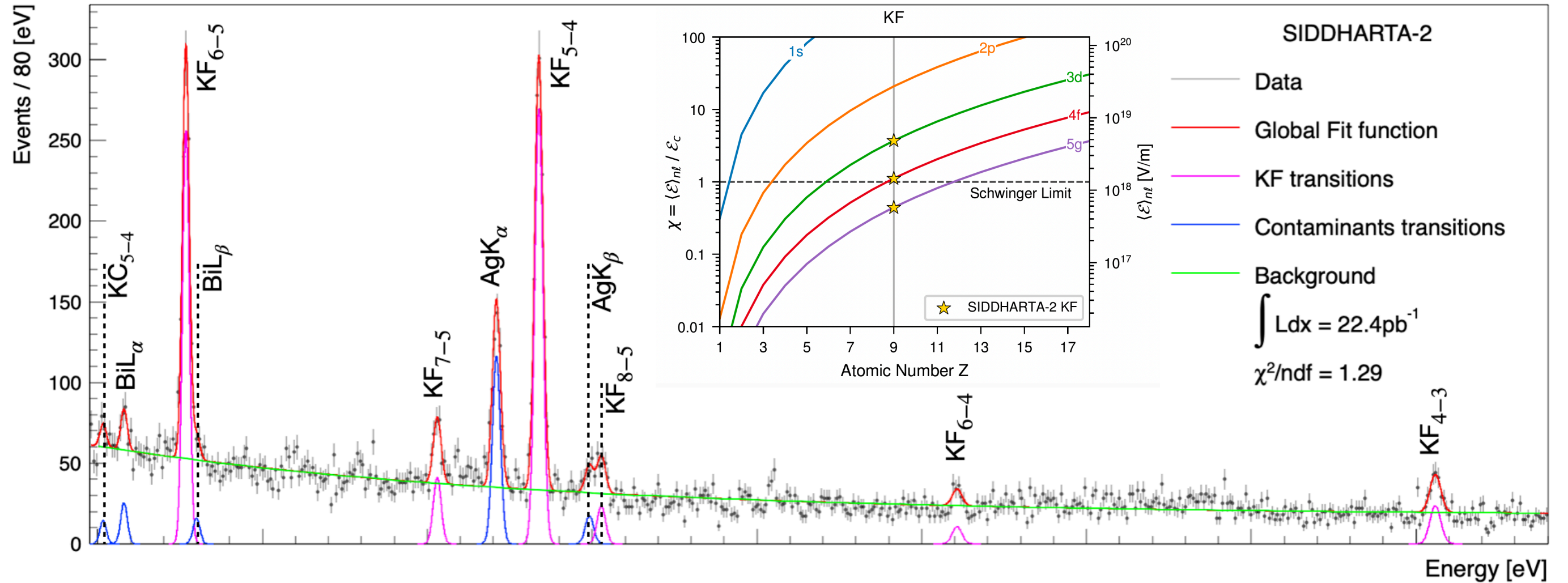

Transition	$E_{if}^{(exp.)}$	$\delta E_{if}^{(stat.)}$	$\delta E_{if}^{(sys.)}$	$E_{if}^{(calc.)}$	$E_{if}^{(QED)}$	$E_{if}^{(QED1)}$	$E_{if}^{(QED2)}$	FNS	PDG	Screen.	HFS
6h-5g	12673.9	5.9	7.1	12684.69	23.49	23.31	0.17	0.01	0.33	-0.09	0.27
7i-5g	20298.8	16.3	6.0	20327.49	32.26	32.02	0.24	0.01	0.52	-0.25	0.27
5g-4f	23383.2	4.7	5.5	23377.38	67.54	67.07	0.47	0.03	0.60	-0.04	0.87
8k-5g	25279.6	36.2	5.0	25285.56	35.65	35.38	0.27	0.01	0.65	-0.48	0.27
6h-4f	36073.3	30.7	30.0	36062.07	91.02	90.38	0.64	0.04	0.93	-0.13	0.87
4f-3d	50586.7	24.3	23.0	50590.48	222.99	221.45	1.54	0.13	1.30	0.01	4.16

# Probing QED beyond the Schwinger Limit with KF

[arXiv:2604.19387]

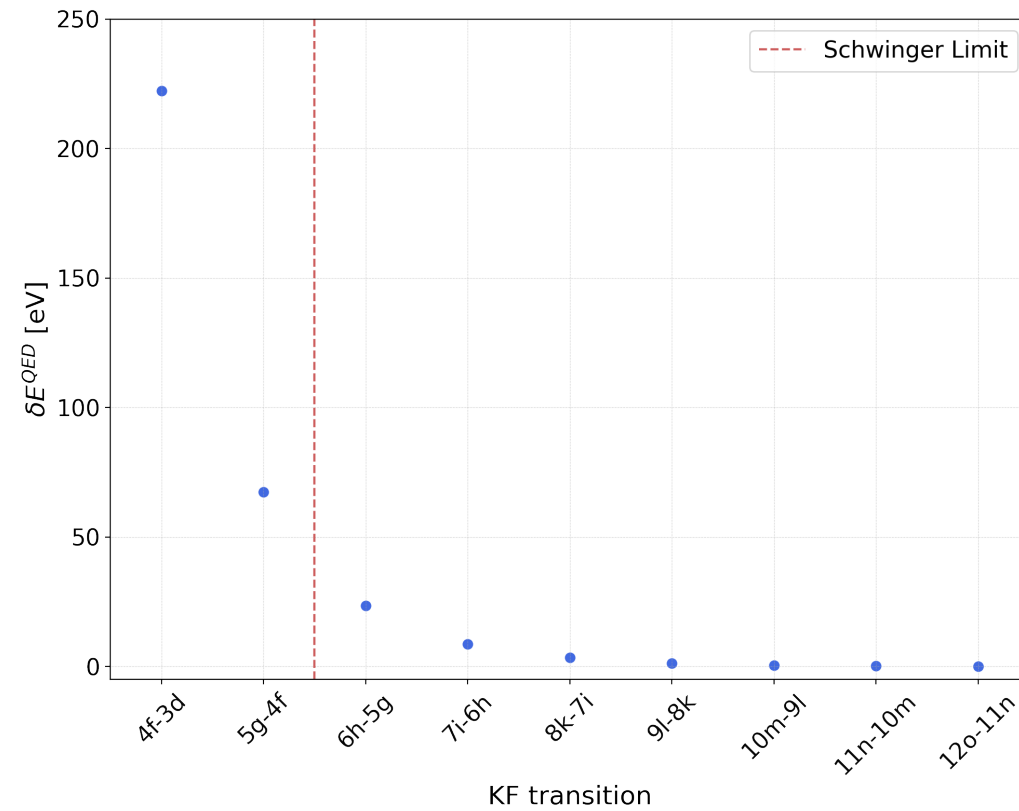
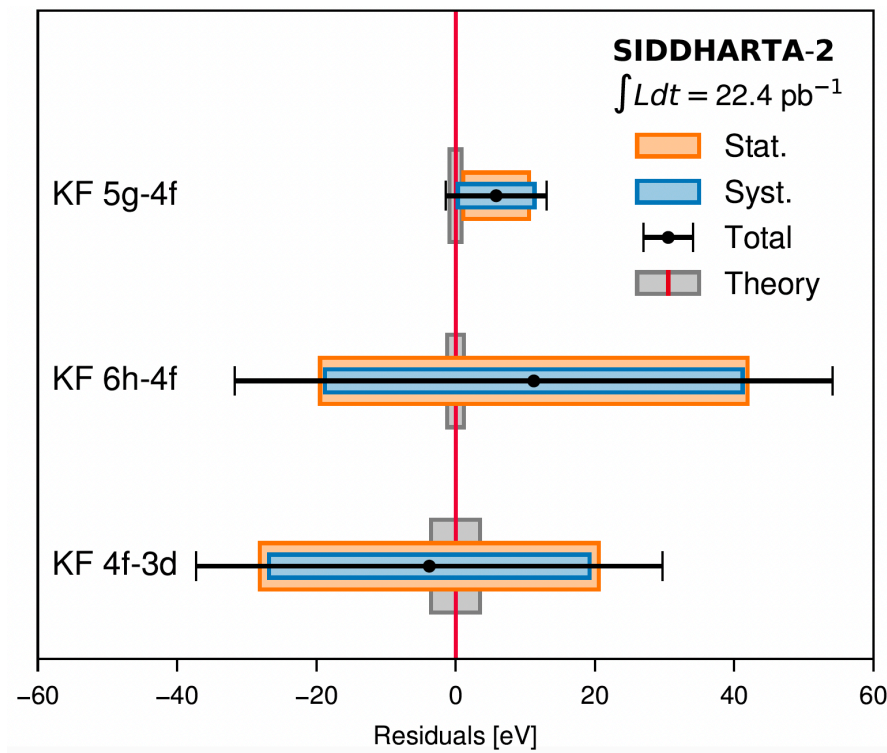

Line	$E_{if}^{(\text{exp.})} \pm (\text{stat.}) \pm (\text{sys.})$	$E_{if}^{(\text{calc.})} \begin{smallmatrix} +\delta_{if}^+ \\ -\delta_{if}^- \end{smallmatrix}$	$E_{if}^{(\text{QED})}$
6h-5g	$12673.9 \pm 5.9 \pm 7.1$	$12684.69_{-0.43}^{+0.42}$	23.49
7i-5g	$20298.8 \pm 16.3 \pm 6.0$	$20327.49_{-0.64}^{+0.59}$	32.26
5g-4f	$23383.2 \pm 4.7 \pm 5.5$	$23377.38_{-1.06}^{+1.06}$	67.54
8k-5g	$25279.6 \pm 36.2 \pm 5.0$	$25285.56_{-0.85}^{+0.70}$	35.65
6h-4f	$36073.3 \pm 30.7 \pm 30.0$	$36062.07_{-1.28}^{+1.27}$	91.02
4f-3d	$50586.7 \pm 24.3 \pm 23.0$	$50590.48_{-4.36}^{+4.36}$	222.99

State $nl$	$\langle r \rangle_{nl}$ [fm]	$\langle \mathcal{E} \rangle_{nl}$ [V/m]	$\chi = \langle \mathcal{E} \rangle_{nl} / \mathcal{E}_c$
KF-3d	66	$4.91 \times 10^{18}$	3.70
KF-4f	113	$1.48 \times 10^{18}$	1.11
KF-5g	172	$0.59 \times 10^{18}$	0.44
KF-6h	244	$0.28 \times 10^{18}$	0.21
KF-7i	328	$0.15 \times 10^{18}$	0.06

- Comparison with **all-order MCDF calculations** [*Phys. Rev. A* 113, 022806]
- Agreement with theory for all measured transitions exceeding the Schwinger limit
- $5.8 \pm 4.7$  (stat.)  $\pm 5.5$  (syst.) eV residual on the 5g-4f line (the most intense), corresponding to a  **$\sim 9\sigma$  sensitivity to QED effects**
- **Direct comparison between theory and experiment in the critical strong-field domain of QED**

# Conclusions

---

- Kaonic atoms are extremely powerful systems to conduct research on hadronic physics and BSQED
- DAΦNE delivers **very clean kaon beams**, optimal conditions for studies of kaonic atoms
- **Kaonic Neon** is a powerful and clean tool to conduct studies on BSQED
- Possibility to **settle the charged kaon mass problem** by performing a dedicated Kaonic Neon measurement
- Observation of X-ray transitions in **electric fields above the Schwinger Limit** in exotic atoms with a measurement of **Kaonic Fluorine**
- Sub-per-mille relative precision on the 5g-4f line and  **$\sim 9\sigma$  sensitivity** to QED effects, no deviation found
- **Test of BSQED in the strong-field regime and constraints on BSM physics with kaonic atoms**

# Thank you for your attention



Istituto Nazionale di Fisica Nucleare  
Laboratori Nazionali di Frascati



**FRANCESCO CLOZZA** on behalf of the *SIDDHARTA-2* collaboration  
International Conference on Precision Physics of Simple Atomic Systems

# SPARE SLIDES

# MCDF calculations

## Ab Initio Input

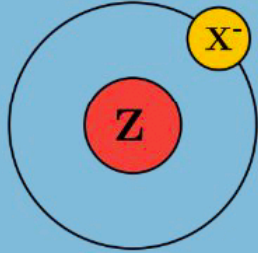

- **Ab Initio Approach:** based only on **Physical Laws** and **Fundamental Constants**.
- Supports **Normal, Exotic, or Mixed Atomic Systems**.
- Supported **Exotic Particles:**
  - $K^-$  : Kaons
  - $\mu^-$  : Muons
  - $\pi^-$  : Pions
  - $\Sigma^-$  : Sigmas
  - $\bar{p}^-$  : Antiprotons
  - $X^-$  : Test Particles

## MCDF Framework

### Basis Wavefunctions:

- Dirac Equation (spin-1/2 particles)

$$[c\boldsymbol{\alpha} \cdot \mathbf{p} + \beta mc^2 + V(\mathbf{r})] \psi_i(\mathbf{r}) = \varepsilon_i \psi_i(\mathbf{r})$$

- Klein-Gordon Equation (spin-0 particles)

$$[-\hbar^2 c^2 \nabla^2 + m^2 c^4] \phi(\mathbf{r}) = [E - V(\mathbf{r})]^2 \phi(\mathbf{r})$$

### Multi-Configuration Dirac-Fock:

$$\Psi = \sum_{v=1}^{NCF} W_v \phi^v(1, 2, \dots, N; J, J_z)$$

$$E_{\text{tot}} = \sum_{\nu\mu} W_\nu W_\mu \langle \phi^\nu | H | \phi^\mu \rangle / \sum_{\nu} W_\nu^2$$

### Total Energies Contributions:

- QED (All-Orders)
- Breit Interaction
- Recoil Effect
- Nuclear Finite Size
- Screening Effect

## Output Quantities

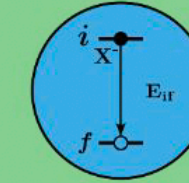

### Energy Levels & Transitions

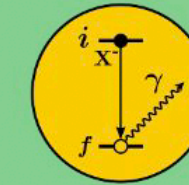

### Radiative Transition Probabilities

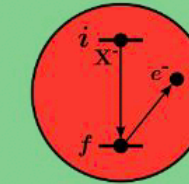

### Auger Decay Rates

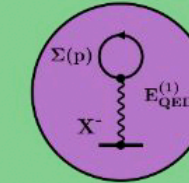

### QED Self-Energy & Vacuum Polarization

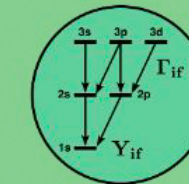

### Parameters for Atomic Cascade

# QED Studies: Charged Kaon Mass with KNe

$$M'_{K^-} = M_{K^-} \frac{E^{exp}}{E^{calc}} \quad \delta M_{K^-} = M_{K^-} \frac{\delta E^{exp}}{E^{exp}}$$

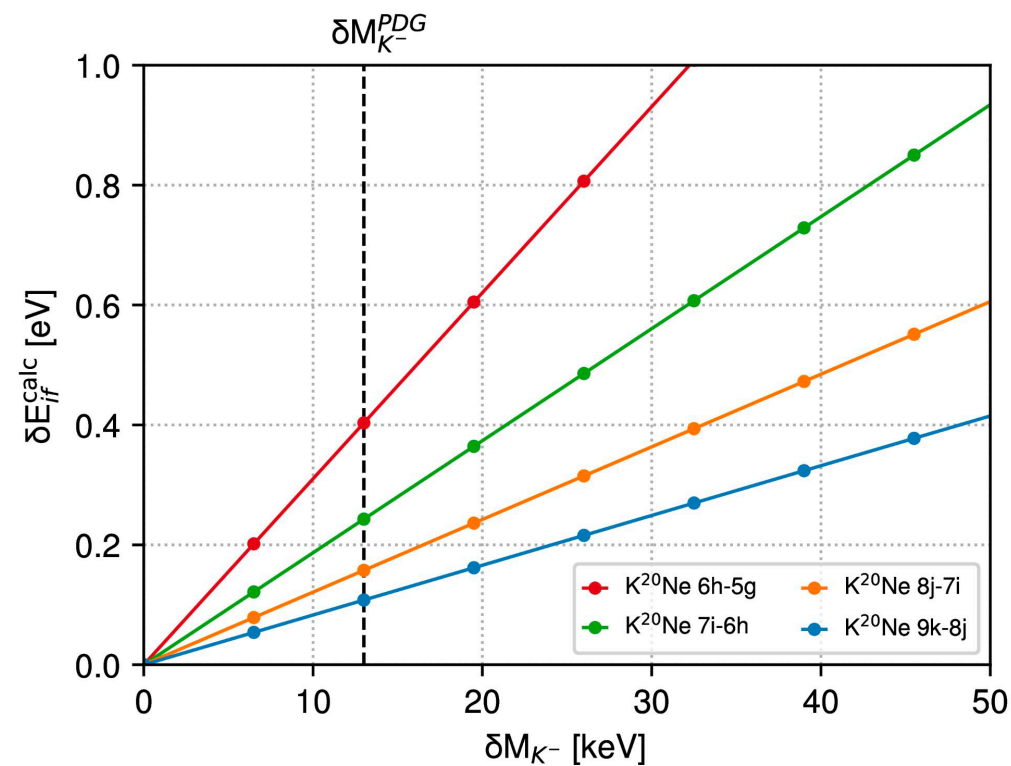

$$M_{K^-} = 493.677 \pm 0.018(stat) \pm 0.066(syst) \text{ MeV}$$

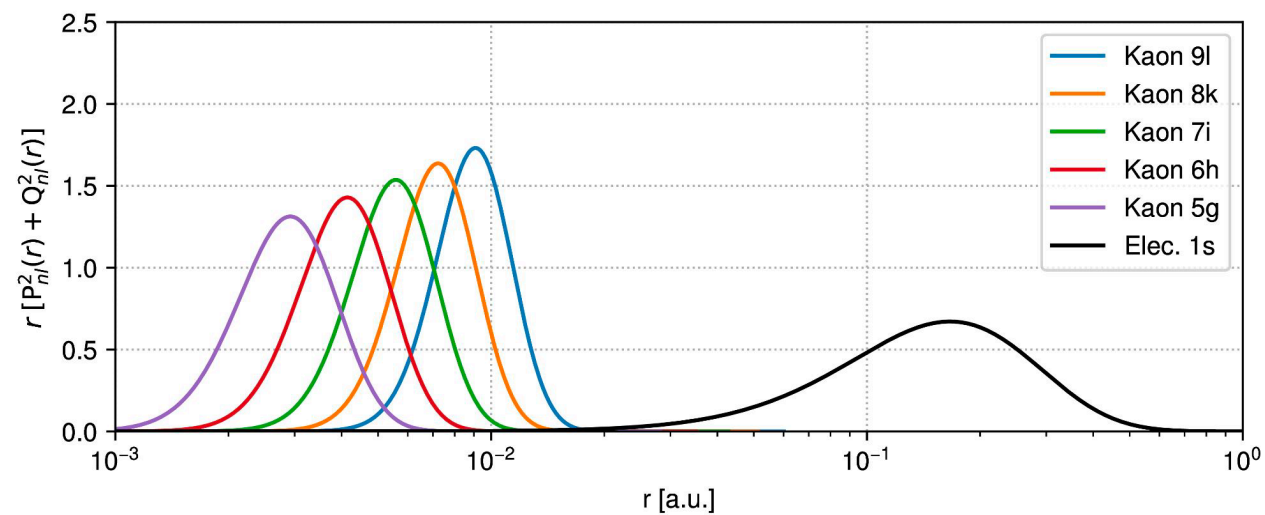
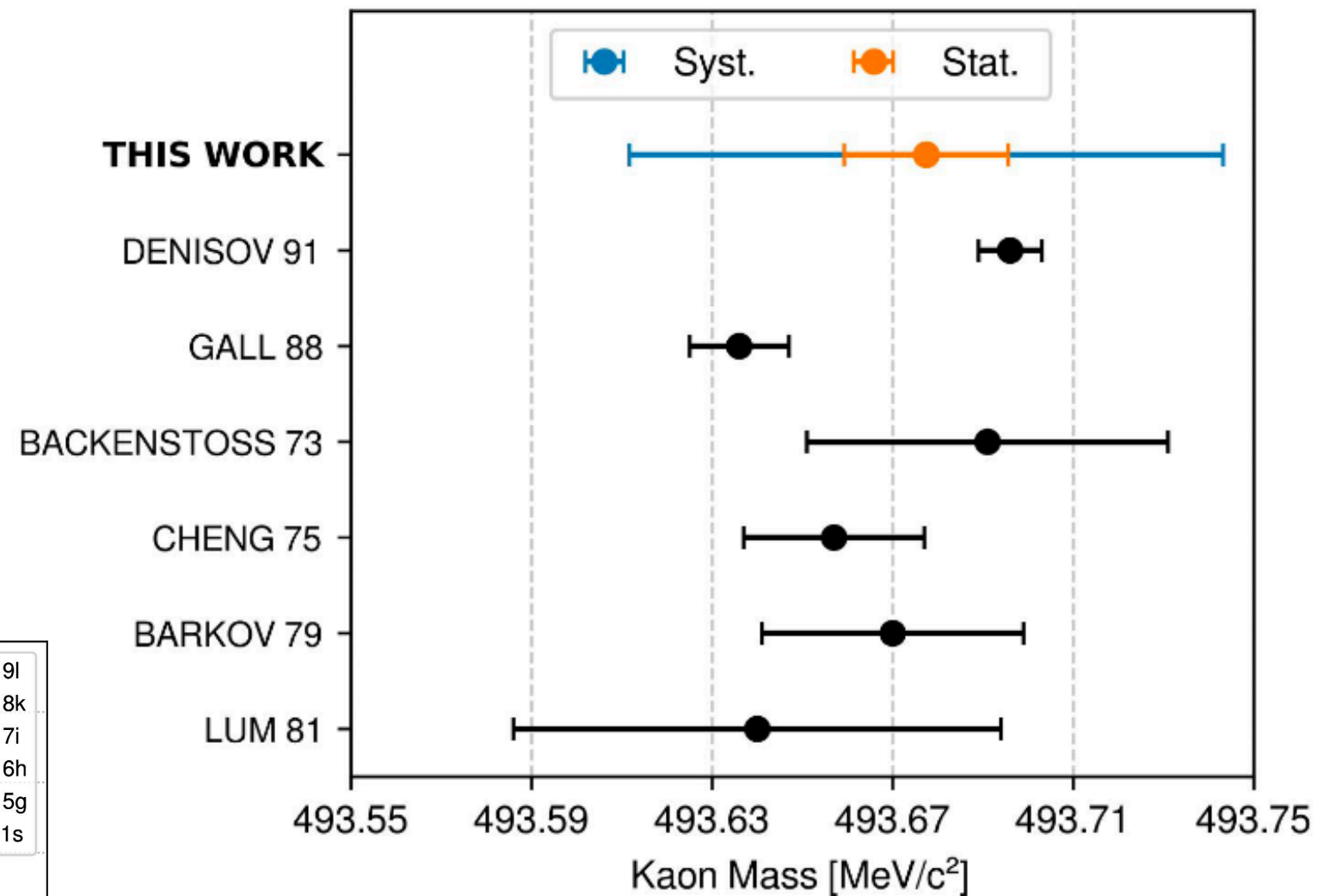

# QED Studies: BSM physics

Exotic atoms constrain new mediator mass and coupling [*Phys. Rev. Lett.* 135, 131803 (2025)]

$$E_n^{\text{th}} = \underbrace{E_n^{\text{SM-NPol}} + E_n^{\text{NPol}}}_{E_n^{\text{SM}}} + E_n^X$$

$$|E_{n,n-1}^X| = |E_{n,n-1}^{\text{exp}} - E_{n,n-1}^{\text{SM}}| < 2\sigma_{E_{n,n-1}^{\text{exp}}}$$

The spin-independent component of new interactions manifests as an effective Yukawa potential [82]

$$V_X(\mathbf{r}) = (-1)^s \frac{g_N^X g_H^X}{4\pi} \frac{e^{-m_X r}}{r}, \quad (4)$$

where  $X$  denotes the new boson with spin  $s$ .  $g_H^X$  ( $g_N^X$ ) represents the coupling to the hadron (nucleus). In a non-relativistic approximation, the first-order perturbation of this potential to the energies of circular states is

$$E_n^X = (-1)^s \frac{g_H^X g_N^X}{4\pi} \frac{1}{r_n} \frac{1}{\left(1 + \frac{m_X r_n}{2n}\right)^{2n}} \equiv g_H^X g_N^X h_n^X, \quad (5)$$

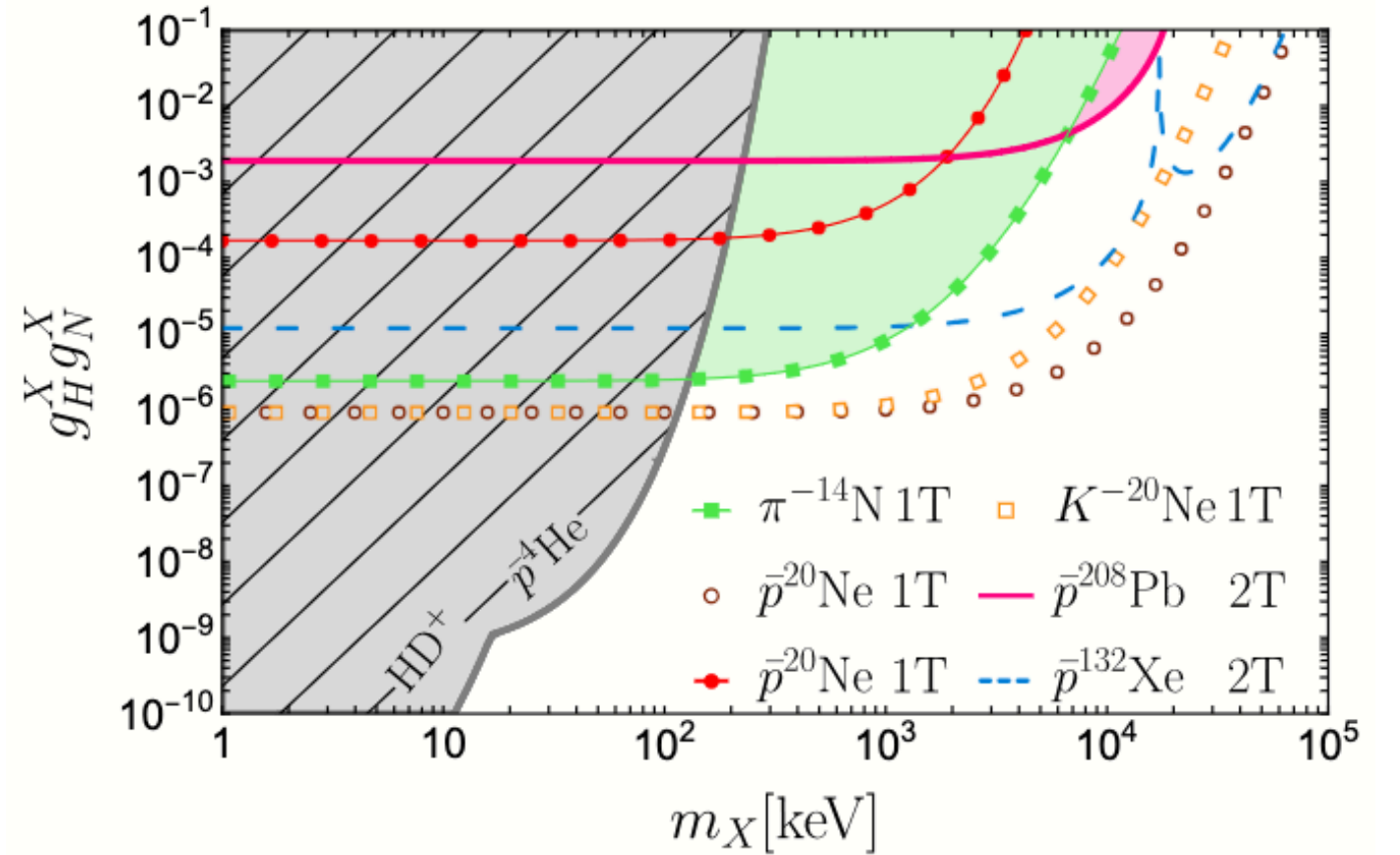

# Probing QED beyond the Schwinger Limit with KF

Transition	$E_{if}^{(exp.)}$	$\delta E_{if}^{(stat.)}$	$\delta E_{if}^{(sys.)}$	$E_{if}^{(calc.)}$	$E_{if}^{(QED)}$	$E_{if}^{(QED1)}$	$E_{if}^{(QED2)}$	FNS	PDG	Screen.	HFS
6h-5g	12673.9	5.9	7.1	12684.69	23.49	23.31	0.17	0.01	0.33	-0.09	0.27
7i-5g	20298.8	16.3	6.0	20327.49	32.26	32.02	0.24	0.01	0.52	-0.25	0.27
5g-4f	23383.2	4.7	5.5	23377.38	67.54	67.07	0.47	0.03	0.60	-0.04	0.87
8k-5g	25279.6	36.2	5.0	25285.56	35.65	35.38	0.27	0.01	0.65	-0.48	0.27
6h-4f	36073.3	30.7	30.0	36062.07	91.02	90.38	0.64	0.04	0.93	-0.13	0.87
4f-3d	50586.7	24.3	23.0	50590.48	222.99	221.45	1.54	0.13	1.30	0.01	4.16

Line	E_QED / E_if	E_QED / Tot.
6h-5g	0.18%	2.55
7i-5g	0.16%	1.86
5g-4f	0.29%	9.31
8k-5g	0.14%	0.98
6h-4f	0.25%	2.12
4f-3d	0.44%	6.64

Line	E_QED / E_if	E_QED / Tot.
9l-8k	0,05%	0,53
8k-7i	0,08%	3,11
7i-6h	0,13%	8,19
6h-5g	0,21%	3,63

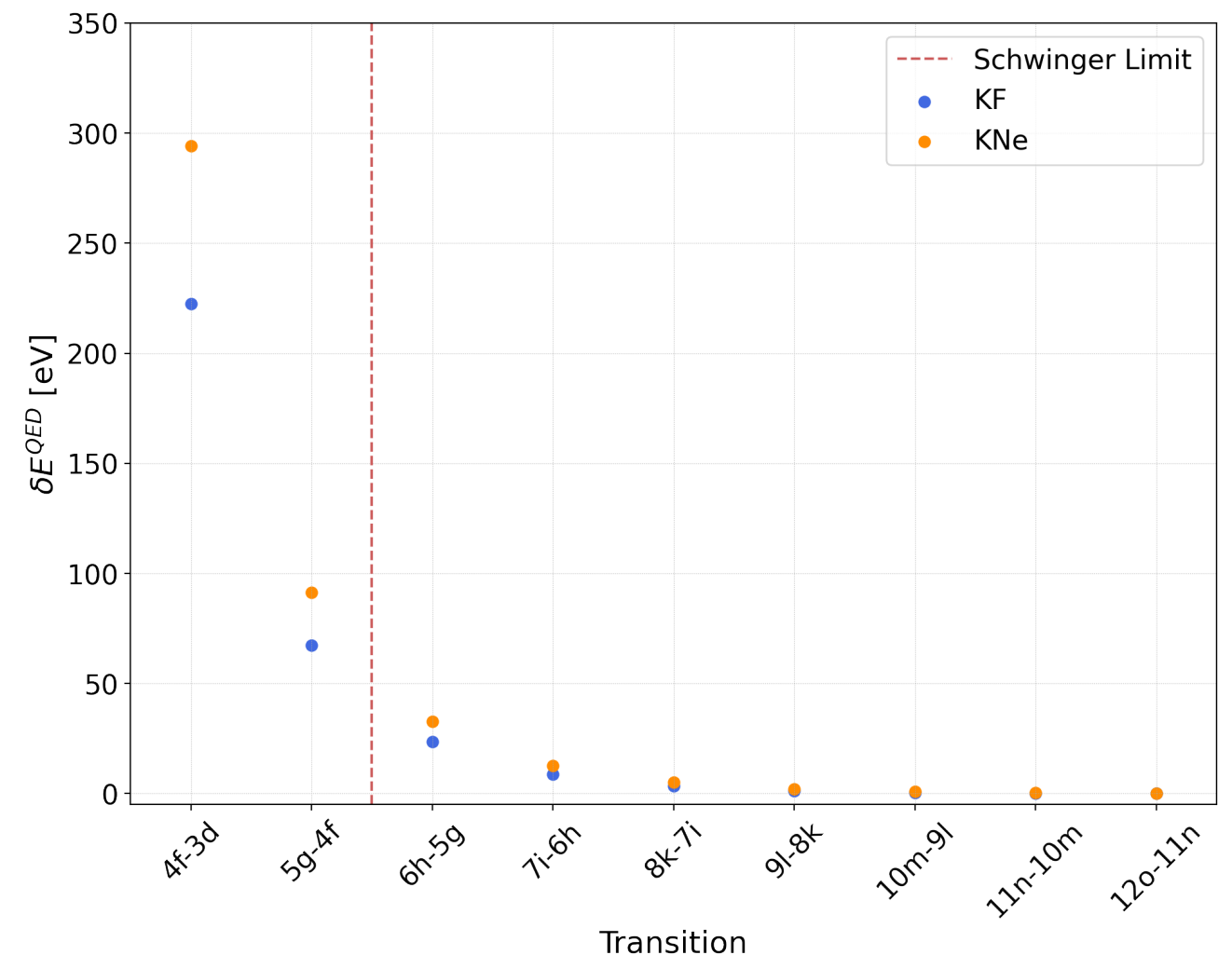

# Probing QED beyond the Schwinger Limit with KF

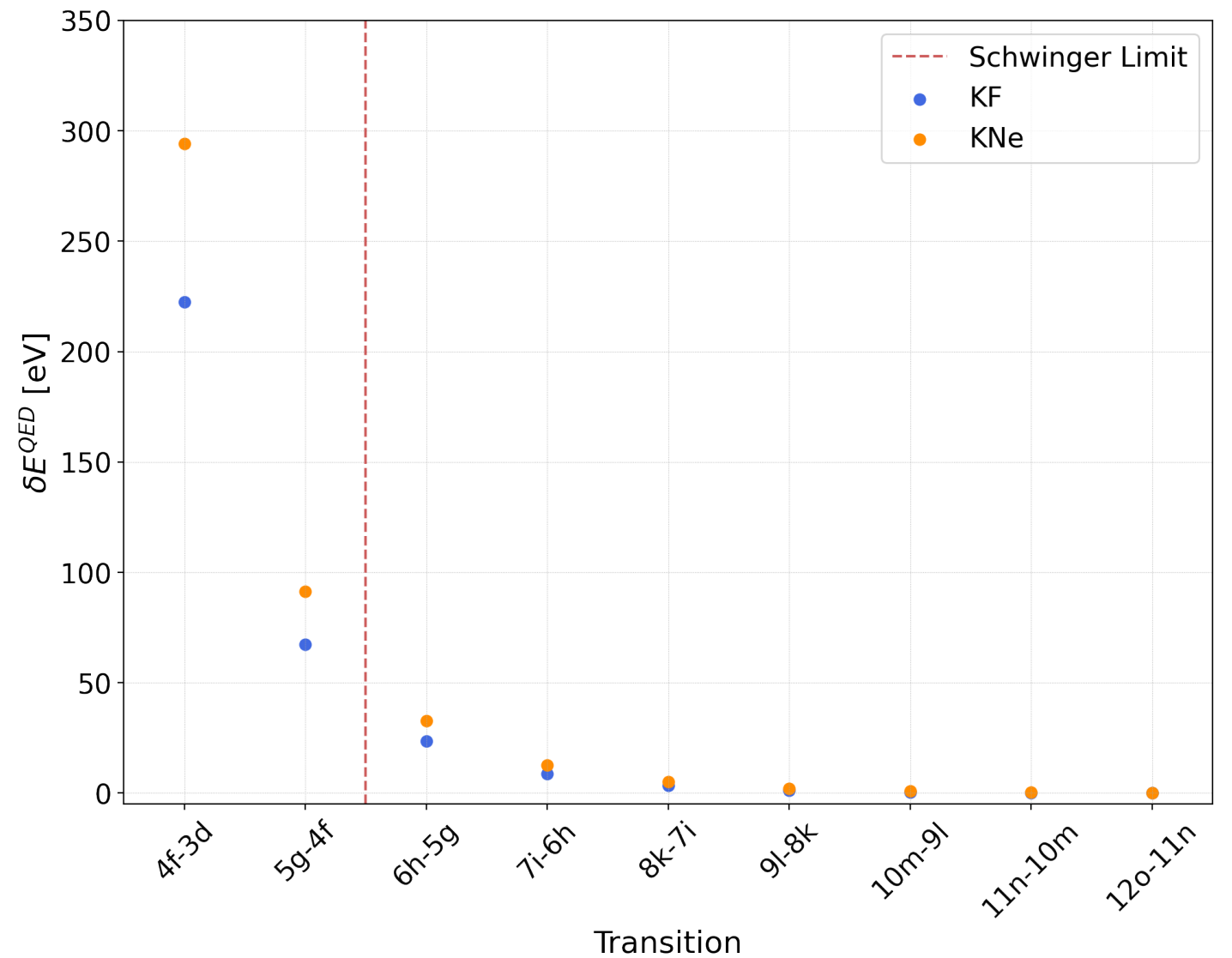
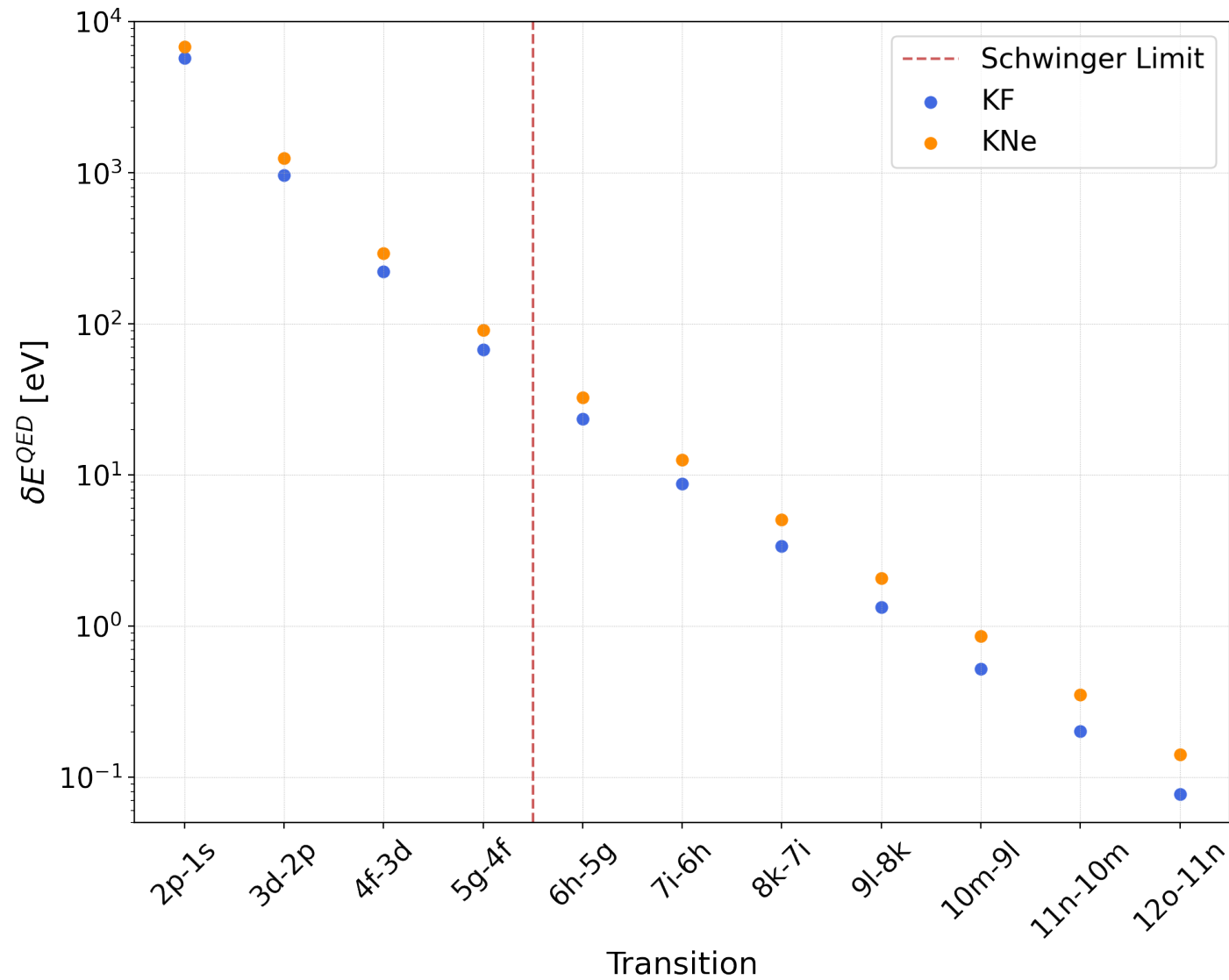

# Need of a Kaonic Deuterium measurement

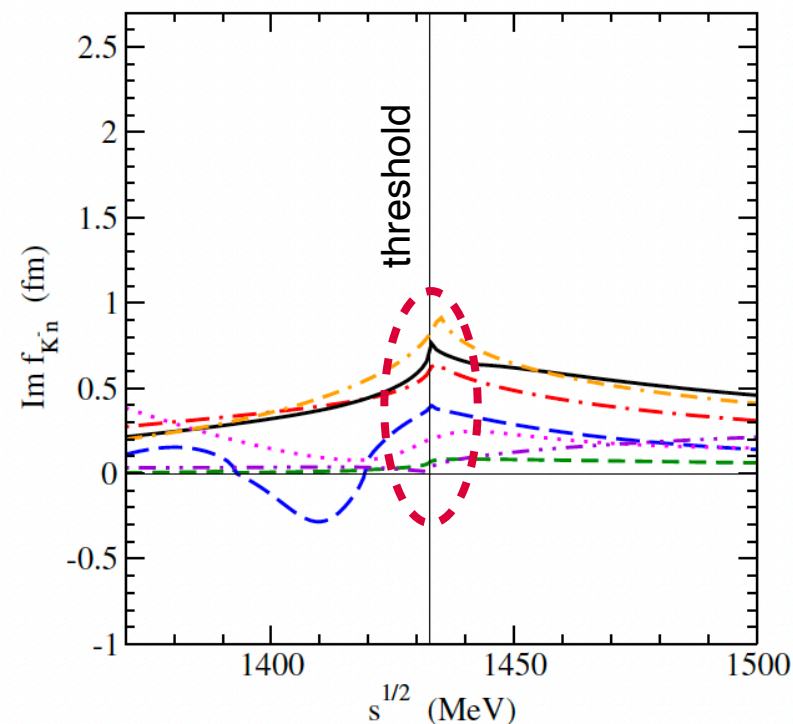
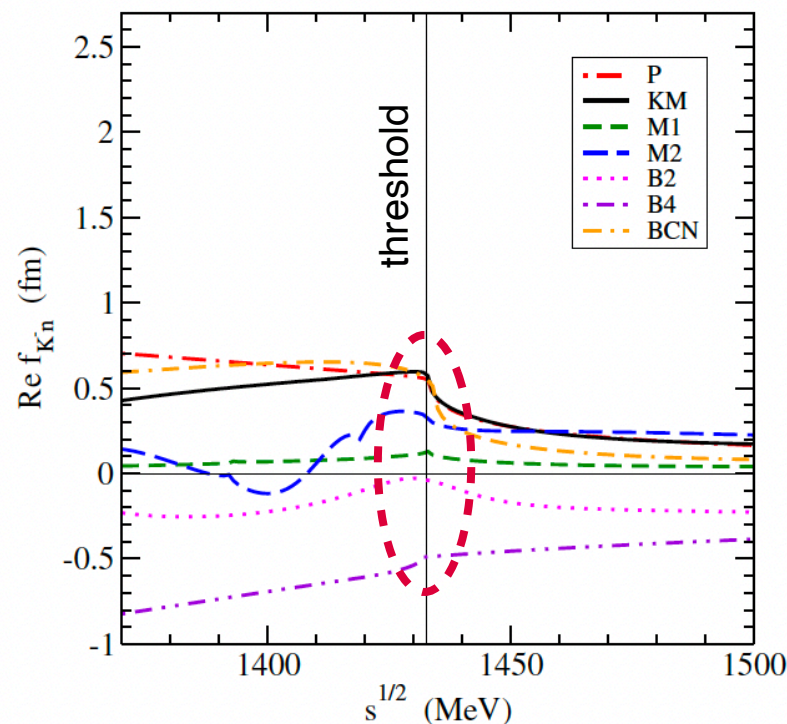
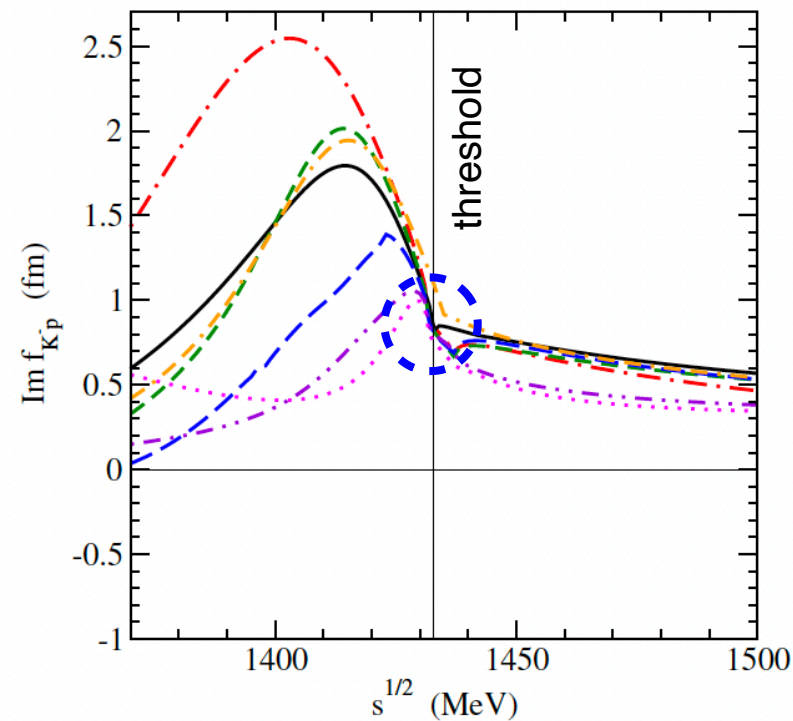
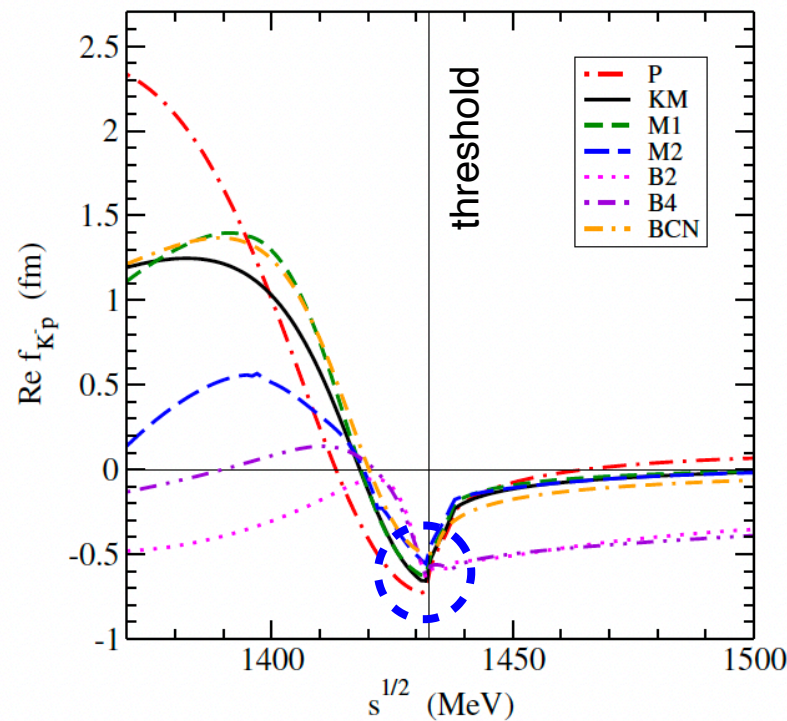

- Theoretical models in **good agreement**  $K^-p$  low momentum scattering amplitude
- Theoretical models for the  $K^-n$  low momentum scattering amplitude **highly spread**

Óbertová, J., Friedman, E., Mareš, J. & Ramos, À. On  $K$ -nuclear interaction,  $K$ -nuclear quasibound states and  $K$ -atoms. In *EPJ Web of Conferences*, vol. 271, 07003 (EDP Sciences, 2022).

# Physics of light kaonic atoms

- Antikaon-nucleon **scattering lengths** ( $a_{\bar{K}N}$ ) related to these observables

$$\epsilon_{1s}^H + \frac{i}{2}\Gamma_{1s}^H = 2\alpha^3 \mu^2 a_{\bar{K}p} \left[ 1 - 2\alpha\mu(\ln\alpha - 1)a_{\bar{K}p} + \dots \right]$$

fine structure constant
reduced mass

Meißner, U.-G., Raha, U. & Rusetsky, A. Spectrum and decays of kaonic hydrogen. *The European Physical Journal C-Particles and Fields* 35, 349–357 (2004).

$$\lim_{k \rightarrow 0} \sigma_e = 4\pi a^2$$

Landau, L. D. & Lifshitz, E. M. *Quantum Mechanics: non-relativistic theory, vol. 3* (Elsevier, 2013).

elastic cross section

- Combined analysis of kaonic hydrogen and kaonic deuterium to extract the isospin-dependent antikaon-nucleon scattering lengths
- Kaonic hydrogen measured by the SIDDHARTA experiment in 2009
- **Lack of a kaonic deuterium measurement**

# The SIDDHARTA-2 apparatus: kaon trigger

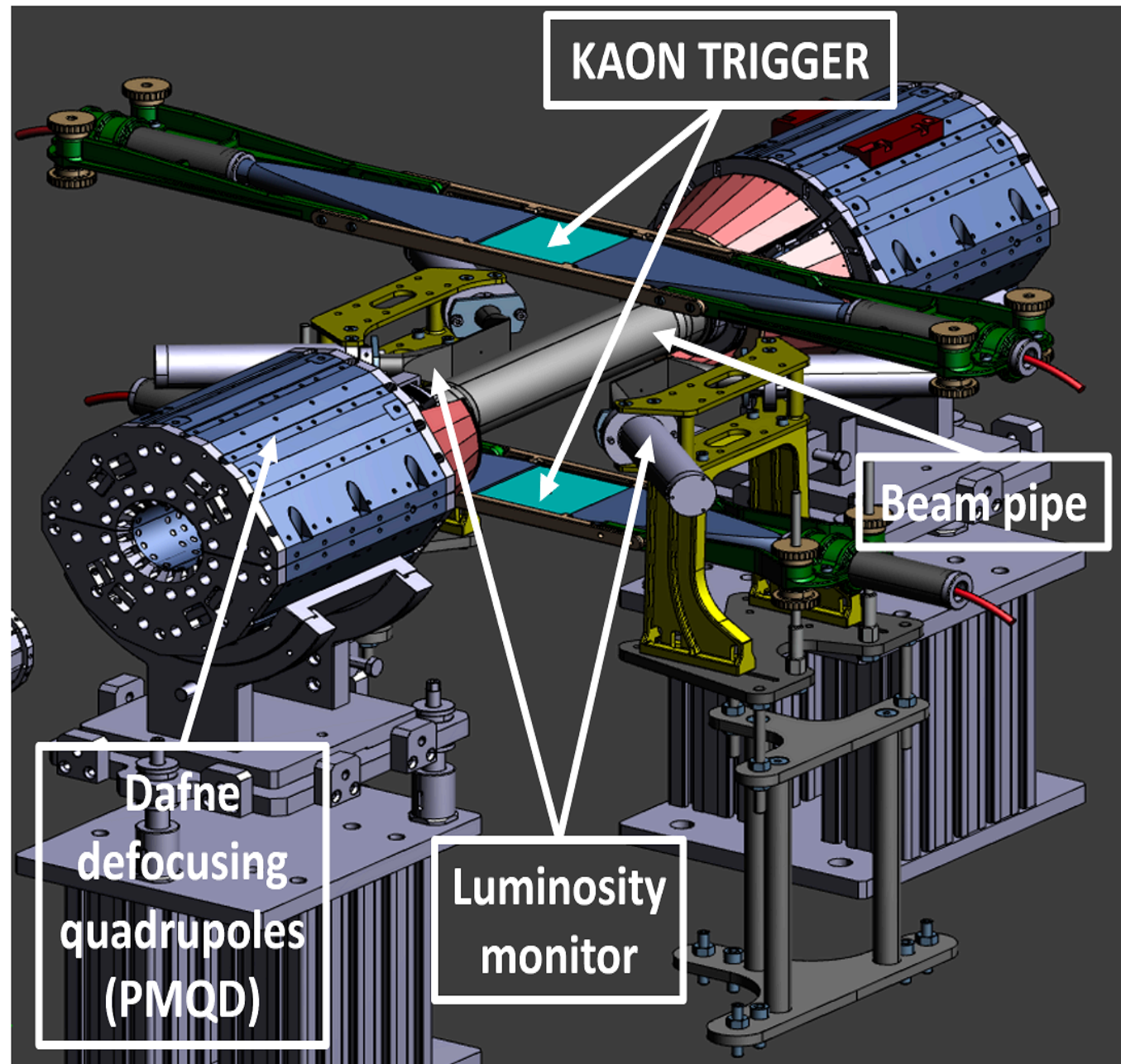

- Pair of **plastic scintillators** above and below the IP
- Read by two PMTs each
- Selection of kaons as coincidence between the scintillators (5  $\mu\text{s}$  time window)
- **Suppression of asynchronous background** related to particle losses from  $e^+e^-$  beams due to Touschek effect
- MIPs-induced triggers suppressed with Time-of-Flight ToF signatures
- ToF referenced to DAΦNE RF (368MHz)

# The SIDDHARTA-2 Silicon Drift Detectors

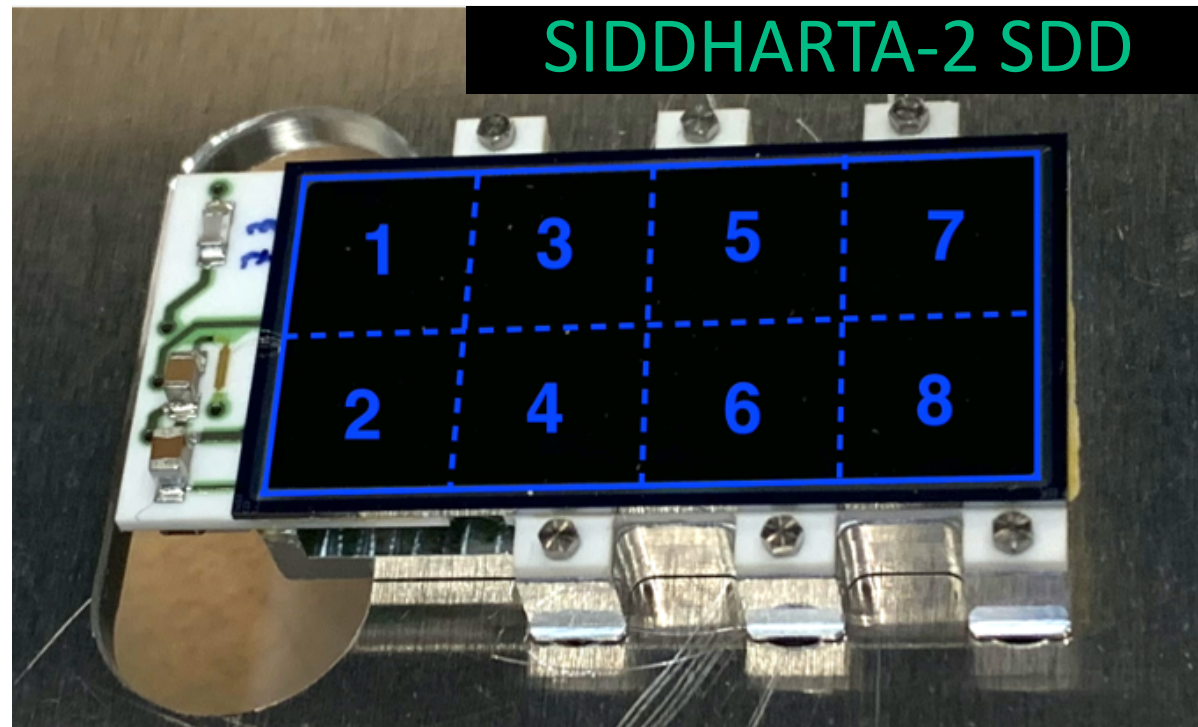

- SDD cells:  $8 \times 8 \text{mm}^2$  active area
- $450 \mu\text{m}$  thick silicon bulk: it allows a  $\sim 100\%$  detection efficiency for  $5\text{-}12 \text{keV}$  X-rays ( $\sim 7 \text{keV}$  region of interest for kaonic deuterium)
- Extremely good linear behaviour and energy resolution in the range of interest
- $\Delta E/E < 10^{-3}$
- FWHM  $\sim 170 \text{ eV}$  @  $6.4 \text{ keV}$

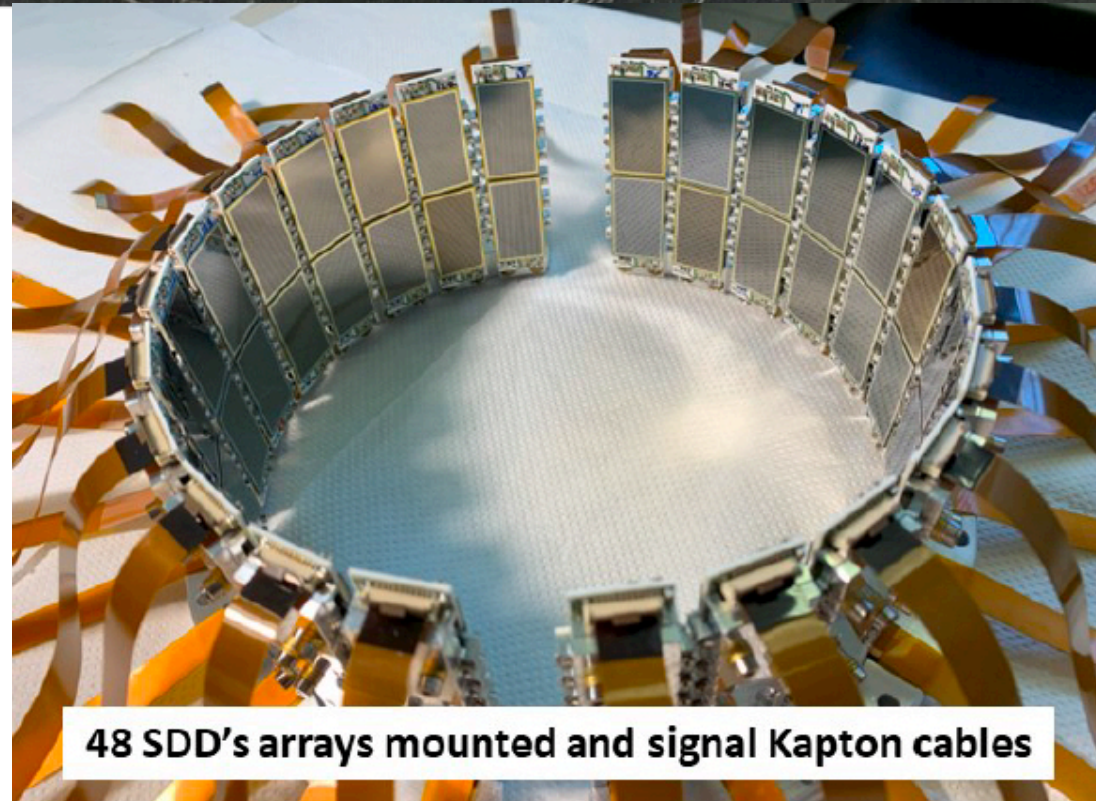

# New 1mm Silicon Drift Detectors

1mm SDD prototype

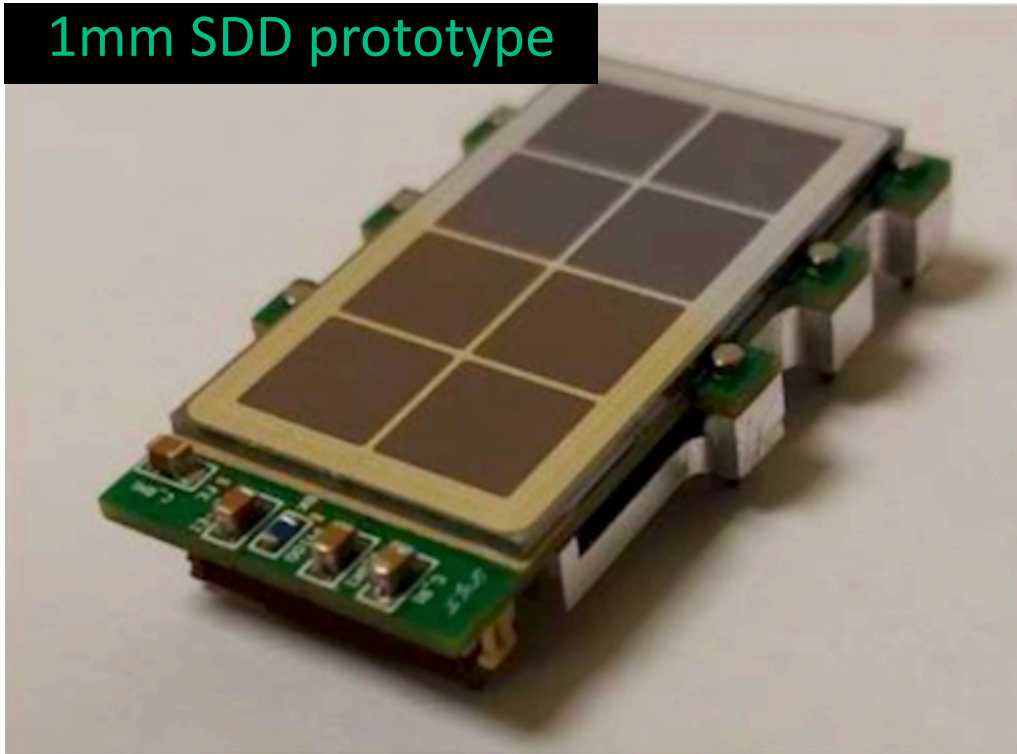

- Thicker silicon bulk will allow for a **much better efficiency at higher energy** (above 15 keV)
- Insight into the  $K^- - NN$  strong interaction

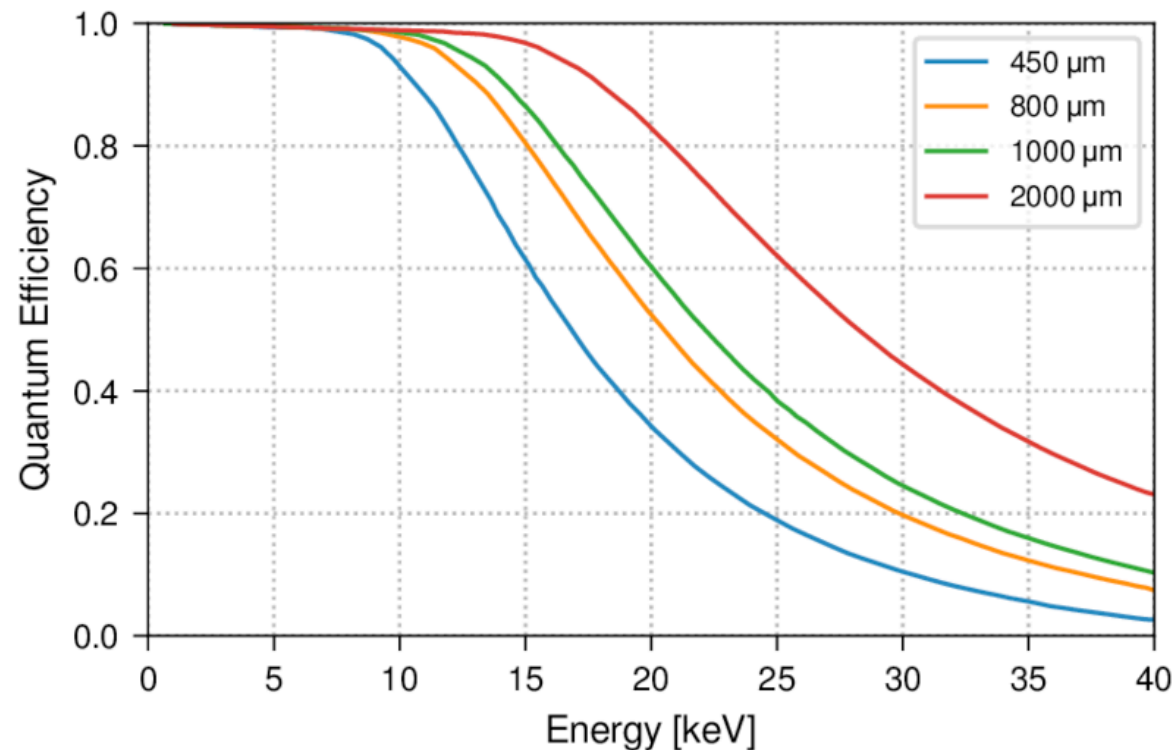

Lithium-6		Lithium-7		Beryllium-9	
Transition	Energy (keV)	Transition	Energy (keV)	Transition	Energy (keV)
<b>3 → 2</b>	<b>15.085</b>	<b>3 → 2</b>	<b>15.261</b>	<b>3 → 2</b>	<b>27.560</b>
4 → 2	20.365	4 → 2	20.603	4 → 3	9.646
<b>5 → 2</b>	<b>22.809</b>	<b>5 → 2</b>	<b>23.075</b>	5 → 3	14.111
4 → 3	5.280	4 → 3	5.341	5 → 4	4.465
5 → 3	7.724	5 → 3	7.814	6 → 4	6.890
5 → 4	2.444	5 → 4	2.472	6 → 5	2.425
6 → 4	3.771	6 → 4	3.815		

# The SIDDHARTA-2 apparatus: mylar degrader

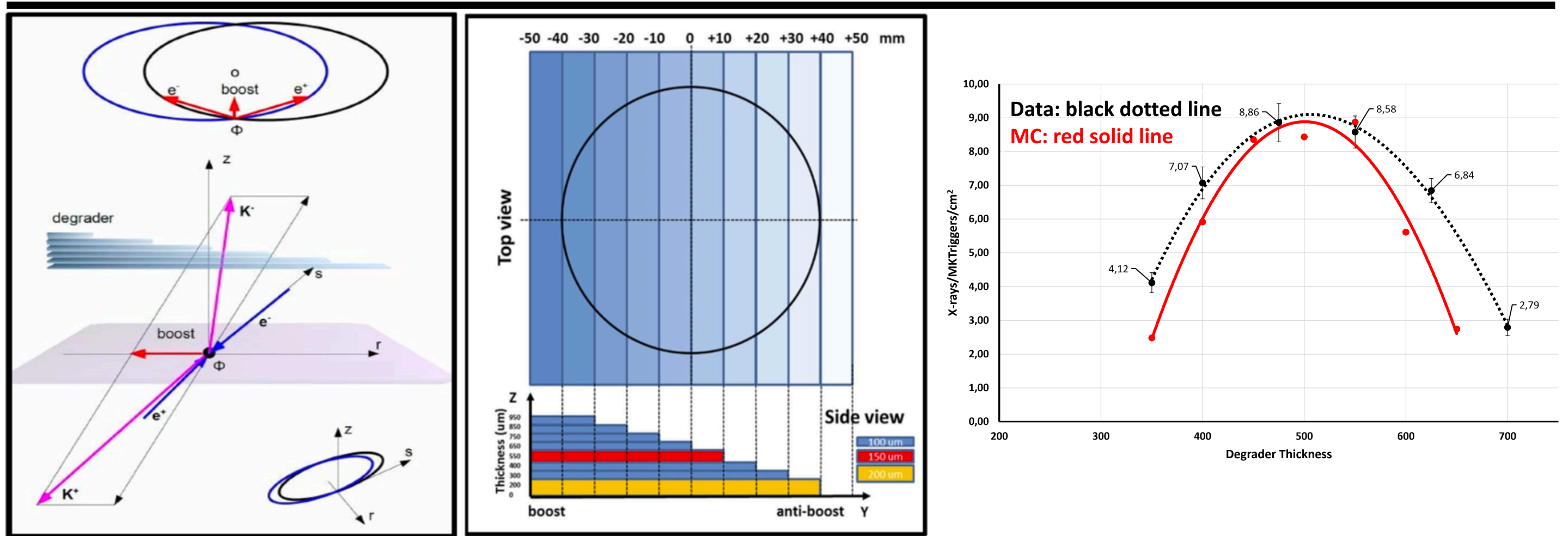

- **Maximization of kaons stopped** inside the target
- **Boost of the kaons** towards the center of the collider
- **Step-wise** mylar degrader to obtain a **uniform stopping distribution** inside the target
- Overall thickness ranges from 200 $\mu\text{m}$ -950 $\mu\text{m}$
- MC simulations + Experimental fine tuning to optimise the shape and thickness