

Test of QED in molecular hydrogen

1. Dissociation/ionization energy
2. Vibrational Quadrupole transition

Benchmark: H₂ Dissociation energy

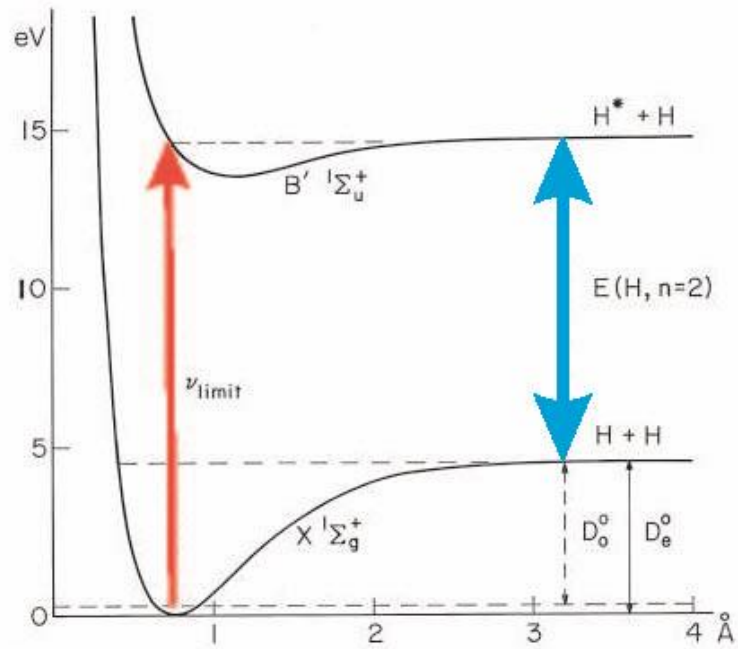

Direct Method
Measurement of n=2 onset

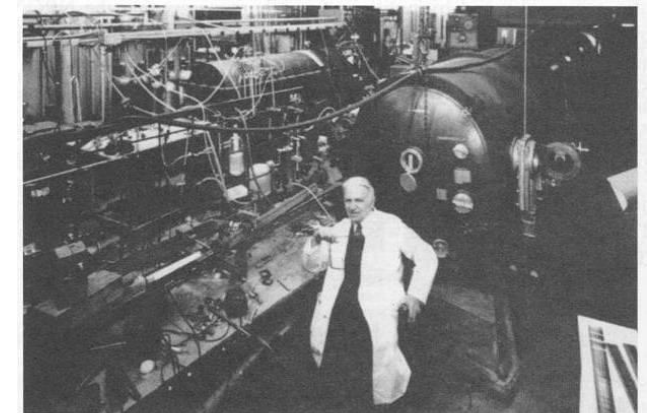
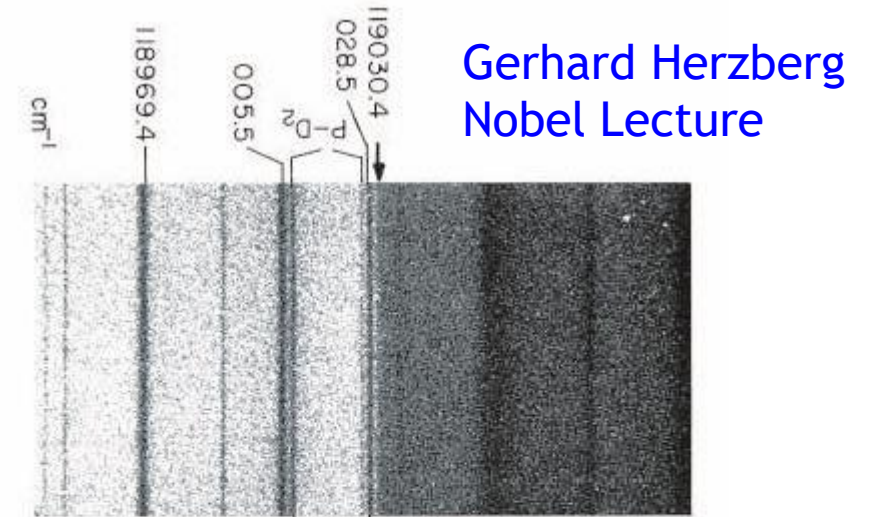

Herzberg in his laboratory.

H₂ Ionization energy better target

vibrational interlopers

267

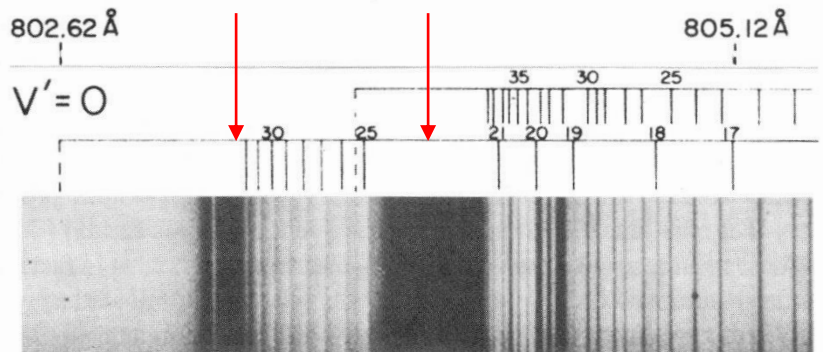

Absorption spectrum of para-H₂ showing two Rydberg series, going to two different limits, after Herzberg and Jungen, 1972.

$N^+=2$ $N^+=0$

Herzberg and Jungen 1972
Birth of MQDT for molecules



Christian Jungen

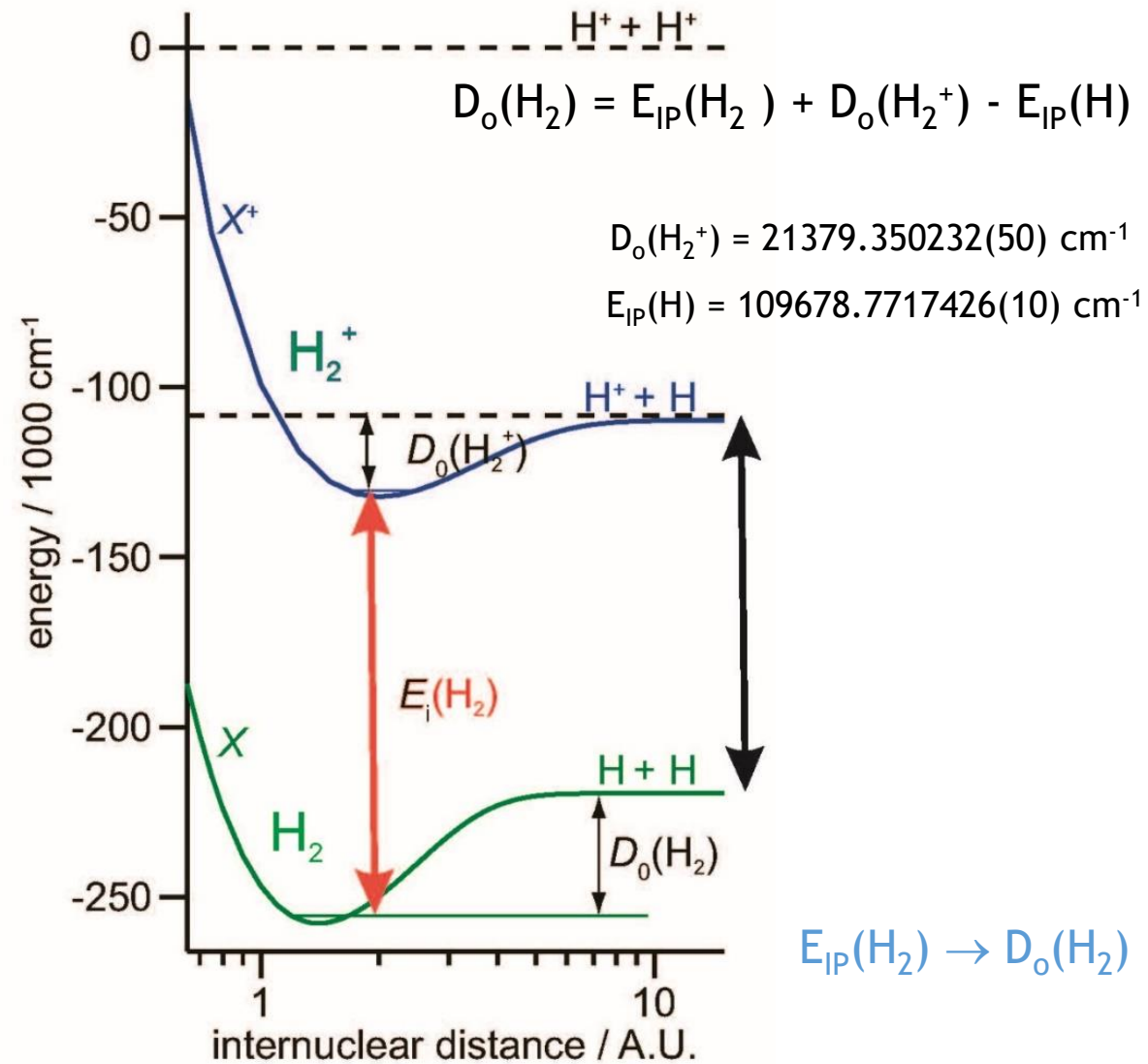

Early approaches to our IP/D₀ work in H₂ / HD

PHYSICAL REVIEW A, VOLUME 65, 064501

Spectroscopy on some *g* symmetry states in H₂ and determination of the ionization potential

A. de Lange, E. Reinhold, and W. Ubachs

Laser Centre, Vrije Universiteit, De Boelelaan 1081, 1081 HV Amsterdam, The Netherlands

(Received 18 December 2001; published 3 June 2002)

Multi-step excitation

IP (H₂) = 124417.476 (12) cm⁻¹

Accuracy ~ 3.5 GHz

High-resolution VUV photoionization spectroscopy of HD between the X ²Σ_g⁺ ν⁺ = 0 and ν⁺ = 1 thresholds†

G. M. Greetham,^a U. Hollenstein,^a R. Seiler,^a W. Ubachs^b and F. Merkt^{*a}

Phys. Chem. Chem. Phys., 2003, **5**, 2528–2534

One-step narrowband XUV

IP (HD) = 124 568.491 (17) cm⁻¹

Accuracy ~ 5 GHz

→ Amsterdam-Zürich collaboration

Dedicated program: Measurement of IP in H₂

3 step approach (Zürich-Amsterdam collaboration)

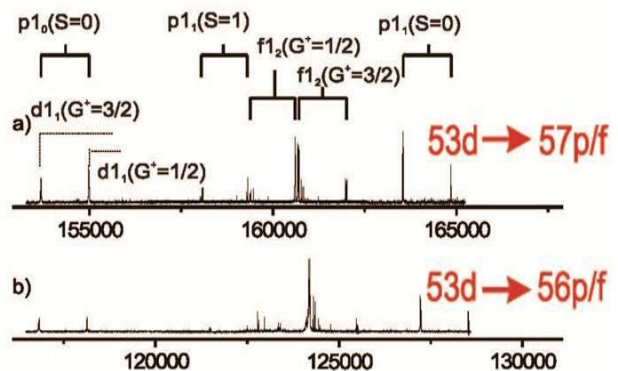
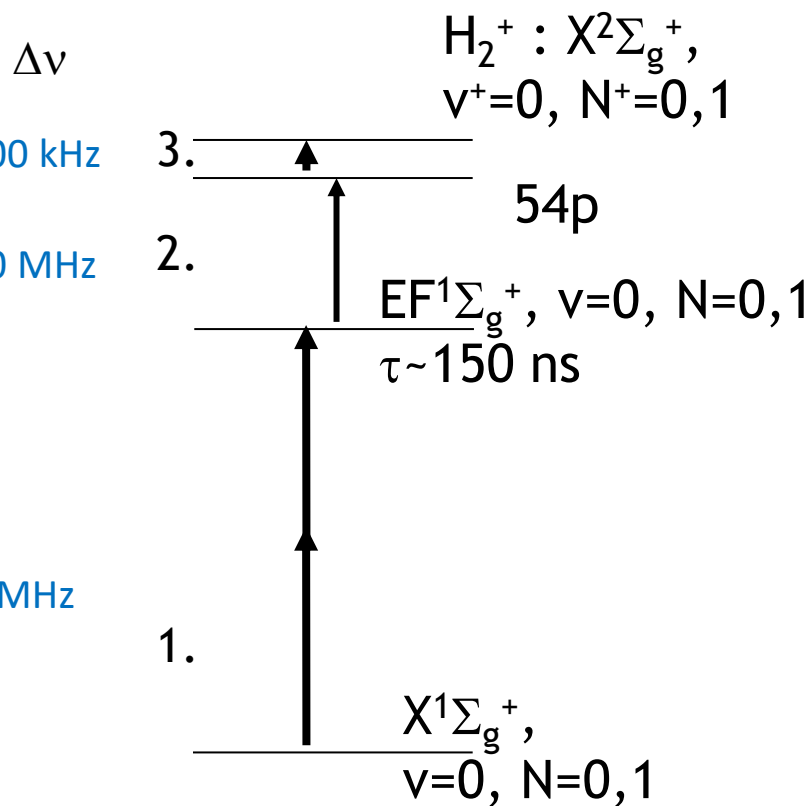

MM waves
Osterwalder, Jungen, Merkt
MQDT in H₂ with hyperfine

Limiting
One-photon
np - EF

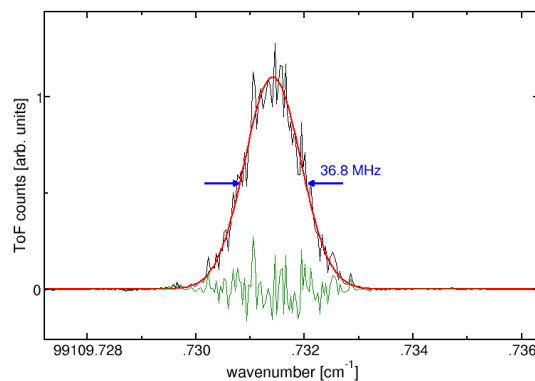
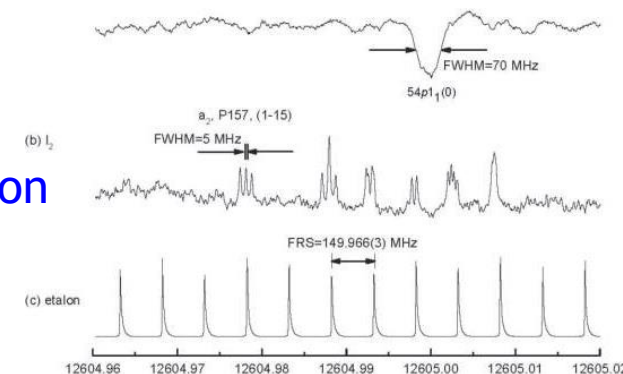

Two-photon
Doppler-free
EF-X

$$E_i \text{ (ortho)} = 124\,357.237\,97 \text{ (36)} \text{ cm}^{-1}$$

$$E_i \text{ (para)} = 124\,417.491\,13 \text{ (37)} \text{ cm}^{-1}$$

Theoretical Determination of the Dissociation Energy of Molecular Hydrogen

Konrad Piszczatowski,[†] Grzegorz Łach,^{†,||} Michał Przybytek,^{†,‡} Jacek Komasa,[¶]
Krzysztof Pachucki,[§] and Bogumił Jeziorski^{*,†}

JTCT. 5, 3039 (2009)

Comparison Theory/Experiment

$D_0(\text{H}_2)$: Experiment [1] 36118.0696(4) cm⁻¹

Theory [2]:

Born–Oppenheimer 36112.5927(1) cm⁻¹

adiabatic + 5.7711(1) cm⁻¹

nonadiabatic + 0.4339(2) cm⁻¹

total α^0 36118.7978(2) cm⁻¹

α^2 all relativistic - 0.5319(5) cm⁻¹

α^3 all QED - 0.1948(3) cm⁻¹

α^4 one-loop term - 0.0016(8) cm⁻¹

Total theory 36118.0695(10) cm⁻¹

QED

$D_0(\text{D}_2)$: Total theory [2] 36748.3633(9) cm⁻¹

Experiment [4] 36748.3629(7) cm⁻¹

Towards measuring the ionisation and dissociation energies of molecular hydrogen with sub-MHz accuracy

Faraday Meeting 2011

Daniel Sprecher,^a Christian Jungen,^{†b} Wim Ubachs^c and Frédéric Merkt^{*a}



Frédéric Merkt

III
Further refined MQDT analyses extrapolating

Time domain Ramsey comb



Kjeld Eikema

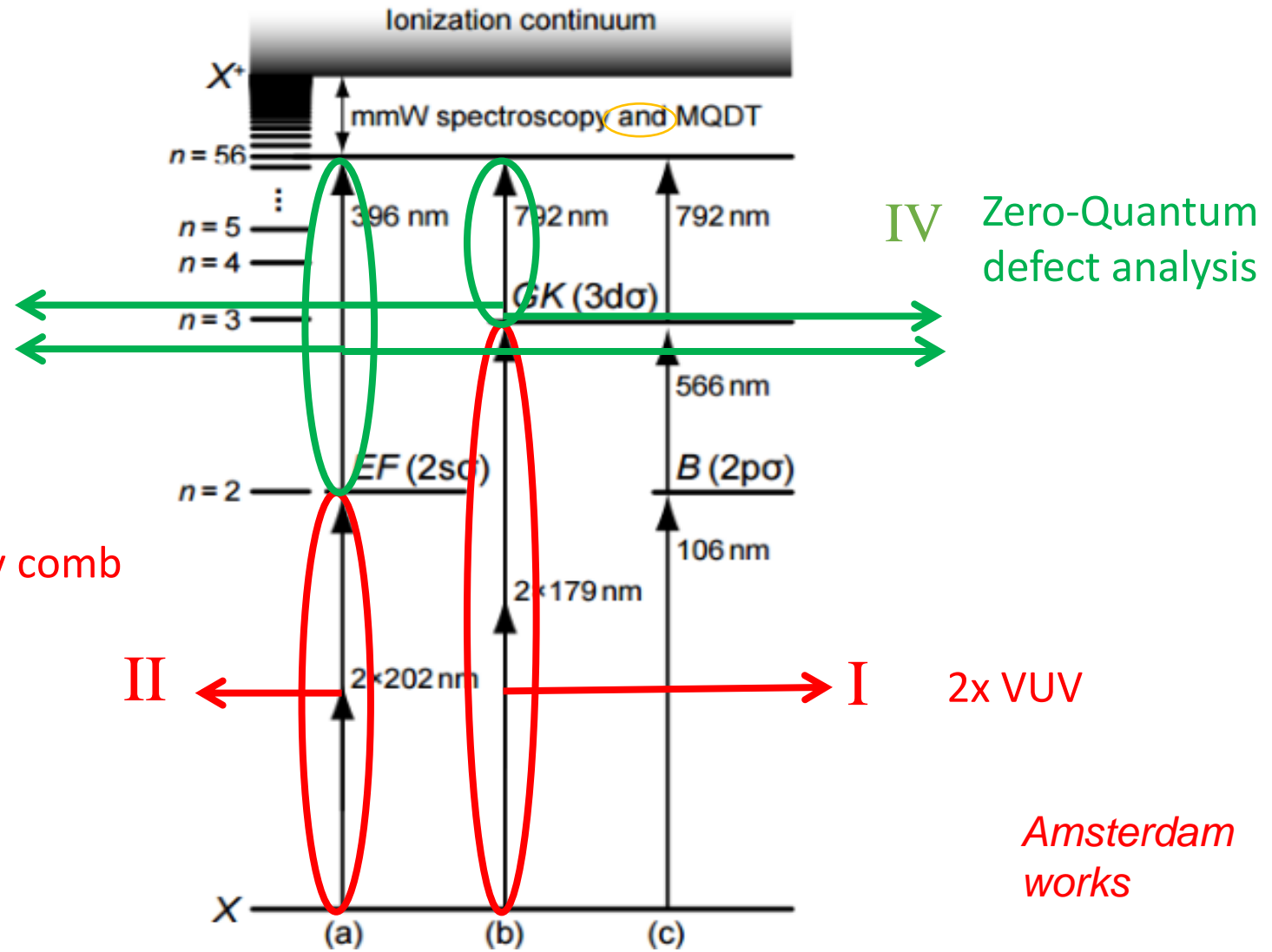



2-photon VUV Doppler-free Anti-chirped Ti:Sa long pulse

Amsterdam
works
2-photon
Doppler-free VUV



Joel Hussels
AMS - PhD

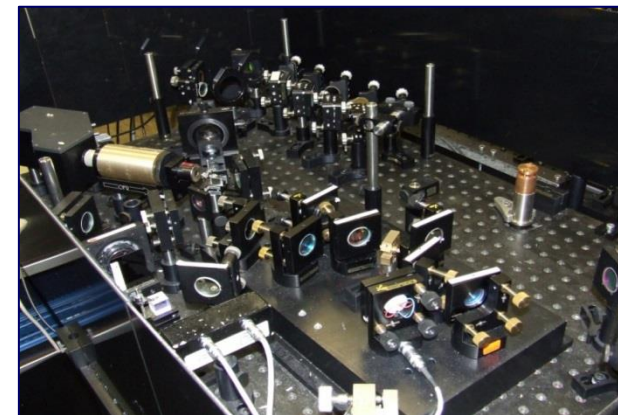
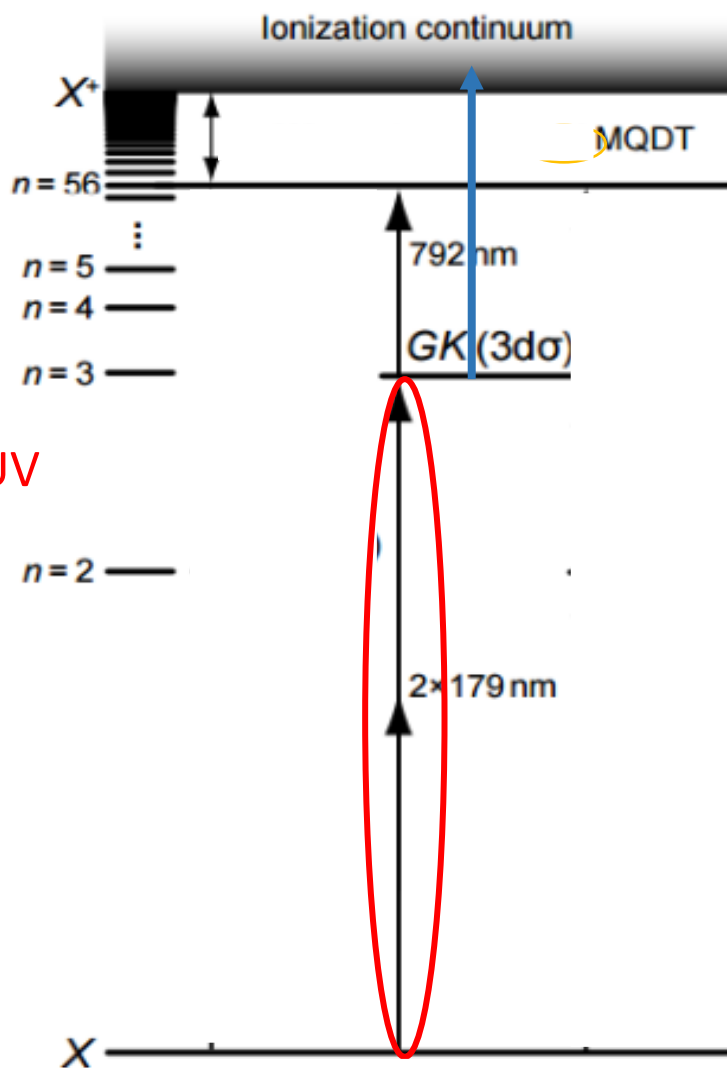

Home-built long-pulse narrowband
Ti:Sa laser @ 716 nm; locked to comb

KBBF crystal for doubling
to 179 nm

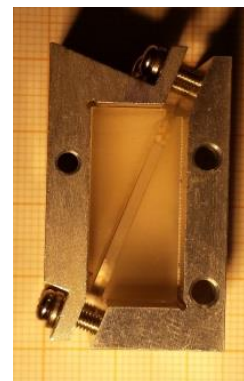

VUV mirror for
Retroreflection
In Vacuum

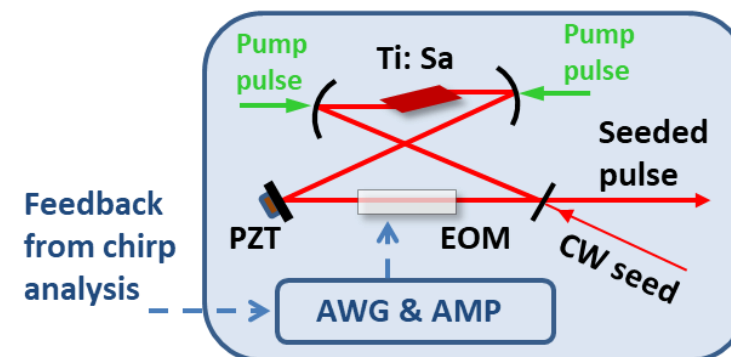

Anti-chirped Ti:Sa pulsed oscillator

Opt. Lett. 45, 5909 (2020)

Zürich results – to IP

III: zero field measurements

IV: zero QD measurements; Stark field

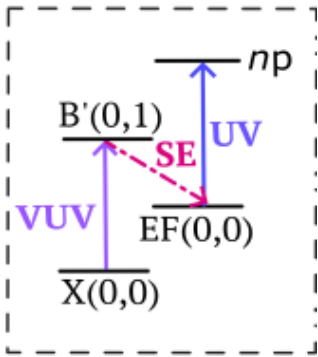

Ion-free preparation

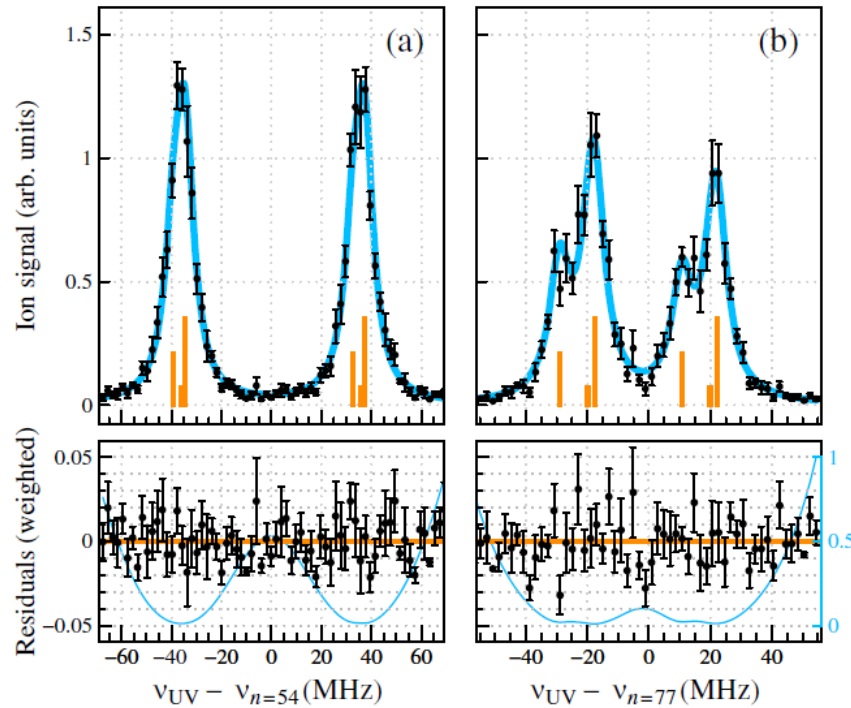

CW UV-laser excitation of Rydberg States; EF- np
+MQDT analysis extrapolation

N. Hoelsch, et al.
Phys. Rev. Lett. 122, 103002 (2019)

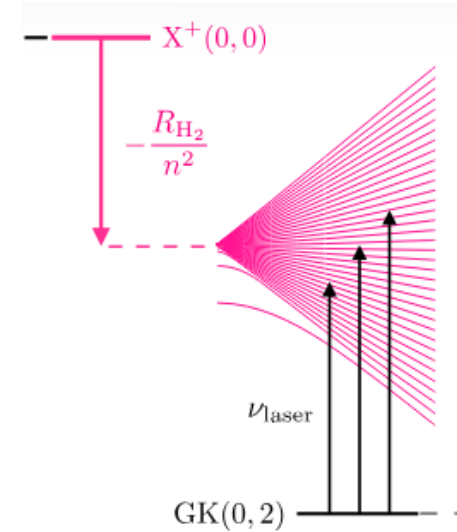

Ioana Doran
ETHZ

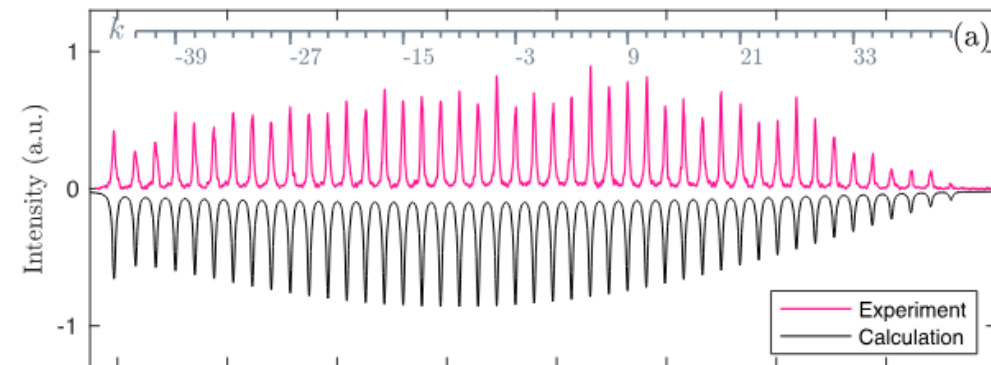

I. Doran, N. Hoelsch, M. Beyer, F. Merkt
Phys. Rev. Lett. 132, 073001 (2024)

Comprehensive analysis of all paths into a spectral network

I, II, and III, IV and para/ortho

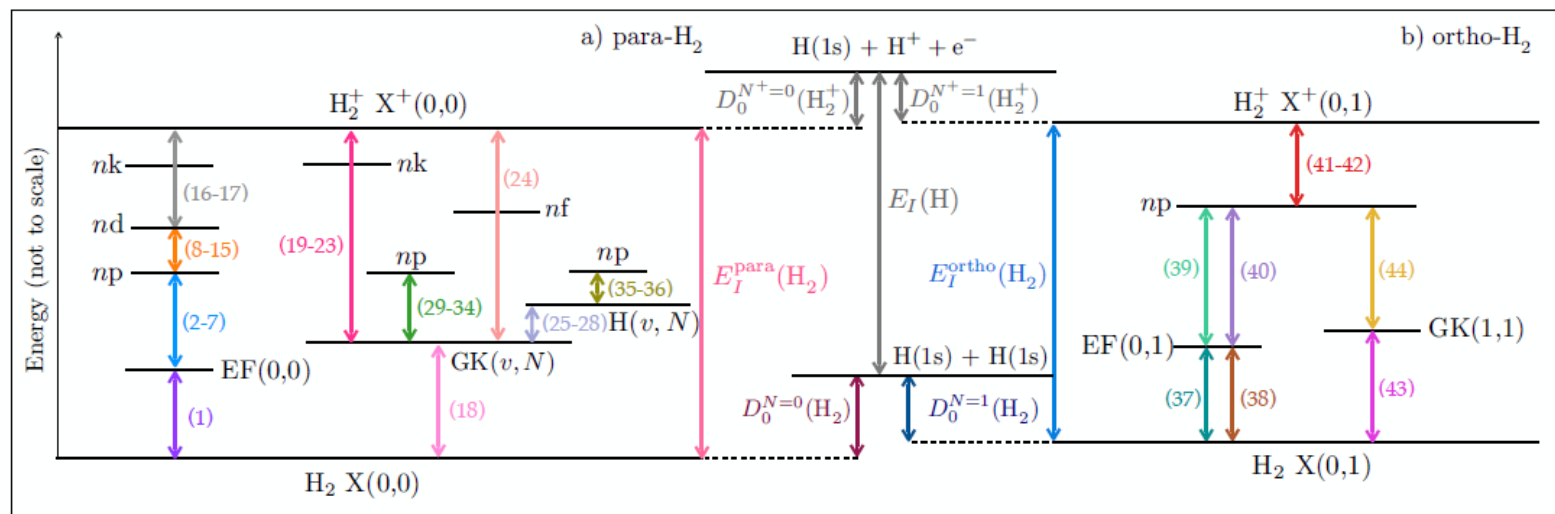

Results: Preliminary

$$D_0(N=0) = 36\,118.069\,663\,8\, (58) \text{ cm}^{-1}$$

180 kHz

$$D_0(N=1) = 35\,999.582\,843\, (16) \text{ cm}^{-1}$$

480 kHz

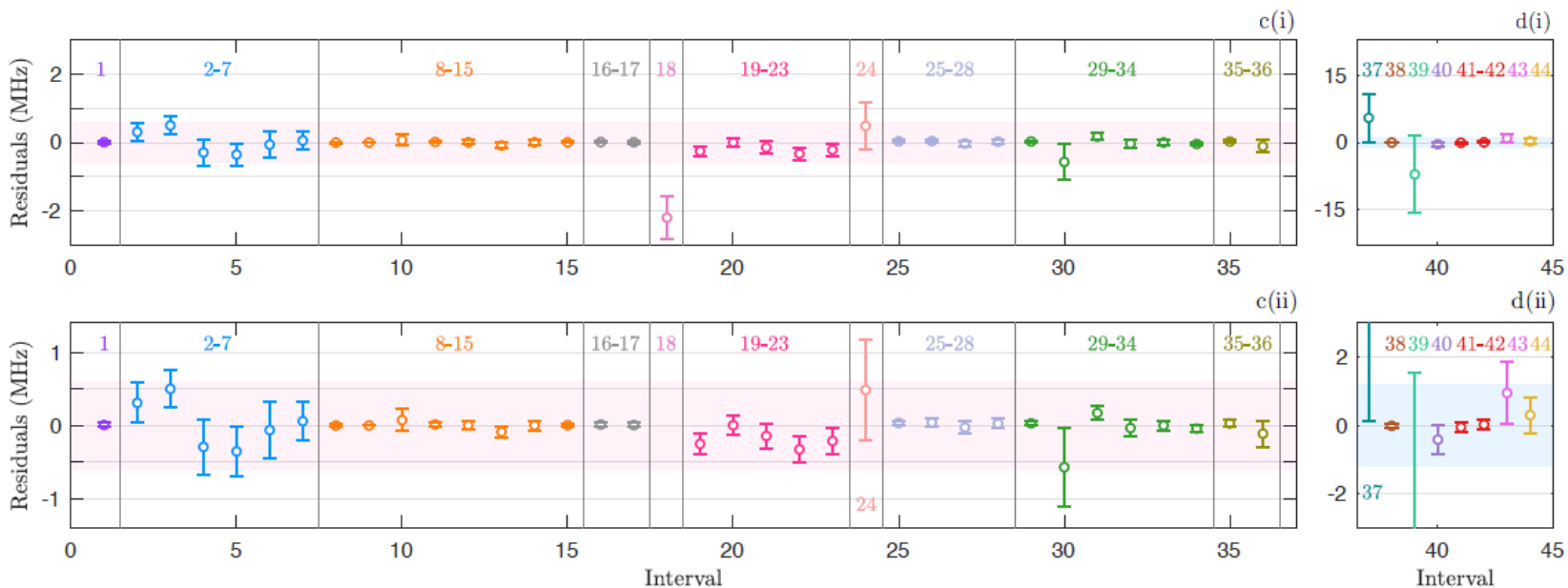

Theory (state-of-the-art):

$$D_0(N=0) = 36118.069\,630\, (26) \text{ cm}^{-1}$$

$$D_0(N=1) = 35999.582\,816\, (26) \text{ cm}^{-1}$$

780 kHz uncertainty

Pachucki and Komasa
JTCT 21, 12664 (2025)

Improvements on theory (2010-2025)

NRQED



Krzysztof
Pachucki

Jacek
Komasa

Mariusz
Puchalski

Series expansion in $m\alpha^n$

$$E(\alpha) = \sum_{n=2} m\alpha^n E^{(n)}.$$

Non-relativistic $E^{(2)}$

*Full 4-particle non-relativistic variational
30 digit accuracy*

Relativistic, Breit-Pauli $E^{(4)}$

$$\begin{aligned} H_{\text{rel}} = & -\frac{1}{8}(p_2^4 + p_3^4) + \frac{\pi}{2} \sum_{x,a} \left(1 + \frac{\delta_x^x}{m_x^2}\right) \delta^3(r_{xa}) \\ & + \pi \delta^3(r_{23}) - \frac{1}{2} p_2^i \left(\frac{\delta^{ij}}{r_{23}} + \frac{r_{23}^i r_{23}^j}{r_{23}^3}\right) p_3^j \\ & + \frac{1}{2} \sum_{x,a} \frac{1}{m_x} p_x^i \left(\frac{\delta^{ij}}{r_{xa}} + \frac{r_{xa}^i r_{xa}^j}{r_{xa}^3}\right) p_a^j \\ & - \frac{1}{2} \frac{1}{m_0 m_1} p_0^i \left(\frac{\delta^{ij}}{r_{01}} + \frac{r_{01}^i r_{01}^j}{r_{01}^3}\right) p_1^j, \end{aligned}$$

+ Relativistic recoil

Leading order QED $E^{(5)}$

$$\begin{aligned} E^{(5)} = & -\frac{2D}{3\pi} \ln k_0 - \frac{7}{6\pi} \left\langle \frac{1}{r_{23}^3} + \sum_{a,x} \frac{m}{m_x} \frac{1}{r_{ax}^3} \right\rangle_{\epsilon} + \frac{4}{3} \sum_{a,x} \left\{ \left(1 + \frac{m}{4m_x} + \frac{m^2}{m_x^2}\right) \ln(\alpha^{-2}) + \frac{19}{30} + \frac{m}{m_x} \frac{31}{6} + \frac{m^2}{m_x^2} \ln\left(\frac{m_x}{m}\right) \right\} \langle \delta^3(r_{ax}) \rangle \\ & + \left(\frac{164}{15} + \frac{14}{3} \ln \alpha\right) \langle \delta^3(r_{23}) \rangle - E_0^{(5)} - E_1^{(5)}, \\ E_x^{(5)} = & -\frac{4}{3\pi} \frac{\mu_x}{m} \left(\ln k_0(H) + \ln \frac{\mu_x}{m}\right) + \frac{4}{3\pi} \left(\frac{\mu_x}{m}\right)^3 \left\{ \left(1 + \frac{m}{4m_x} + \frac{m^2}{m_x^2}\right) \ln(\alpha^{-2}) + \frac{19}{30} + \frac{m}{m_x} \left(\frac{31}{6} + \frac{7}{2} \ln 2\right) + \frac{m^2}{m_x^2} \ln \frac{m_x}{m} \right\}, \end{aligned} \quad (13)$$

Computation of the Bethe logarithm

$$\ln k_0 = \frac{1}{D} \langle \vec{J}(H - E) \ln[2(H - E)] \vec{J} \rangle,$$

Most recent:

Pachucki and Komasa

JTCT 21, 12664 (2025)

Complete $\alpha^6 m$ corrections to the ground state of H_2

One Loop-correction

Two Loop-correction

Halted on $m\alpha^7$; also in He (IP problem 9σ off)

Status $D_0(\text{H}_2)$ 2026

The ionization and dissociation energies of molecular hydrogen

Ioana Doran¹, Charlaine Roth², Nicolas Hölsch¹, Maximilian Beyer², Wim Ubachs², Christian Jungen³, Kjeld S. E. Eikema^{2,*}, Frédéric Merkt^{1,4,5*}

Submitted

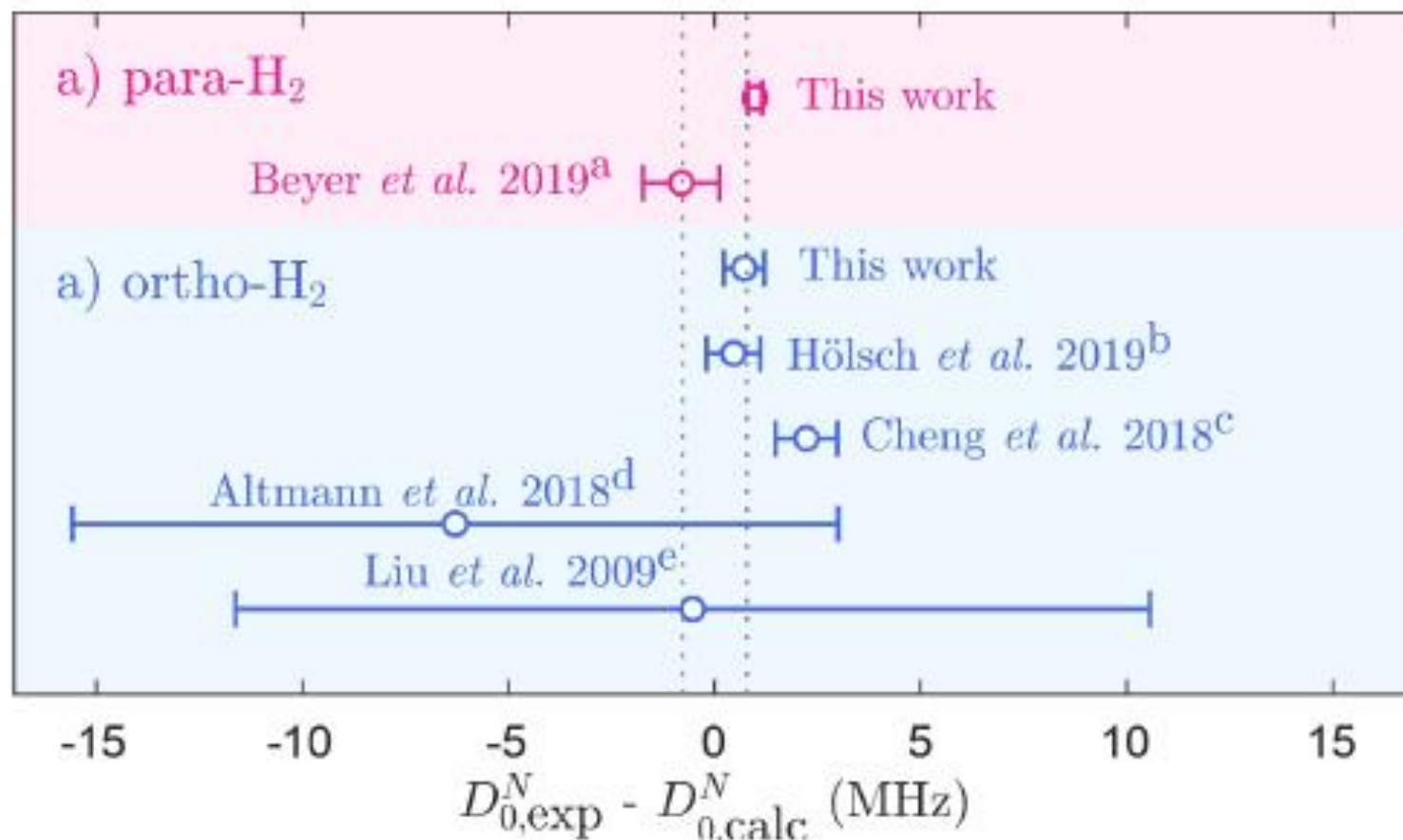

From 2 photon VUV (~ 1 MHz)

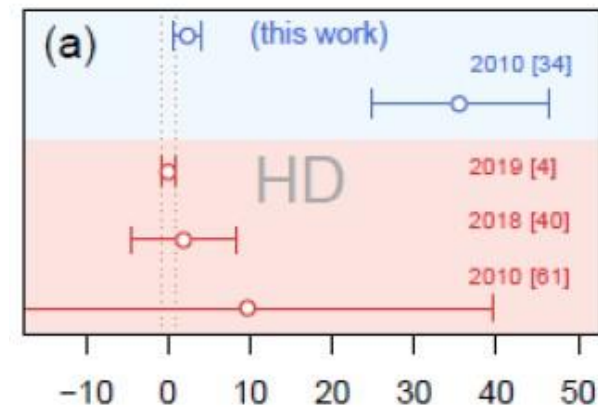

$D_0(\text{HD}) / \text{MHz} - 1091417901.42$

HD: Hölsch *et al.*,
Phys. Rev. A 108, 022811 (2023)

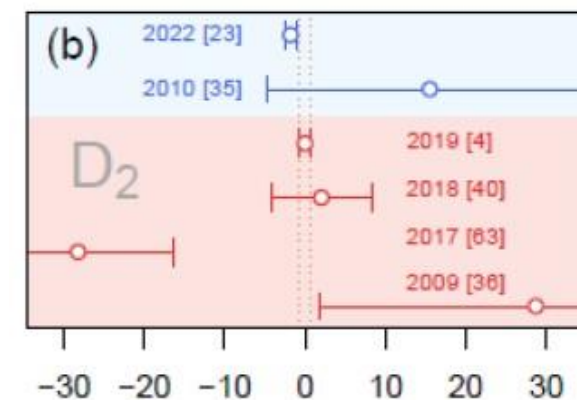

$D_0(\text{D}_2) / \text{MHz} - 1101688187.40$

D_2 : Hussels *et al.*,
Phys. Rev A 105, 022820 (2020)

Dissociation energy in the hydrogen molecule

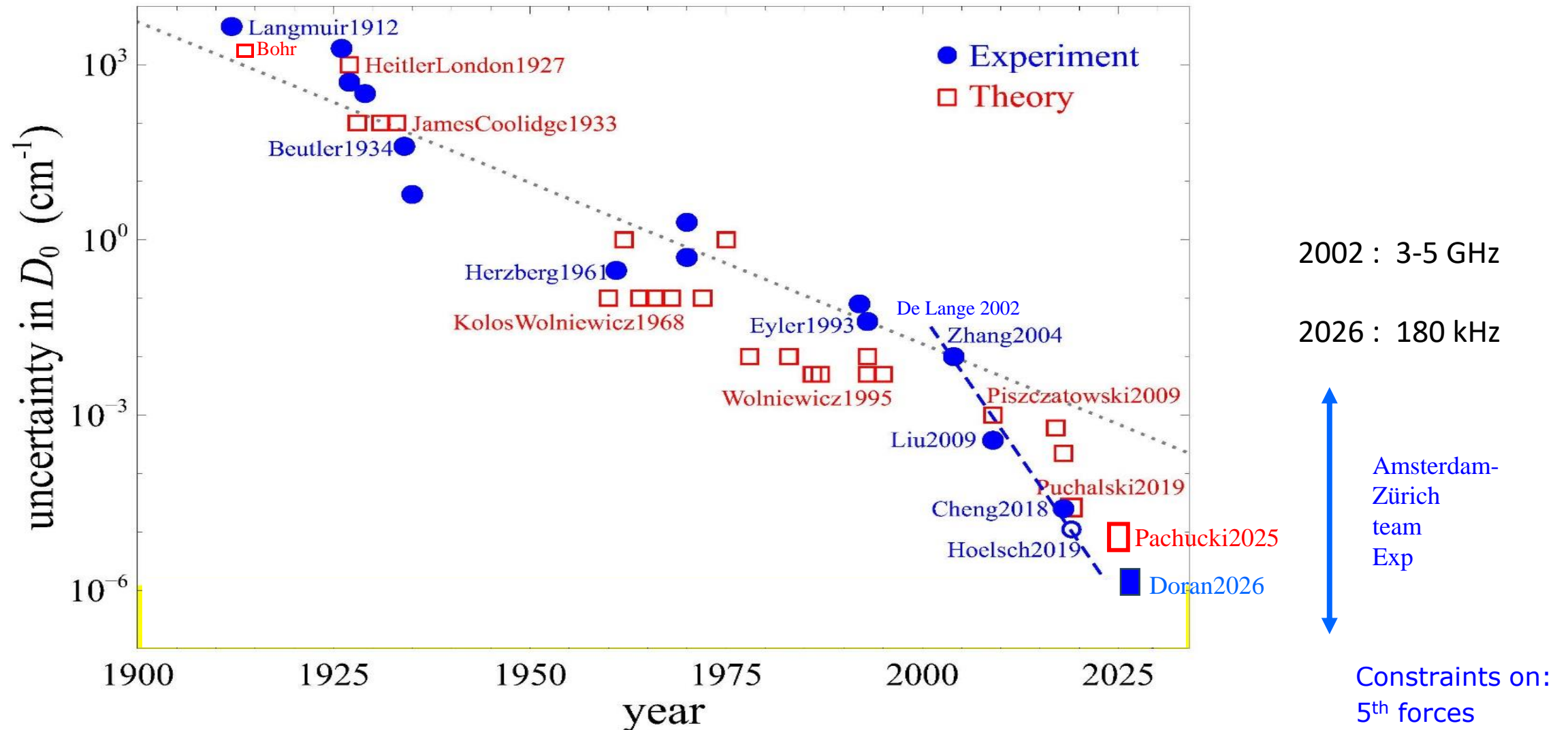

Switch gears:

Vibrational lines in the hydrogen molecules

First observation of H₂ quadrupole spectrum

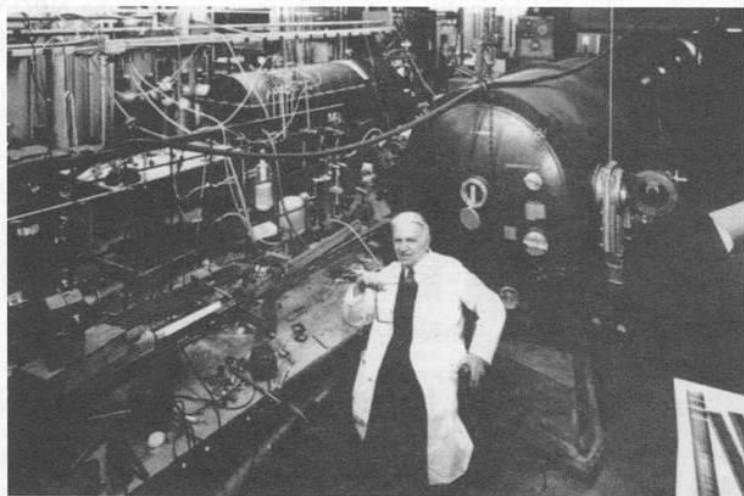

Herzberg in his laboratory.

Quadrupole Rotation-Vibration Spectrum of the Hydrogen Molecule

It is usually considered that molecular hydrogen does not have an infra-red rotation-vibration spectrum. However, such a spectrum may be expected as a forbidden transition made possible by the change of quadrupole moment during the vibration¹. The predicted intensity of this spectrum is so low that a path of the order of 10 km. at atmospheric pressure is required to obtain it in absorption^{1,2}.

Using a pipe of 22 m. length and letting the light pass through it up to 250 times³ at a pressure of 10 atmospheres, it was possible to obtain equivalent path-lengths up to 55 km. atmospheres. Under these conditions a number of lines of the 2-0 and 3-0 bands of the hydrogen quadrupole spectrum were indeed observed. The accompanying table compares the observed wave numbers with those predicted from the ultra-violet hydrogen spectrum⁴. The bands have only *S*, *Q* and *O* branches. Because of the small moment of inertia of the hydrogen molecule, only the first few lines of the *S* and *Q* branches are sufficiently intense for observation. No lines of the *O* branches were found.

Wave-numbers of quadrupole lines of H₂

Band	Line	ν (predicted)	ν (observed)
2-0	<i>S</i> (0)	8,403	8,406.36
2-0	<i>S</i> (1)	8,601	8,604.26
2-0	<i>S</i> (2)	8,782	8,785.54
2-0	<i>Q</i> (1)	8,072	8,075.42
3-0	<i>S</i> (0)	12,080	12,084.66
3-0	<i>S</i> (1)	12,261	12,265.55
3-0	<i>S</i> (2)	12,420	12,424.44
3-0	<i>Q</i> (1)	11,760	11,764.96

The slight systematic difference of observed and predicted wave-numbers is due to the much lower wave-number accuracy in the vacuum ultra-violet and the lack of standards in this region. It is hoped to obtain improved rotational and vibrational constants of the hydrogen molecule in the ground-state from the wave-numbers of the quadrupole lines.

It appears that the spectrum here observed is the first example of quadrupole radiation in molecular spectra.

G. HERZBERG

Yerkes Observatory,
Williams Bay, Wis.
Aug. 24.

¹ See Herzberg, G., *Astrophys. J.*, **87**, 428 (1938).

² James, H. M., and Coolidge, A. S., *Astrophys. J.*, **87**, 438 (1938).

³ Bernstein, H. J., and Herzberg, G., *J. Chem. Phys.*, **16**, 30 (1948).

NICEOHMS: Noise-Immune Cavity-Enhanced Optical-Heterodyne Molecular Spectroscopy¹

Frequency Modulation Spectroscopy (Bjorklund 1980), but in a cavity

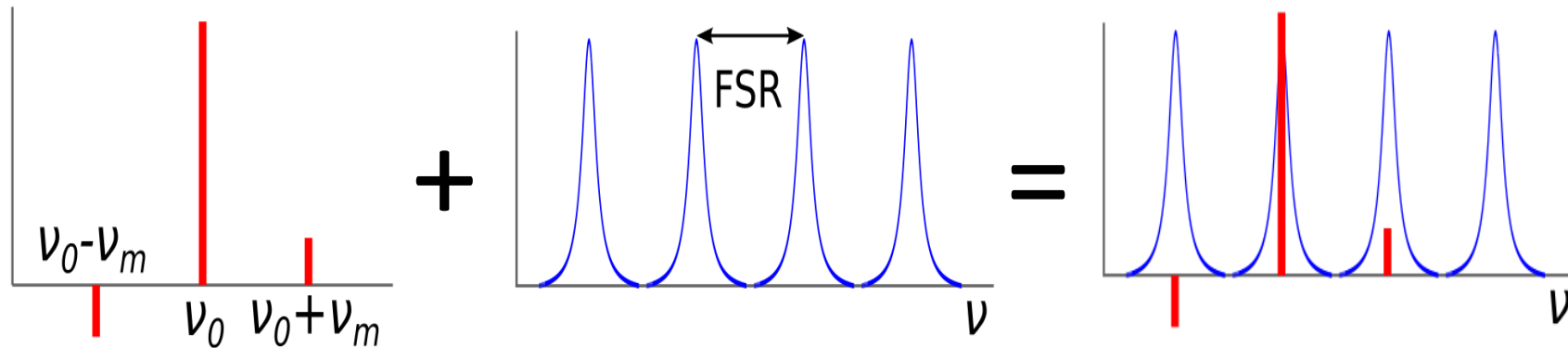

$$\Delta\alpha = \frac{1}{J_0(\beta)J_1(\beta)} \frac{\pi}{2\mathcal{F}} \frac{2}{L} \sqrt{\frac{h\nu B}{\eta P_0}}$$

+ Additional Wavelength Modulation
“wm-NICEOHMS” (Axner 2008)

+ Calibration + locking
with Frequency comb

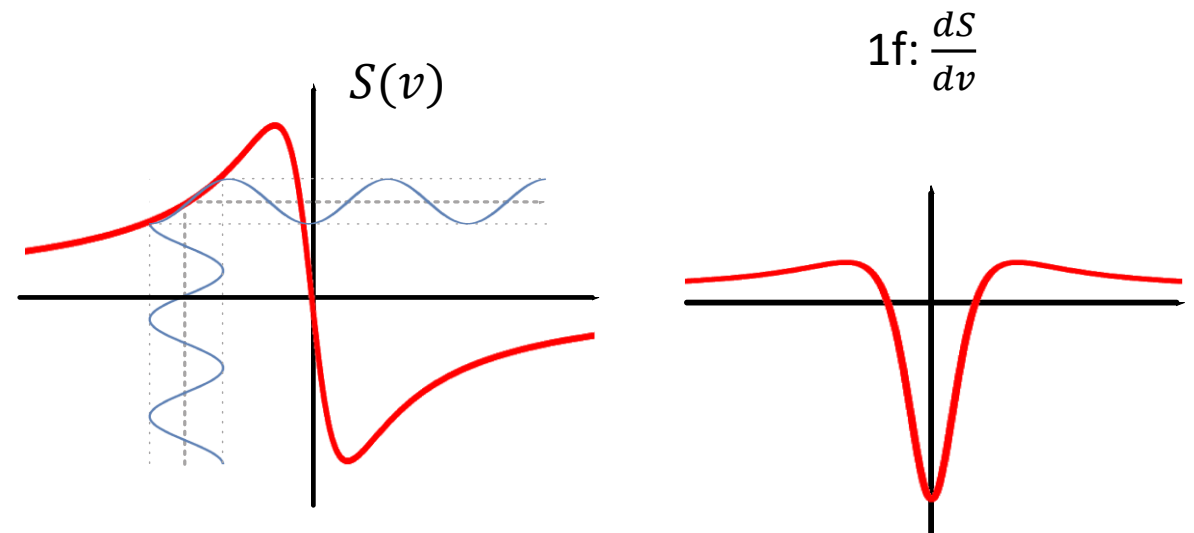

(1) J. Ye, L.-S. Ma, and J. Hall, Opt. Lett. **21**, 1000 (1996)

NICE-OHMS cryo-spectrometer

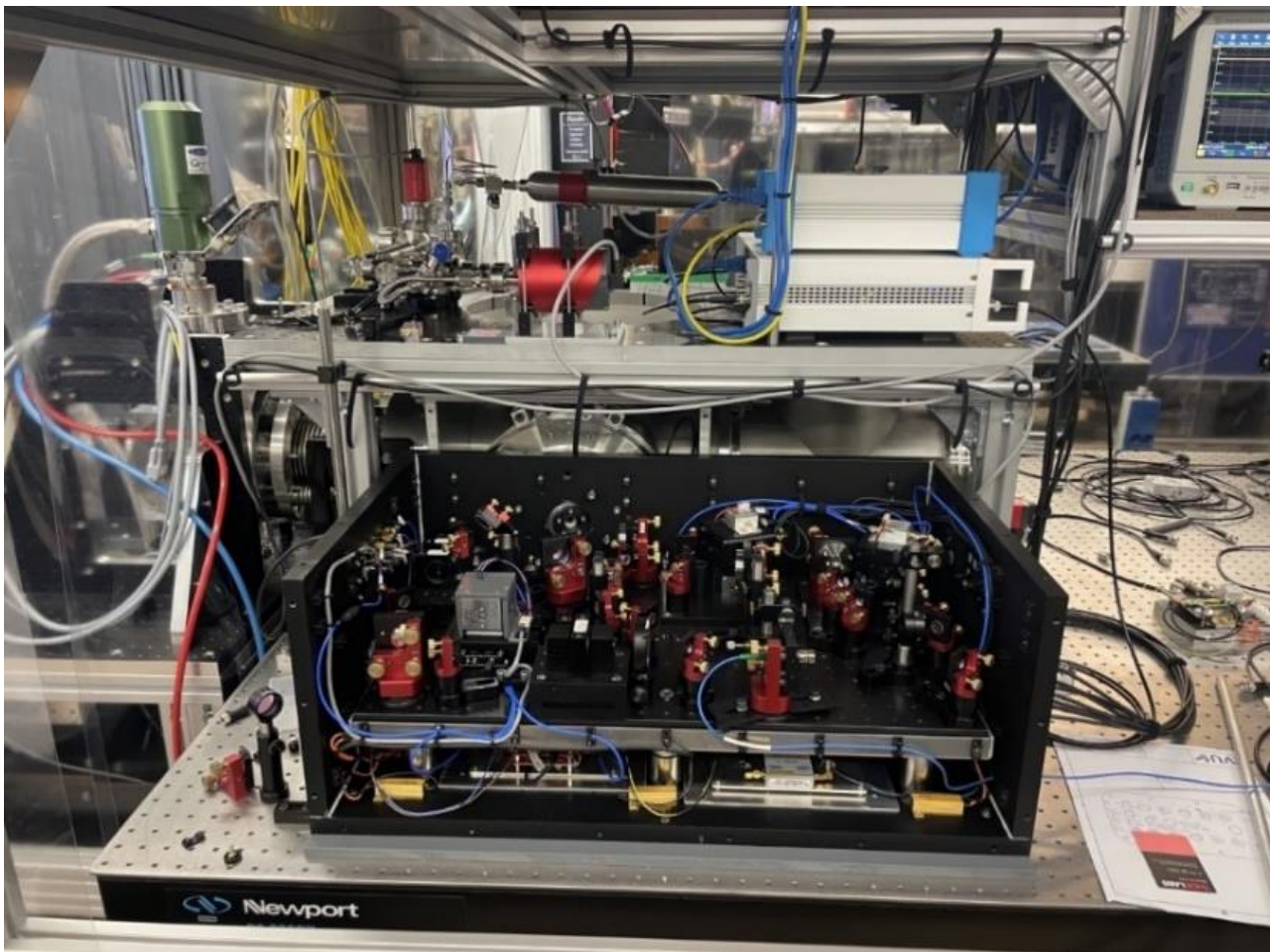

For para-H₂

- No hyperfine structure
- Target S(0) (2-0) line

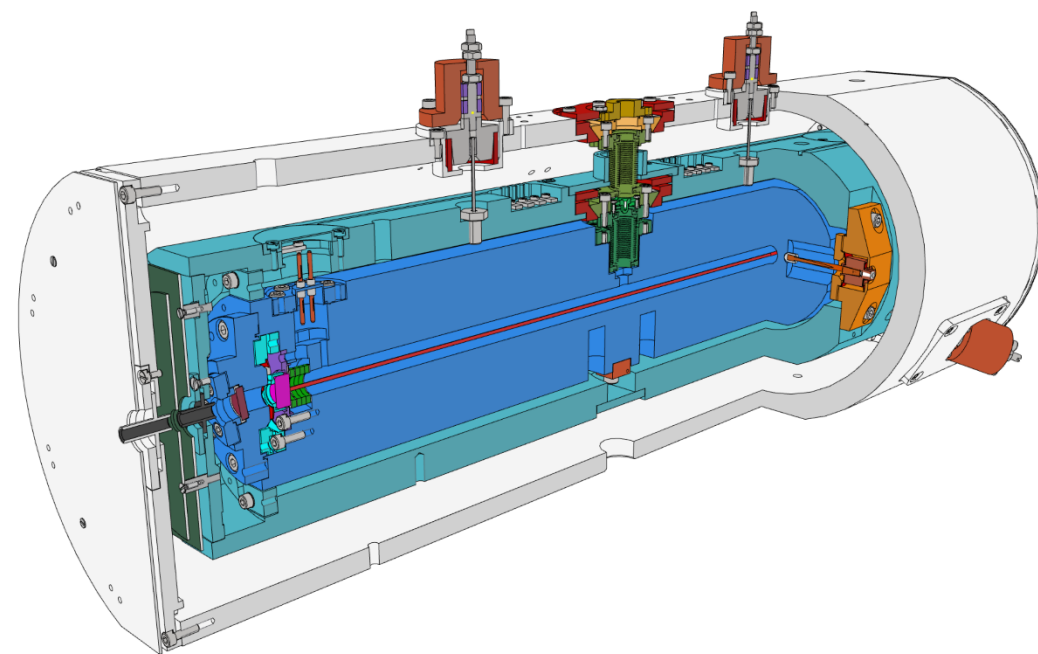

New setup built:

- vibration-isolated cryo-cooled cavity setup,
- laser locked to frequency comb
- improved free-space EOM
- tapered amplifier diode laser at 1189 nm
- Q factor of > 300,000 with ~10 kW circulating

Lamb dip of a quadrupole transition

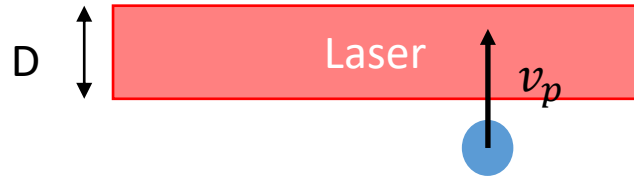

Limitation:
Transit-time broadening



Meissa
Diouf



Frank
Cozijn

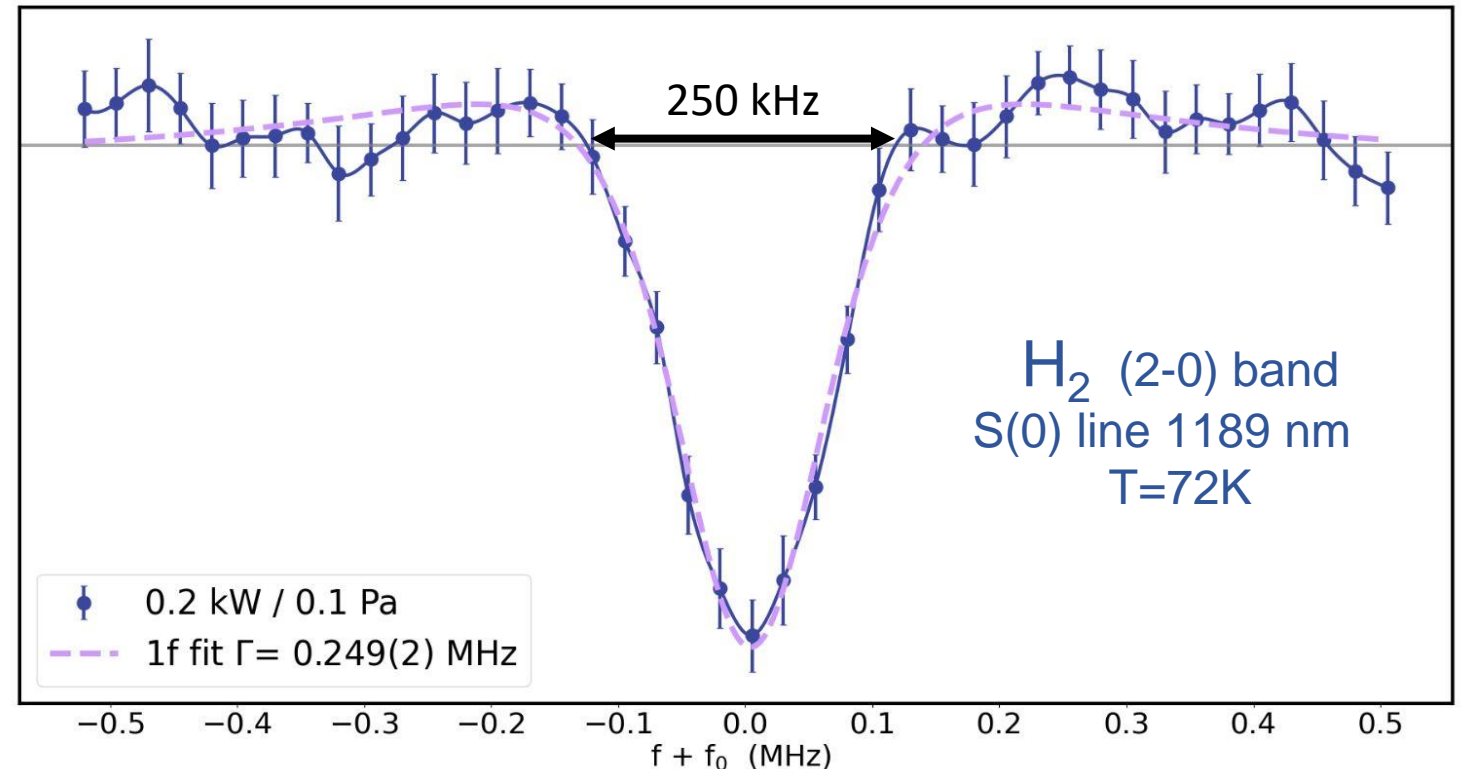

Recoil doublet in saturation?

$$\pm \frac{(h\nu_0)^2}{2mc^2} \quad \pm 70 \text{ kHz}$$

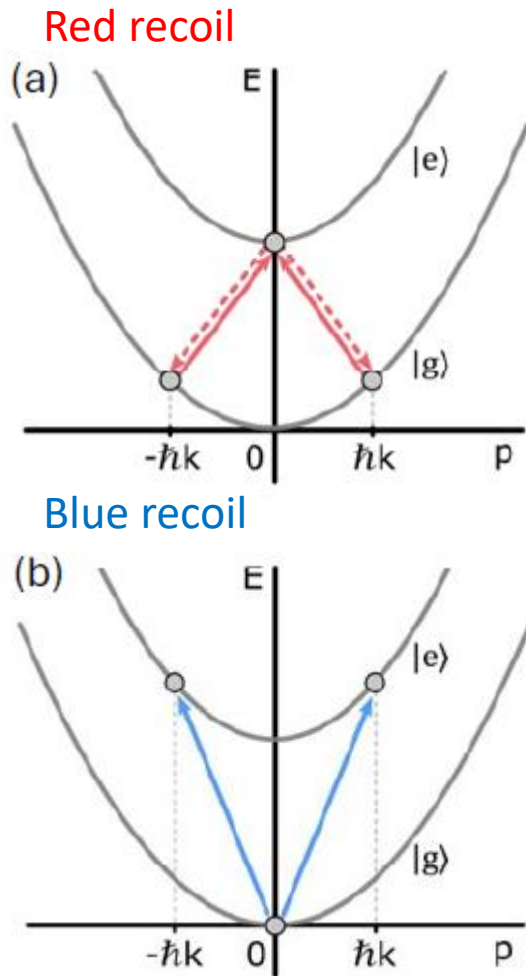

CH₄ line / HeNe laser (3.39 μm)

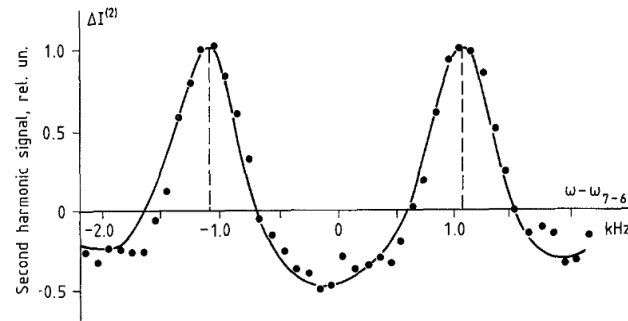

Theory:

A.P. Kol'chenko *et al*,
Sov. Phys. JETP 55, 1864-1873 (1968)

Observations in Methane

J.L. Hall, C.J. Bordé, K. Uehara,
Phys. Rev. Lett. 37, 1339 (1976)
S.N. Bagayev *et al*,
Appl. Phys. B 52, 63-66 (1991)

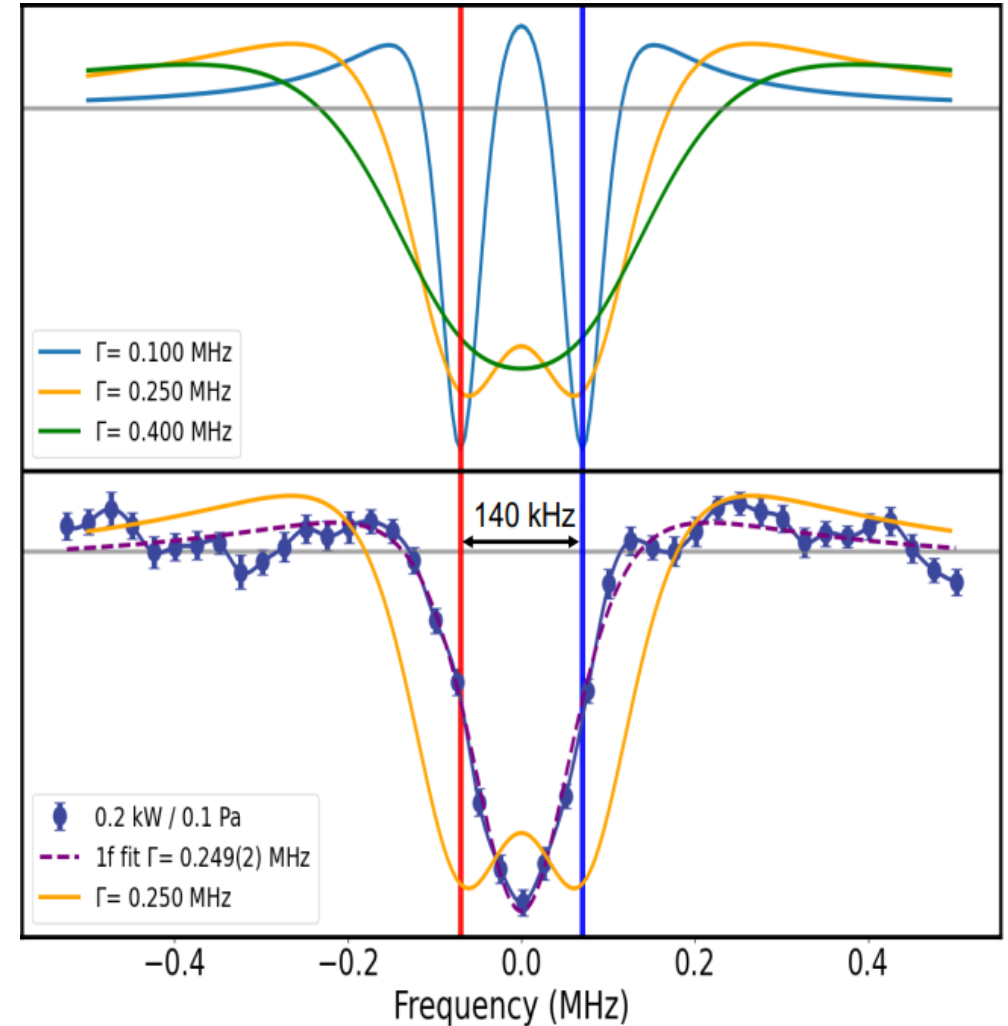

Conclusion: one component suppressed

Saturation conditions

$S = 3.0 \times 10^{-27}$ cm/molecule at 72 K [Kassi, Campargue]

$I = 3.25 \times 10^8$ W/m² [150 W in $w_0 = 0.54$ mm]

$v = 770$ m/s at 72 K

$$s = \frac{2 S_{ge} I c}{\pi \Gamma^2 h f}$$
$$\Gamma \approx \frac{1}{2\pi} \frac{v}{2w_0}$$
$$n_e = \frac{s/2}{s+1}$$

Population in excited state during saturation: $n_e = 3 \times 10^{-4}$

Result (assume red component suppressed)

Transition frequency of H₂ (2-0) S(0):
252 016 361 164 (8) kHz

In agreement:

Pachucki and Komasa, JTCT 21, 12664 (2025)

theory	25,2016,361.45(69)
experiment	25,2016,361.164(8) ^e
difference	0.28(69)

Tricks with the NICE-OHMS setup

Sideband-sideband NICE-OHMS saturated operation in H₂

- Previously: spectroscopy with carrier 150 W
- Now: Perform spectroscopy with the sidebands
- Either on **blue** or **red**
- Molecules fly orthogonal
- Again Lamb dips

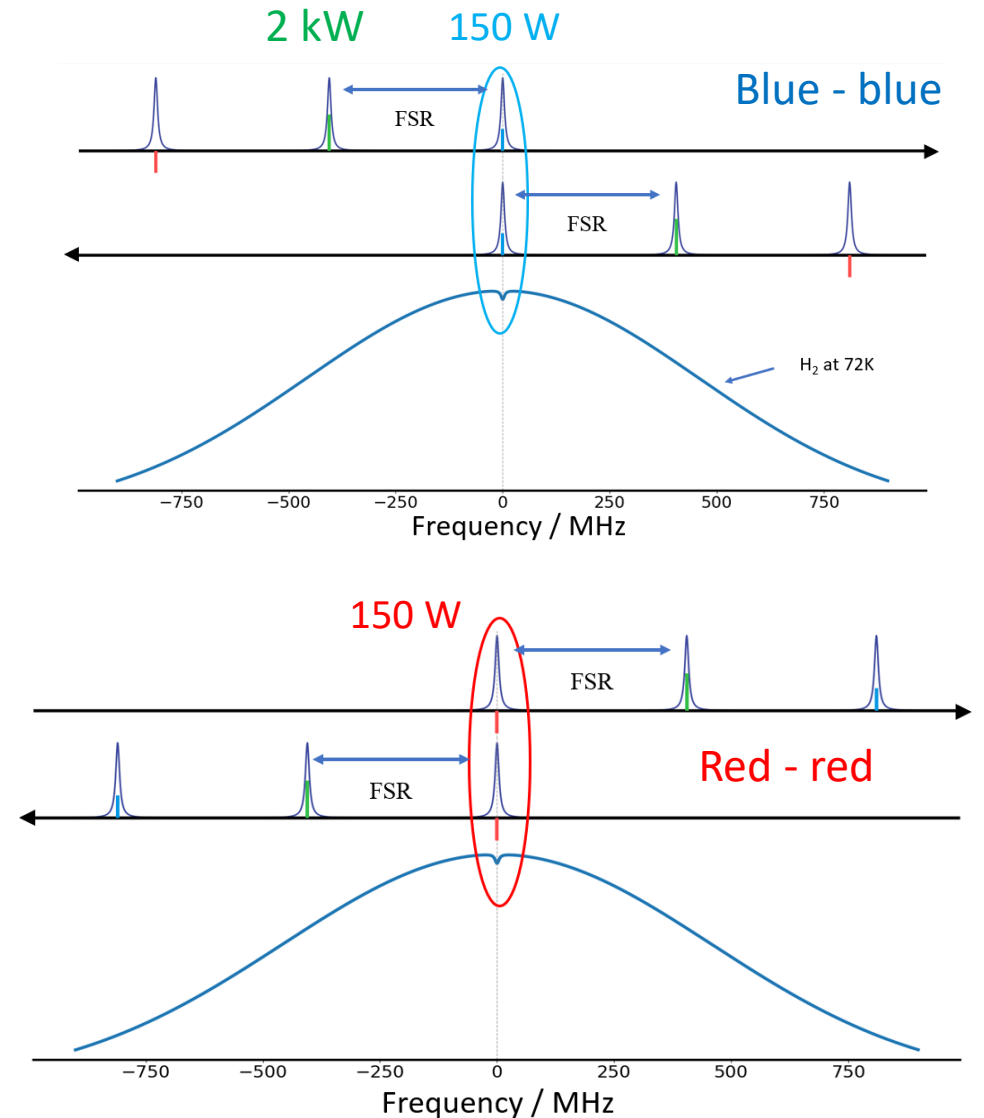

Sideband-sideband saturation in H₂:

Equal intensity in all three measurements (RR, CC, BB)

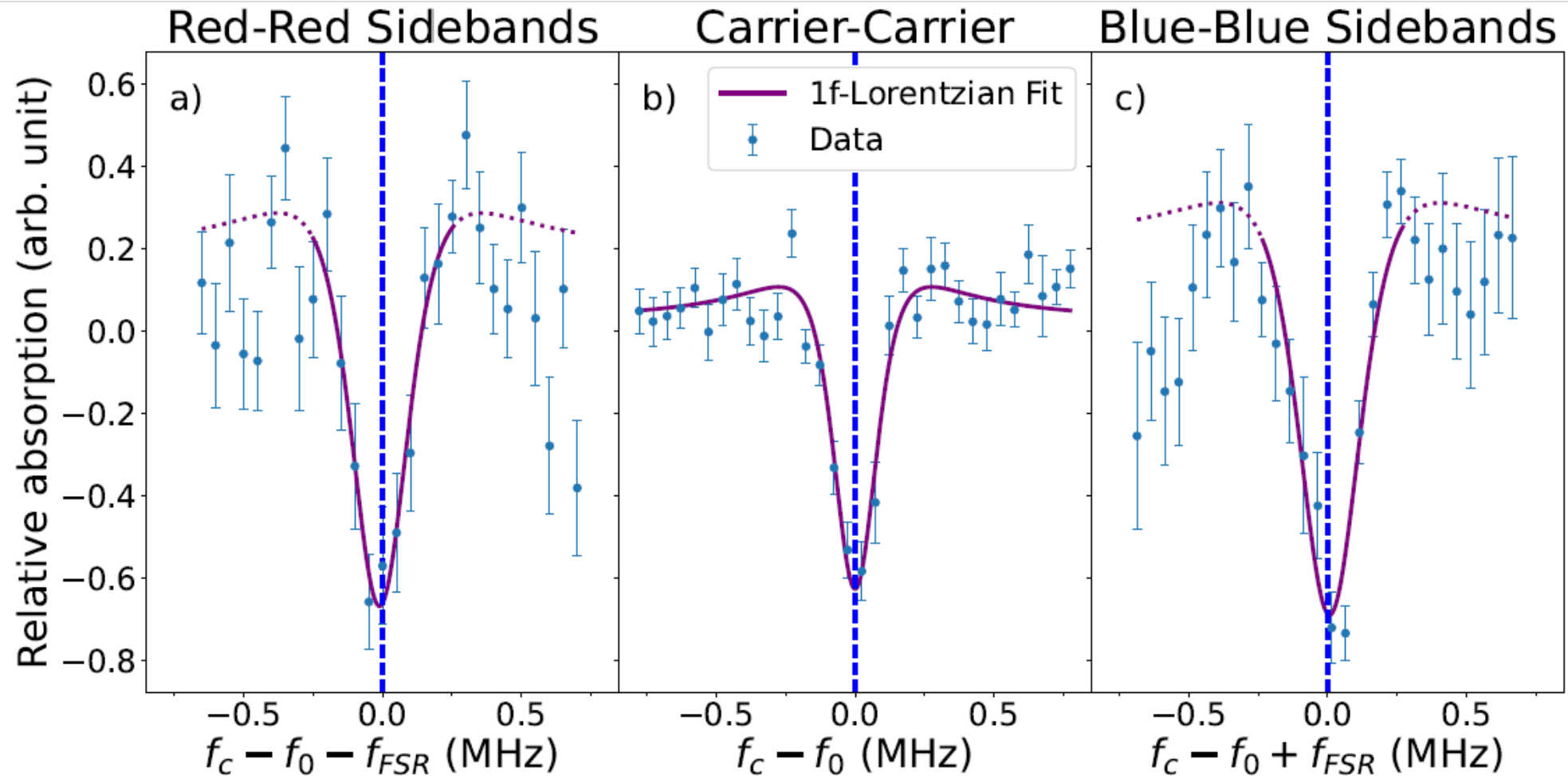

Frequency / MHz

Mind the blue line !

Sideband-sideband NO (!) saturation in H₂

- f Detuned by $\pm\text{FSR} = 404$ MHz
- **Weak on-resonance standing wave (<1 W)
Cannot saturate !**
- Sideband power can be varied over 4 orders of magnitude
Strong off-resonance standing wave (kW)
 - Either at left or right side of resonance

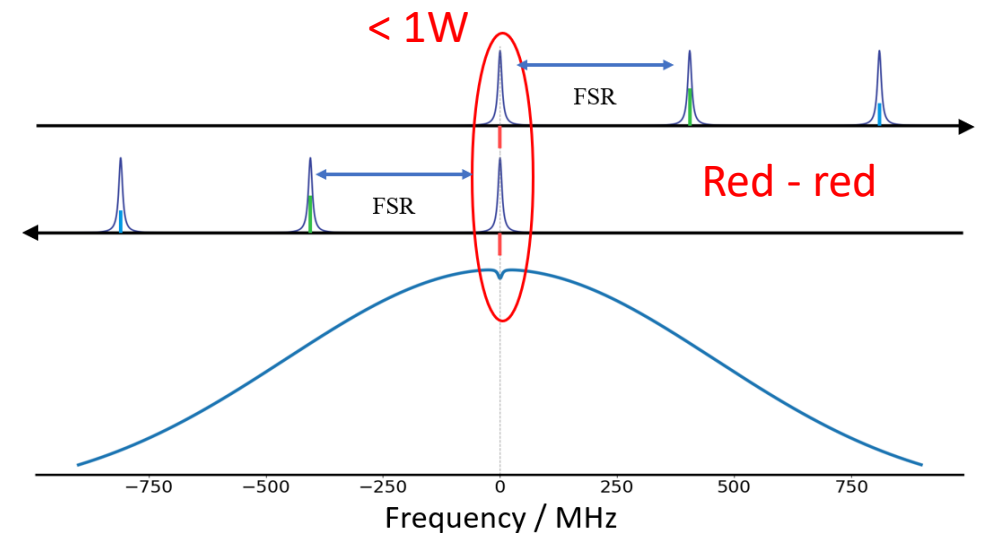
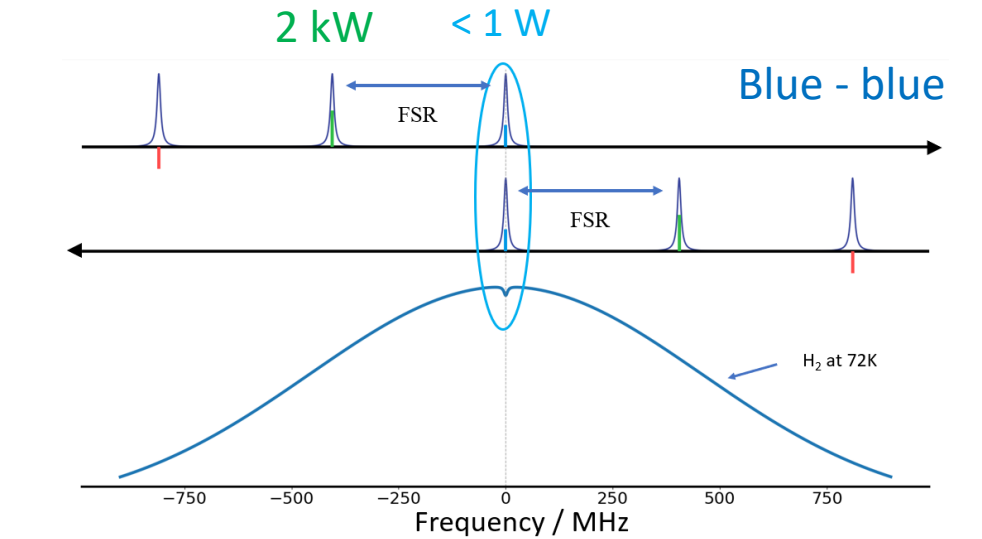

Sideband-sideband linear absorption in H₂: with strong (kW) detuned laser at $\Delta f \sim 404$ MHz

- Carrier is a few kW
- Off resonance
- Sideband on resonance
- Sideband only 1 Watt
- Sideband LOW power
- NO saturation

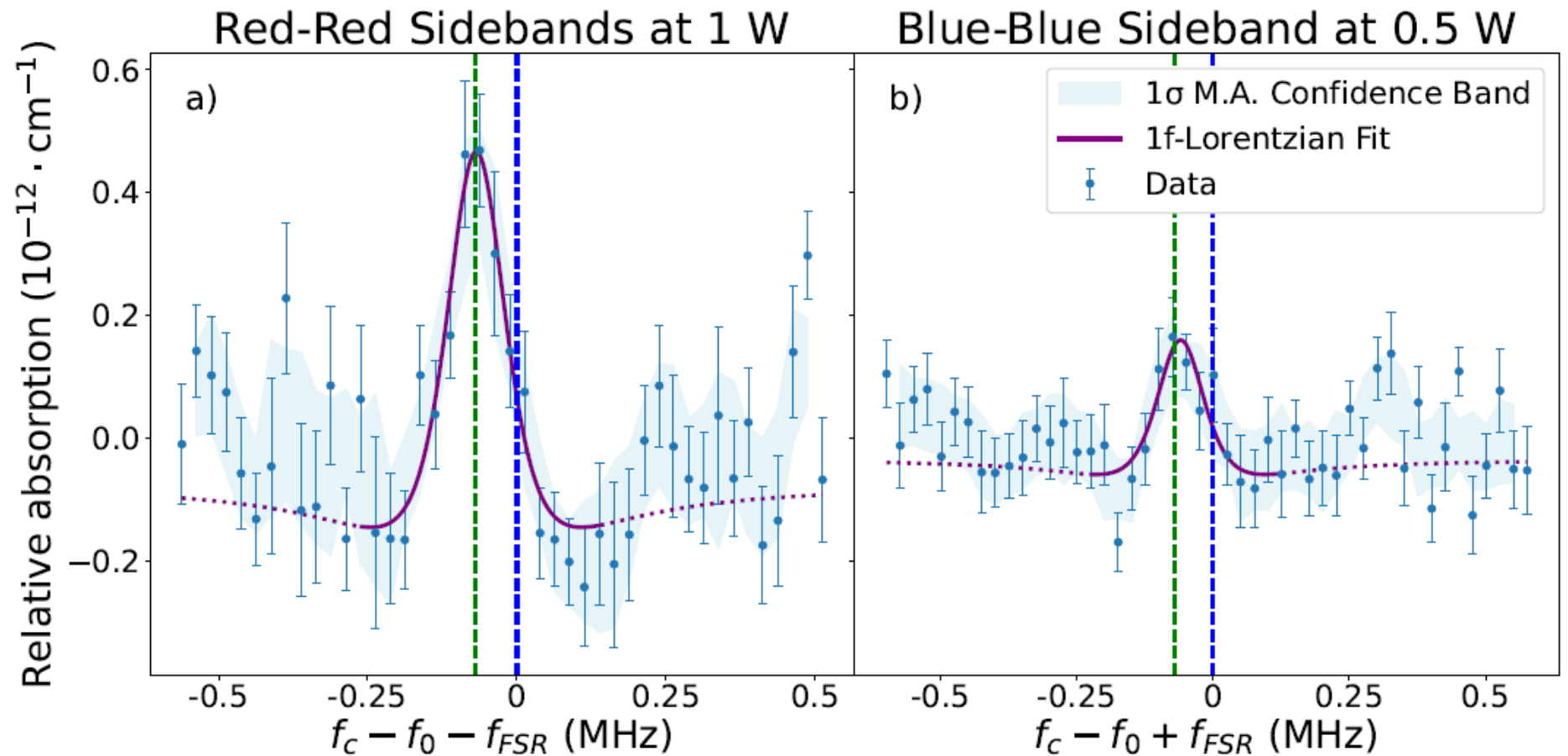

Green line; shift by 1 recoil (70 kHz)

Prediction of 1D-Trapping/Optomechanical effects

Letokhov – Chebotayev effect

Features/Proofs:

- (1) Amplitude sign reversal from Lamb dip to absorption
- (2) Narrow width of ~ 250 kHz in linear absorption
Same width as Lamb dip (transit-time limit)
Doppler width at 72 K should be 1 GHz
- (3) Signal peak at zero-recoil position (Lamb-Dicke regime) **1D**
- (4) Molecules taken from within the “wings” in the peak

Zero-recoil – So we see the blue recoil as a Lamb dip !!

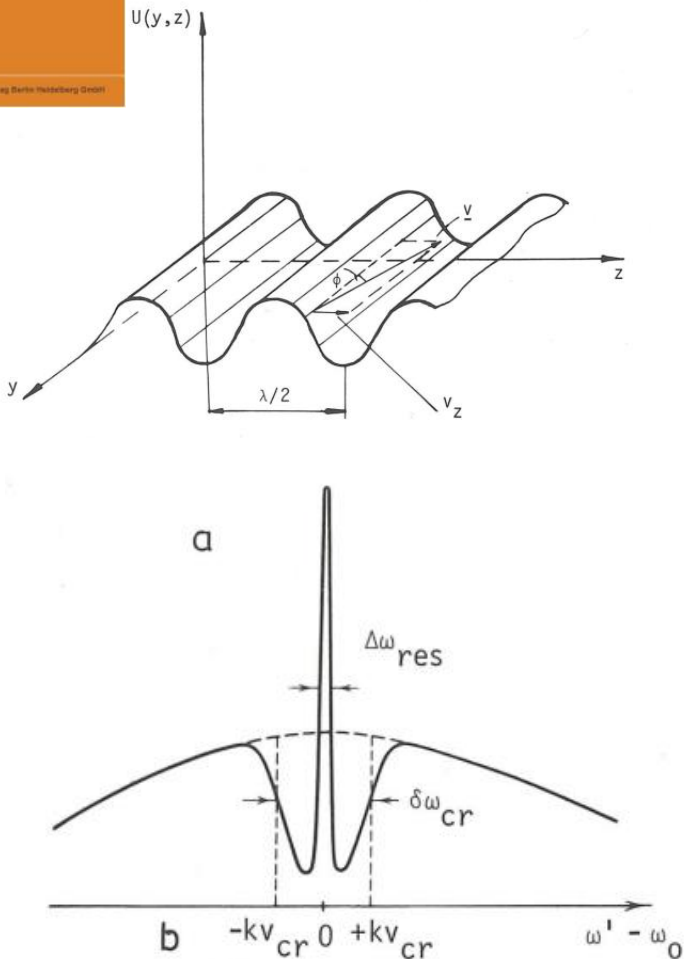

Thanks



NICEOHMS



Frank
Cozijn



Meissa
Diouf



Ioana
Doran



Charlaine
Roth



Joel
Hussels



Cunfeng
Cheng

1D-trapping



Piotr
Wcislo



Clement
Lauzin



Max
Beyer



Edcel
Salumbides



Kjeld
Eikema



Frederic
Merkt

Number of molecules

1) Estimate

Trapping volume: $V = \pi \omega_0^2 L$; $L=37$ cm, $w_0 = 0.54$ mm; $V = 3.5 \times 10^{-7} \text{ m}^3$

Assume 1/3 of molecules in trapping zone (intensity peaks)

$p = 0.5 \text{ Pa}$, $T=72$ K, fraction **25%** of molecules in $J=0$ (no ortho-para conversion in cavity)

→ 1.5×10^{13} particles; a fraction of these (3×10^{-4}) has a velocity below 0.21 m/s (below 5.3 μK)

Trapping power: **2 kW** on carrier; in the waist $I = 4.33 \text{ kW/mm}^2$

Dipole polarizability of H_2 at 1189 nm: $\langle \alpha_v \rangle = 5.45 \text{ a.u.}$ or $9 \times 10^{-41} \text{ C}^2\text{m}^2\text{J}^{-1}$

Trap depth: $U_0 = \frac{I}{2\epsilon c} \langle \alpha_v \rangle = 5.3 \mu\text{K} \times k_B$

4×10^9 trapped particles in 6×10^5 intensity peaks ($\lambda = 1189$ nm and $L=37$ cm)

7000 trapped molecules in each trapping site

2) Estimate from absorption depth; factor of 2 less; “out of phase” effect

Extra Dimensions ?

ADD Model

Arkani-Hamed, Dimopoulos, Dvali

Phys. Lett. B **429**, 263–272 (1998)

Hierarchy Problem:

Why is gravity so much weaker ?

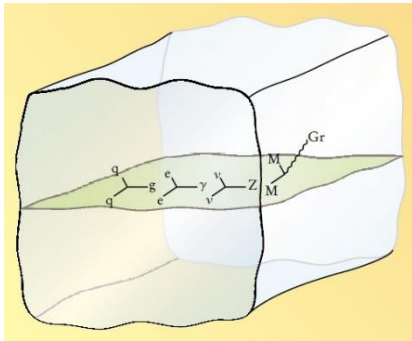

Solution :
Gravity “escapes” into higher dimensions
3-brane (SM) and “Bulk” (gravity)

Flux Law (Gauss law)

3-dim: $A_V \propto r^2 \Rightarrow F \propto \frac{1}{r^2}$

N-dim: $A_V \propto r^{N-1} \Rightarrow F \propto \frac{1}{r^{N-1}}$

Compactification

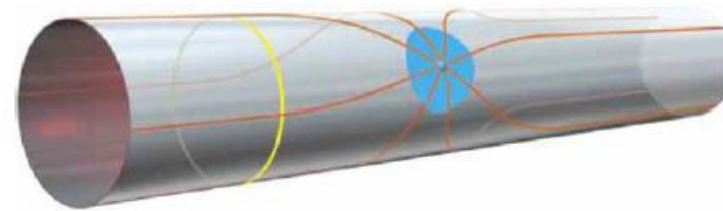

Oscar Klein

$$V_{ADD}(r) = -G_3 \frac{m_1 m_2}{r} \left(\frac{R_{comp}}{r} \right)^n$$

Enhancement factor
for gravity in n extra
dimensions

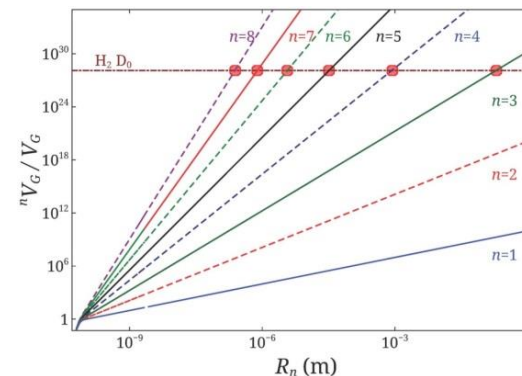

Constraint from H_2 spectrum:
M-theory (10+1 dim):
Compactification on μm scale !!
 $R_{comp} < 0.6 \mu\text{m}$ - from $D_0(H_2)$

Numerics on 1D-Trapping

Trapping power: **2 kW** on carrier; in the waist $I = 4.33 \text{ kW/mm}^2$

Dipole polarizability of H_2 at 1189 nm: $\langle \alpha_\nu \rangle = 5.45 \text{ a.u.}$ or $9 \times 10^{-41} \text{ C}^2\text{m}^2\text{J}^{-1}$

Trap depth: $U_0 = \frac{I}{2\epsilon c} \langle \alpha_\nu \rangle = 5.3 \mu\text{K} \times k_B$

Produces energy ladder: $E_n = h\nu(n + \frac{1}{2}) = E_{\text{tr}} \sqrt{2U_0/mc^2}(n + \frac{1}{2})$

Lowest level ($n=0$) at $4.2 \mu\text{K}$, so in fact just trapping for a **single lowest quantized kinetic level**

Quantized kinetic energy

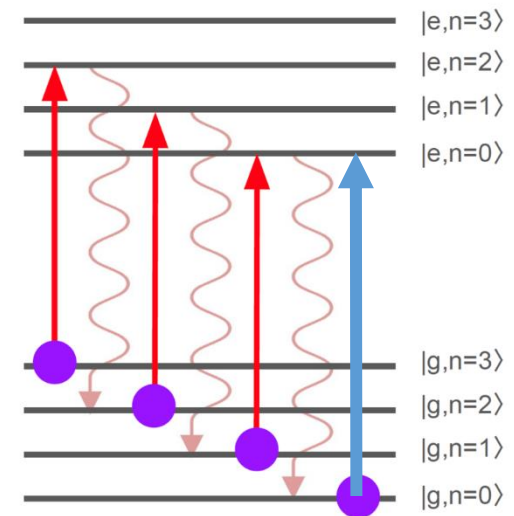

**Zero-recoil (0,0)
Linear absorption**

AC Stark effect:

Dynamic polarizability
(electric dipole contribution)
Raj 2019: (v, J), **atomic units**

mean (α)
(0,0): 5.4472936(5)
(2,2): 6.4529324(7)

polarizability anisotropy (γ)
(2,2): 3.0658412(4)

effective polarizability for given
v, J, M_J

$$\langle \alpha \rangle_{vJM_J} = \alpha_{vJM_J} - \frac{2}{3} \gamma_{vJM_J} \frac{3M_J^2 - J(J+1)}{(2J-1)(2J+3)}$$

Differential polarizability:

$$\langle \alpha \rangle_{v=2,J=2,M_J} - \langle \alpha \rangle_{v=0,J=0,M_J=0}$$

$$\langle \alpha \rangle_{v=2,J=2,M_J=0} - \langle \alpha \rangle_{v=0,J=0,M_J=0} \\ = 1.58961$$

$$\langle \alpha \rangle_{v=2,J=2,M_J=1} - \langle \alpha \rangle_{v=0,J=0,M_J=0} \\ = 1.29762$$

$$\langle \alpha \rangle_{v=2,J=2,M_J=2} - \langle \alpha \rangle_{v=0,J=0,M_J=0} \\ = 0.42167$$

AC Stark shift due to $\langle \alpha \rangle$

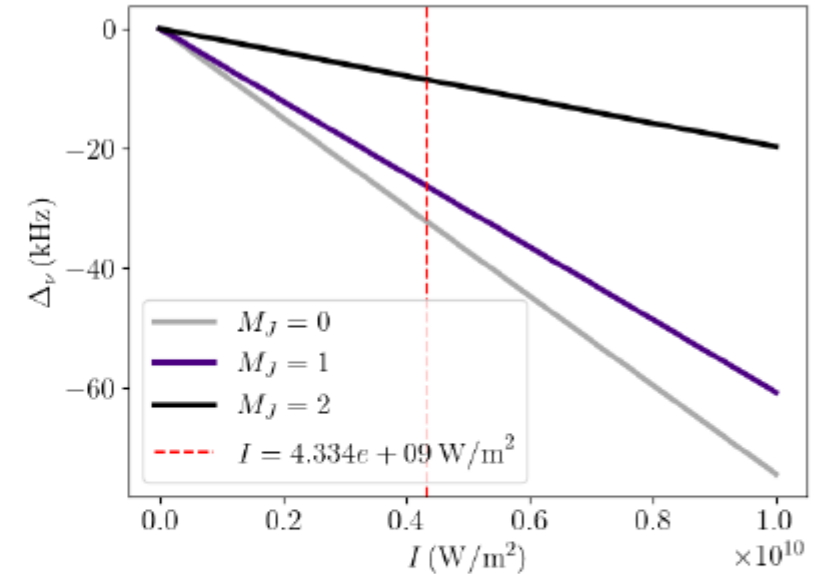

For $I = 4.334 \text{ kW}/\text{mm}^2$:

$$\Delta_v = -32.291 \text{ kHz } (M_J=0)$$

$$\Delta_v = -26.360 \text{ kHz } (M_J=1)$$

$$\Delta_v = -8.566 \text{ kHz } (M_J=2)$$

Even less shift observed

“Out-of-phase effect”

Conclusion: Quantum Mechanics works

Outlook

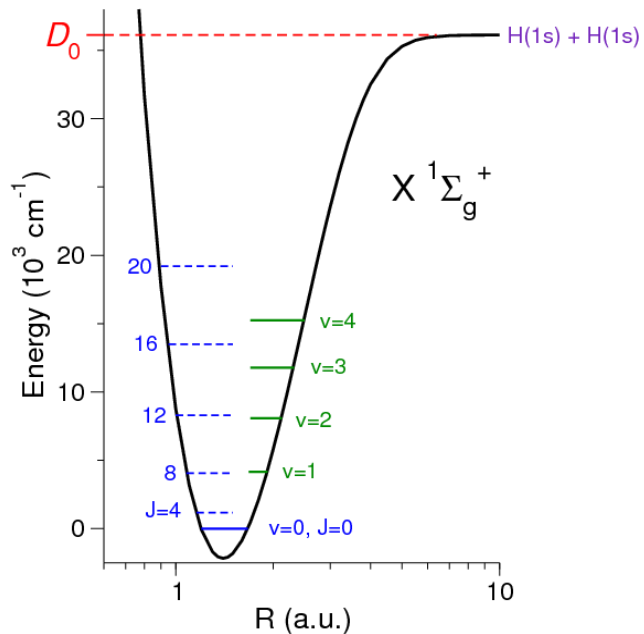
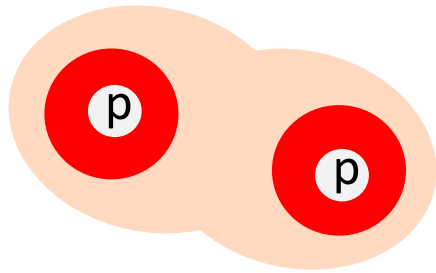

- **H_2 good Quantum test system**

- **> 300 quantum states**
- **Lifetime 10^6 seconds (days)**
- **Transitions $\sim 10^{14}$ Hz**
- **Possible precision 20-digit**

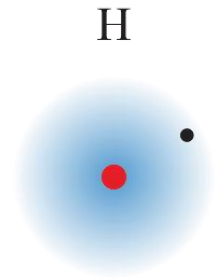

Lifetime 0.12 seconds

