

Report of Pan-Canada MRS-Supported Facilities

CINP/IPP Sessions at 2026 CAP Congress

Jean-François Arguin (U. de Montréal)

What is an MRS technical resource?

- **Even though our experiments can be very different, we share similar needs in expertise to build them:**
 - E.g.: custom (high-speed) electronics and firmware design, high-precision mechanical fabrication, and detector characterization / beam-based calibration
- **The NSERC Major Resource Support grant** program has been leveraged to maintain (for the long term) hubs of expertise in Canada
 - From West to East: Alberta, Winnipeg, Carleton, McGill, Montréal

Why should you care?

- This expertise is available to the whole Subatomic Physics Canadian community **for free**
 - **The personpower is free of charge**, you only need to pay for the material/equipment
- The MRS grant allows **to keep this precious expertise** in Canada's SAP community for the **long term**
 - **Challenging nowadays to hire engineers and technicians and compete with the private sector**
- The MRS resources **support HQP training** in the design and construction of experiments
- They support large established projects, but can also **lower the barrier to start — prototype a new idea** before you have dedicated project funding

Organization

- The job requests are received by a Pan-Canadian board that manage the MRS resources

Name	Role	Institution
Jean-François Arguin	UdeM rep.	U. de Montréal
Miriam Diamond	At large	U. of Toronto
Kevin Graham	Carleton rep.	Carleton U.
Garth Huber	CINP Director	U. Regina
Blair Jamieson	Winnipeg rep.	U. Winnipeg
Greg Christian	At large	St Mary's U.
Jim Pinfold	Alberta rep.	U. of Alberta
Fabrice Retiere	TRIUMF rep.	TRIUMF
Carsten B Krauss	IPP Director	U. of Alberta
Brigitte Vachon	McGill rep.	McGill U.

- Winnipeg MRS recently got funded again. New technician has been identified, will take new requests soon
- Both McDonald IPDC and MRS share the same goal. Different expertise/people are offered in both streams

MRS – CPP+ (Alberta) - Personnel

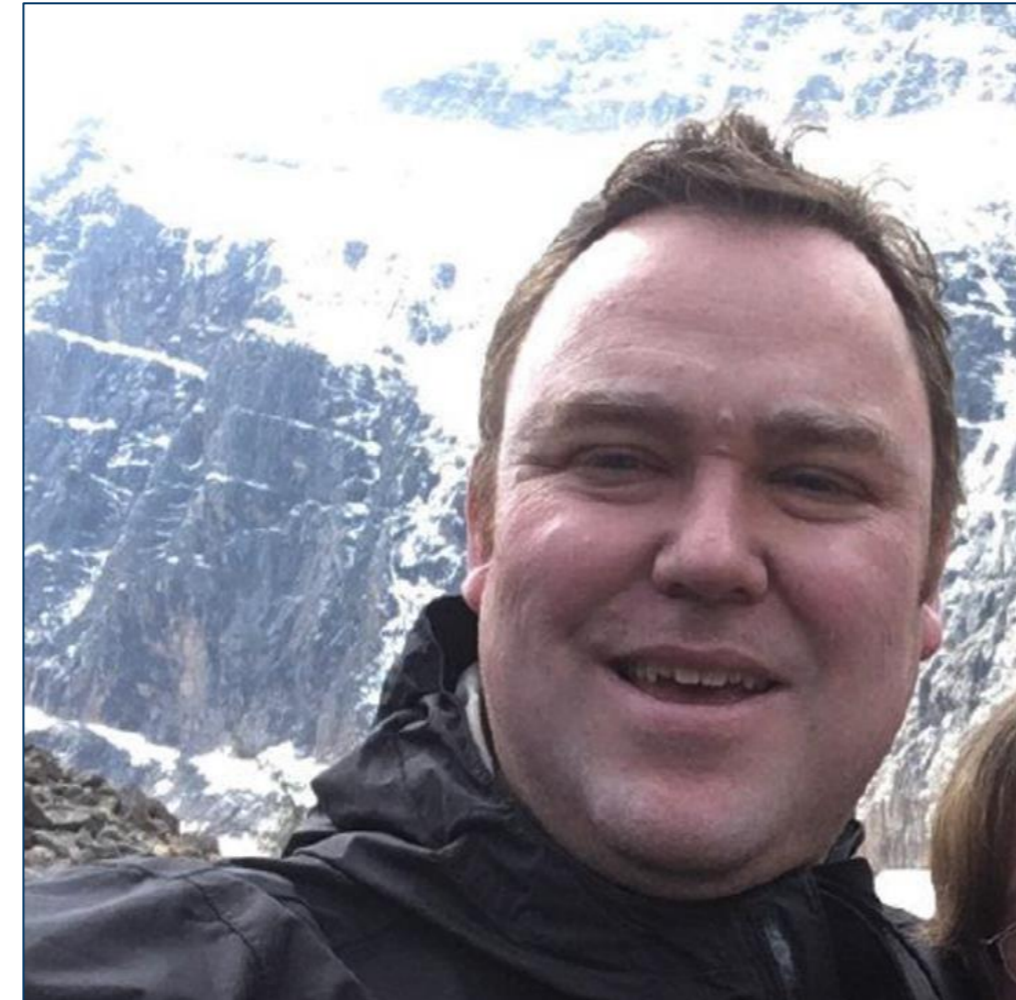

*Mitchel Baker**

Qualified Mechanical Eng.



Paul Davis

Electronics Engineer.



Richard Soluk

Electronics Engineer.

**1. Mech. Engineer
(with stamp)***

2. Electronics Eng.

**3. Detector
Technologist**

● *Funding cut in 2025 reduced funding by ~30%.*

● *Thus, 30% of MRS Program is being funded by non NSERC-MRS sources*

***NB Note that Mitchel Baker is the only registered engineer in the MRS resource**

MRS – CPP+ (Alberta) - Resources



UNIVERSITY OF
ALBERTA

1. Registered engineer (CAD, FEI, Thermal)
2. Cryogenic design
3. Fast Analog & digital electronics design
4. Multi-layer PCB des.
5. DAQ software
6. ASIC design
7. FPGA programming
8. CNC machining
9. Radon Free const.
10. Detector design
11. Glass blowing

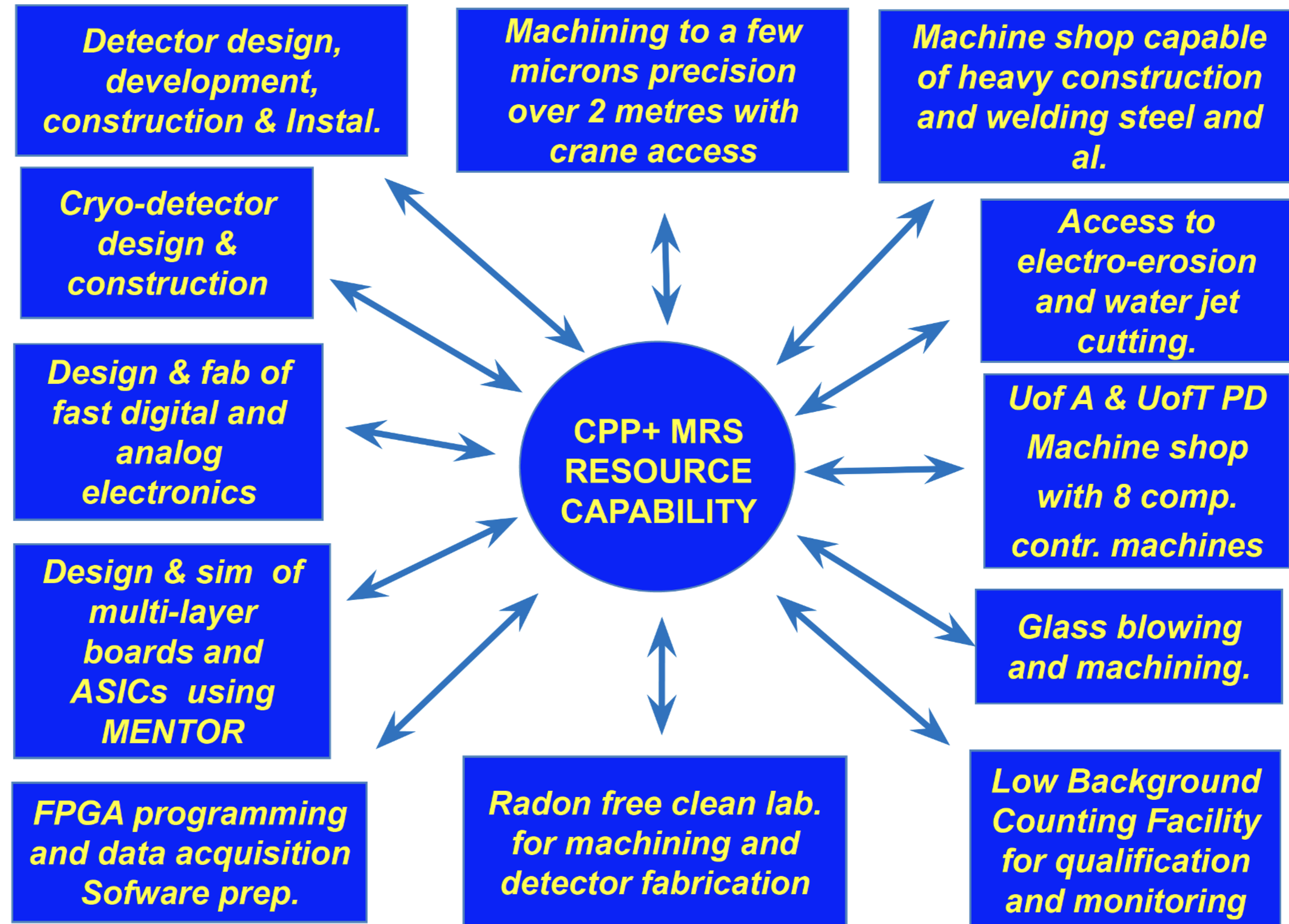

MRS – CPP+ (Alberta) - Contributions

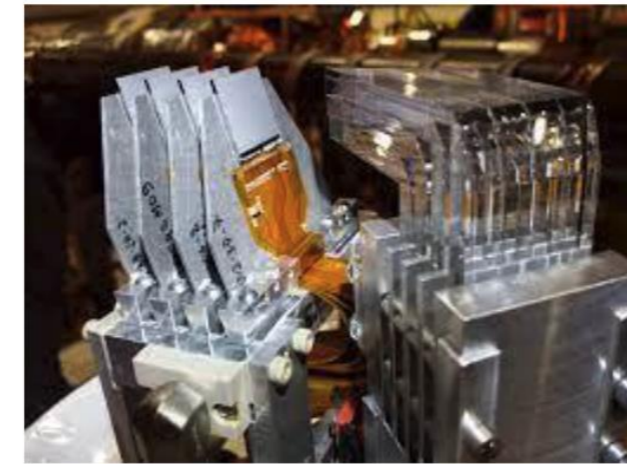

ATLAS AFP

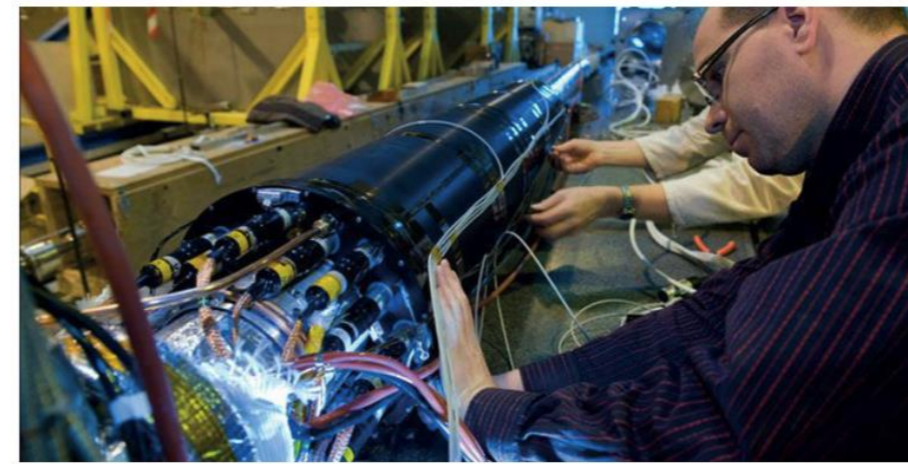

ATLAS LUCID

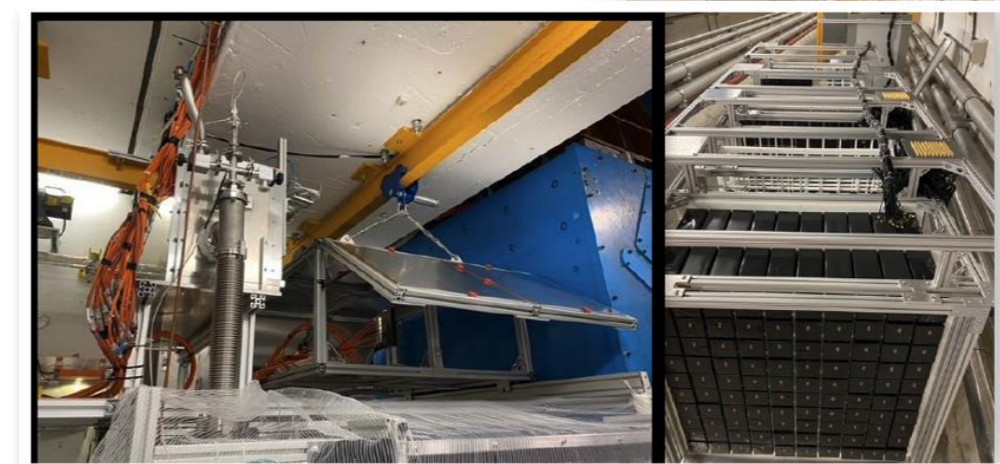

MoEDAL-MAPP



DARKSIDE

1. ATLAS –LUCID
2. ATLAS- AFP
3. DARKSIDE
4. DEAP
5. EIC CAL.
6. HYPER-K
7. MoEDAL-MAPP
8. MATHUSLA (new)
9. nEXO
10. PICO
11. P-ONE
12. SNO+



DEAP



IceCube



MATHUSLA
(starting)



NEWS-G

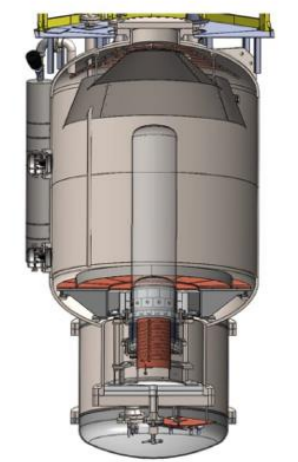

PICO-500

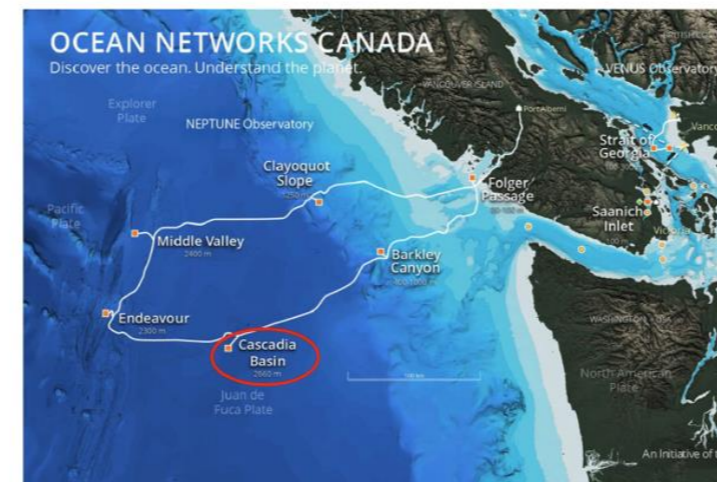

P-ONE (planned,

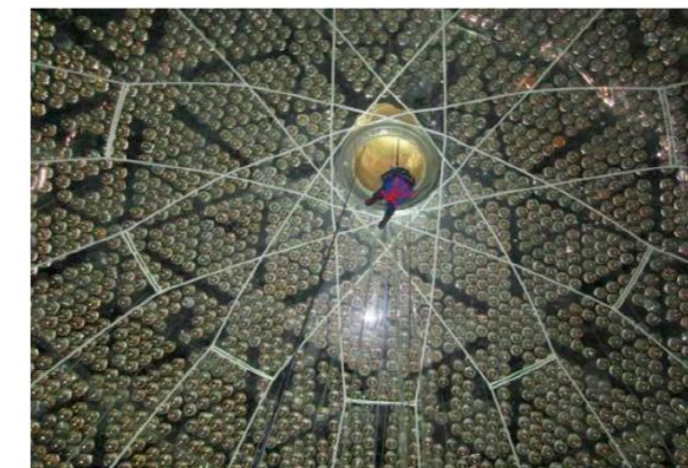

SNO+



SBC

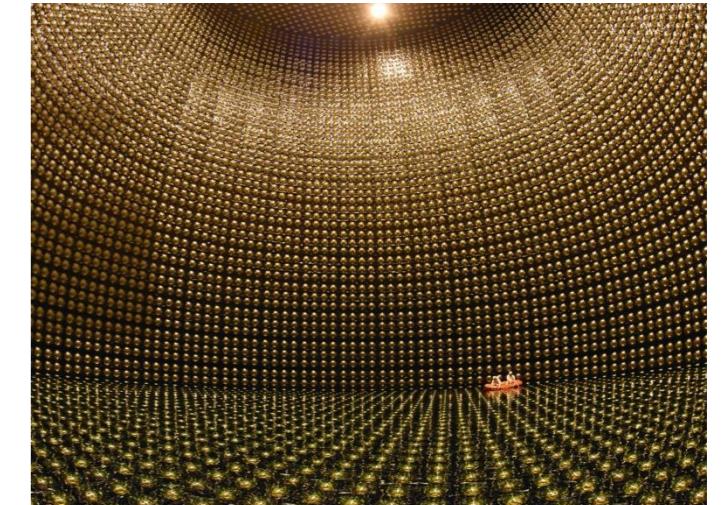

HYPER-K

Carleton Technical Team (MRS Supported)

■ Personnel

- **Electrical Engineer and Electronics Technician**
 - simulation, circuit design, testing, FPGA programming
 - analog and digital readout systems, power supplies, equipment certification
 - soldering, cabling, system modeling, and control
- **Machinist/Technician**
 - precision small parts fabrication, welding, vacuum/gas system cleaning and assembly, leak-checking
 - C&C milling/programming
- **Designer**
 - 3-D modeling, concept development, detailed design drawings for fabrication (e.g., CNC), as-built drawings, FEA calculations

⇒ have worked closely with TRIUMF, McDonald Institute, and SNOLAB engineers

■ Facilities, Equipment, and Expertise

- Machine shop, electronics lab, clean rooms (CNC mill, lathe, water jet, 3D printing, etc.)
- Carleton Science and Technology Centre (STC)
- Cryogenic, vacuum, and gas handling equipment (Swagelok, VCR, Conflat, KF, custom)
- Electronics and DAQ (NIM, VME, LabView, FPGA)
- EUDET silicon pixel telescope
- Department of Electronics CUMFF/FANSSI facility

Select Contributions from the Carleton Technical Team

EXO

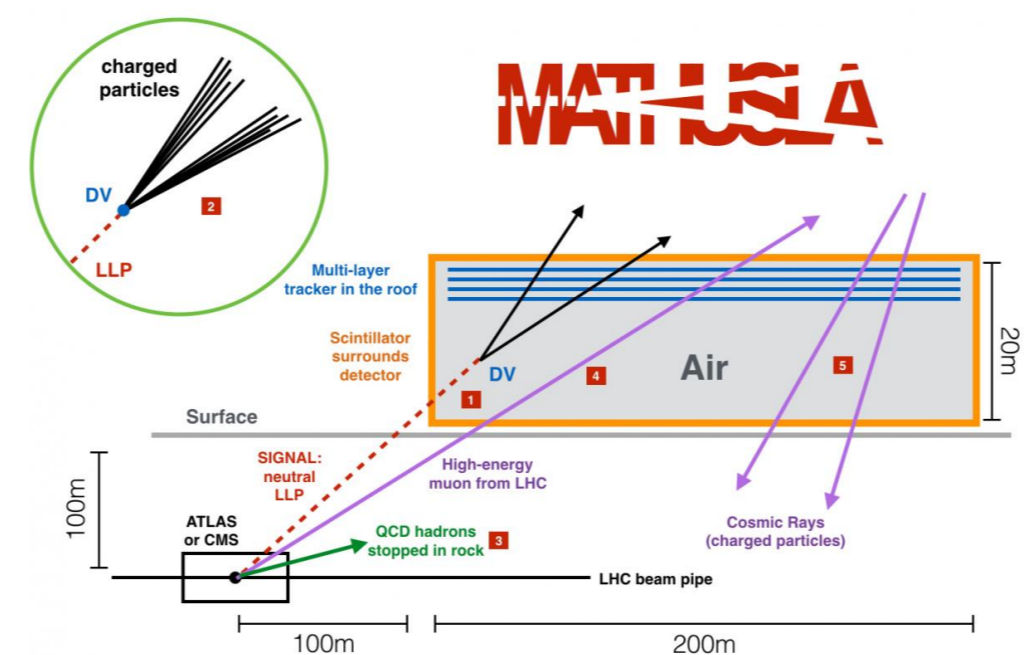
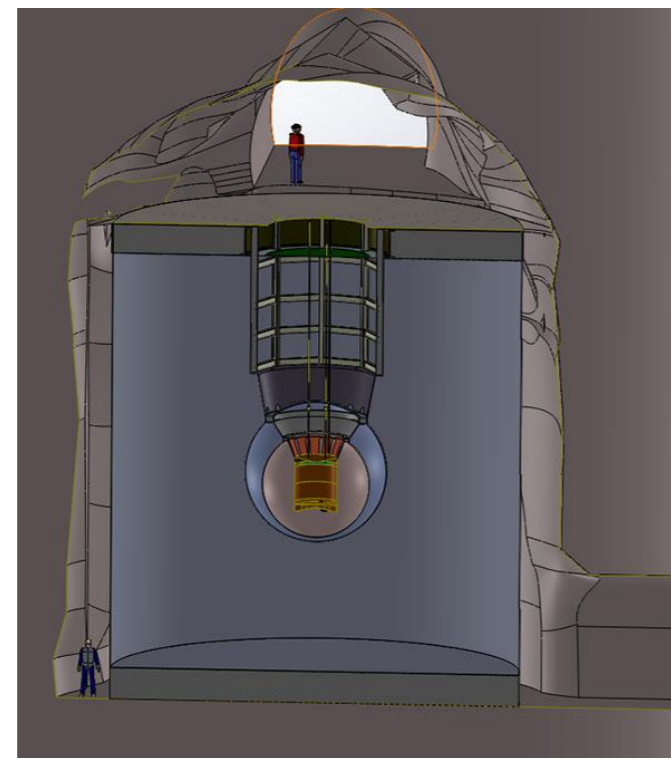

Hyper-Kamiokande

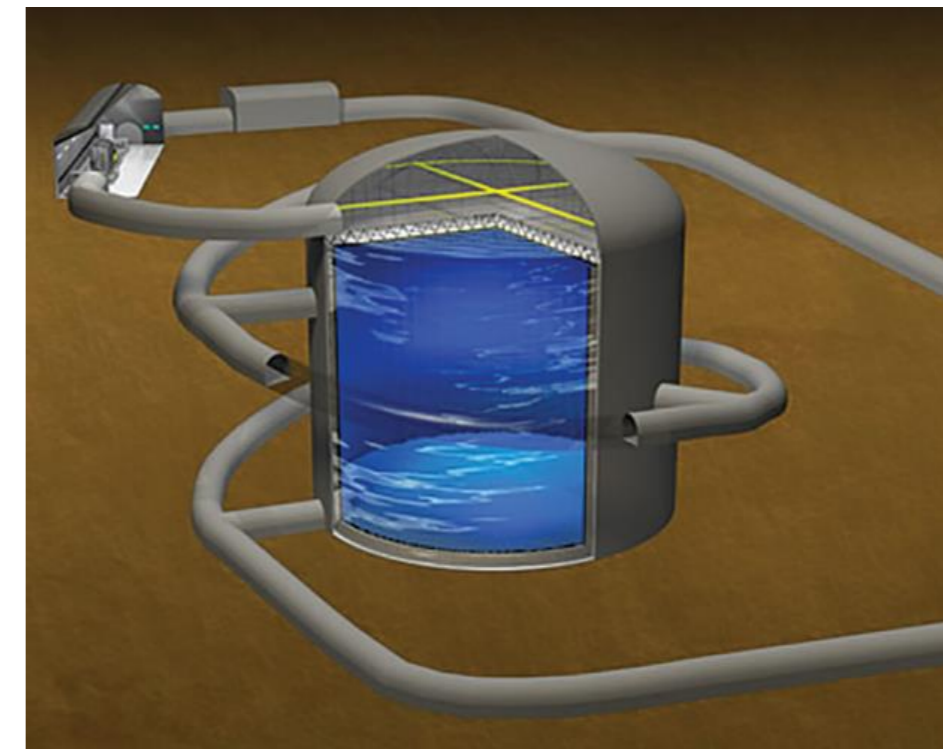

DEAP



For more than 20 years, the Carleton Technical Team has been contributing to subatomic physics via R&D, Testing, Large-Scale Assembly and Delivery, and Maintenance of particle detector systems for a variety of projects in Canada and around the world.

ATLAS-sTGC



ATLAS-ITK

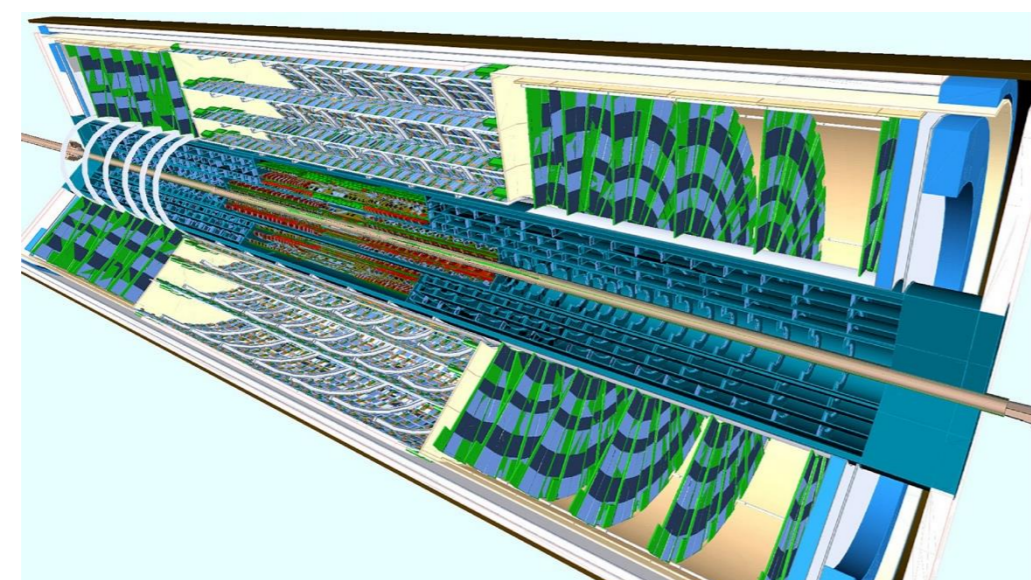

MOLLER

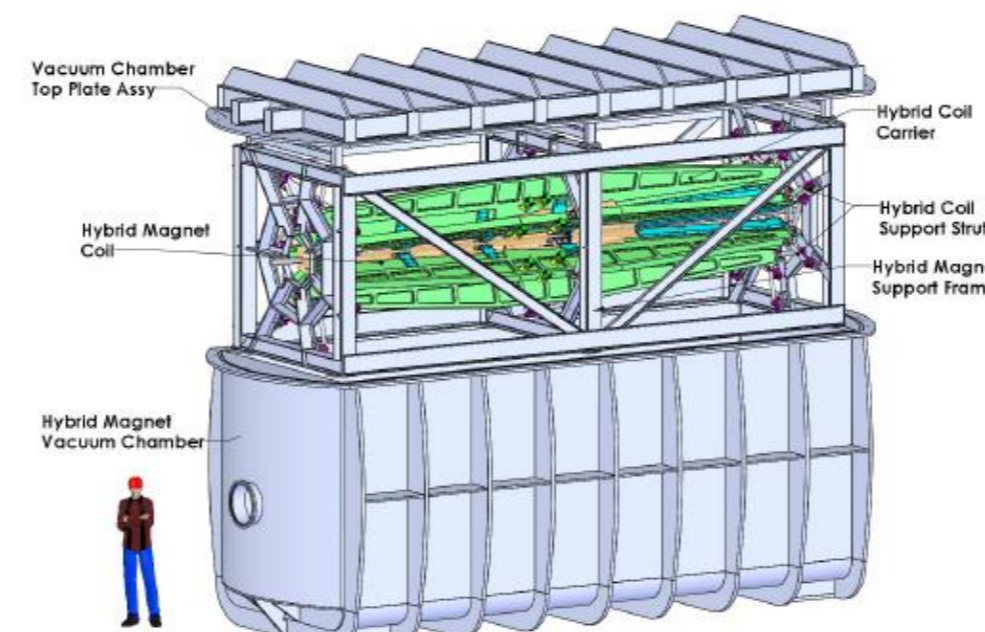

PICO

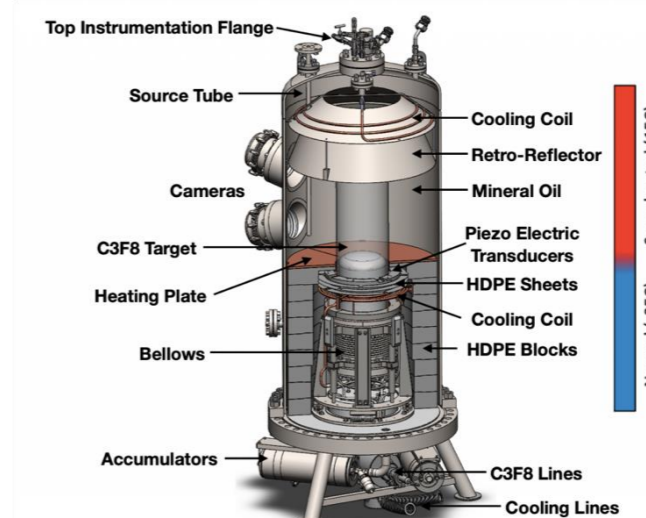

MRS – McGill

- **Resource** : *Firmware engineer specialist*

- **Status:**

- Person identified and in final stage of work permit approval (in ~ 1 month).
 - M.Tech. Microelectronics and VLSI Design, M.Sc. Physics, B.Sc. Physics/Computer Science
 - Currently working on CMS L1 Calorimeter Trigger upgrade for HL-LHC
- Aim to have resource available to community ~ September.

- **Support to be provided :**

- Consultancy in high-level design of complex firmware projects.
- Firmware design and implementation in highly integrated readouts of state-of-the-art sensors.
- Firmware implementation of machine learning algorithms in large-scale FPGA-based embedded systems.
- Expertise in firmware implementation of interfaces to generalized readout components developed for subatomic physics research (e.g. FELIX).
- Hardware-specific firmware optimization.

Montréal MRS Resource: the Laboratoire Technologique Avancé (LTA)

- At the Laboratoire René J.-A. Lévesque, UdeM — rooted in the 1966 Nuclear Physics Laboratory
- Groupe technologique — electronics lab (H. Cao, W.C. Chao, C. Drancourt, N Starinsky)
 - Detector readout, FPGA firmware, DAQ, slow control, embedded software
- Machine shop (Tomy Arial)
 - High-precision machining (to 0.0005"), vacuum & cryogenic welding, custom fabrication
- Ion beams facility — 6 MV Pelletron Tandem
 - Protons to 11 MeV (15 μ A); mono-energetic neutron beam (keV) for dark-matter calibration

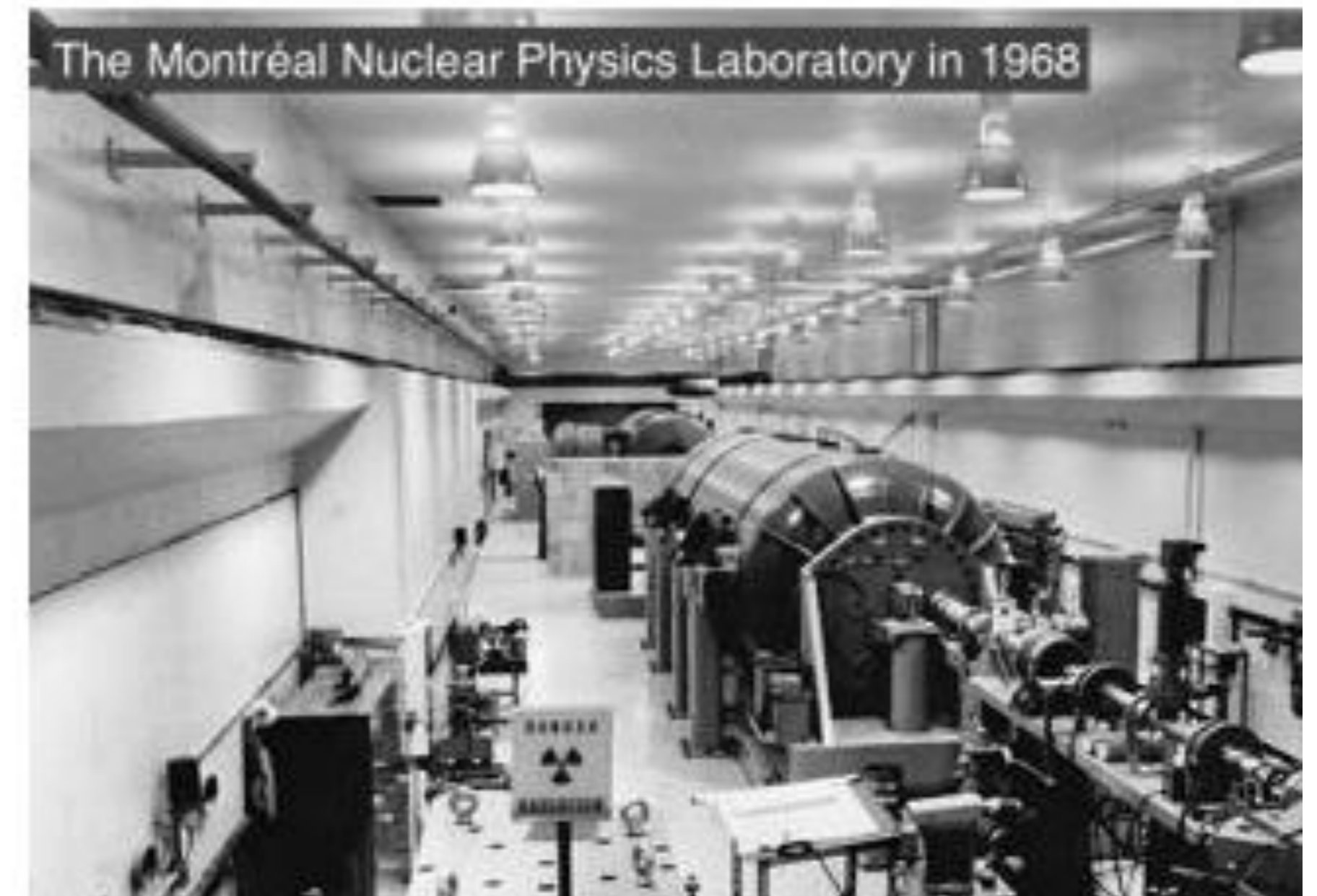

6 MV Pelletron Tandem — the first commercial Tandem prototype; Chalk River 1954 → UdeM 1966

Strong institutional support: just submitted a CFI JELF grant request for ~750k\$ of new equipment

Example UdeM-LTA success stories: serving the community at no cost to users

- Electronics: DUNE experiment
 - Wrote the firmware for the FPGA-based Timing System (clock-phase precision to 10 ps)
 - Writing the core software for the Data Filter — core to the trigger/DAQ
- Machine shop: TUCAN ultracold-neutron experiment
 - Machine shop delivered a precise, critical flange for the Fall 2024 science run — essential to the run and to securing future funding
- Beamline: NEWS-G dark-matter search
 - Calibrated with the facility's mono-energetic neutron beam (Fall 2025)
- Other recent users: ATLAS (ITk and LAr), PICO / PICO-500, SBC, nEXO, SuperCDMS, DarkSide-20k, Hyper-K, Belle-II, barium tagging, Project X17, Timepix / TPX

In conclusion

- **MRS technical resources: hubs of expertise to design and build SAP experiments with personpower free of charge**
- **Submit your request through the CINP or IPP webpages!**
 - <https://cinp.ca/subatomic-physics-major-resources-support-facilities>
 - <https://particlephysics.ca/community/major-resources/>
 - Don't hesitate to contact the [MRS board](#) if you have any questions