



# RESEARCH SCIENTIST ACTIVITIES REPORT

Alex Wright

Institute of Particle Physics/  
Queen's University

IPP AGM 2026

# Self Introduction

- IPP Research Scientist since 2012
- Based at Queen's University
- Research Area: Particle Astrophysics
  - Ph.D. on the Sudbury Neutrino Observatory (2009)
  - Dicke Fellow at Princeton (2009-2012) working on the Borexino and DarkSide experiments
- Main research efforts: SNO+ and SBC

# SNO+

- 780 tonnes of liquid scintillator
- 12m diameter acrylic vessel
- 1500 + 5300 tons ultra-pure water shielding
- ~9500 PMTs
- 6800' underground in SNOLAB

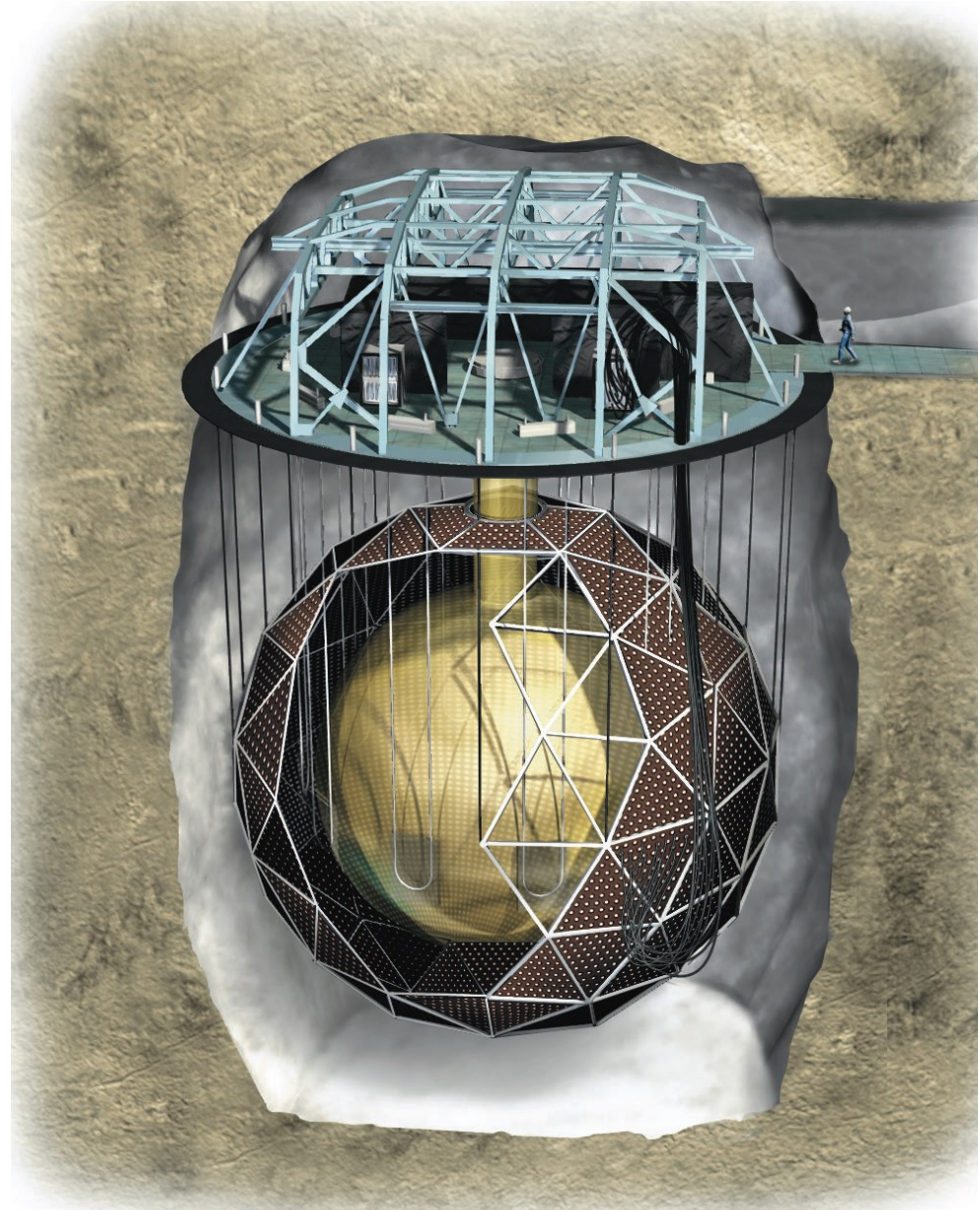

# SNO+ Physics

## Neutrinoless Double Beta Decay

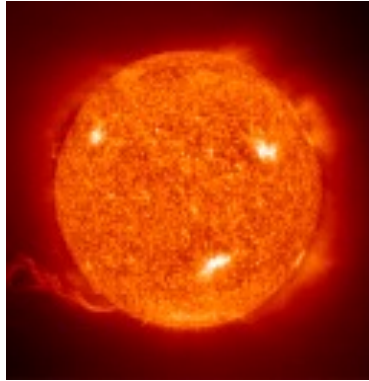
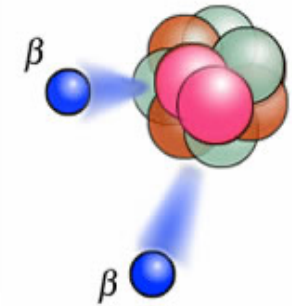

**Solar Neutrinos**

**Reactor Antineutrinos**



**Geo-Neutrinos**

**Supernova Neutrinos**

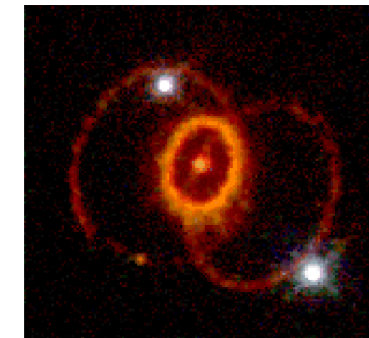

**“Exotic” physics**

# SNO+ Timeline

Water Phase

2017 – 2019



905T ultra-pure water



“Partial-fill” Phase

2019 – 2022



Half replaced with liquid  
scintillator (COVID19  
pause)



Scintillator Phase

2022 – ongoing

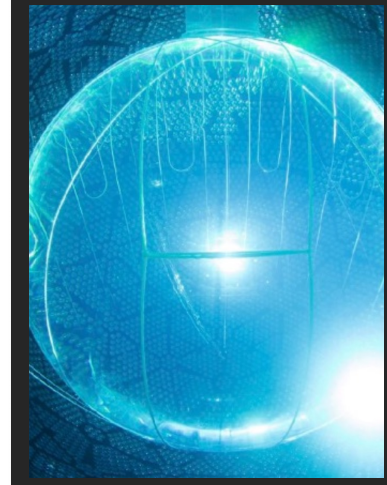

780 T liquid scintillator



Tellurium Phase  
Search for  $0\nu\beta\beta$

# SNO+ Science Results

## Water phase:

- [Measurement of the  \$^8\text{B}\$  solar neutrino flux with very low backgrounds \(x2\)](#)
- [First efficient detection of neutron captures by a pure water detector](#)
- [First measurement of reactor antineutrinos by a water Cherenkov detector](#)
- [World-leading limits on “invisible” nucleon decay \(x2\)](#)
- [Measurement of cosmogenic neutron production](#)

## Partial-fill:

- [First event-by-event direction reconstruction in a high light-yield liquid scintillator](#)
- [Initial measurement of reactor antineutrino oscillation at SNO+](#)

## Scintillator phase:

- [First evidence of solar neutrino interactions on  \$^{13}\text{C}\$](#)
- [Measurement of reactor antineutrino oscillation at SNO+ \(0.29 ktonne-years\)](#)
- Preprint: [Measurement of reactor antineutrino oscillations with 1.46 ktonne-years of data at SNO+](#)

# SNO+ Status & Plans

- SNO+ is currently shut down for maintenance
  - A small leak near the top of the acrylic vessel was identified in 2025
  - Currently draining to repair the leak
  - Target repair by Nov 2026
- After refilling, recirculate/strip the scintillator
- Targeting Te loading fall 2027

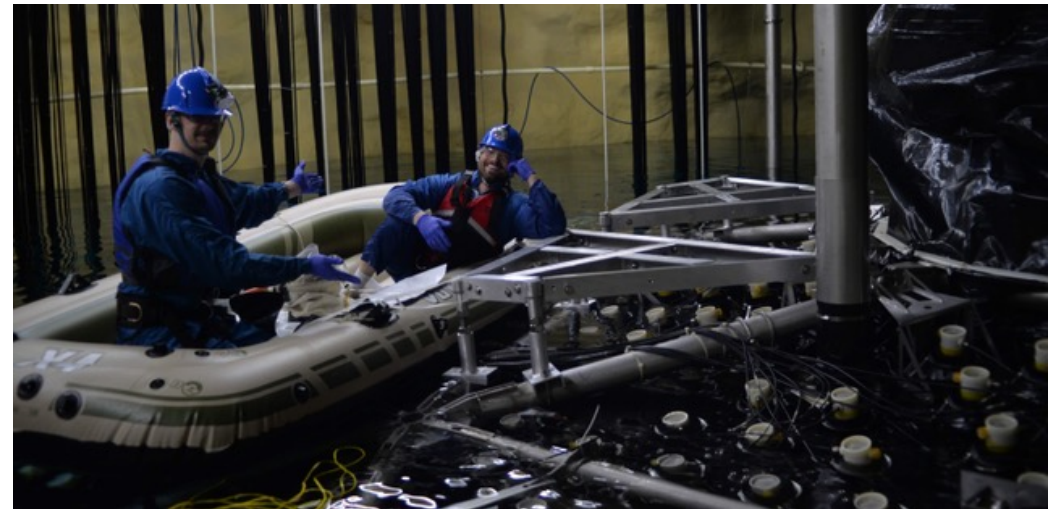
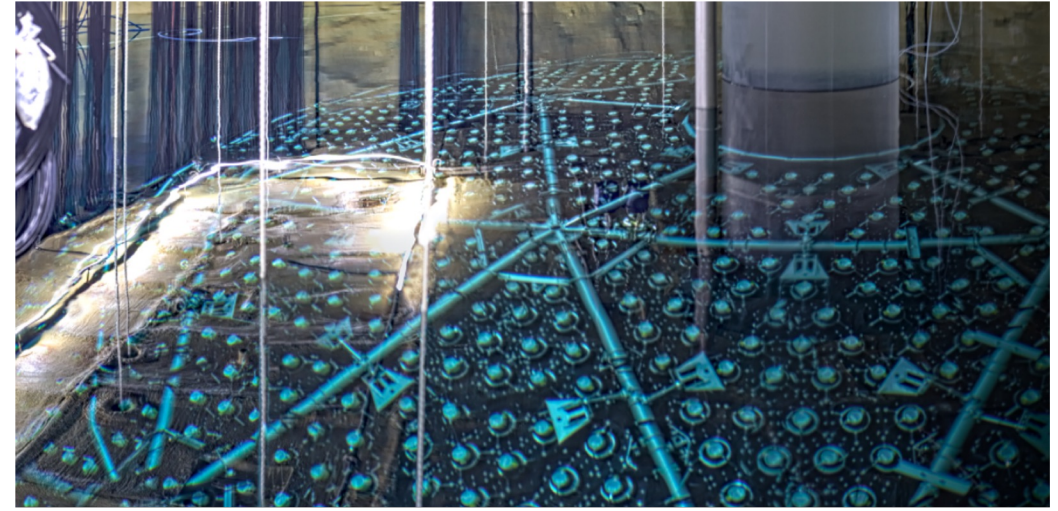

# SNO+ Contributions

- Administrative
  - Chair of the Collaboration Board & Executive Committee
  - Member of the “Mid-Level Group” (~ a Steering Committee)
- Science
  - Co-convene the Solar Neutrino analysis group
  - HQP have made important contributions to most SNO+ publications; lead author/analyst for three
  - HQP lead processing and data cleaning working groups

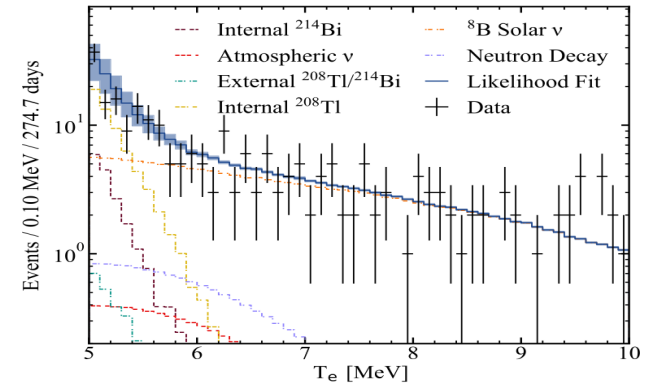

Brian Krar: Phys. Rev. D **110**, 122003 (2024)

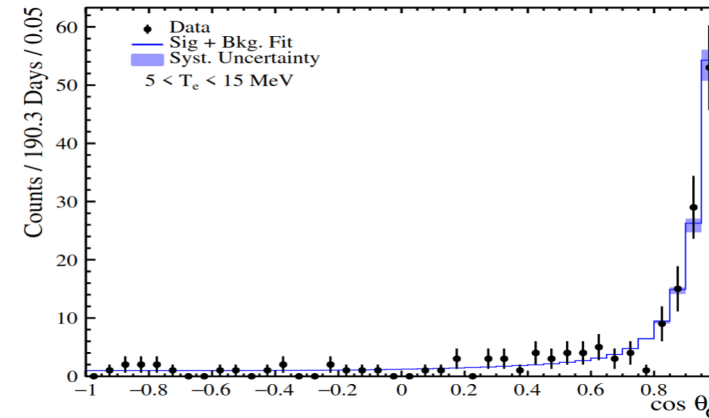

James Page: arXiv:2511.11856

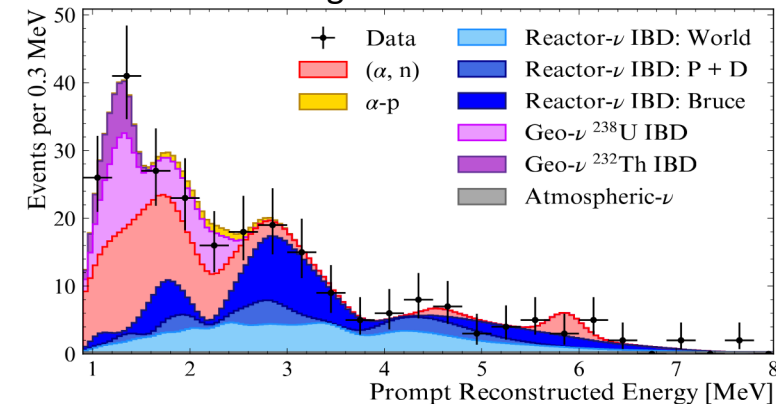

# SNO+ Contributions

- Technical
  - Led the design and installation of the tellurium process systems
  - SNO+ science lead on the SNOLAB ultra-pure water and lead the SNO+ water assay group
  - Member, and past chair, of the SNO+ calibration source review committee
  - Detector calibration including production of calibration components; HQP leading calibration analysis
  - “Problem solving” – design/construct alternate method of removing water during scintillator fill; “roboshifter”; system to pre-tension hold-down ropes; design/construct access platforms for AV repair work

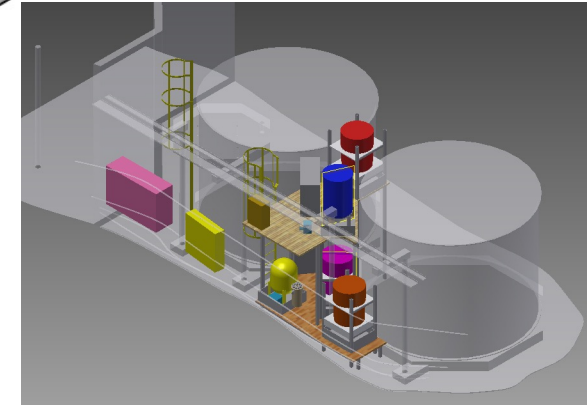
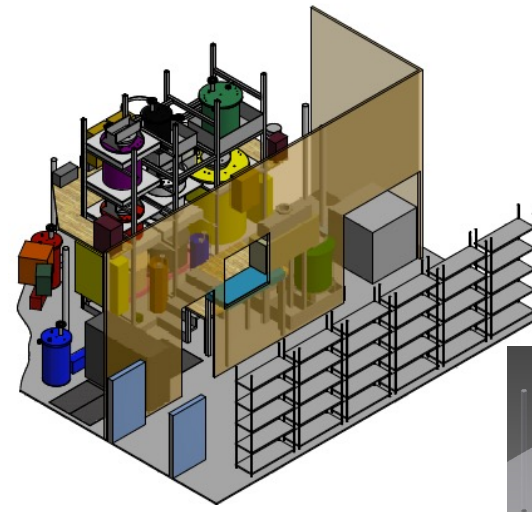

# The Scintillating Bubble Chamber Experiment

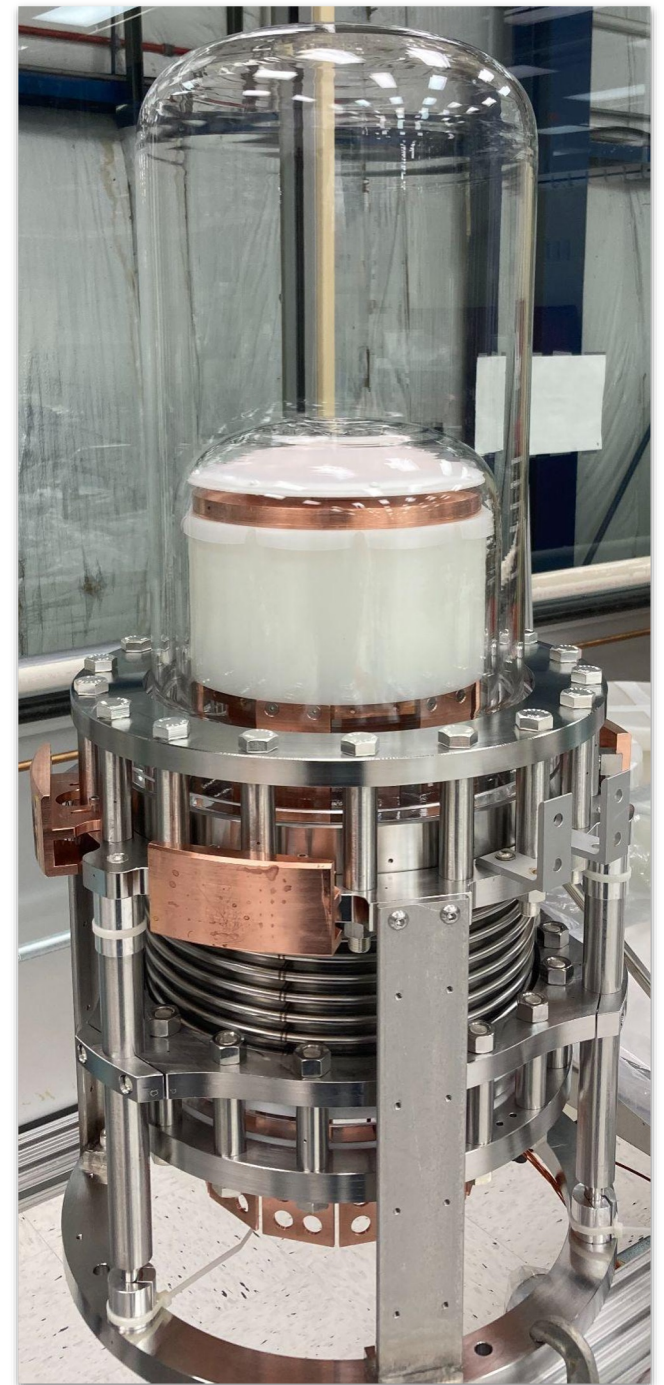

# Bubble chambers for DM searches

- Superheated liquids have efficient bubble formation at low n.r. thresholds
- Can operate in highly  $\beta/\gamma$  insensitive regimes
  - For low mass WIMP searches, the onset of e.r. sensitivity determines the lowest achievable n.r. thresholds.
- In SBC, bubble formation is suppressed by the emission of argon scintillation light. More efficient scintillation for e.r.'s lowers e.r. bubble formation threshold relative to the n.r. threshold, allowing lower WIMP masses to be probed

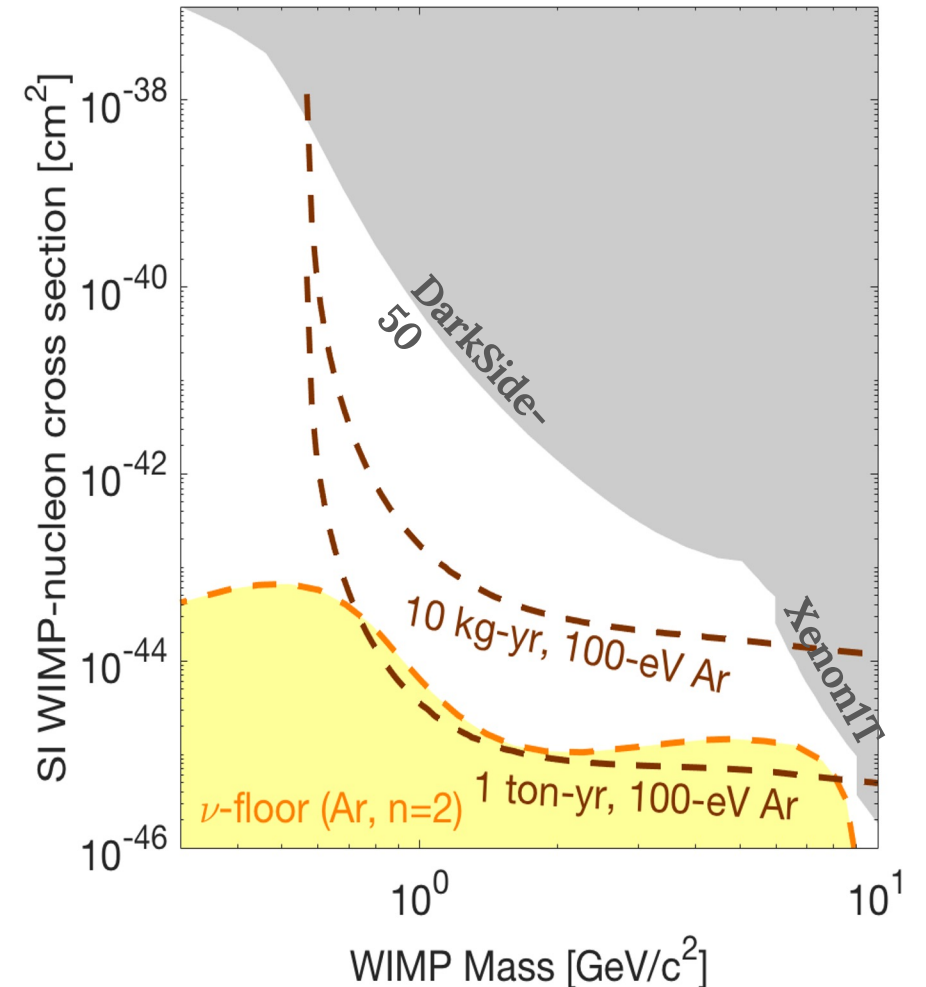

# SBC 10 kg detectors

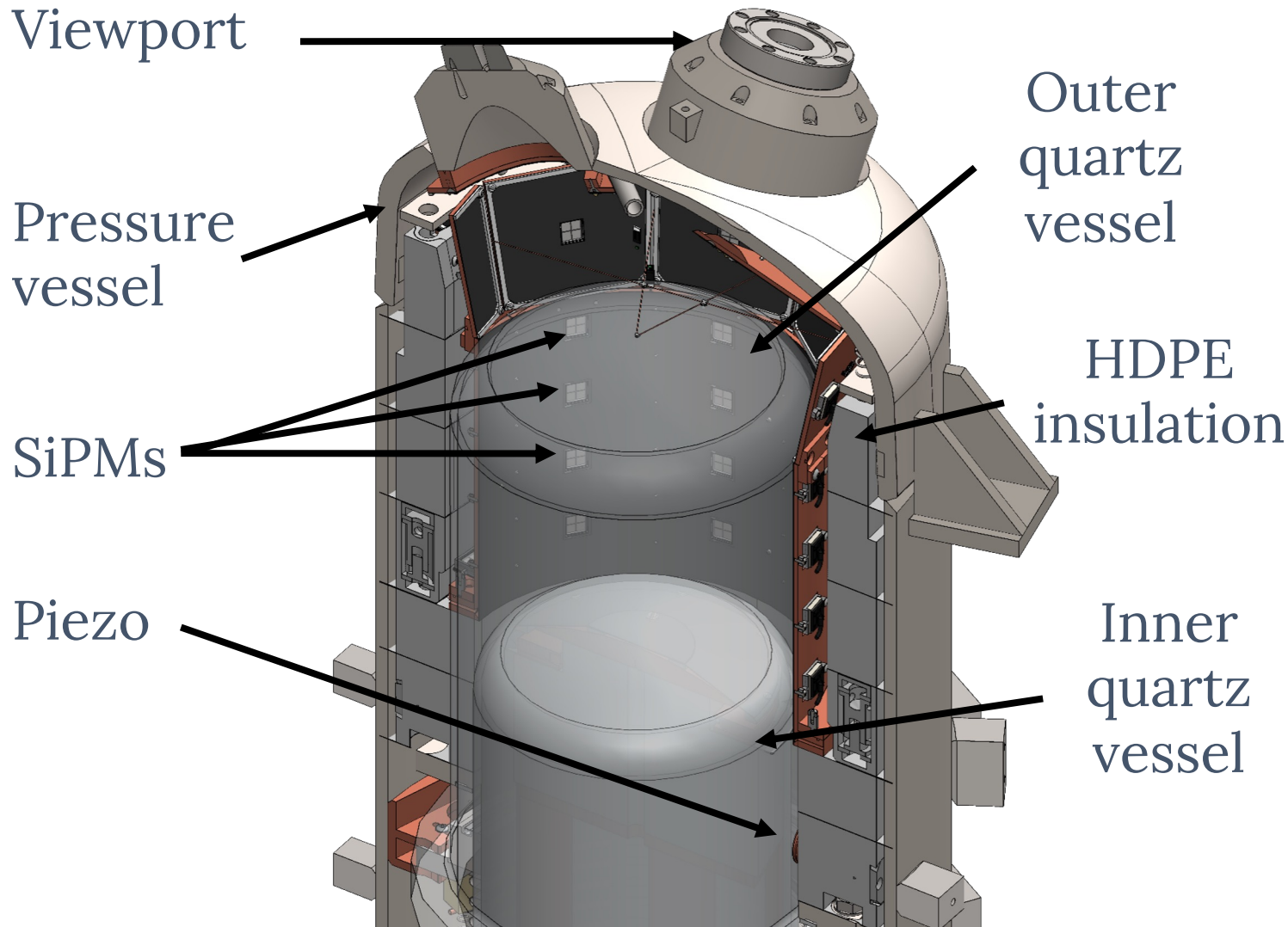

Two functionally identical detectors:

**SBC-LAr10 @ Fermilab**  
(engineering, calibration,  
future CE $\nu$ NS program)

**SBC-SNOLAB @ SNOLAB**  
(low background  
dark matter search)

# SBC at FNAL

- 6 months of stable operation with nucleation thresholds from 0.46 – 3 keV
- Simultaneous measurement of scintillation and bubble nucleation observed

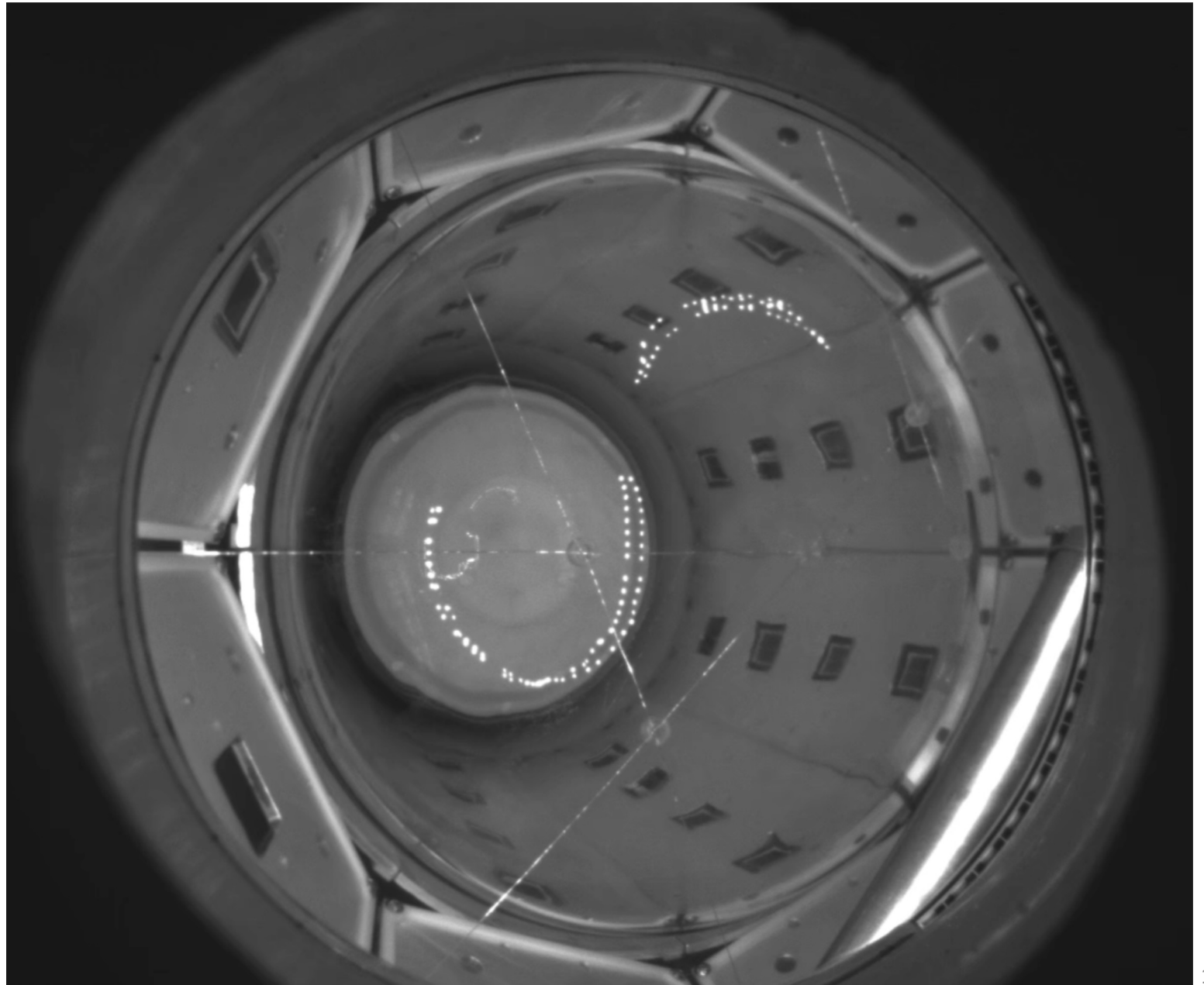

# SBC at FNAL

- 6 months of stable operation with nucleation thresholds from 0.46 – 3 keV
- Simultaneous measurement of scintillation and bubble nucleation observed

[link](#)

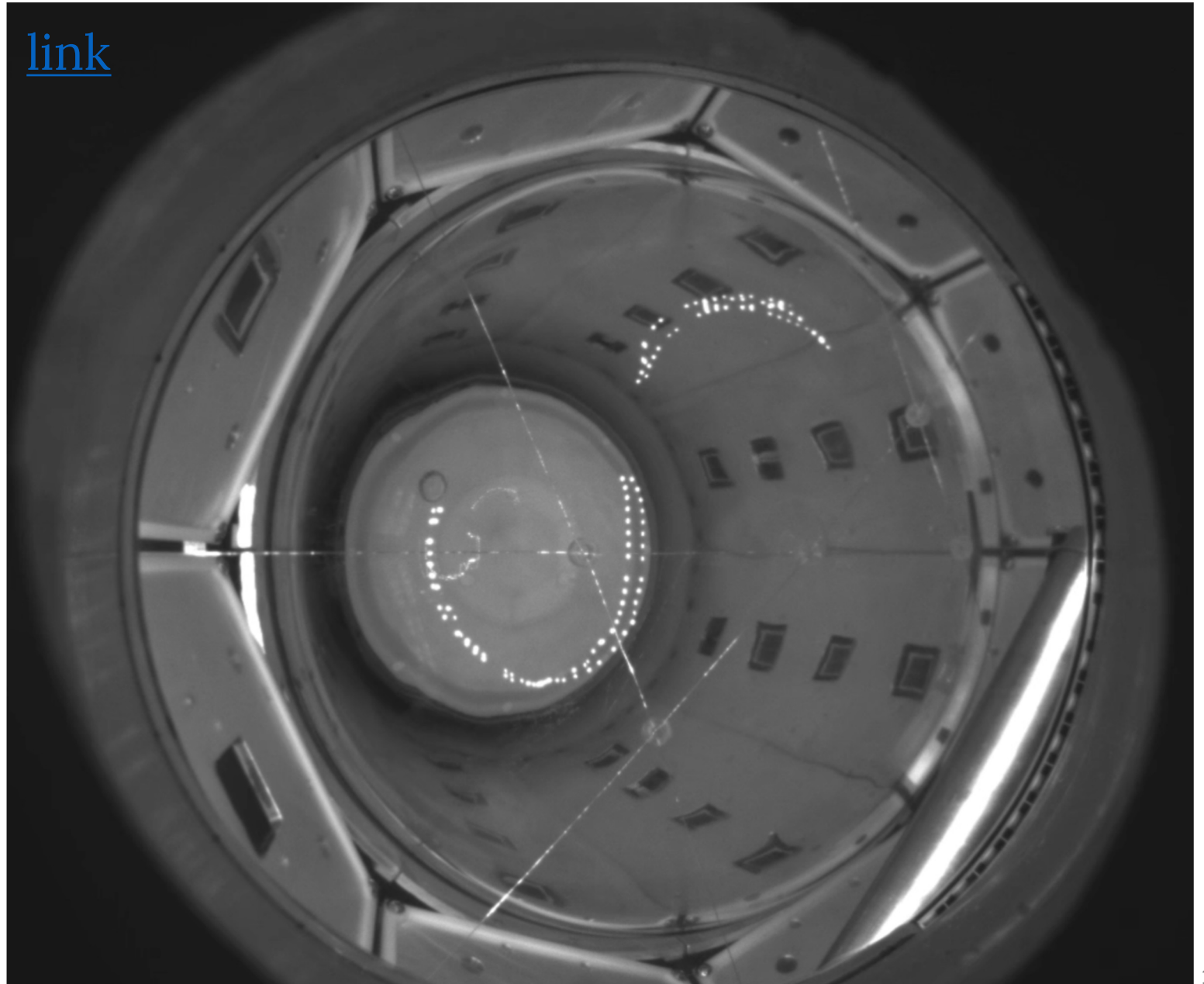

# SBC at FNAL

- 6 months of stable operation with nucleation thresholds from 0.46 – 3 keV
- Simultaneous measurement of scintillation and bubble nucleation observed

[link](#)

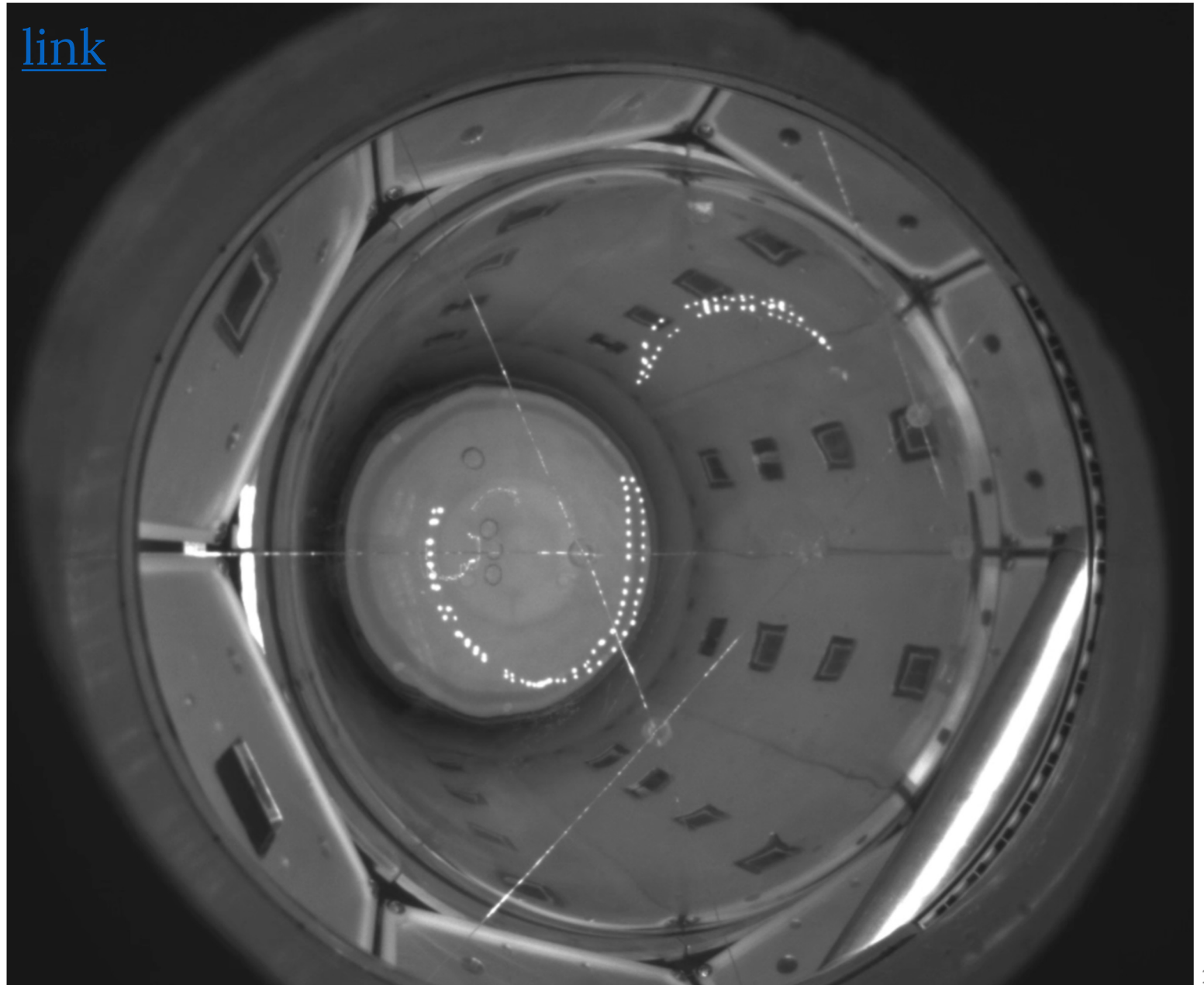

# SBC-SNOLAB

- Design and material selection complete
  - Full assay campaign and Geant4 simulation of internal and external backgrounds
- Major components in-hand
- Space allocated in the ladder labs at SNOLAB
- SNOLAB GW II review recently completed
- Installation this fall

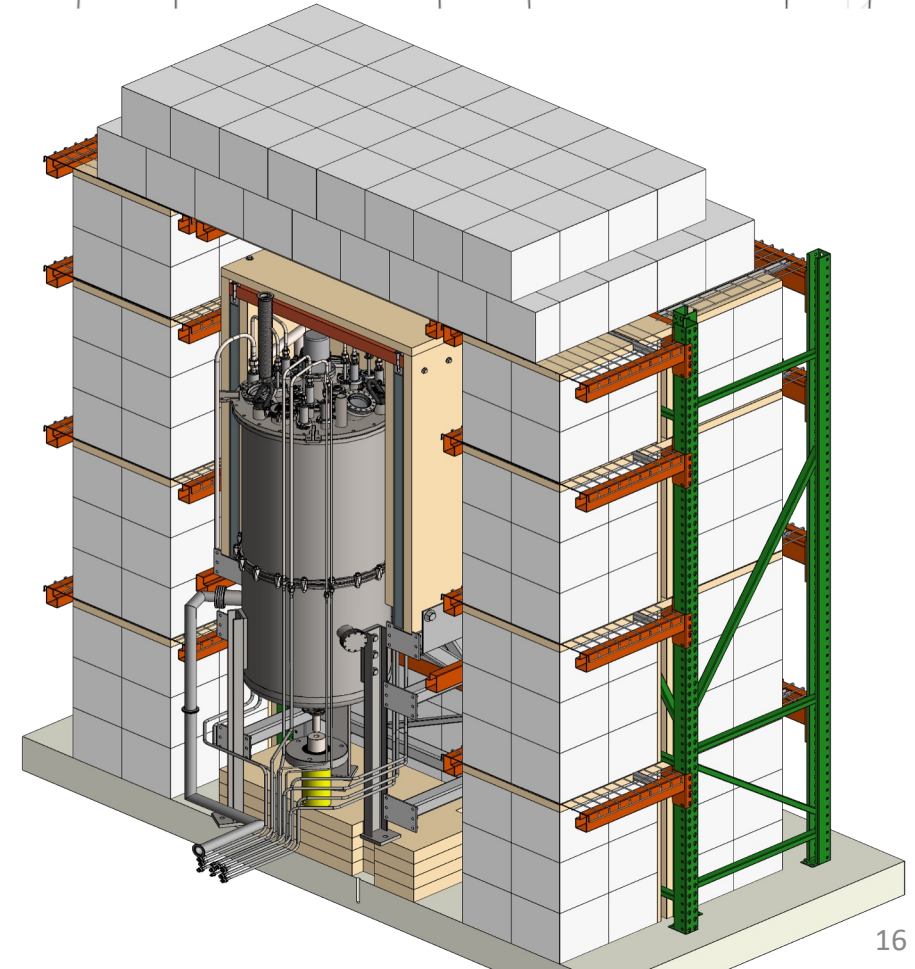
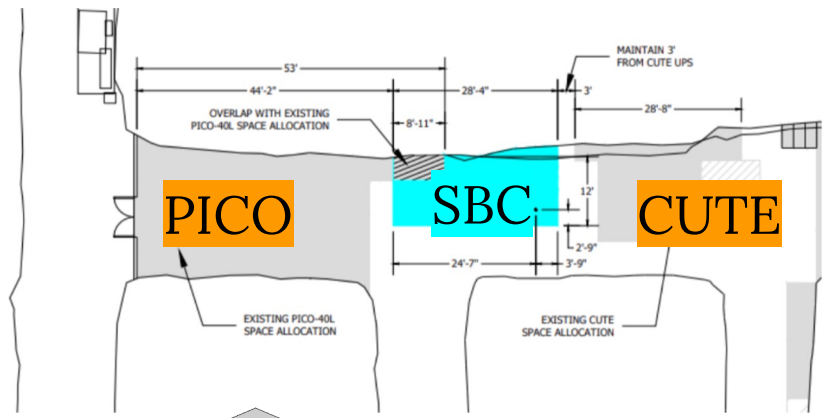
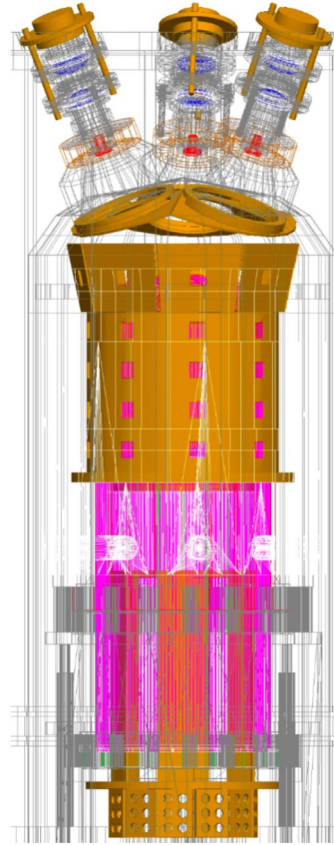

# SBC Contributions

- Backgrounds
  - Radiopurity screening/background simulations
- Molecular dynamics studies of bubble nucleation with scintillation

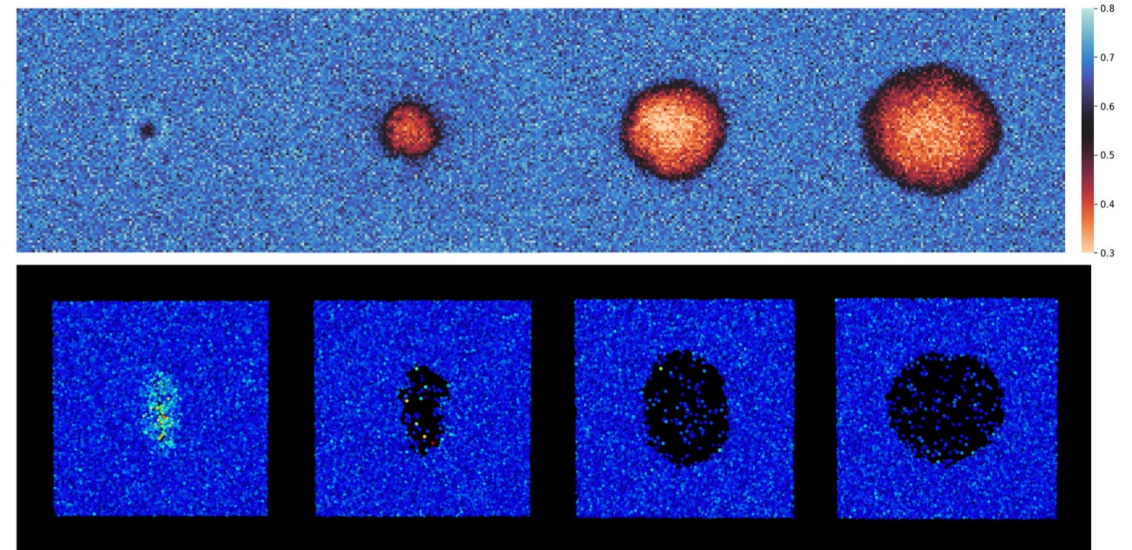
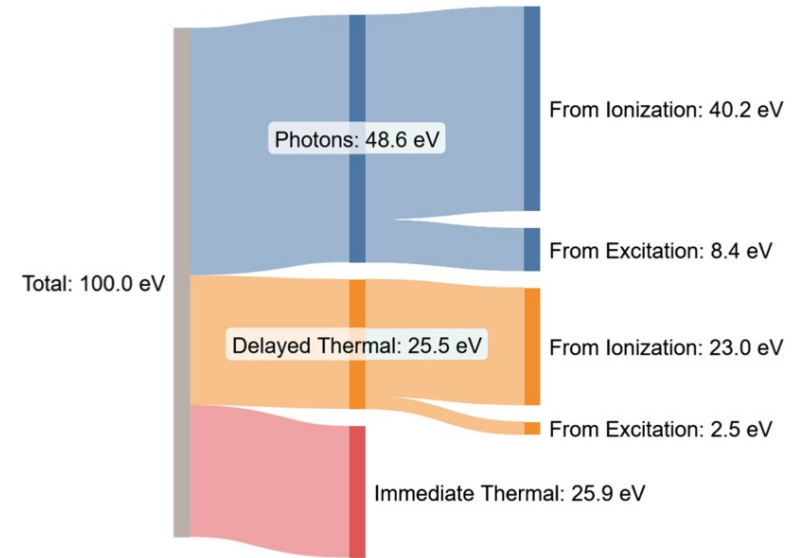

# Other Contributions

- Community Service
  - Technical engagements with possible future projects (nEXO, THEIA, XLZD)
  - IPP Secretary (since 2025)
  - SAPES (2021-23)
  - 2022 LRP committee
- Supervision
  - 12 grad students, 62 undergrads, 4 postdocs, 6 engineers/EITs, 5 technical staff since 2012
- Outreach
  - Science Rendezvous
  - Frontenac Lennox & Addington Science Fair

