

Opportunities in Calorimetry

CAP Congress FCC Discussions

Max Swiatlowski

TRIUMF



Introduction



DRDCalo

- Huge amount of work in calorimeter R&D ongoing in DRDCalo (DRD6)
 - Details in April 2026 workshop
- Not a huge Canadian engagement thus far
- Today: what I see as opportunities for Canadian engagement

Calorimeters in Canada

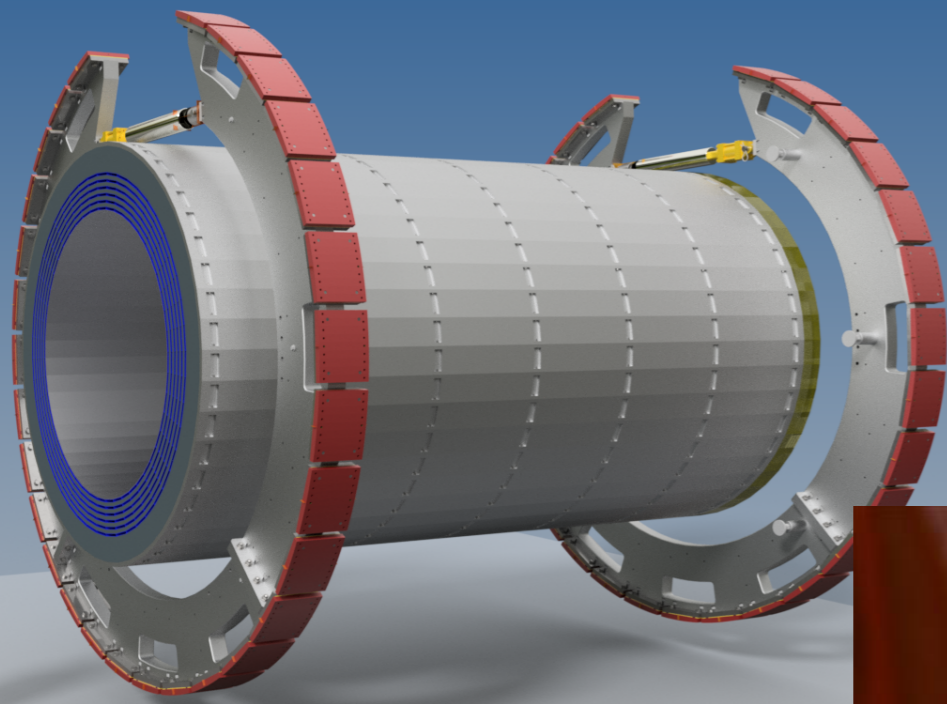

EPIC: MAPS



ATLAS: LAr

CALICE: Tile+SiPM

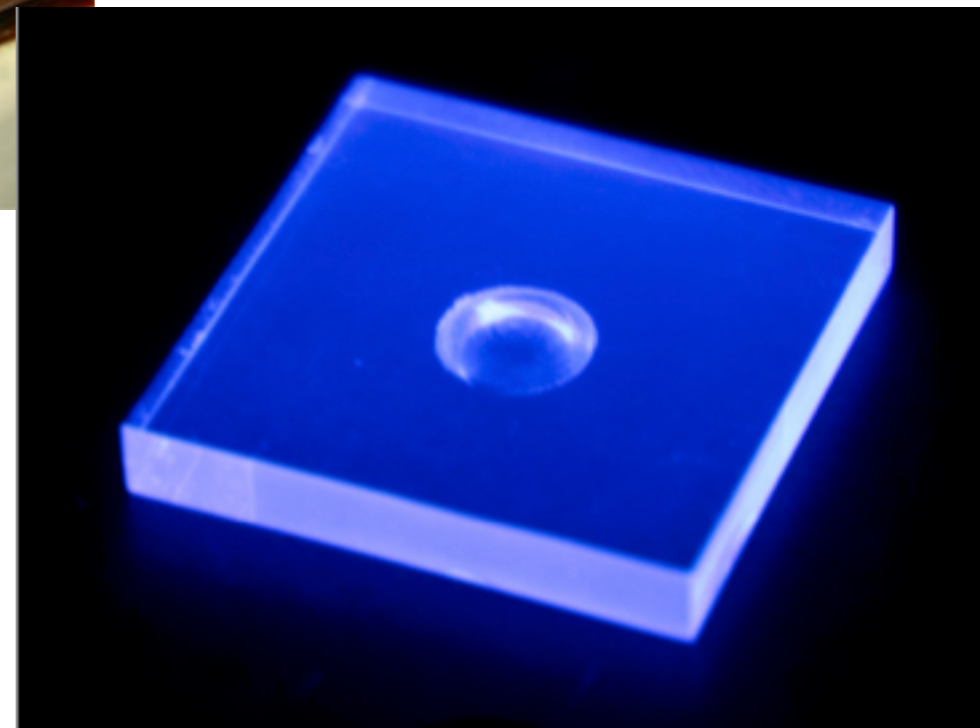

Calorimeters in FCC



FCC-ee Proposed Detector Concepts Overview

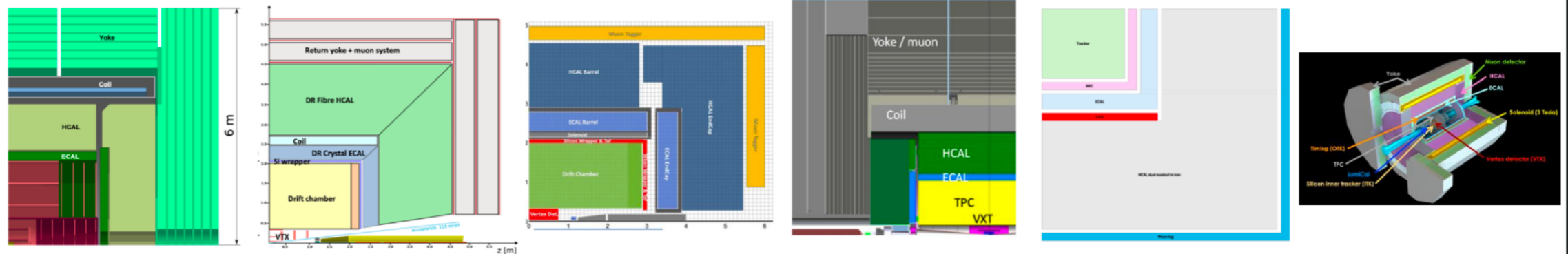

CLD

IDEA

ALLEGRO

ILD

ALFA
emerging

AGORA
from CEPC, new for FCC-ee

	CLD	IDEA	ALLEGRO	ILD	ALFA emerging	AGORA from CEPC, new for FCC-ee
Vertex	Si	MAPS (ITS-3 like)	MAPS (ITS-3 like)	Si	MAPS (ITS-3 like)	MAPS
Tracker	Full Si	Drift Chamber + Si strp	DCH / Straw / SciFi + Si	TPC + Si strips	All MAPS	TPC + Si strips
ECAL	Si-W highly granular	Crystals w. DR	Noble Liquid (LAr)	Si-W highly granular	Granita (crystal grains)	Crystals
HCAL	Scint. sampling	Fibre DR	TileCal (steel/scint.)	Scint. or RPC	DR + steel	Glass scint. + steel
Muon	RPC in iron yoke	μ RWELL	TBD	Scint. in iron yoke	TBD	Scint. in yoke
PID	RICH (option)	tracker dN/dx (+ TOF)	tracker dN/dx (+ TOF)	tracker dN/dx (+ TOF)	Cherenkov ARC	tracker dN/dx (+ TOF)
Coil B-field	Outside HCAL 2T	Inside HCAL 2T (3T HTS R&D)	Inside HCAL 2T	Outside HCAL 3.5 T -> 2-3 T	Inside HCAL 3T	Outside HCAL 3T



CALICE - Analog Hadronic Calorimeter

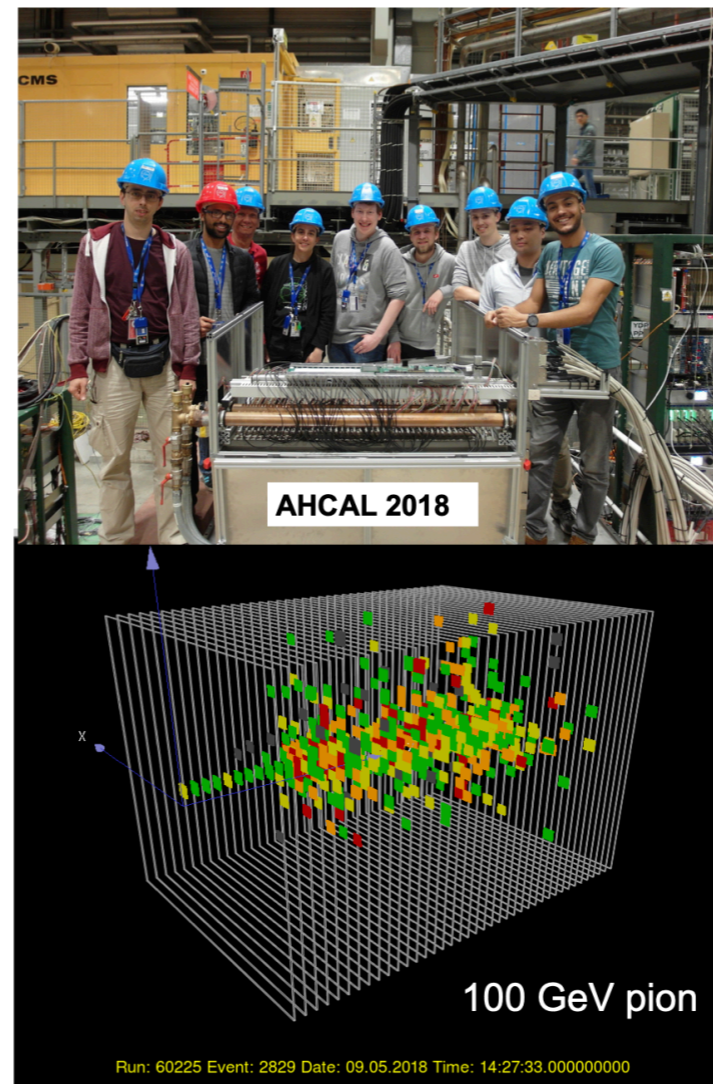

38 layers
 $72 \times 72 \times 2.5 \text{ cm}^3$ / layer
22,000 tiles

SiPM under the tiles
for better uniformity
and light collection

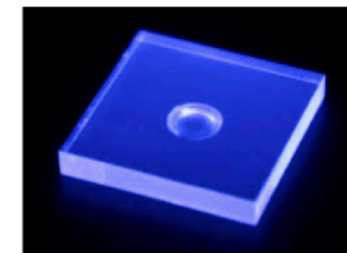

each cell also provides
time information with
 $\sim 1 \text{ ns}$ resolution

a true 5D “pixel”
detector: x, y, z, E, t

Francois Corriveau

More on HCal



- Allegro adopting similar approach, but utilizing wavelength shifting fibres
 - Still SiPM for readout
- Also exploring SPAD for readout of fibres: synergy with DRD4/Fabrice
- More info from CALOR talk, Mattia Soldani

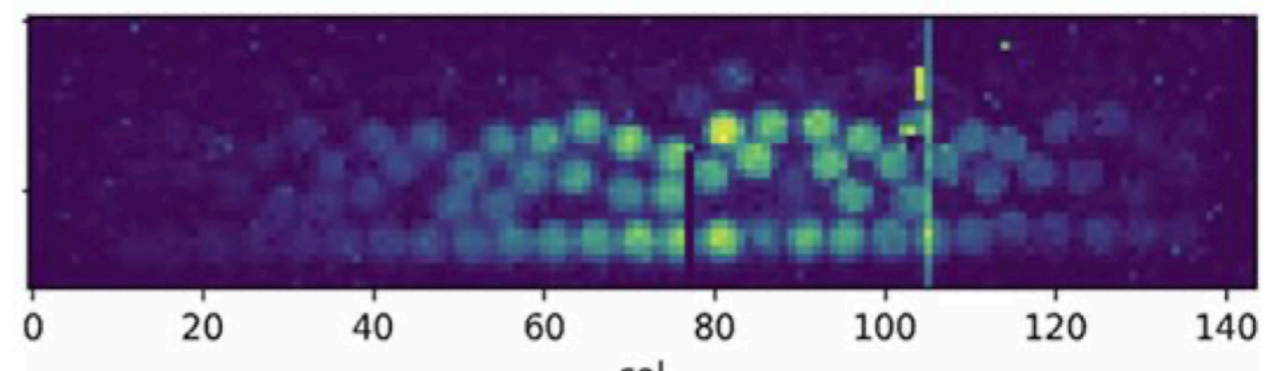
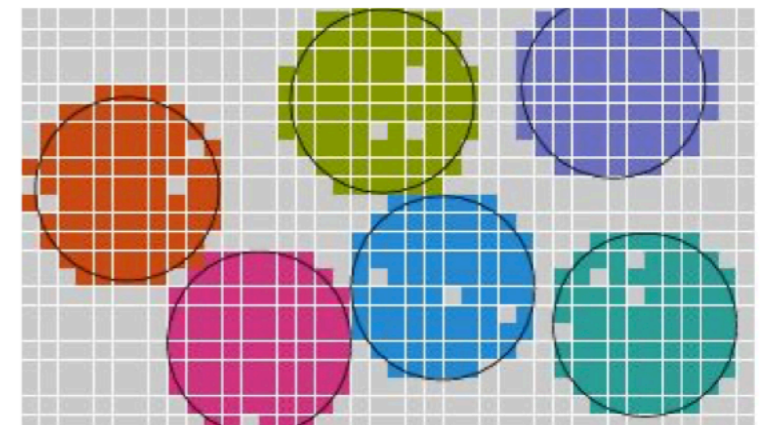
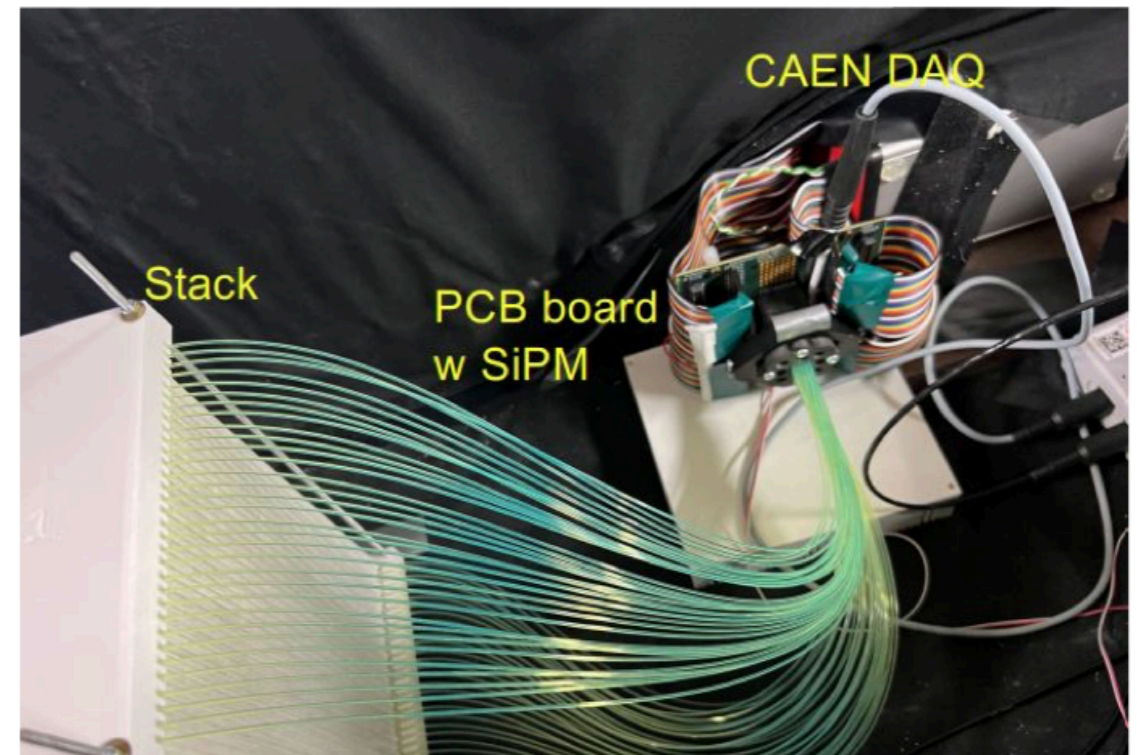

Thoughts



- Good synergy with DRD4/Fabrice ✓
- Continue ATLAS experience with similar (but improved) technology ✓
- No exciting Canadian effort ✗
- But a great project if there is interest...!

Liquid Argon in ATLAS



- ECal, Hadronic Endcap, and FCal all based on LAr
- Canada built HEC and FCAL sections
- Currently involved in electronics and readout upgrades for Phase 2

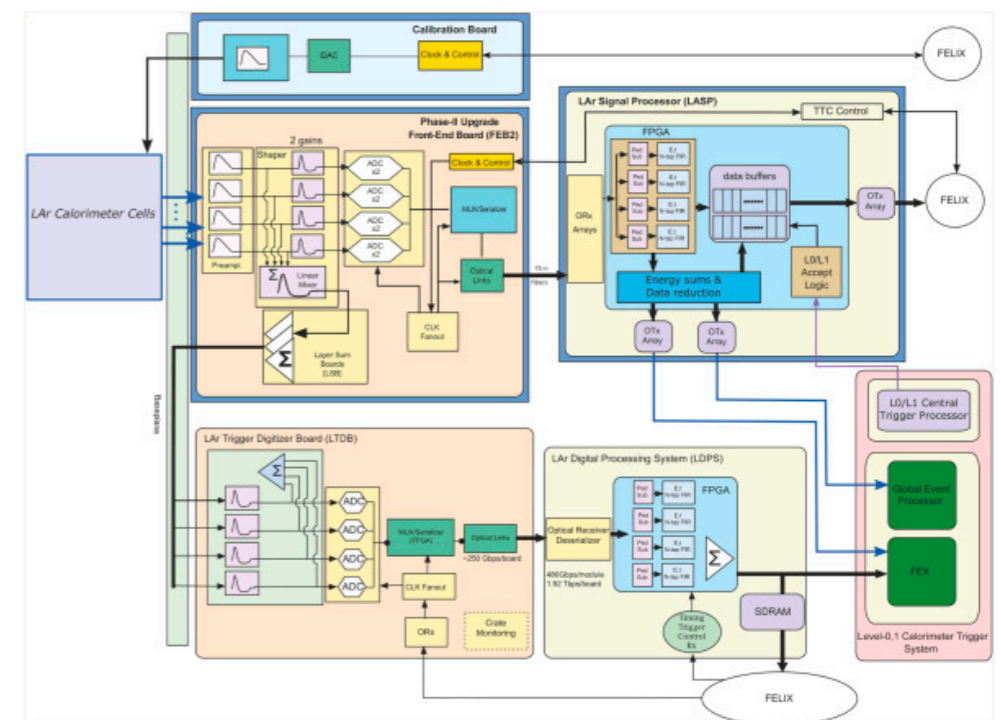
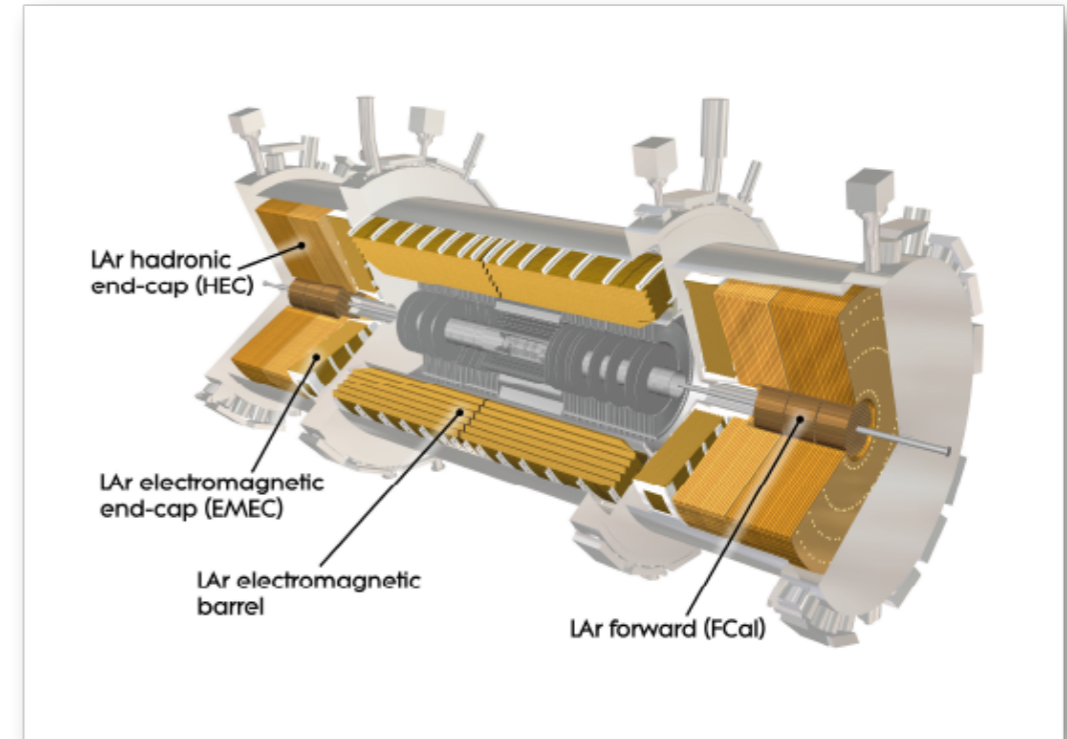

Liquid Argon in Allegro



- 10x the granularity compared to ATLAS
- First stage of readout runs inside the LAr (FPGAs in LAr!)
- Fewer cables ✓
- Less electronics noise ✓
- Difficult access ✗

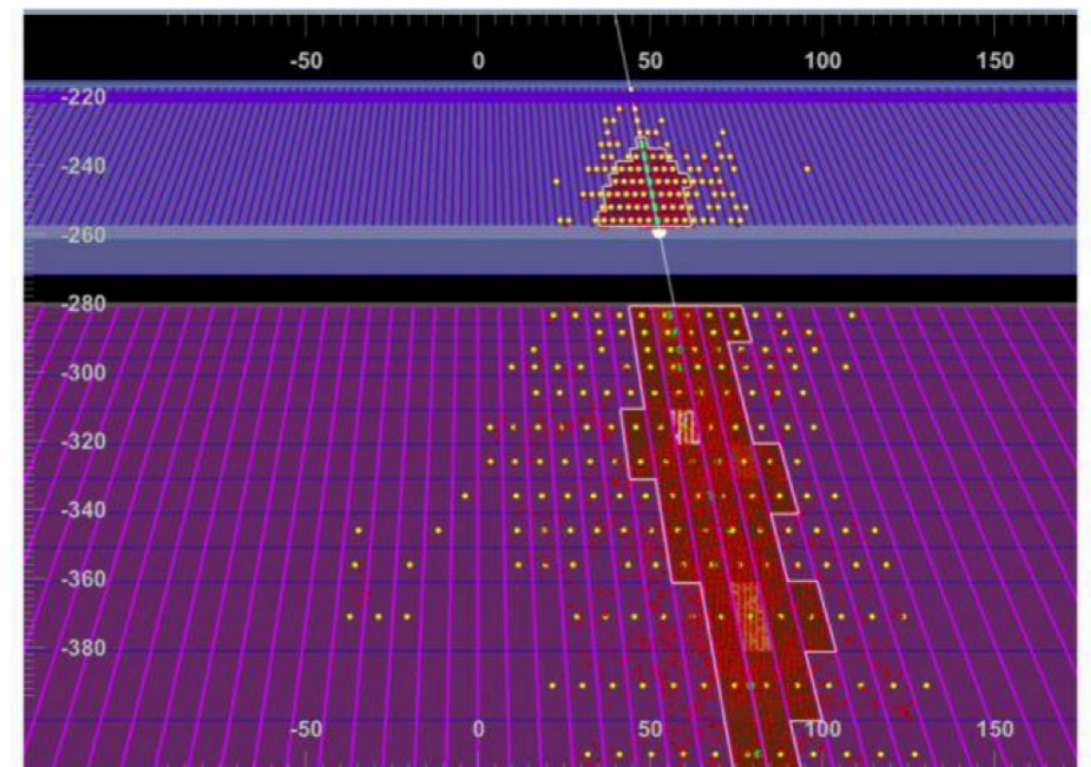
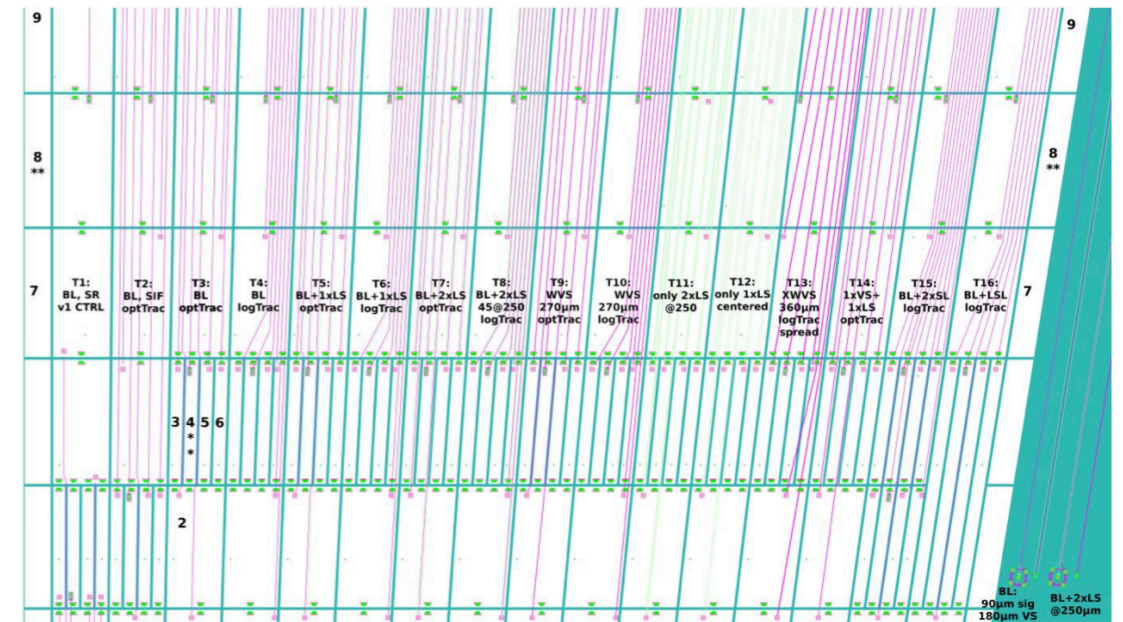

Opportunities in Readout



- LAr pulse shapes are measured to extract energy
 - Pulse shape affected by detector geometry: “cross-talk” from capacitance to nearby cells
- Existing approaches from ATLAS possible...
LArCaloPublicResultsUpgrade
- But could also deploy ML (on FPGAs) to measure energies
 - Existing similar work from ATLAS is promising!
- Many bold possibilities: use information from neighbouring cells to remove cross-talk, etc.

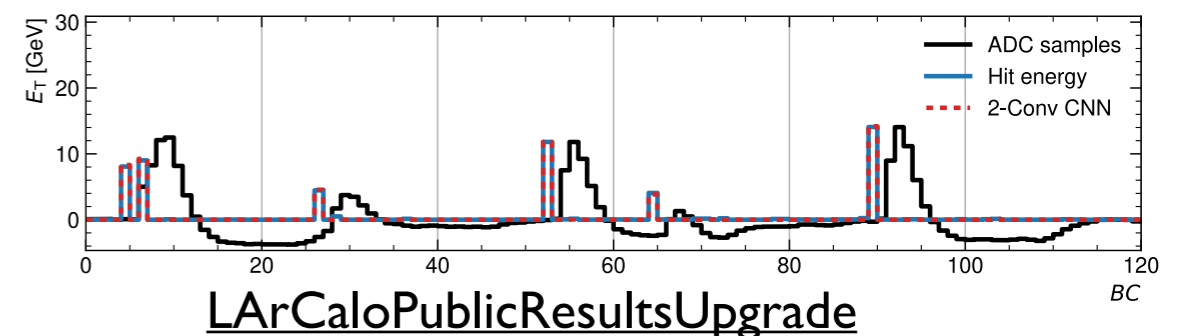
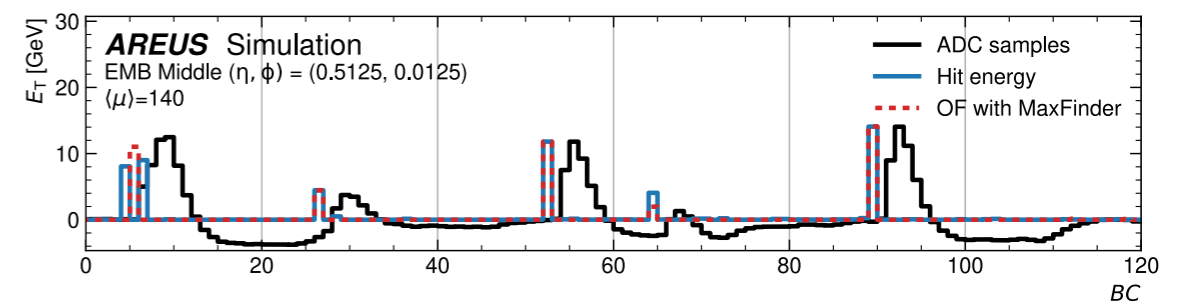
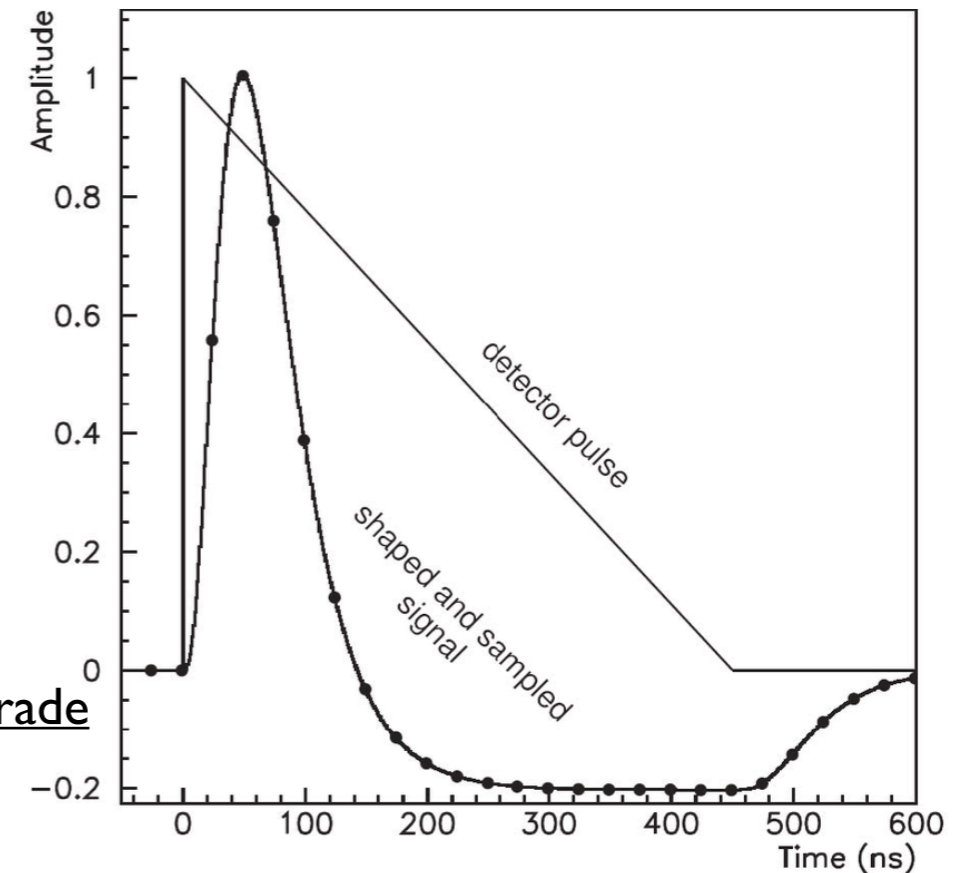

Thoughts



- Lots of experience in building these detectors and electronics in Canada ✓
- Opportunities to grow the community with ML readout ✓
 - From my perspective: this is the most interesting place to deploy ML in DAQ in FCC
 - ML FPGA development is semi-generic: can be applied to other areas later

Conclusions



- Based on the existing detector concepts and Canadian experience, I've proposed a few ideas for our involvement in Calorimetry
- ML readout can also be explored within calorimetry
 - Lessons can be general/applicable elsewhere later if needed?
- Direction will depend on your interest!