

Muon Colliders

2026 CAP Congress
University of Ottawa and Carleton University
Ottawa, ON

24 Jun 2026

David Curtin
University of Toronto



Muons. Why smash?

They are unstable. Why would you do this to yourself?

$$P_{sync}^{loss} \sim \left(\frac{E}{m}\right)^4 \frac{1}{R}$$



This is why protons go in circles and electrons in LINACs.

Circles allow for many kicks → highest energy colliders are synchrotrons

But protons are composite particles, so you gotta deal with all that (messier collisional environment, lower energy / Parton)

Muons are the best of both worlds!? Can put in a synchrotron, reach \gg TeV energies, and then collide elementary particles.

Muon Collider Technology

(with apologies)

Muon Cooling

Can make lots of μ from p on target $\rightarrow \pi \rightarrow \mu$.

If you accelerate them quickly, they can live long enough to form beams and collide!

Big problem: muon cooling! Forming beams requires muons to be tight in phase space. Ionization cooling has made progress (MAP \rightarrow IMCC).

No showstoppers!

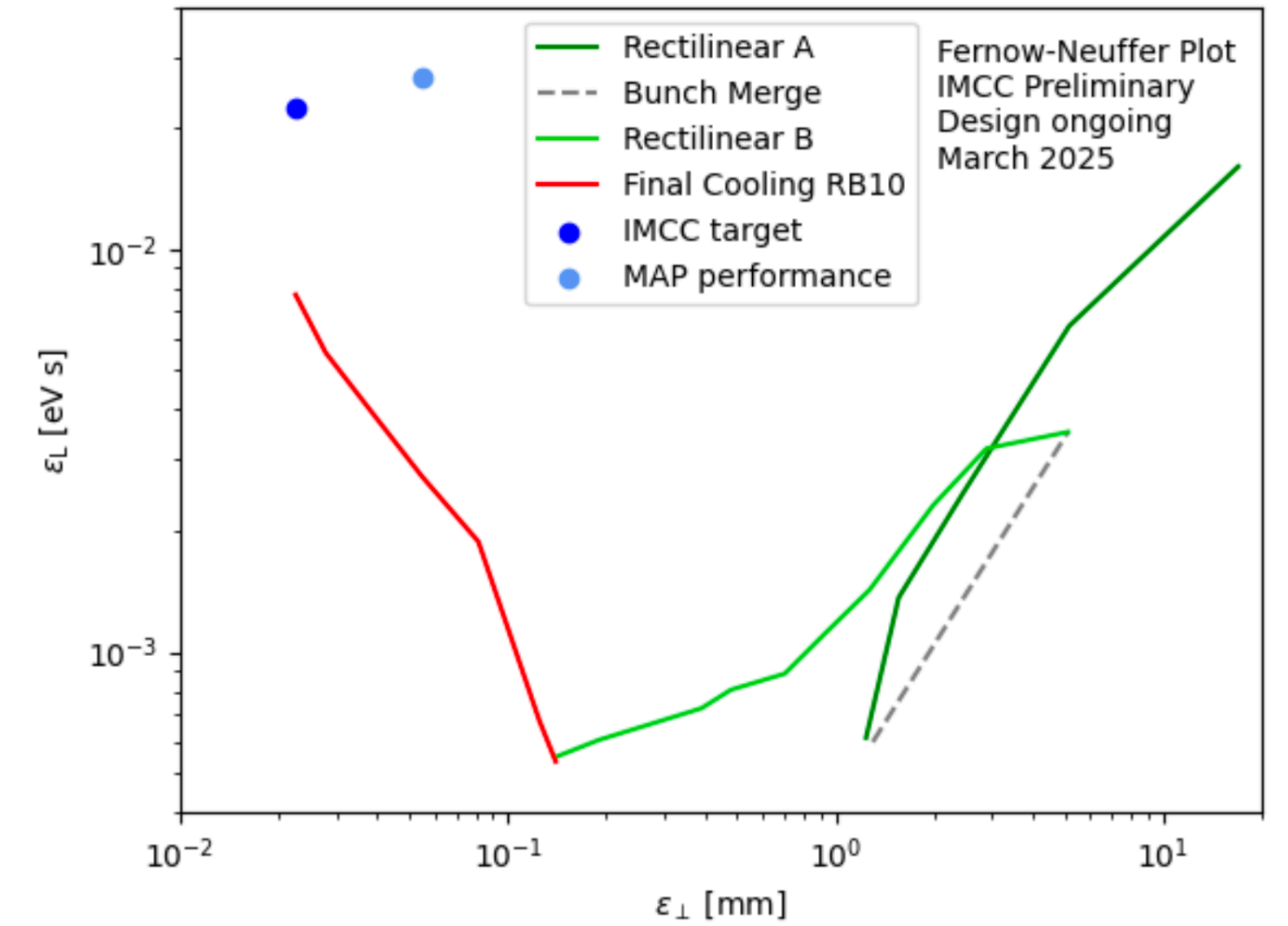
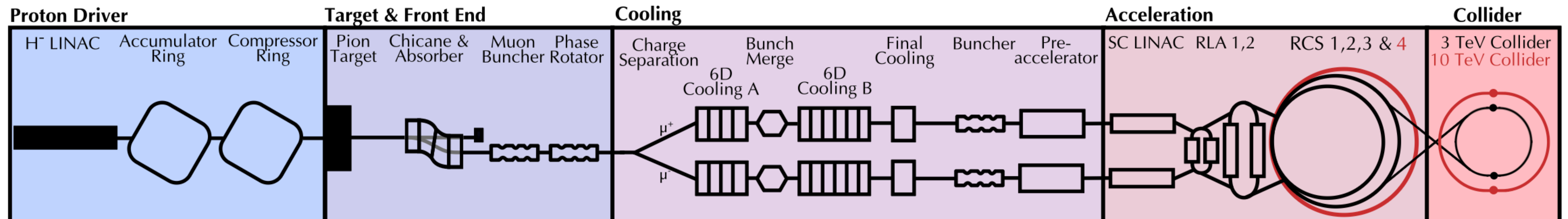

Figure 5.2.2: Current performance estimate for the muon cooling system. Optimisation is ongoing. Best performance so far yields $\epsilon_{\perp}=22.5 \mu\text{m}$, $\epsilon_{\parallel}=7.7 \text{ eV ms}$.



10 TeV Muon Collider

Table 1.1.1: Tentative target parameters for a muon collider at different energies. Scenario 1 corresponds to Energy Staging, and Scenario 2 corresponds to Luminosity Staging. Both are defined in Section 1.8. The estimated luminosity refers to the value that can be reached if all target specifications can be reached, including beam-beam effects.

Parameter	Symbol	Unit	Scenario 1		Scenario 2	
			Stage 1	Stage 2	Stage 1	Stage 2
Centre-of-mass energy	E_{cm}	TeV	3	10	10	10
Target integrated luminosity	$\int \mathcal{L}_{target}$	ab^{-1}	1	10	10	10
Estimated luminosity	$\mathcal{L}_{estimated}$	$10^{34} cm^{-2} s^{-1}$	2.1	21	5 (tbc)	14
Collider circumference	C_{coll}	km	4.5	10	15	15
Collider arc peak field	B_{arc}	T	11	16	11	11
Luminosity lifetime	N_{turn}	turns	1039	1558	1040	1040
Muons/bunch	N	10^{12}	2.2	1.8	1.8	1.8
Repetition rate	f_r	Hz	5	5	5	5
Beam power	P_{coll}	MW	5.3	14.4	14.4	14.4
RMS longitudinal emittance	$\epsilon_{ }$	eVs	0.025	0.025	0.025	0.025
Norm. RMS transverse emittance	ϵ_{\perp}	μm	25	25	25	25
IP bunch length	σ_z	mm	5	1.5	tbc	1.5
IP betafunction	β	mm	5	1.5	tbc	1.5
IP beam size	σ	μm	3	0.9	tbc	0.9
Protons on target/bunch	N_p	10^{14}	5	5	5	5
Proton energy on target	E_p	GeV	5	5	5	5

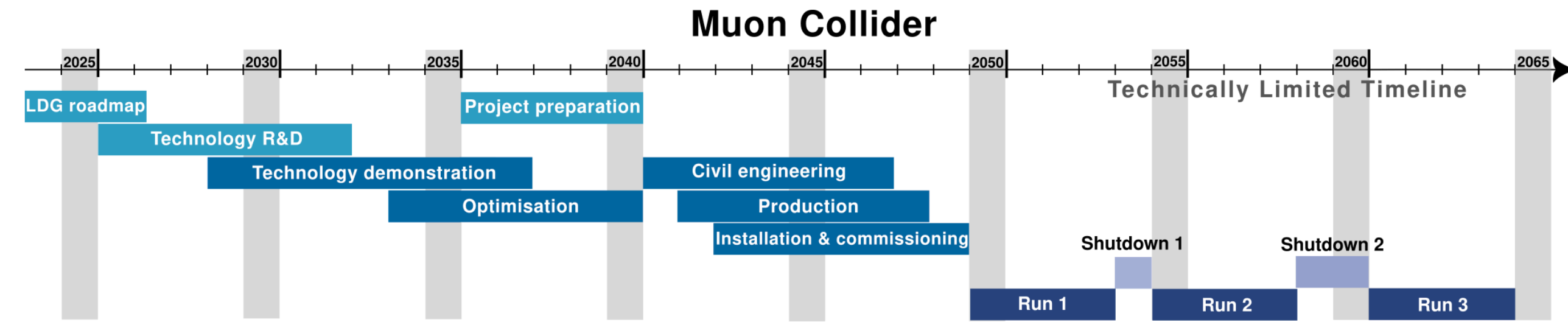

Figure 1.8.1: Technically limited muon collider timeline.

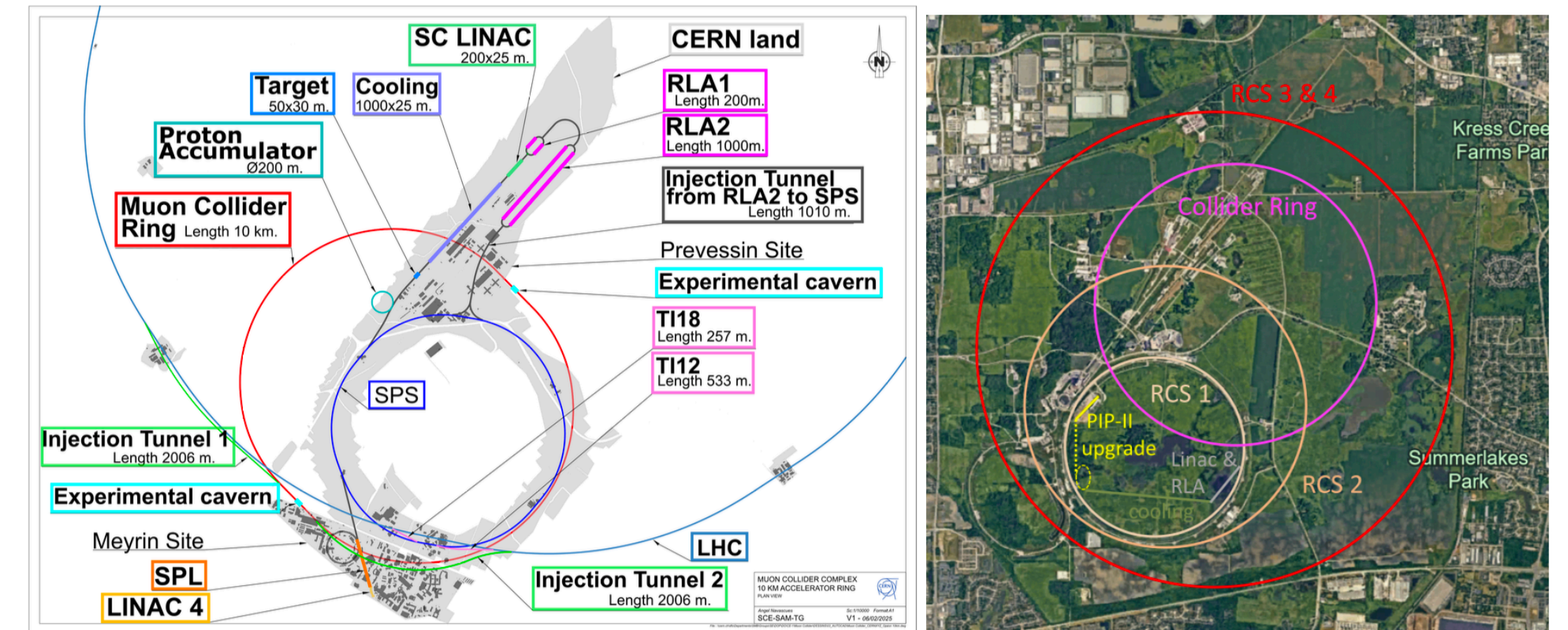

Figure 1.7.1: Conceptual layout of the muon collider at CERN (left) and Fermilab (right).

Source: International Muon Collider Collaboration EUSPP 2504.21417
 (+ most figs in this talk)

Muon Collider might be the fastest way \ll 50y to get to “10 TeV pcm”

Detector

Table 1.3.1: Preliminary summary of the “baseline” and “aspirational” targets for selected key metrics for a 10 TeV muon collider.

Requirement	Baseline	Aspirational
Angular acceptance $\eta = -\log(\tan(\theta/2))$	$ \eta < 2.5$	$ \eta < 4$
Minimum tracking distance [cm]	~ 3	< 3
Forward muons ($\eta > 5$)	tag	$\sigma_p/p \sim 10\%$
Track σ_{p_T}/p_T^2 [GeV^{-1}]	4×10^{-5}	1×10^{-5}
Photon energy resolution	$0.2/\sqrt{E}$	$0.1/\sqrt{E}$
Neutral hadron energy resolution	$0.4/\sqrt{E}$	$0.2/\sqrt{E}$
Timing resolution (tracker) [ps]	$\sim 30 - 60$	$\sim 10 - 30$
Timing resolution (calorimeters) [ps]	100	10
Timing resolution (muon system) [ps]	~ 50 for $ \eta > 2.5$	< 50 for $ \eta > 2.5$
Flavour tagging	b vs c	b vs c , s -tagging
Boosted hadronic resonance identification	h vs W/Z	W vs Z

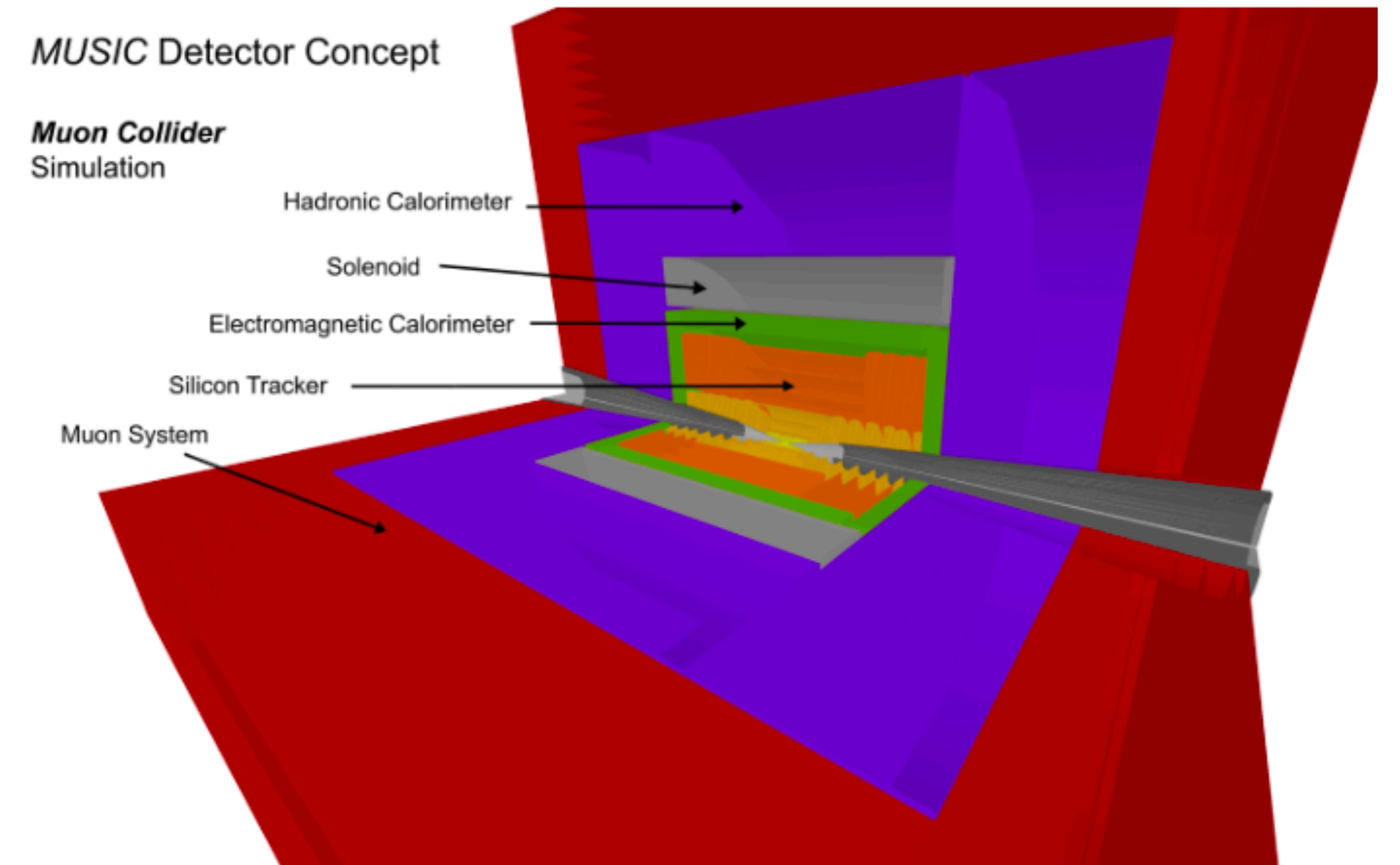

Muon beam decays in-flight, so beam-induced backgrounds (BIB) are a novel challenge for detector design.

Why a Muon Collider?

Energy and Precision

If you want to do high energy particle physics, you need high energy colliders. There is no real substitute for direct searches of new particles.

MC is effectively two very precise colliders in one: high-E DY production machine + low-E high lumi VBF collider from muon PDF, covers new physics across whole E range.

T.Han, Y.Ma, K. Xie
2007.14300

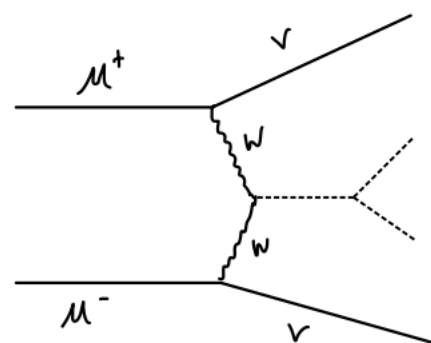
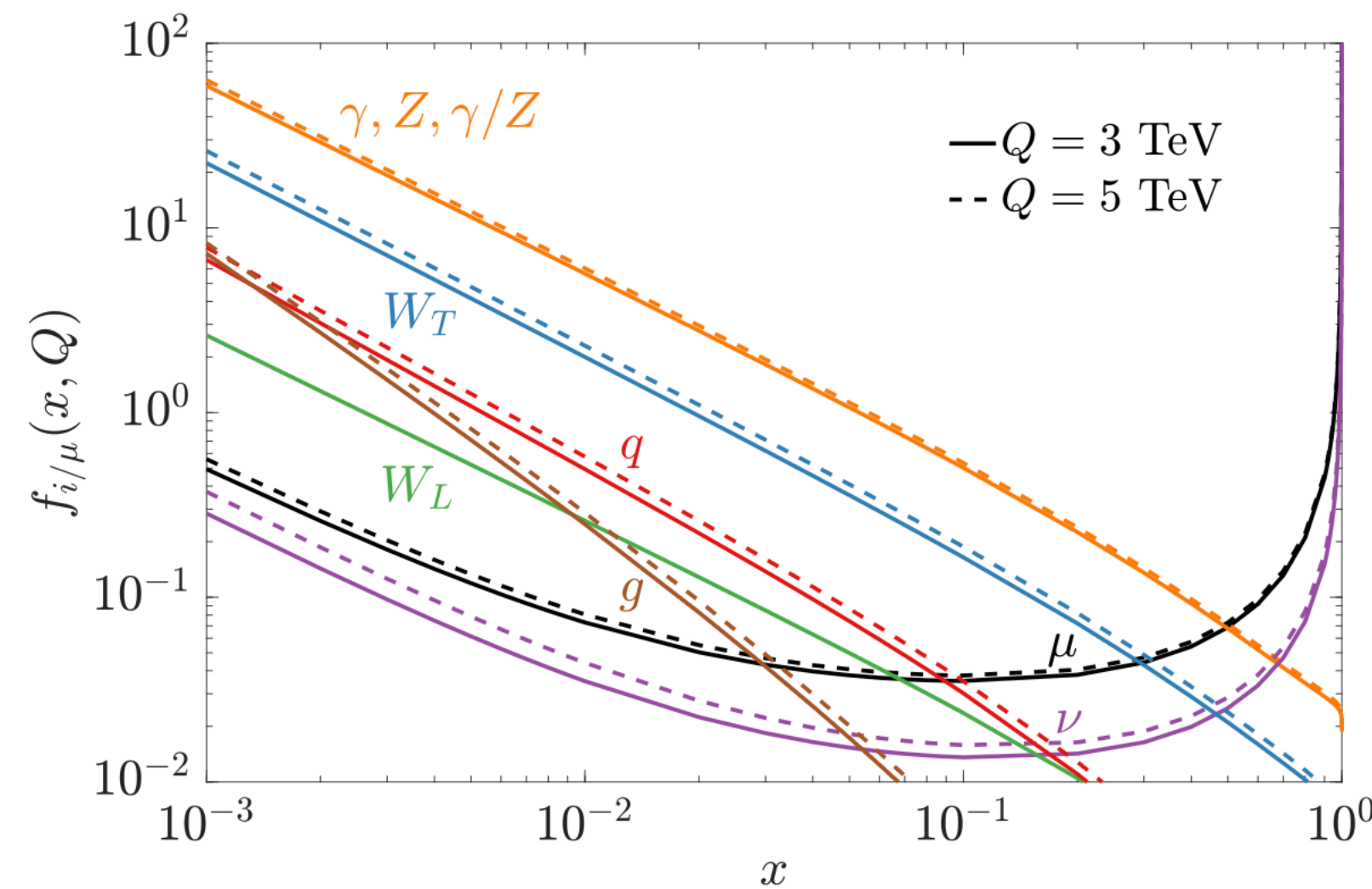

muons and neutrinos peak at $x \sim 1$
EW + more sea

Ability to directly look for any particles within range of machine

“Low” energy program is enhanced from dynamical energy range $\sim \log^2 E^2$

High energy DY w/ $\mathcal{O}(10^4)$ events at 10 TeV

Slide from P. Meade

A Muon Facility with a Broad Physics Program

Summary of the handle and frame physics of a muon collider facility...

- Proton driver: CLFV and Kaon experiments
- Muon capture off target: Muon storage ring first gen neutrino factory
- After Muon Cooling/Acceleration: Neutrino factory, oscillation and cross section measurements (new detectors and reusing DUNE)
- Exquisite mass and or width determinations for EW particles
- Potential beam dump experiments and more ideas - it's about *options*
- This is *actively* being explored as it's particularly compelling for US facilities, priorities, and uniting our communities

Slide from
P. Meade

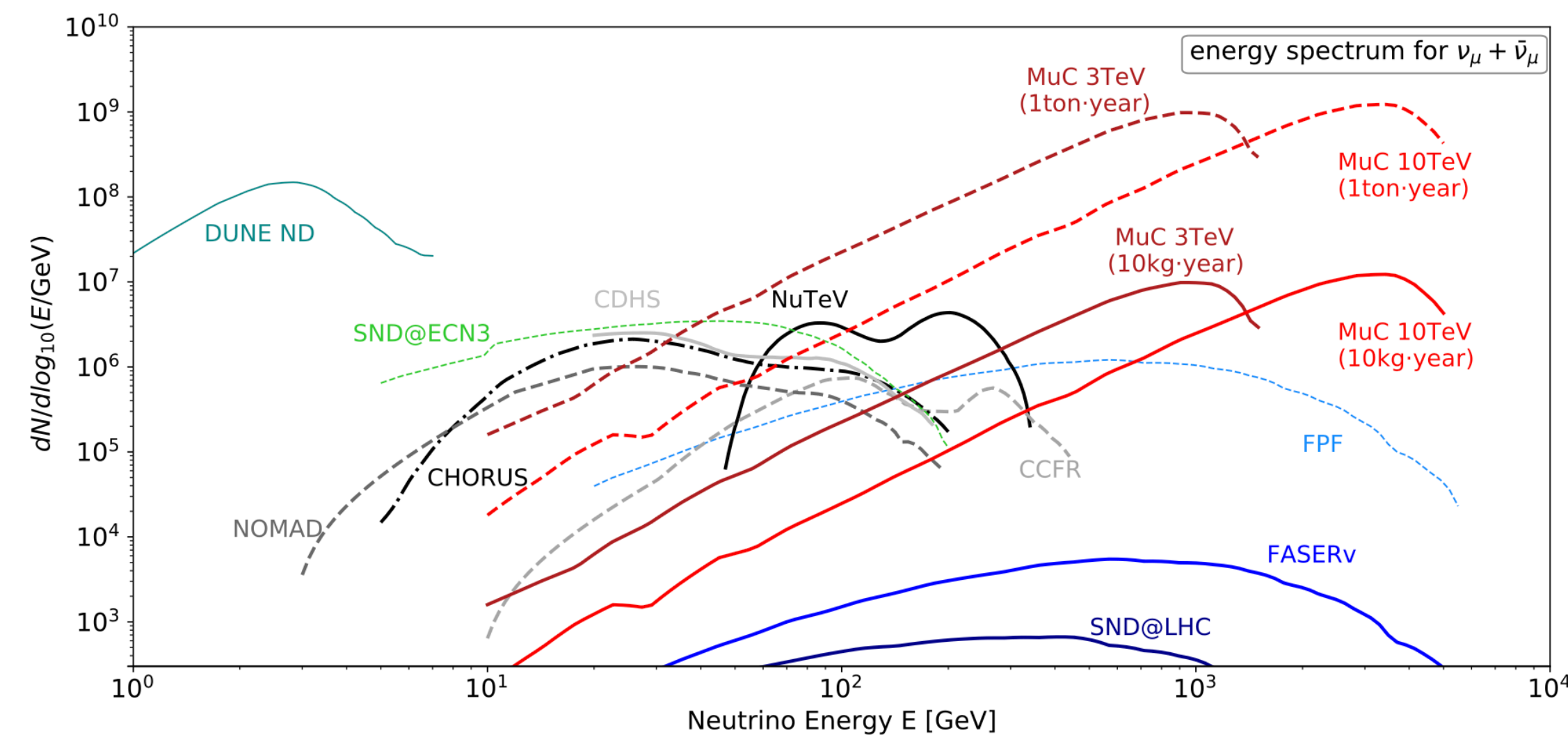
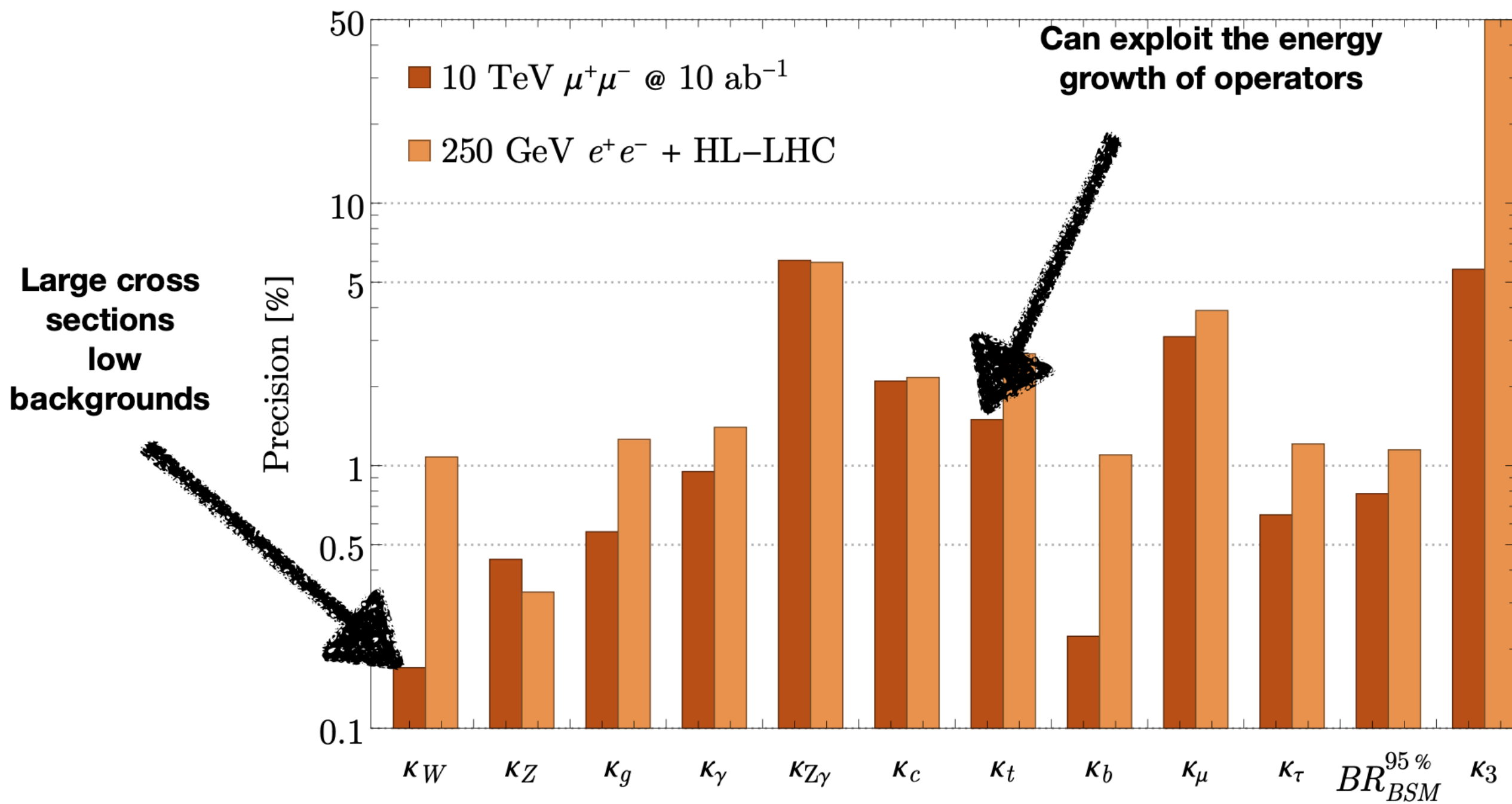

Figure 2.4.1: The energy spectrum of neutrino interactions produced by the 3 TeV and 10 TeV MuC in one year, overlaid with the summary plot in Ref. [256] for past and planned neutrino experiments. The solid and dashed lines assume, respectively, a small 10 kg and a realistic 1 ton target mass.

Physics at Muon Colliders

Higgs Precision

A 10 TeV muon collider acts like a low-energy higgs factory alongside a high-energy discovery machine.



	HL-LHC	HL-LHC +10 TeV	HL-LHC +10 TeV + ee
κ_W	1.7	0.1	0.1
κ_Z	1.5	0.2	0.1
κ_g	2.3	0.5	0.5
κ_γ	1.9	0.7	0.7
$\kappa_{Z\gamma}$	10	5.2	3.9
κ_c	-	1.9	0.9
κ_b	3.6	0.4	0.4
κ_μ	4.6	2.4	2.2
κ_τ	1.9	0.5	0.3
κ_t^*	3.3	3.0	3.0

* No input used for the MuC

Higgs Potential

Can determine the shape of the Higgs potential experimentally (measure h^3, h^4, y_t, \dots).

Crucial first principles characterization of Higgs sector. Allows us to nail down SM vacuum stability, whether EW phase transition was first-order or not (baryogenesis etc),

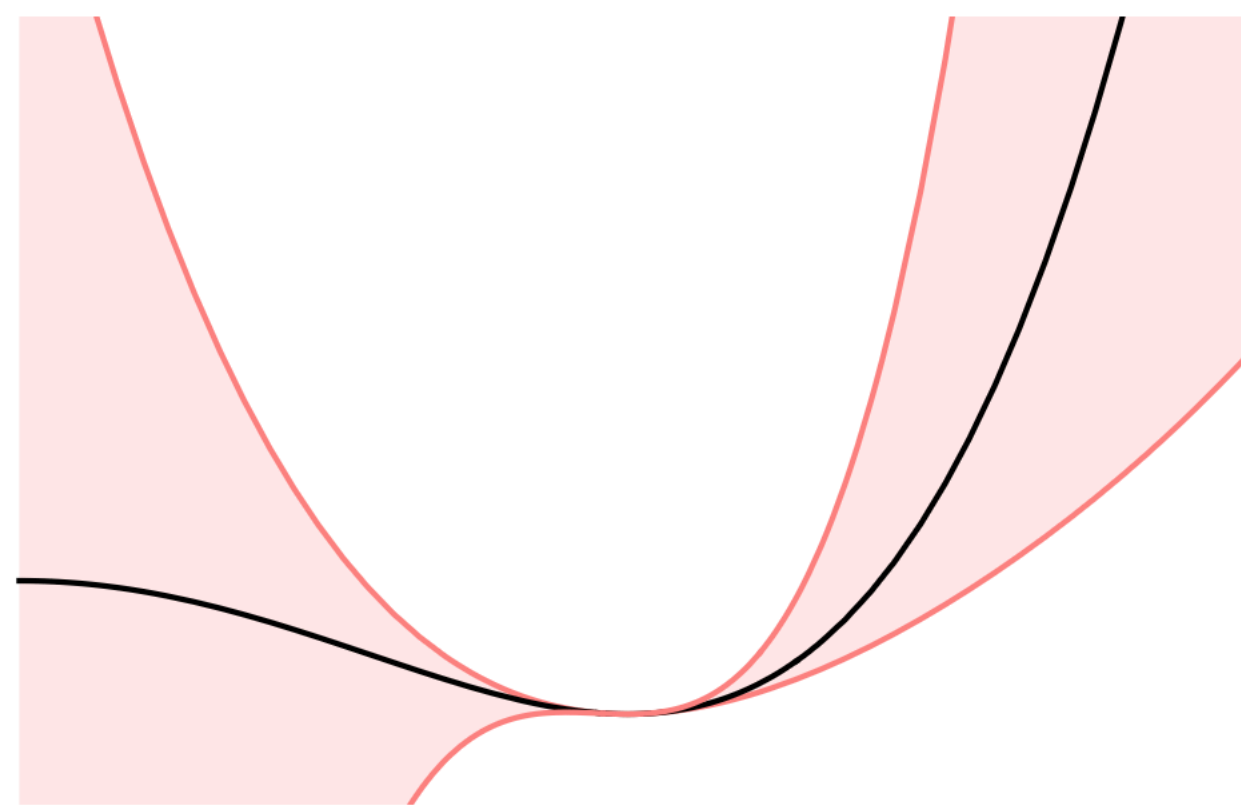
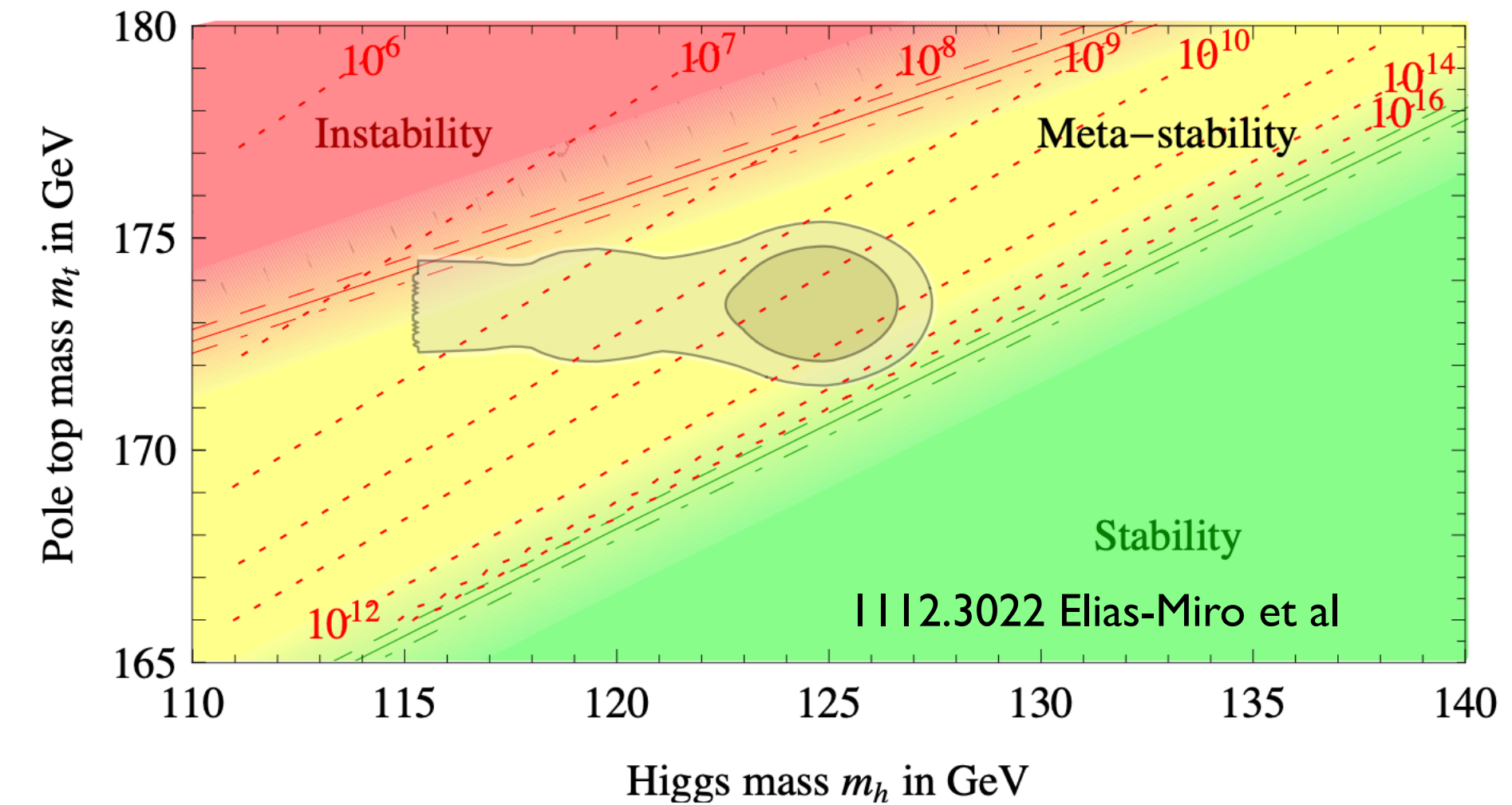

Current LHC

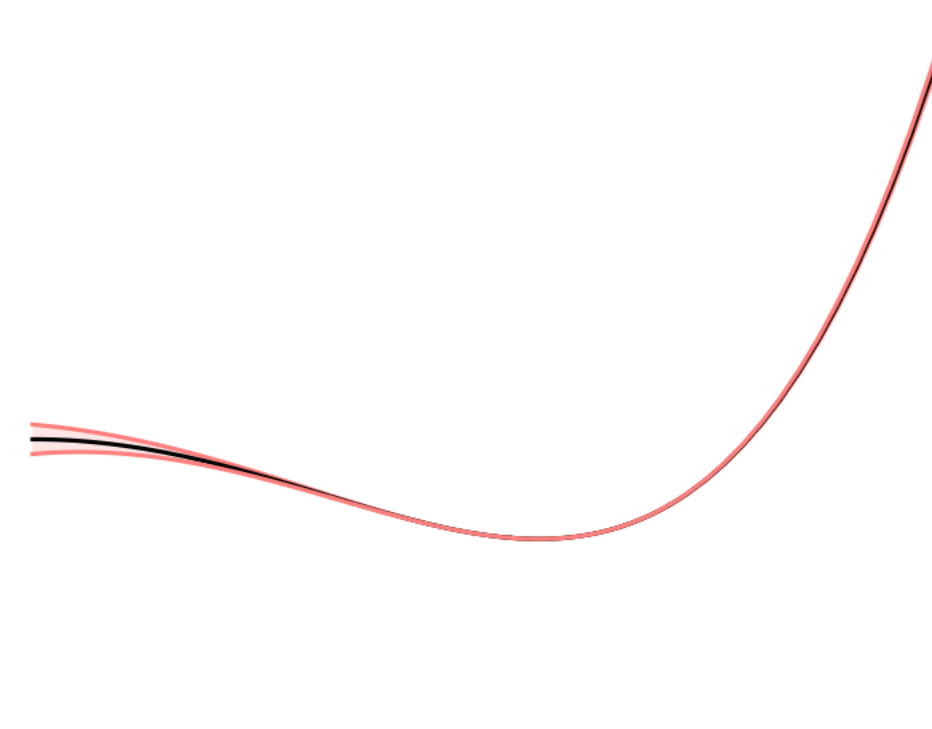

10 TeV μ Col

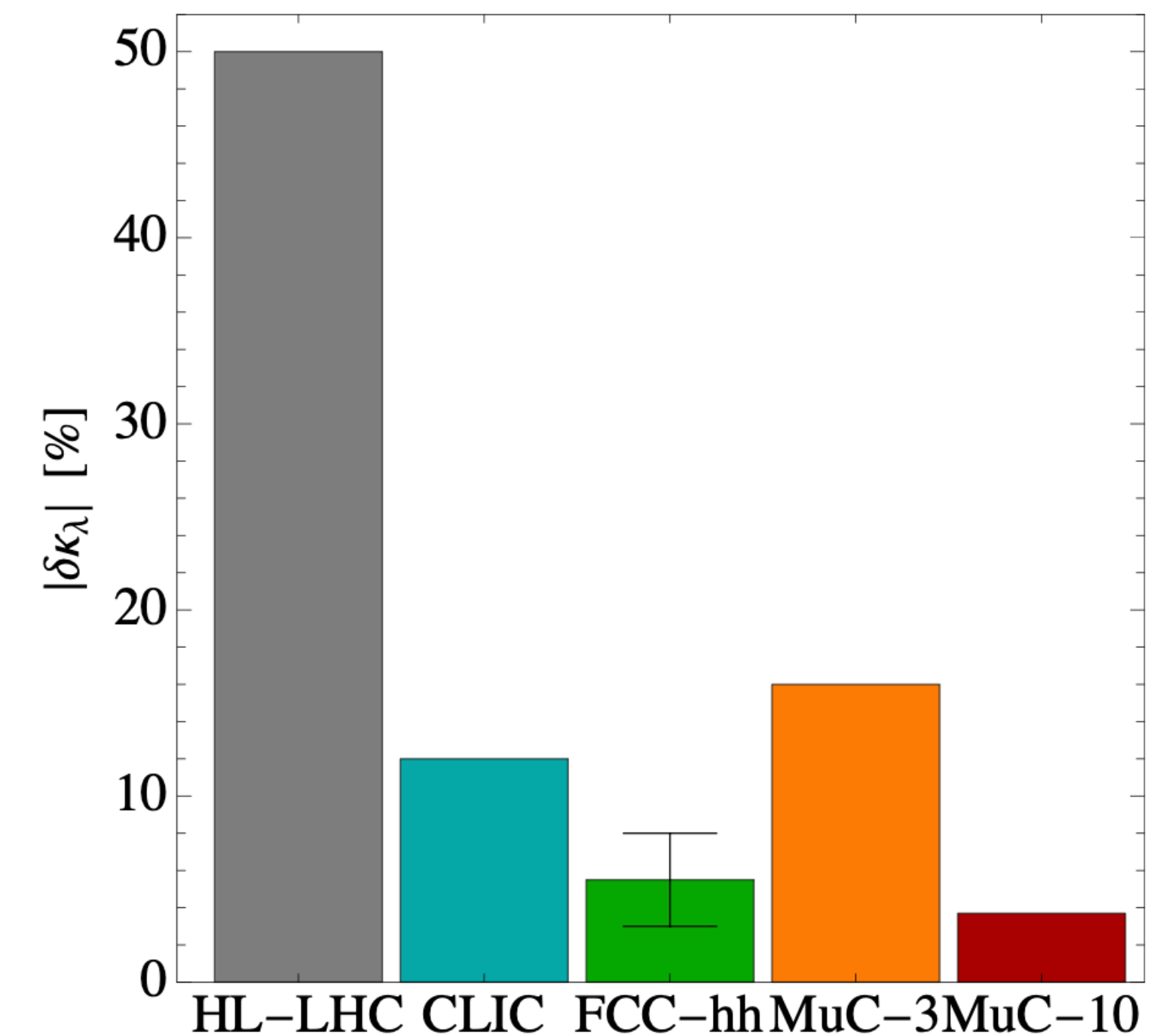

The Hierarchy Problem Still has Teeth!

Any heavy physics at scale M with coupling g to the Higgs will generate a finite loop correction to its mass:

$$\Delta m_H^2 \sim \frac{g^2}{4\pi} M^2 \quad \Rightarrow \quad \text{If } M \gg m_H^{exp} = 125 \text{ GeV, you have a severe tuning.}$$

It is highly plausible that such heavy physics exists:

- we know for a fact that there is BSM physics (Dark Matter, Baryogenesis)
- There is plenty of evidence which suggests some new physics at high mass scales (grand unification? inflation! leptogenesis? quantum gravity!...)
- $|H|^2$ is an *everything*-singlet \rightarrow it will couple to everything.

\Rightarrow Some solution for the Hierarchy Problem is as needed as ever.

Higgs Compositeness

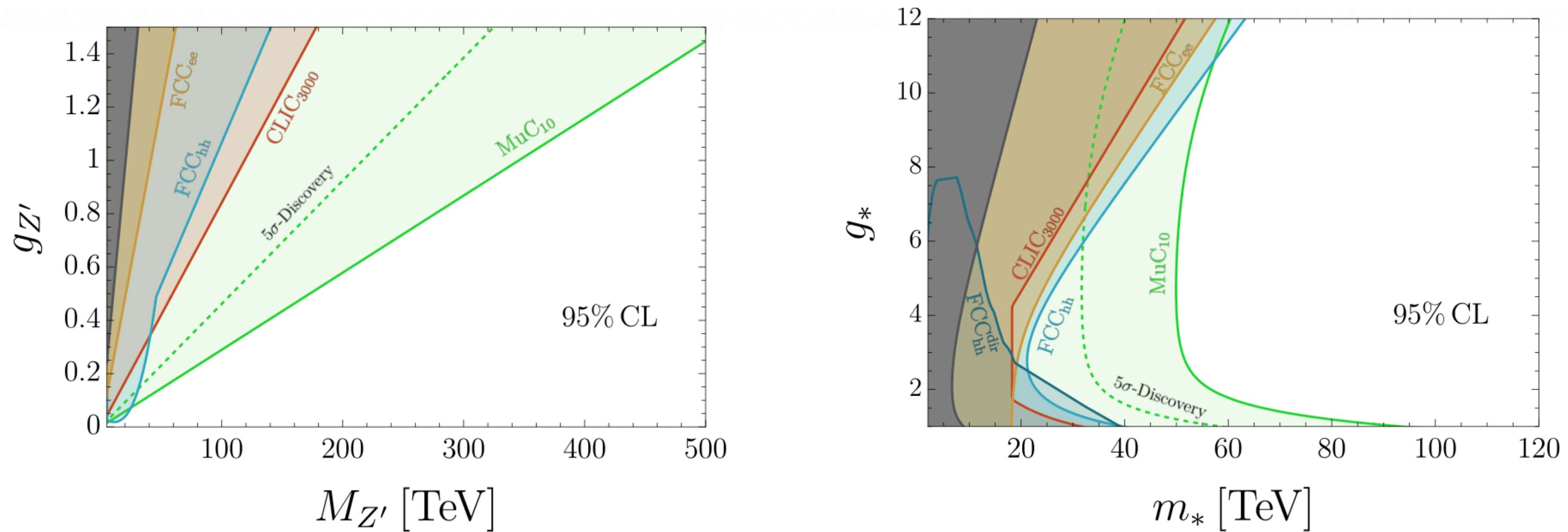
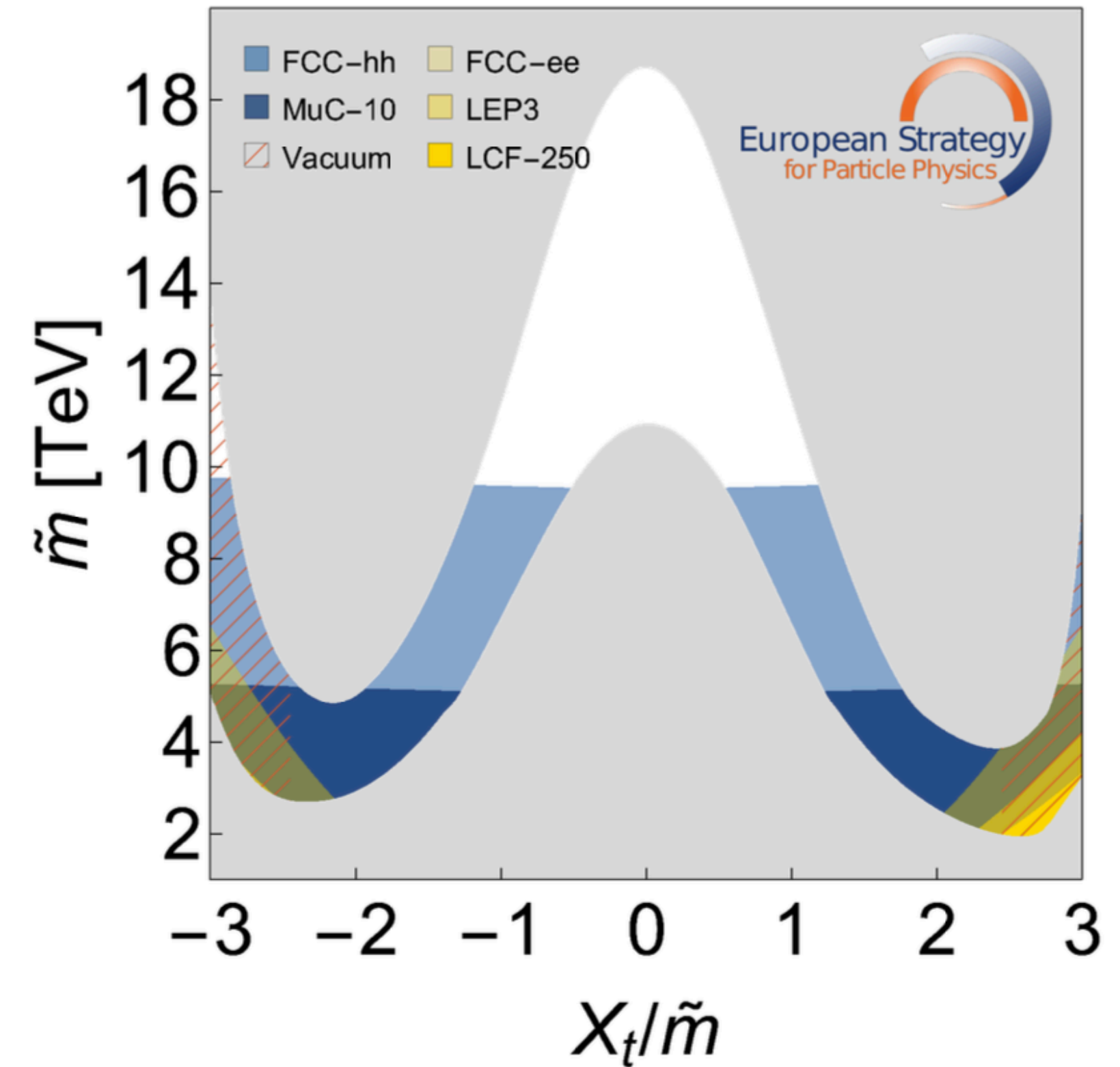
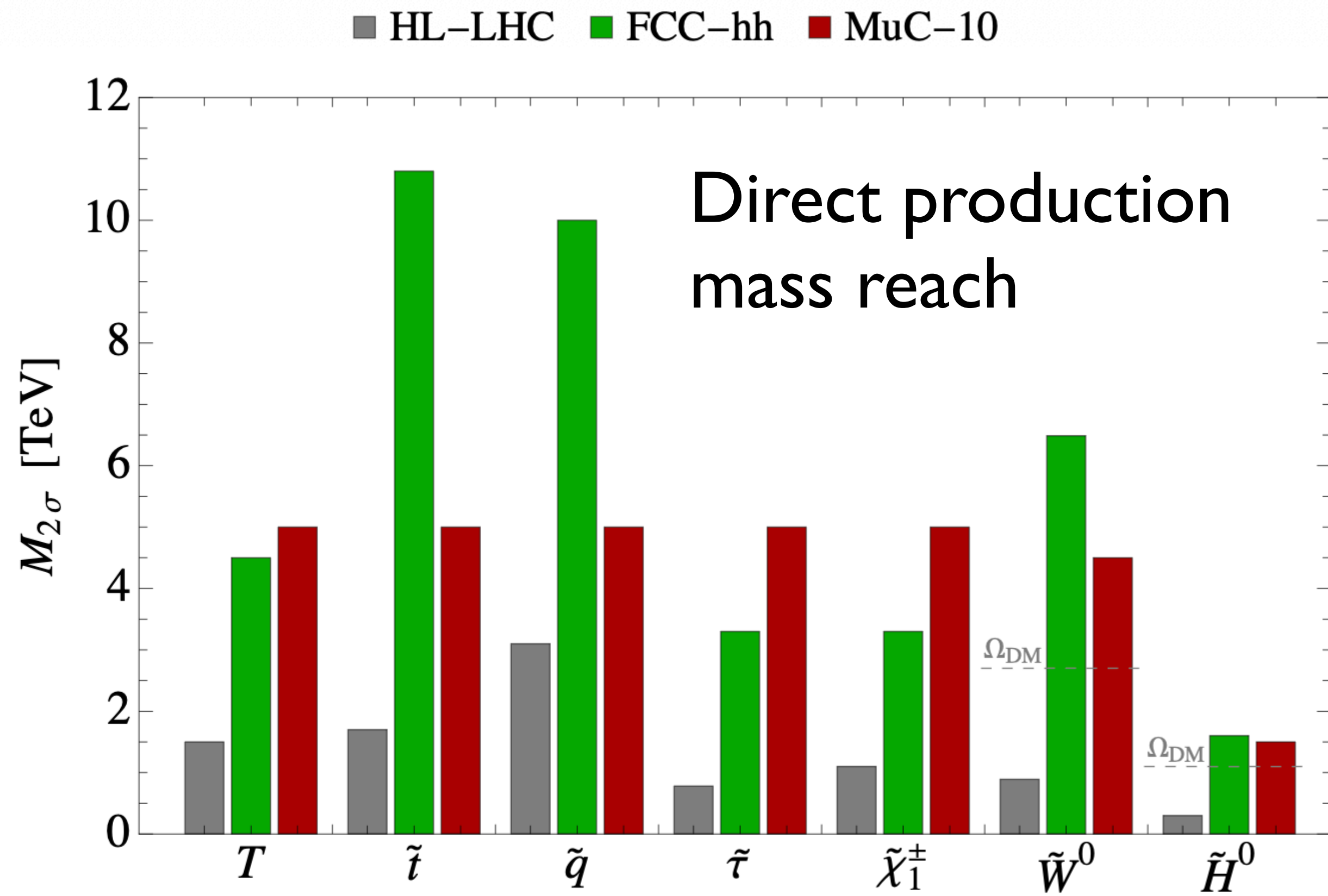

Figure 2.2.4: Left: Future colliders 95% CL exclusion sensitivity to a minimal Z' [210]. In the case of muon colliders, the 5 σ discovery reach is also shown by dashed lines. Right: The sensitivity to Higgs compositeness.

MuC is uniquely excellent at probing higgs compositeness, since it measures both high-precision higgs coupling modifications AND high-energy modifications of DY processes

Supersymmetry

Realistic SUSY models at the 10 TeV scale require TeV-scale EW states for the MC to produce directly.



MuC's for Generalized Naturalness

Going beyond SUSY and composite Higgs, there are several solutions to the *little* hierarchy problem which avoid TeV-scale coloured top partners:

Twin Higgs: Minimal, Fraternal, Orbifold, ...

Folded SUSY

Quirky Little Higgs

Hyperbolic Higgs ...

Burdman, Chacko, Goh, Harnik hep-ph/0609152

Craig, Katz, Strassler, Sundrum 1501.05310

Craig, Knapen, Longhi 1410.6808

Barbieri, Hall, Harigaya 1706.05548

Barbieri, Greco, Rattazzi, Wulzer 1501.07803

Cai, Cheng, Terning 0812.0843

Cohen, Craig, Giudice, McCullough 1803.03647

...

They all have in common:

- dark sector(s) related to SM by discrete symmetry
- **UV completions around $\lesssim 5$ TeV featuring ***new electroweak states***. Prime discovery target for MC.**

Dark Matter

MC is an outstanding machine to explore anything electroweak above the TeV scale.

It can discover many DM candidates in EW reps, including extremely challenging higgsinos decaying to soft tracks.

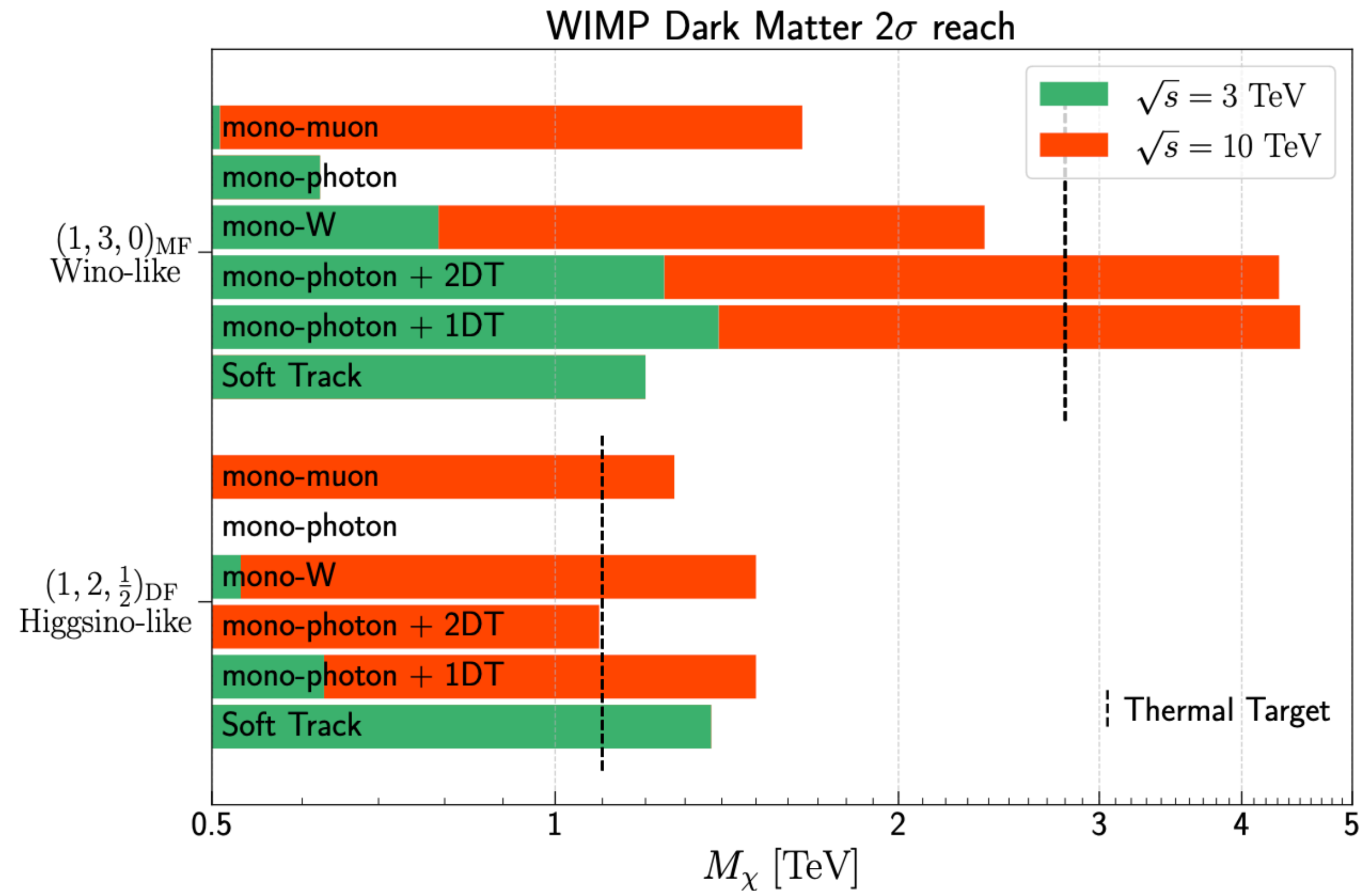
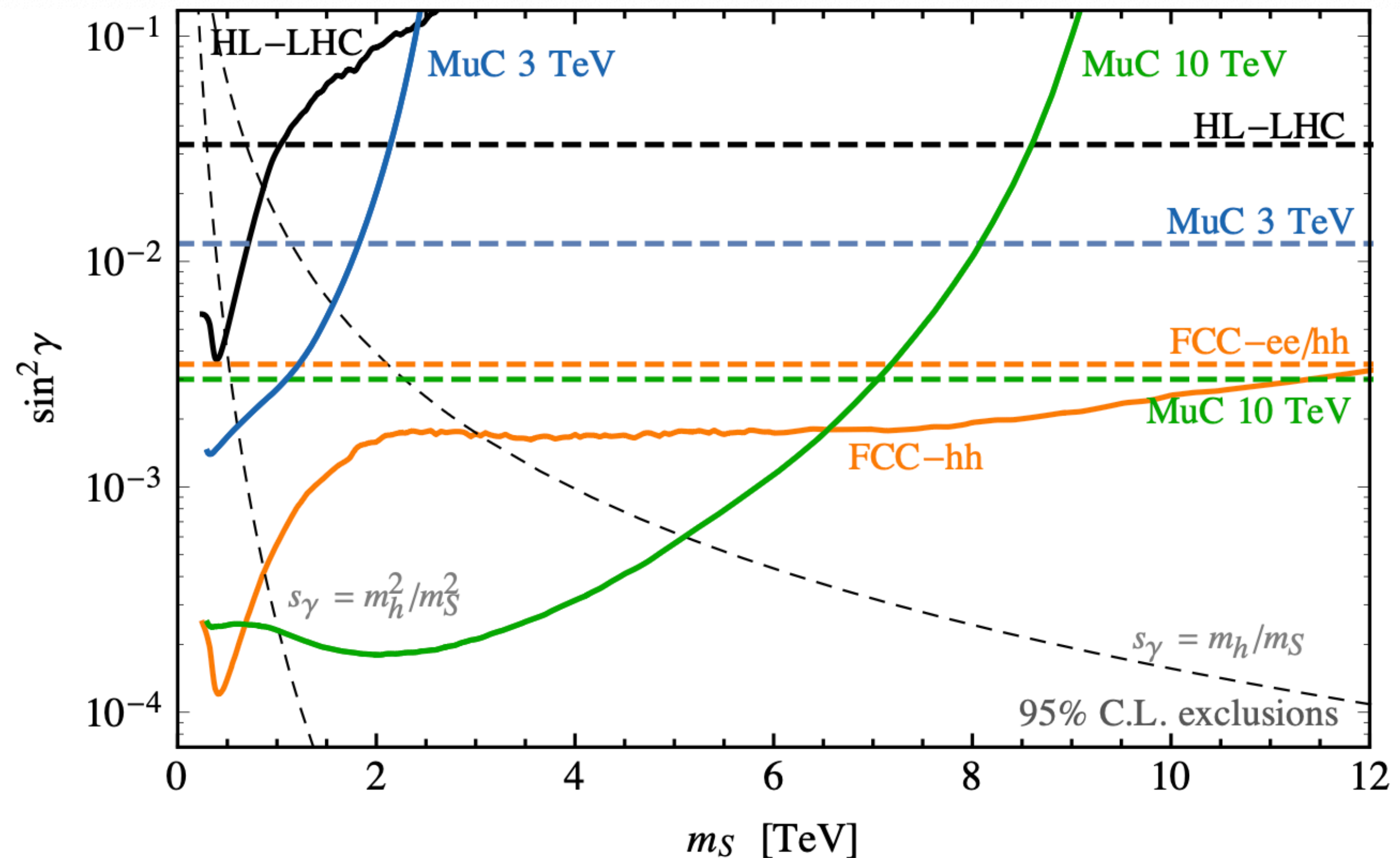

Figure 20.0.1: 2σ exclusion of fermion DM masses from different search channels. Horizontal bars for individual search channels and muon collider energies by the different colors. The vertical bars indicate the thermal mass targets. The reach in the mono-photon channel is taken from Ref. [80], and the results of mono-W is taken from Ref. [13]. The reaches for the disappearing track are extrapolated from Ref. [82], and the sensitivity using soft tracks are studied for 3 TeV muon collider in Ref. [93].

Dark Sectors

The higgs portal $|H|^2 \mathcal{O}_{BSM}$ is one of the best ways of accessing an arbitrary dark sector, low-dimension operator always allowed by symmetries. The higgs factory aspect (exotic Higgs decays) and high energy gives MC excellent reach

e.g. singlet mixed with higgs,
Proxy for many dark sectors
That couple via higgs portal



SMEFT and Flavour

Combination of clean final state and high energy makes for excellent probe of high-scale dim-6 operators

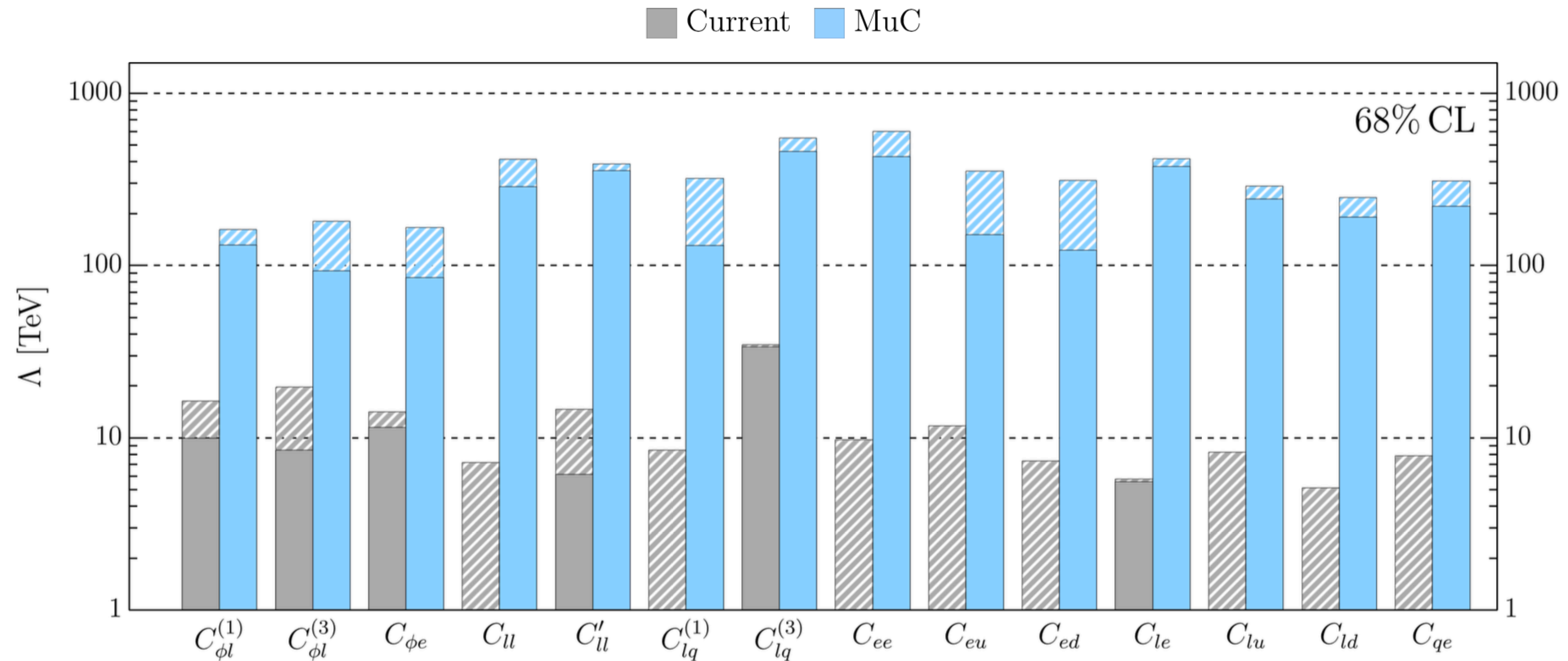

Figure 2.2.5: Fit to the CP -even flavour-blind Warsaw basis [213] operators that grow with the energy and interfere with the SM in di-fermion and di-boson production at the MuC. The MuC projections (blue bars) from the measurements of these observables are compared with current knowledge (gray bars).

SMEFT and Flavour

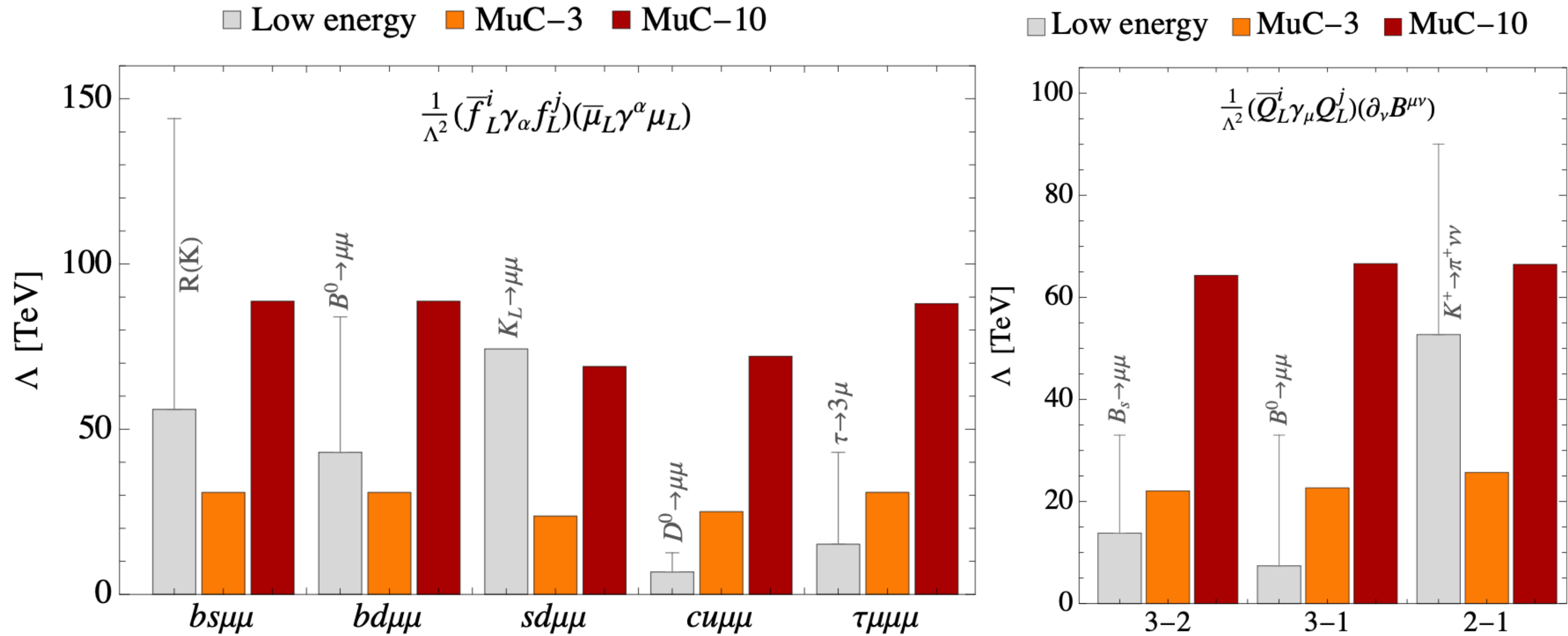

Figure 2.3.1: Sensitivity reach in the effective scale Λ [TeV] of effective operators containing a quark or lepton flavour-violating current, coupled to either a muon current (left panel) or a flavour-blind gauge current. The gray bands show the present constraints from meson [223–226] and tau [227] decays, while the gray lines are the expected future sensitivity at the end of LHCb upgrade II [228], Belle II [229], and NA62 [230] runs.

Conclusions

Conclusions

A muon collider could give you the best of all worlds: high energy, high precision, a higgs factory and a high-energy discovery machine all in one.

Much R&D left to be done, but no apparent showstoppers.

Could reach 10 TeV “partonic center-of-mass” in \ll 50 years

Uniquely excellent probe of 1-10 TeV electroweak physics:
higgs potential, generalized naturalness, DM, ...

Muon Collider would form one part of a broad Muon Facility physics program.

Could bring the cutting edge of high energy physics to North America. A physicist can dream...