

Radon Mitigation Techniques for PICO-500 Assembly

CAP 2026

Agenda

- **PICO Detectors**
 - What is a bubble chamber?
- **PICO-500**
 - Usual backgrounds
 - What is radon?
 - Mitigation techniques
 - Estimates & timelines



Credit: Lily Hines, MI/PICO

Bubble Chambers as Particle Detectors

- Pressure: **~200 psia or 13 atm**
- Temperature: **12C**

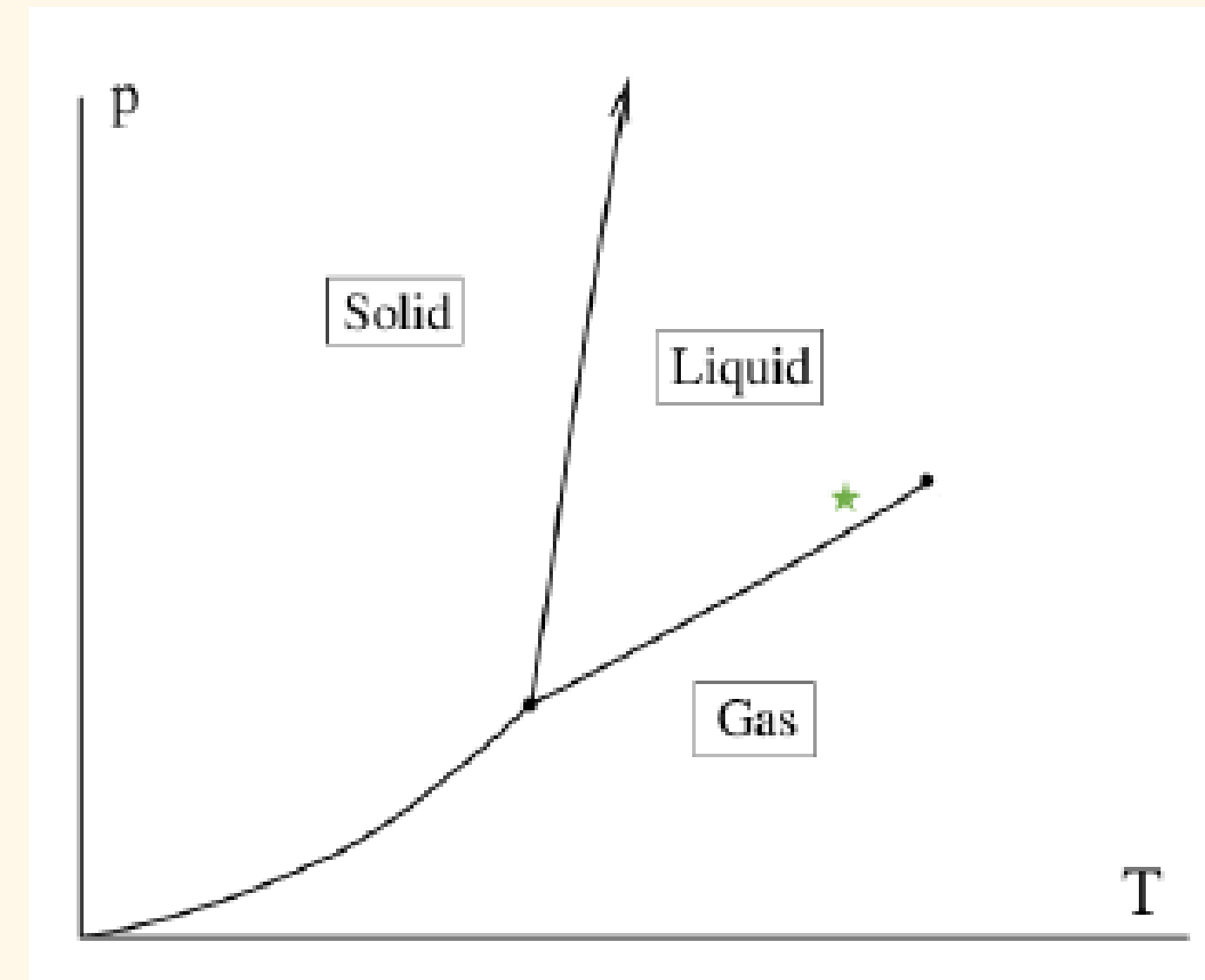
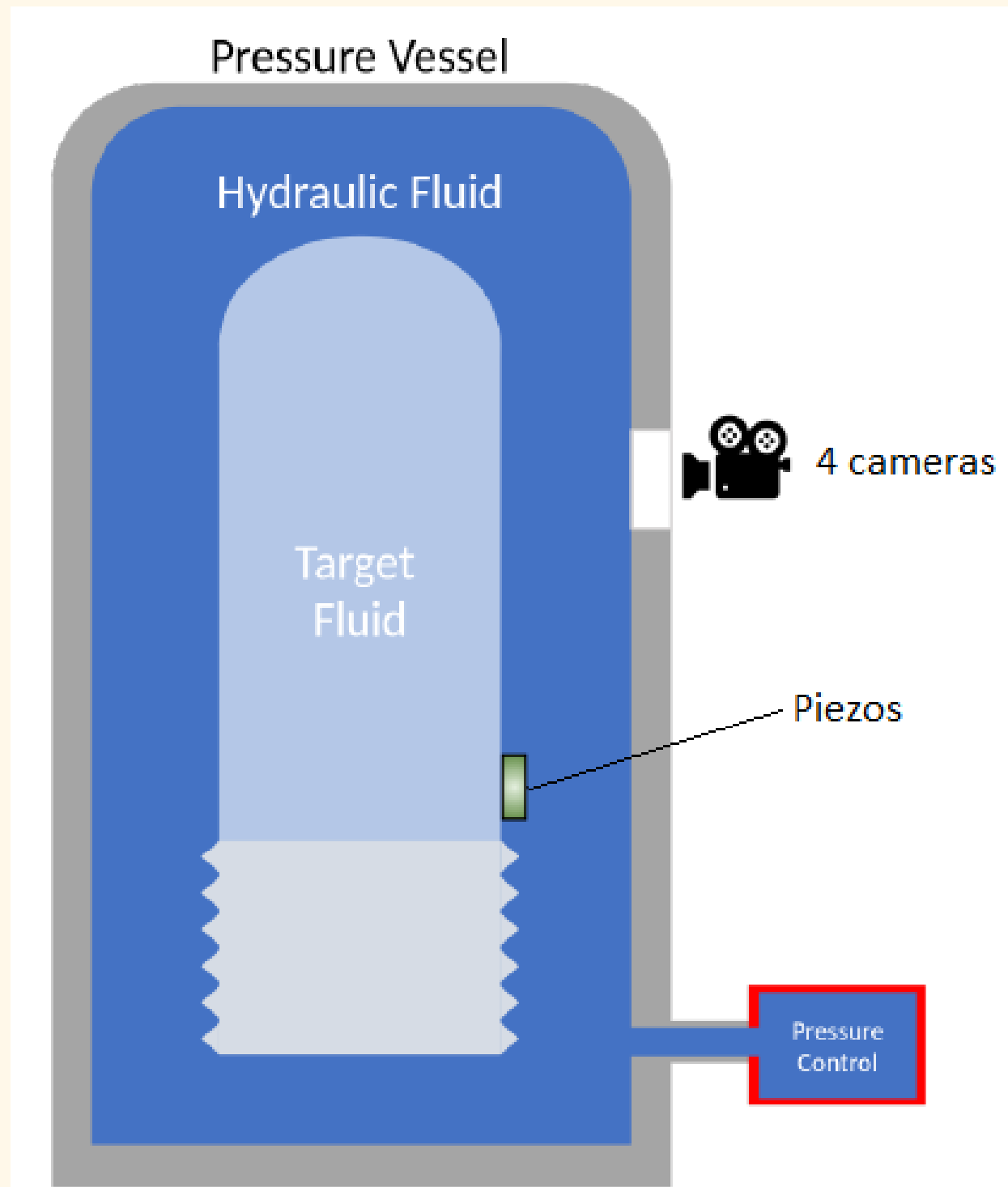

Compressed

Bubble Chambers as Particle Detectors

- Pressure: **30 psia or 2 atm**
- Temperature: **12C**

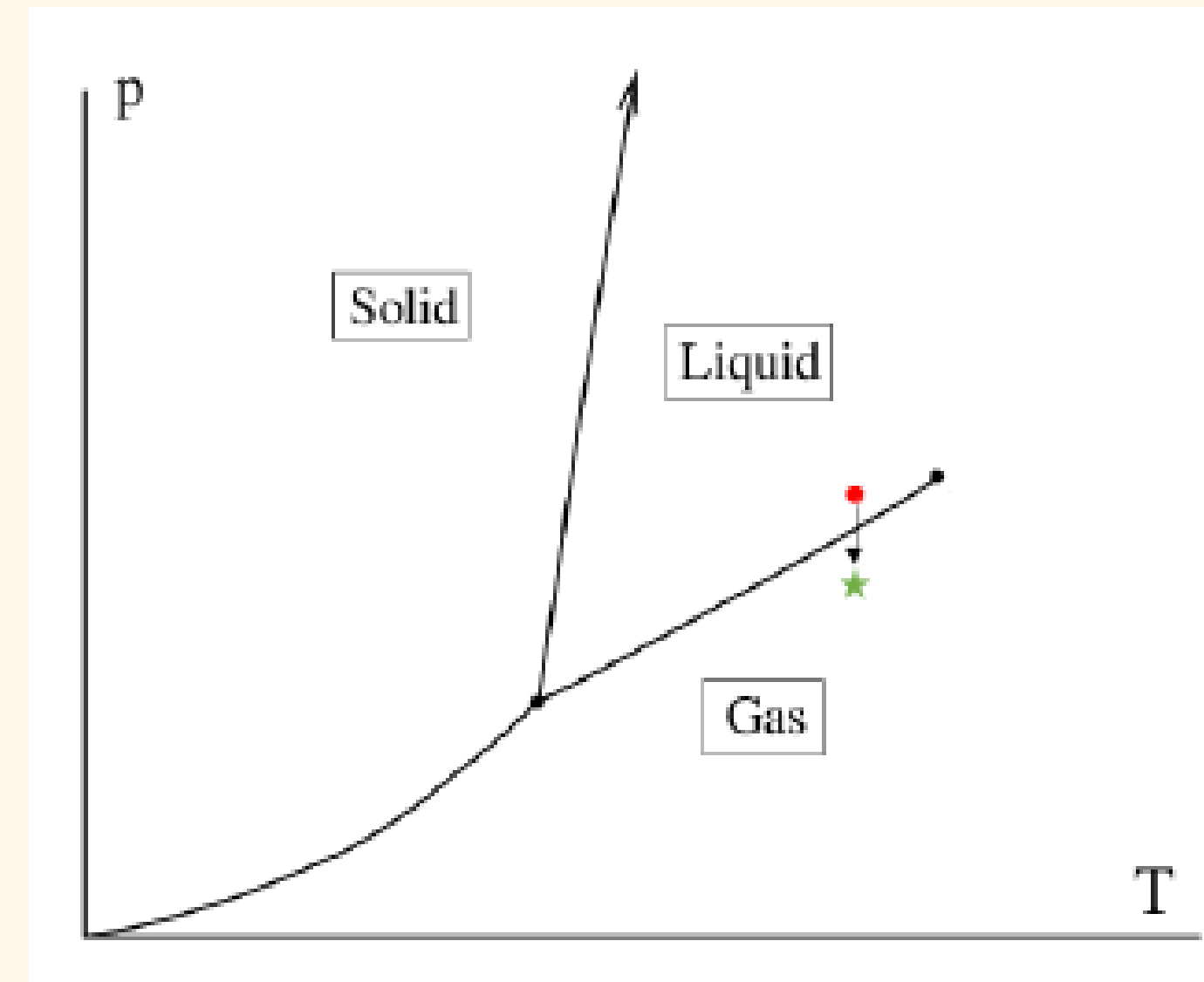
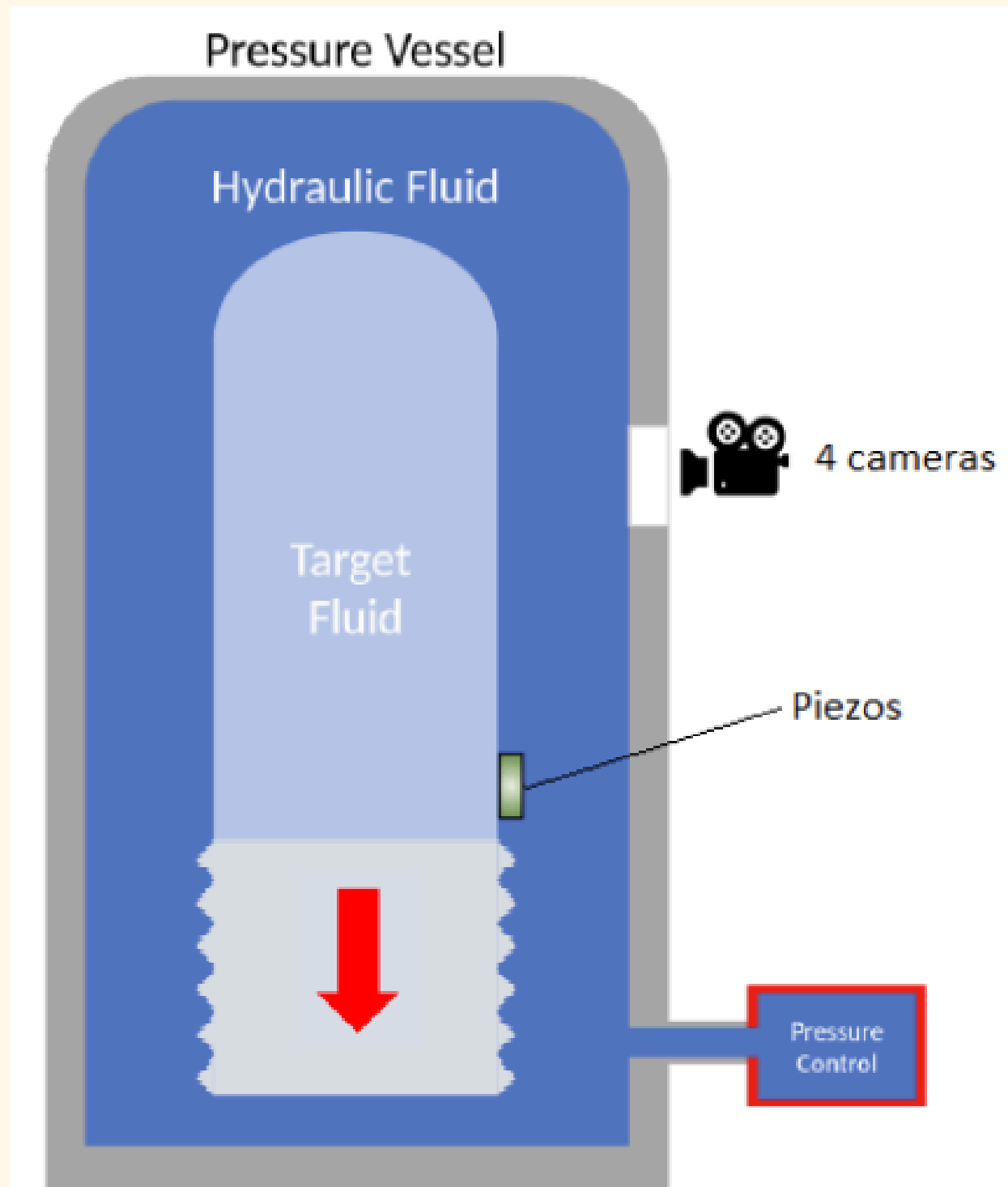

Expanded

Bubble Chambers as Particle Detectors

Fluid in a **pure liquid state**

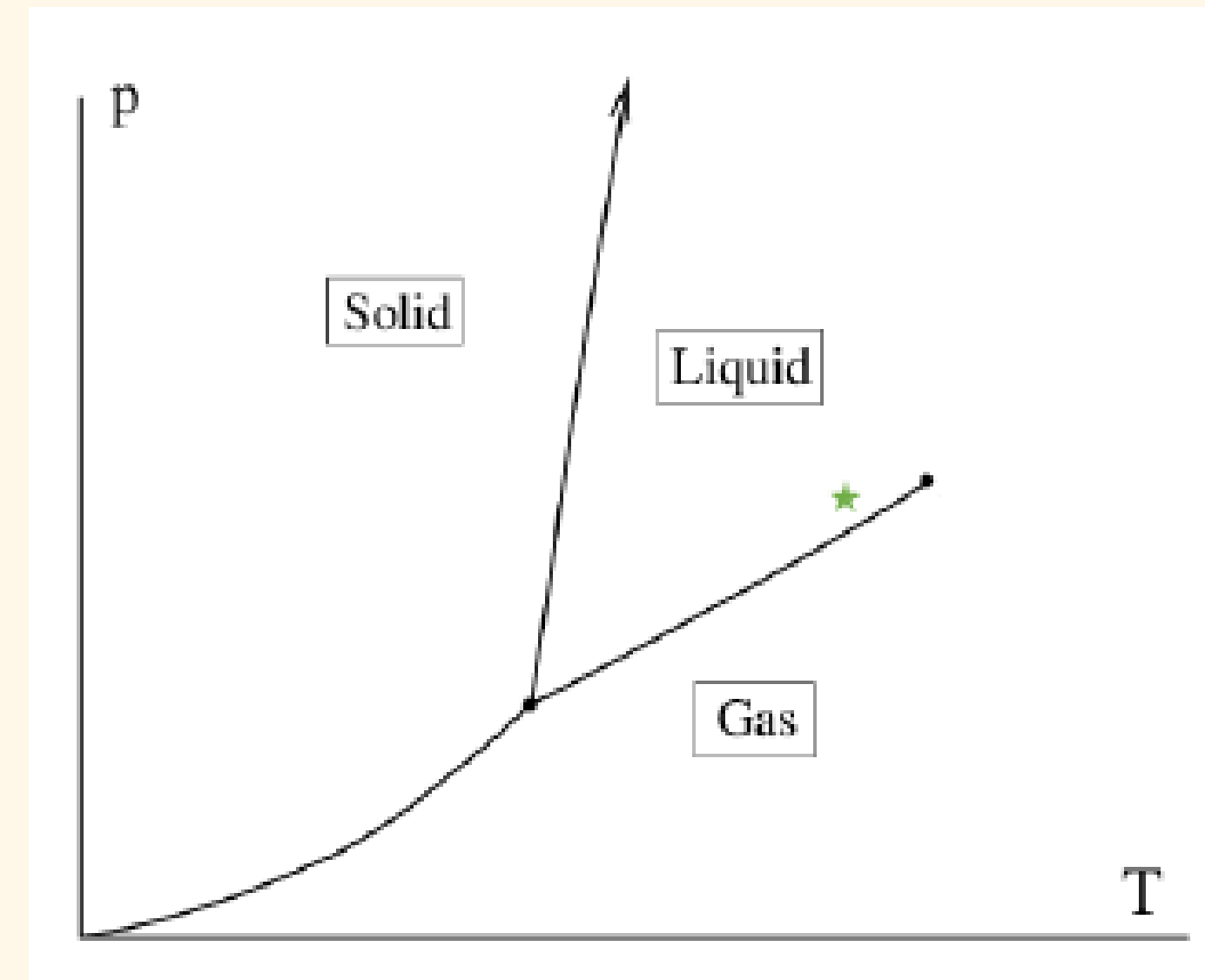
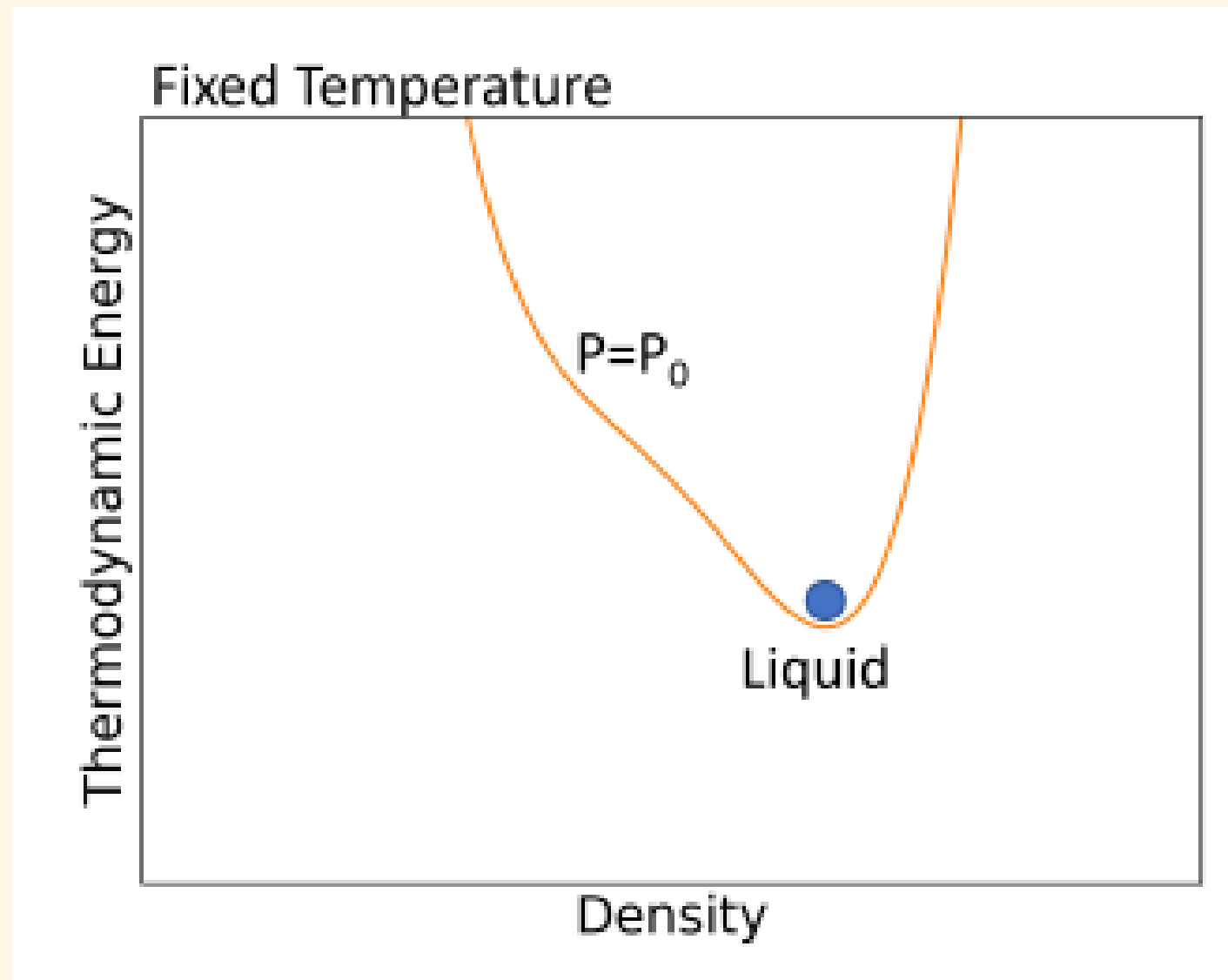

Compressed

Bubble Chambers as Particle Detectors

Lowering the pressure creates a secondary **metastable** state:
superheated fluid

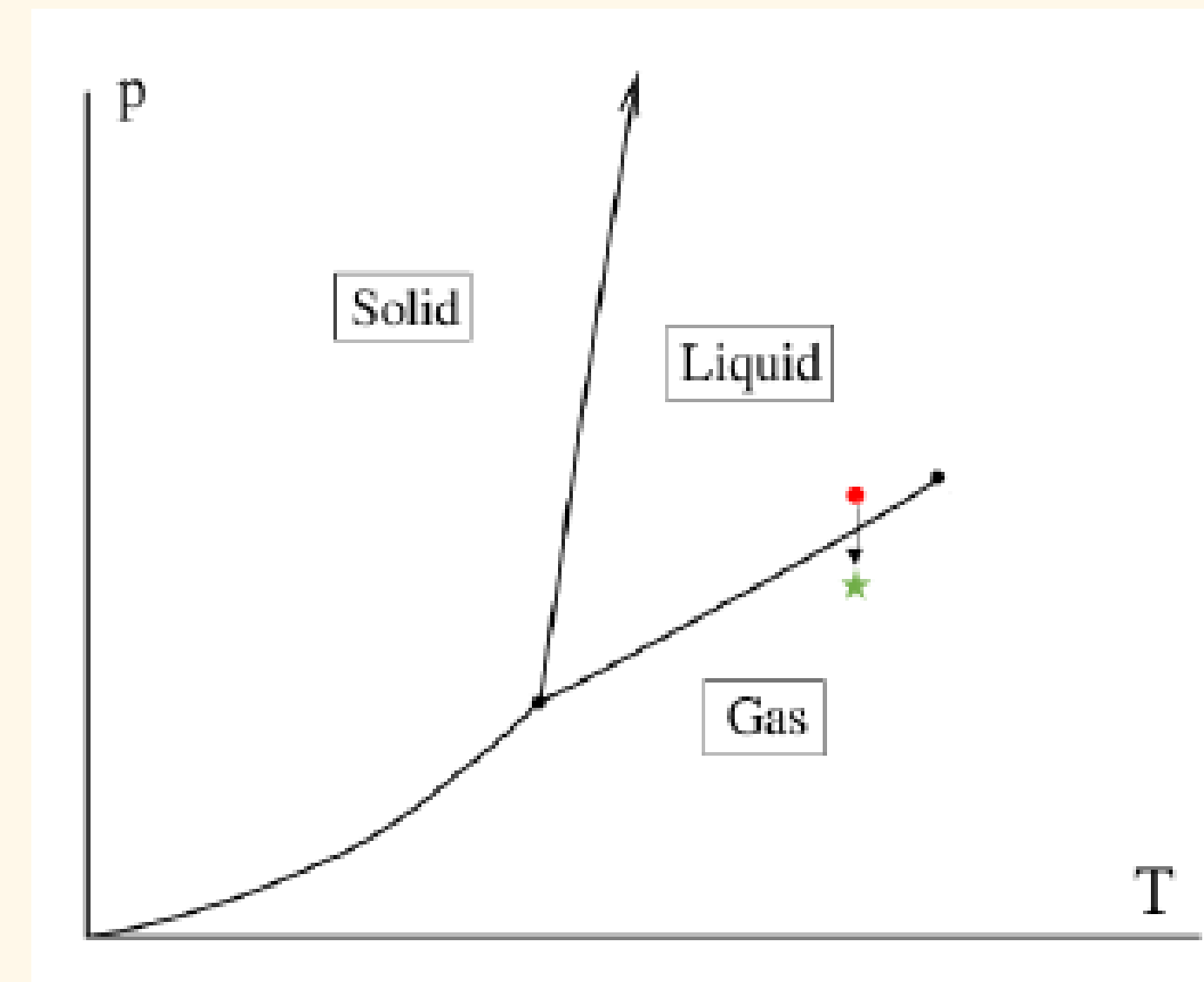
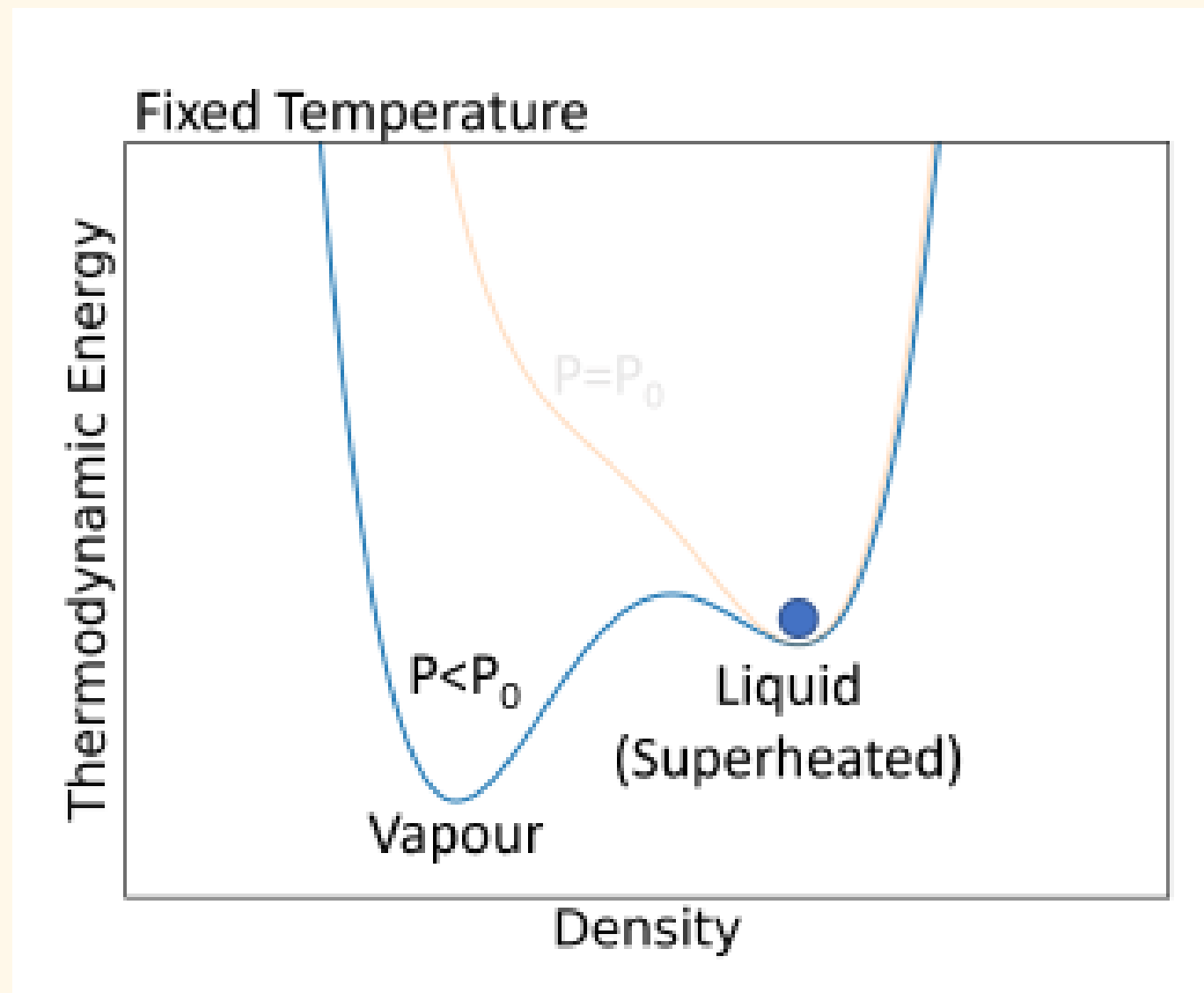

Expanded

Bubble Chambers as Particle Detectors

Energy threshold: **3.29 keV**

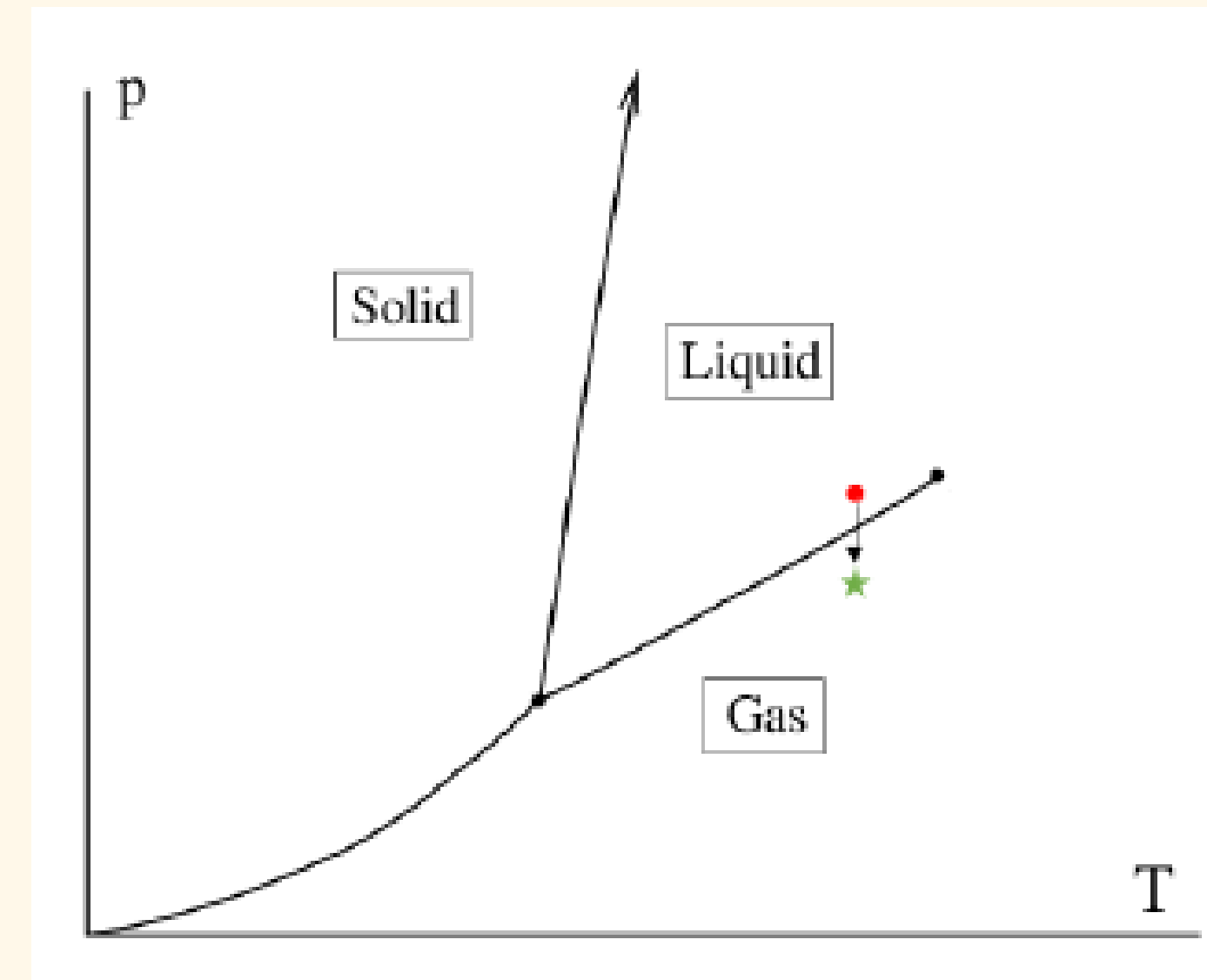
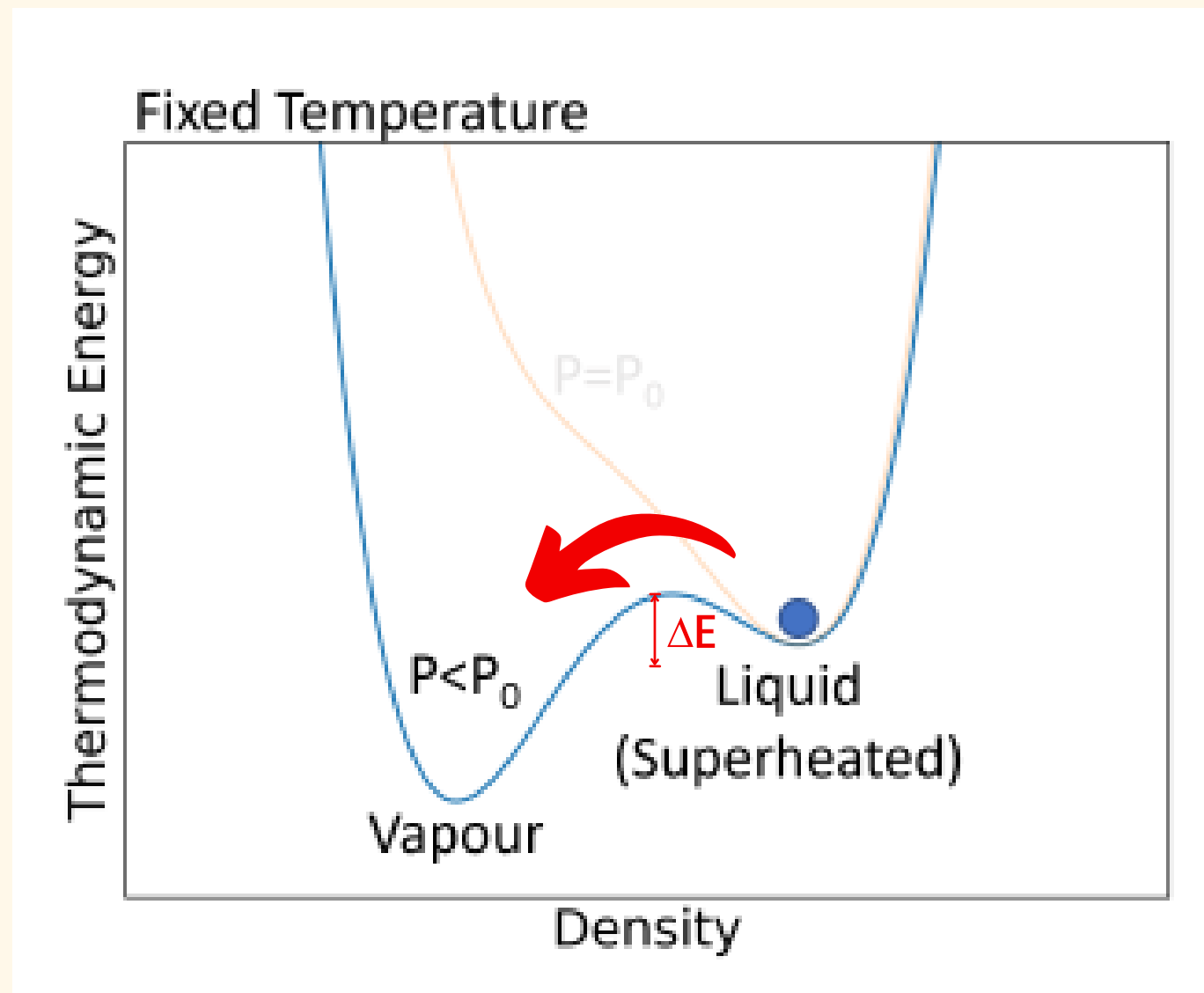

Expanded

PICO-500

- 250 L of Freon
- Will be located at SNOLAB
- Assembly has started last year

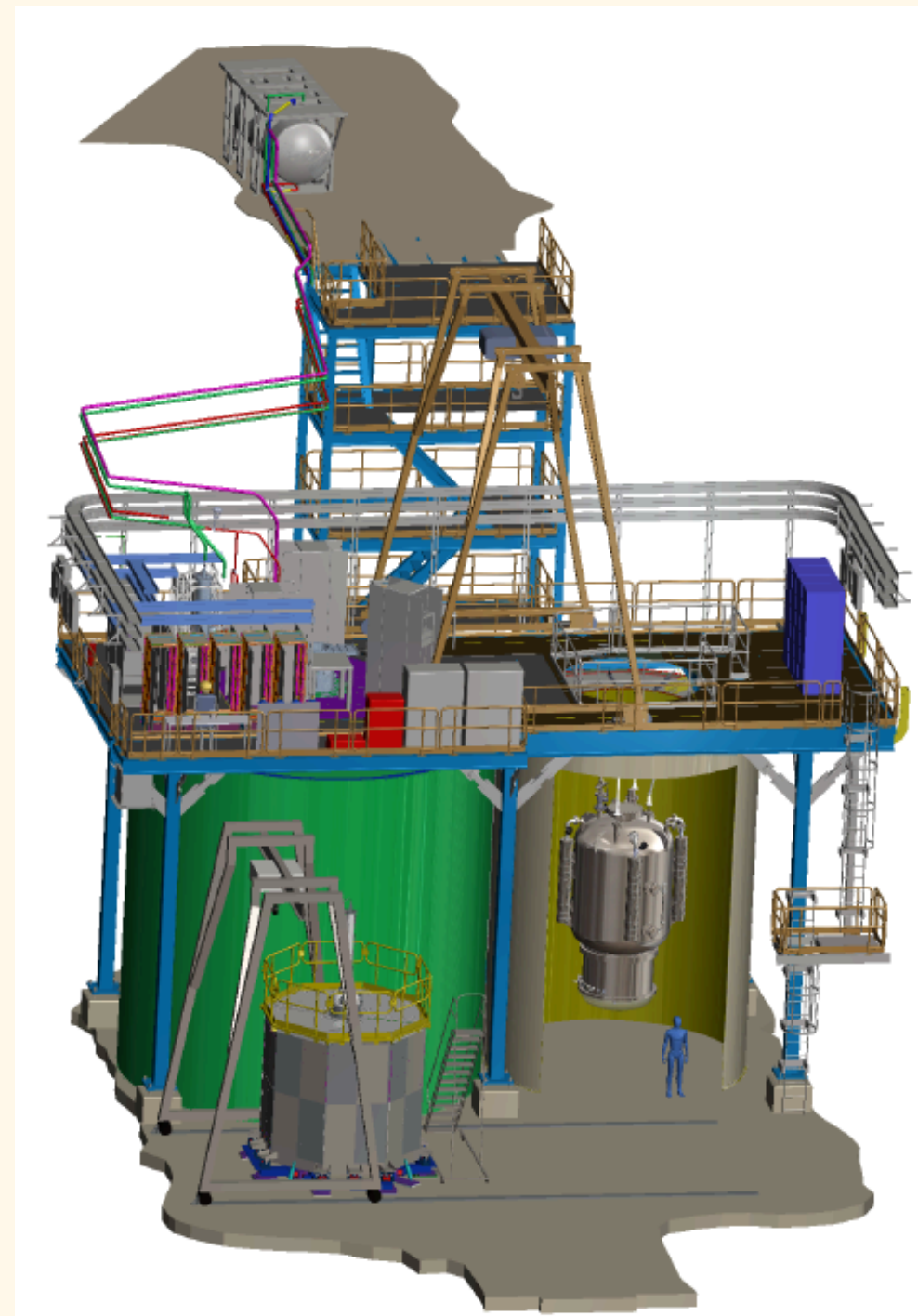

- **Largest quartz jar ever made.**
- **Better instrumentation** on all aspects.
- Improvements of the insulation for better temperature control.

PICO-500

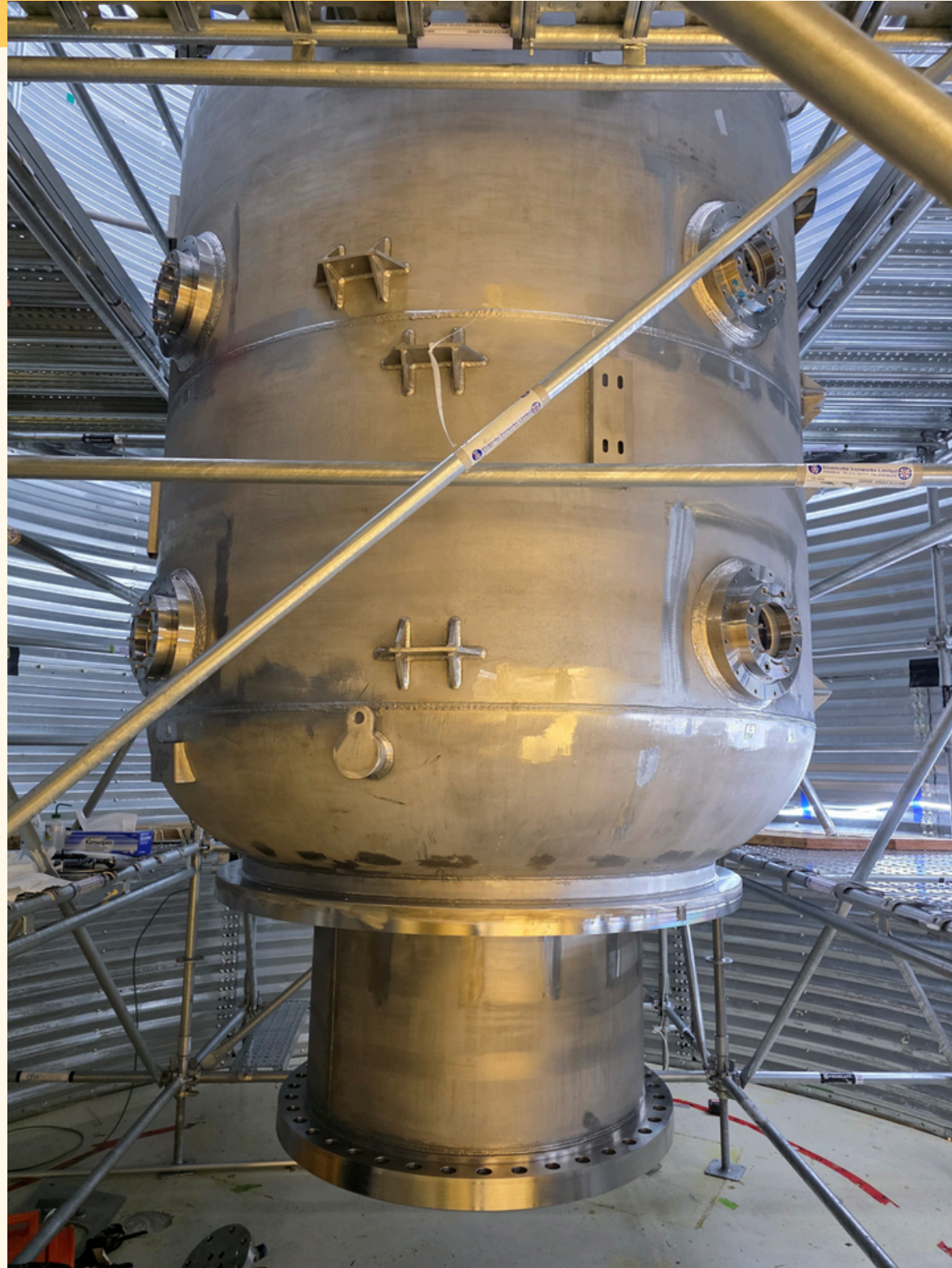

Background events

Alphas

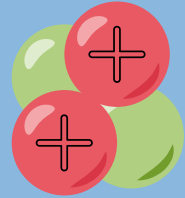

Neutrons



Electron
recoil

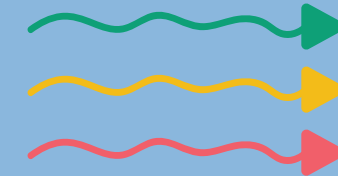

Background events

Alphas

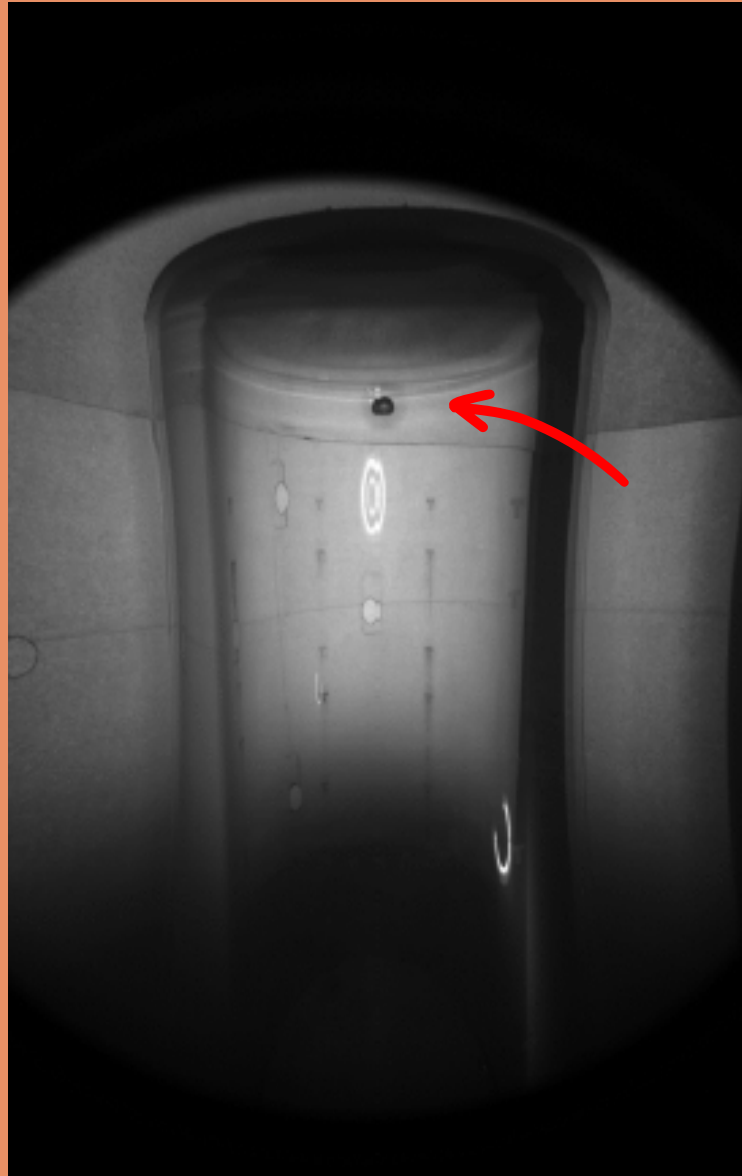
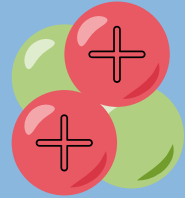

Single bubble

Neutrons



Electron
recoil

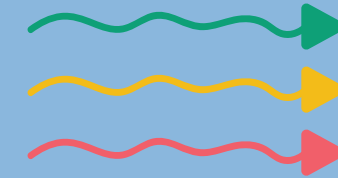

Background events

Alphas

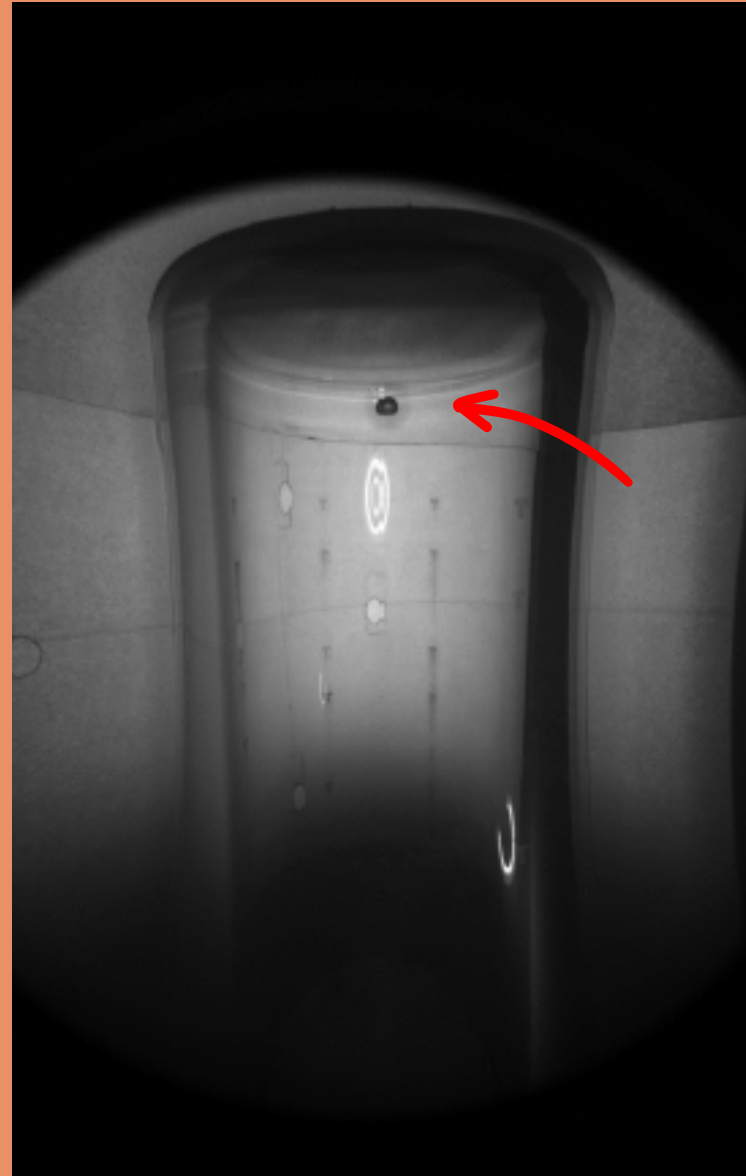
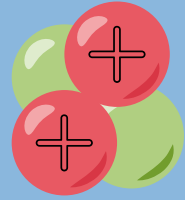

Single bubble

Neutrons

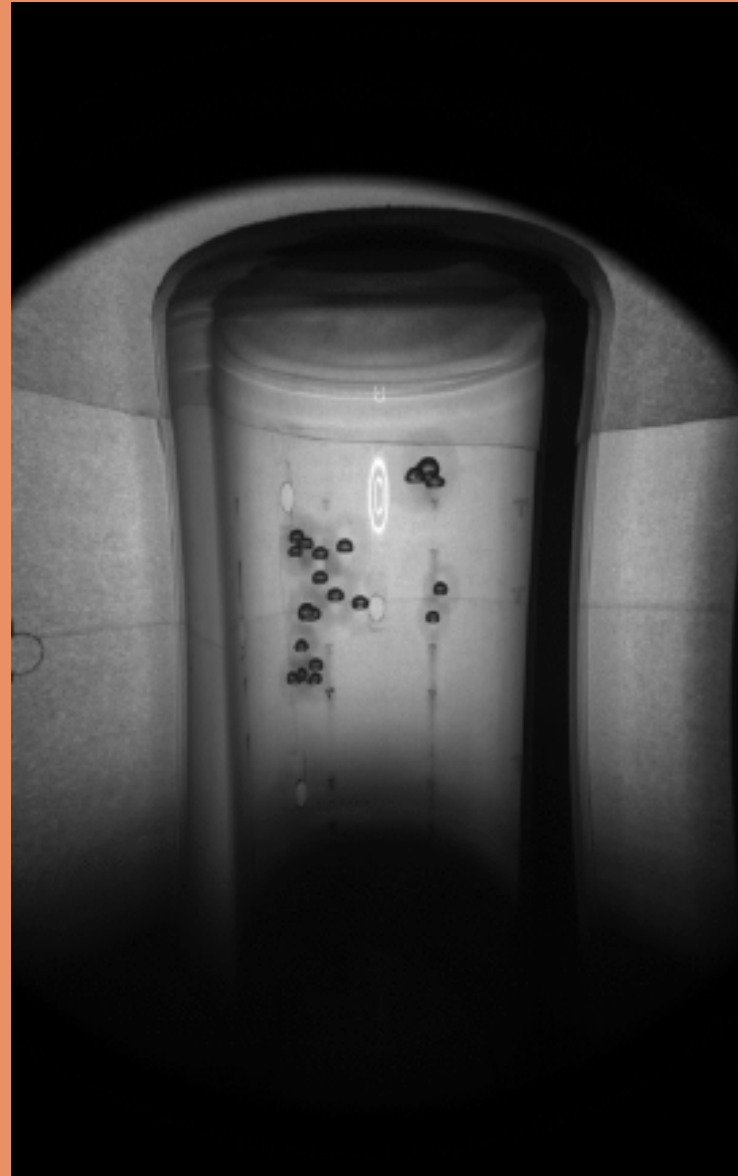

Multiple bubbles

Electron
recoil

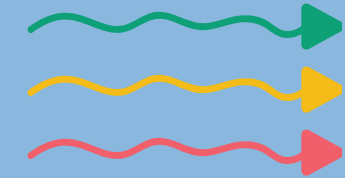

Background events

Alphas

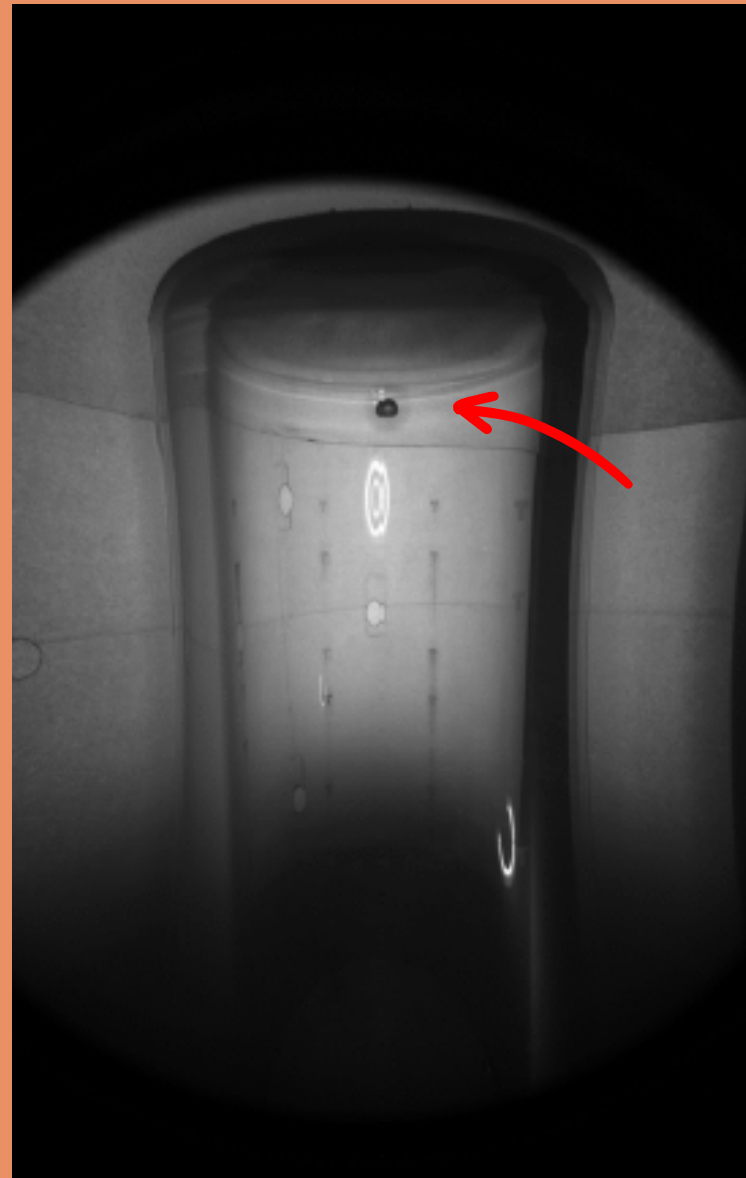
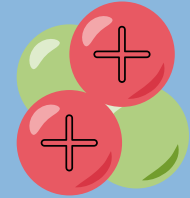

Single bubble

Neutrons

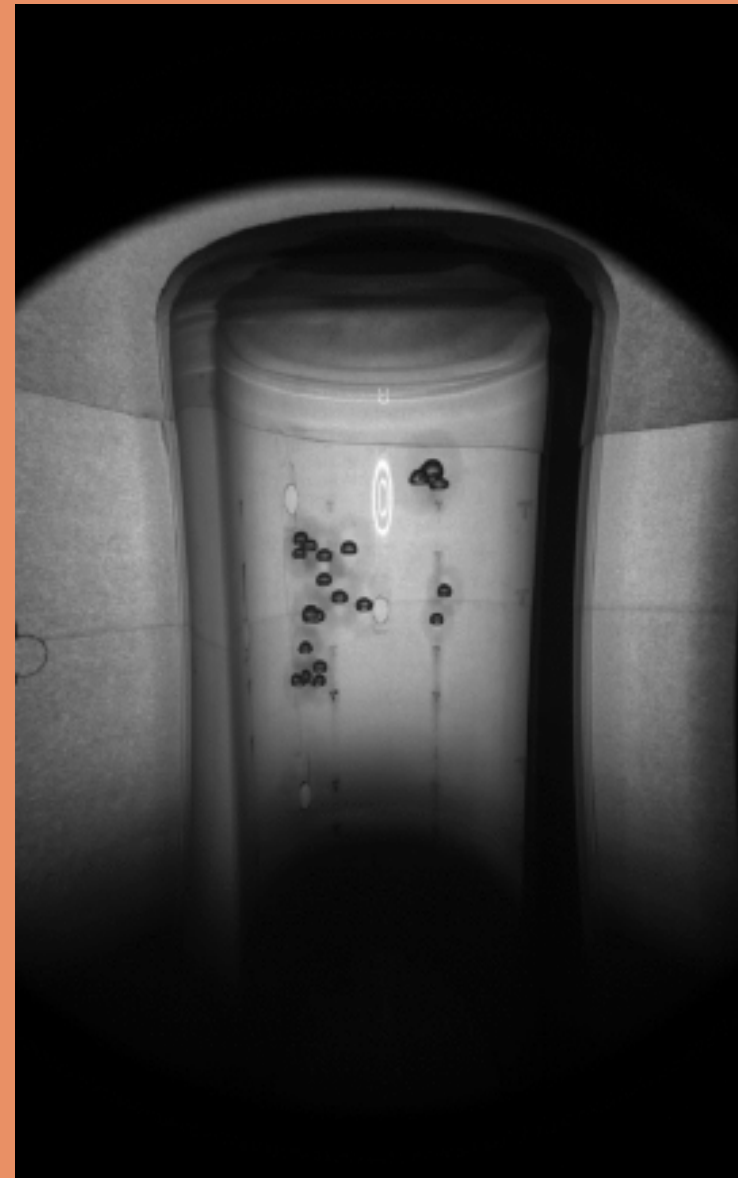

Multiple bubbles

Electron recoil

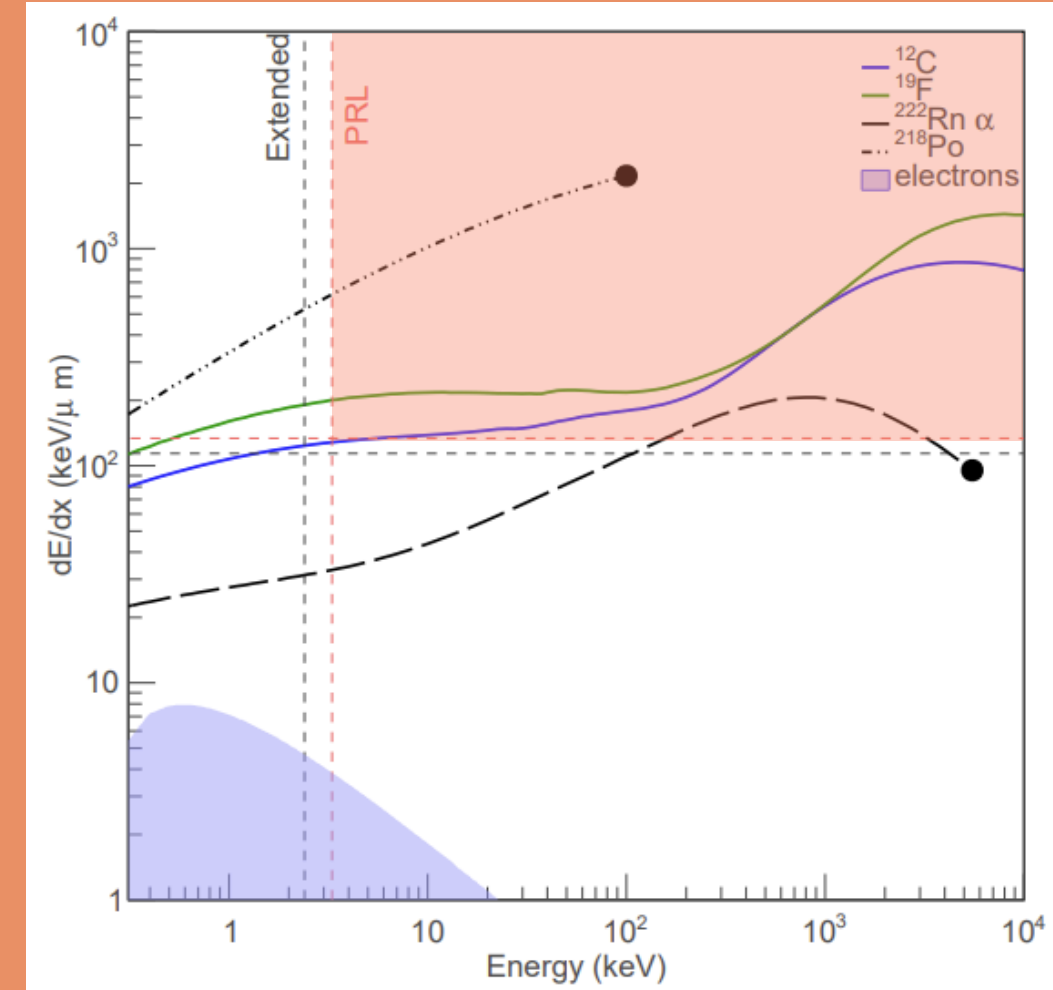

Insensitive

Source of alpha: Radon-222

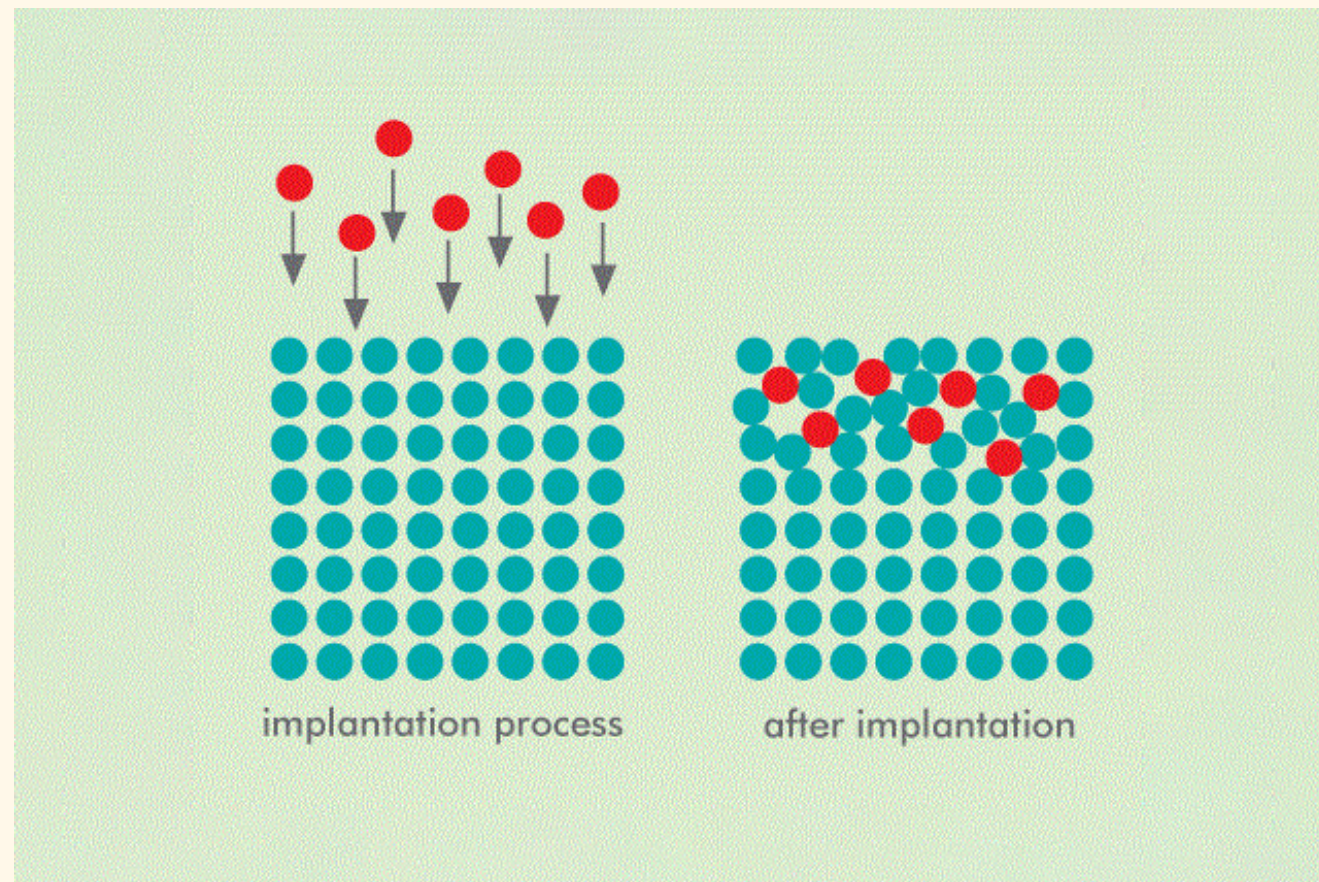

Stanford Advanced Materials

- **Radon will adsorb on the surface on materials.**
- It can then **decay, implanting its daughter a few micrometers** into the materials.

Source of alpha: Radon-222

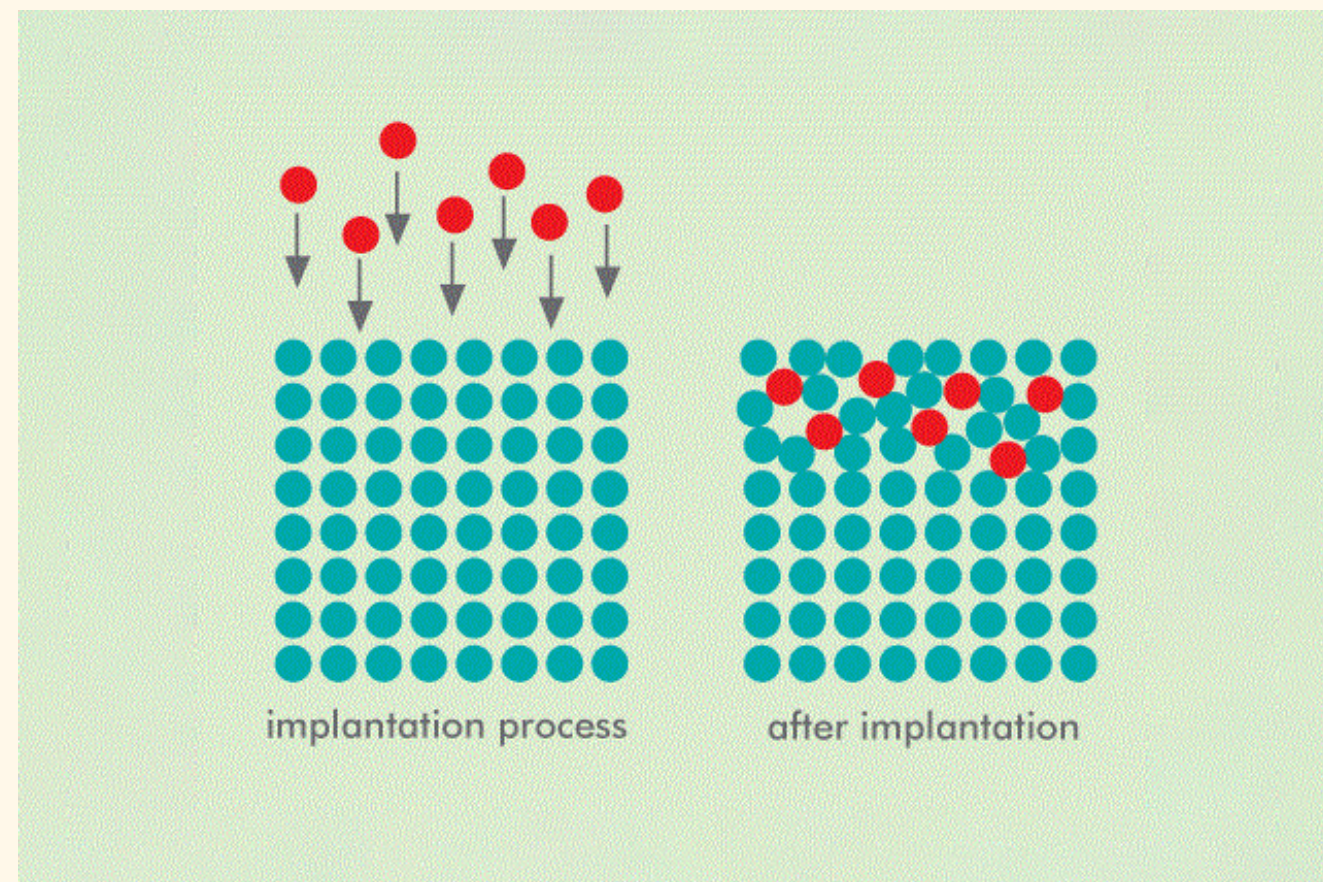

Stanford Advanced Materials

- Radon will adsorb on the surface on materials.
- It can then **decay, implanting its daughter a few micrometers** into the materials.

- **The longer the exposure, the more Pb-210 will build up near the jars surface.**
- Most efficient way to remove this contamination is acid etching.

Radon Mitigation



- Etching is not a possibility for PICO-500.
- We need to **avoid radon exposure on our jars.**
- A procedure was developed to follow during the assembly to reduce radon exposure.
- **Max exposure: <0.9 year**

Radon Mitigation

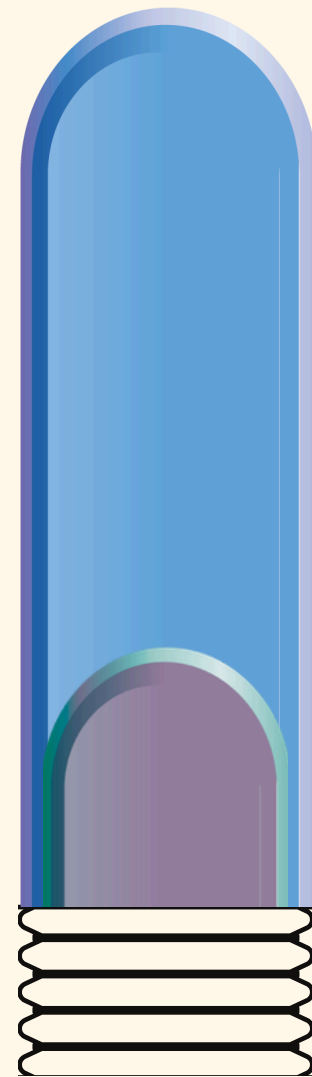
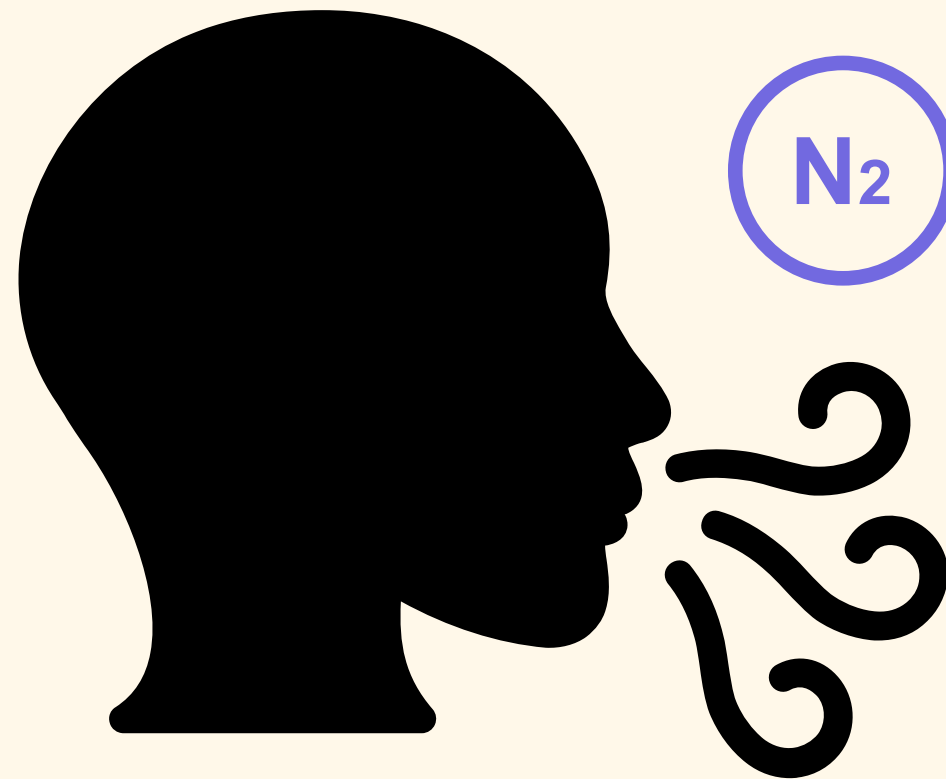

- Etching is not a possibility for PICO-500.
- We need to **avoid radon exposure on our jars.**
- A procedure was developed to follow during the assembly to reduce radon exposure.
- **Max exposure: <0.9 year**

- The procedure consists of covering the jars with **tight aluminum bags.**
- **Flow nitrogen** through the bag to push out radon.

Radon Mitigation

- A **bulkhead fitting** is used to flow gas through the bag.
- A simple **nitrogen purge** is done for the **inside target volume**.
- The **inside inner jar** is sealed using our cleaning apparatus.

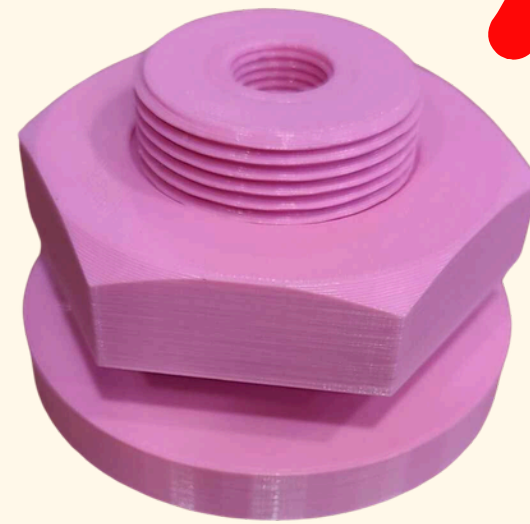

Radon Mitigation

- A **bulkhead fitting** is used to flow gas through the bag.
 - A simple **nitrogen purge** is done for the **inside target volume**.
 - The **inside inner jar** is sealed using our cleaning apparatus.
-
- An **EVOH bag** will be used for later after heating tower installation.



Radon Mitigation

$$V \frac{\partial C}{\partial t} = A \frac{D(C_{out} - C)}{l^2} - JC - \lambda_{Rn} VC$$



Permeation



Nitrogen flush



Radon decay

- For an **aluminum** bag, the **radon permeation is negligible**.
- Radon will come in from the fitting and the elastic at the bottom.
- For a given nitrogen flush, we can **calculate the equilibrium concentration**.

Radon Mitigation

Current estimates put our exposure to 12.1 days since we **unboxed the jars 609 days ago.**
Still ongoing!!

Main contributions:

- **Dewar changes**
- **New Year holidays**
- Assembly
- Resealings after assembly

Radon Mitigation

Current estimates put our exposure to 12.1 days since we **unboxed the jars 609 days ago.**
Still ongoing!!

Main contributions:

- **Dewar changes**
- **New Year holidays**
- Assembly
- Resealings after assembly

- It is **difficult to measure the effectiveness of the mitigation technique without impacting its cleanliness.**
- **Radon assay results** have shown that the inside surface has **low radon contamination.**
- The best way is to calculate the event rate of PICO-500 after a year of data taking compared to previous detectors.

PICO-500

Timeline

- Construction well underway.
- **Detector systems to be installed later this year.**
- Fluid fill in early 2027.
- **Commissioning start in mid-late 2027.**



Conclusion



Credit: Lily Hines, MI/PICO

- Bubble chambers can be **effectively insensitive to electron recoil.**
- **Radon is one of the most important background** for the next generation of low background experiments.
- **Radon mitigation techniques will become more critical** as sensitivity improves.
- Simple and effective solutions do in fact exist.

Thanks for listening!



R. Filgas, D. Mamedov,
E. Rukhadze, I. Stekl



D. Priya, S. Priya, Y. Yan



C.E. Dahl



P. Grylls, A. Mathewson,
I. Lawson, S. Sekula



O. Harris



P.S. Cooper, M. Crisler,
A. Sonnenschein



R. Neilson



A. Acevedo-Rentería,
A. García-Viltres,
E. Vázquez-Jáuregui



Kavli Institute
for Cosmological Physics
at The University of Chicago

J.I. Collar



M. Baker, S. Fallows,
C. Krauss, Q. Malin, S. Miller,
M. Rangen, C. Rethmeier,
P. Welingampola



Pacific Northwest
NATIONAL LABORATORY

I. Arnquist, C.M. Jackson,
B. Loer



E. Adams, M. Bai, K. Clark,
D. Cranshaw, K. Dering,
G. Giroux, H. Herrera,
C. Moore, A. Noble, M. Robert



I. Brooklyn Varela, L. Desmmarais,
P. Frédérick, M. Laurin, V. Monette,
H. Nozard, A. Robinson, J. Savoie,
N. Starinski, V Zacek, C. Wen Chao



J. Farine, A. Le Blanc,
C. Licciardi, U. Wichoski



J. Basu, M. Das,
V. Kumar



INDIANA UNIVERSITY
SOUTH BEND

E. Behnke, C. Cripe,
I. Levine,

Bubble Chambers as Particle Detectors

- **Bubble = Trigger**
- Collect the data, then recompress to start a new cycle.

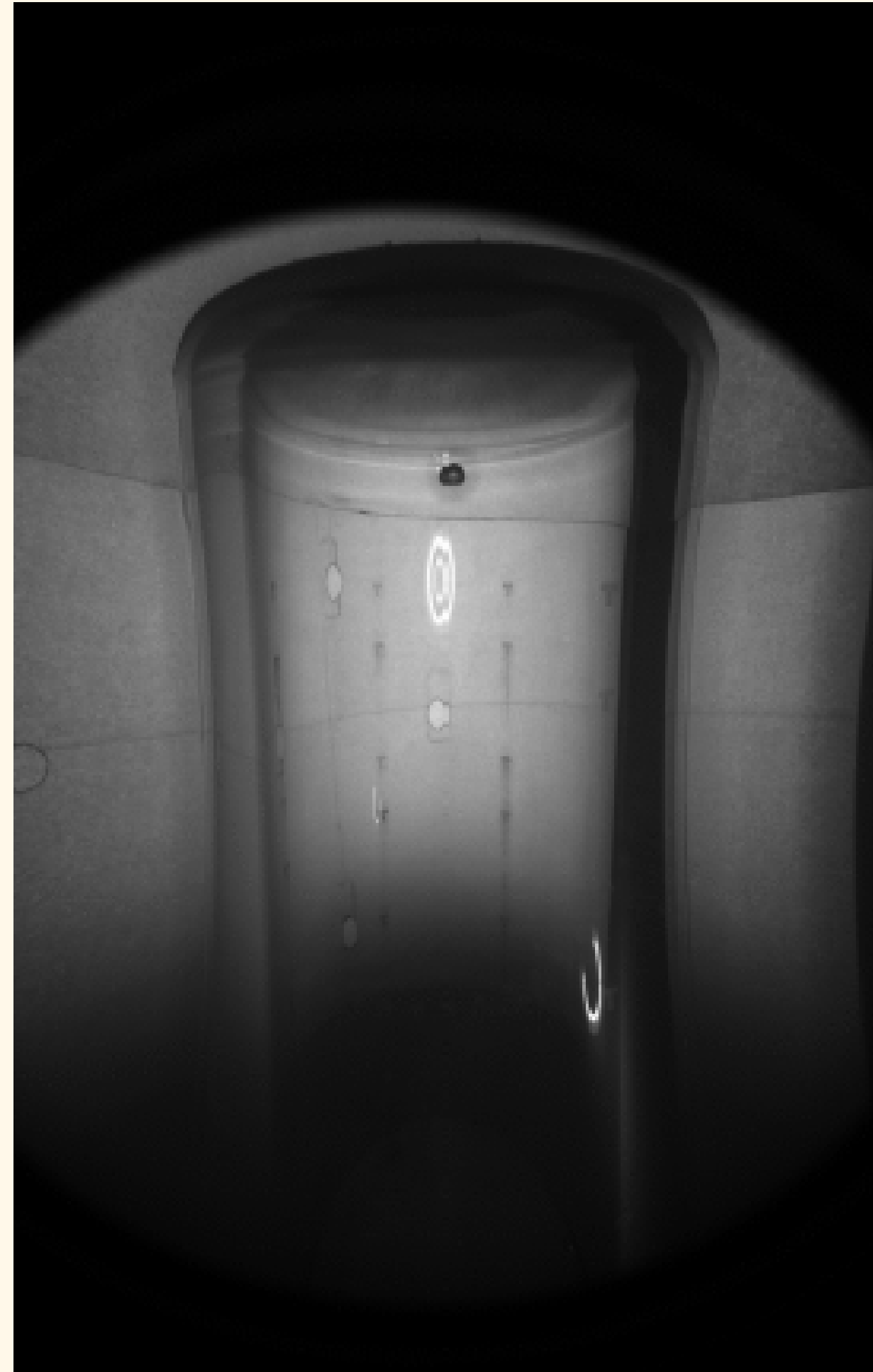

Bubble Chambers as Particle Detectors

- **Bubble = Trigger**
 - Collect the data, then recompress to start a new cycle.
-
- Before restarting the cycle, we wait for the thermodynamic properties to stabilize.



Position Reconstruction

- Stereoscopic images allows **3D reconstruction**
- **Spatial resolution of around 1 mm**

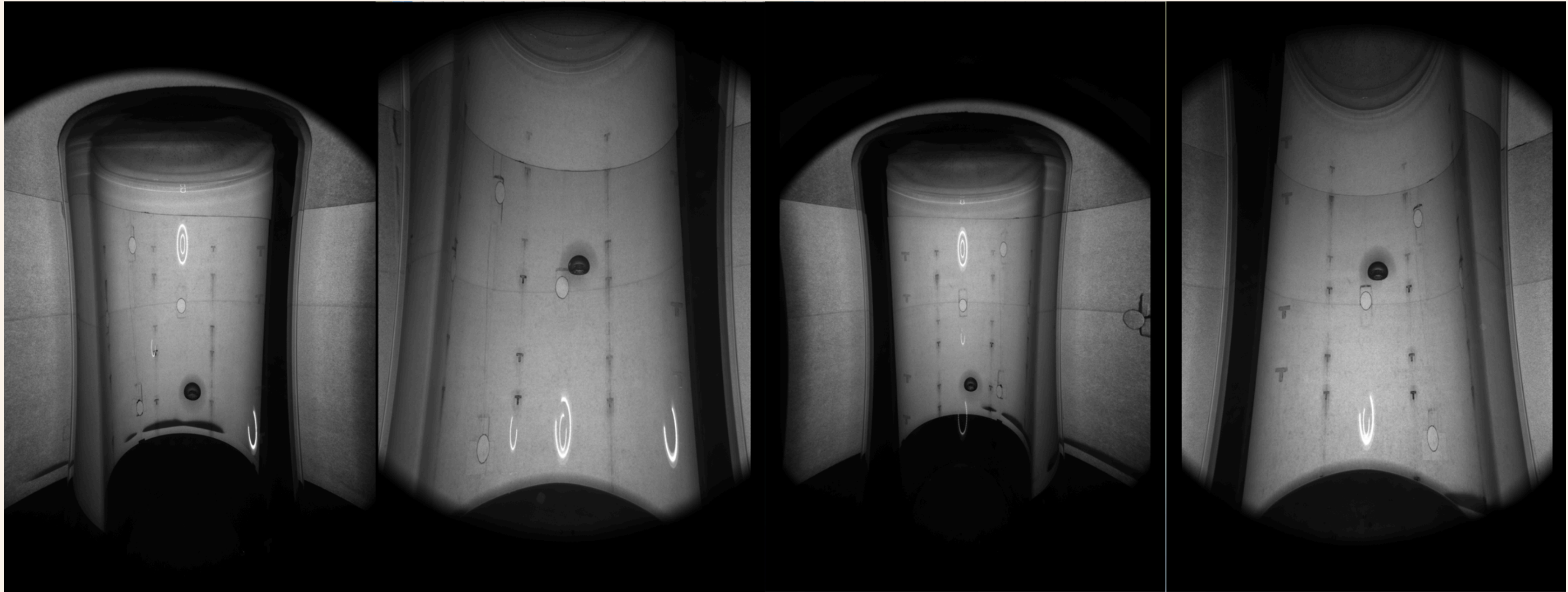

PICO-500

Projected Sensitivity

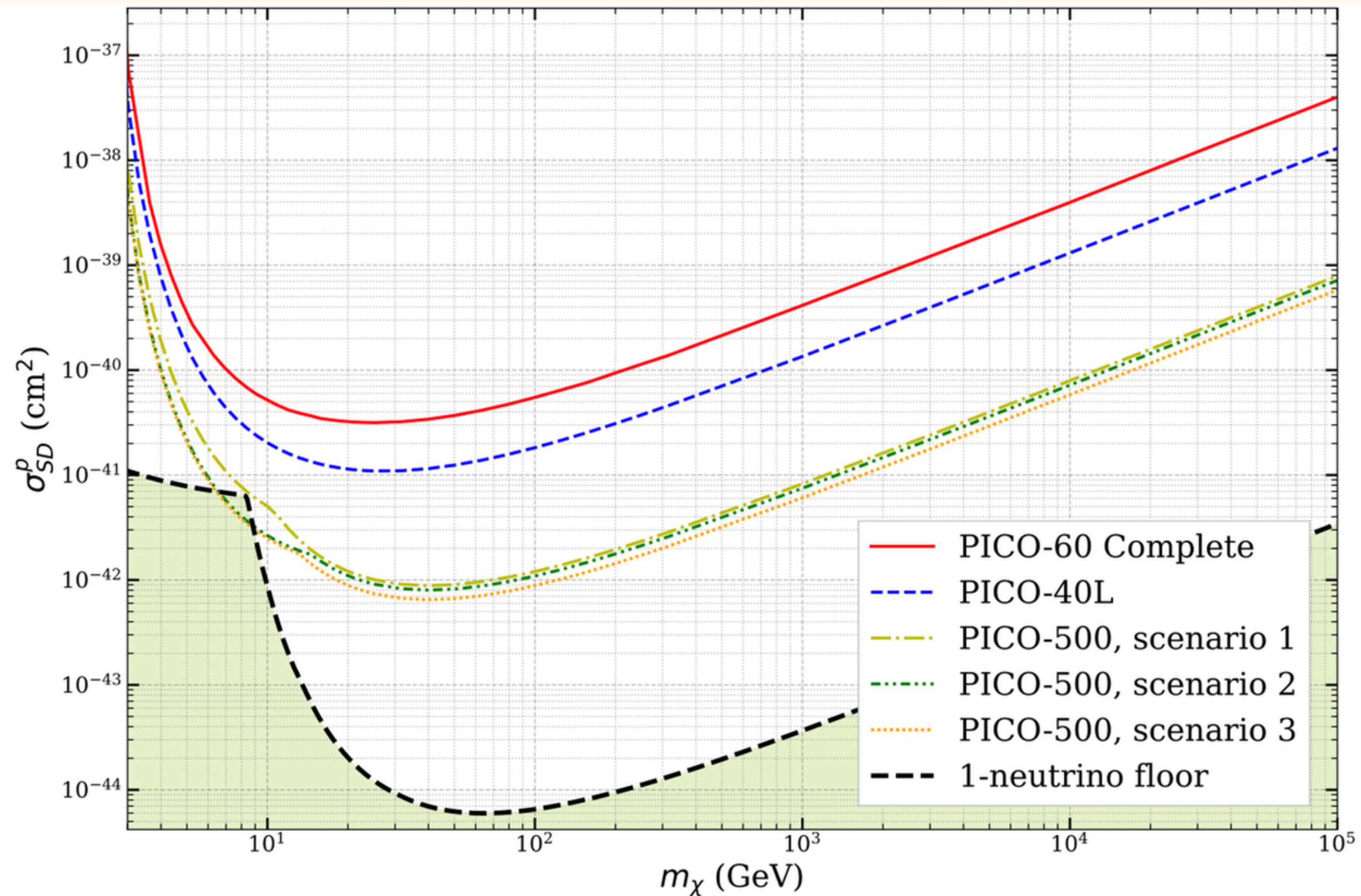

Credit: Colin Moore, PhD Thesis, 2024.

Position Reconstruction

- Stereoscopic images allows **3D reconstruction**
- **Spatial resolution of around 1 mm**

Z vs R^2

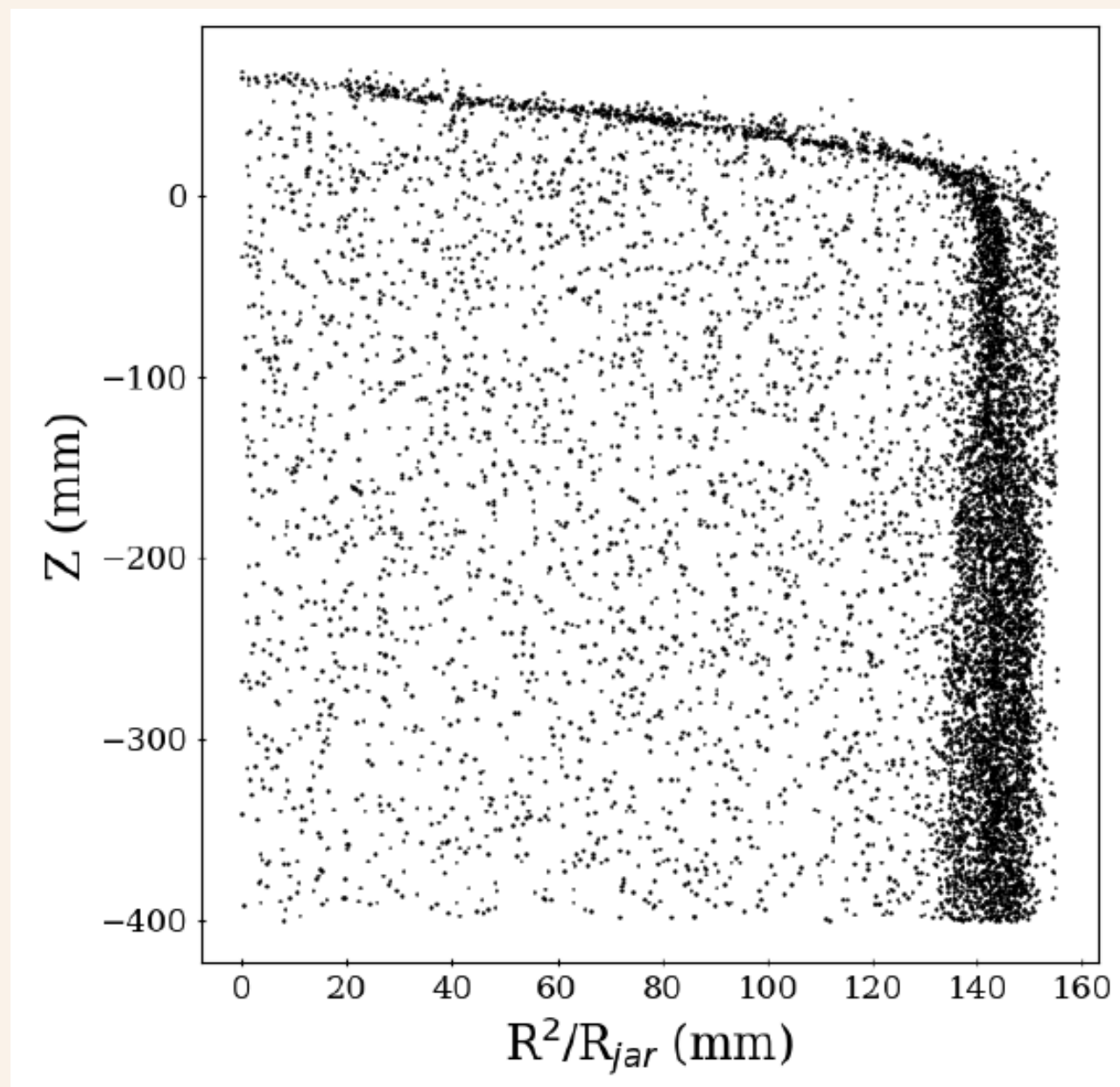

X vs Y

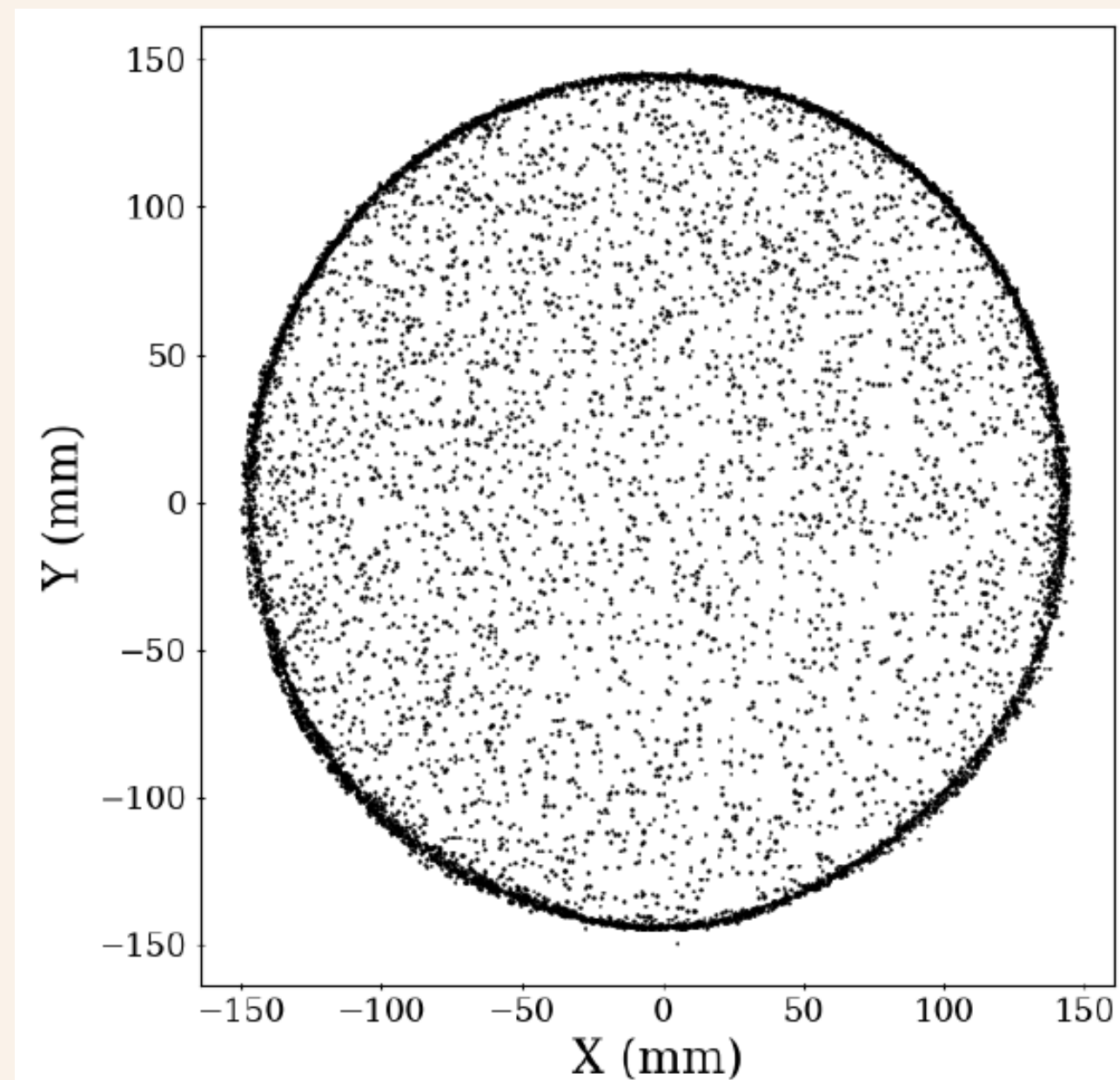

Particle ID with Acoustics

- 12 Piezos sensors at the bottom of the jar measure acoustic signals
- Magnitude of **acoustic signal allows for particle discrimination**

Raw Signal

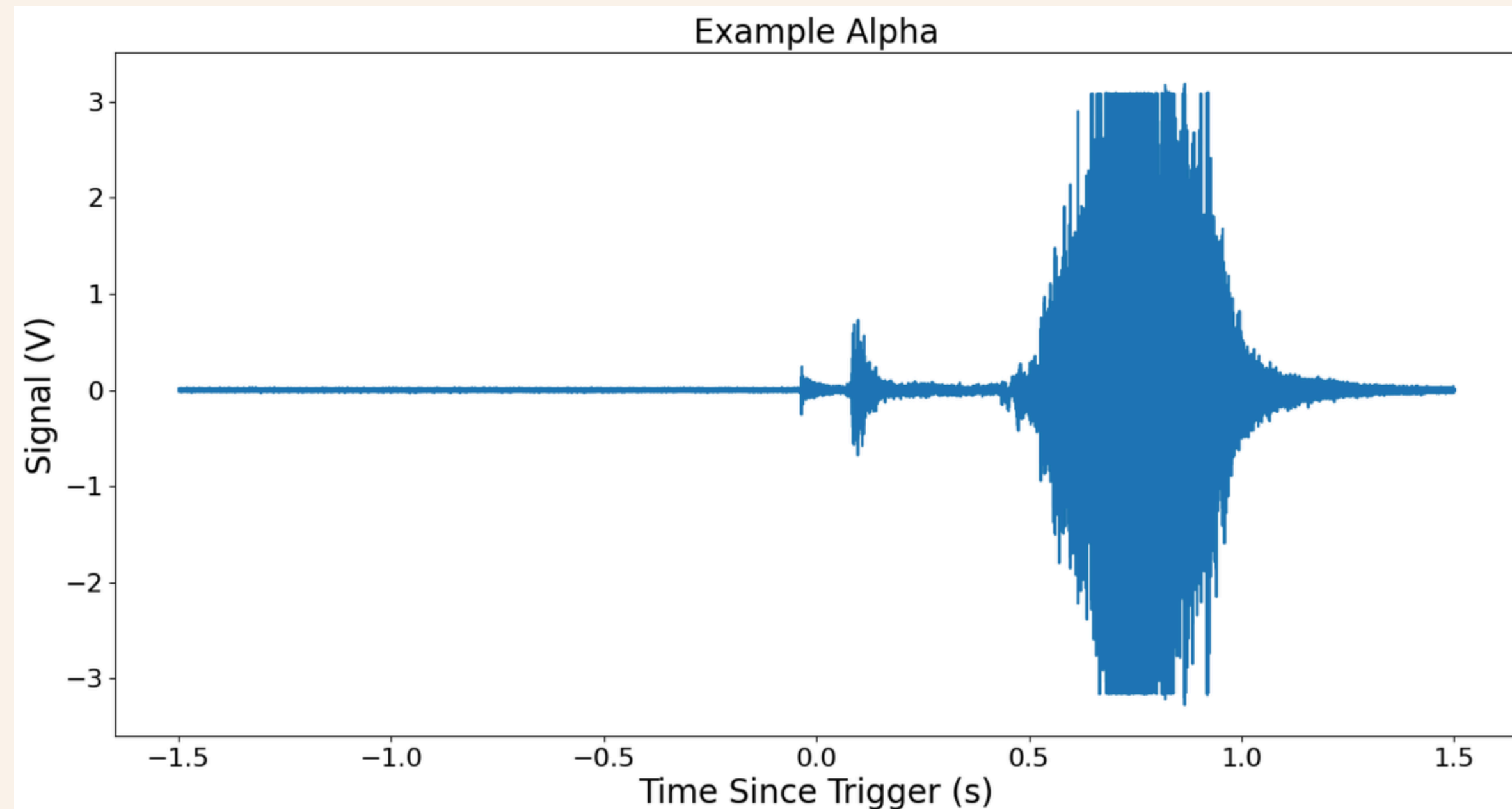

Particle ID with Acoustics

- 12 Piezos sensors at the bottom of the jar measure acoustic signals
- Magnitude of **acoustic signal allows for particle discrimination**

Raw Signal

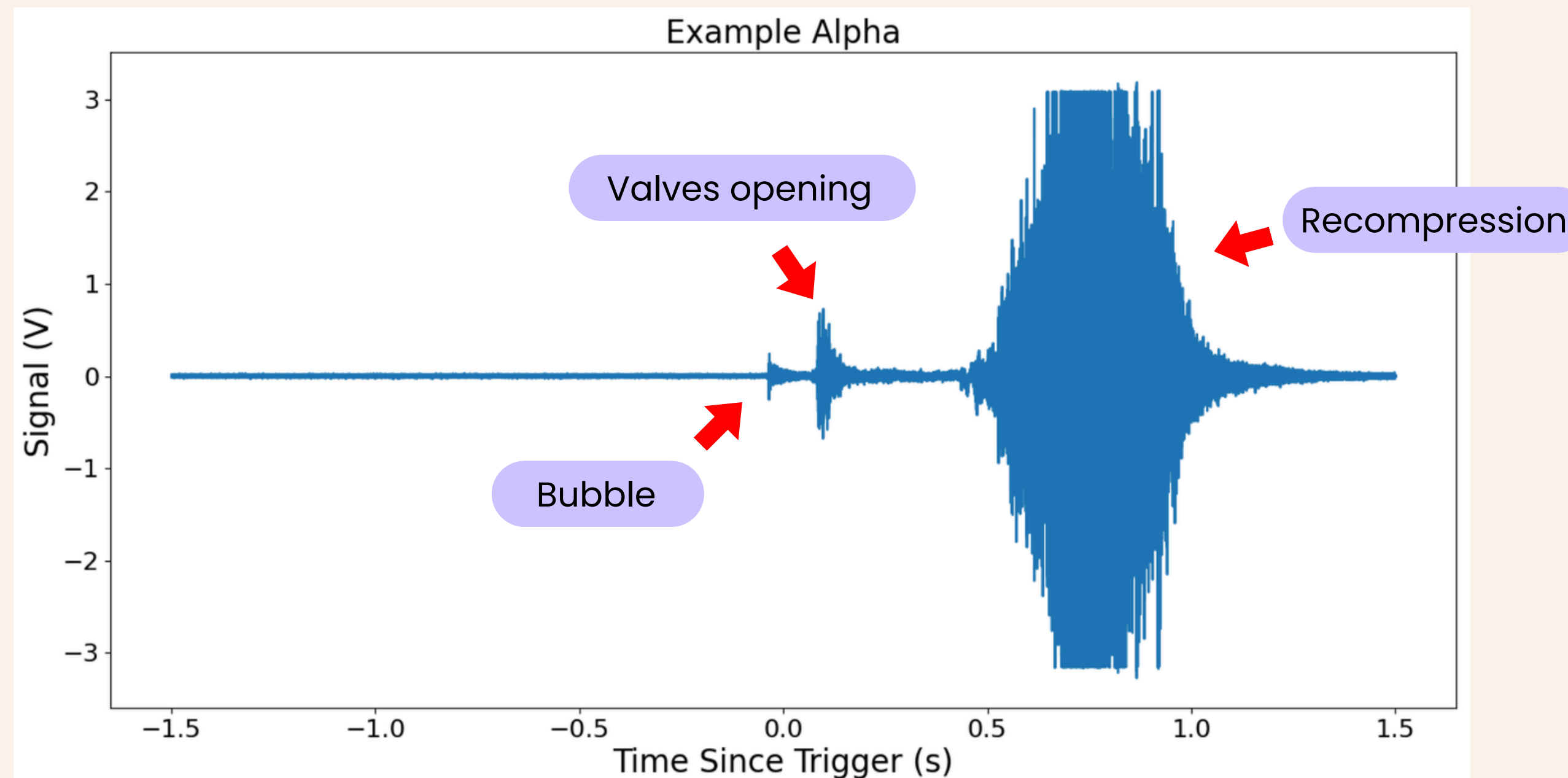

Particle ID with Acoustics

- 12 Piezos sensors at the bottom of the jar measure acoustic signals
- Magnitude of **acoustic signal allows for particle discrimination**

Raw Signal

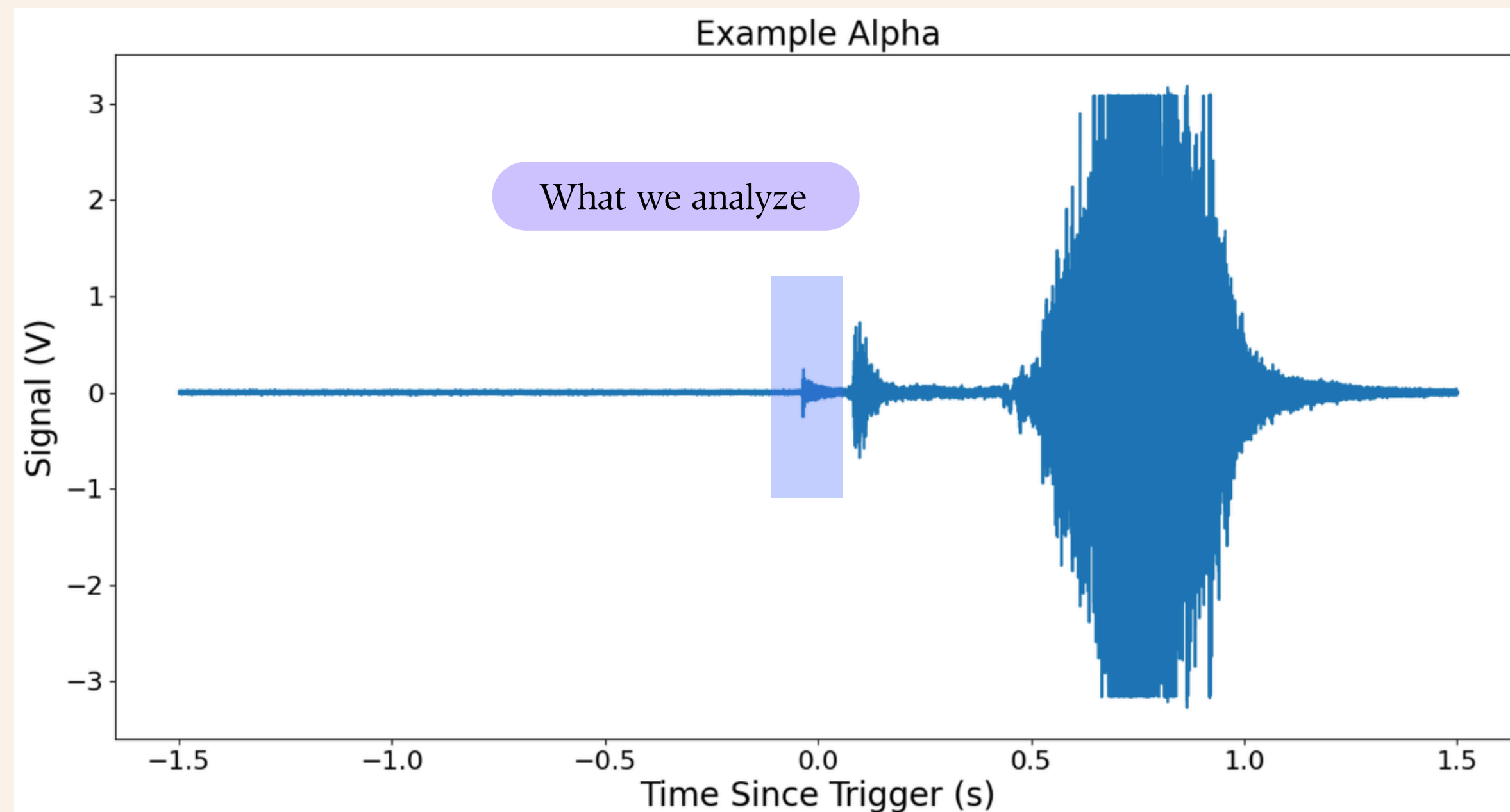

Particle ID with Acoustics

- 12 Piezos sensors at the bottom of the jar measure acoustic signals
- Magnitude of **acoustic signal allows for particle discrimination**

Raw Signal

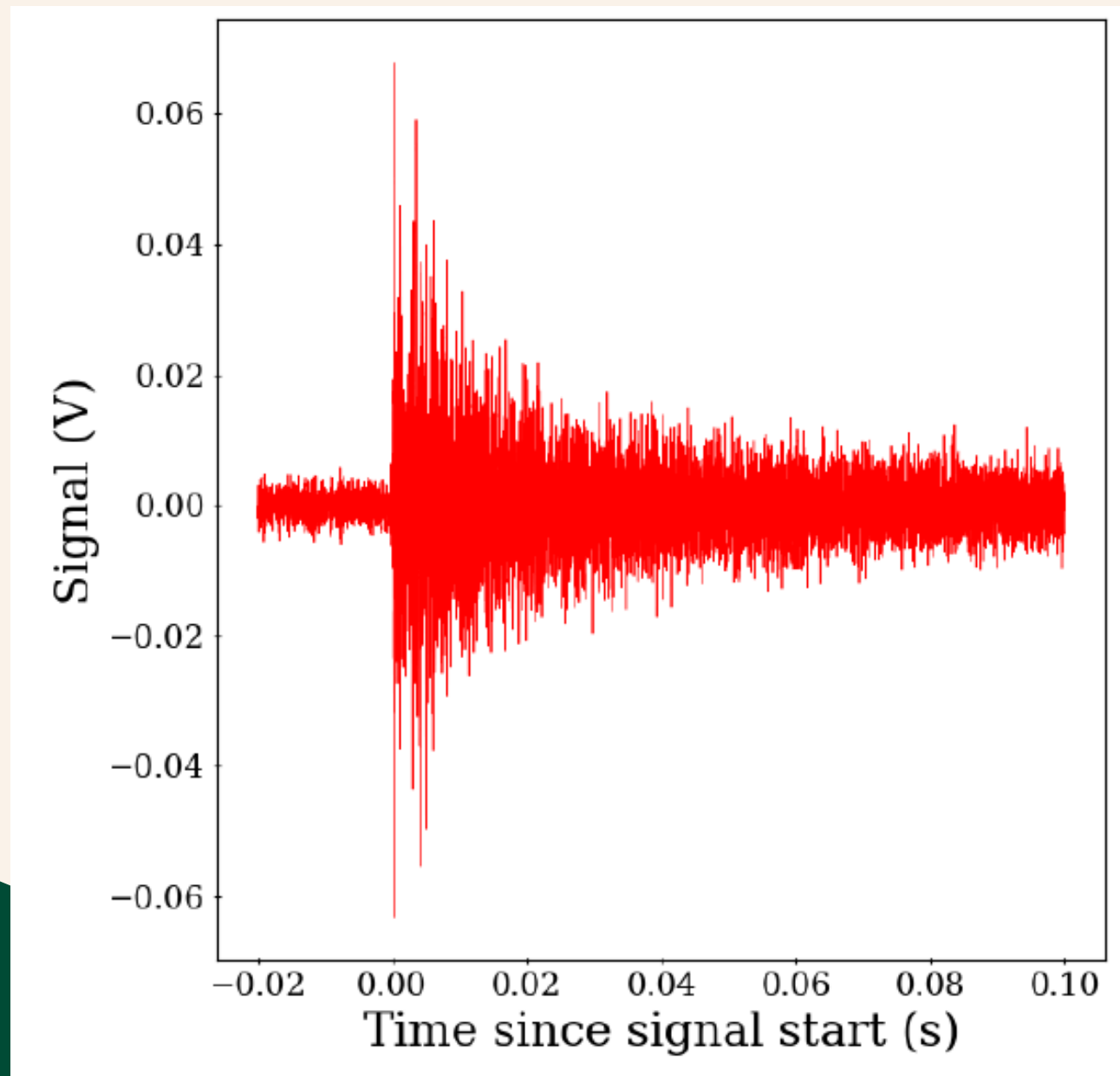

Acoustic Parameter

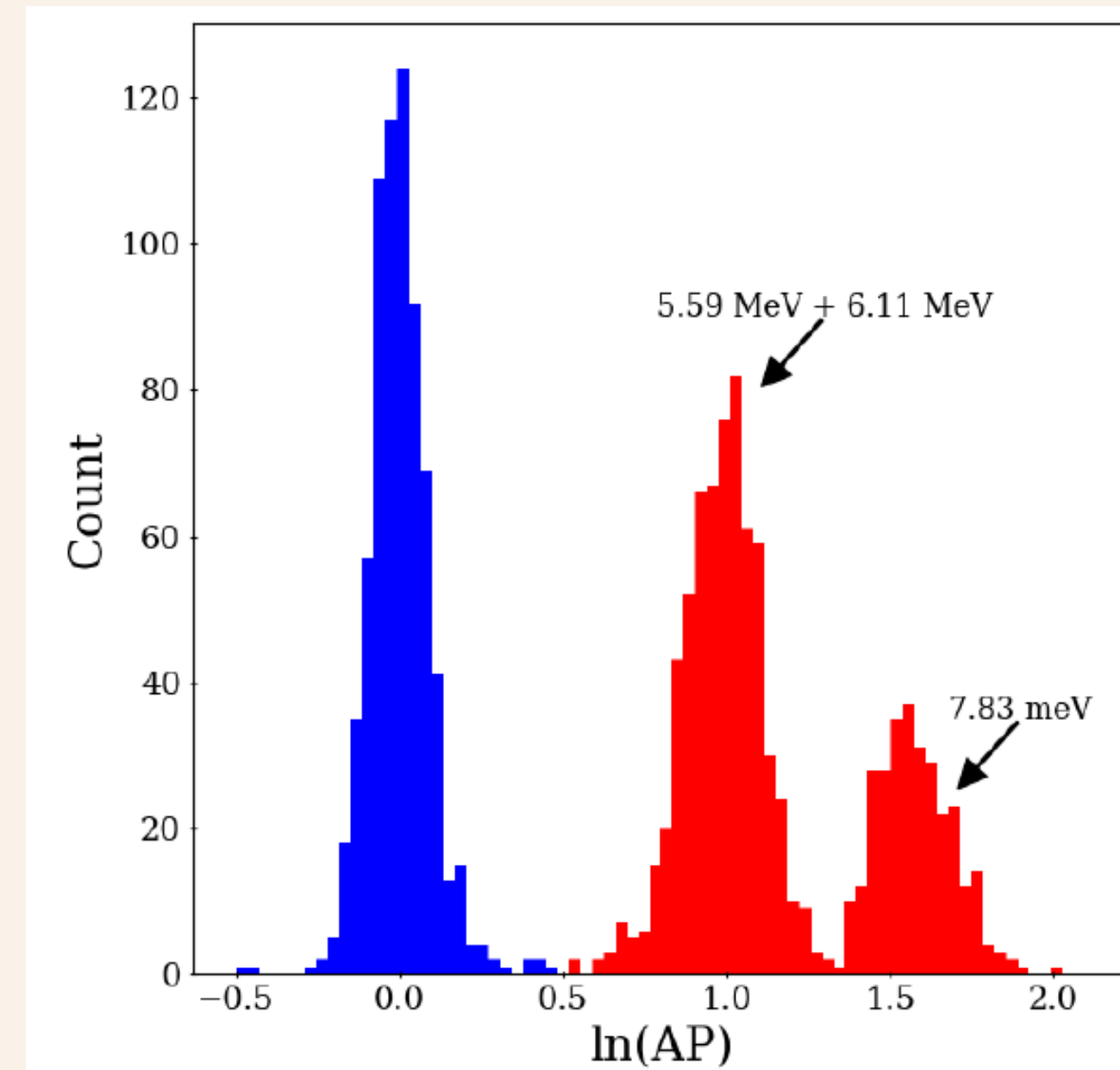

Bubble counting with Dytran

- Dytran: Fast pressure transducer. Measures change in pressure
- Dytran signal allows for precise bubble counting

Filtered Dytran

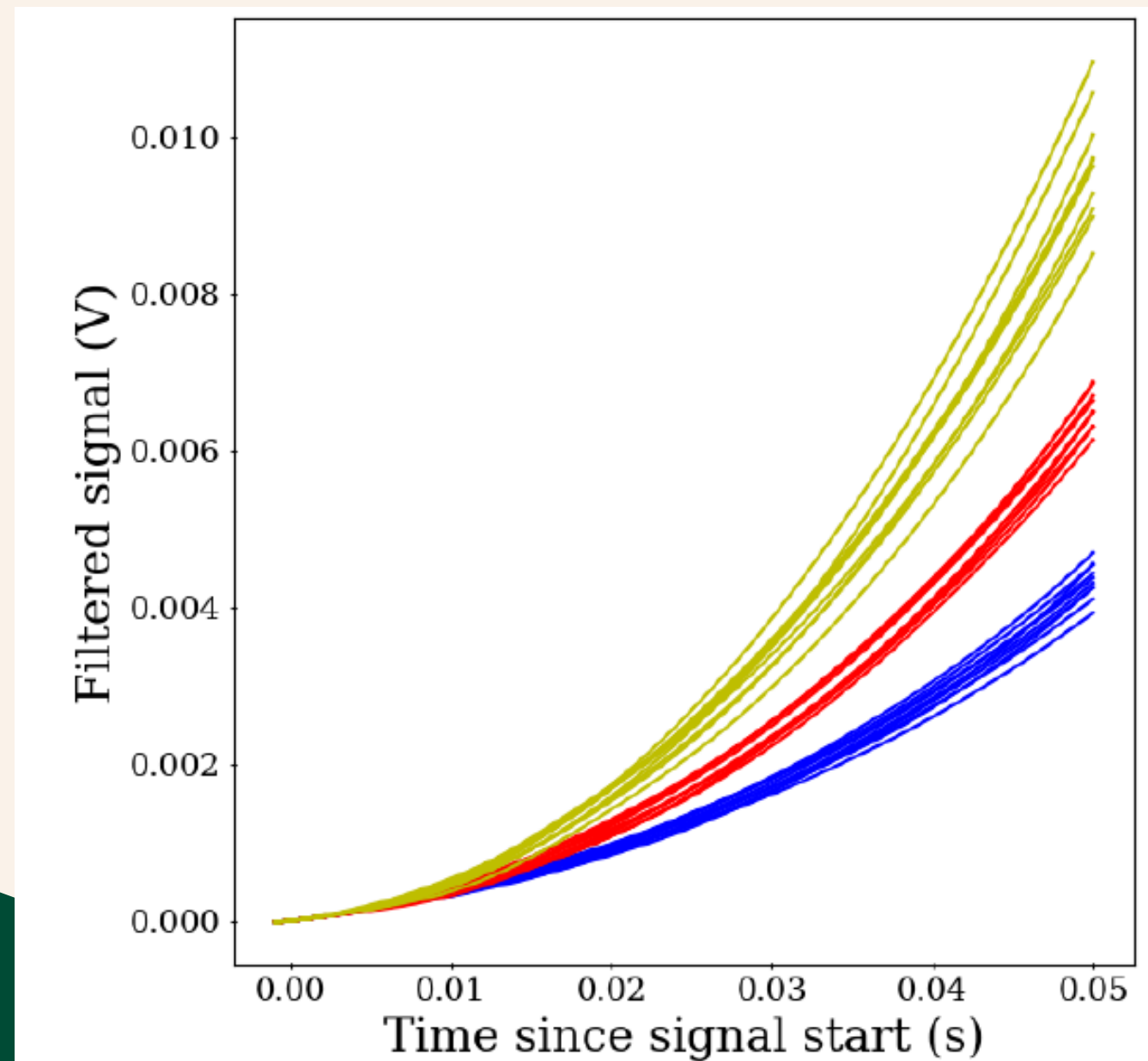

Corrected Dytran

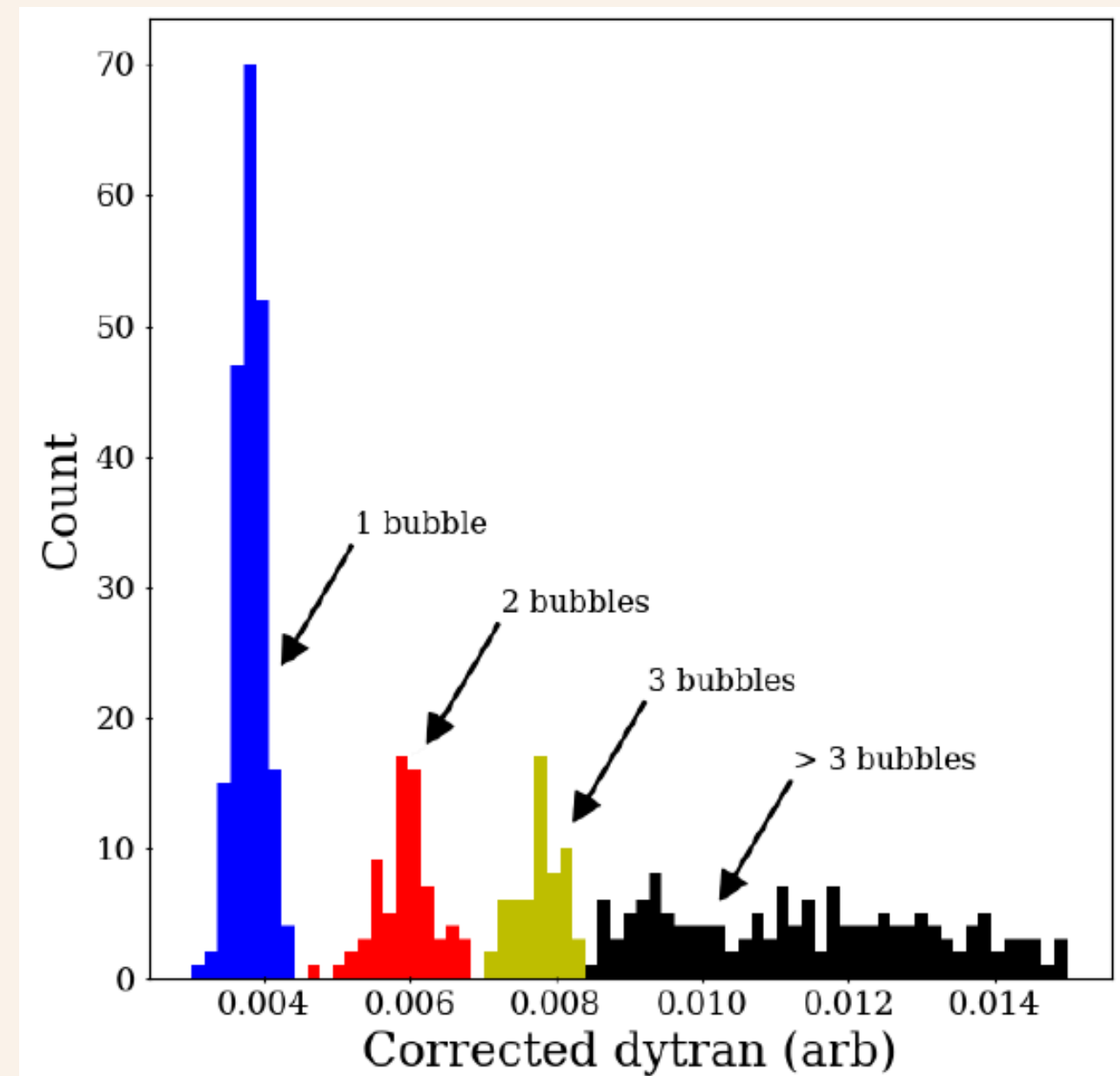

Why bubble chambers?

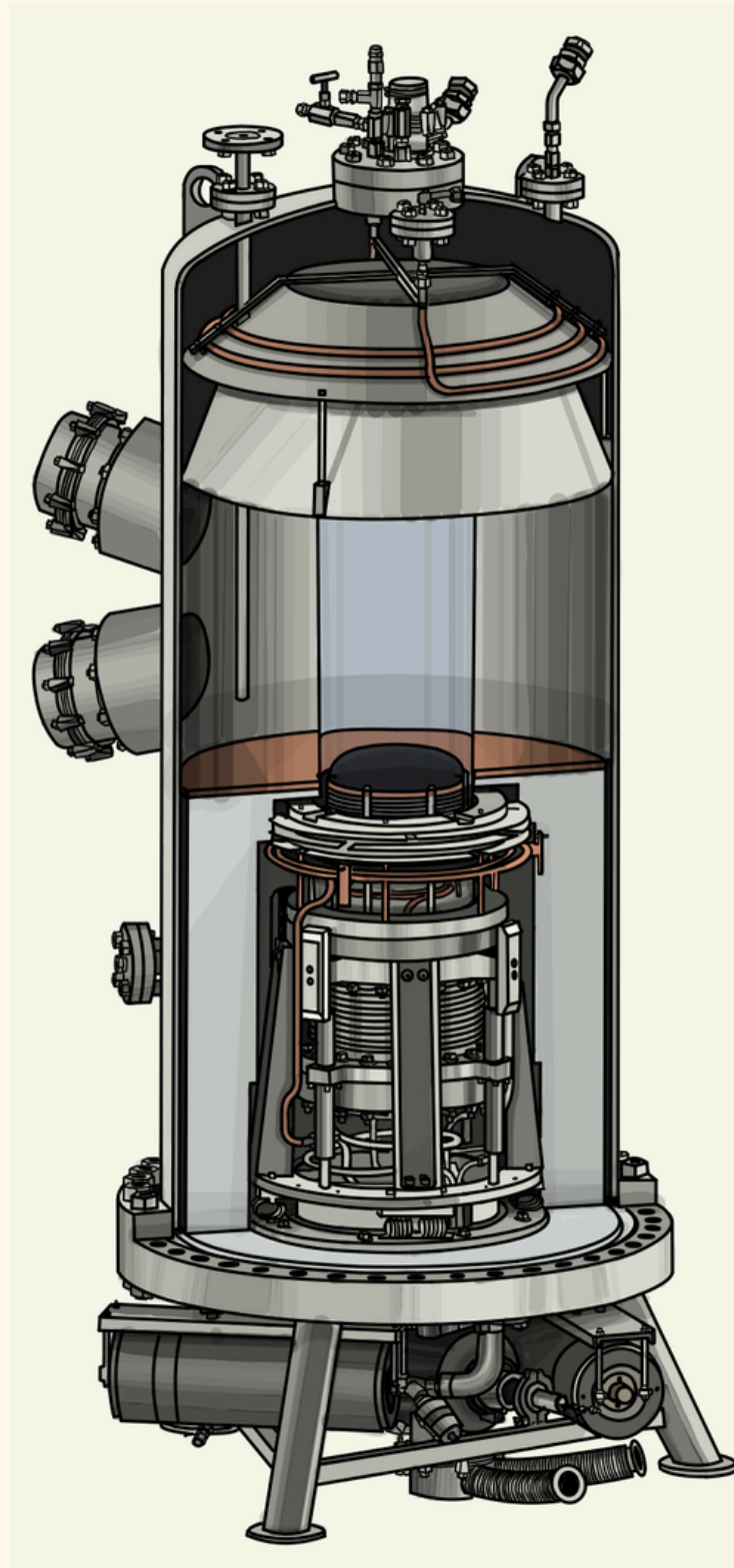

Credit: Lily Hines, MI/PICO

- Technology has been shown to be **stable**, can be **background free** and excellent nuclear recoil response.
- Freon fluids have **great spin-dependant interaction sensitivity in the WIMP region**.
- Fluids can be easily interchanged for probing different parameter space.
- C₃F₈, CF₃I, C₂H₂F₄ and Ar are **different possible targets with varying operating conditions**.

PICO-40L

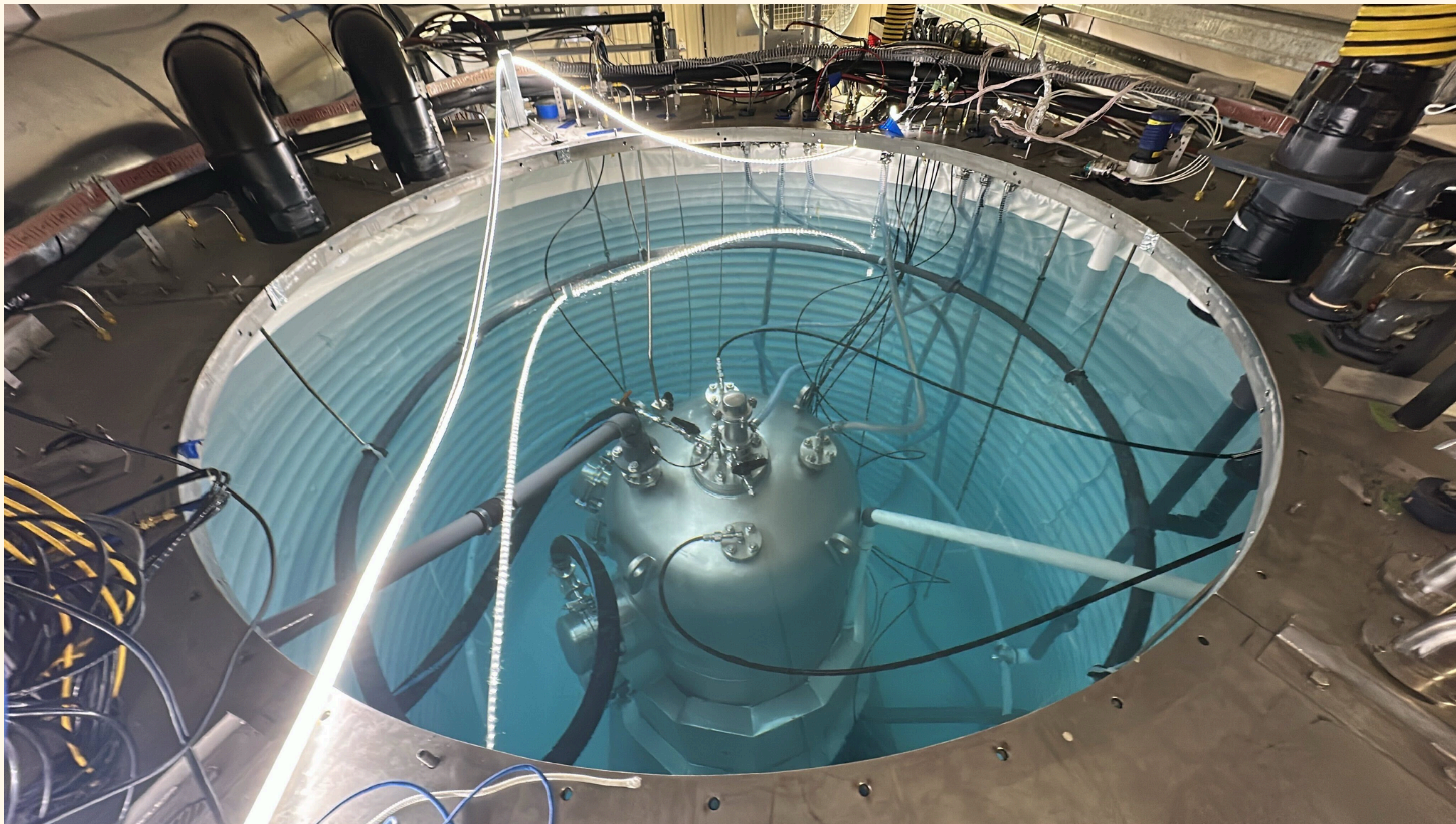

PICO-40L

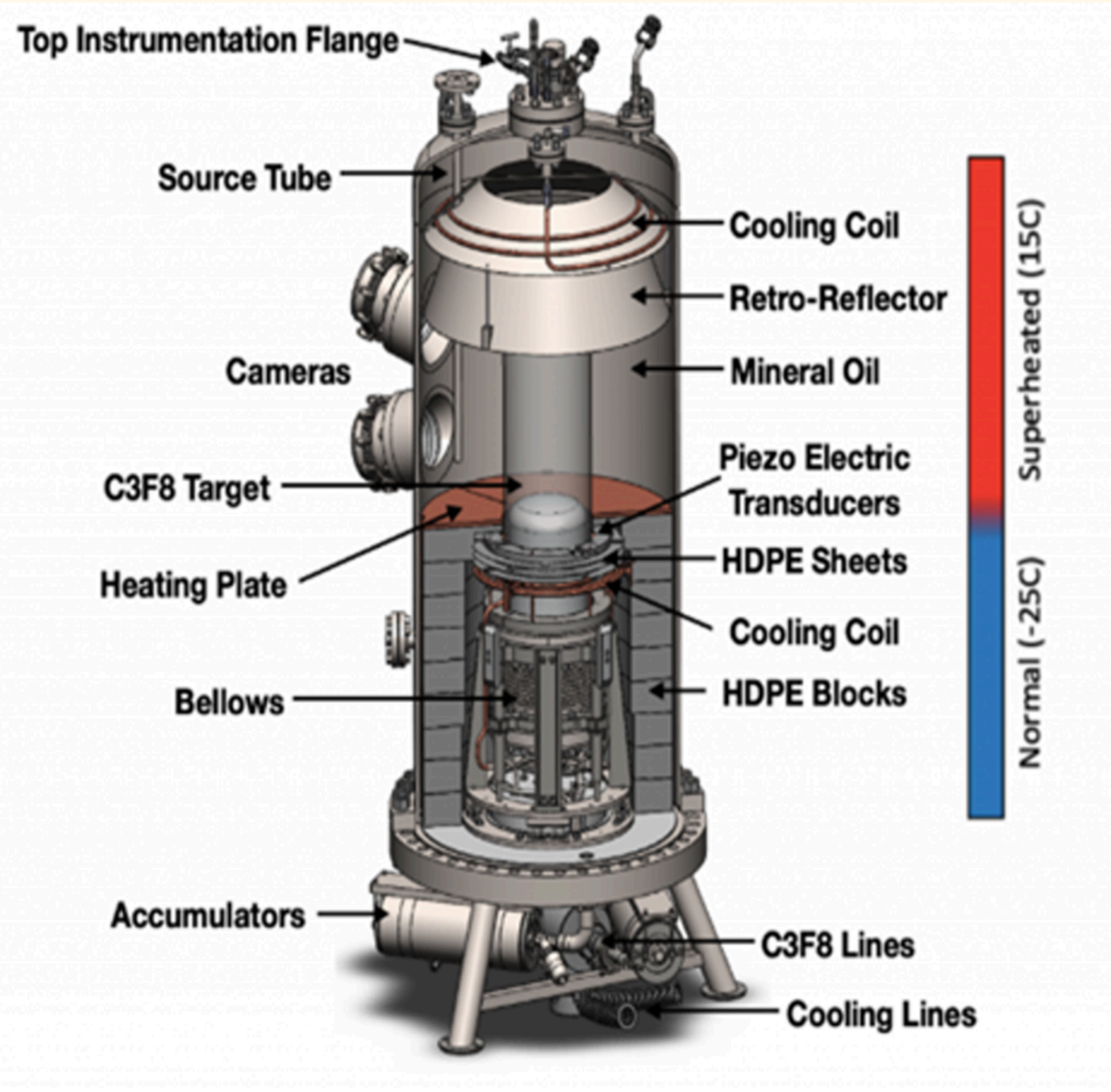

- Detector **located at SNOLAB**, has been running since 2023.
- Utilises **two quartz jars** connected by bellows to compress the target fluid, in a right-side up (RSU) design
- **Temperature gradient** is necessary to avoid unwanted events in the bellows.

Alpha Spectroscopy

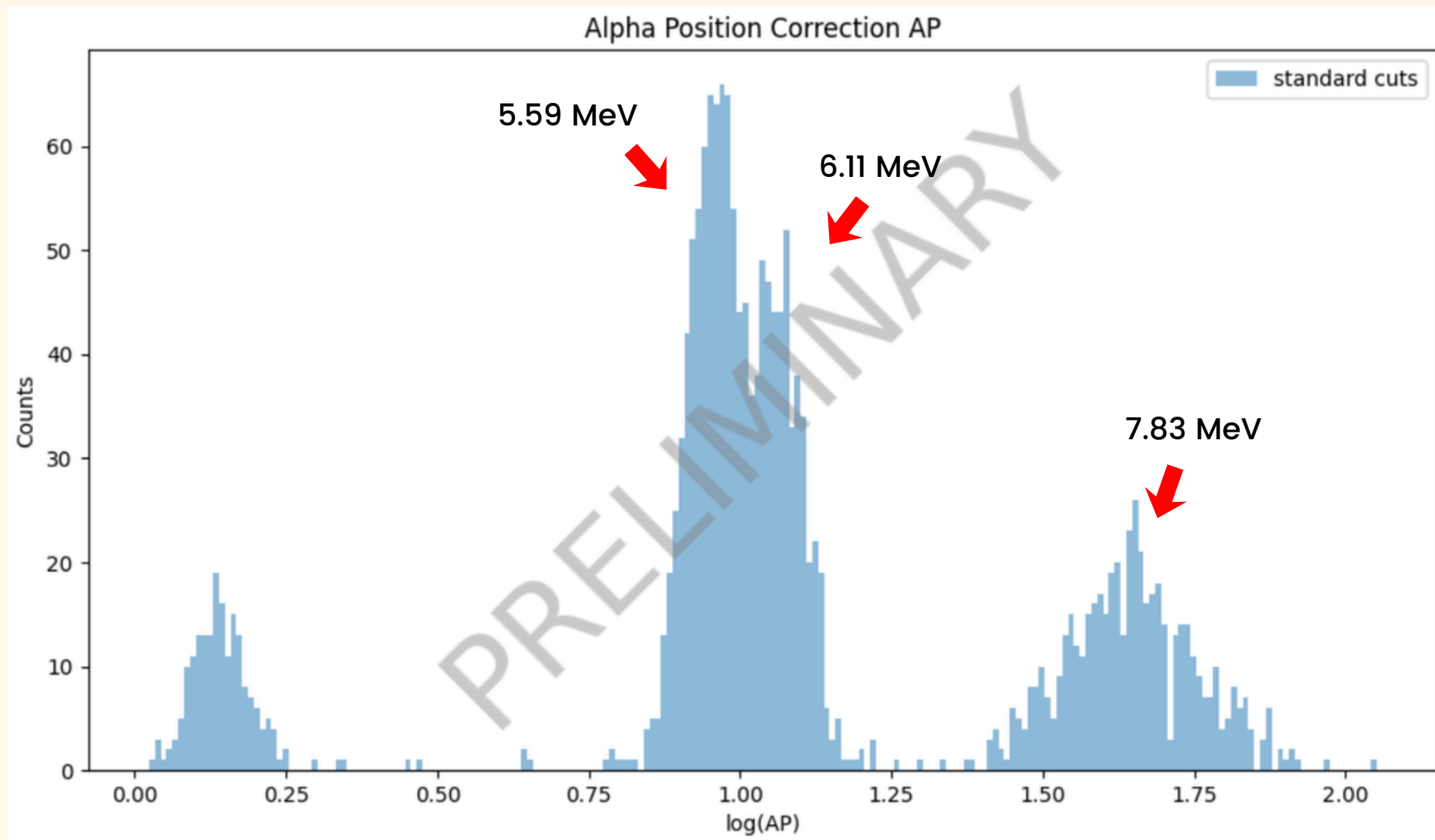

- We usually tune our AP with neutron calibration.
- By focusing our analysis of the acoustics on the alphas, we have been able to **resolve the alpha peaks**.
- This allows us to do **alpha spectroscopy**.
- Paper coming out at the end of the summer.

PICO-40L Projected limits

After approx. 1 year of livetime at 2.8 keV with 2 background events

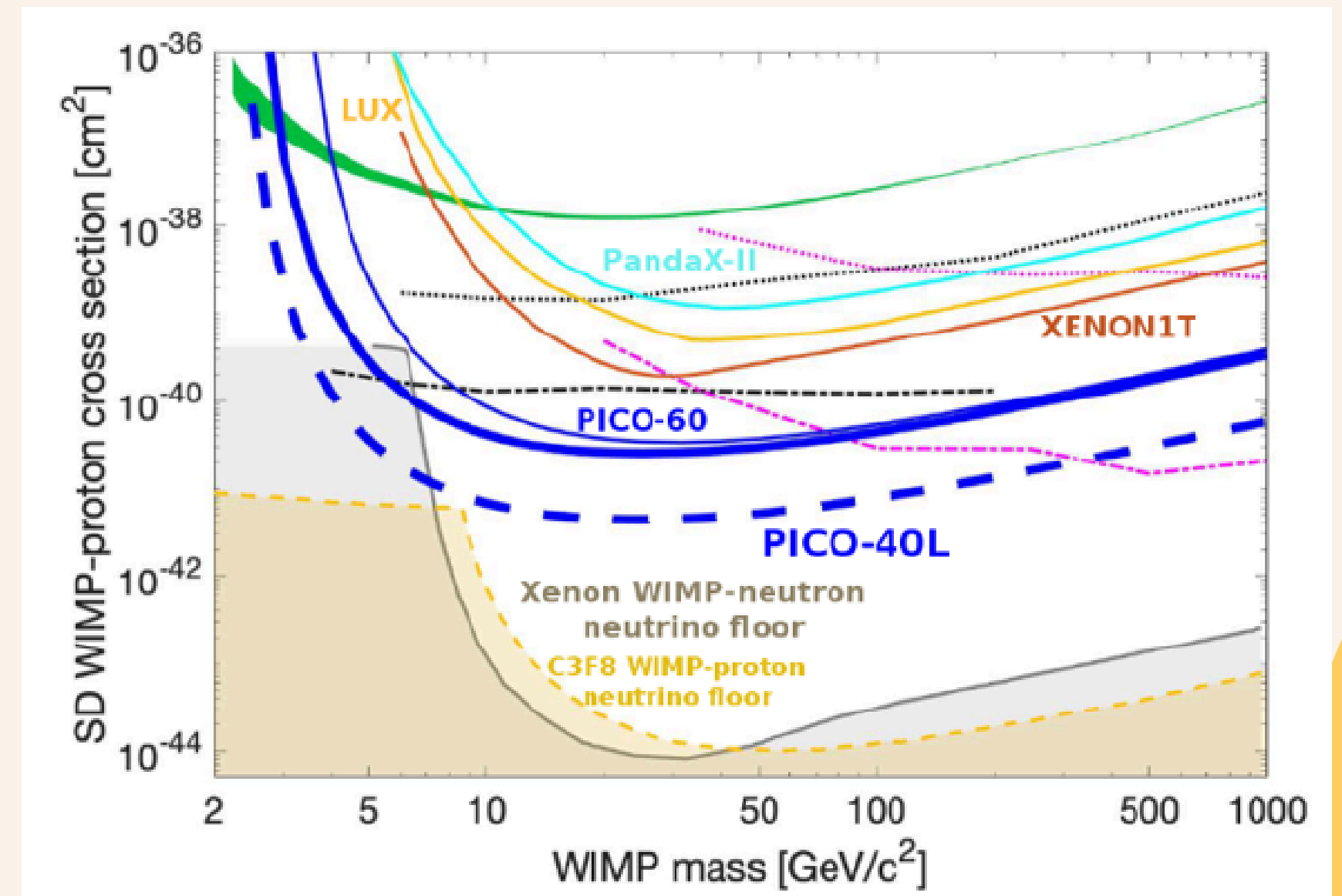
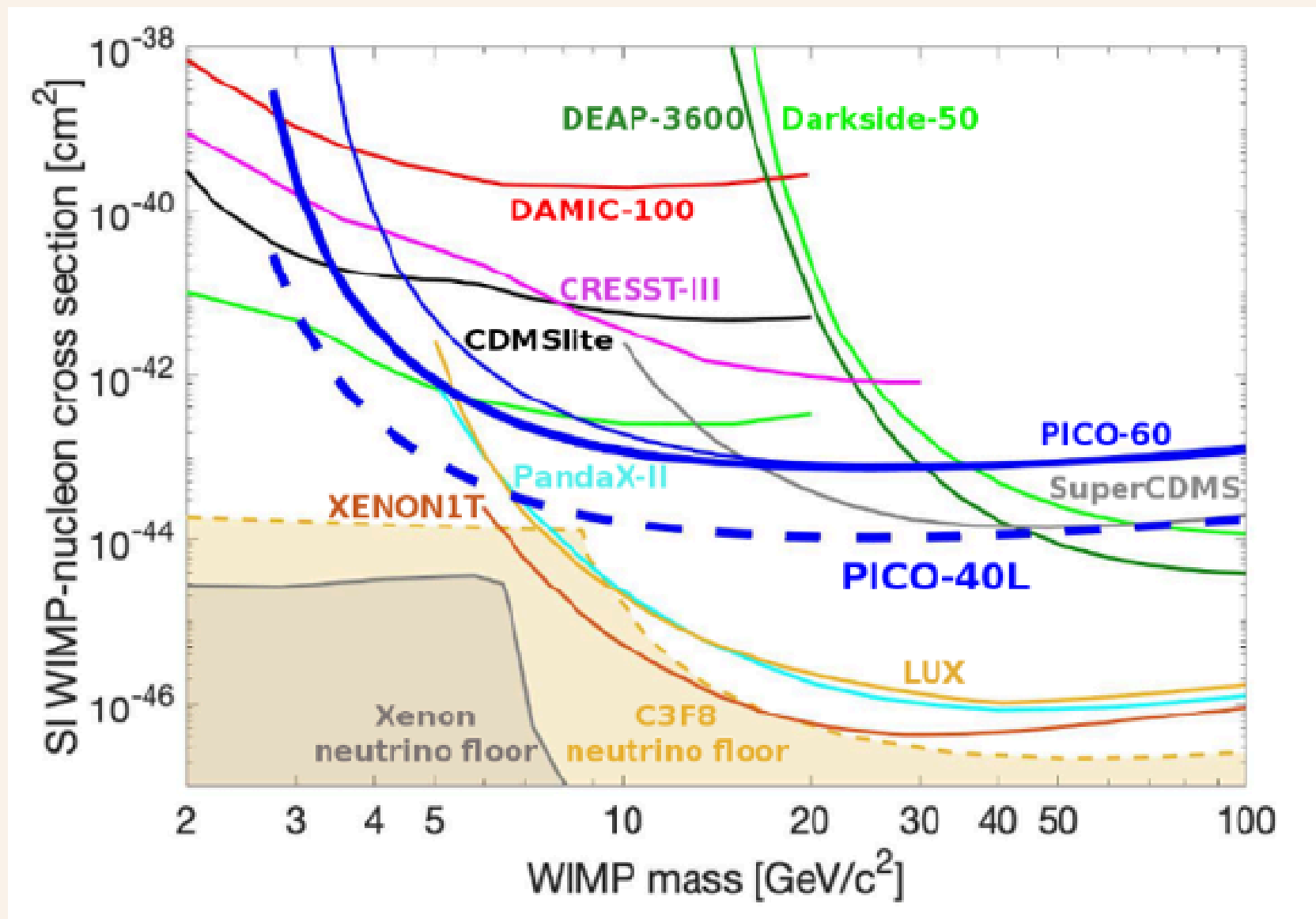

Lessons Learned from 40L

- Right-side up design works and **can be used effectively to run a dark matter experiments.**
- Temperature control is tricky, but ultimately do-able.
- Tackling **jar surface events** are key element in lowering the background rates.
- **Detector paper** coming out in about a month.

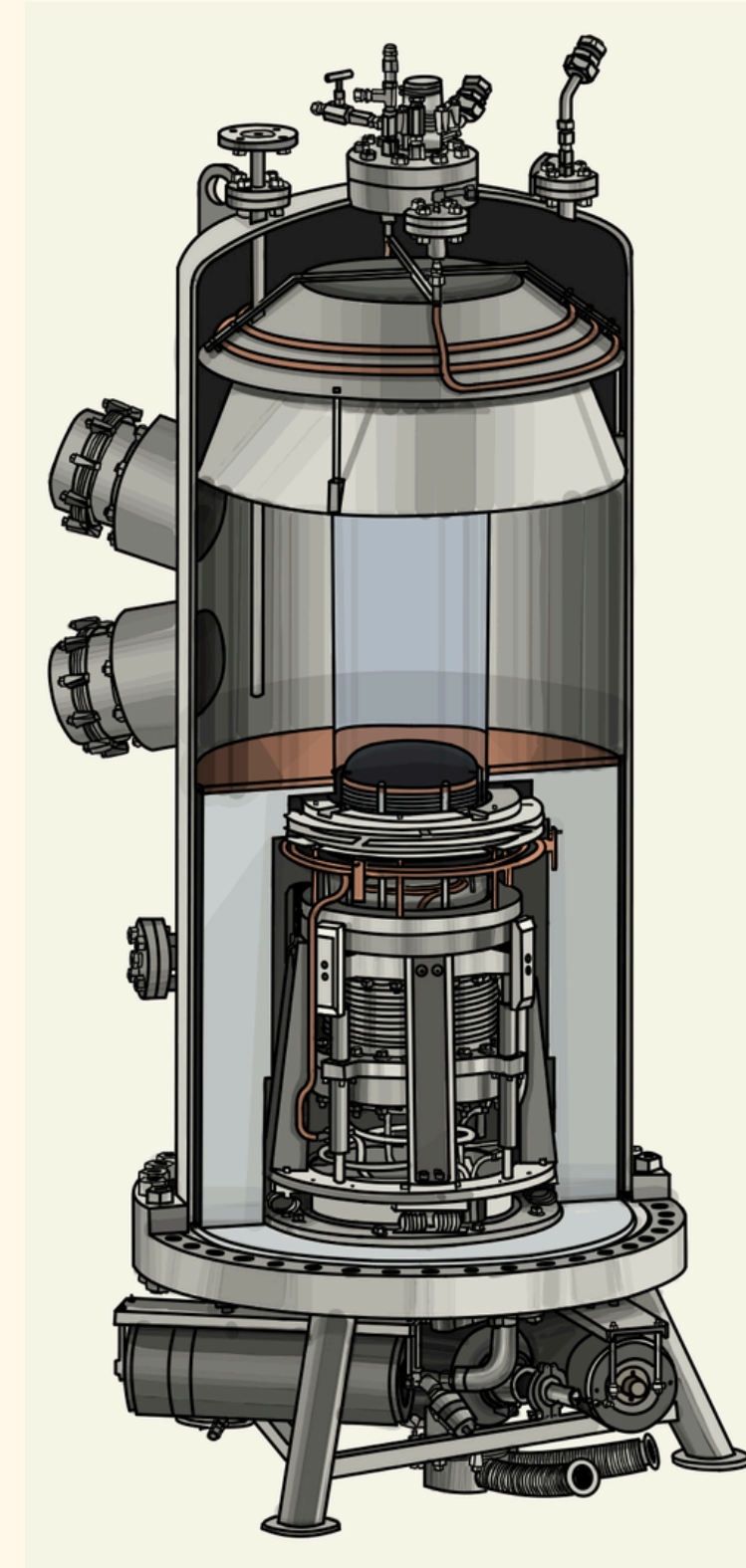

Credit: Lily Hines, MI/PICO

PICO-500

- Size of the detector means we have to **assemble it underground.**
- Many **low background techniques** were used.
- **Radon emanation assay analysis is currently underway** for background characterization.



Efficiency curves

Extras

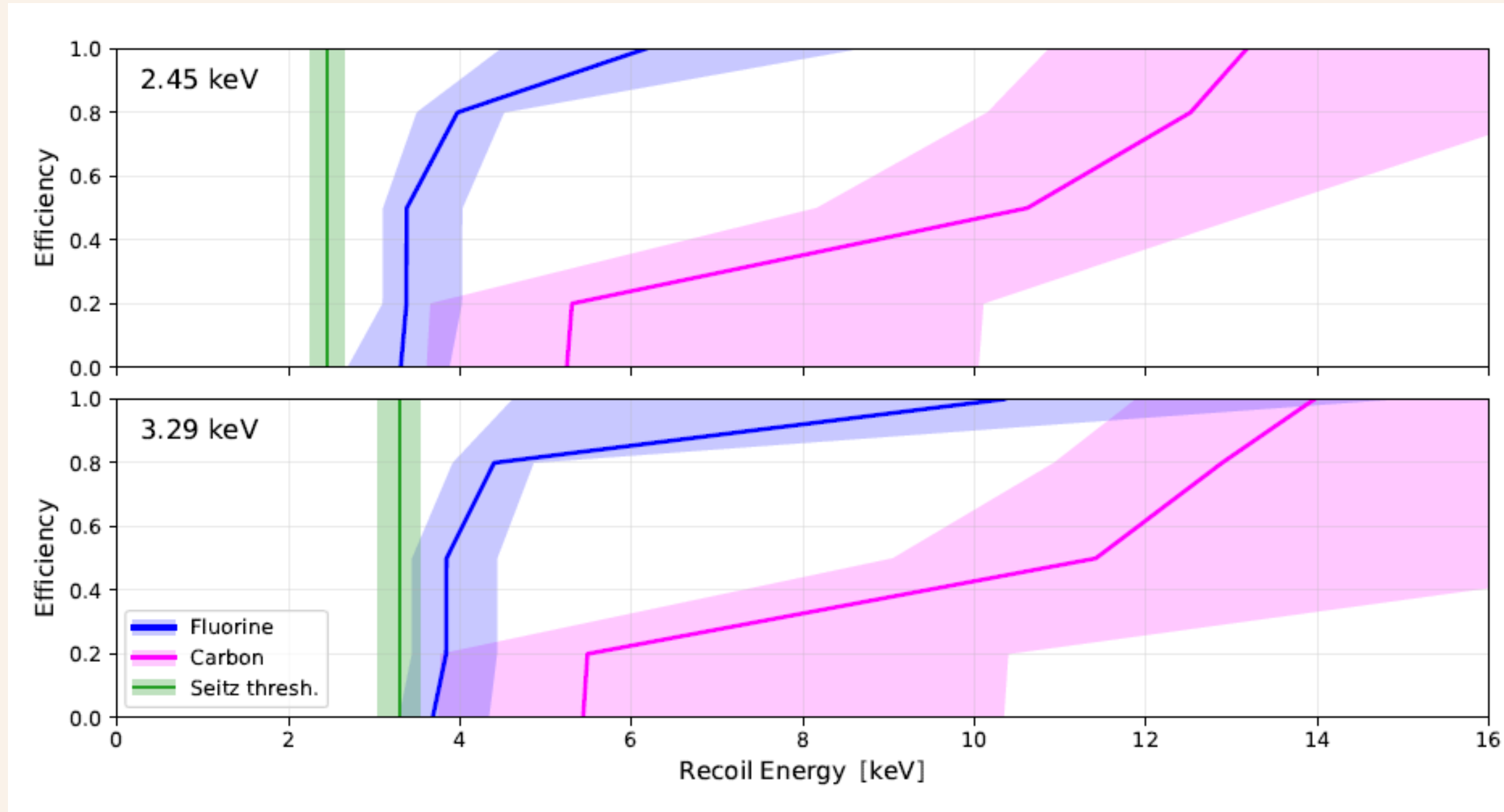

arXiv: 1902.04031

Bubble multiplicity

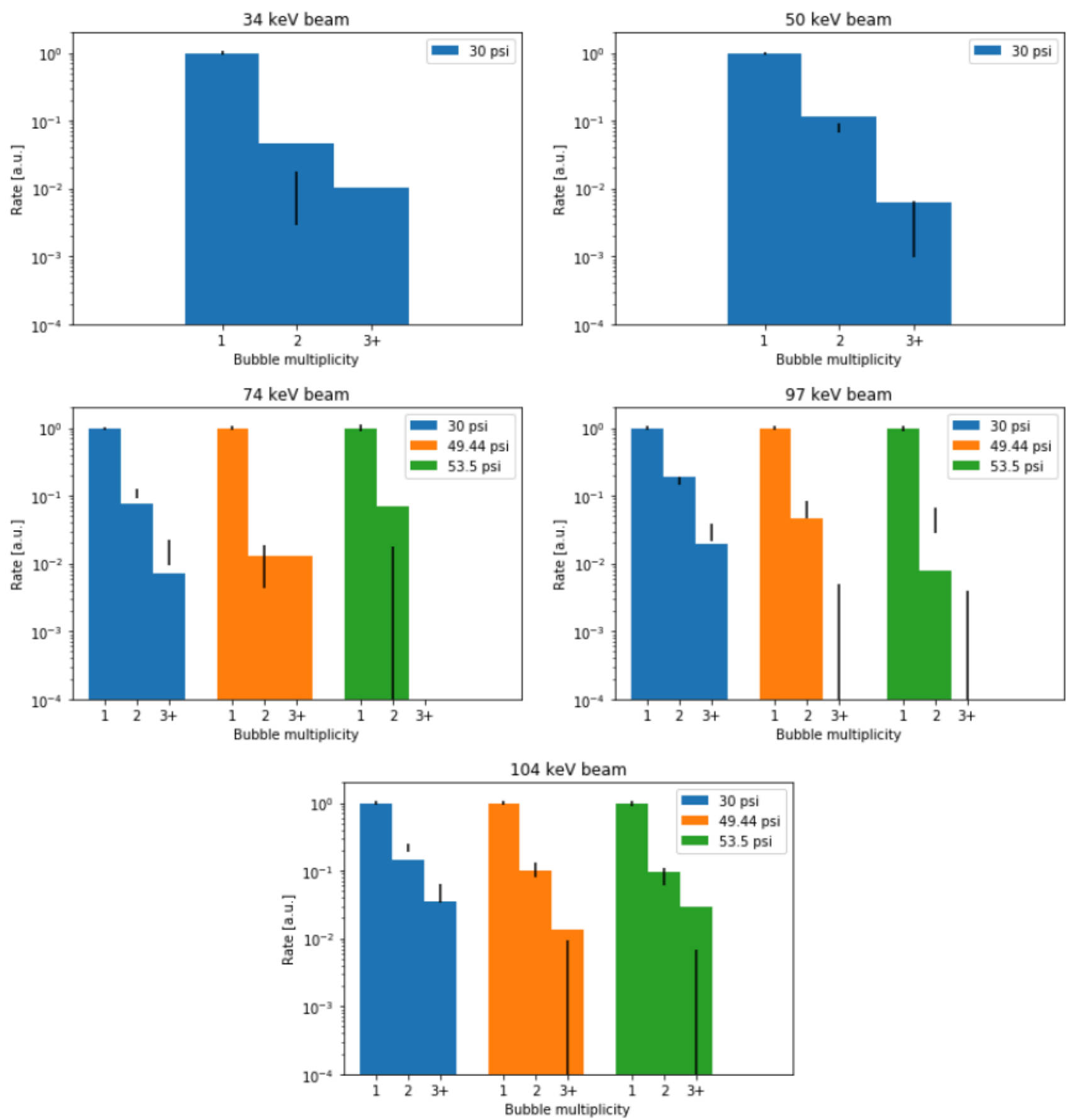

- **Single bubble neutron events are favored** over multiple bubble events.
- The higher the threshold, the lower the rate as a function of multiplicity.
- **Higher incident energy tends to have higher rates of multiplicity.**

Energy deposition

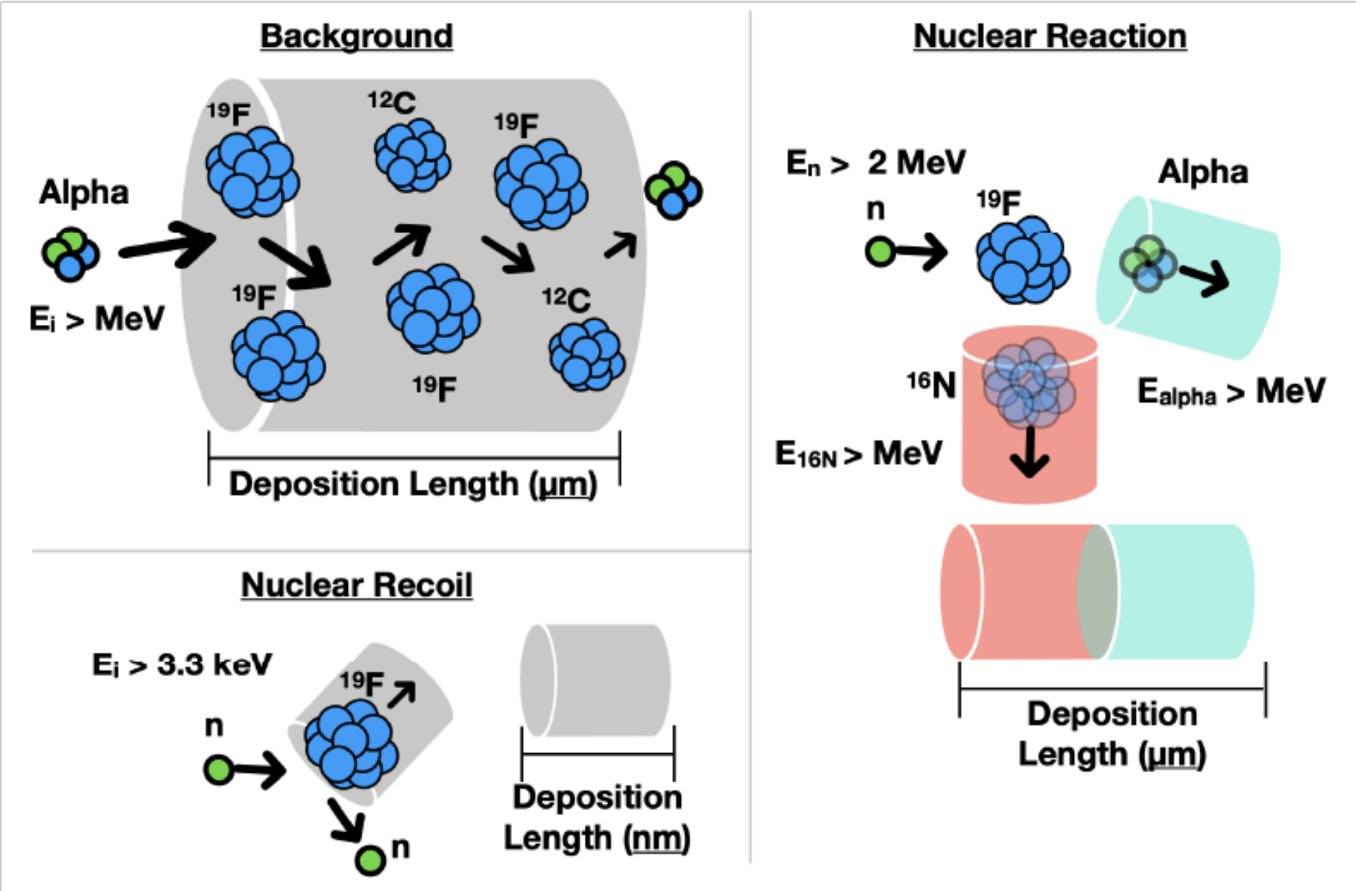

- Particles can deposit energy through different reactions which CAN produce a bubble.
- In **higher Z target**, we can also have **Auger cascade** from electron recoil.

Calculating the AP

Raw Signal

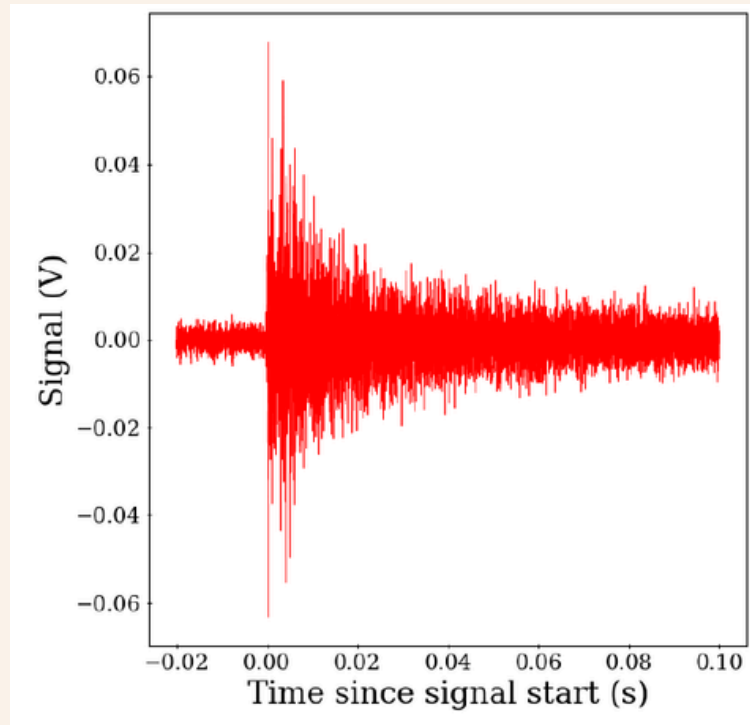

FFT

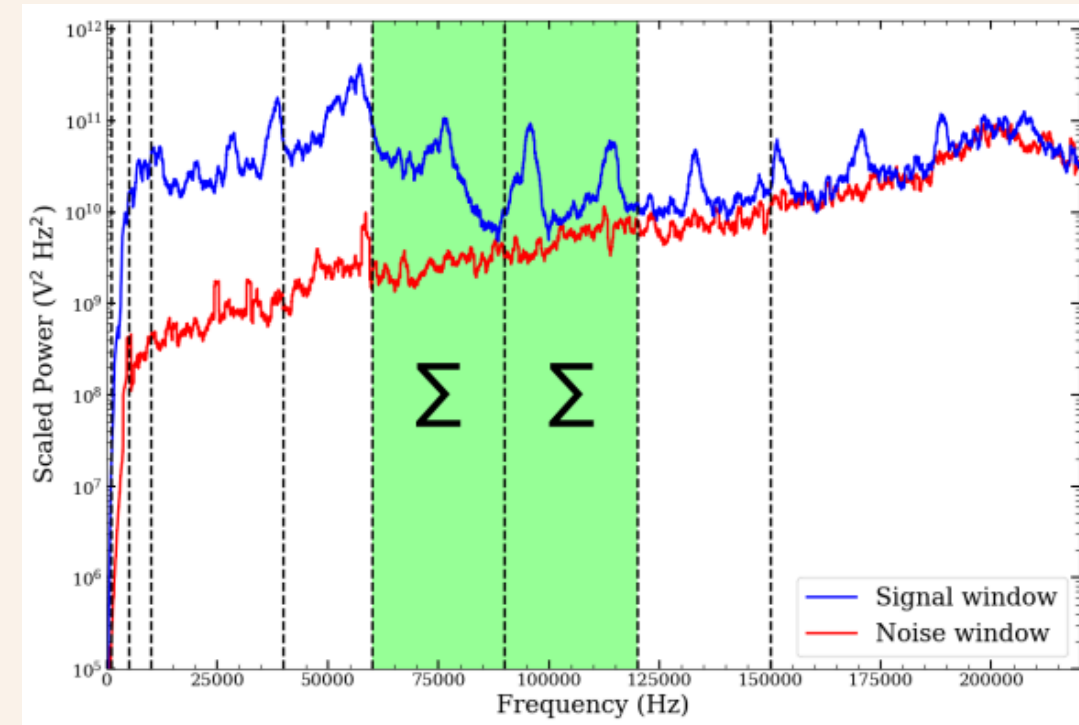
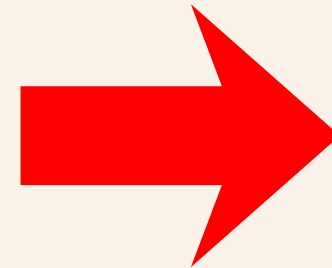

Coefficient fitted for position and double sum over all freq. bins and all piezos.

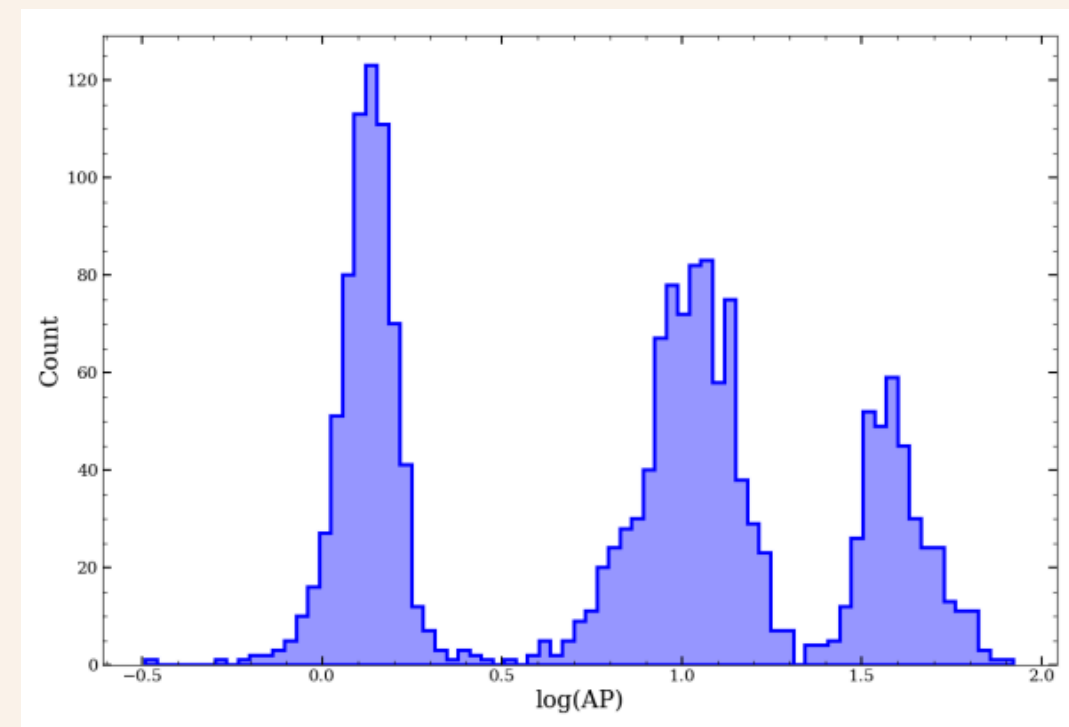
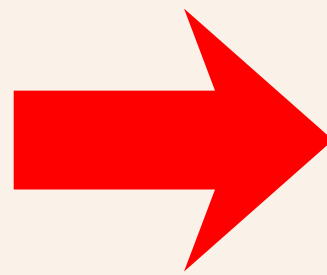

PICO-60

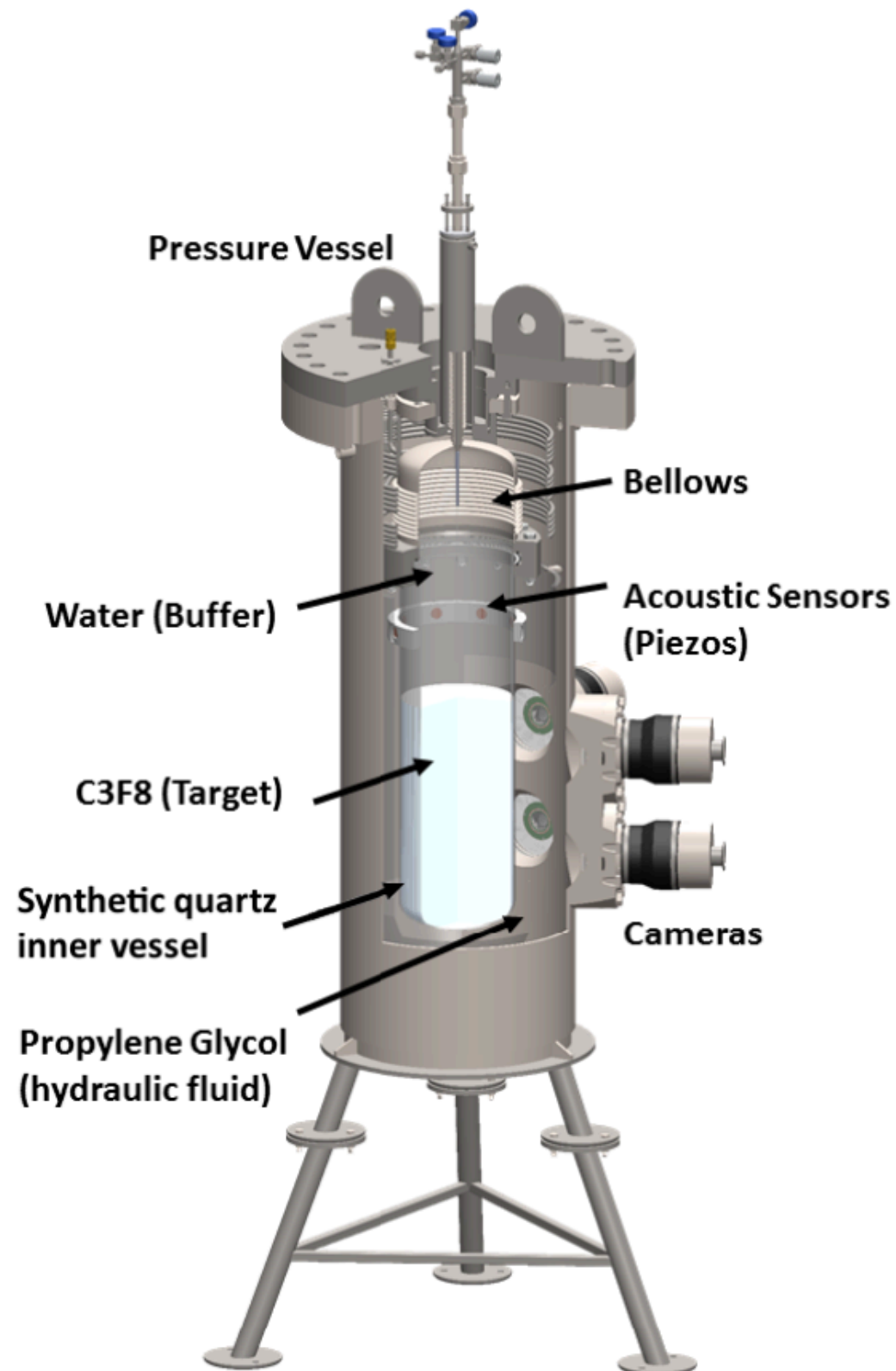

Full Exposure

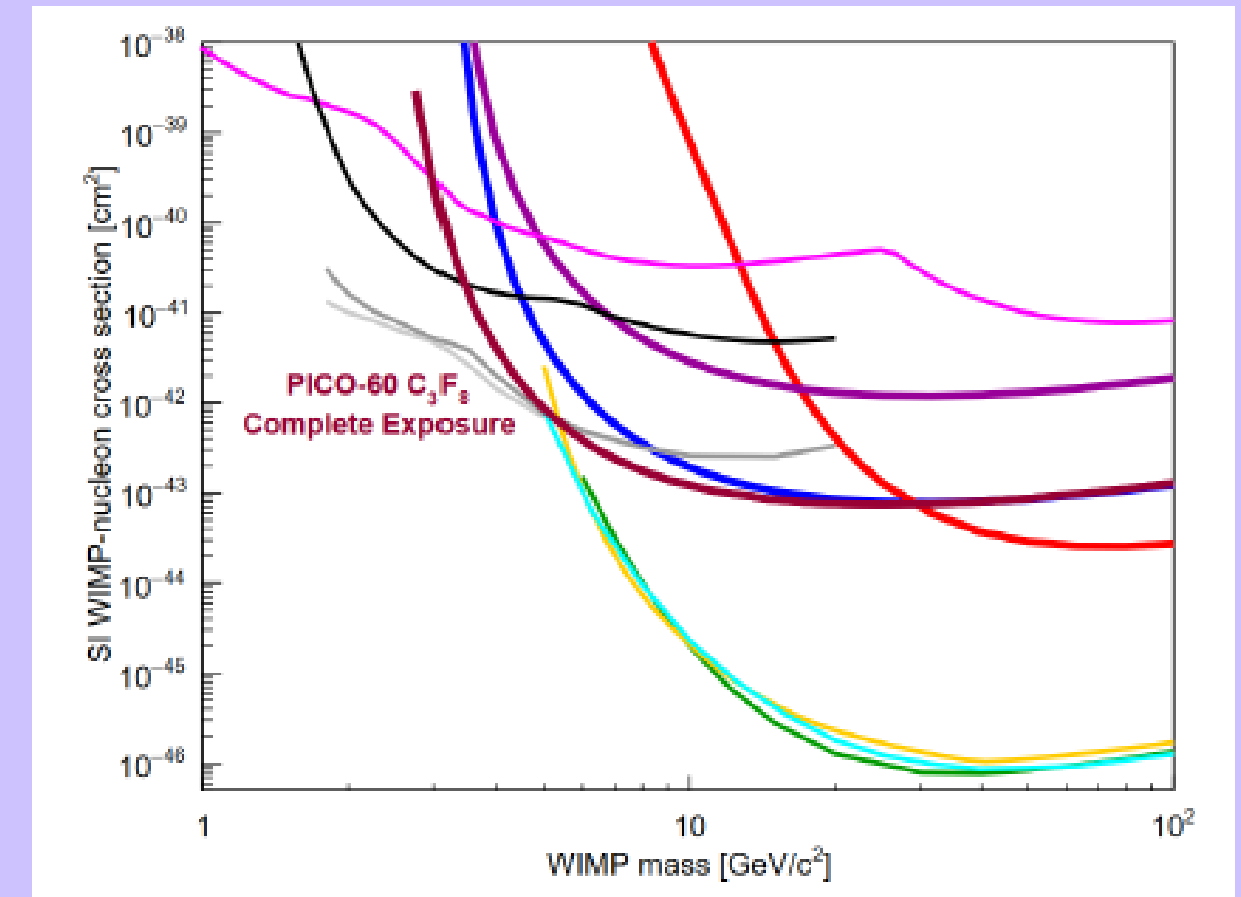
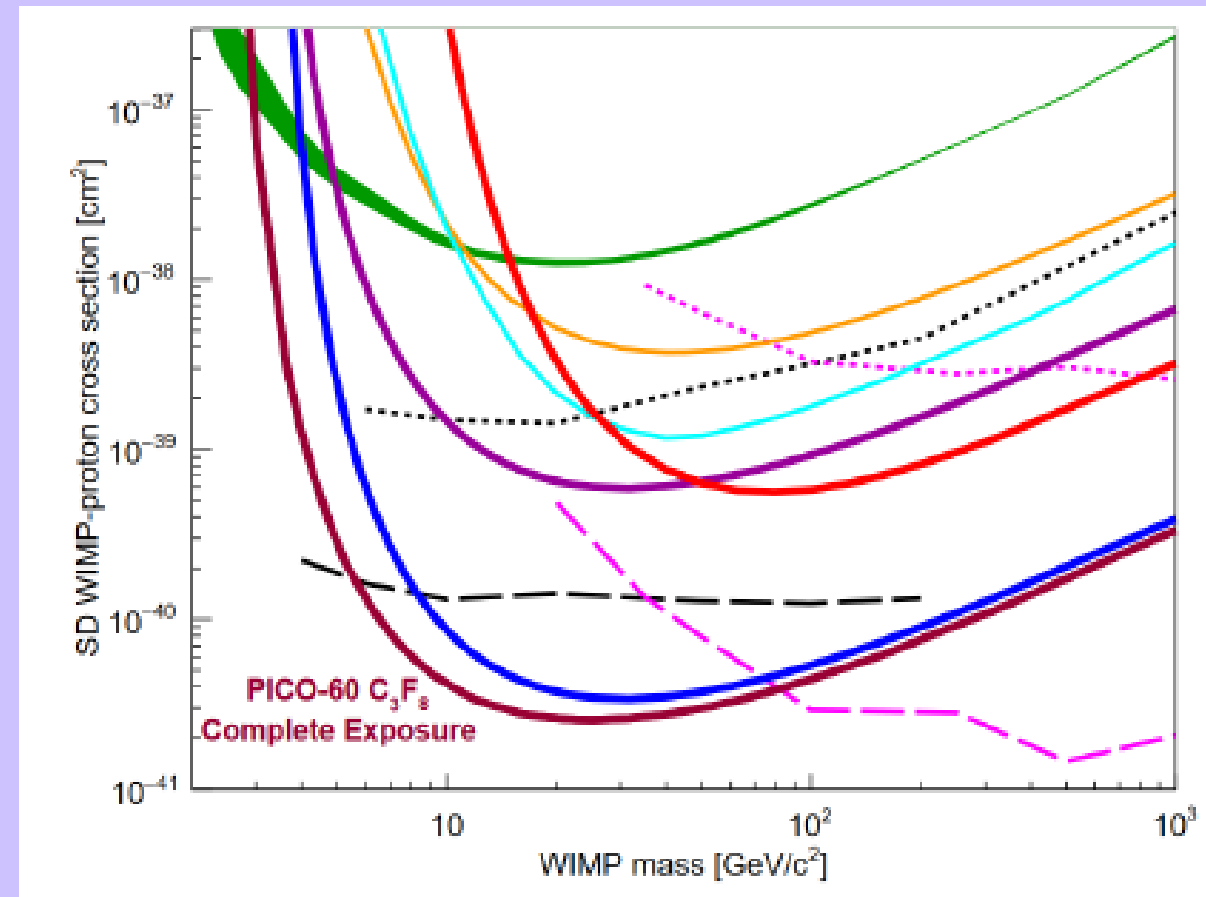

C. Amole et al. (PICO Collaboration) Phys. Rev. D 100, 022001 (2019)

World-leading in WIMP-proton in
2016-2017

PICO-60 Limitations

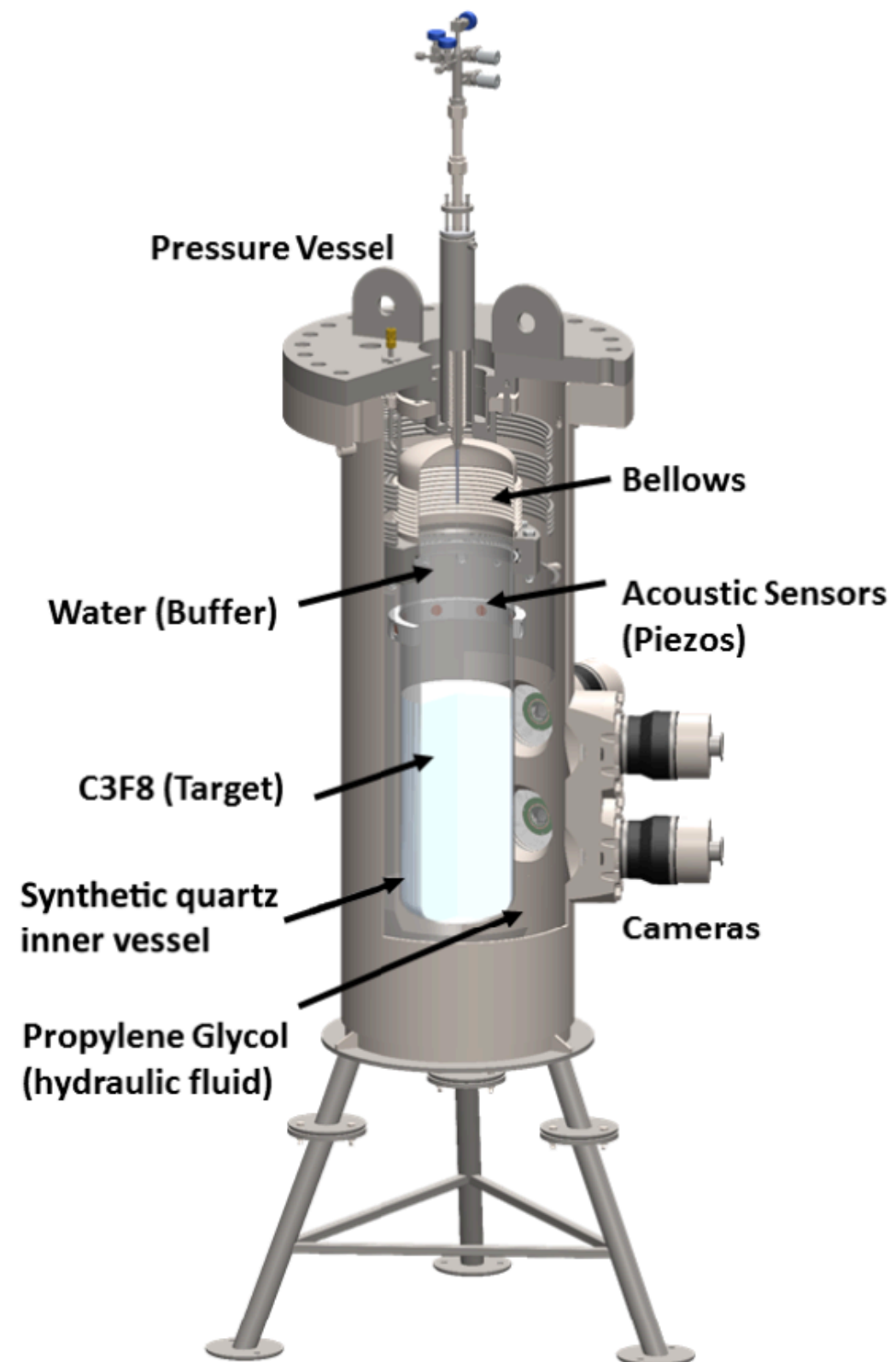

- Freon-water-jar interface has a higher rate
- Debris accumulation at the bottom of the jar

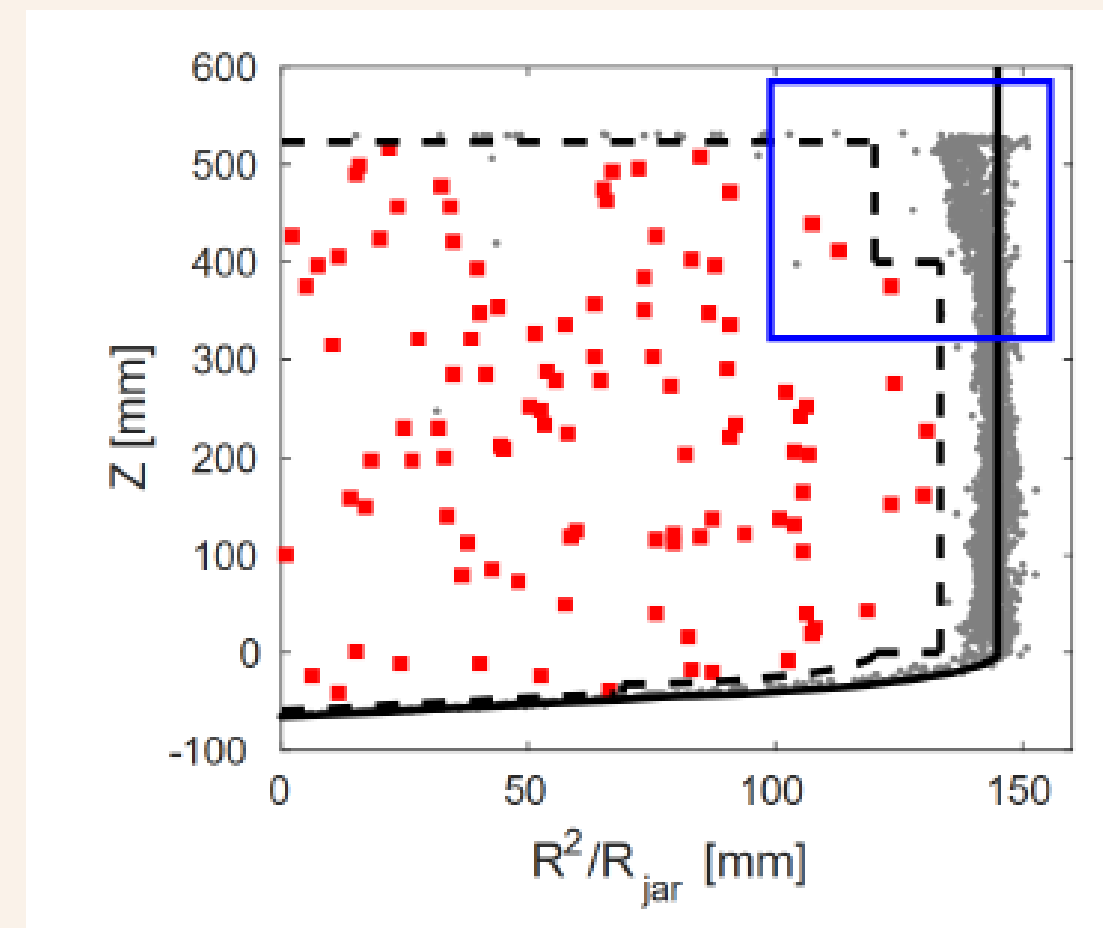

Why Bubble Chambers?

- Very low sensitivity to electron recoil
- Interchangeable fluid for different search
- Large parameter space left to explore

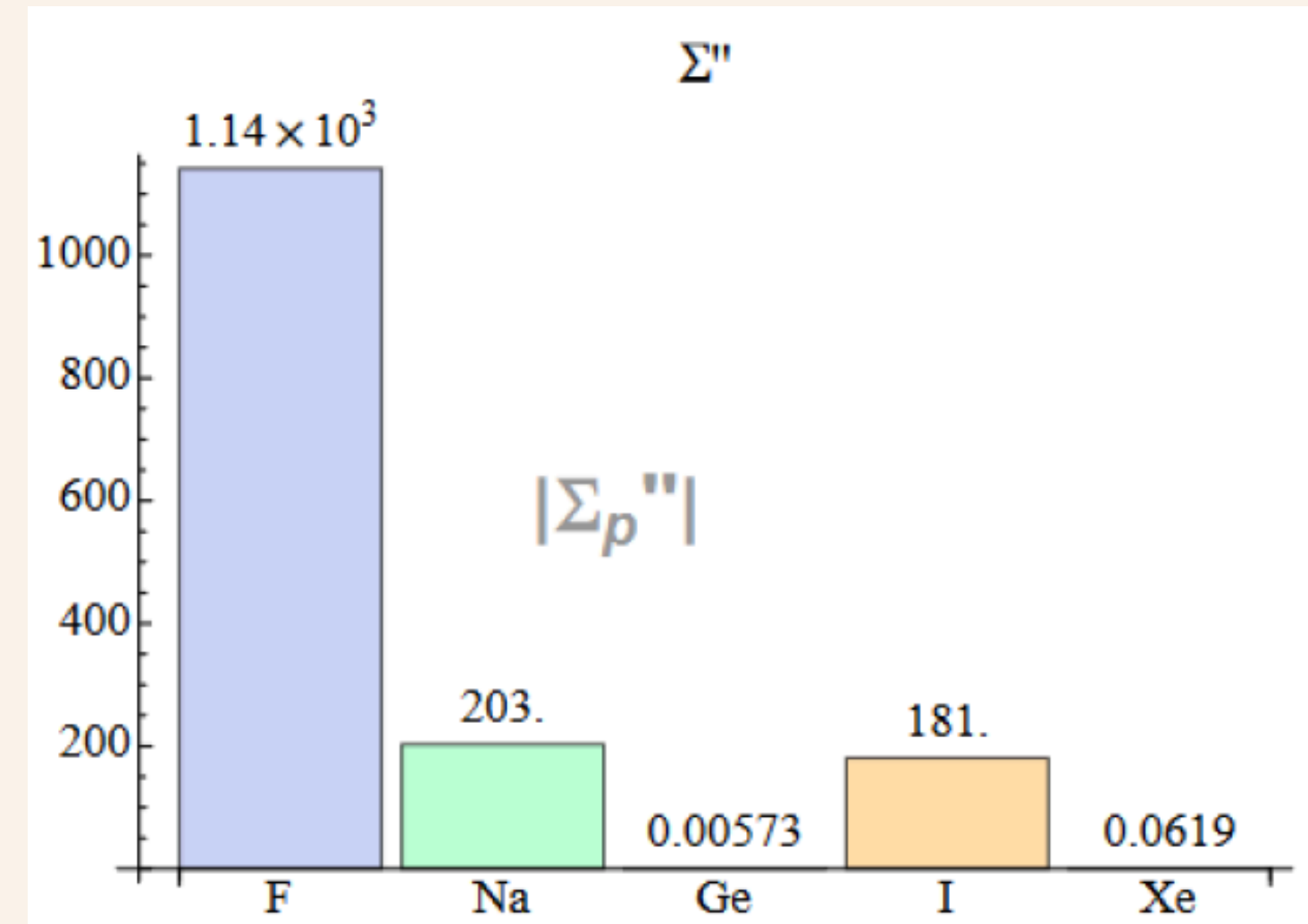
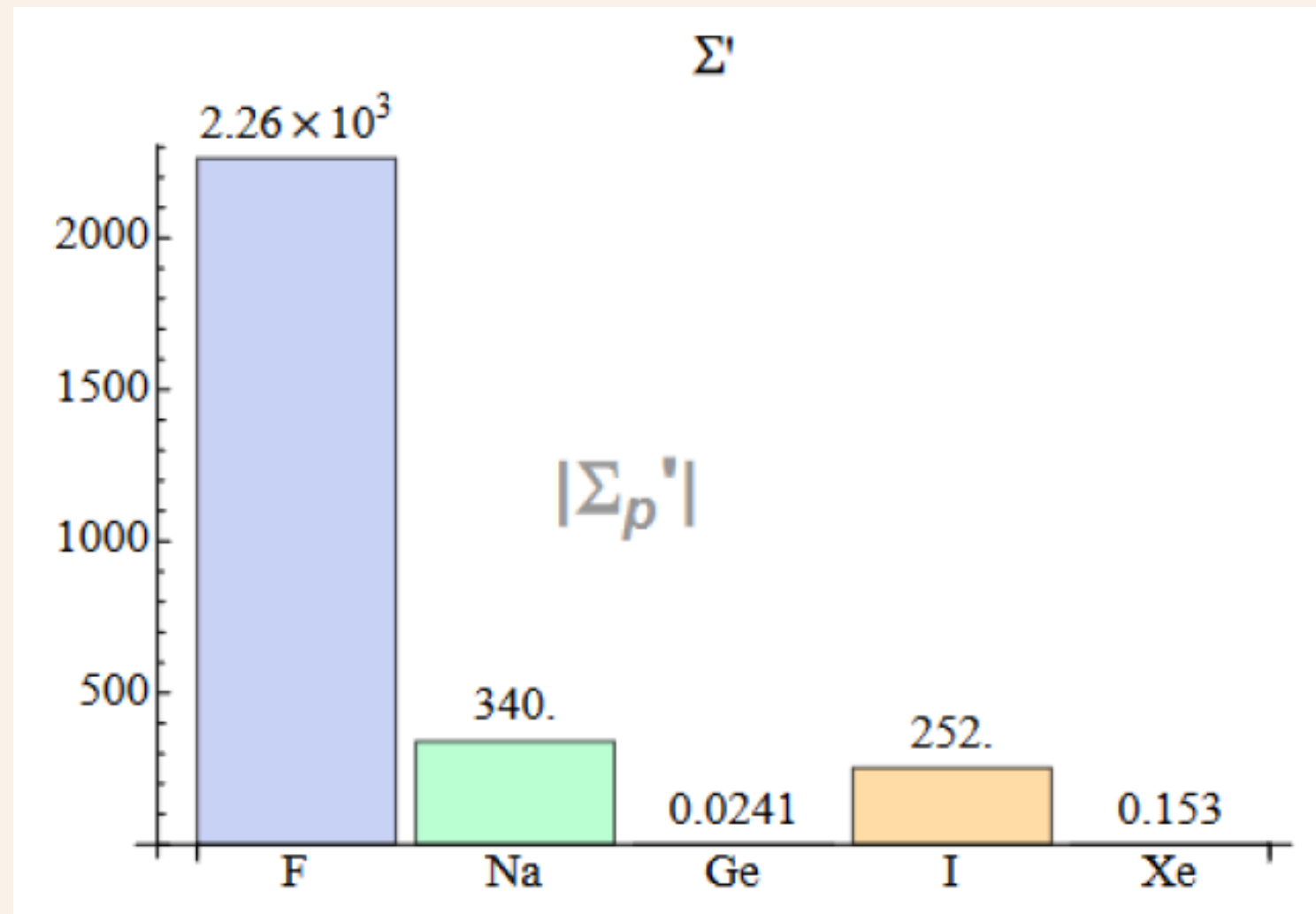

Why Bubble Chambers?

- Very low sensitivity to electron recoil
- Interchangeable fluid for different search
- Large parameter space left to explore

