



TUCAN

TRIUMF Ultracold
Advanced Neutron
Collaboration

Development and testing of the TUCAN superfluid He-II based ultra cold neutron source at TRIUMF

Wolfgang Klassen

On behalf of the TUCAN collaboration

June 25, 2026

CAP Congress

Ottawa, Ontario, Canada



TUCAN

TRIUMF Ultracold
Advanced Neutron
Collaboration

World's Most Intense UCN Source

Wolfgang Klassen

On behalf of the TUCAN collaboration

June 25, 2026

CAP Congress

Ottawa, Ontario, Canada

The TUCAN collaboration



TUCAN

TRIUMF Ultracold
Advanced Neutron
Collaboration

- More than a dozen member institutes
- More than a dozen graduate students at any time
- 50+ active collaborators
- Strong international cooperation

Note: some markers are indicating more than one institution

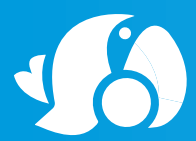

What are UCN?



- UltraCold Neutrons
- Neutrons with kinetic energy < 300 neV
- Velocity of ~ 5 m/s

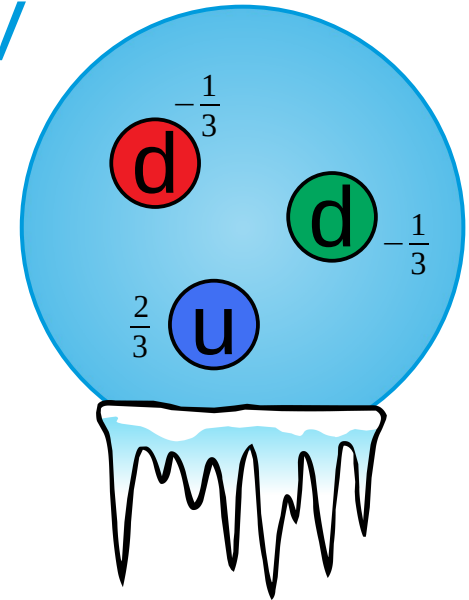

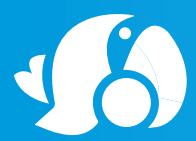

Whats interesting about UCN?



- They interact significantly with all 4 fundamental forces:

Gravity

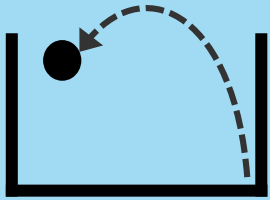

$$V_g = 102.5 \frac{\text{neV}}{\text{m}}$$

Electromagnetism

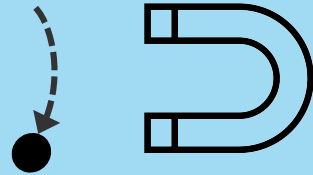

$$\mu_N = 60.3 \frac{\text{neV}}{\text{T}}$$

Strong nuclear

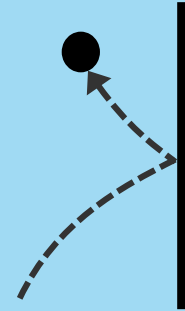

$$V_{\text{Fermi}} < 300 \text{ neV}$$

Weak nuclear

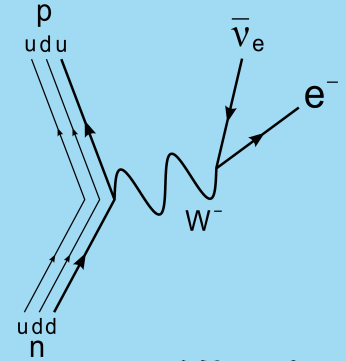

$$\tau_n \approx 15 \text{ min}$$

kinetic energy $< 300 \text{ neV}$

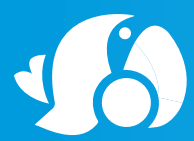

Whats interesting about UCN?



Gravity

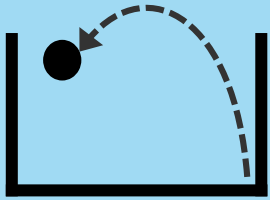

$$V_g = 102.5 \frac{\text{neV}}{\text{m}}$$

- Quantized gravity
- Short range tests of gravity

Electromagnetism

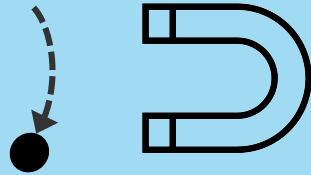

$$\mu_N = 60.3 \frac{\text{neV}}{\text{T}}$$

- nEDM search
- Precision magnetic moment measurements

Strong nuclear

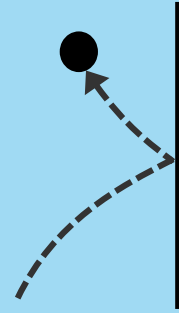

$$V_{\text{Fermi}} < 300 \text{ neV}$$

- UCN optics
- Short range tests of the strong force

Weak nuclear

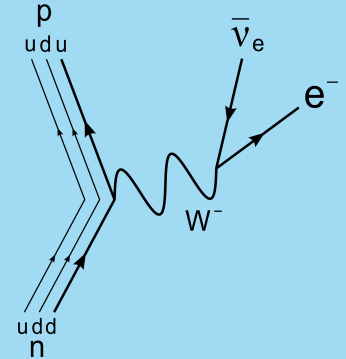

$$\tau_n \approx 15 \text{ min}$$

- Lifetime puzzle
- β -decay correlation
- Sterile neutrinos/dark decay channels

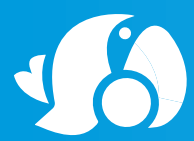

Whats interesting about UCN?



Gravity

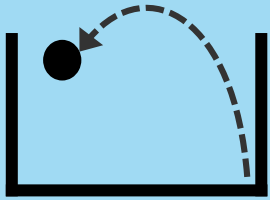

$$V_g = 102.5 \frac{\text{neV}}{\text{m}}$$

- Quantized gravity
- Short range tests of gravity

Electromagnetism

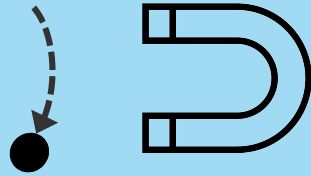

$$\mu_N = 60.3 \frac{\text{neV}}{\text{T}}$$

- **nEDM search**
- Precision magnetic moment measurements

Strong nuclear

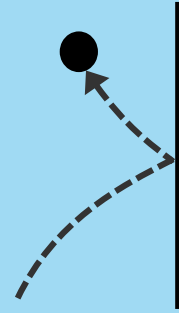

$$V_{\text{Fermi}} < 300 \text{ neV}$$

- UCN optics
- Short range tests of the strong force

Weak nuclear

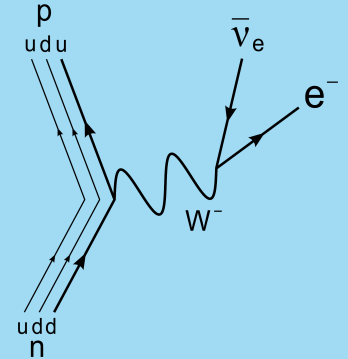

$$\tau_n \approx 15 \text{ min}$$

- Lifetime puzzle
- β -decay correlation
- Sterile neutrinos/dark decay channels

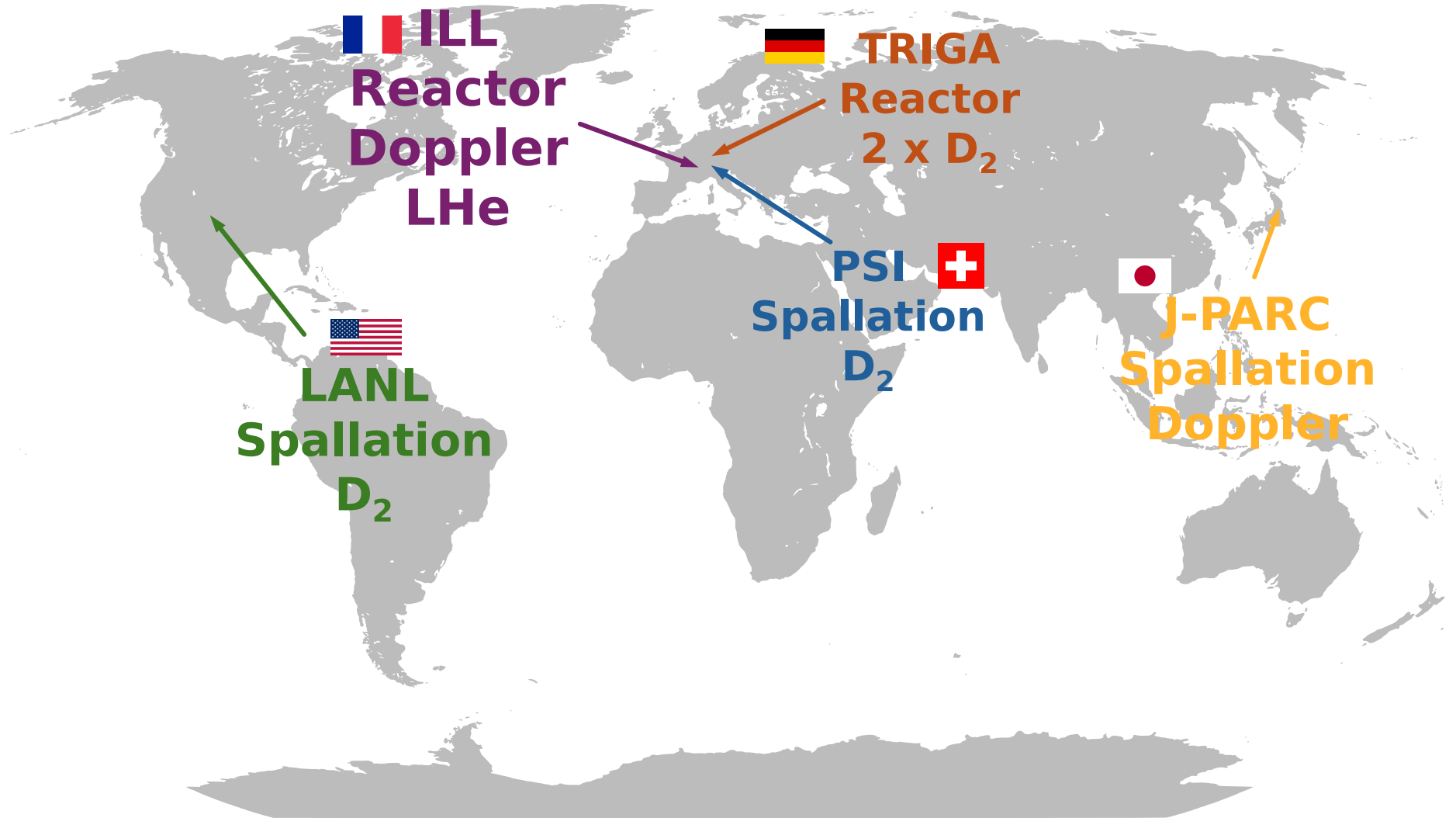

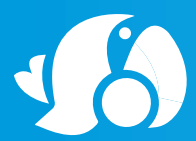

Making UCN



- Need lots of neutrons!

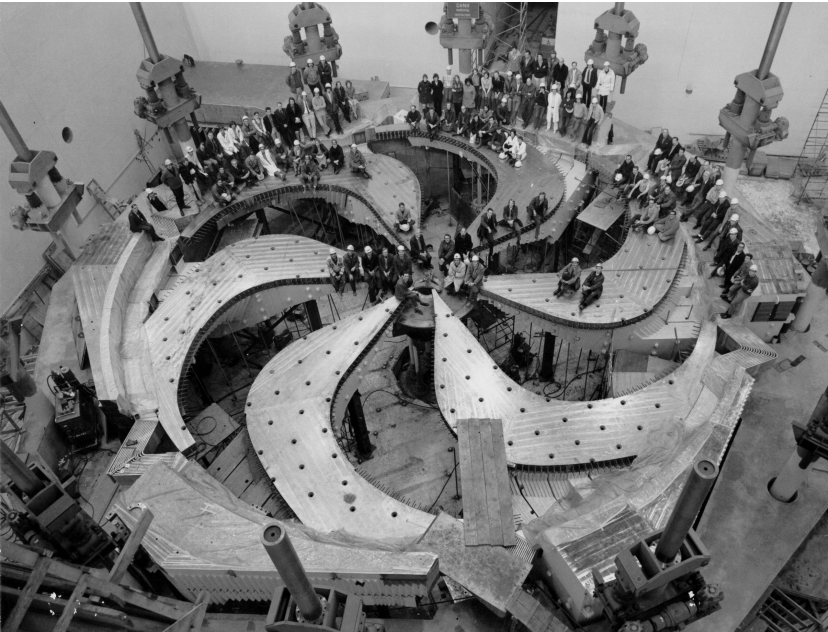

The TRIUMF main cyclotron

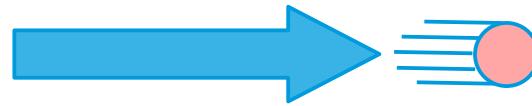

483 MeV proton beam

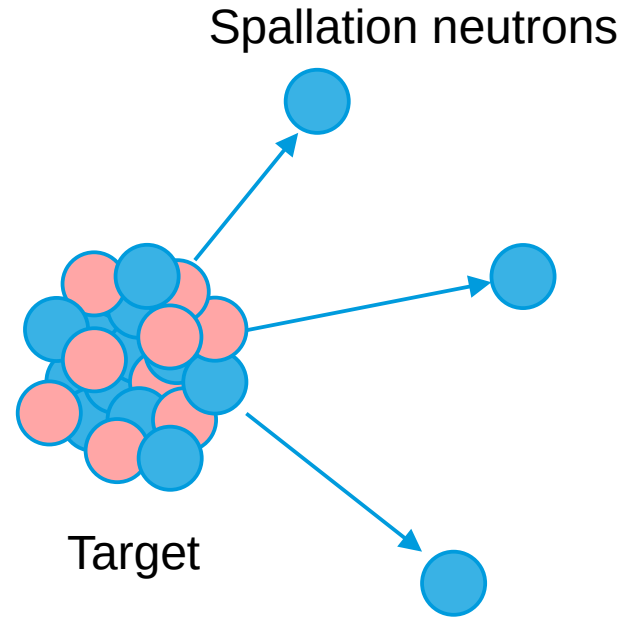

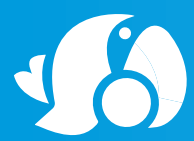

Making UCN

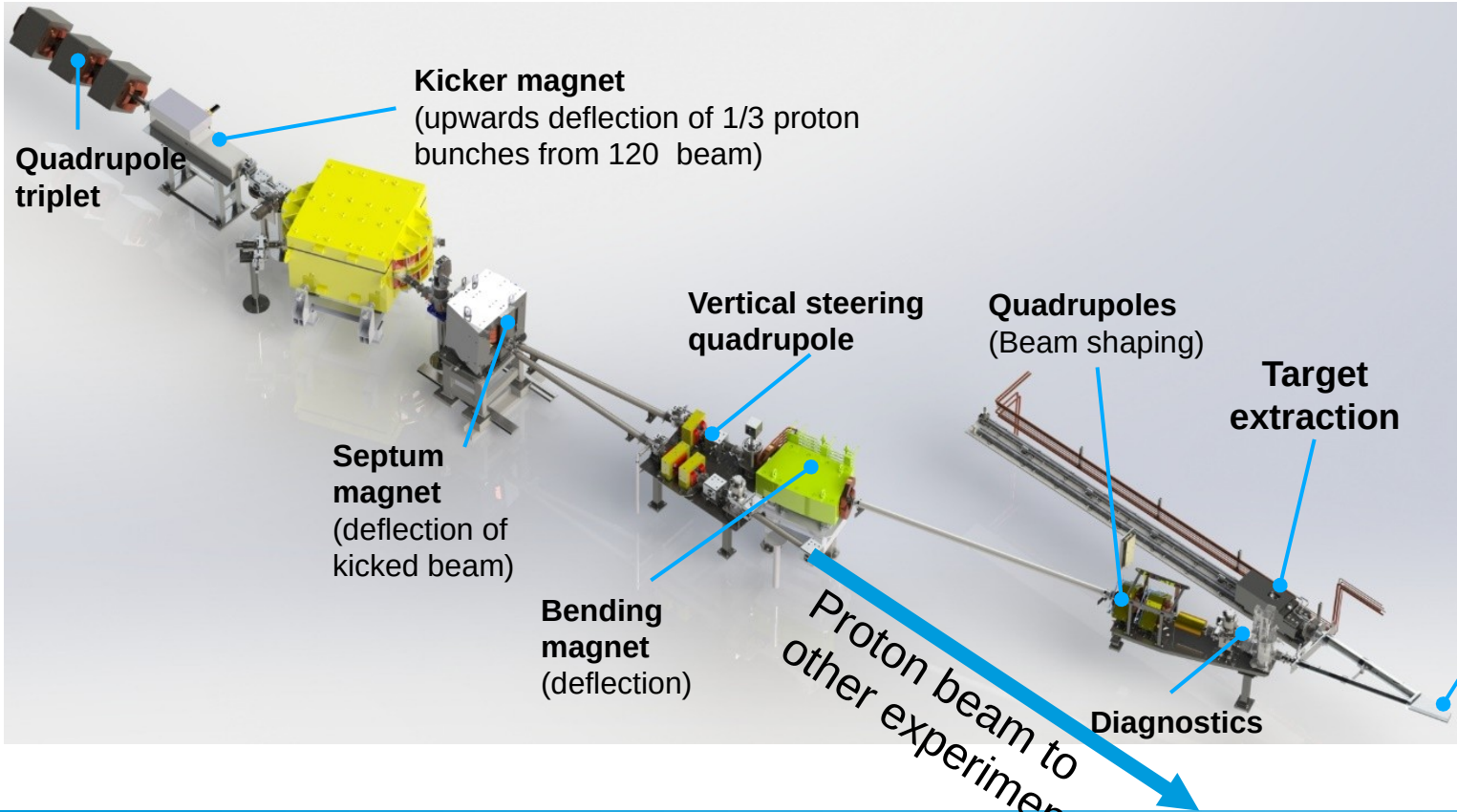

Tantalum-clad tungsten target

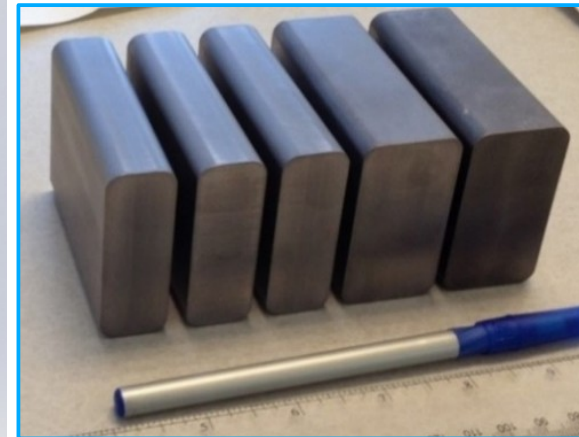

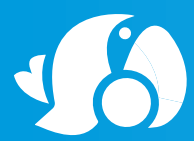

Making UCN



- Spallation neutrons are hot!
 - Need to get rid of a lot of energy
 - Two ways:

Thermal

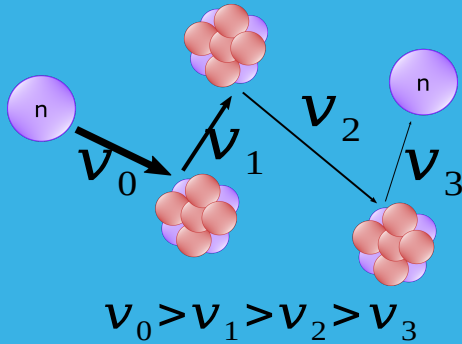

Superthermal

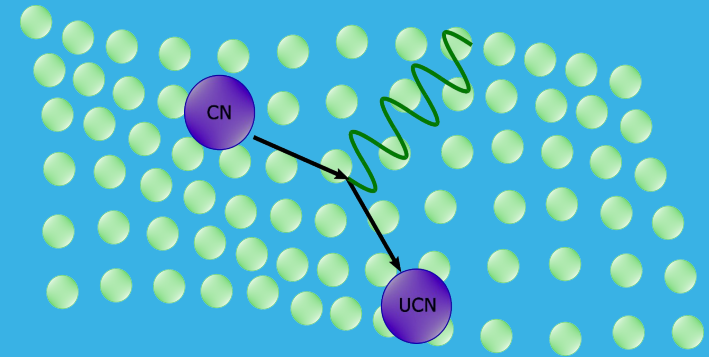

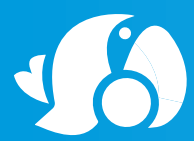

Moderation

- Spallation neutrons thermally equilibrate in room-temperature heavy water
- Become “thermal neutrons”
- 430 L of heavy water

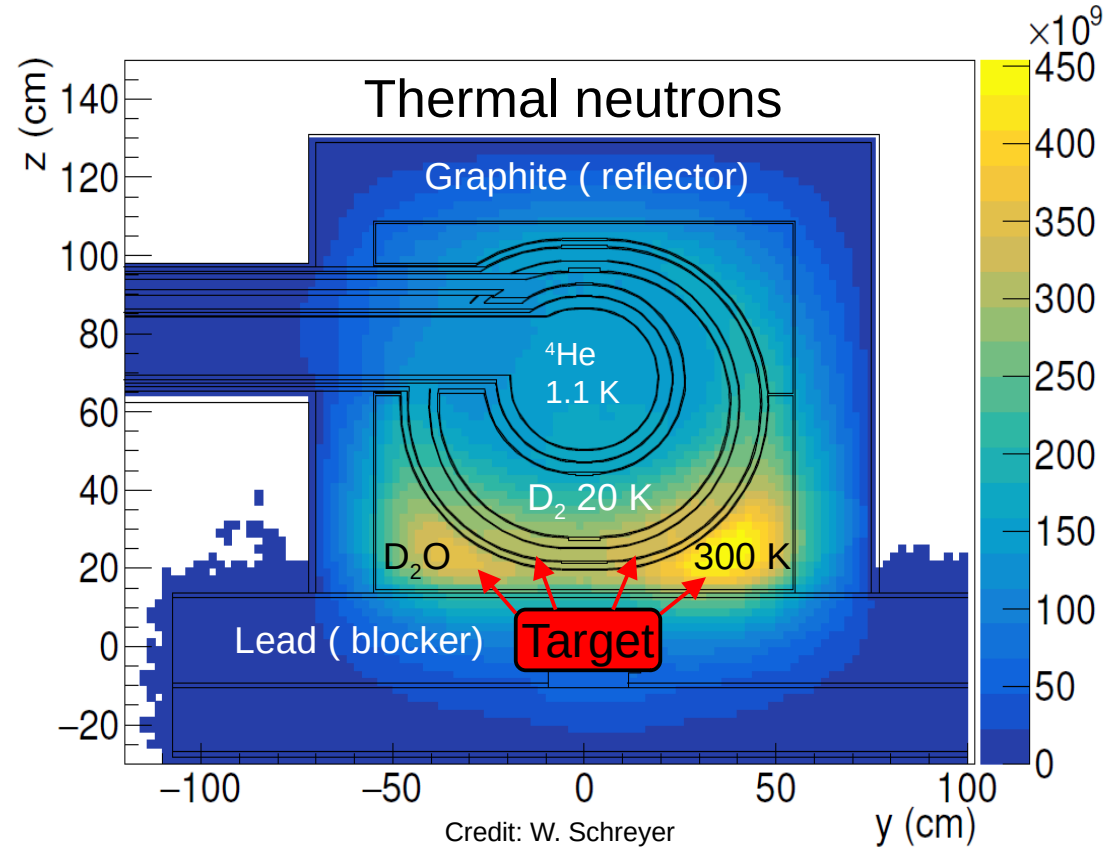

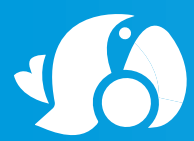

Moderation

- Spallation neutrons thermally equilibrate in room-temperature heavy water
- Become “thermal neutrons”
- 430 L of heavy water

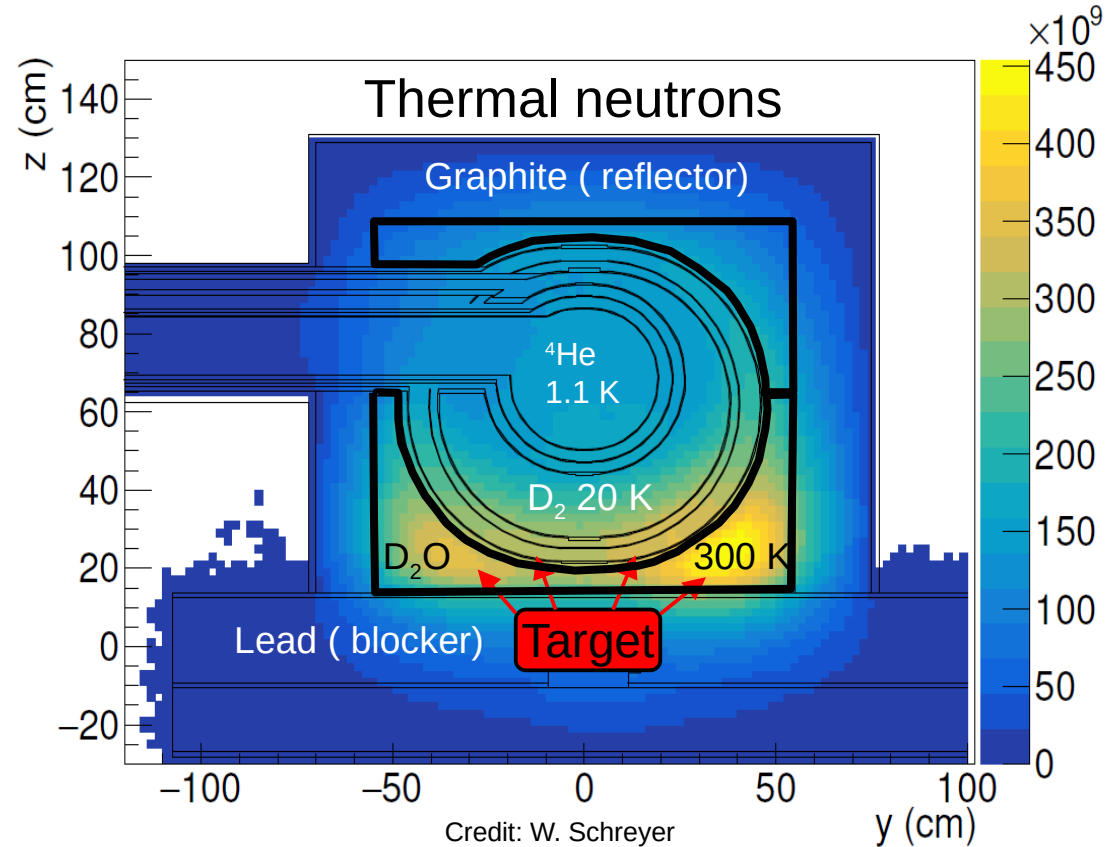

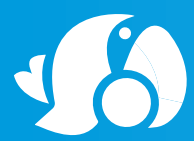

Moderation

- Thermal neutrons equilibrate with liquid D_2 at 20 Kelvin
- Become “cold neutrons”
- 125 L of liquid deuterium

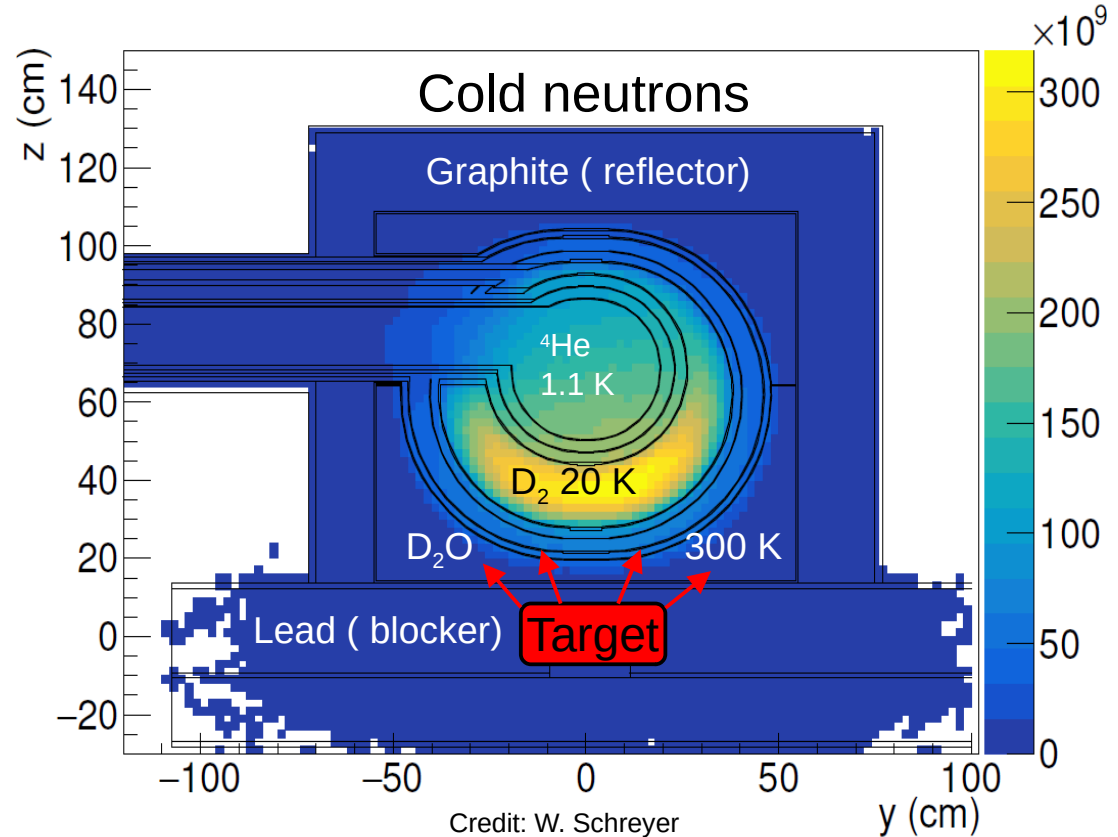

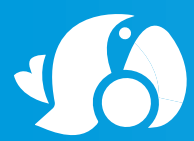

Superthermal downscattering

- For neutrons:

$T_{\text{effective}} \approx 20 \text{ K} \rightarrow \text{kinetic energy} \approx 1 \text{ meV}$

- Cold neutrons have just the right amount of energy to excite our superfluid helium!
- They don't have any more than enough, so they are halted

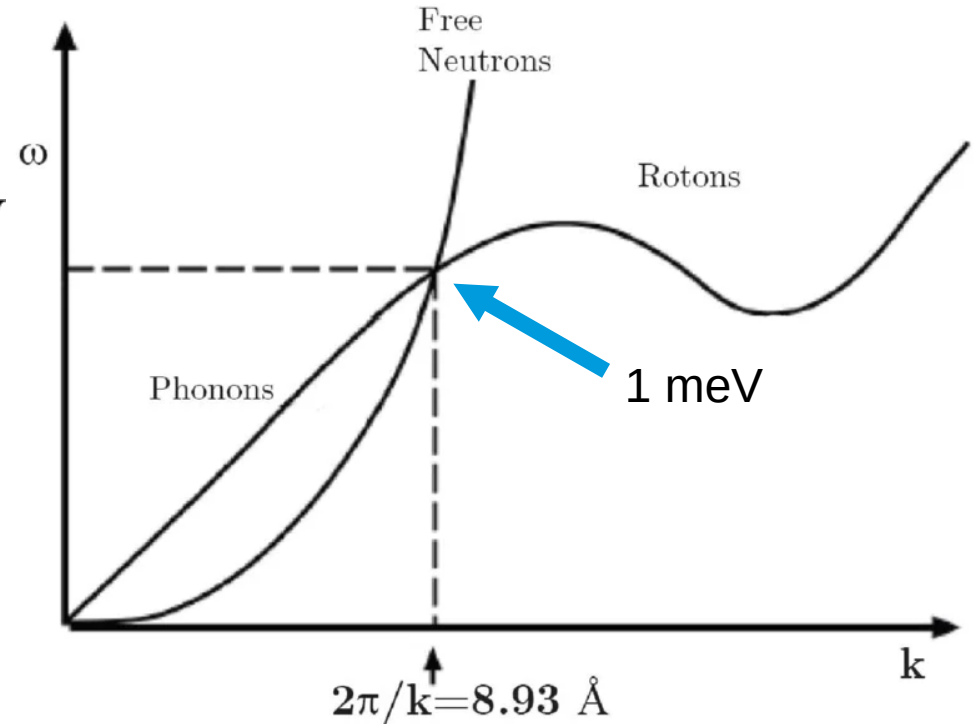

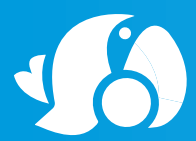

All together now

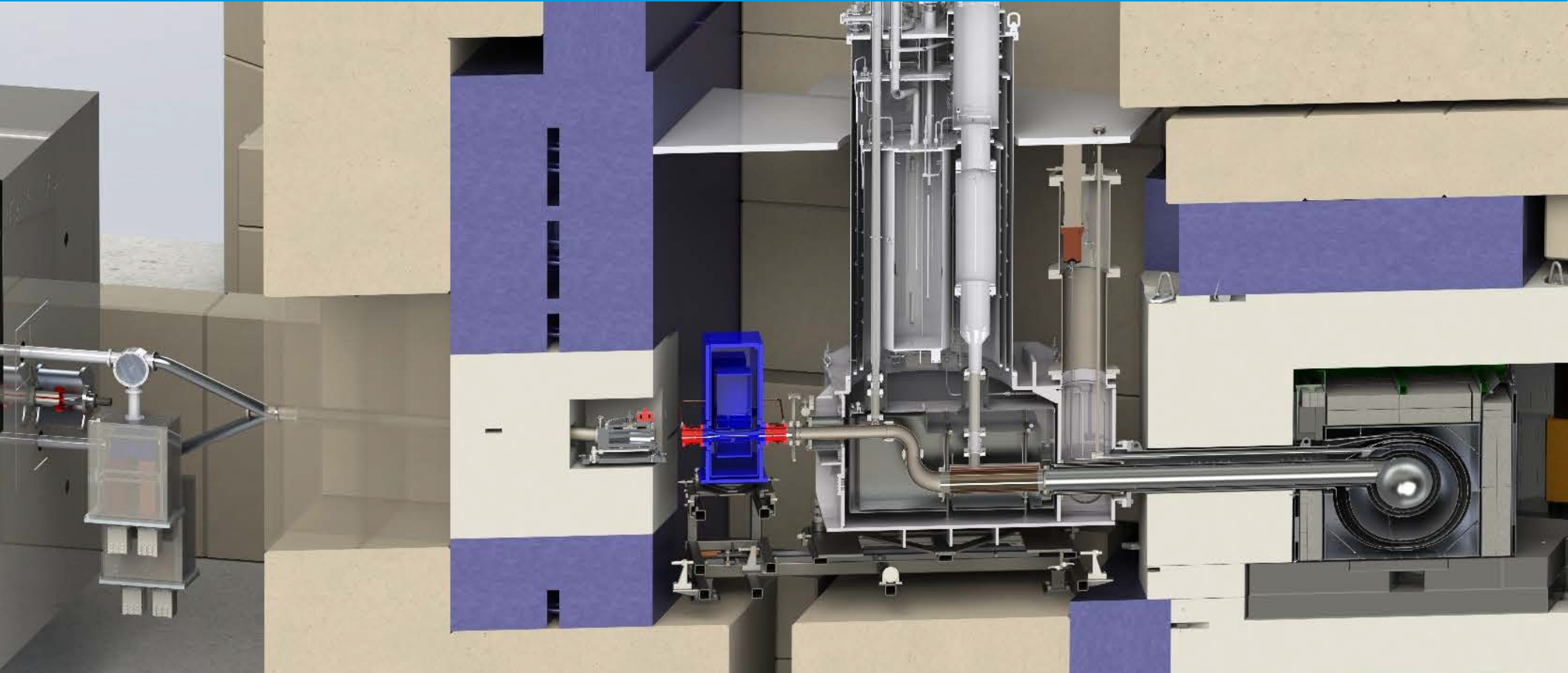

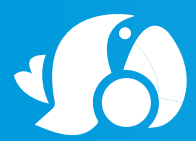

All together now

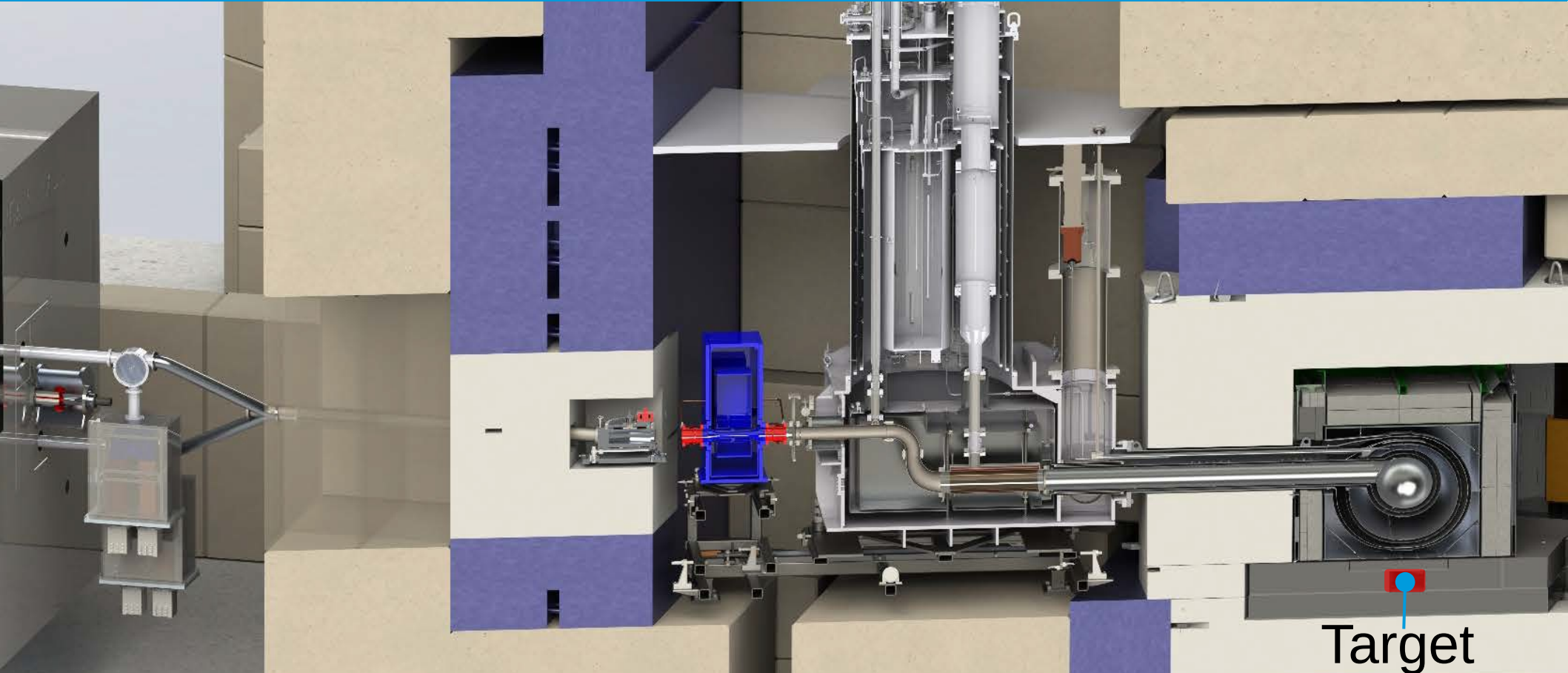

Target

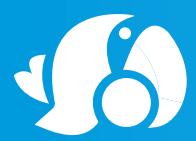

All together now

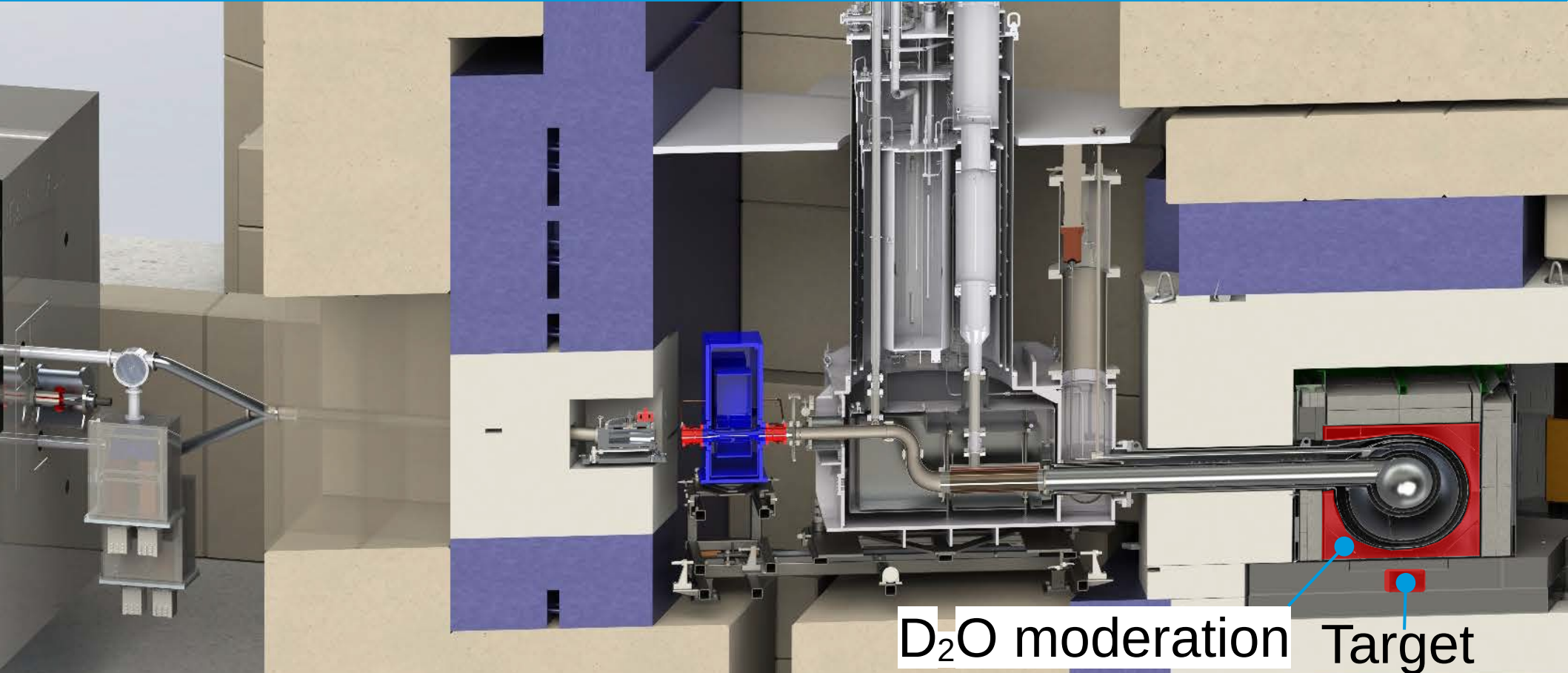

D₂O moderation

Target

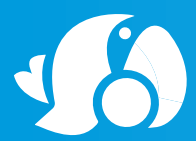

All together now

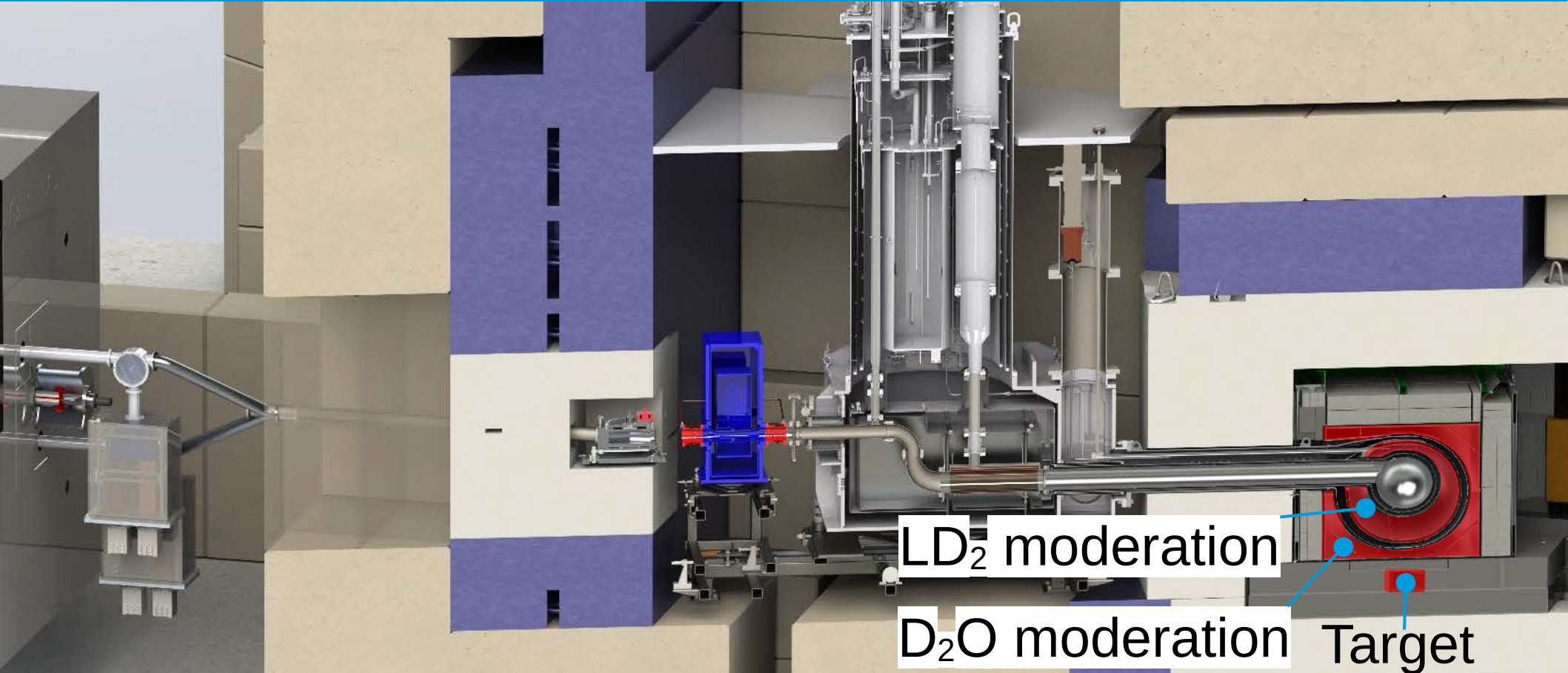

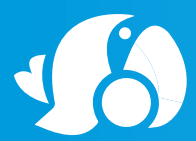

All together now

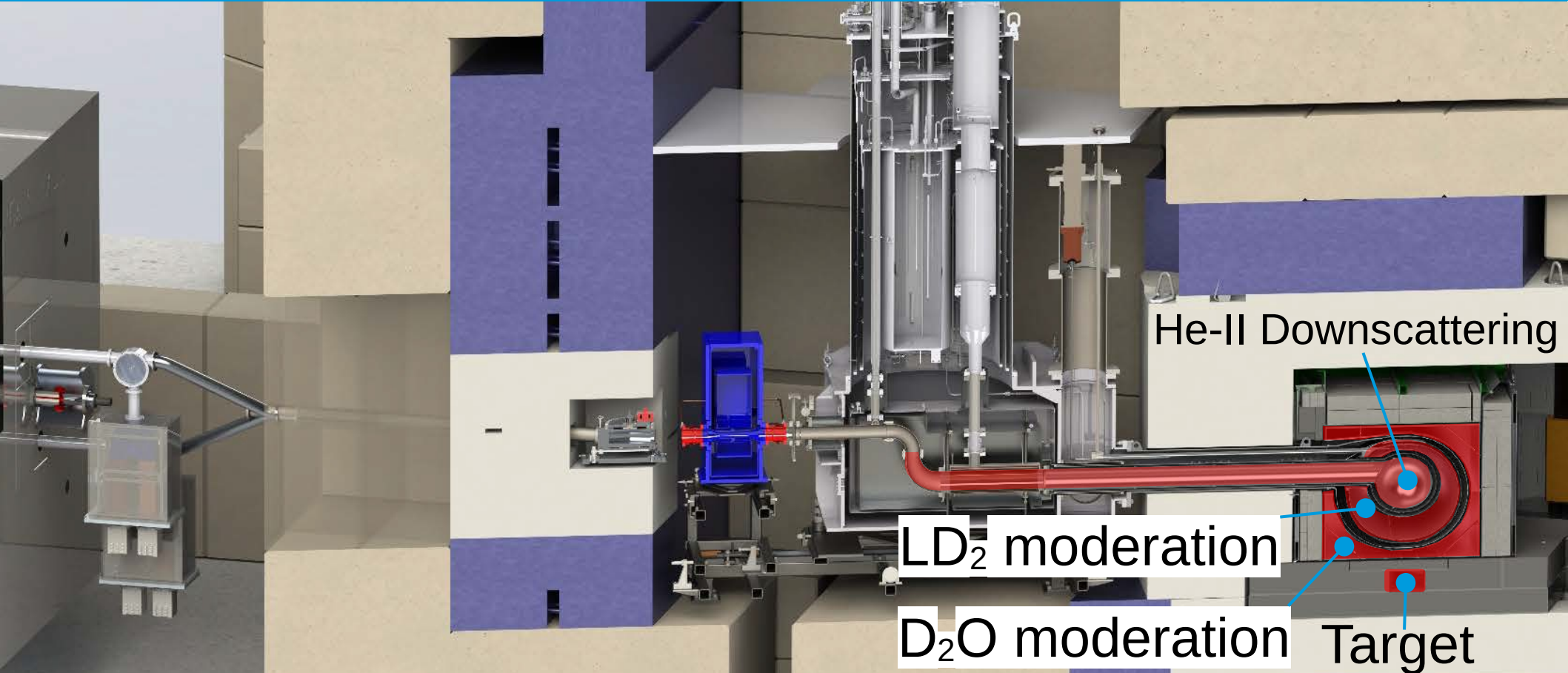

He-II Downscattering

LD_2 moderation

D_2O moderation

Target

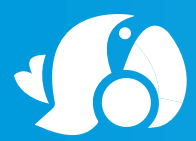

All together now

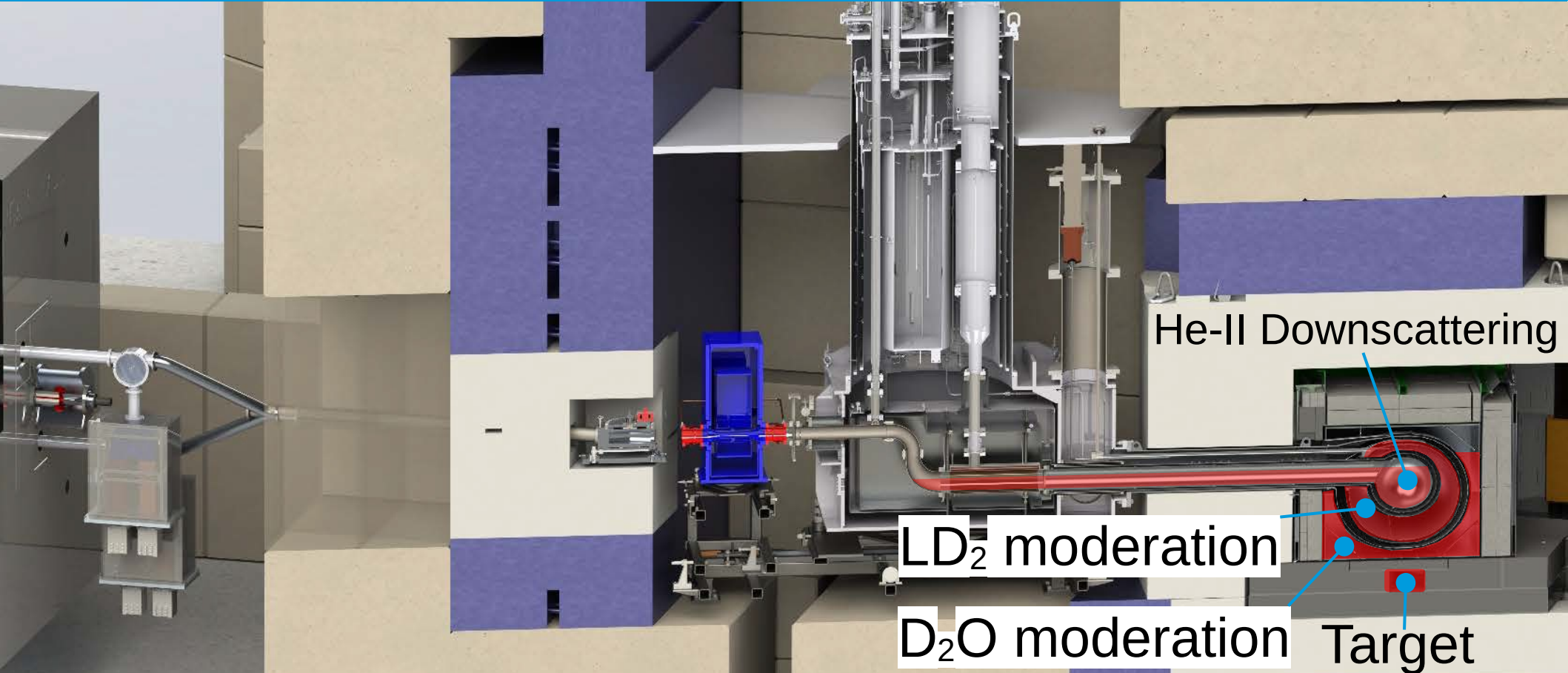

He-II Downscattering

LD₂ moderation

D₂O moderation

Target

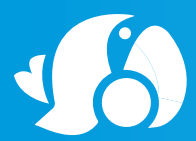

All together now

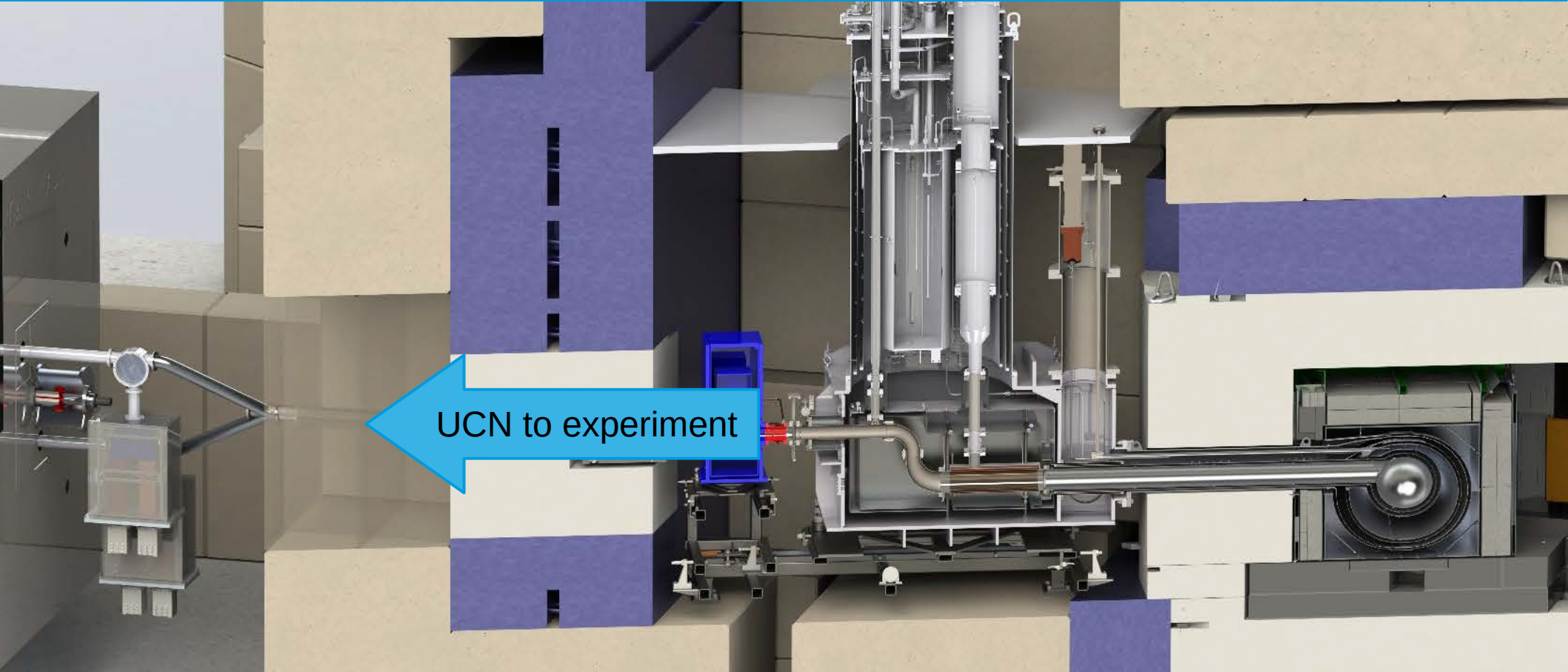

UCN to experiment

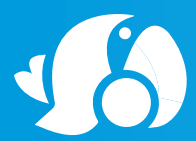

All together now

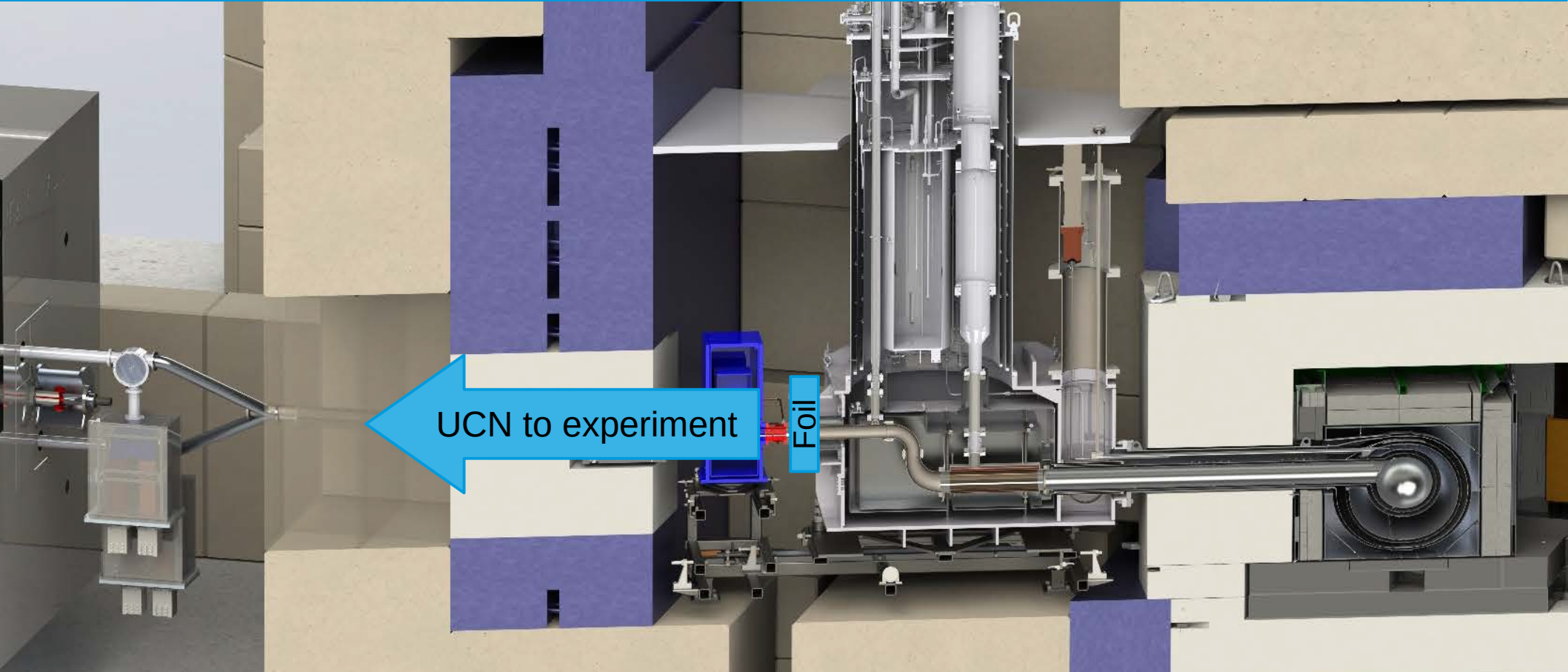

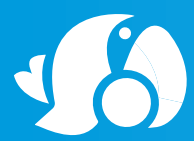

Timeline

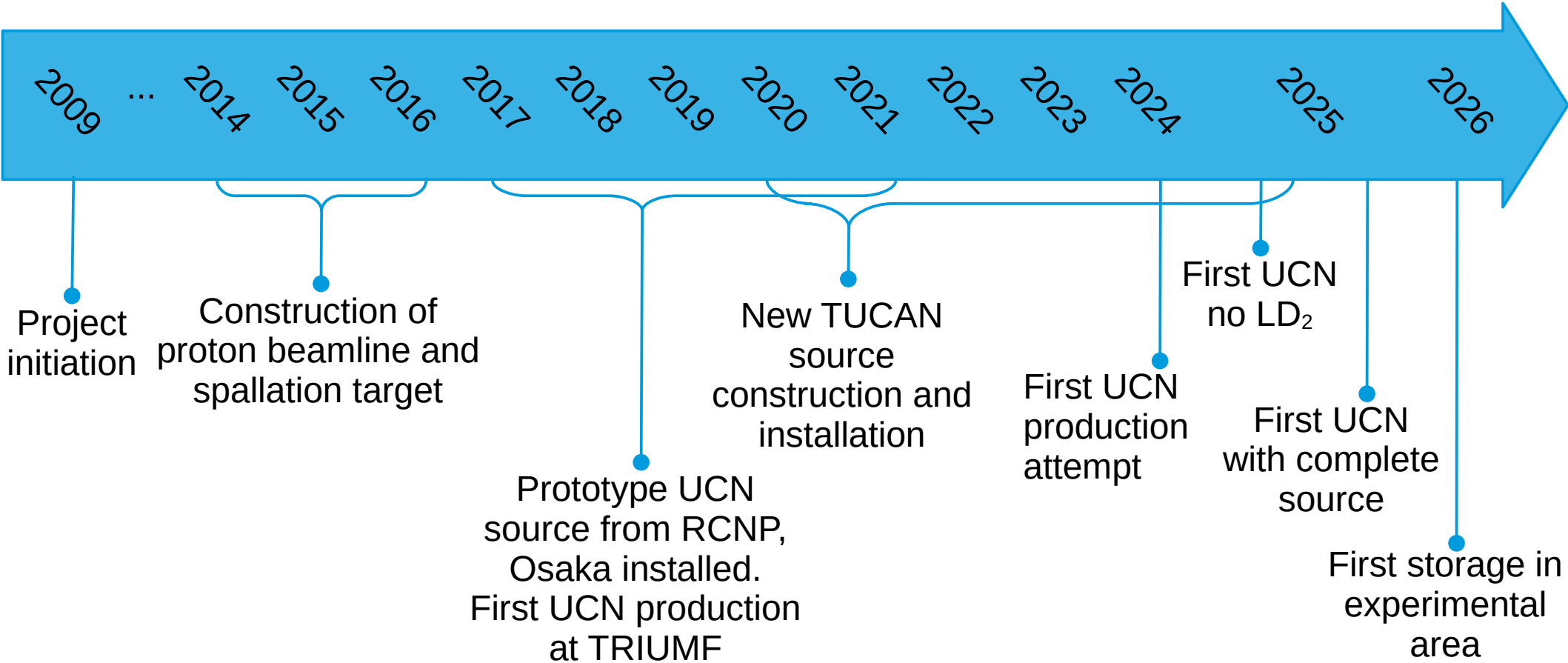

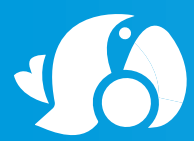

- Production run layout:

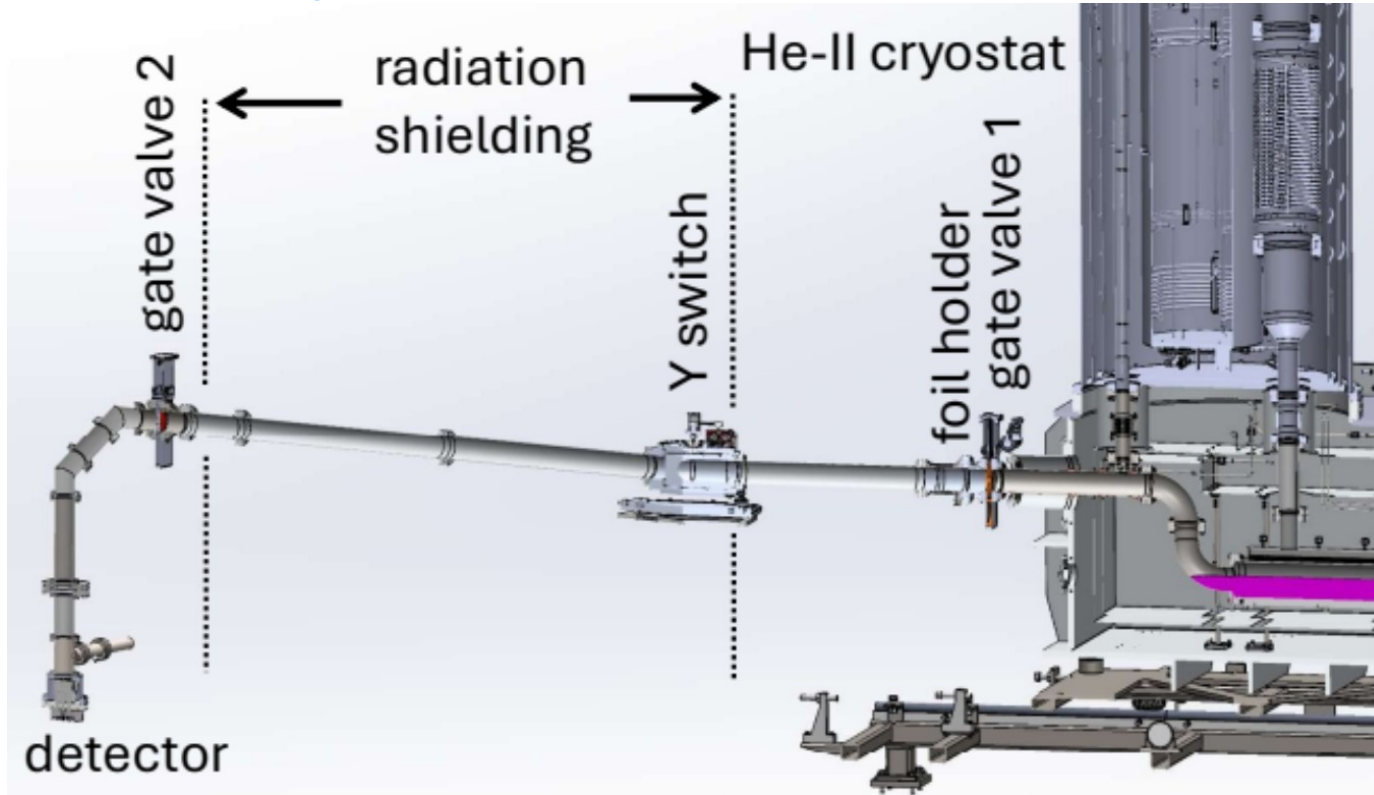

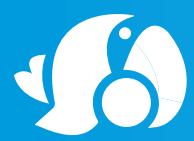

2025/2026 UCN production



Continuous production

- UCN valve open during spallation target irradiation
- 3.25×10^5 UCN/s detected at 33 μ A with 0.15 μ m Ti foil
- **6.7×10^5 UCN/s** detected at 26.6 μ A without foil

DAQ saturated[†]

Comparison:

- ILL PF2 source 2.6×10^4 UCN/s^a
- SuperSUN 2.1×10^4 UCN/s^b

^a PF2 webpage: www.ill.eu/

^b S. Degenkolb et al, 2025: <https://doi.org/10.48550/arXiv.2504.13030>

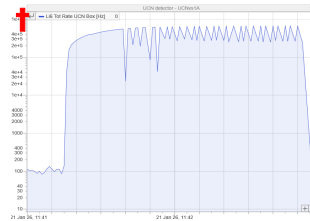
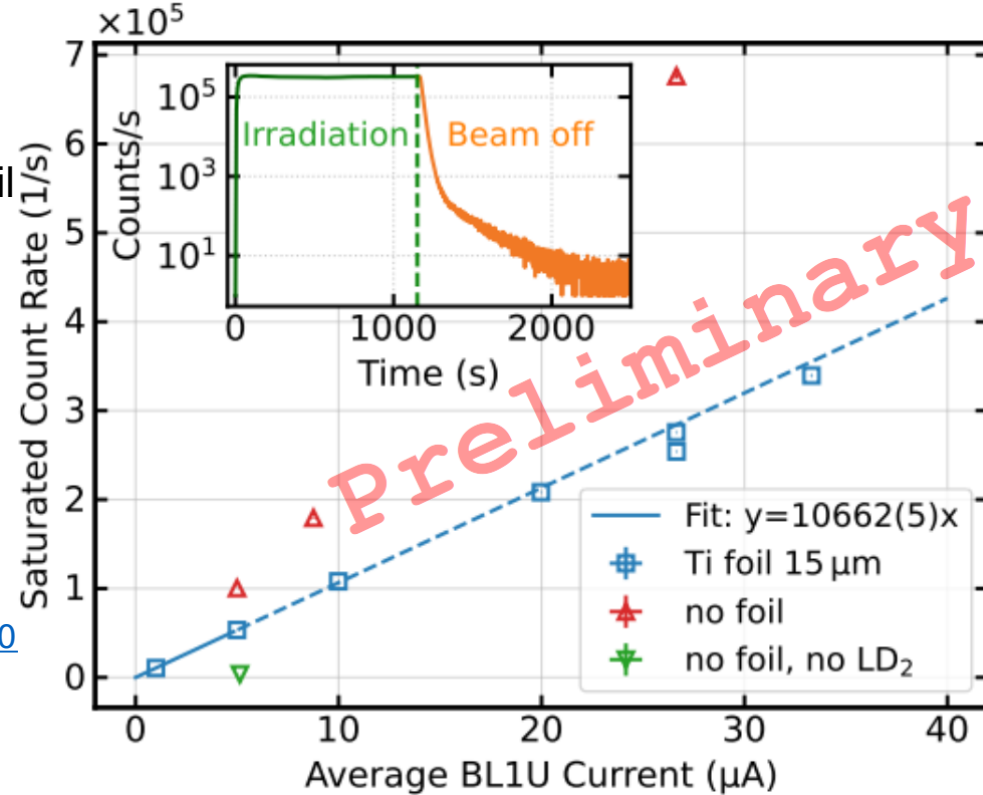

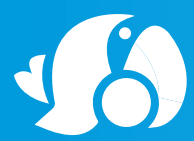

2025/2026 UCN production



60 s storage production

- **1.3×10^7 UCN counted** after 60s irradiation at $26.6 \mu\text{A}$.
- DAQ saturation at higher current.

Comparison per shot:

- PSI 5.5×10^7 UCN^a
- SuperSUN 3.9×10^6 UCN^b
- Mainz 5.4×10^5 UCN^c
- LANCSE 10^7 UCN ??^d

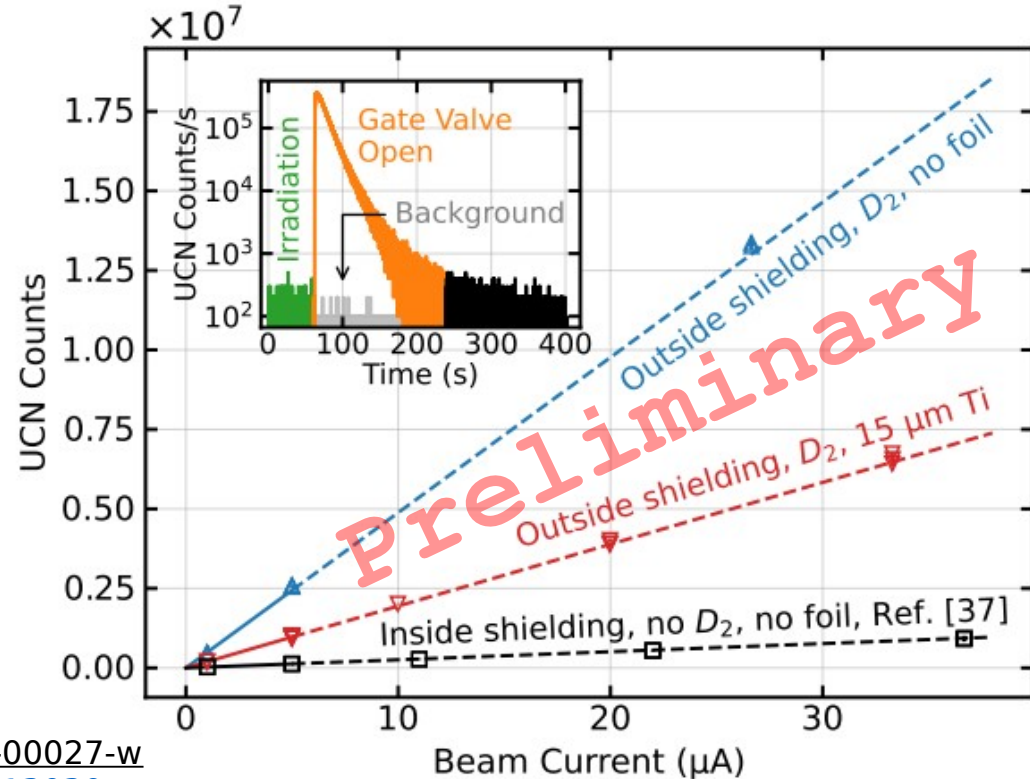

^a G. Bison et al, 2020: <https://doi.org/10.1140/epja/s10050-020-00027-w>

^b S. Degenkolb et al, 2025: <https://doi.org/10.48550/arXiv.2504.13030>

^c J. Karch et al, 2014: <https://arxiv.org/abs/1308.4610>

^d T. Ito et al, 2020: <http://dx.doi.org/10.1103/PhysRevC.97.012501> [▲] rough estimate from density in source

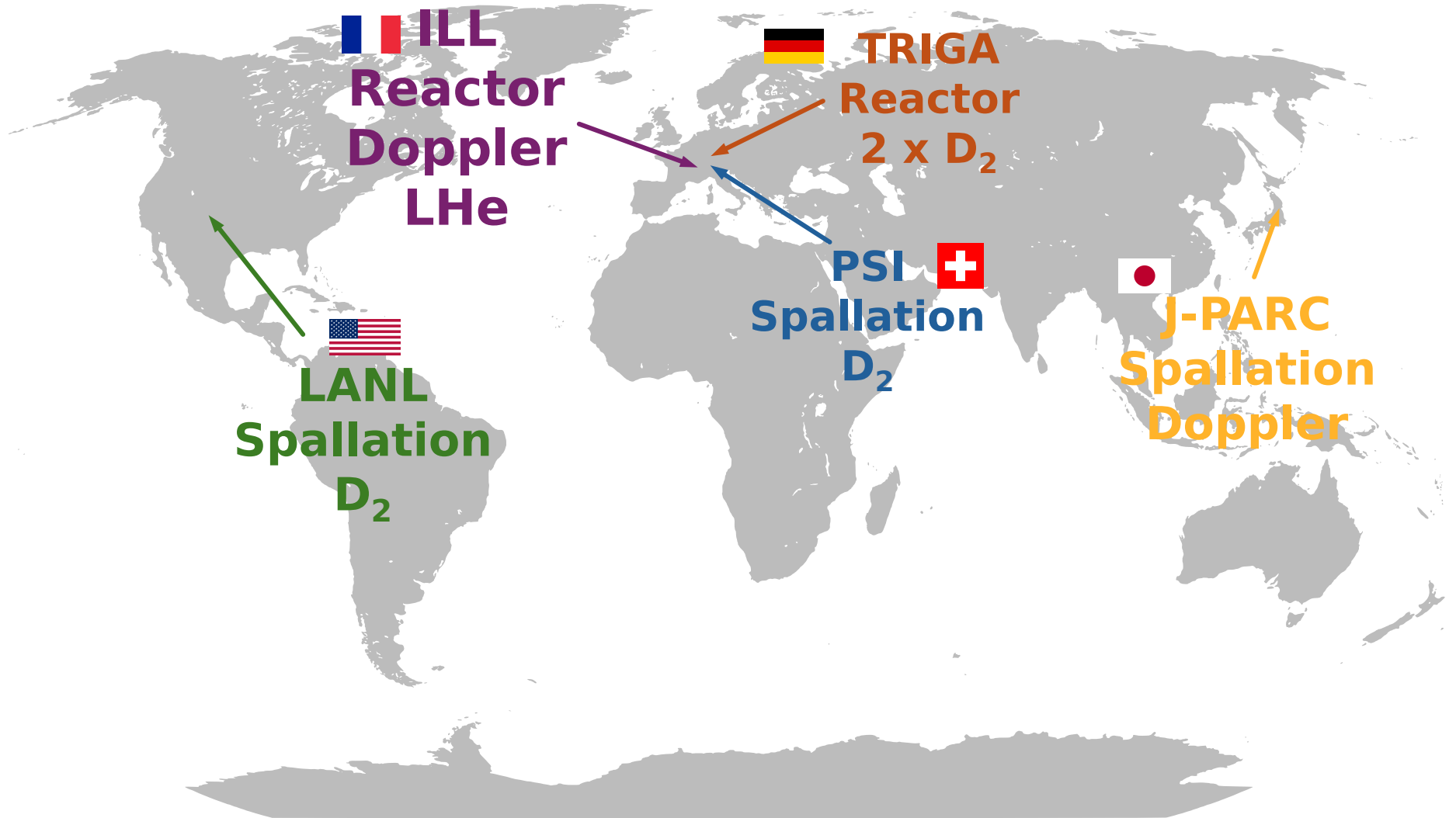



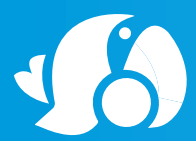

- UCN experiments are generally statistics limited
- TUCAN source will enable unprecedented statistical reach

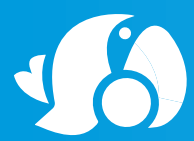

Neutron EDM



- Parametrizes neutron response to an electric field
- Probe of fundamental symmetries
- Essentially no Standard Model background

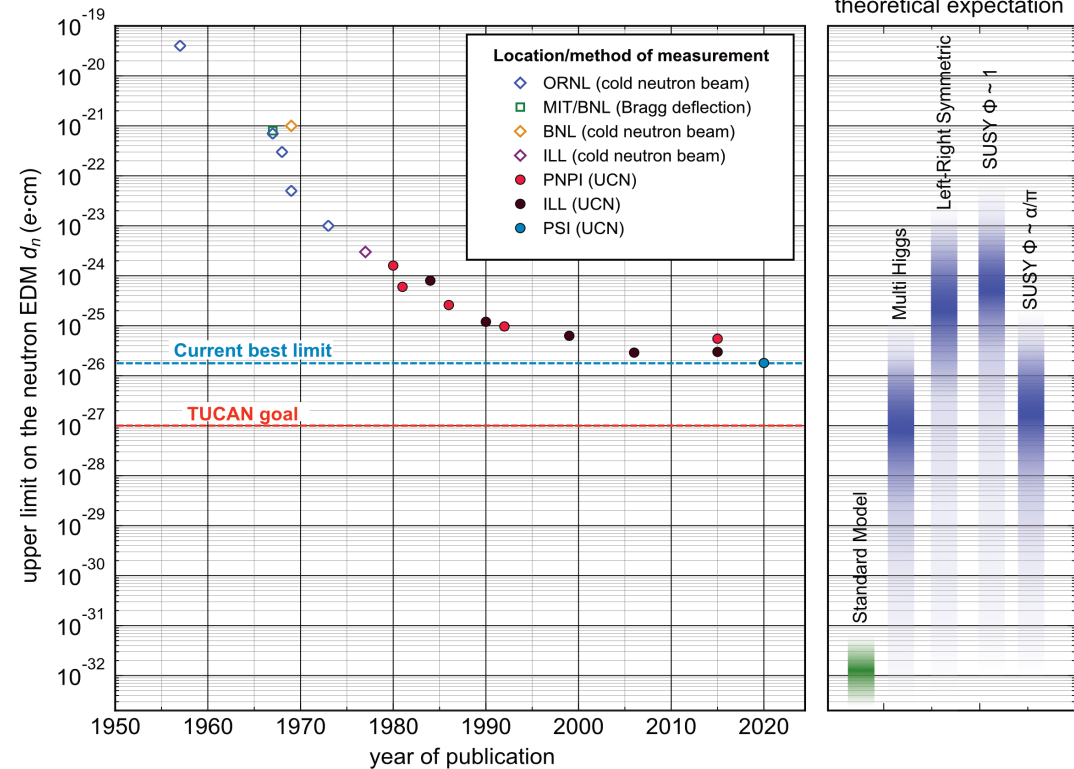

Credit: *Prospects for a neutron EDM measurement with an advanced ultracold neutron source at TRIUMF*, Takashi Higuchi, on behalf of the TUCAN collaboration, EPJ Web Conf. 262 01015 (2022)
DOI: 10.1051/epjconf/202226201015

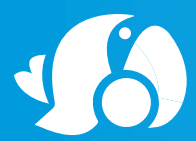

- Flagship TUCAN experiment: neutron EDM
- Statistical uncertainty:

$$\sigma_d \propto \frac{1}{|\vec{E}| T \sqrt{N}}$$

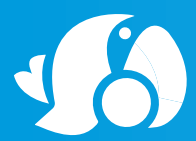

- Flagship TUCAN experiment: neutron EDM
- Statistical uncertainty:

$$\sigma_d \propto \frac{1}{|\vec{E}| T \sqrt{N}}$$

Electric field strength:
limited by HV breakdown

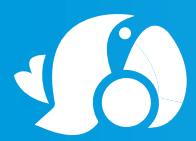

- Flagship TUCAN experiment: neutron EDM
- Statistical uncertainty:

$$\sigma_d \propto \frac{1}{|\vec{E}| T \sqrt{N}}$$

Electric field strength:
limited by HV breakdown

Precession time: limited by
depolarization & upscattering,
beta decay

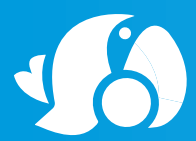

- Flagship TUCAN experiment: neutron EDM
- Statistical uncertainty:

$$\sigma_d \propto \frac{1}{|\vec{E}| T \sqrt{N}}$$

Electric field strength: limited by HV breakdown

Precession time: limited by depolarization & upscattering, beta decay

Total neutrons: limited by source production

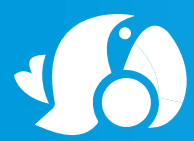

- Flagship TUCAN experiment: neutron EDM
- Statistical uncertainty:

$$\sigma_d \propto \frac{1}{|\vec{E}| T \sqrt{N}}$$

Electric field strength: limited by HV breakdown

Precession time: limited by depolarization & upscattering, beta decay

Total neutrons: limited by source production

Need to store lots of neutrons as long as we can!

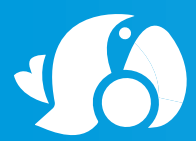

EDM storage trials

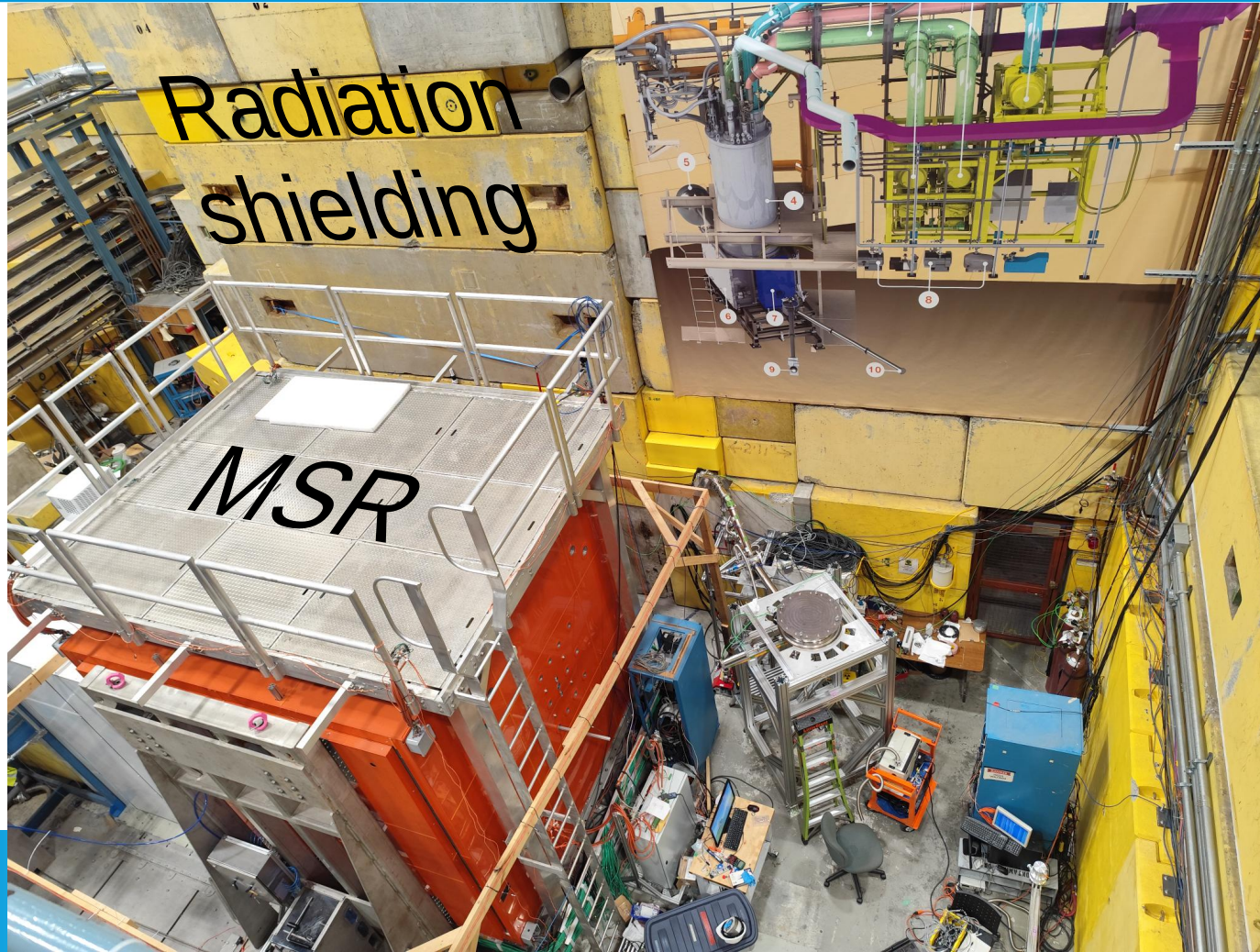

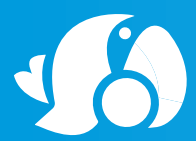

EDM storage trials

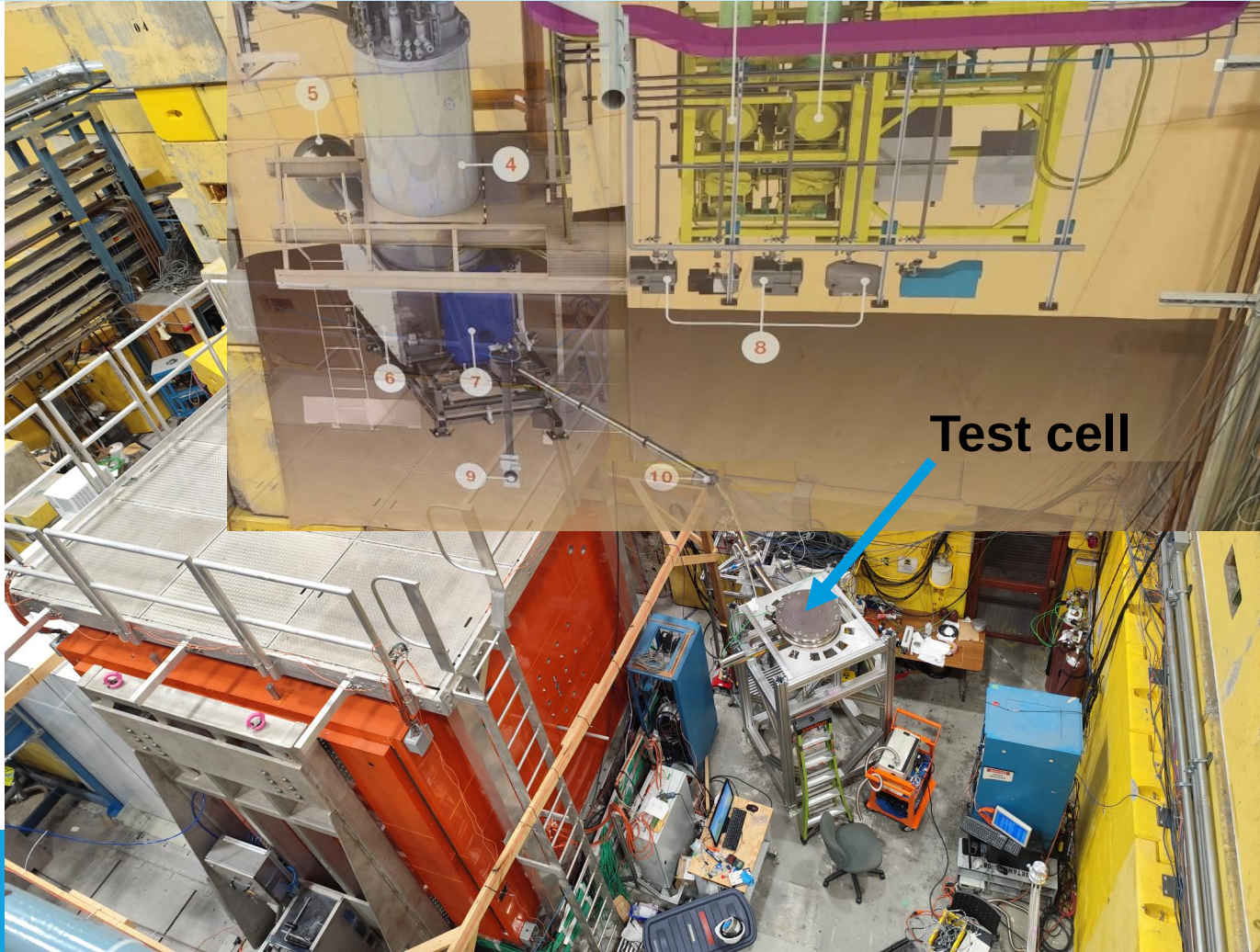

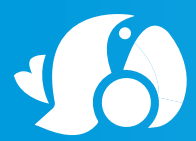

EDM storage trials



- Filling

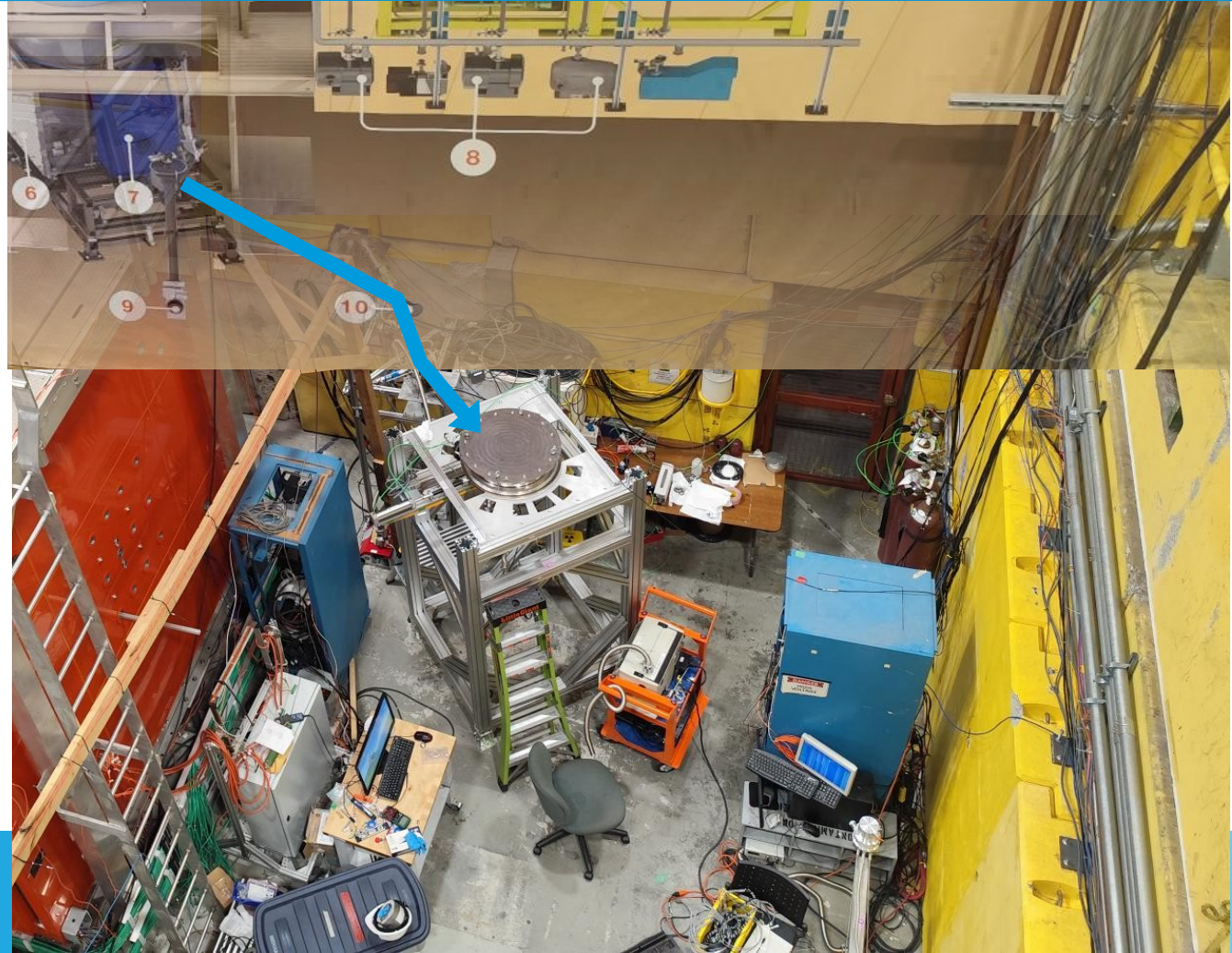

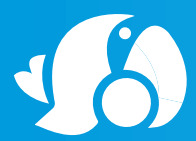

EDM storage trials



- Storage

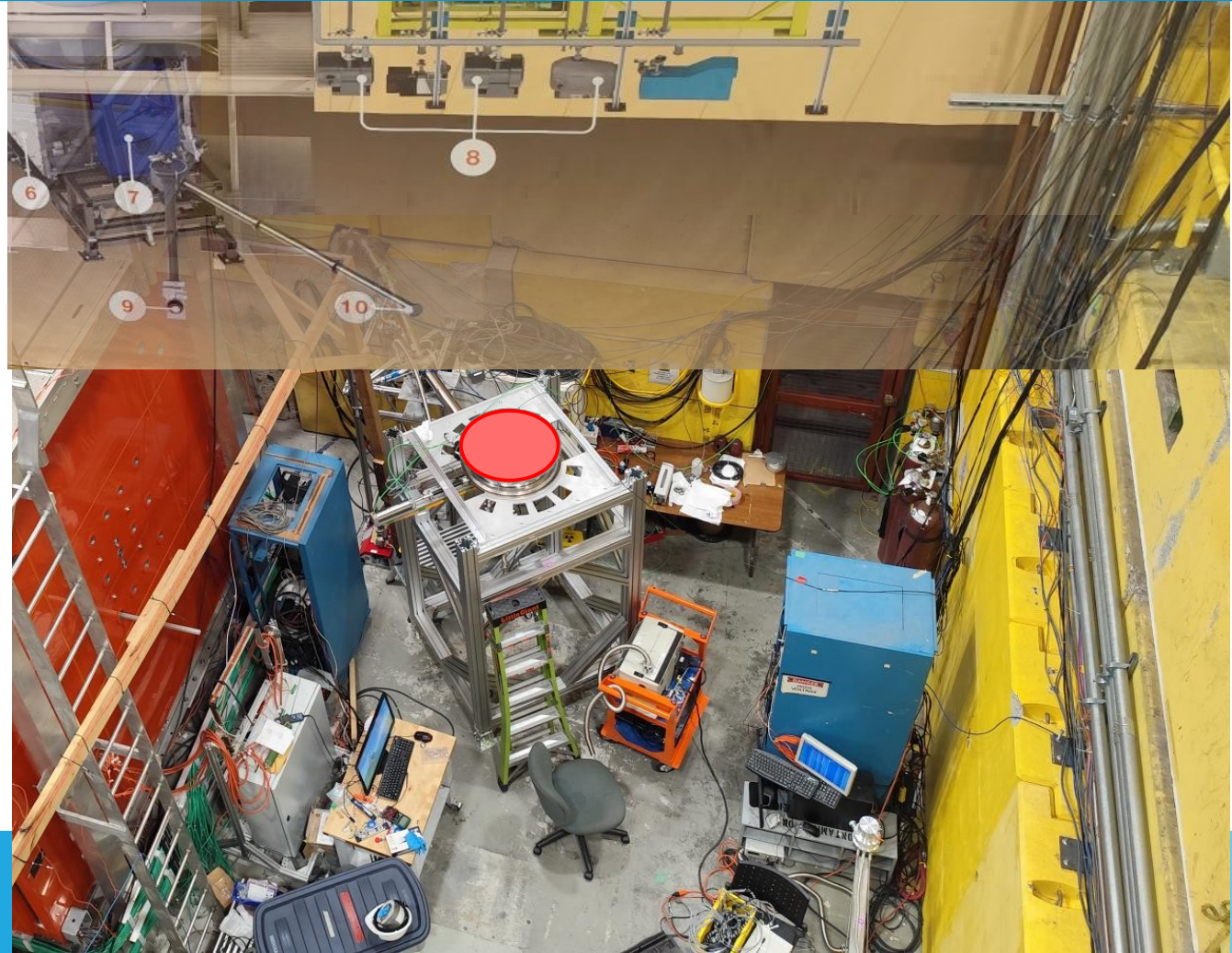

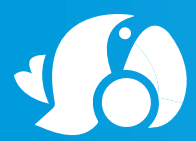

EDM storage trials



- Counting

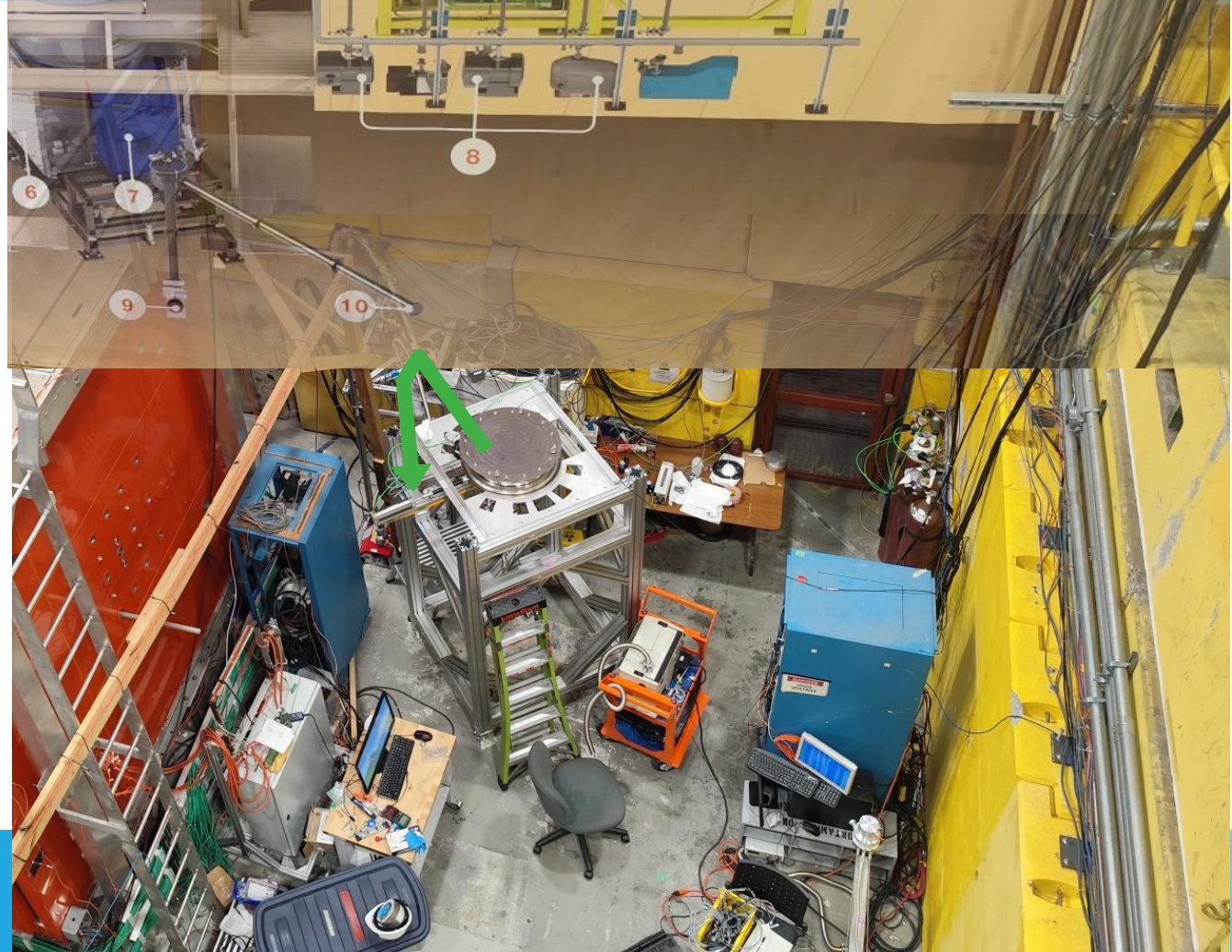

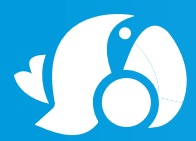

EDM storage trials

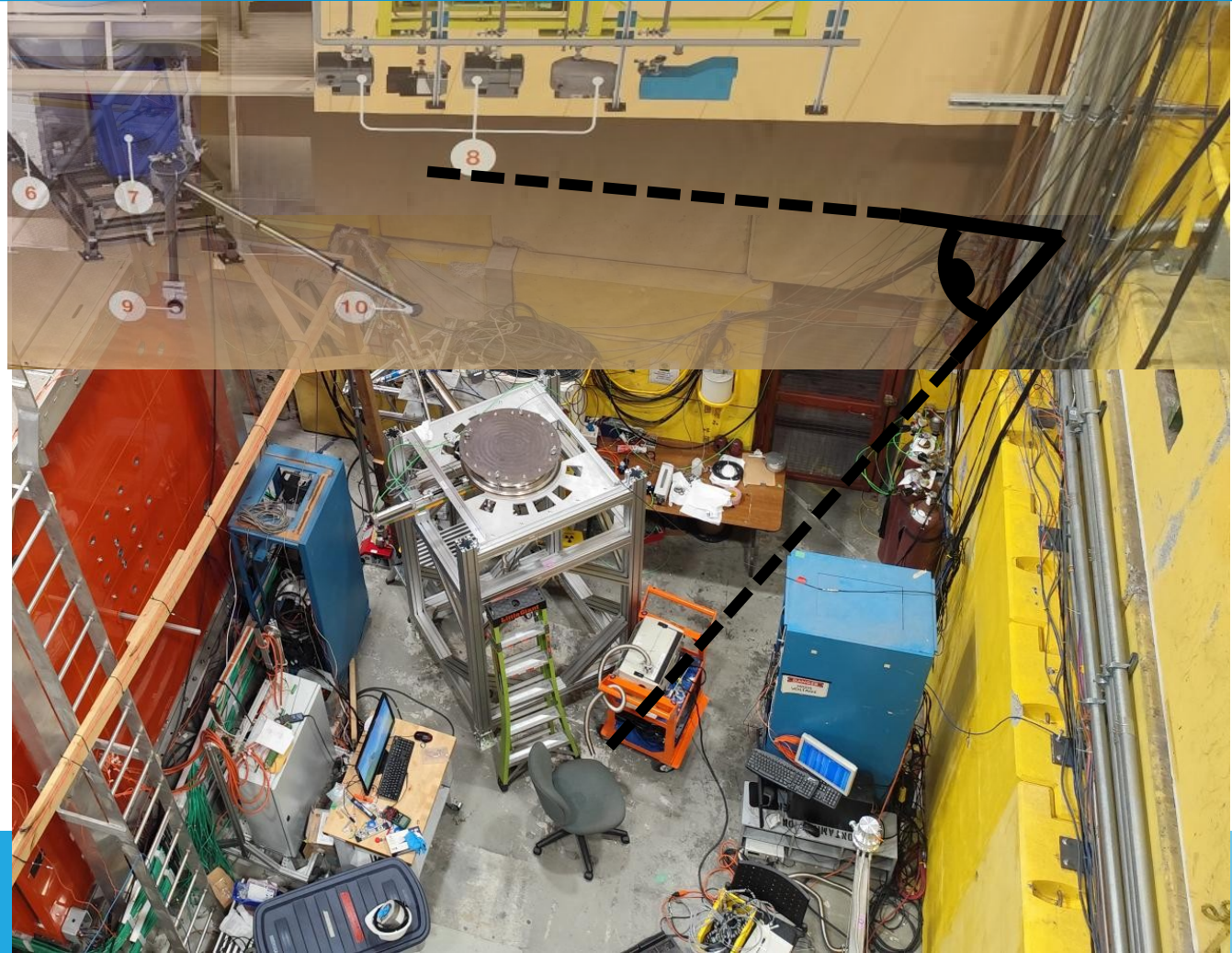



EDM storage trials

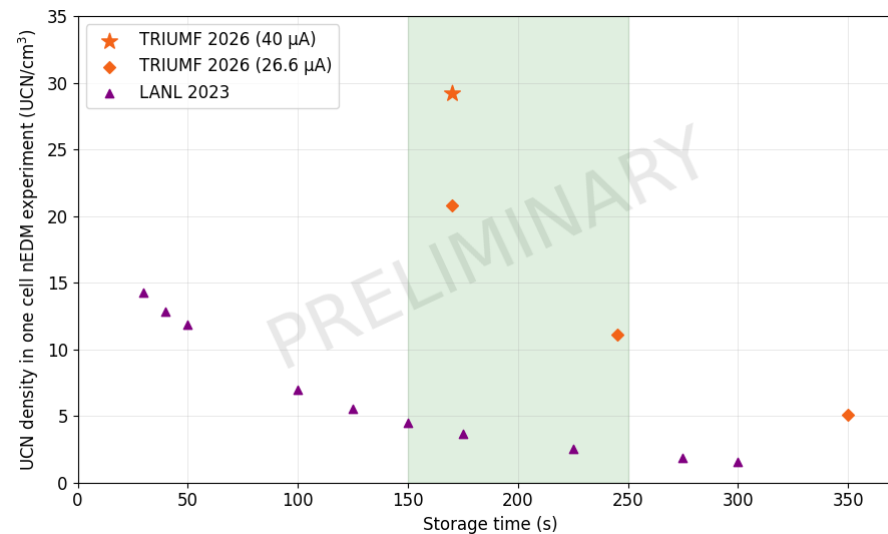
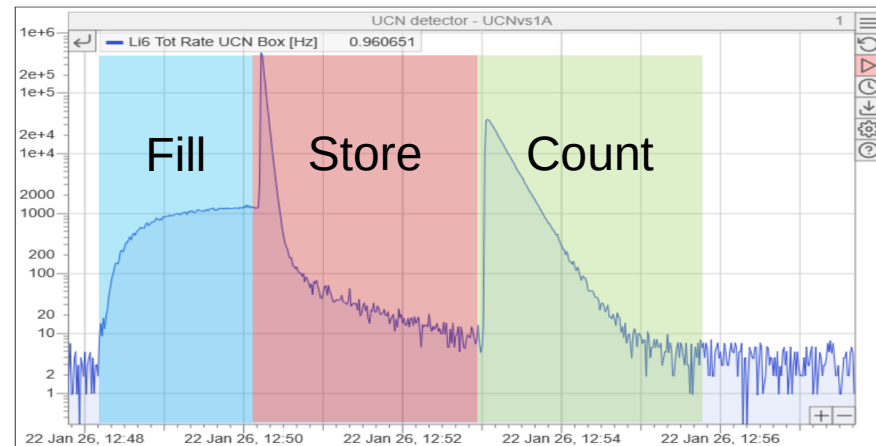
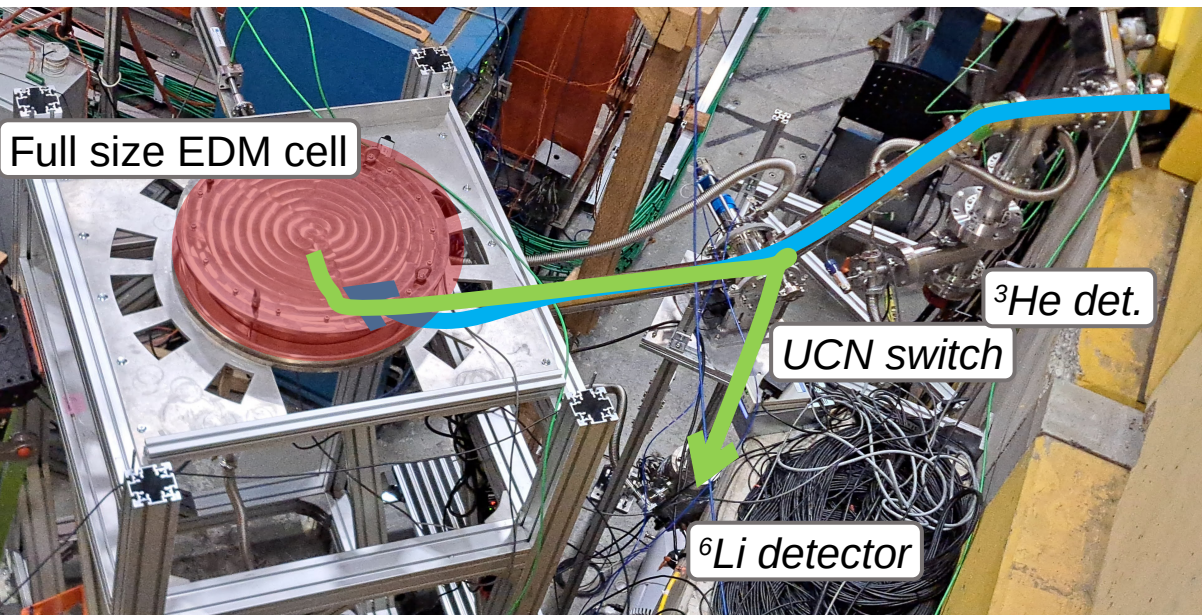

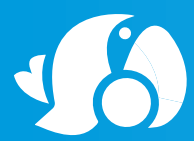

EDM storage trials

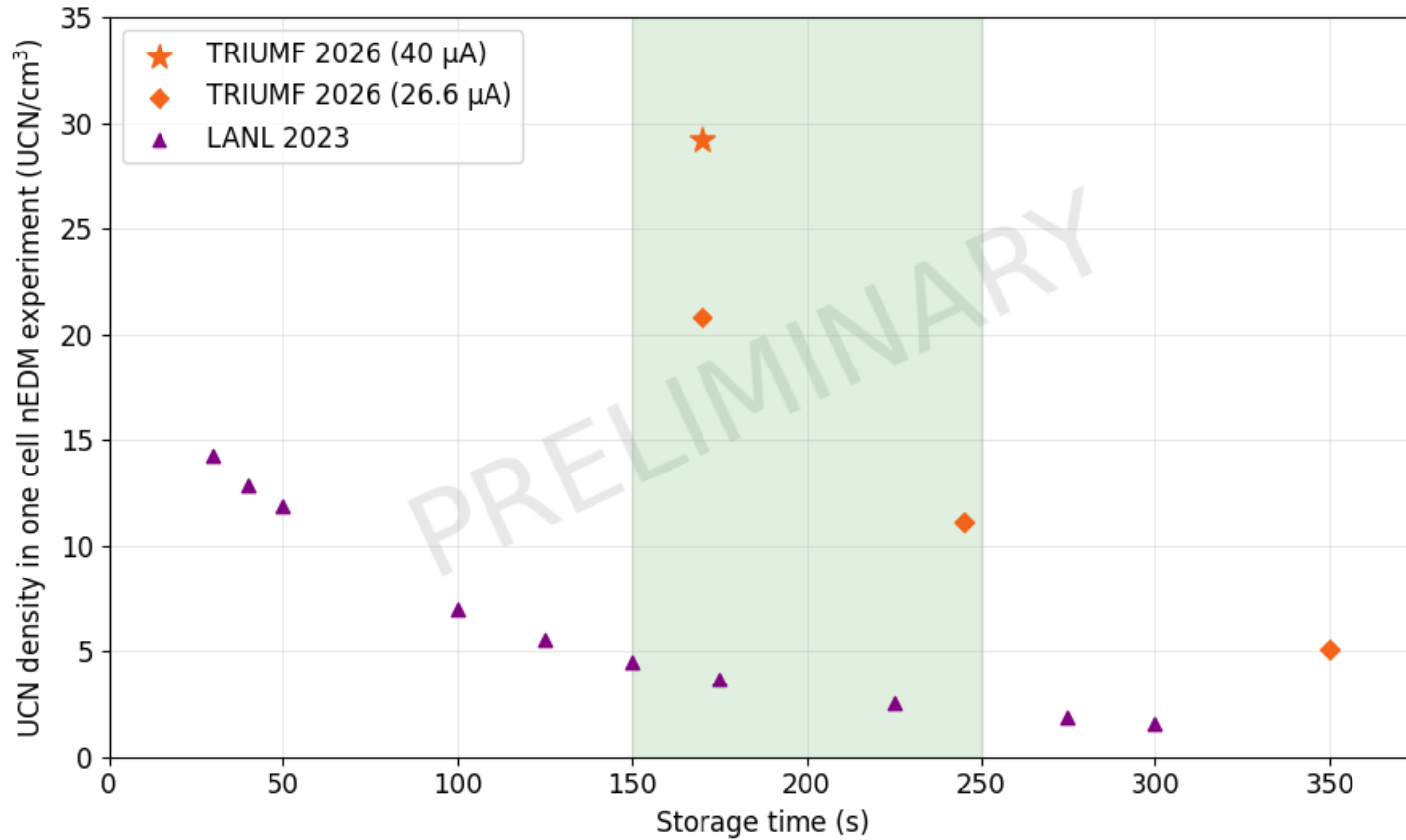

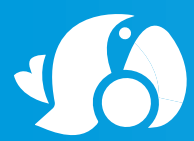

Conclusion



- The TUCAN collaboration has built and commissioned the most intense UCN source
- We stored a record density of UCN in an experimental cell
- nEDM measurement to begin in 2027
- Source characterization paper coming soon

Acknowledgements



SIMON FRASER UNIVERSITY



University of Manitoba



THE UNIVERSITY OF WINNIPEG



NAGOYA UNIVERSITY



UNIVERSITY OF SASKATCHEWAN



RCNP



JSPS



TRIUMF



KEK



TUCAN
TRIUMF Ultra Cold
Advanced Neutron
Collaboration



Stewart Blusson
Quantum Matter Institute
THE UNIVERSITY OF BRITISH COLUMBIA

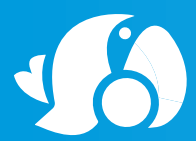

End



Questions?



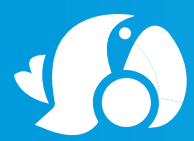

Extras: Heat Exchanger

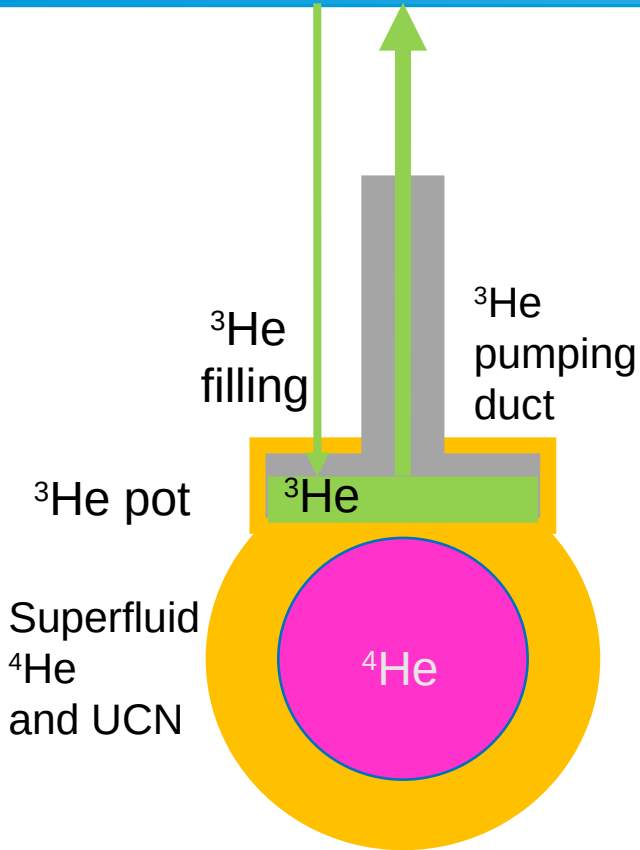

- Cold liquid ^3He drops into a pot
- The boiling ^3He in the pot removes heat from the superfluid ^4He via a copper heat exchanger (HEX1)
- Boiling ^3He is pumped away by very big pumps

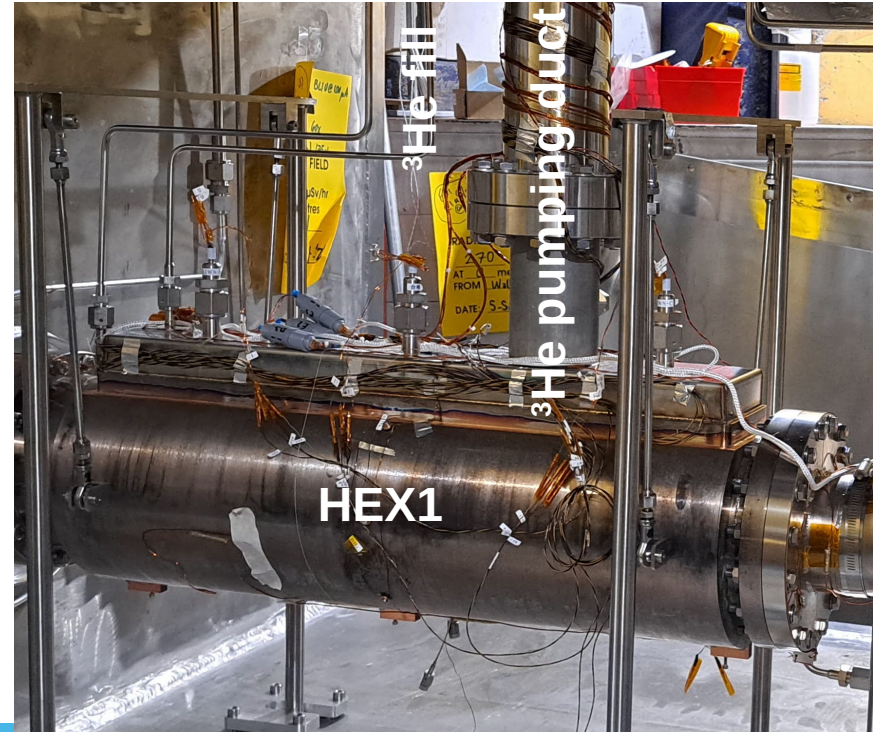

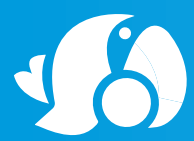

Extras: ^3He Cryostat Pumping



The 4K pot is filled by the $^{\text{nat}}\text{He}$ purifier with a ~ 40 l/h capability.

The 1K pot and ^3He are cooled down by the 3 sets of Busch pumps.

	Mass Flow [g/s]	Flow [m ³ /h]	Vacuum [Torr]
^3He	0.57	4650	2.5
$^{\text{nat}}\text{He}$	0.607	1900	4.83



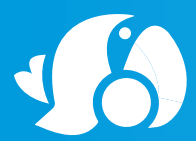

Extras: Measuring the nEDM

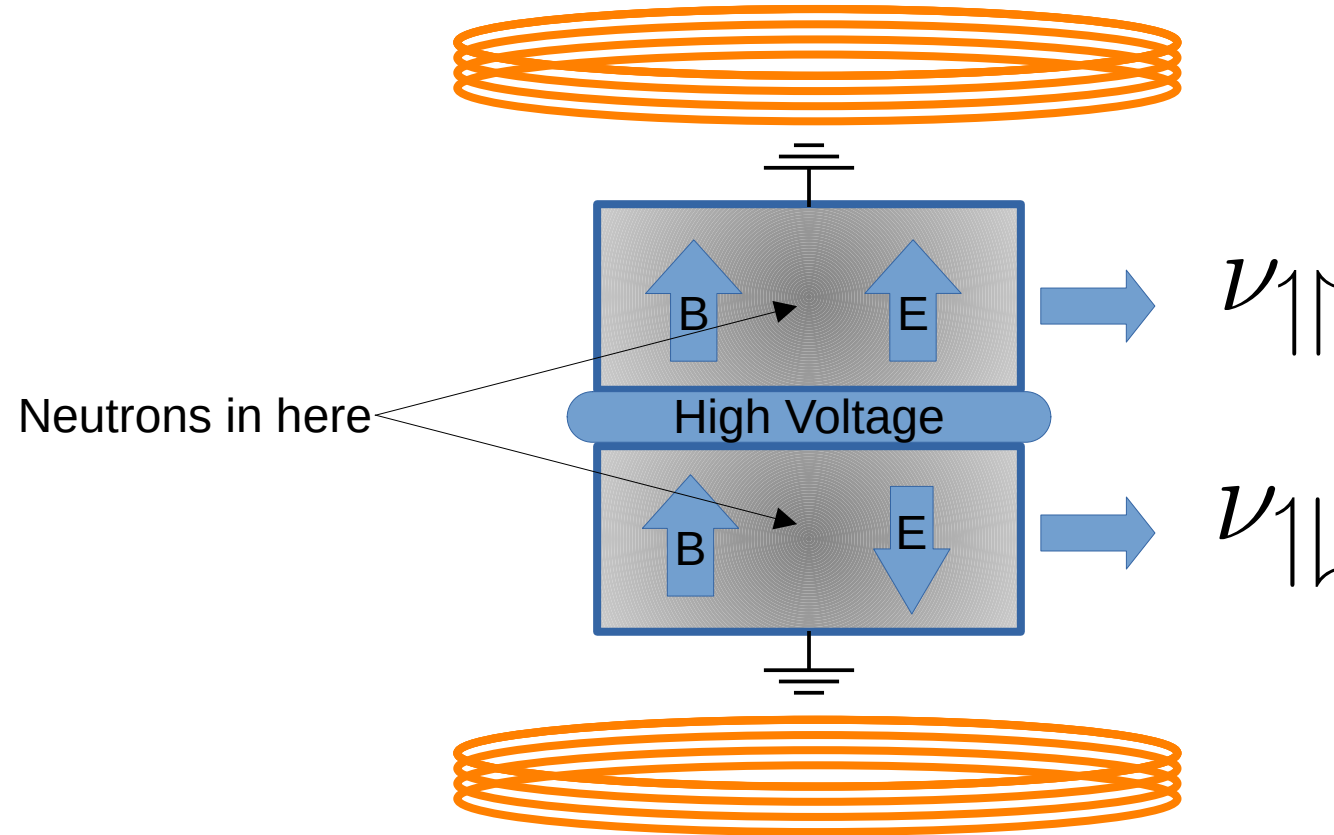

$$d_n = \frac{h(\nu_{\uparrow\uparrow} - \nu_{\uparrow\downarrow})}{4E}$$

Required sensitivity of 2 pT
over ~200 seconds

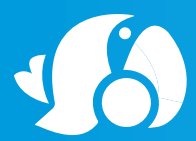

Extras: My work

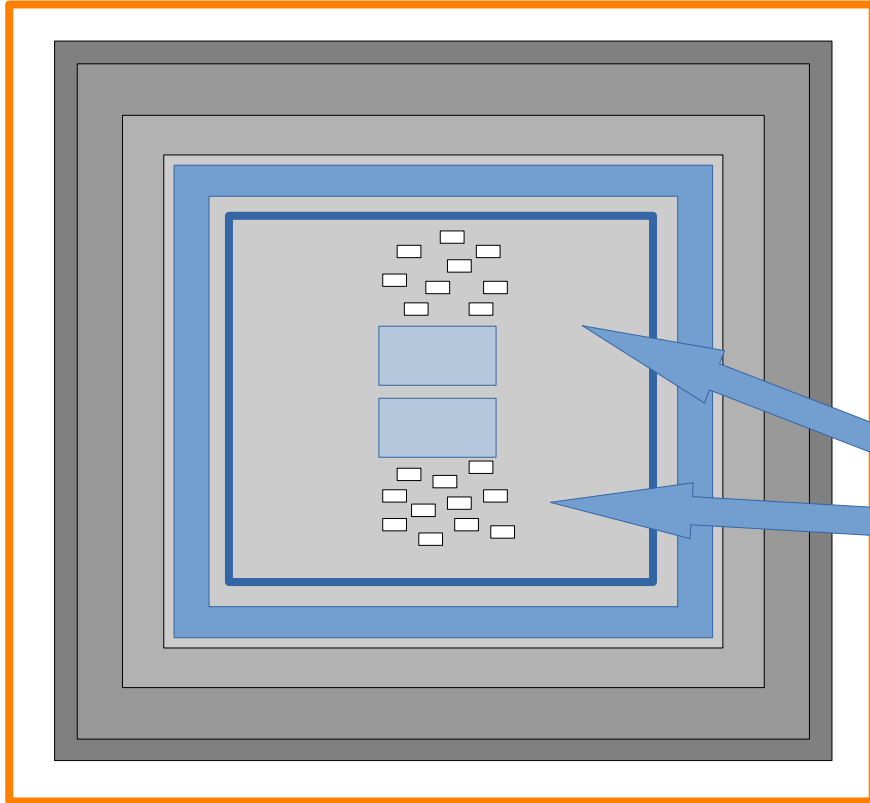

- My subsystem is the innermost layer of a magnetic systematic control onion
- Monitors the magnetic field, and gradients therein

