

The search for highly forbidden decays

Matt Stukel
Research Scientist
CAP 2026
2026/06/24

Talk Overview



1. Why these measurements are important (and fun)
2. Selected experimental efforts (KDK, KDK+, RAMPS, LUCE)

β -decay and $0\nu\beta\beta$ Theory

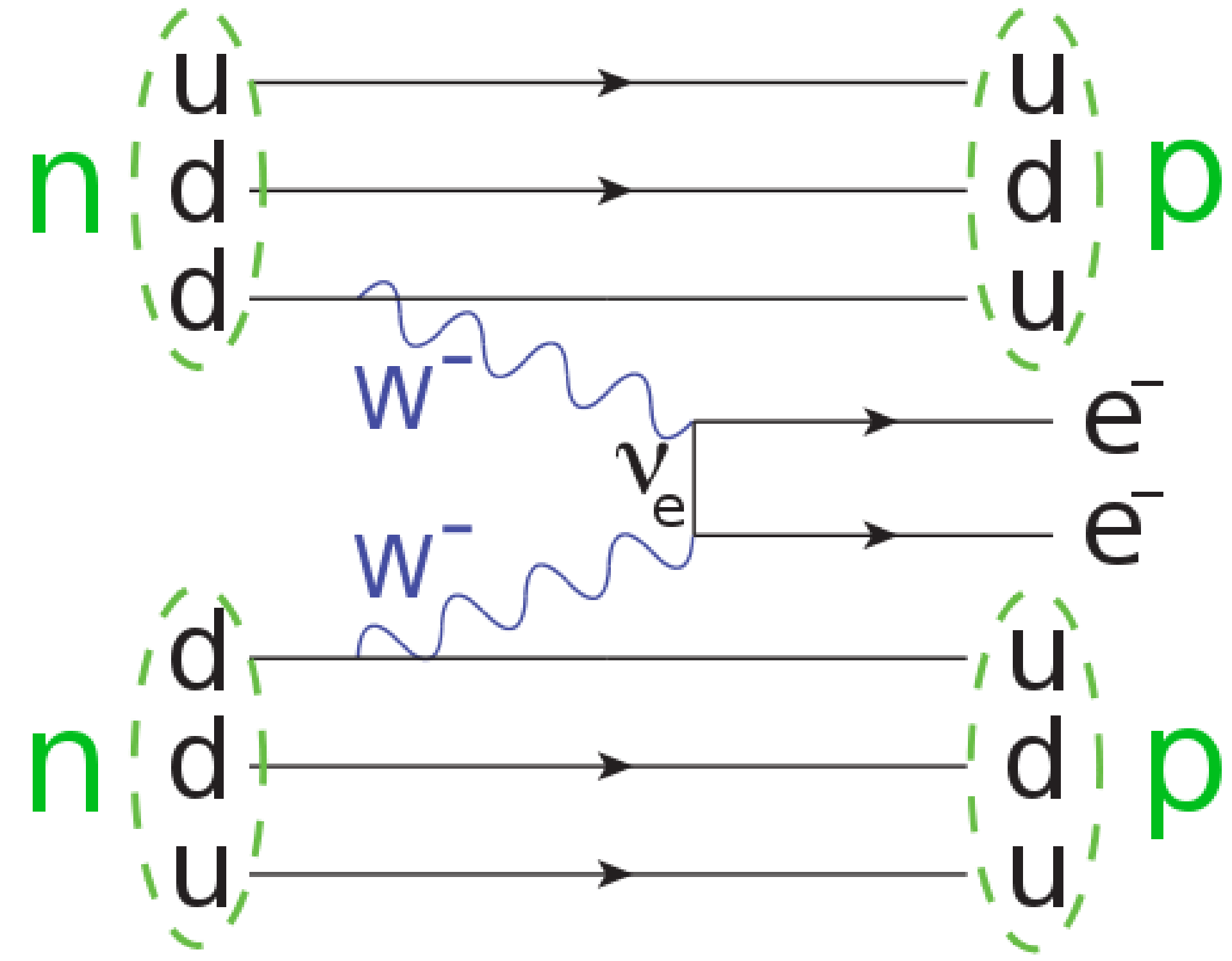
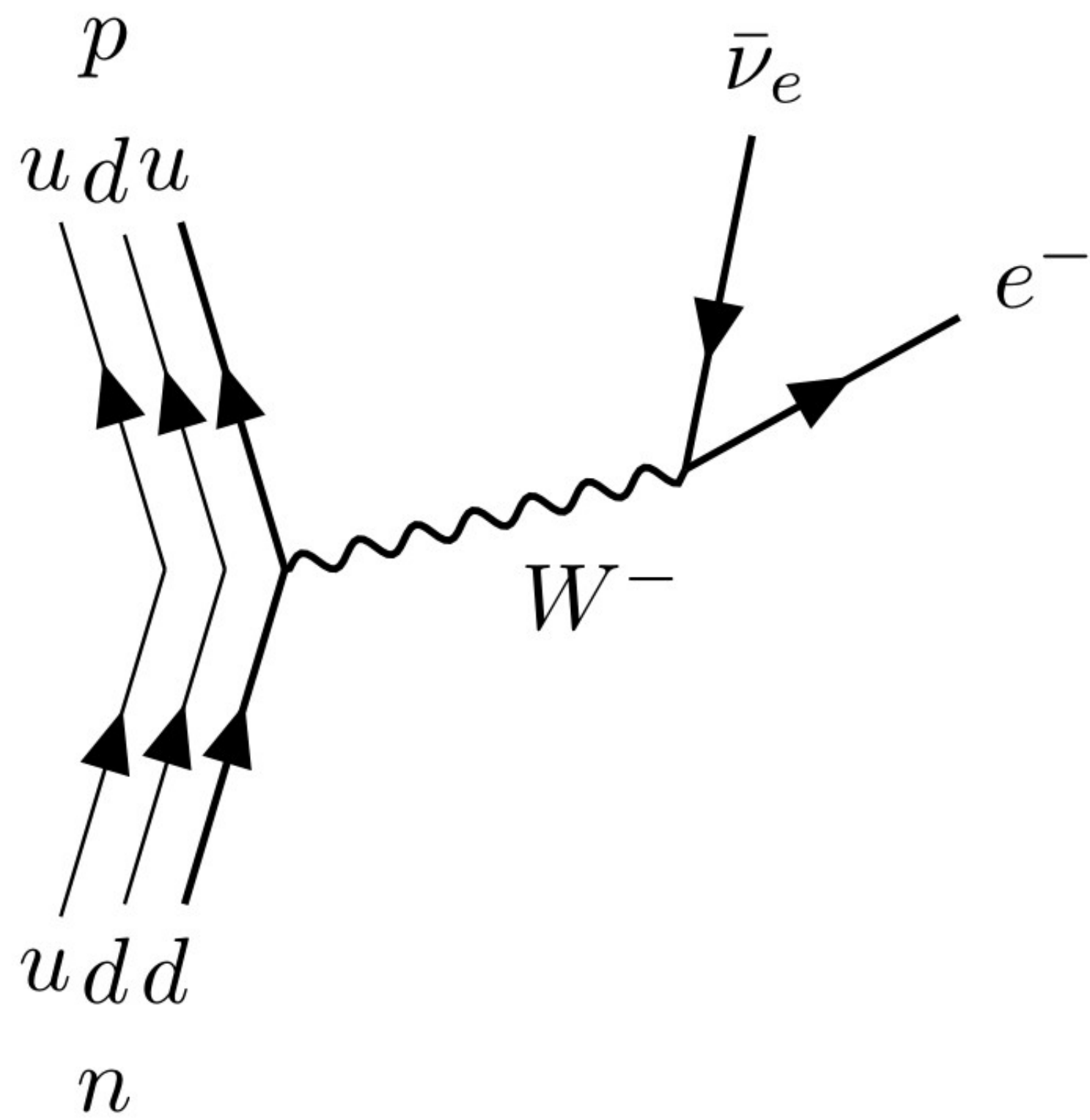

- At a fundamental nuclear level, β -decay can be considered the mutual interaction between the leptonic and hadronic currents, mediated by the $W^{+/-}$ boson.
- $0\nu\beta\beta$ is important for investigating beyond standard model physics (lepton number symmetry and baryon asymmetry)

Decay Nomenclature



	L	ΔJ	ΔP
Super Allowed	0	0	No
Allowed	0	0, 1	No
First Forbidden	1	0,1,2	Yes
Second Forbidden	2	1,2,3	No
Third Forbidden	3	2,3,4	Yes
Fourth Forbidden	4	3,4,5	No

- Gamow-Teller transition: Spins of the emitted neutrino and positron (S) are equal to 1
- Unique transition: L and S are maximally aligned
- Forbidden: Usually means long half-life

Relevance of Measurements of Long-Lived Isotopes



Isotope	Half-life (yrs)
^{40}K	1.29×10^{12}
^{50}V	2.2×10^{17}
^{138}La	1.6×10^{11}
^{123}Te	$> 10^{16} - 10^{19}$
^{180}Ta	$> 2.0 \times 10^{17}$
^{176}Lu	$> 10^{13} - 10^{14}$
^{113}Cd	$\sim 10^{15}$

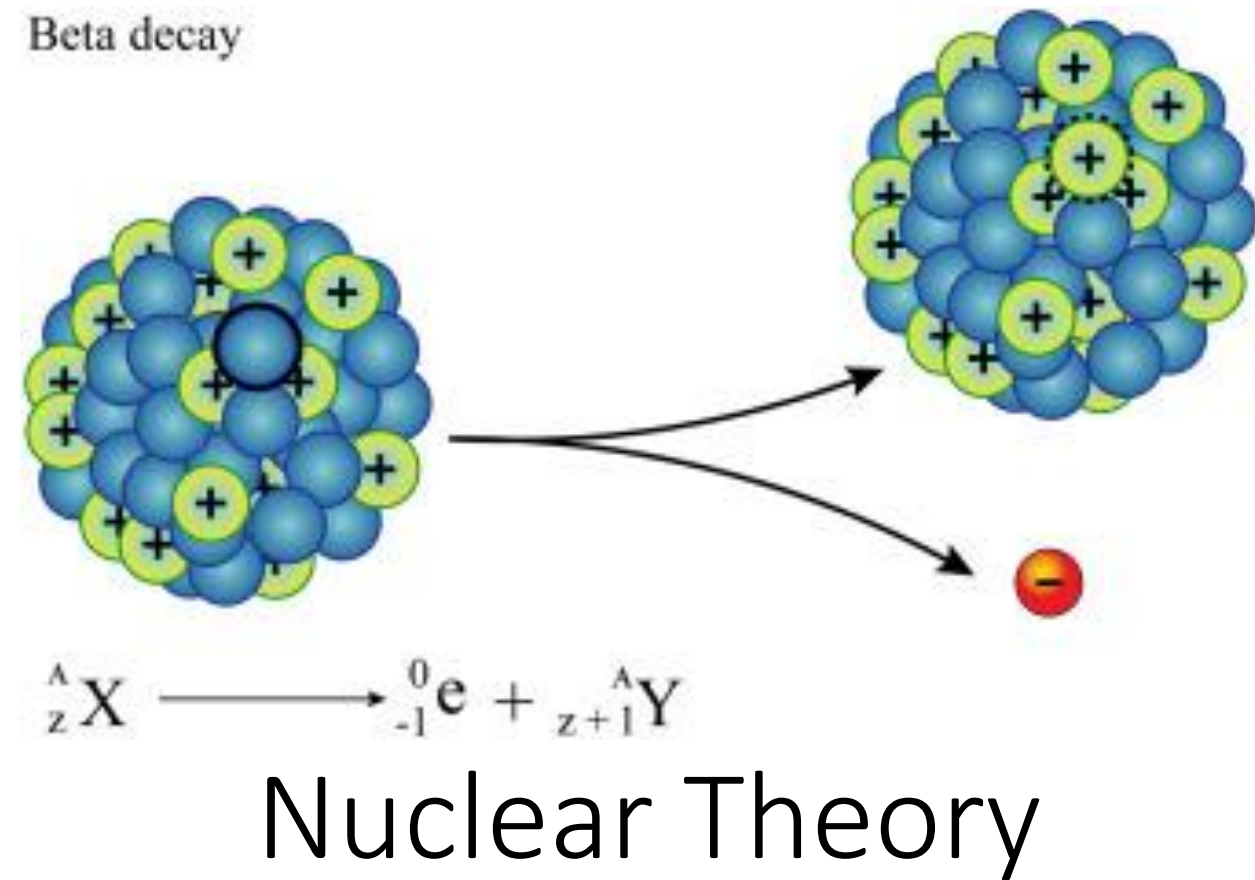

Long-lived isotopes that undergo electron capture

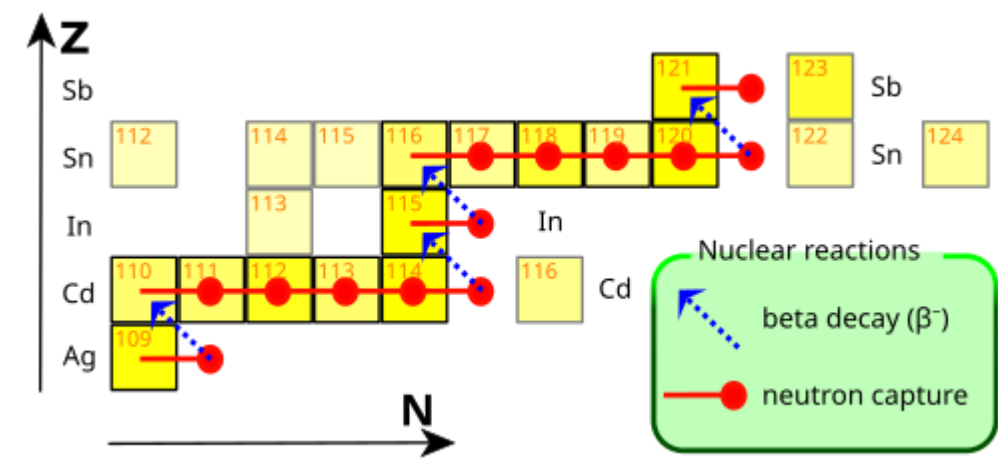

Astrophysics



Geochronology

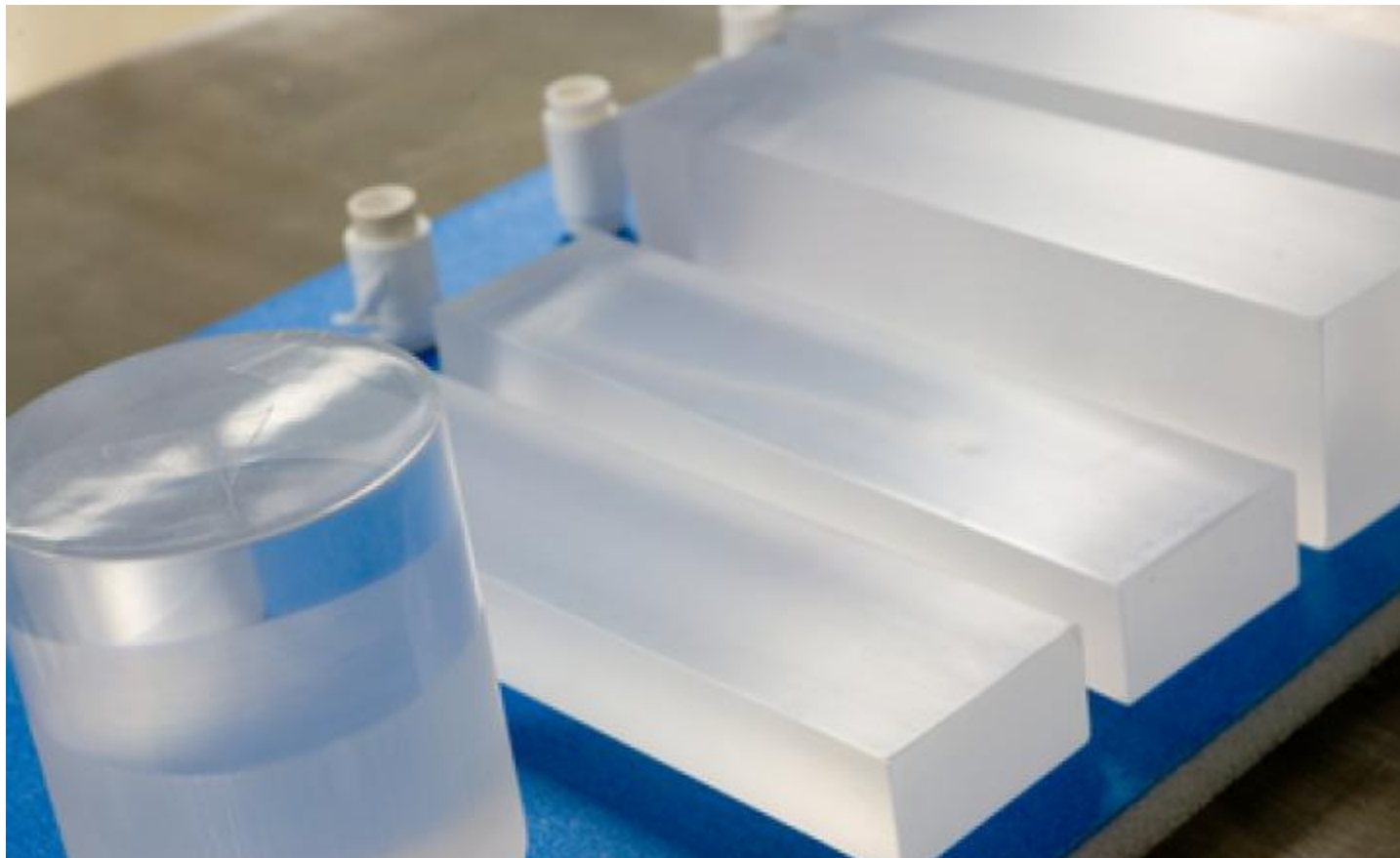

Backgrounds

β -decay

$$\Gamma \sim \frac{1}{\tau_{1/2}} \sim F_K g_a^2 |M_k|^2$$

$\beta\beta$ -decay



$$\Gamma \sim \frac{1}{\tau_{1/2}} \sim F_{\beta\beta} g_a^4 |M_k|^2$$

- F = phase space factor
- M = Nuclear matrix element
- g_v = weak vector strength (coupling)
- g_a = weak axial-vector strength (coupling)
- Conserved Vector Current (CVC) hypothesis $\underline{g_v = 1.0}$
- Partially Conserved axial-vector hypothesis $\underline{g_a = 1.27}$

Quenching of the weak axial-vector coupling strength

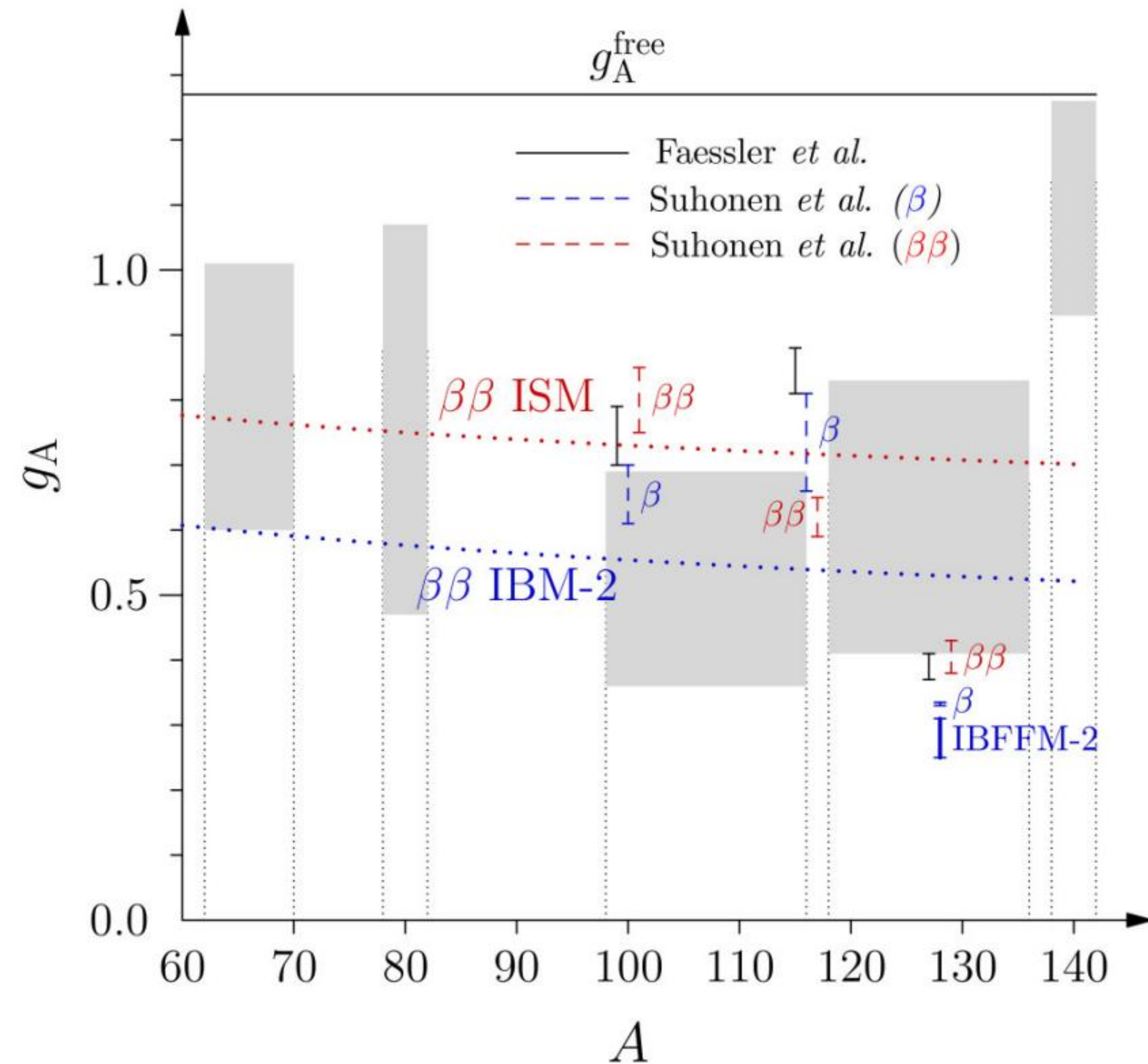

$$g_a^{eff} = q g_a^{free}$$

- Nuclear medium effects and nuclear many body effects cause a renormalization (higher or lower) of the weak-axial vector strength
 - Meson-exchange currents, interference from non-nucleonic degrees of freedom, deficiencies in the nuclear many-body approach etc....
- It is difficult to relate the quenching in β -decays vs. $\beta\beta$ -decays
- All theory, based calculations, which need experimental measurements to help verify

[Suhonen, J. T. \(2017\). Value of the axial-vector coupling strength in \$\beta\$ and \$\beta\beta\$ decays: A review. Frontiers in Physics, 5, 55.](#)

Ab-initio Measurements

Ab Initio Nuclear Theory for Neutrinoless Double-Beta Decay

Jun 23, 2026, 3:00 p.m.
15m
C408 (cap. 50) (U. Ottawa - Learning Crossroads (CRX) Building)

Speaker: Alex Todd (McGill University)

Oral Competition (Grad...)
Nuclear Physics / P...
(DNP) T2-6 Nuclear Th...

- Studied Gamow-Teller decays, where quenching should dominate
- Through many-body computation of nuclei based on effective field theories of quantum chromodynamic and by including unprecedented number of corrections in the nuclear wave functions, achieved a very strong match with data.
- This was done for medium mass isotopes. Does it hold for massive highly forbidden ones? **Need to measure**

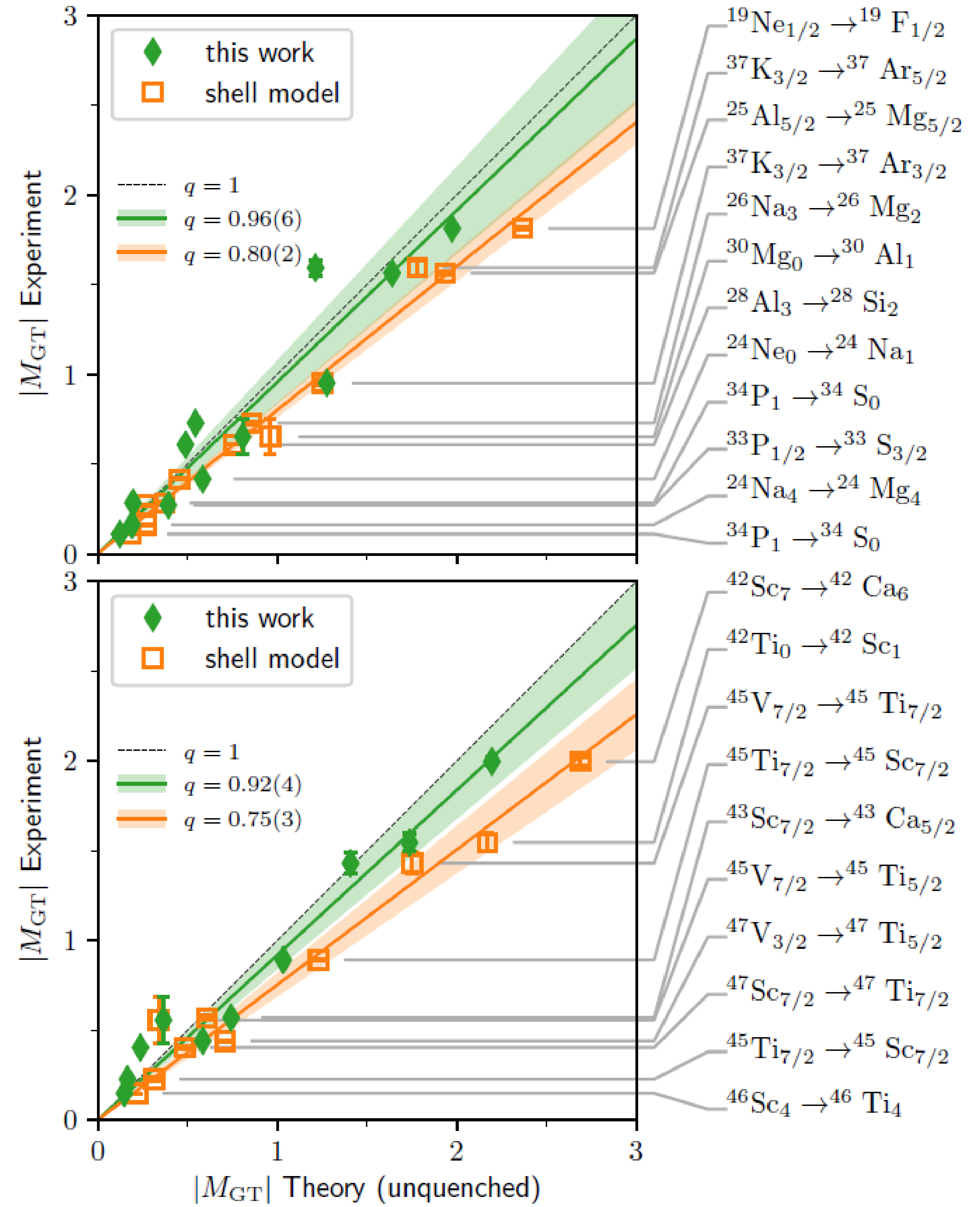

Gysbers, P., et al. (2019). Discrepancy between experimental and theoretical β -decay rates resolved from first principles. *Nature Physics*, 15(5), 428-431.

Experimental measurement of forbidden decays: KDK

M. Stukel,¹ L. Hariasz,¹ P.C.F. Di Stefano,^{1,*} B.C. Rasco,² K.P. Rykaczewski,² N.T. Brewer,^{2,3}
 D.W. Stracener,² Y. Liu,² Z. Gai,⁴ C. Rouleau,⁴ J. Carter,⁵ J. Kostensalo,⁶ J. Suhonen,⁷ H. Davis,^{8,9}
 E.D. Lukosi,^{8,9} K.C. Goetz,¹⁰ R.K. Grzywacz,^{2,3,11} M. Mancuso,¹² F. Petricca,¹² A. Fijałkowska,¹³
 M. Wolińska-Cichocka,^{2,3,14} J. Ninkovic,¹⁵ P. Lechner,¹⁵ R.B. Ickert,¹⁶ L.E. Morgan,¹⁷ P.R. Renne,^{5,18} and I. Yavin
 (KDK Collaboration)

KDK Experiment



Potassium

KDK

“Decay”

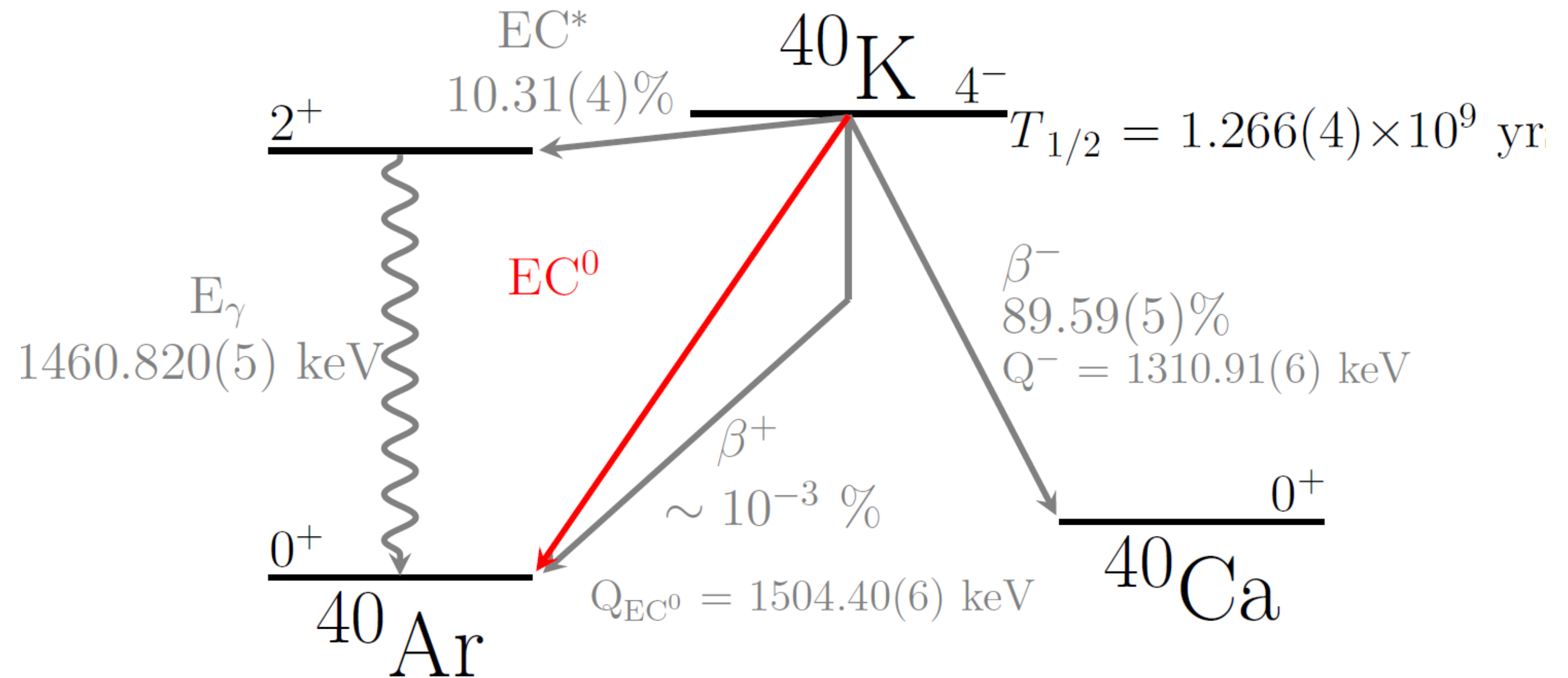

[KDK Collaboration. \(2023\). Rare K 40 Decay with Implications for Fundamental Physics and Geochronology. *Physical Review Letters*, 131\(5\), 052503.](#)

[KDK collaboration. \(2023\). Evidence for ground-state electron capture of K 40. *Physical Review C*, 108\(1\), 014327.](#)

- **Nuclear Theory**: Rare 3U EC transition
- **Particle Physics**: ^{40}K is a background in **rare-event searches**: especially in **NaI based detectors**
 - E.g. DAMA, COSINUS, COSINE-100, ANAIS-112 and PICO-LON
- **Geochronology**: $\sim 10^9$ years half-life, excellent for dating

KDK Experimental Setup

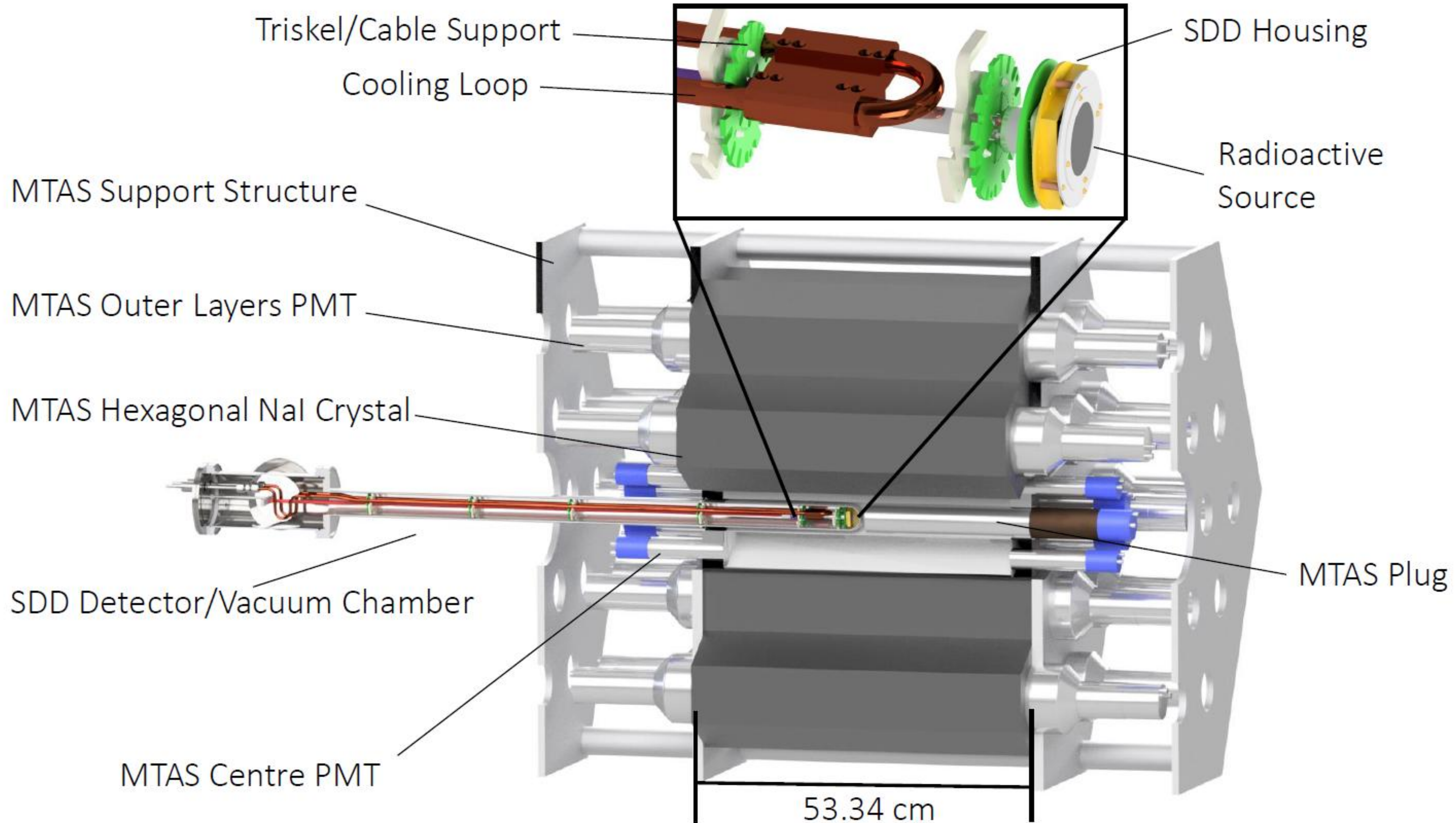

SDD – Silicon Drift Detector

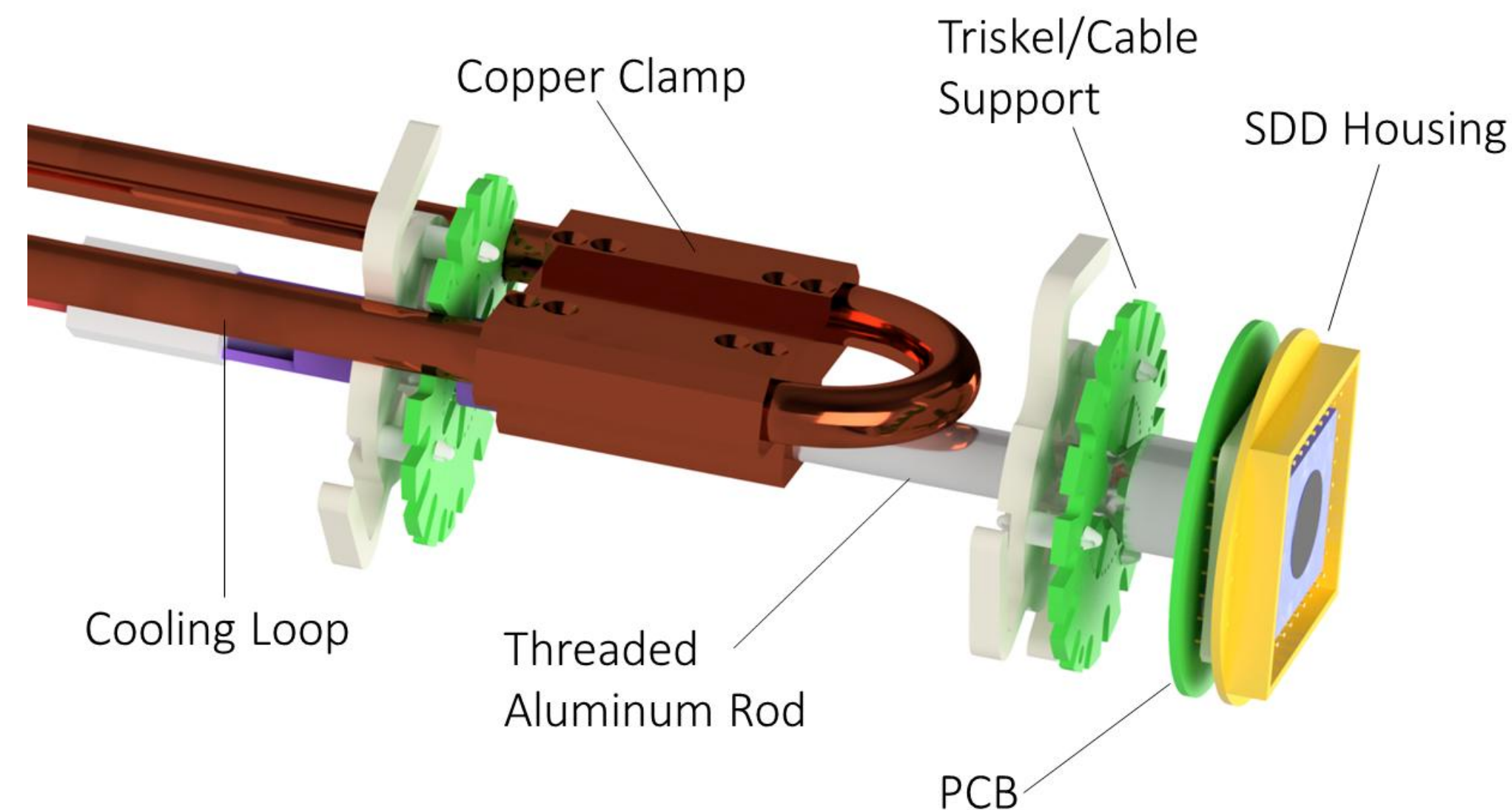
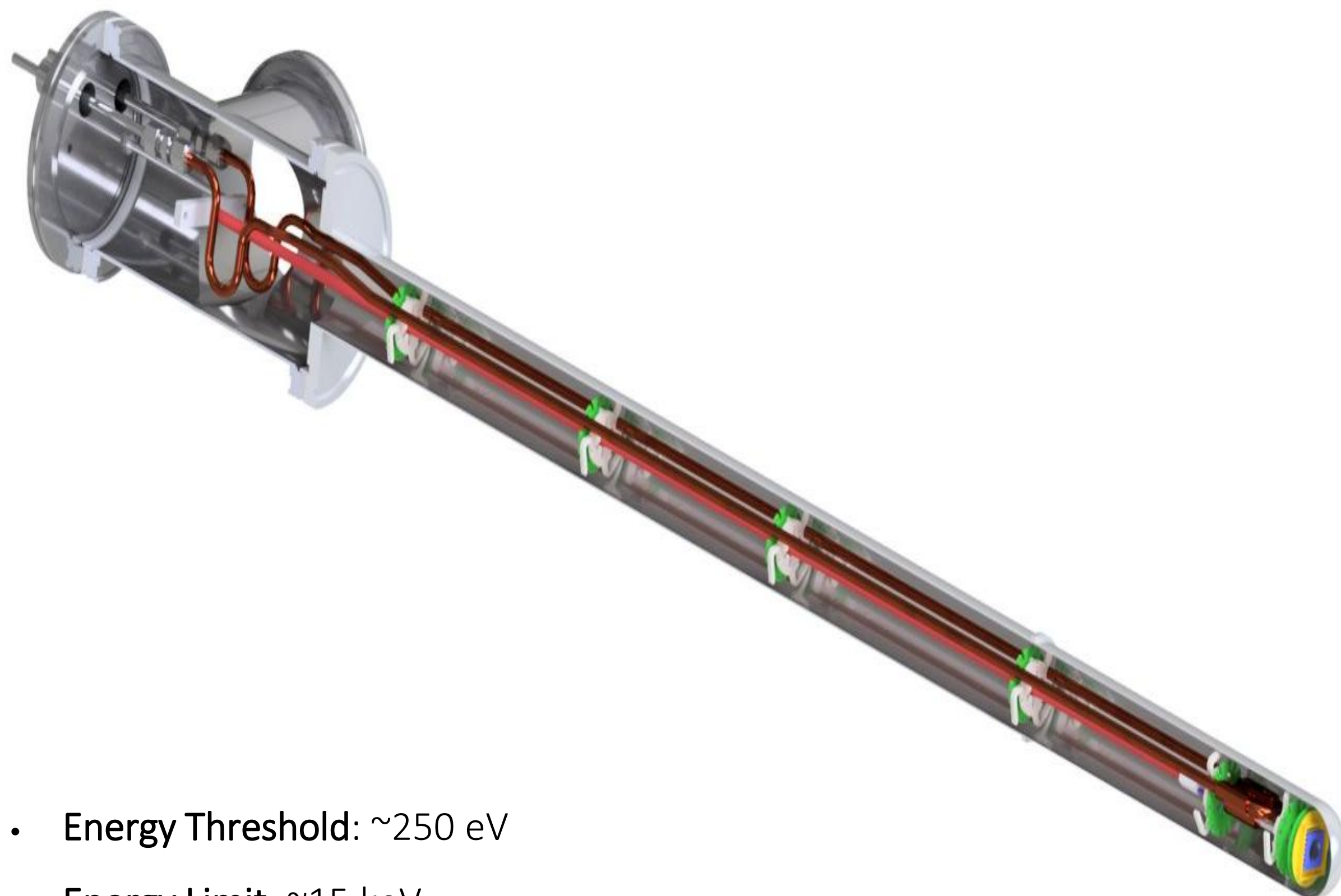

- Energy Threshold: ~ 250 eV
- Energy Limit: ~ 15 keV
- FWHM: ~ 170 eV @ 6keV

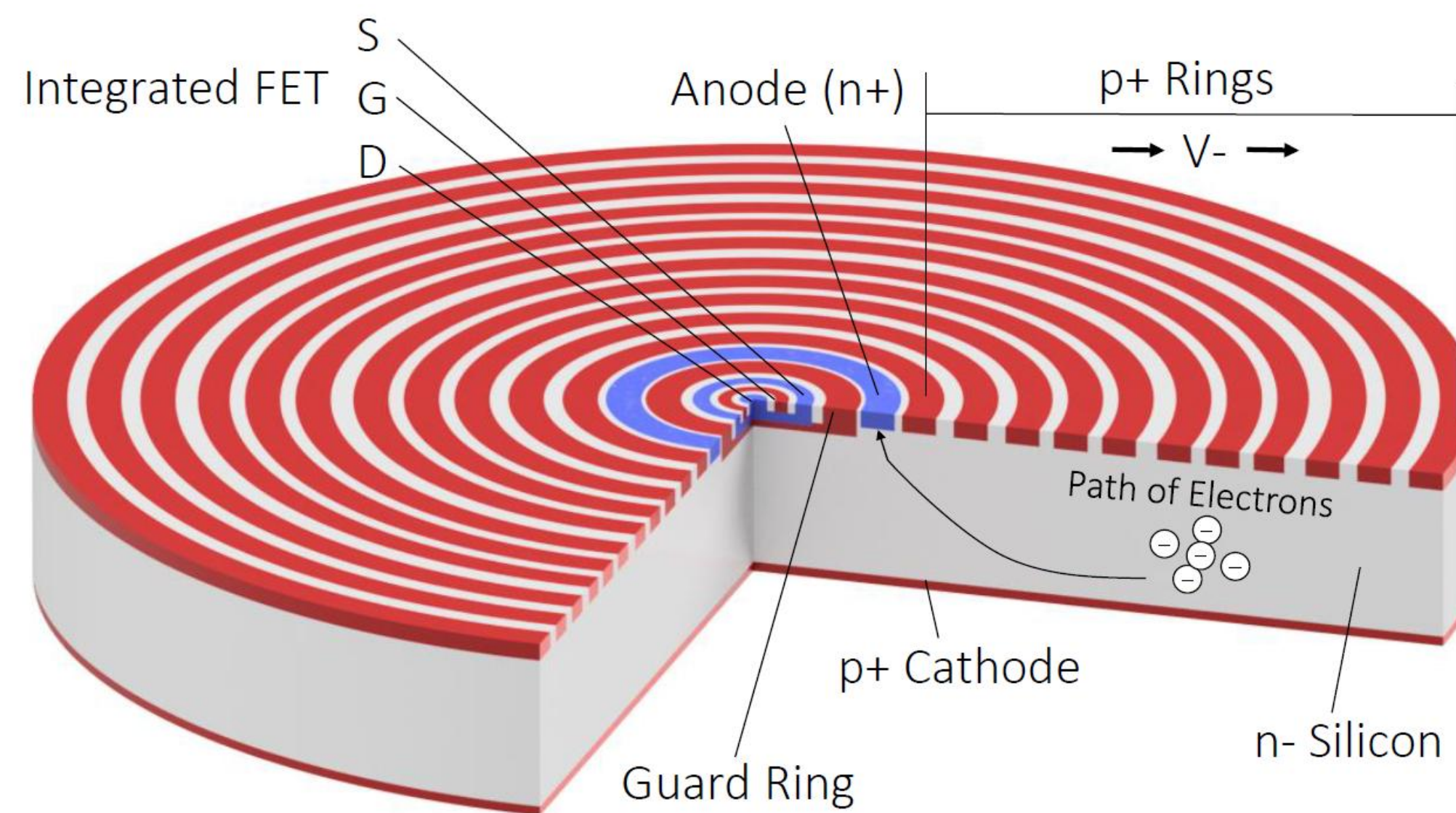

KDK Results

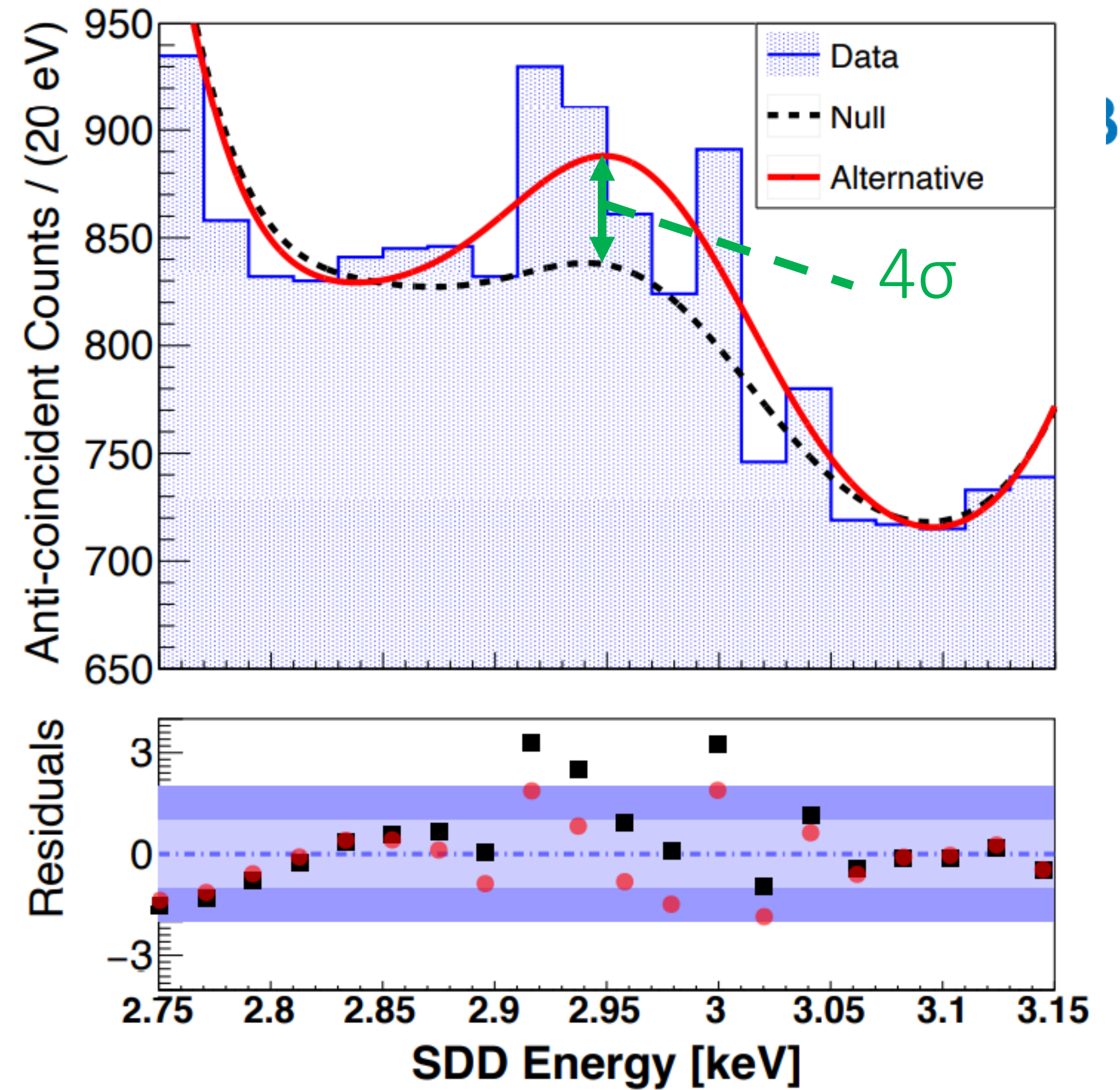
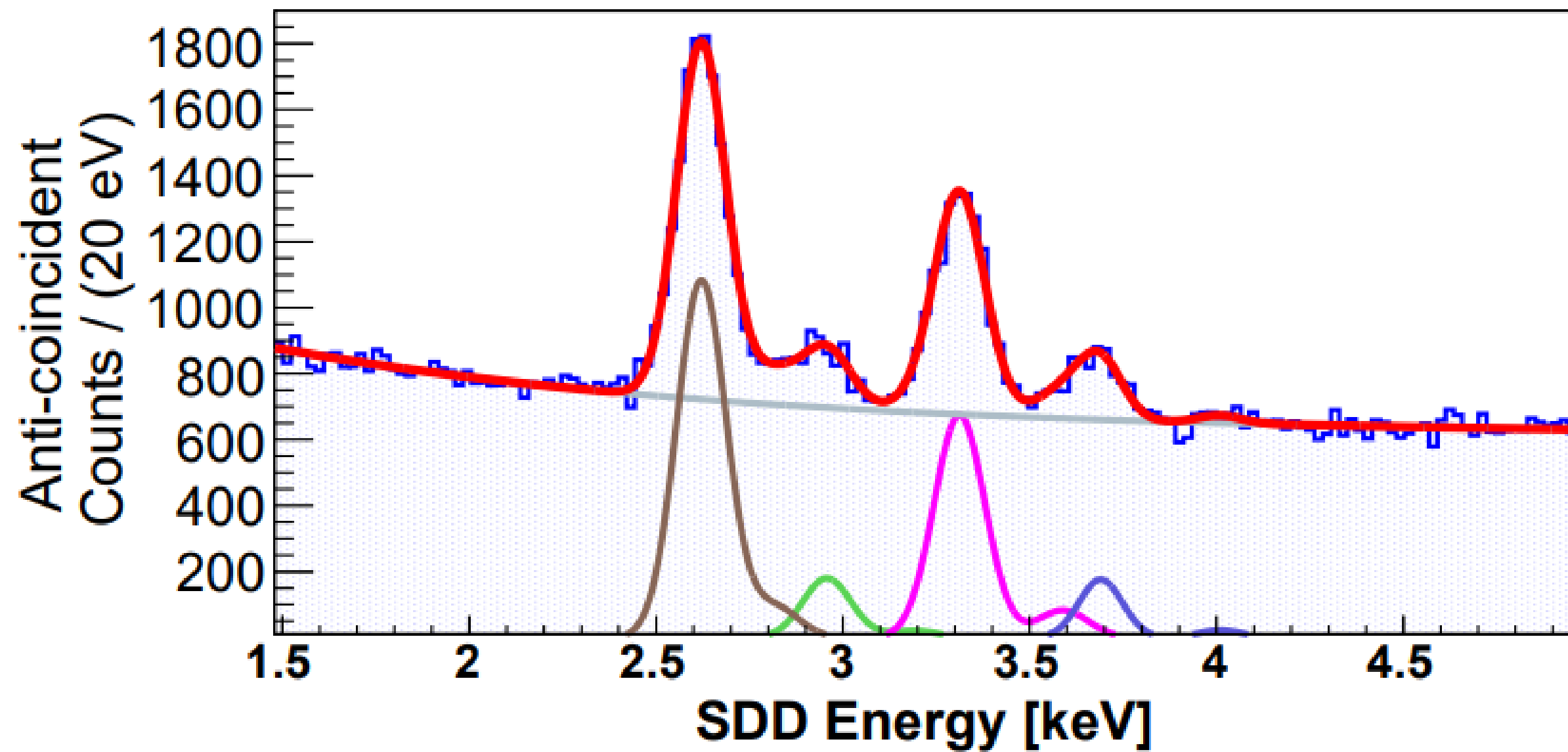
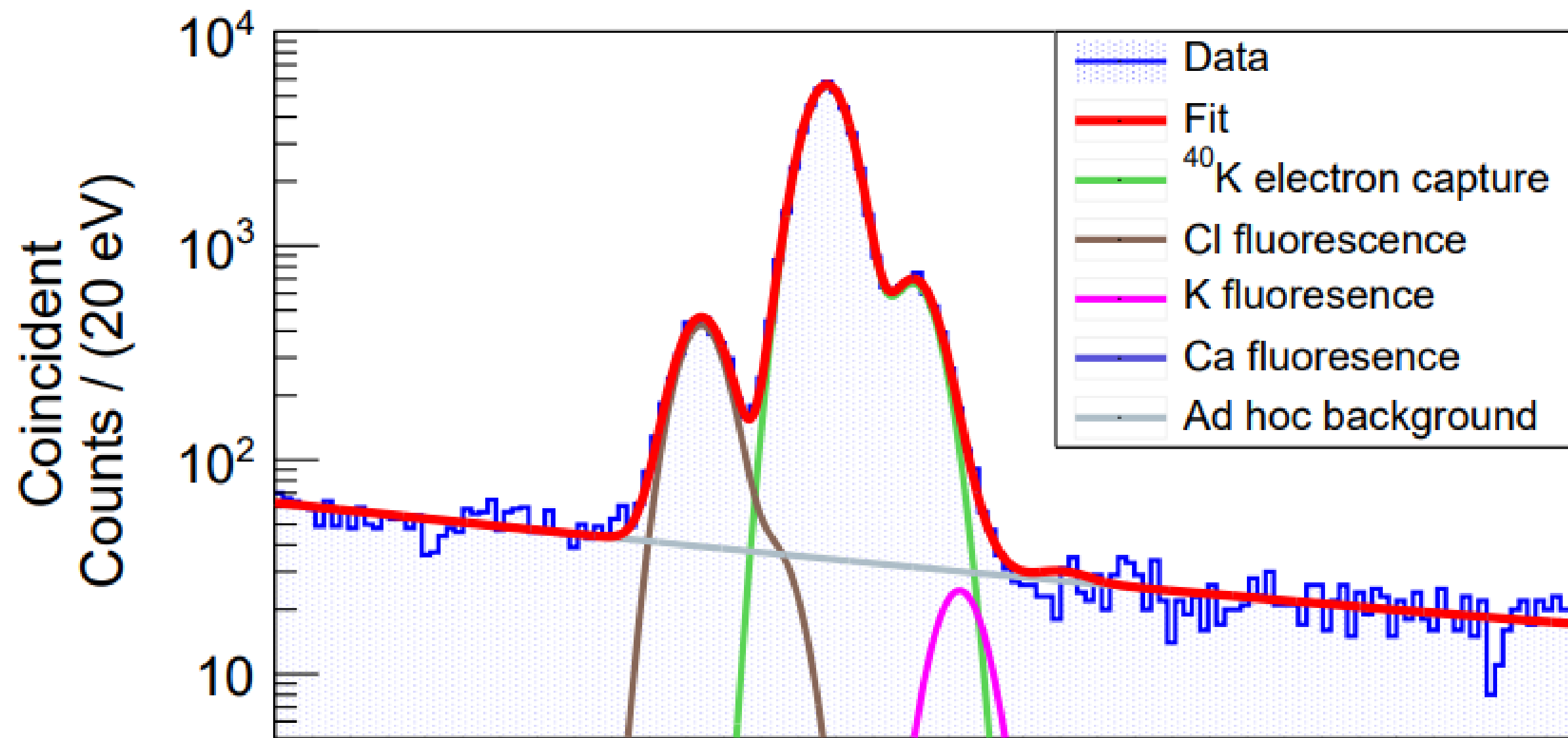

BREC = 0.098 +/- 0.023 (stat) +/- 0.01 (syst) %

VIEWPOINT

PDF Version



Measuring Decays with Rock Dating Implications

Stephen Ellis Cox

Lamont-Doherty Earth Observatory, Columbia University, Palisades, NY, US

July 31, 2023 • *Physics* 16, 131

Researchers revisit a neglected decay mode with implications for fundamental physics and for dating some of the oldest rocks on Earth and in the Solar System.

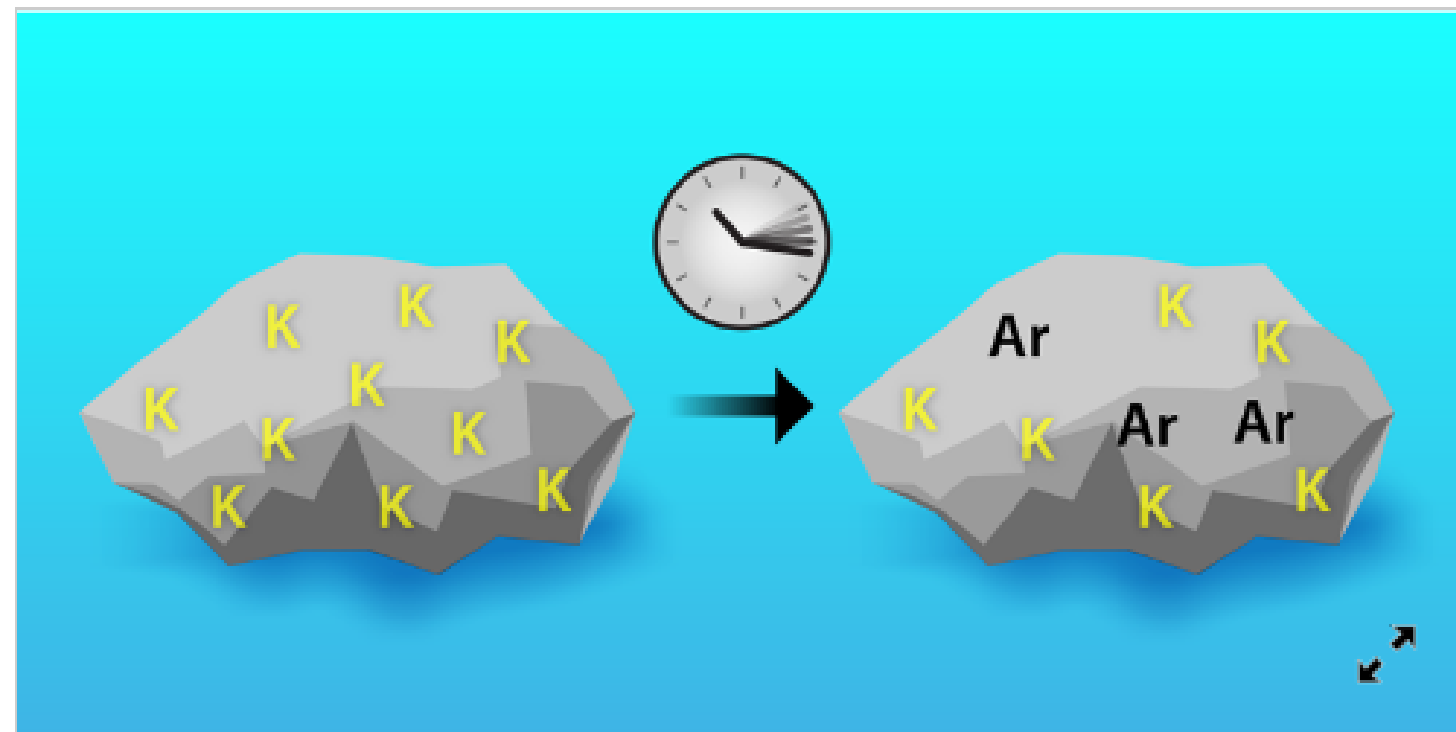

APS/Alan Stonebraker

Figure 1: As a rock forms, it traps a set of potassium-40 within the solid. Decays of this isotope produce argon-40. By measuring the amount of argon-40 relative to that of potassium-40, geologists can date the rock.

Rare ^{40}K Decay with Implications for Fundamental Physics and Geochronology
 M. Stukel *et al.* (KDK Collaboration)
 Phys. Rev. Lett. 131, 052503 (2023)
 Published July 31, 2023

Read PDF

Evidence for ground-state electron capture of ^{40}K
 L. Hariasz *et al.* (KDK Collaboration)
 Phys. Rev. C 108, 014327 (2023)
 Published July 31, 2023

Read PDF

Recent Articles

How Metal Meteorites Magnetize

For a metal meteorite to retain a magnetic field, its parent asteroid may need a cold rubble core to help drive an internal dynamo.

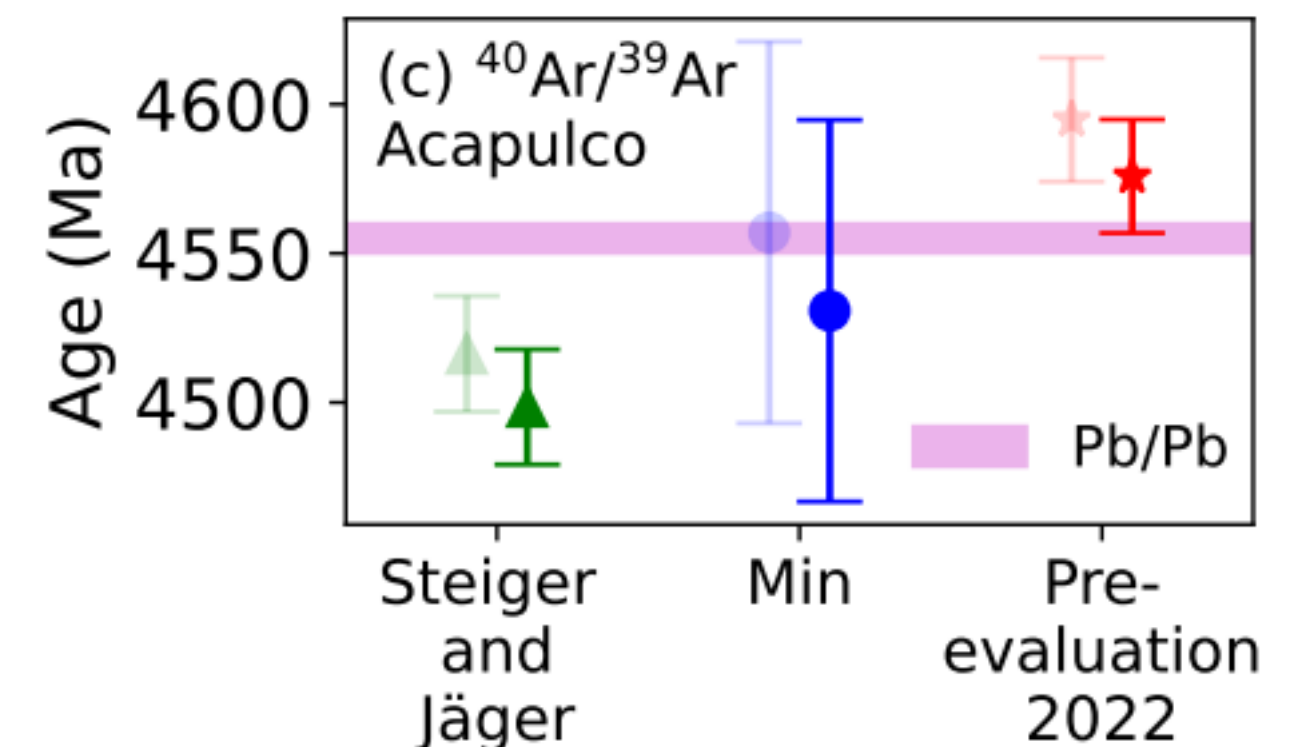
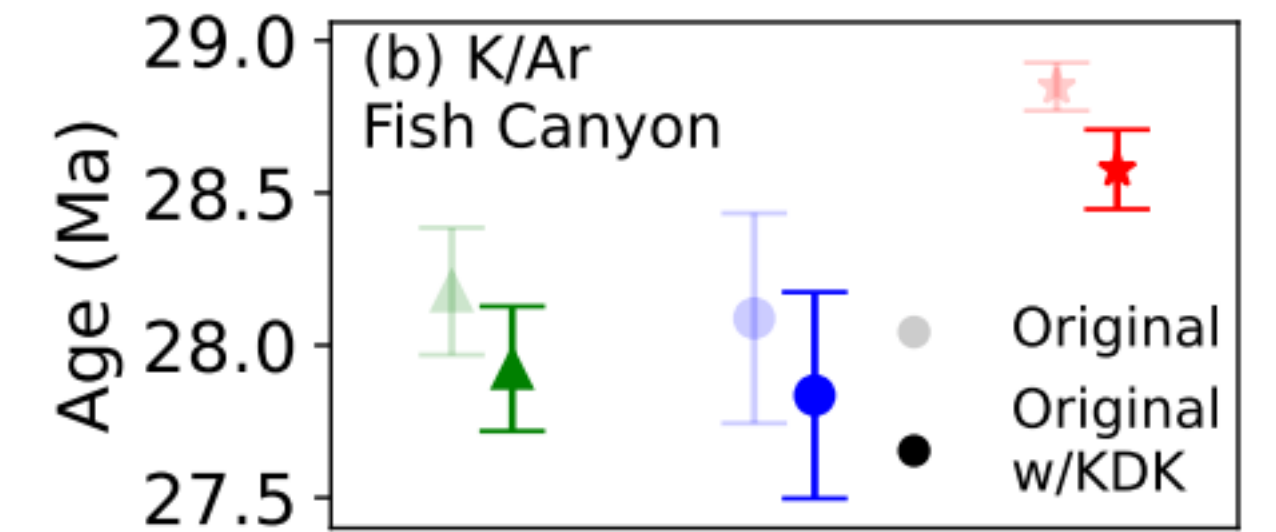
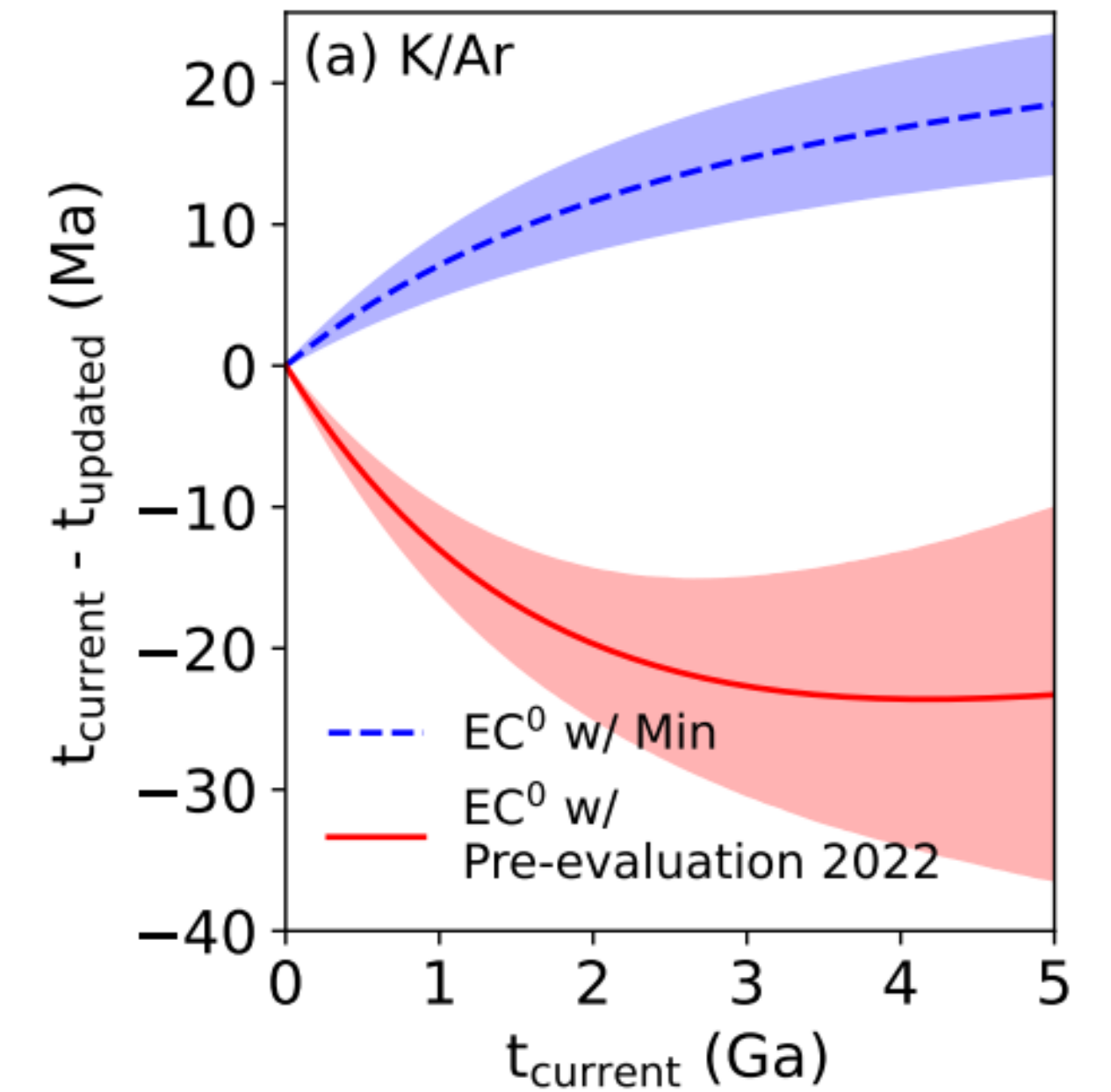

Link: <https://physics.aps.org/articles/v16/131>

- Particle Physics:

- Quantified a previously unknown low energy background present in many dark matter experiments
- Because measured BR value was lower than the commonly used value this relaxes the modulation fraction constraint placed on the DAMA/LIBRA experiment

- Nuclear Physics

- First measurement of a third-forbidden unique electron capture transition

- Geochronology

- Traditional K/Ar ages have been overestimated by not including the ground state decay
 - This is dependent on the decay evaluation chosen
- Ar-Ar dating is indirectly affected as this method requires the use of K-Ar dated calibration sources

Experimental measurement of forbidden decays: KDK^+

KDK+ Collaboration

Collaborators:

CNL: T. Domingo, A. Erlandson, K. Hartling, D. Pérez-Loureiro, **BNL:** M. Yeh,
SNOLAB: M. Stukel, **ORNL:** C. Rasco, K. Rykaczewski, **SFU:** L. Hariasz,
Queen's: R. Arsenne, G. Croft, Y. Coudiere, P. Di Stefano, L. Hummel, A. Lemaire,
L. Lopez-Proville, N. Swidinsky, P. Gros, N. Panchal, G. Savvidis

KDK+ Experiment



Potassium

KDK +
Decay

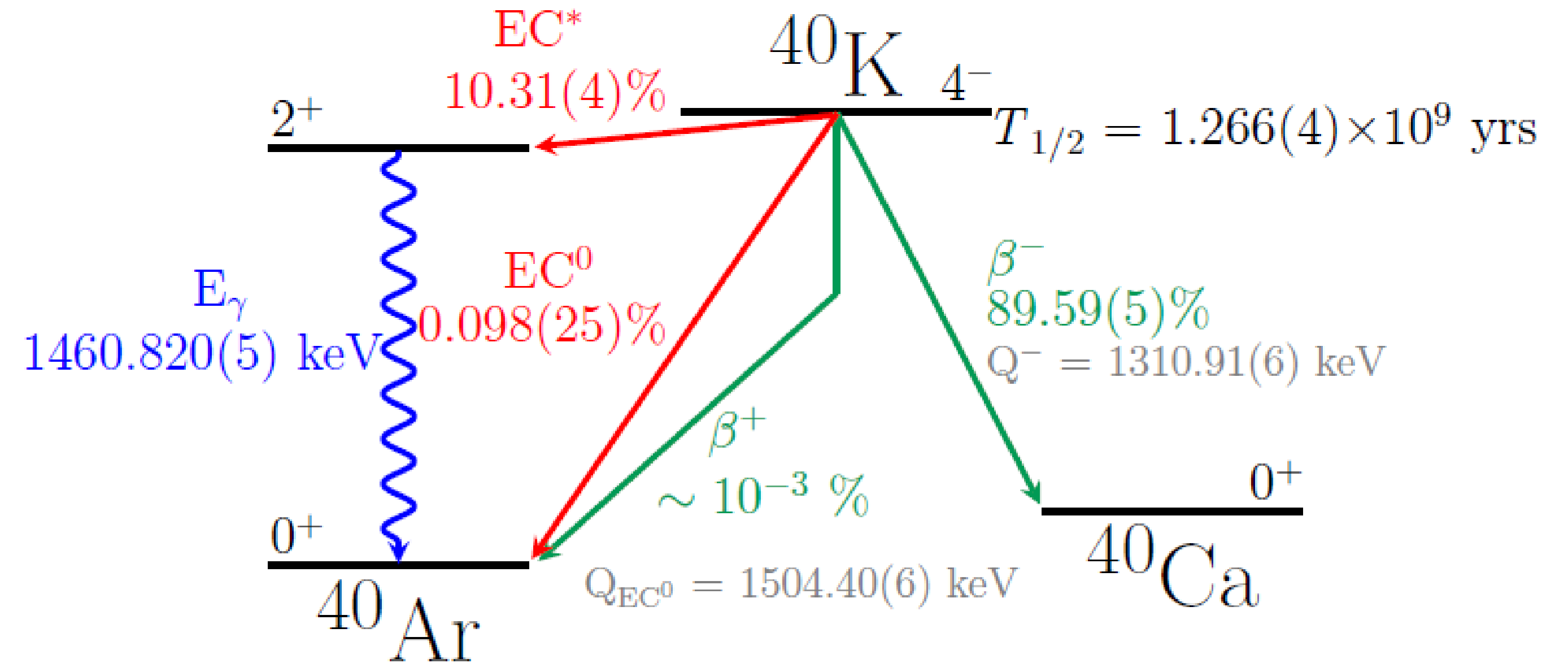

- KDK+ is a follow-up to the KDK experiment and is looking for the β^+ decay of ^{40}K
- Previous experimental measurements provide inconsistent results for the decay rate of this channel

KDK+ Experimental Setup

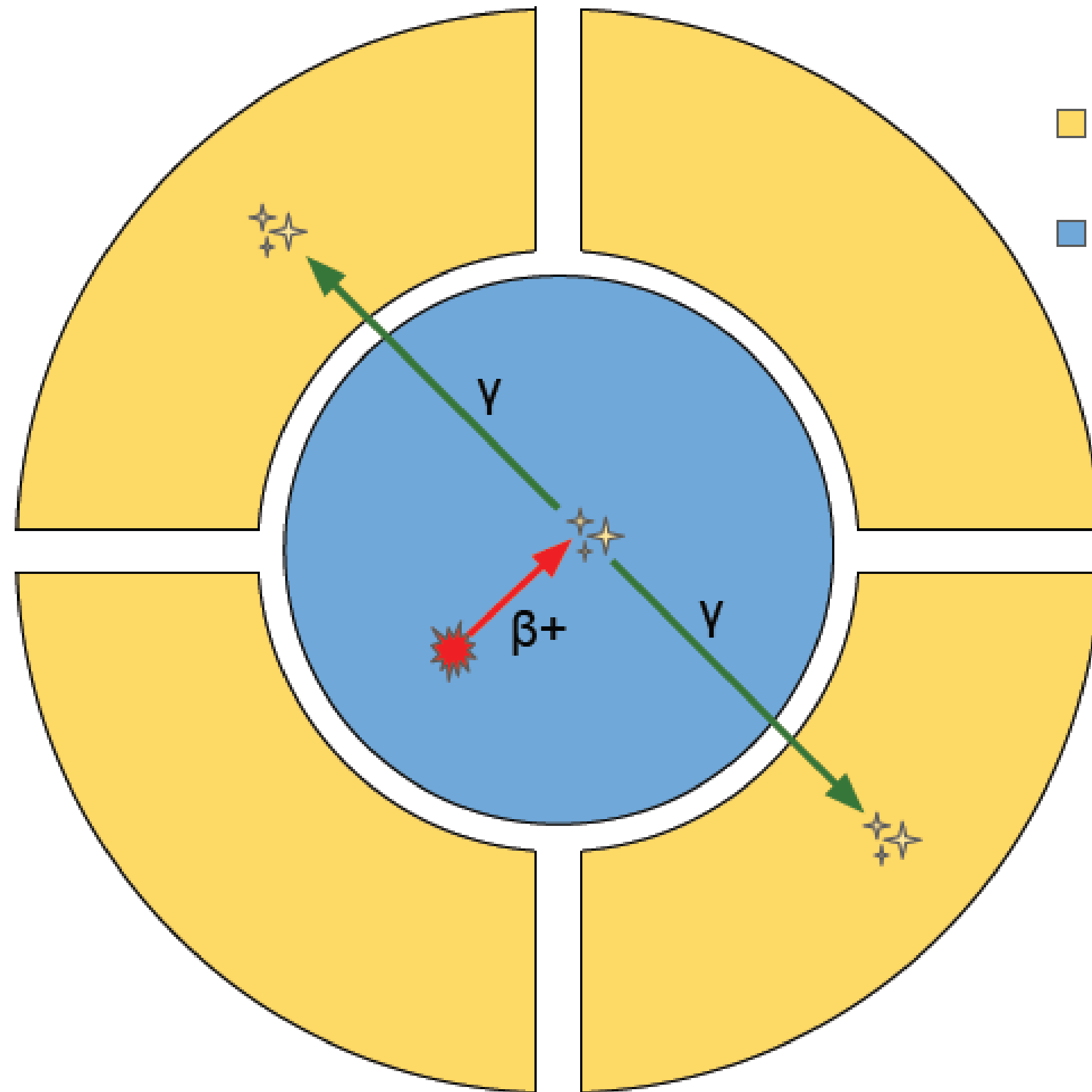

- NaI
- Liquid Scintillator

Systematics and Calibration for the KDK+ experiment

Jun 23, 2026, 11:15 a.m.

15m

C408 (cap. 50) (U. Ottawa - Learning Crossroads (CRX) Building)

Oral Competition (Grad...

Particle Physics / P...

(PPD) T1-11 Colliders | ...

Speaker

Cameron Ingo (Queen's)

- KDK+ will measure the β^+ decay by using a triple coincidence setup
- Source w/ liquid scintillator and segmented NaI γ -detector (MTAS or other)
- Liquid Scintillators Being Considered:
 - Ultima-Gold, LAB, Loaded plastic Scintillators, + more
- β^+ Activity (Natural Potassium): 0.1635 mBq/g
 - ~24 days of runtime needed to get 1000 β^+ events

SDD2 (to be renamed)

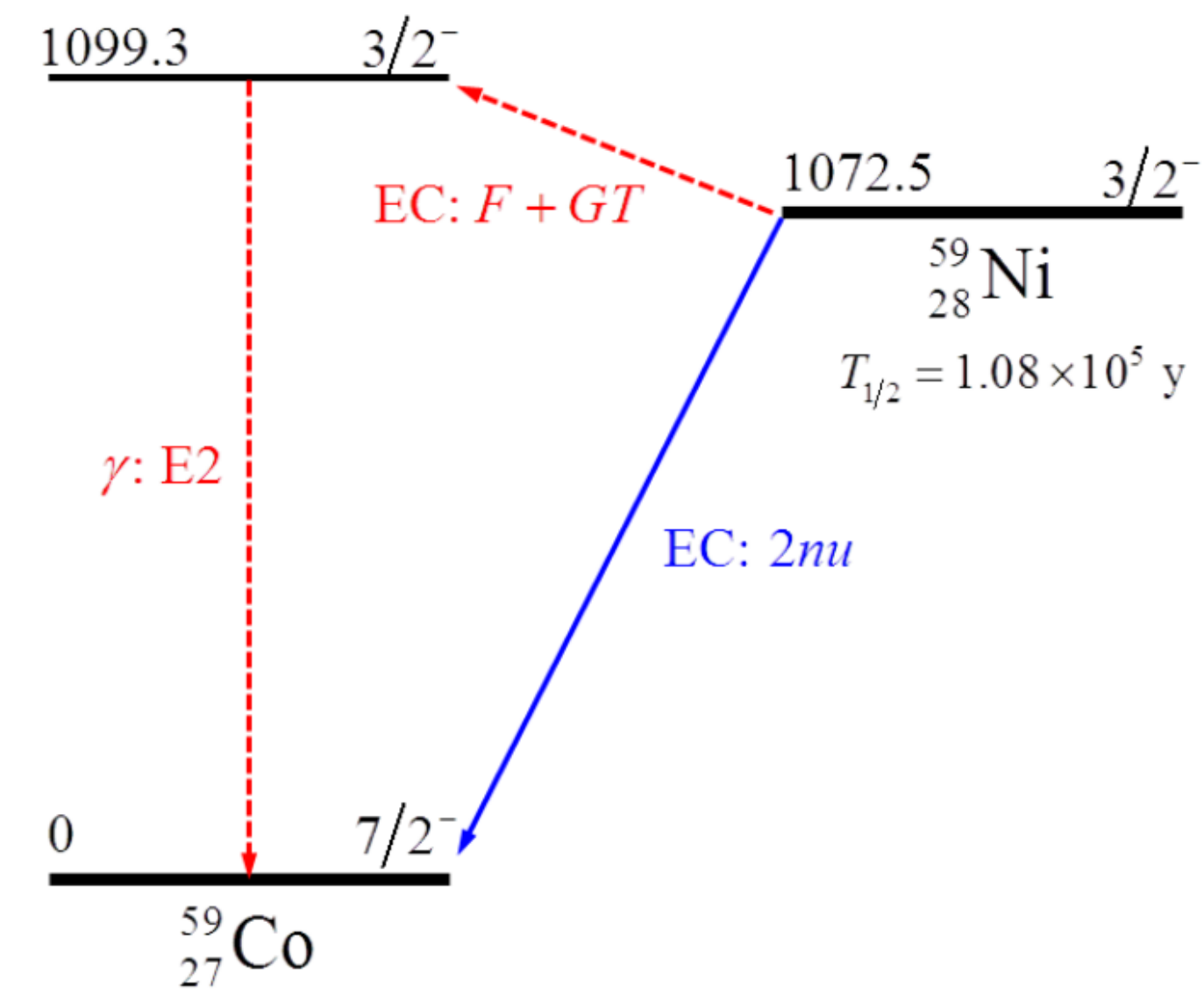
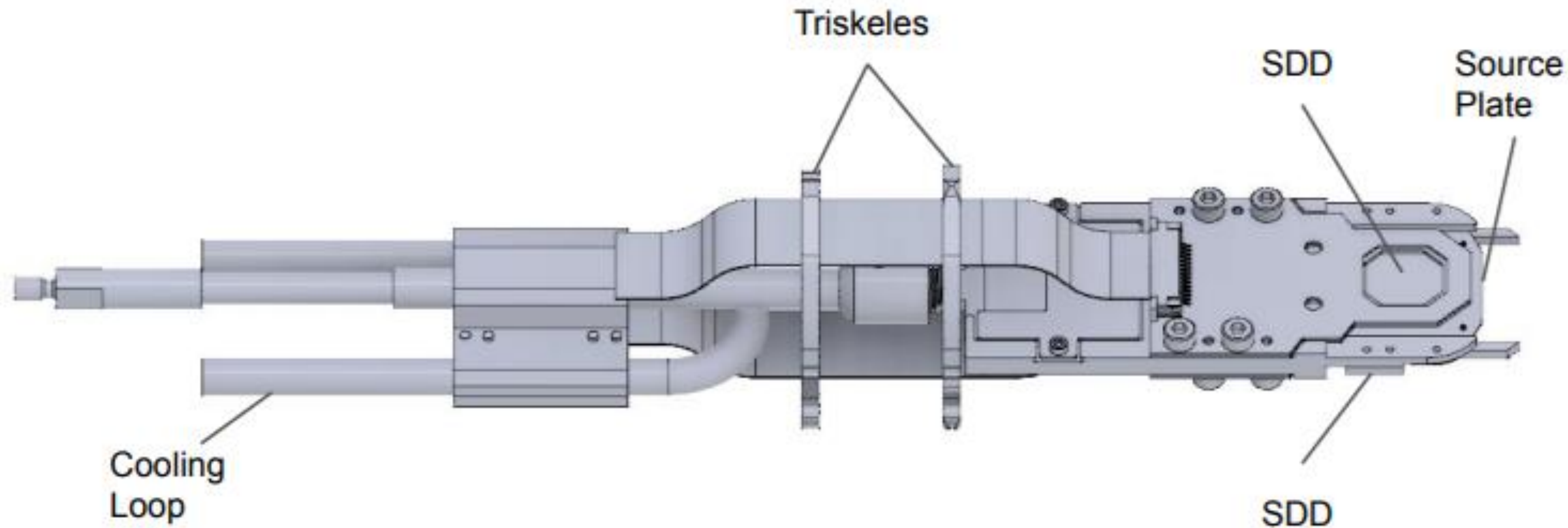

- SDD2 will utilize similar technology that was used in the KDK experiment but take advantage of the improved designs
- Replaceable source plate allow easy changeable sources, also cooled with LN to improve resolution with lower operating temperature
- Two SDD allow for close to 4π coverage
- ^{59}Ni : Testing radiative electron capture models and verifying measurements of virtual β - γ decays

Experimental measurement of forbidden decays: RAMPS

RAMPS Collaboration:

Matthew Stukel, Ian Lawson, Steffon Luoma, Diba Toyserkani, Sanjit Patel, Hector Hawley
Herrera

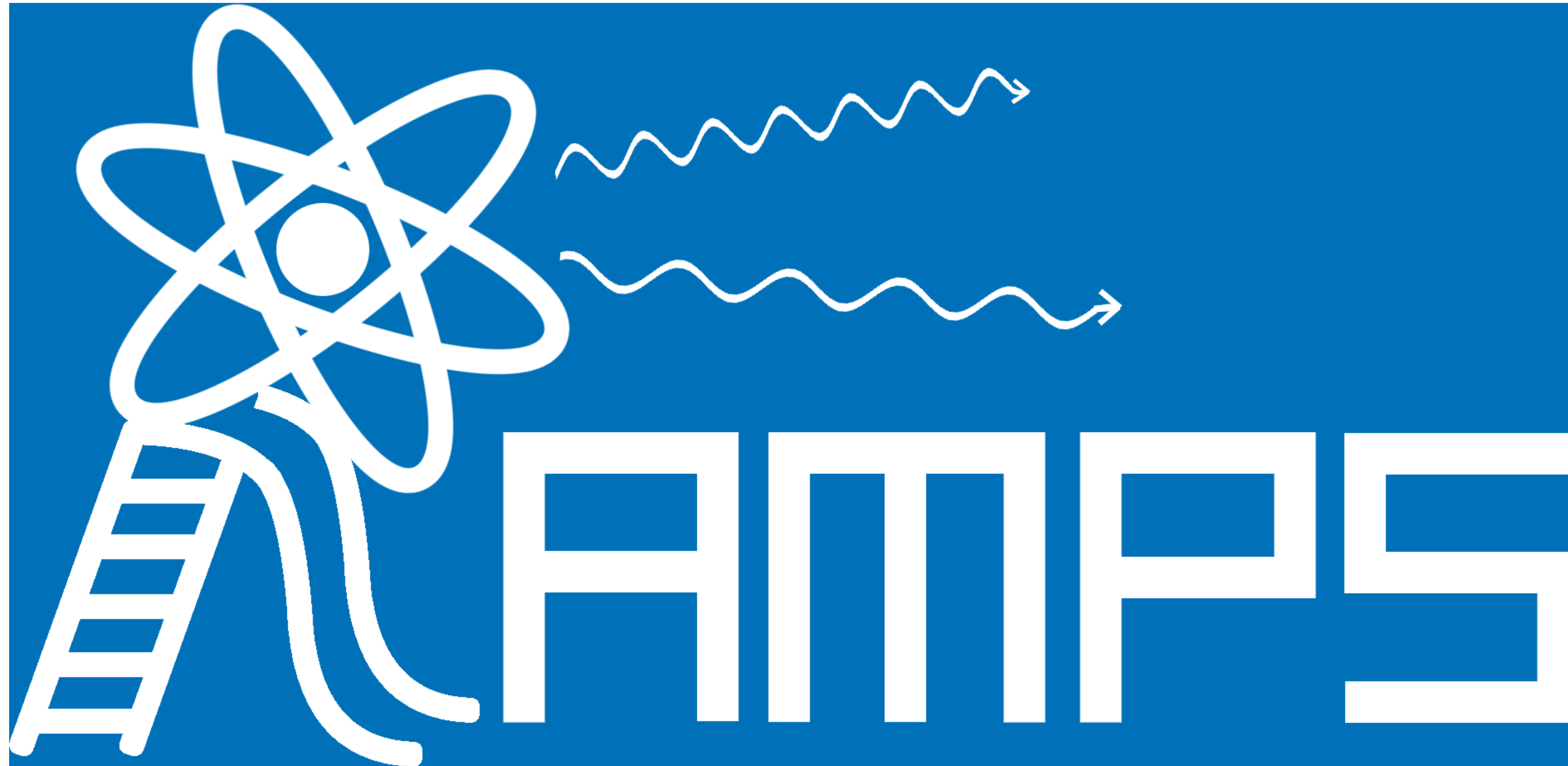

(RadioActive isotope Measurement Program at SNOLAB)

- **GOAL:** Perform novel, precision or standardization measurement of long-lived (highly forbidden) isotopes using or enhancing existing equipment at SNOLAB

SNOLAB



2070m (6000m w.e.)
~ 63 cosmic muons/day

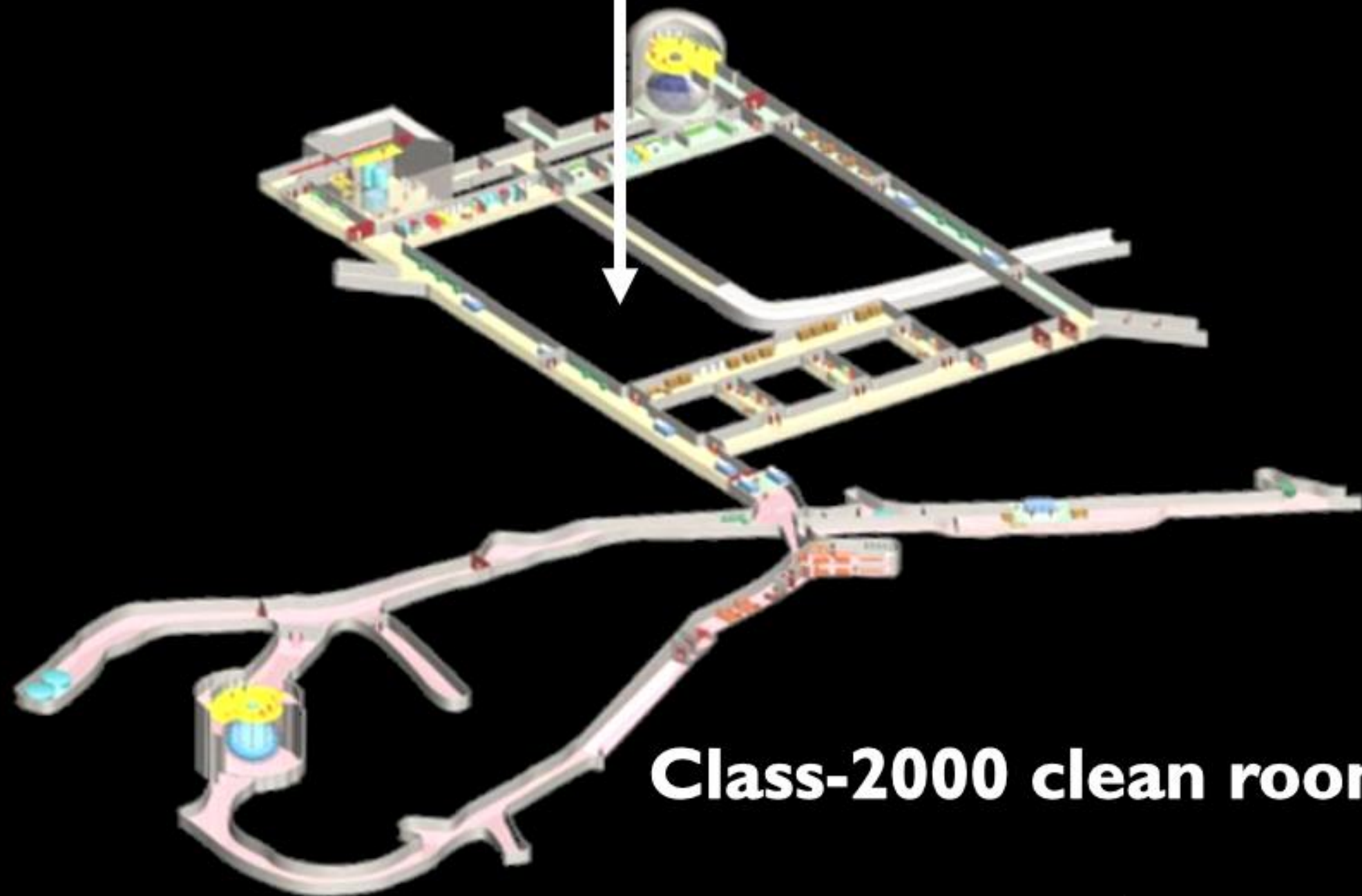

Class-2000 clean room



Low Background techniques at SNOLAB



PGT

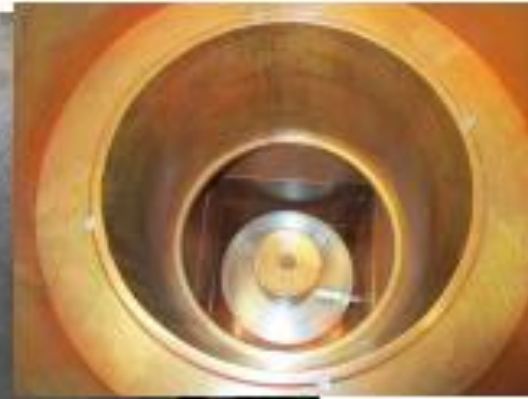

Lively

- Ge Spectrometry: 10-100 $\mu\text{Bq/kg}$
- Rn Emanation: 0.1-10 $\mu\text{BQ/kg}$
- ICP-MS: 1-100 $\mu\text{Bq/kg}$
- Environment & Waste Technologies Branch at CNL



WELL



Gopher



VDA

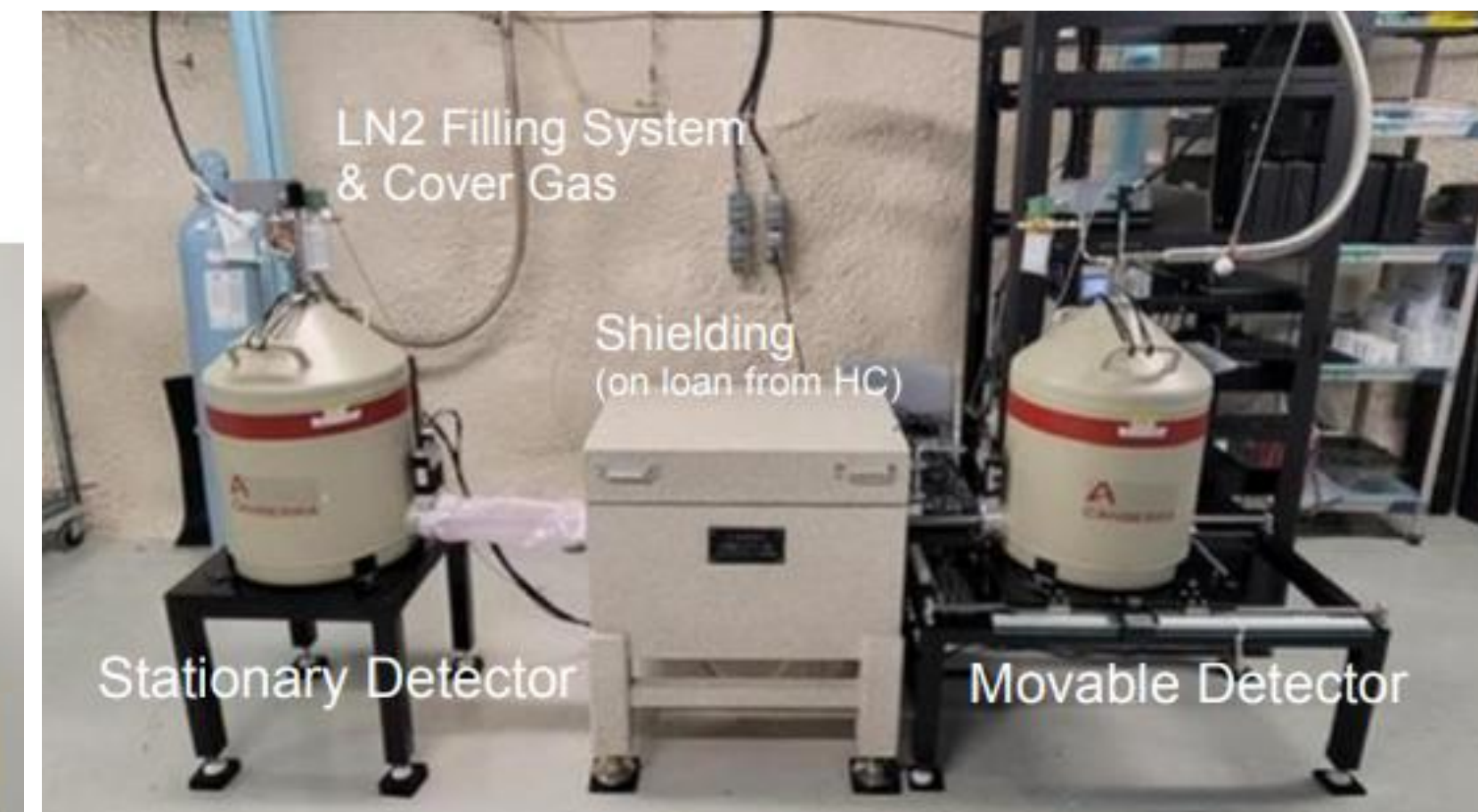

Rare-nuclear decays underground



Rare nuclear processes in Hf isotopes

<http://dx.doi.org/10.1142/S2010194523610062>

Investigation of rare nuclear decays with BaF₂ crystal scintillator contaminated by radium

<https://link.springer.com/article/10.1140/epja/i2014-14134-6>

A new investigation of half-lives for the decay modes of ⁵⁰V

<https://journals.aps.org/prc/abstract/10.1103/PhysRevC.99.045501>

Deep-underground search for the decay of ^{180m}Ta with an ultra-low-background HPGe detector

<https://doi.org/10.1140/epic/s10052-023-12087-5>

Electron spectral shape of the third-forbidden β -decay of ⁸⁷Rb measured using a Rb₂ZrCl₆ crystal scintillator

<https://doi.org/10.1140/epja/s10050-025-01780-6>



STELLA Facility Gran Sasso

Measurement of EC ^{176}Lu

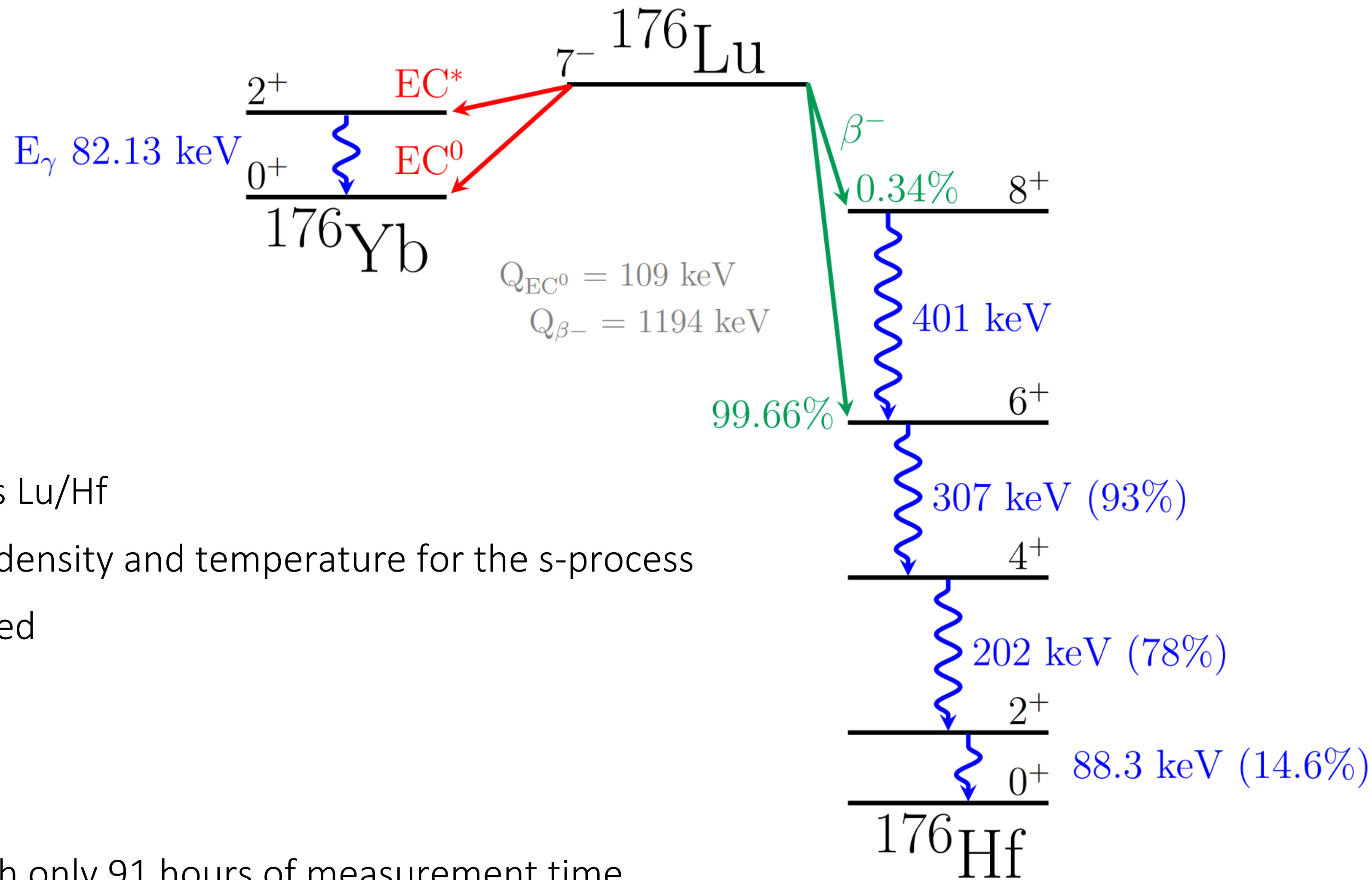

- Useful for understanding nuclear theory:
- ^{176}Lu : Used to date meteorites and minerals Lu/Hf
- ^{176}Lu can provide estimates of the neutron density and temperature for the s-process
- EC* has never been experimentally measured
- Only predicted
 - 2⁺: $10^{19} - 10^{21}$ yrs
 - 0⁺: $10^{25} - 10^{27}$ yrs
- Current half-life limit ($>10^{14}$ yrs) was set with only 91 hours of measurement time, background limited due to not being underground

Understanding the Spectrum of ^{176}Lu

- If measured on a pure HPGe primary background is β^- decay.
- Significantly limits the sensitivity
- Need a way to remove it!
- Lucky!!!!
- EC Q-value = 109 keV
- With gamma at 82 keV means only 27 keV available for the electron capture
- K-shell capture is not possible!
- Coincidence technique: SiPM + HPGe

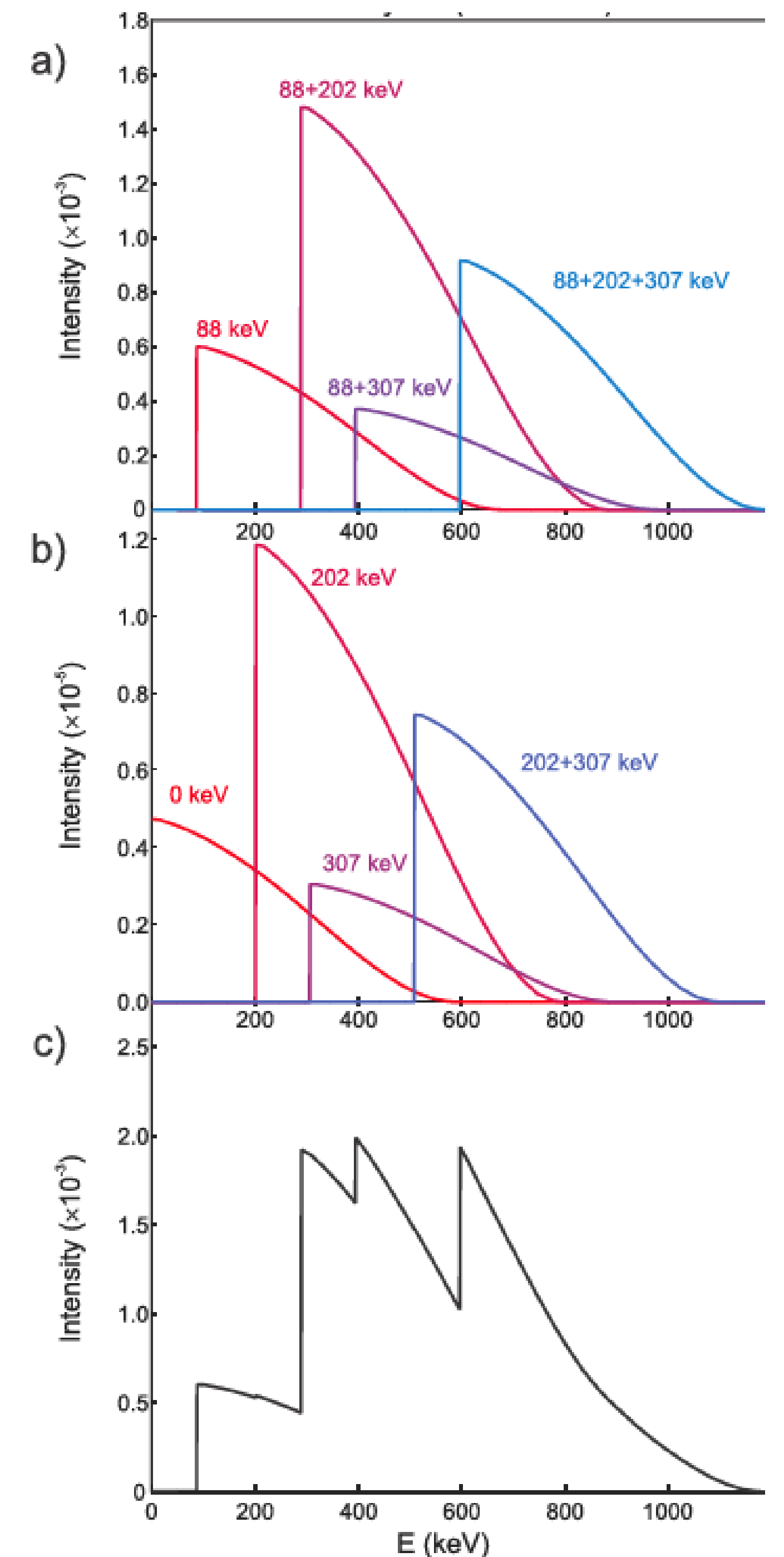

Experimental Design

HPGe

SiPM + LYSO Crystal

Light (0- 800 keV)

β^- Event

Gamma (88, 202 or/and 307 keV)

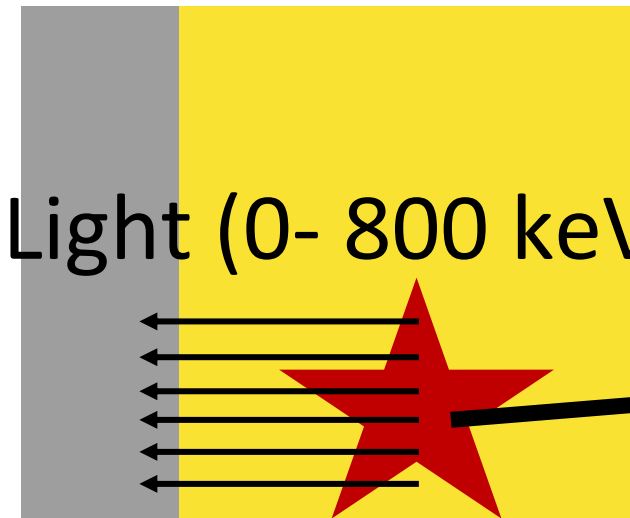

Light (0- 27 keV)

EC* Event

Gamma (82 keV)

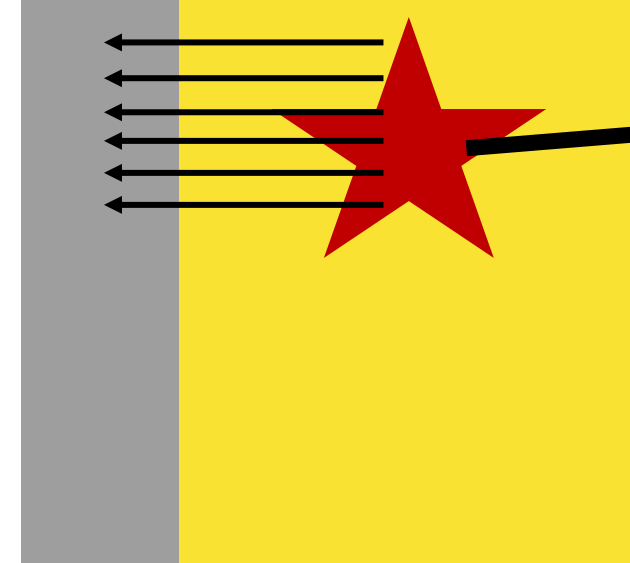

RAMPS: Experimental Technique

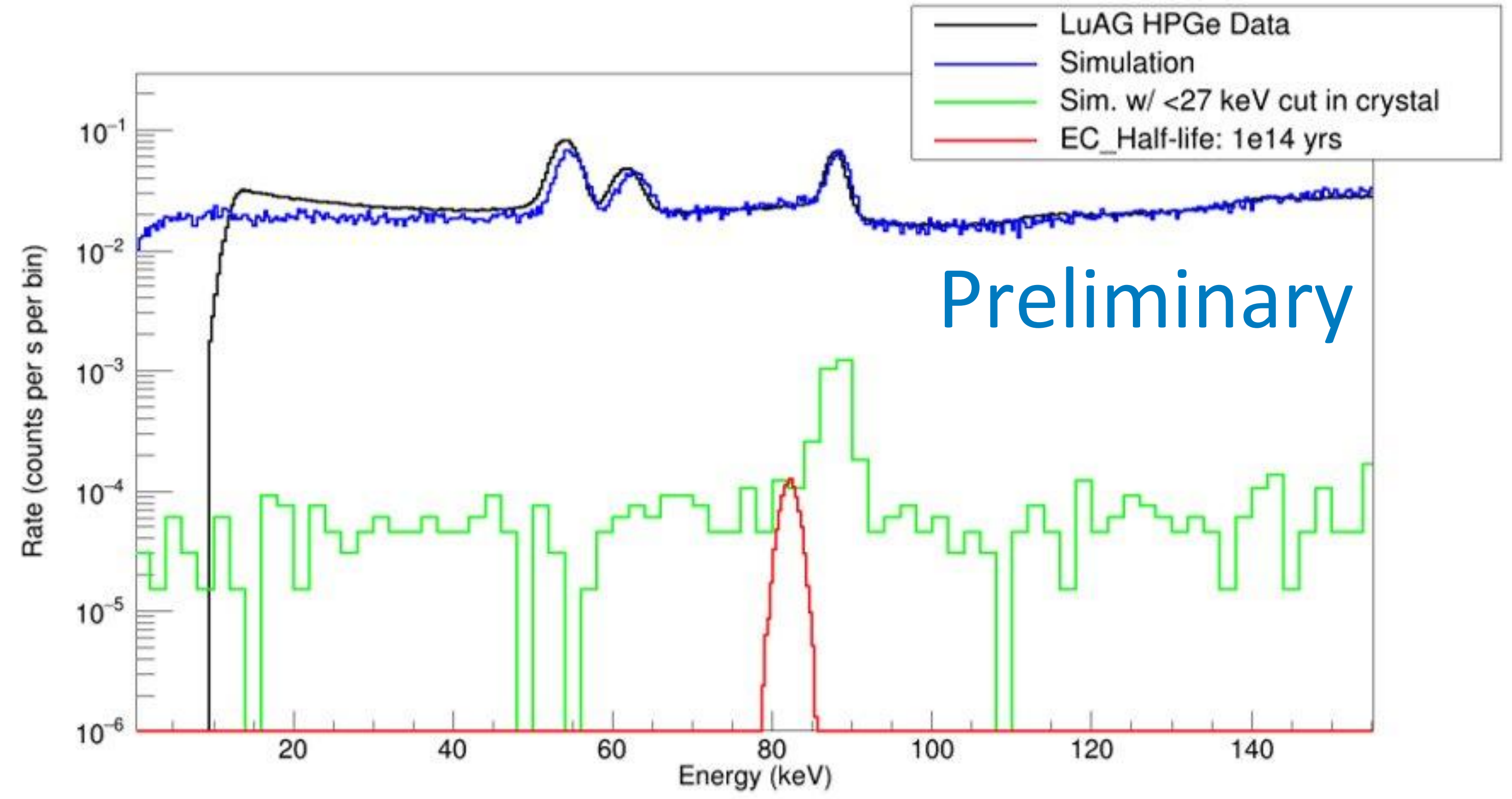
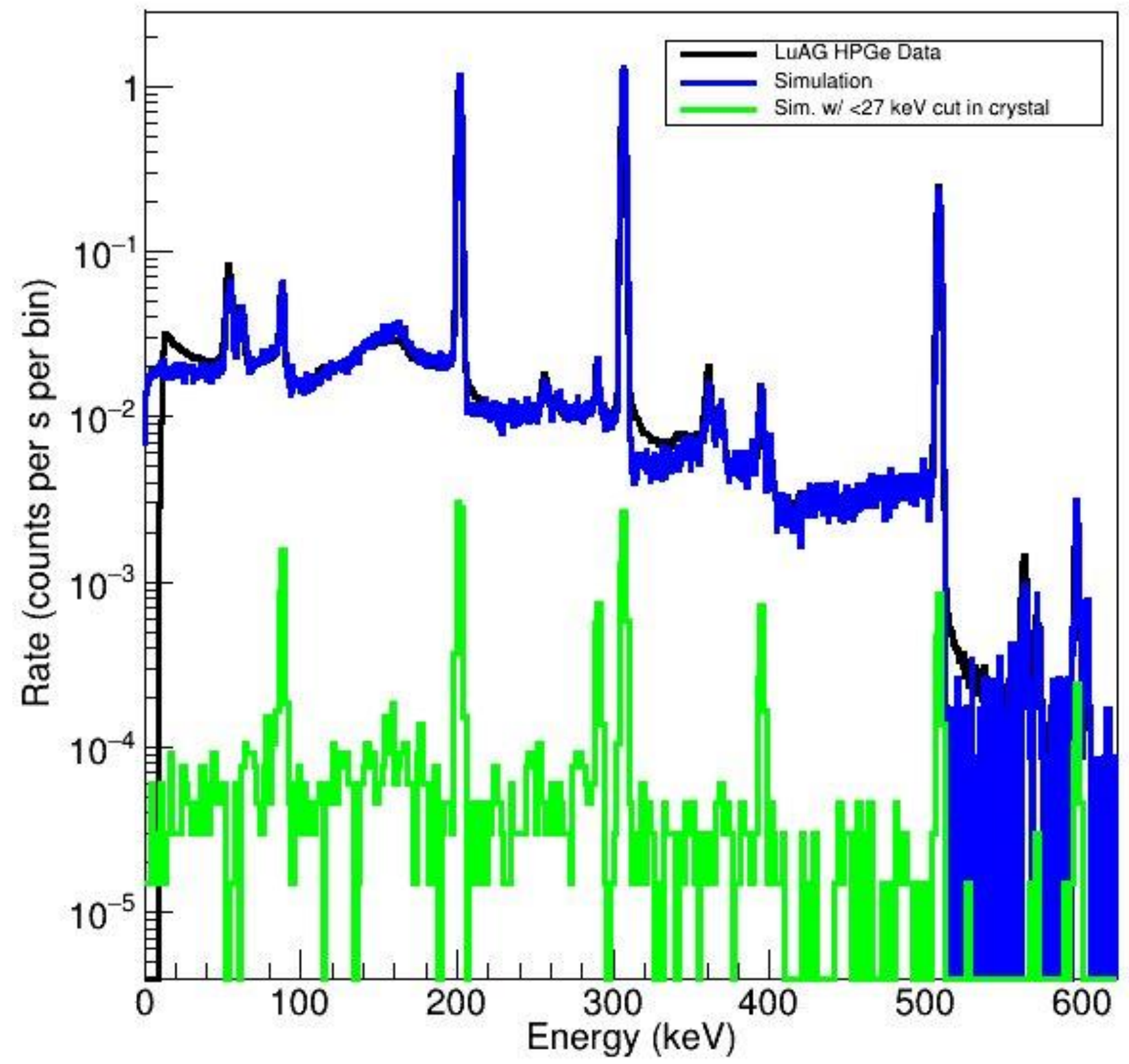

- An energy cut of <27 keV in the SiPM channel will reduce the β - events by >99%
- HPGe has the resolution to separate 82 keV vs. 88 keV

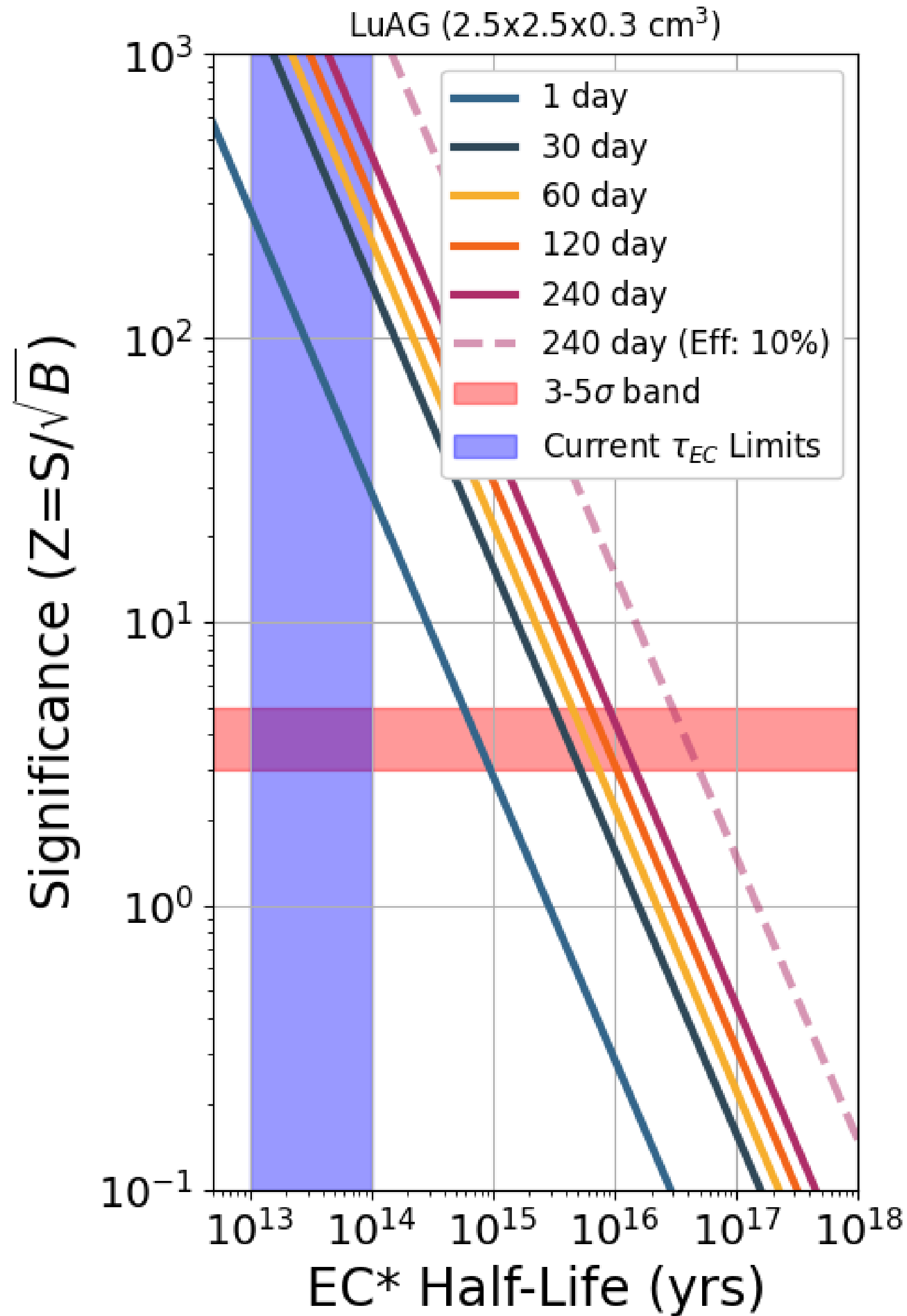
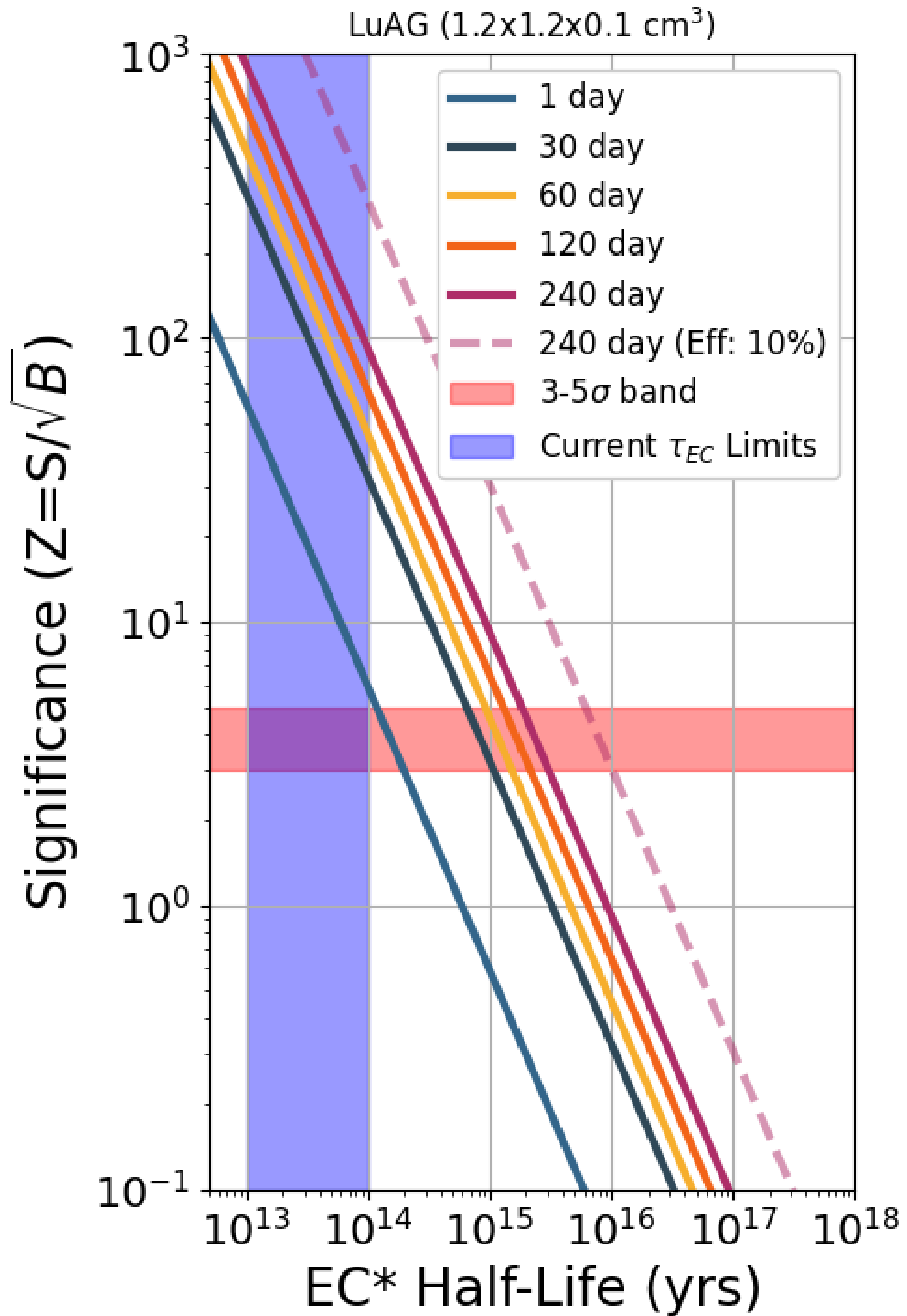

- Meet current limits with a single day of runtime
- Potentially surpass by 2 orders of magnitude
- Actual crystal was 5x5x0.5 cm³

RAMPS: Experimental Setup

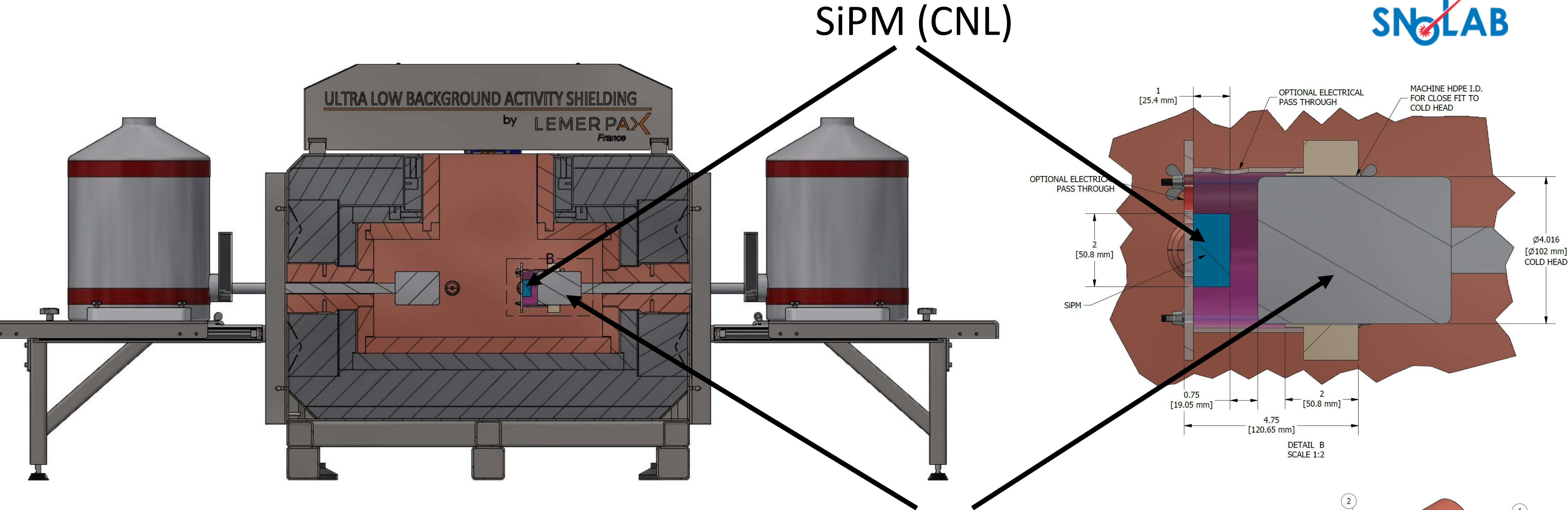

HPGe + Shielding (Health Canada)

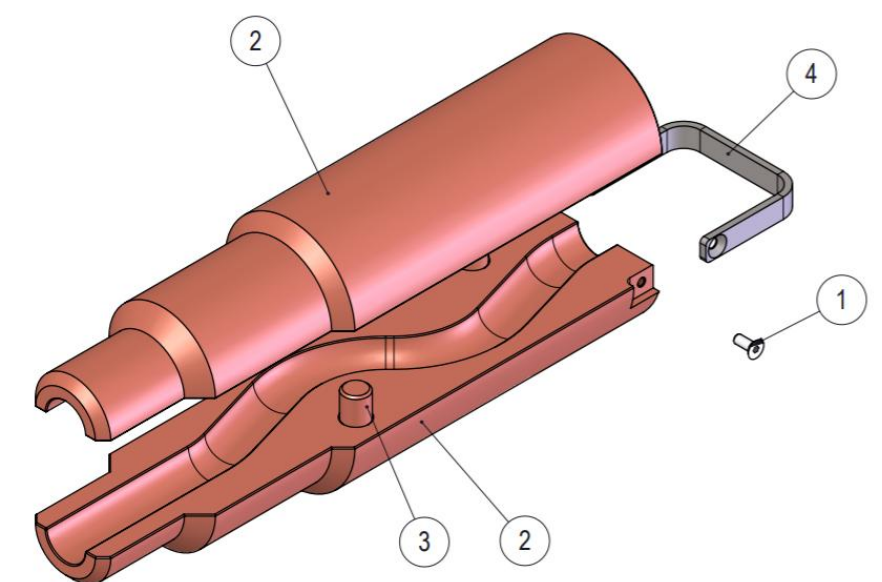
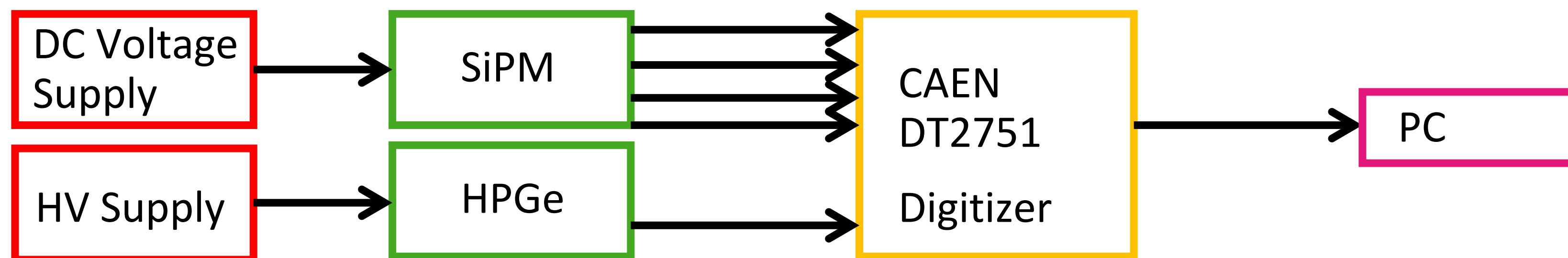

RAMPS: Science Run 1 (March 9th-13th)

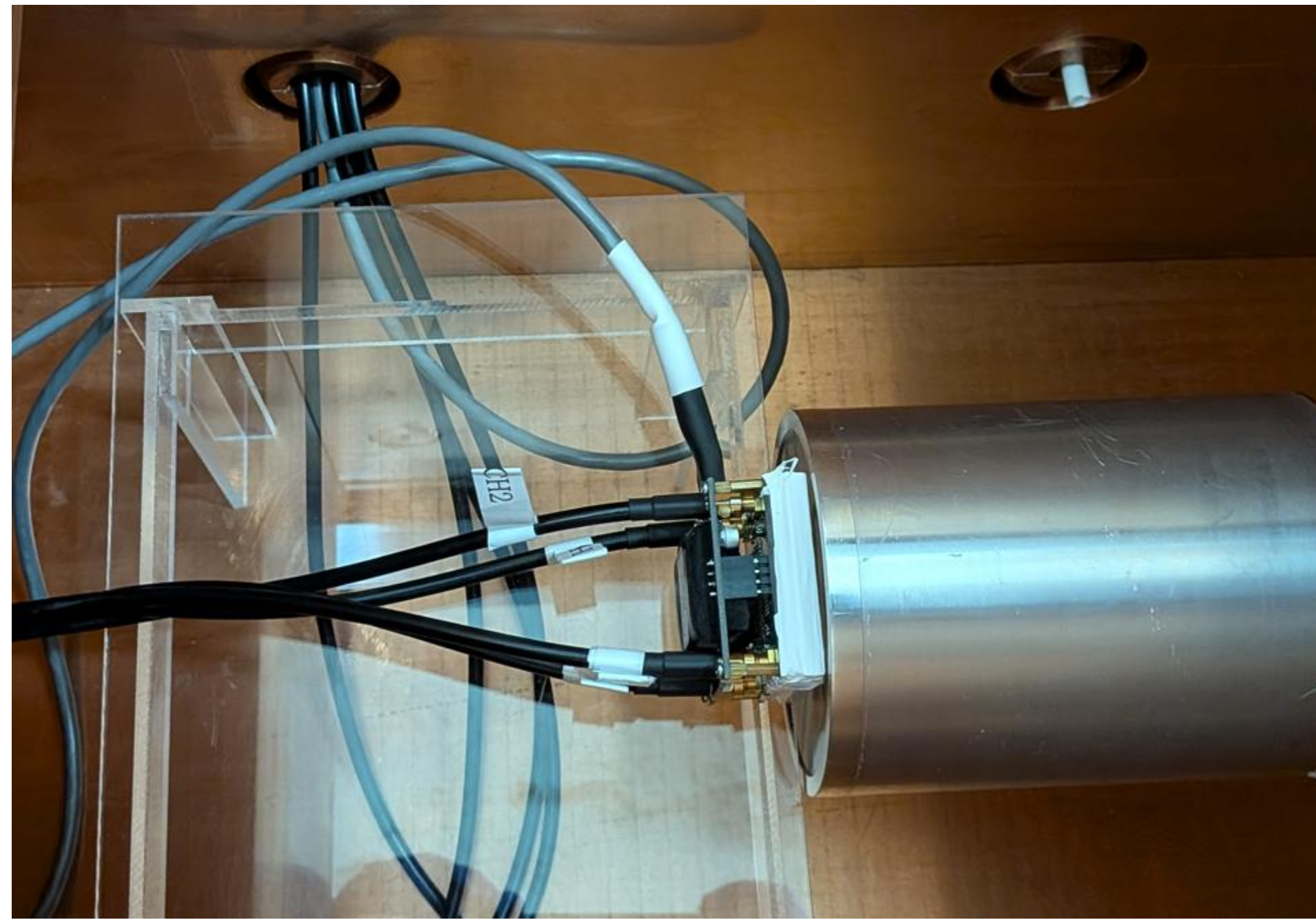

Experimental Setup

First Pulses!

- Over 20 TB of data taken!
- Over 30 hours of science data
- More than 12 hours of calibration data: ^{133}Ba , ^{152}Eu and ^{22}Na

RAMPS Science Run 1: First Pulses

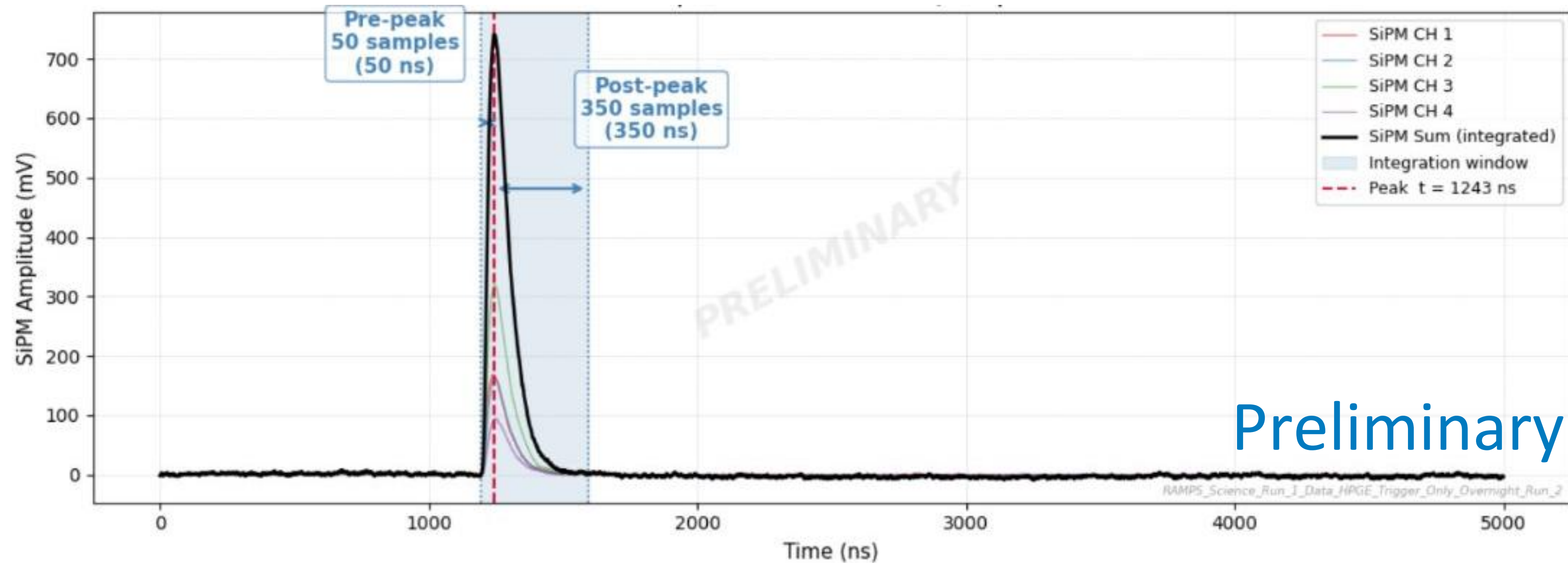
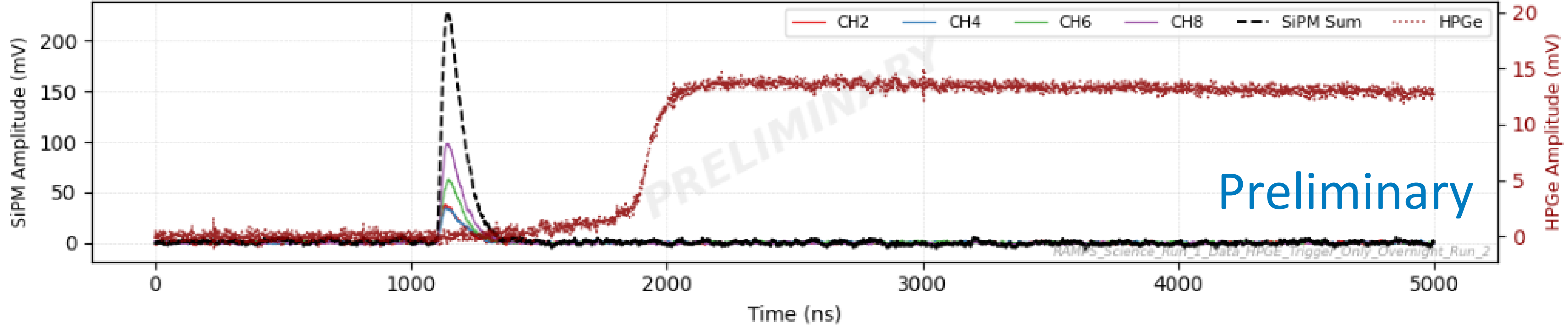

RAMPS Science Run 1: Coincidence Spectrum

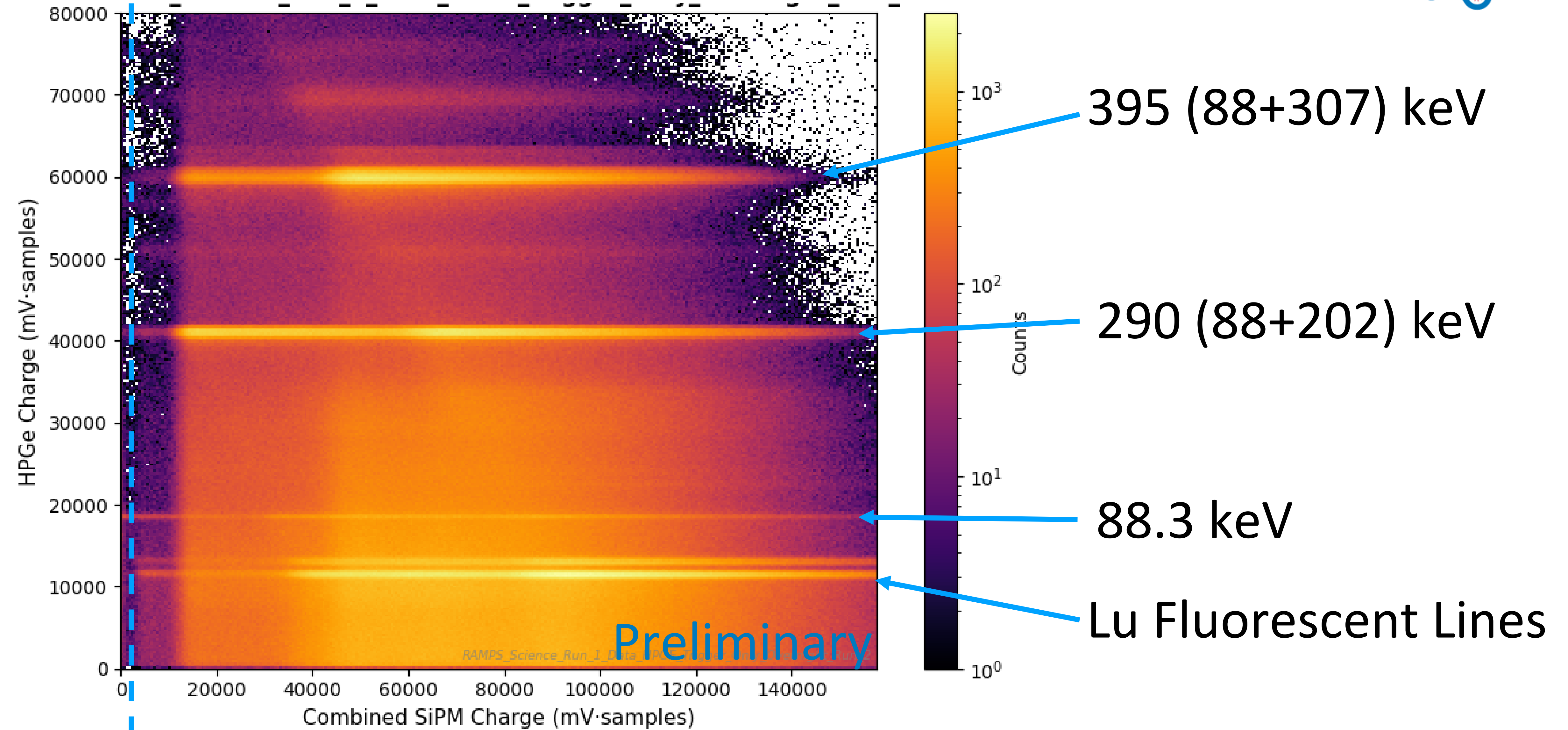

SiPM Cut

RAMPS: Science Run 1 (March 9th-13th) - Preliminary

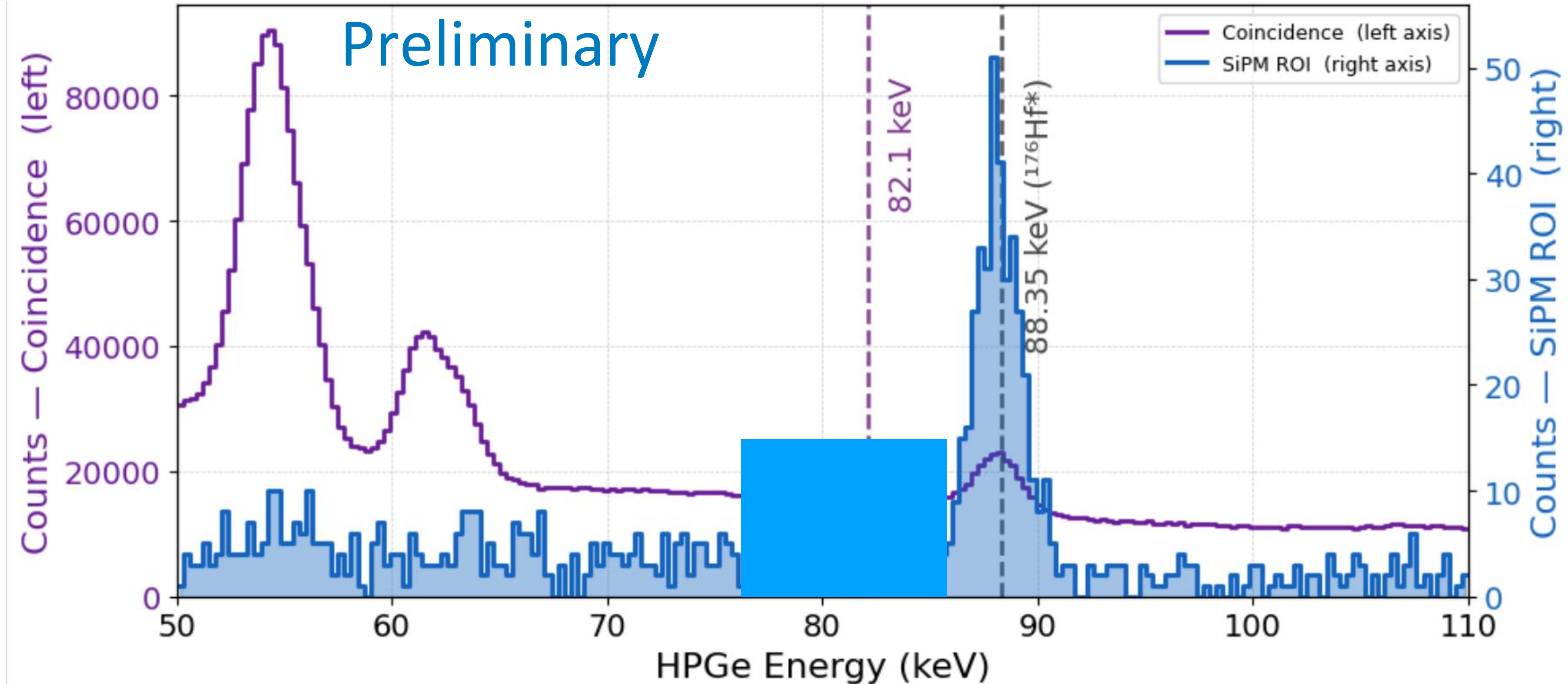

- Over 3 orders of magnitude reduction in β^- background
- Analysis and calibration is ongoing. Results expected this summer
- Measurement of the ^{176}Lu β^- decay, and EC* decay

RAMPS: Future Plans



- Fall 2026: Science Run 2
- Development of SiPM for SNOLAB w/ CNL
- **Precision:** Targeting a CdWO_4 scintillator to measure branching ratio of ^{113}Cd (fourth forbidden non-unique beta decay)
- Combine with the DT-generator to make $^{113\text{m}}\text{Cd}$

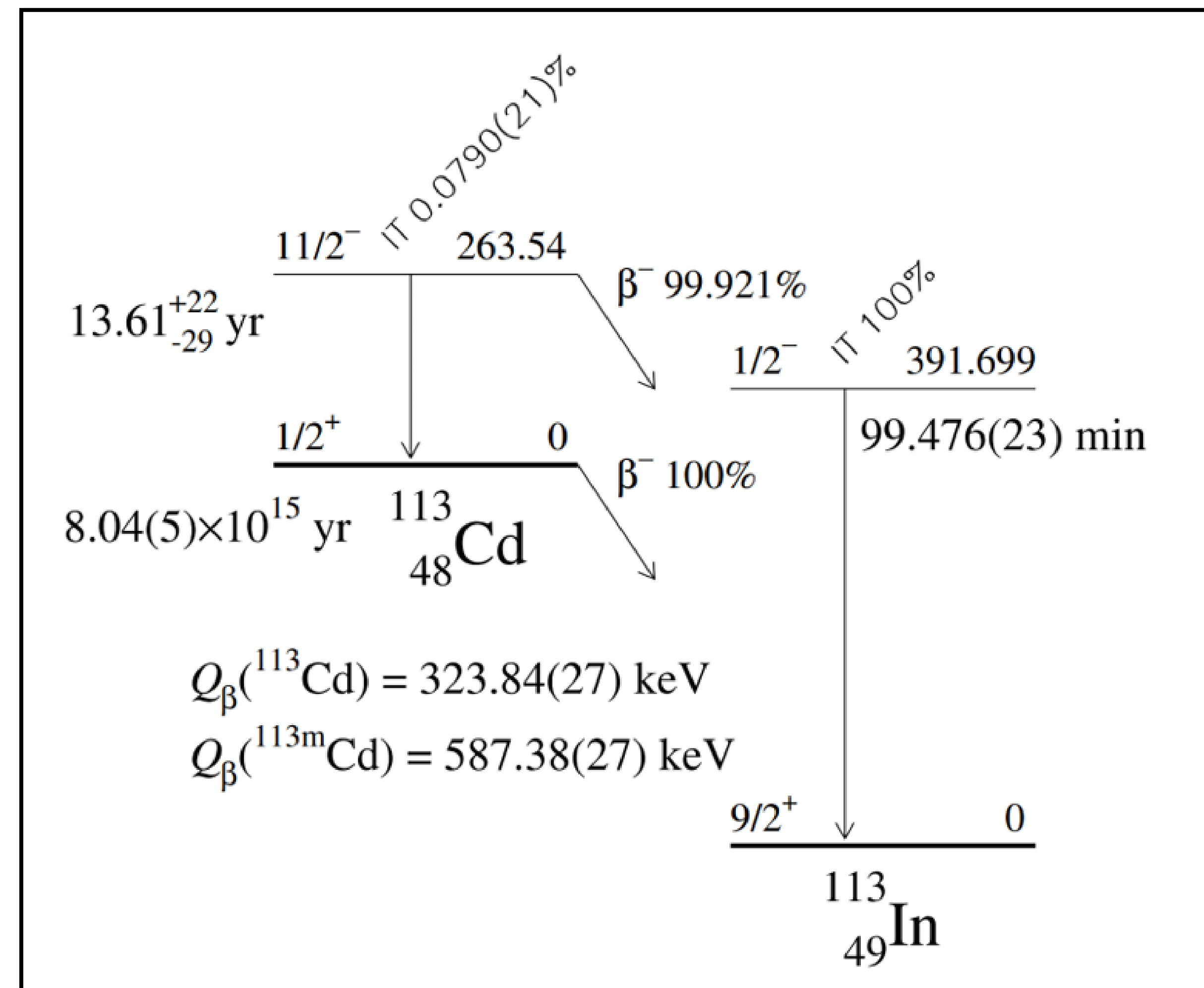

Experimental measurement of forbidden decays: LUCE

LUCE Collaboration:

Shihong Fu¹ · Giovanni Benato^{2,3} · Carlo Bucci³ · Paolo Gorla³ ·
Pedro V. Guillaumon³ · Jiang Li⁴ · Serge Nagorny^{5,8} · Francesco Nozzoli^{6,7}
Lorenzo Pagnanini^{2,3} · Andrei Puiu³ · Matthew Stukel^{2,3}

Rare-event searches with cryogenic calorimeters



Development of a Dual Cryogenic Detection System for the Forbidden Non-unique β -Decay Spectrum Study

<https://doi.org/10.1007/s10909-024-03139-5>

Array of cryogenic calorimeters to evaluate the spectral shape of forbidden β -decays: the ACCESS project

<https://doi.org/10.1140/epjp/s13360-023-03946-x>

Characterization of the Li_2WO_4 crystal as a cryogenic scintillating calorimeter

<https://doi.org/10.1140/epjc/s10052-026-15411-x>

LYSO operated as a cryogenic calorimeter

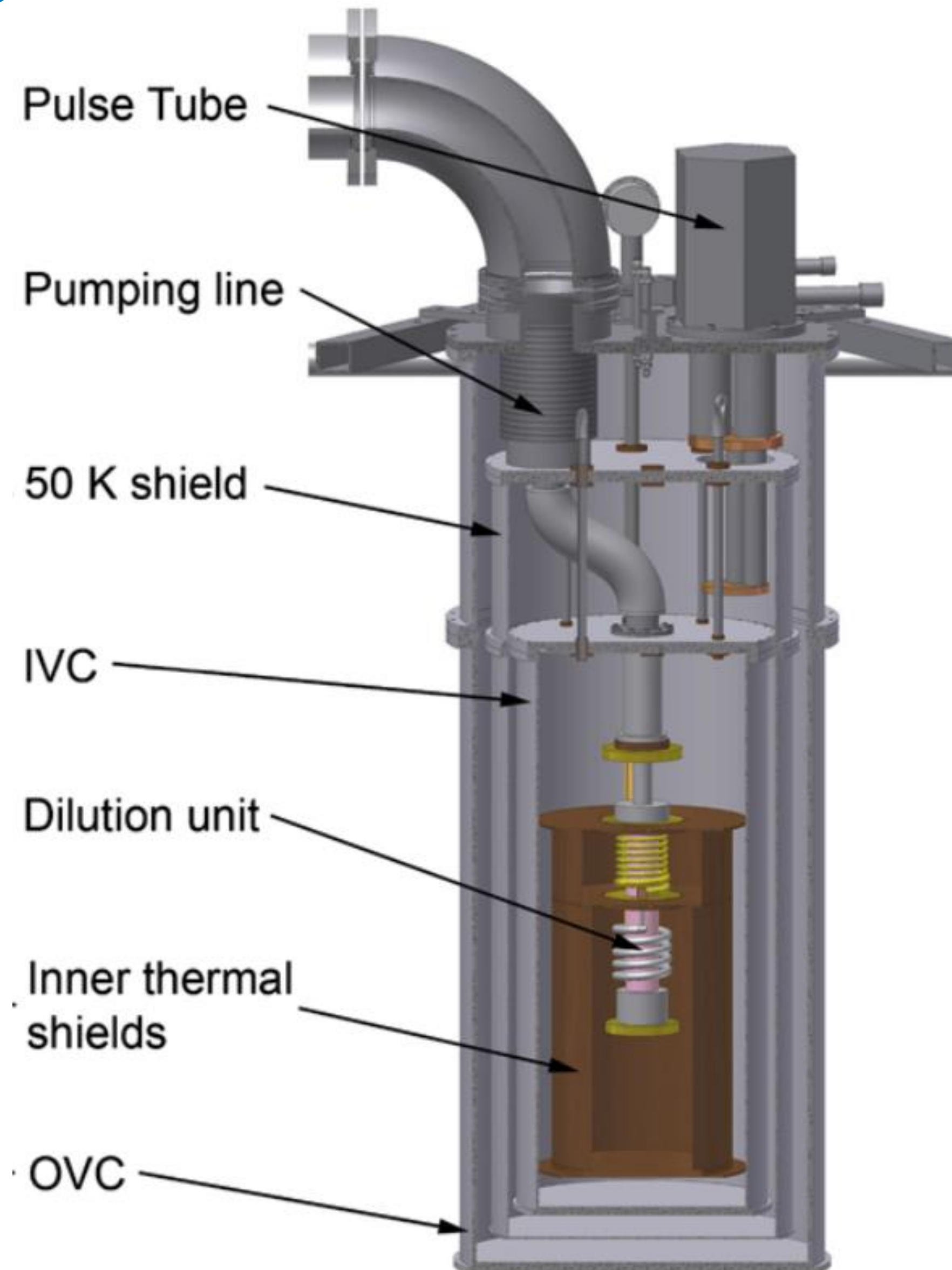
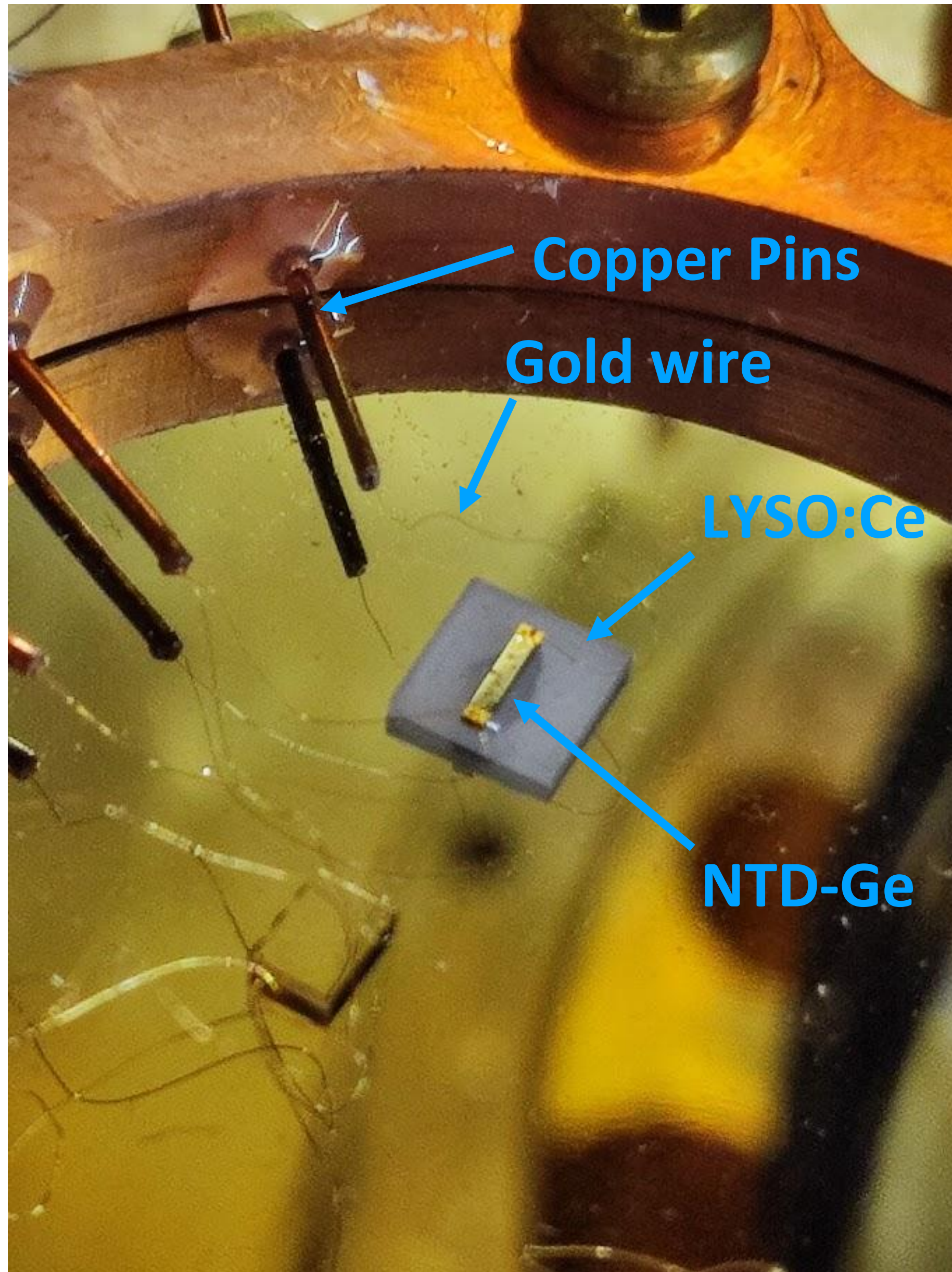

- A 4x4x1 mm LYSO:Ce (0.11g) was operated as a calorimeter at the Ite facility, underground at the Laboratori Nazionali del Gran Sasso
- Crystal was specifically cut so that the rate was < 5 Hz.
- The crystal was equipped with an NTD-Ge and operated at 12 mK for 7 days
- Copper pins and constantan twisted wires make the electrical connection with a board on the MC plate

[Barucci, Marco, Valentina Martelli, and Grecia Ventura. "A Dry Dilution Refrigerator for the Test of CUORE Components." *Journal of Low Temperature Physics* 157.5 \(2009\): 541.](#)

LYSO Cryogenic Calorimeter Results

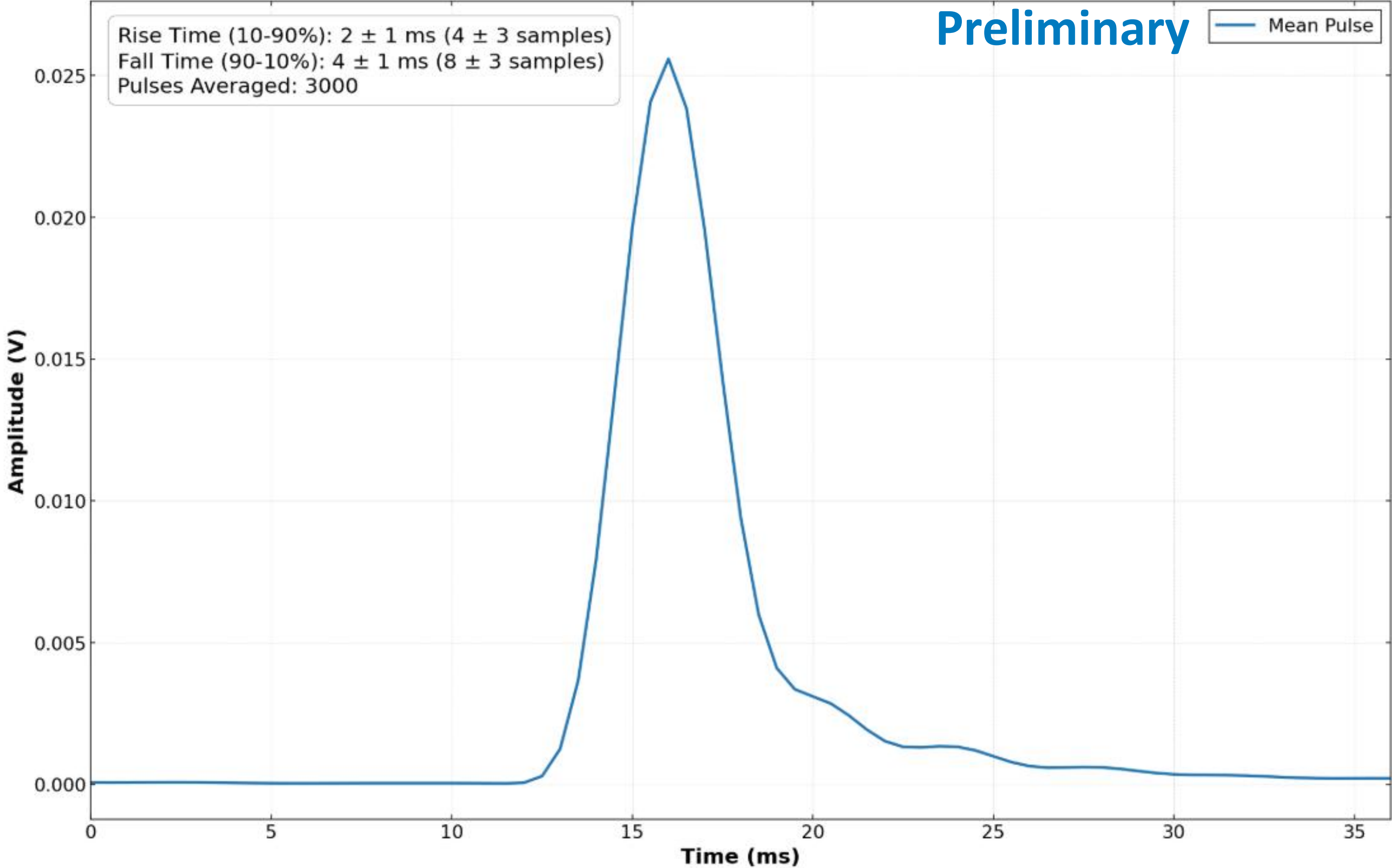

- Data was processed through electronics positioned at room temperature [6]
- The readout electronics consist of low-noise DC coupled front-end boards operated at room temperature and high-resolution digitizers
- Sampling frequency was 2 kHz
- Rise Time (10-90%): **2 ms**
- Fall Time (10-90%): **4 ms**

LYSO Cryogenic Calorimeter Energy Spectrum

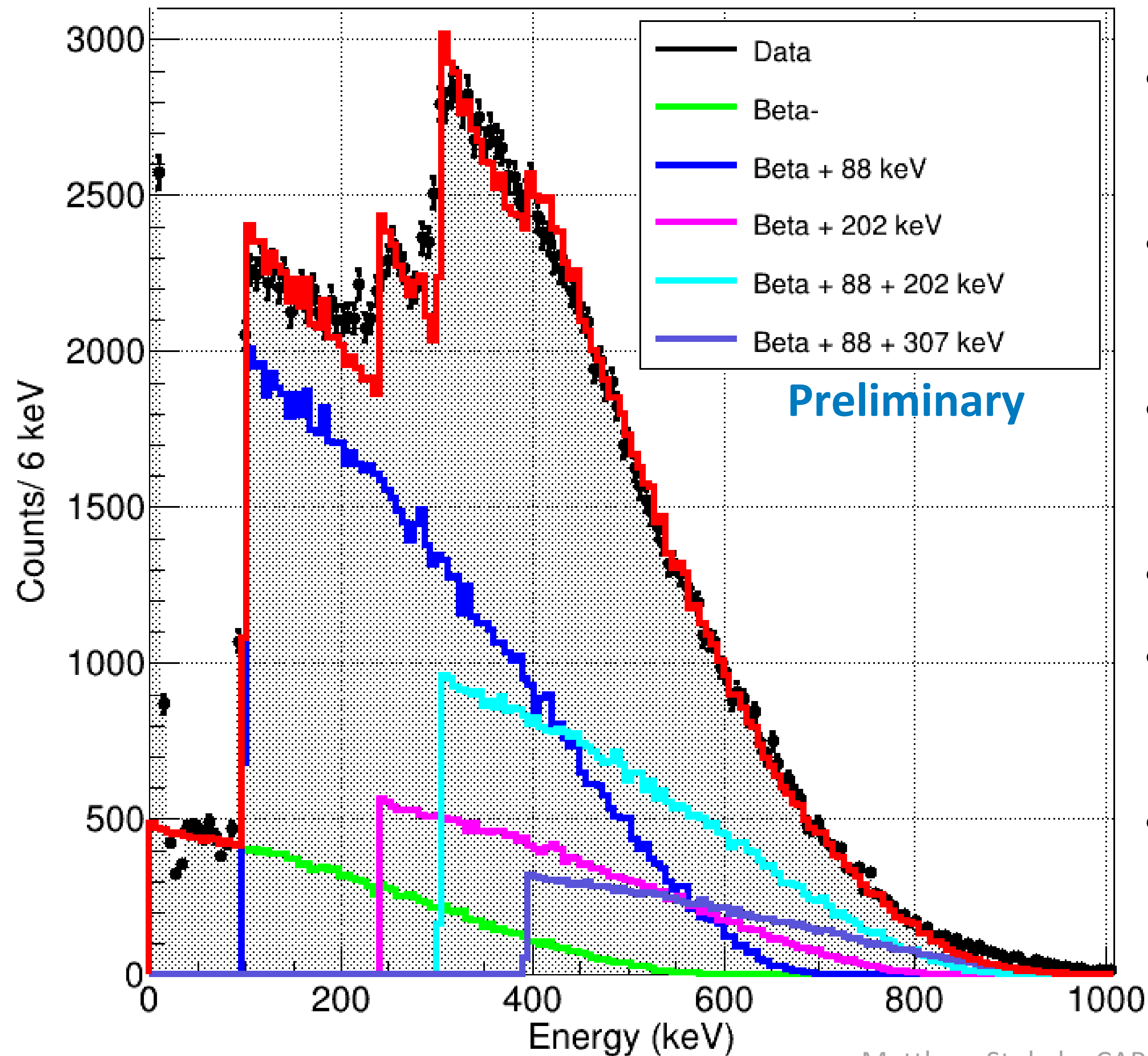

- Demonstrated the first operation of a LYSO crystal as a cryogenic calorimeter
- Plot currently only shows 11 hours of data
- Data was calibrated using the gamma shifts at 88.3 keV and 290 keV
- Threshold = 20 keV
- The β^- spectrum was then simulated in GEANT4, and used to fit the spectra
- Resolution studies are currently ongoing, plan is to use the slope of the beta shifts as well

Conclusion and Future Plans

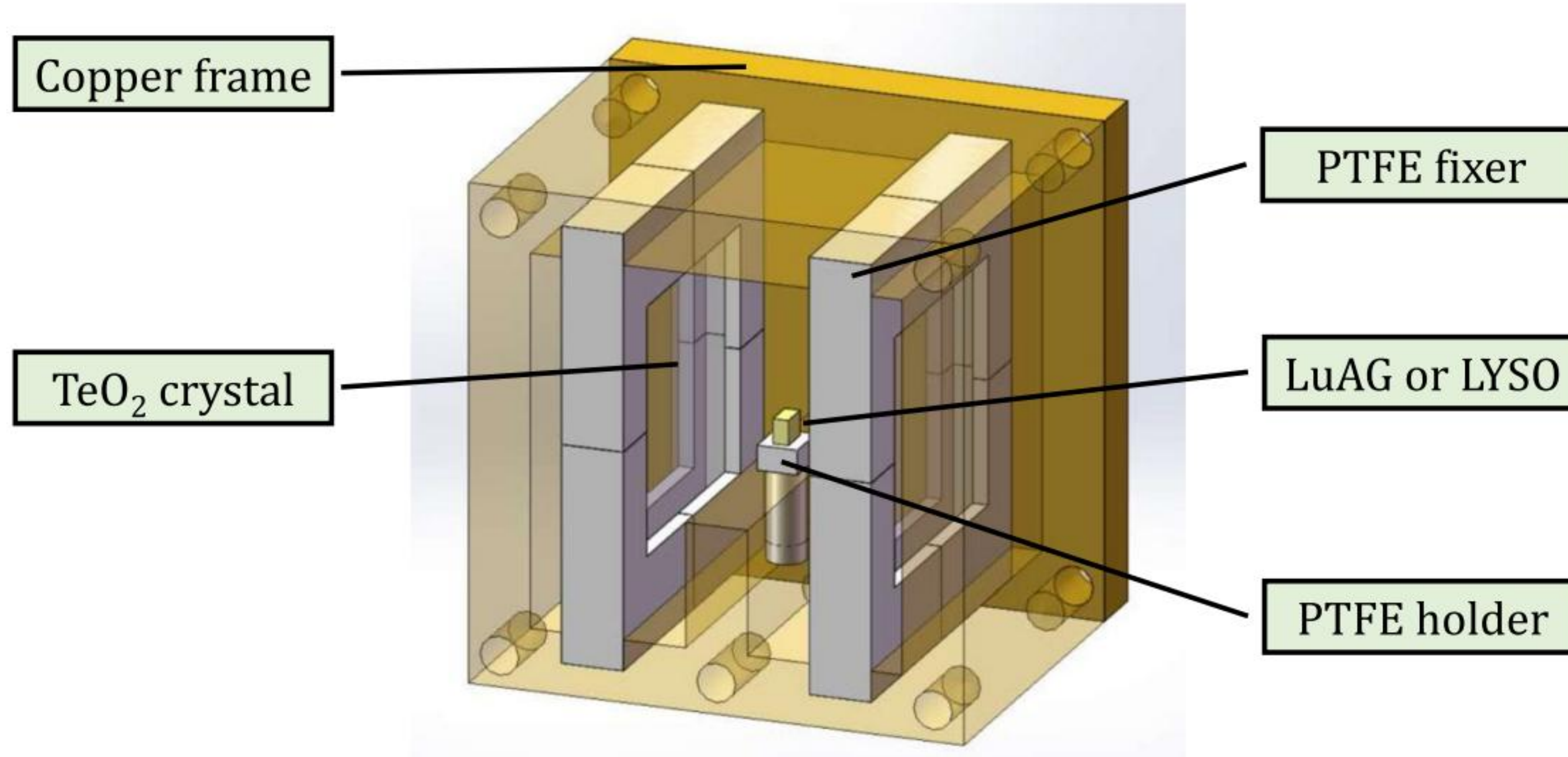

- LYSO has been successfully operated as a cryogenic calorimeter and achieved a threshold that is compatible with the proposed measurement of the excited state electron capture
- Continue R&D effort using transition edge sensors on LuAG and LYSO
- Design and operate coincidence modules for electron capture measurement]

Conclusion



- . Highly forbidden nuclear decays can give us insight into many different areas of physics
 - . KDK: Measured EC of ^{40}K
 - . KDK+: Will measure β^+ of ^{40}K
 - . LUCE/RAMPS: Will measure EC* of ^{176}Lu
 - . Lots more to measure