

ATLAS Upgrades for the High Luminosity LHC

Christoph Klein on behalf of the ATLAS Collaboration

Carleton University – Carleton ATLAS Group

CAP Congress 2026



The Large Hadron Collider (LHC)

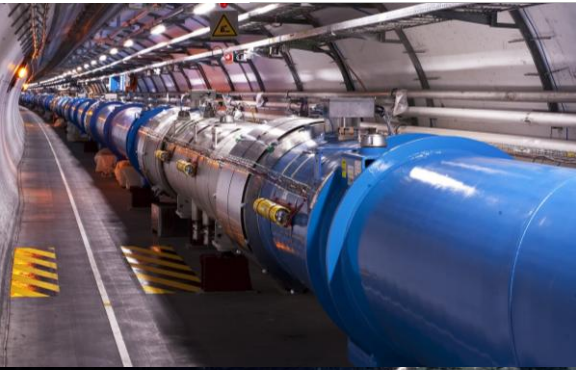

- circumference 27 km
- 100 m underground

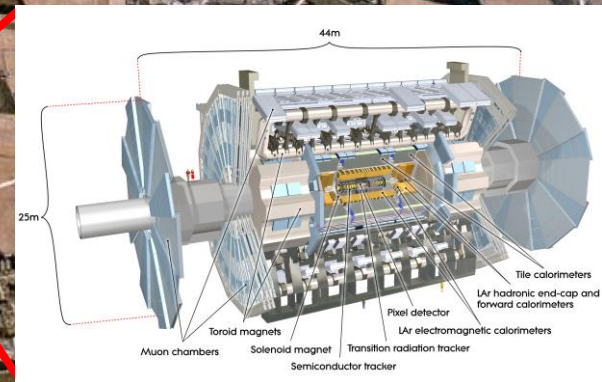



The Large Hadron Collider (LHC)

- largest and most energetic hadron collider
- proton-proton or heavy ion operation
- centre of mass energy of up to 13.6 TeV
- collision intervals (bunch crossing) of 25 ns
- several large experiments: [ATLAS](#), CMS, LHCb, ALICE

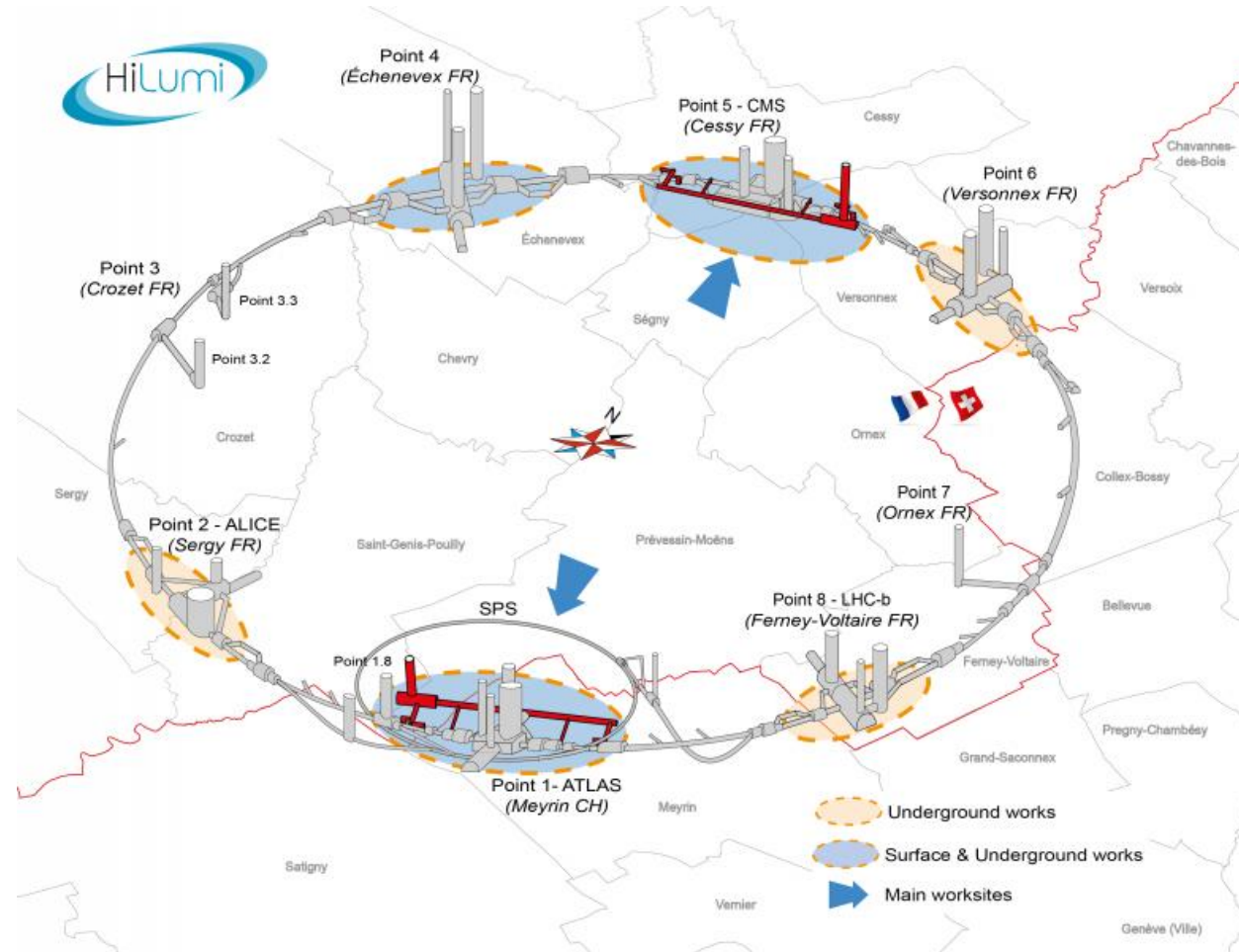



The Large Hadron Collider (LHC)

- largest and most energetic hadron collider
- proton-proton or heavy ion operation
- centre of mass energy of up to 13.6 TeV
- collision intervals (bunch crossing) of 25 ns
- several large experiments: [ATLAS](#), CMS, LHCb, ALICE

The CERN accelerator complex
Complexe des accélérateurs du CERN

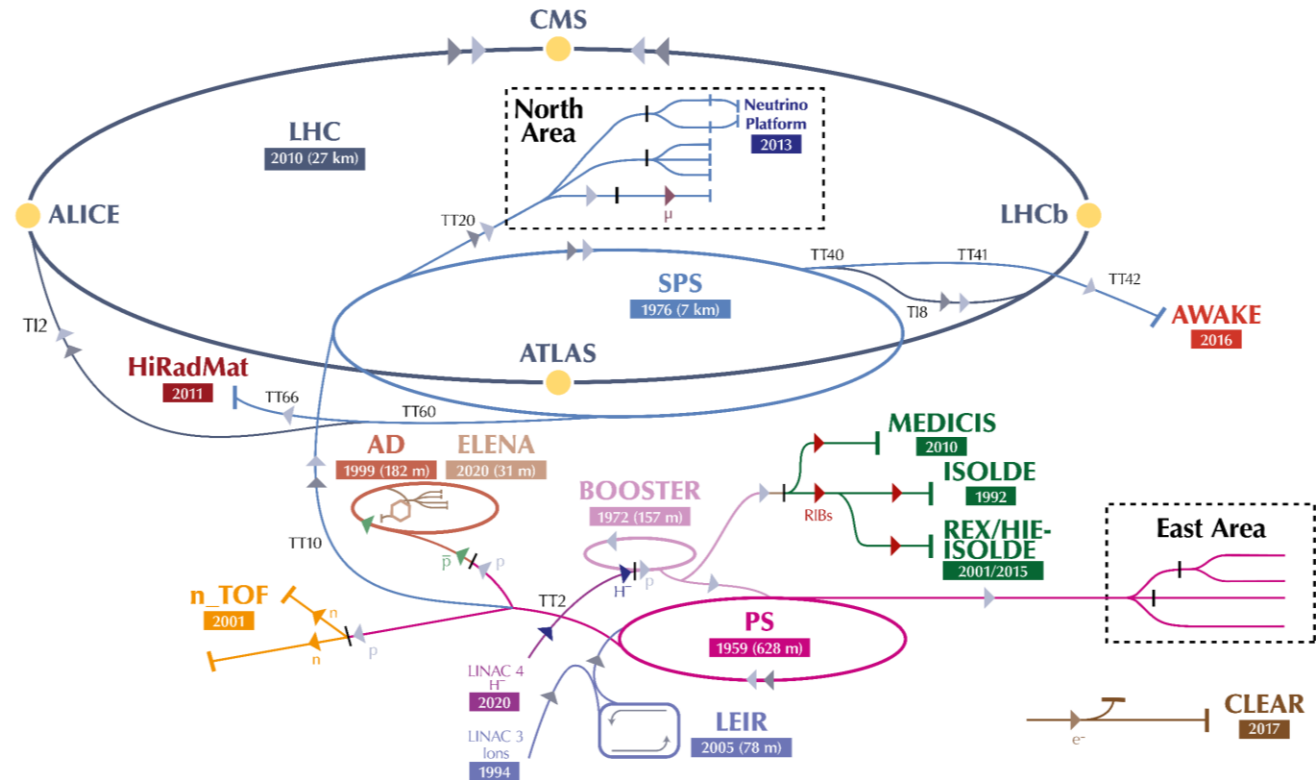



LHC Schedule

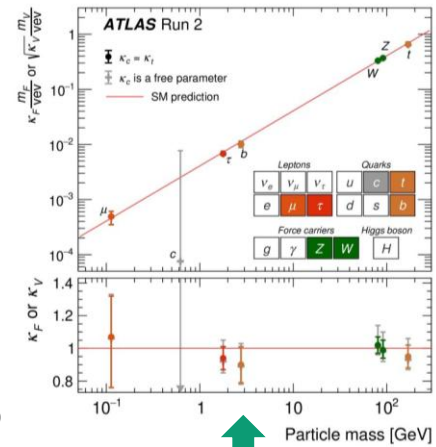
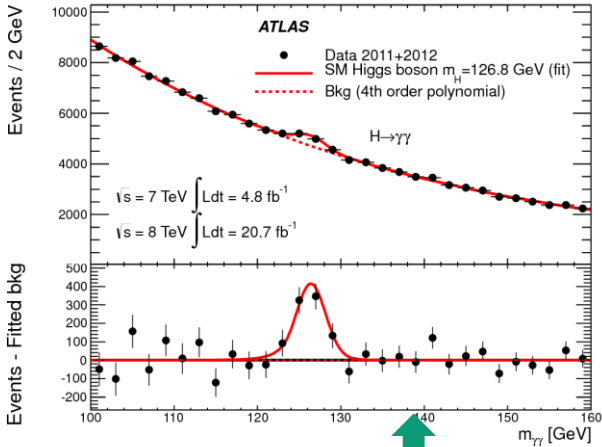

- currently at the end of Run 3, just before the next long shutdown (LS3)
- LS3 marks beginning of Phase-II of LHC operation
 - major performance upgrades towards high luminosity
- new technological challenges w.r.t. radiation damage, detector occupancy, and bandwidth saturation



[HL-LHC project website](#)



LHC Upgrade: High-Luminosity LHC

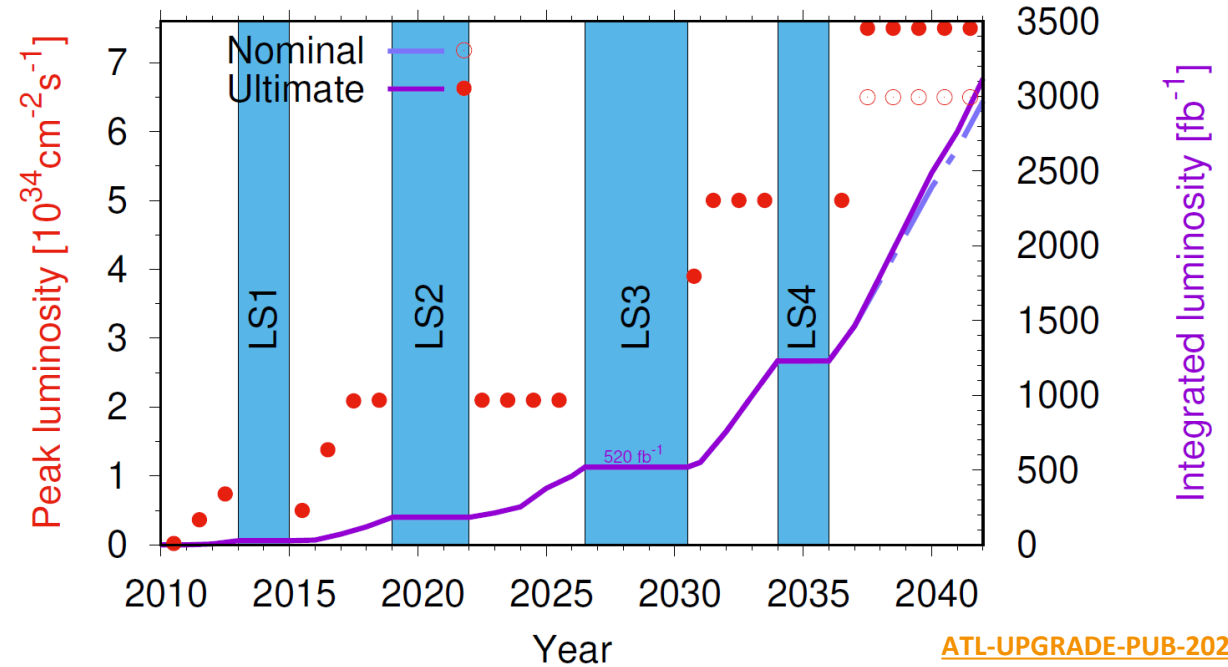
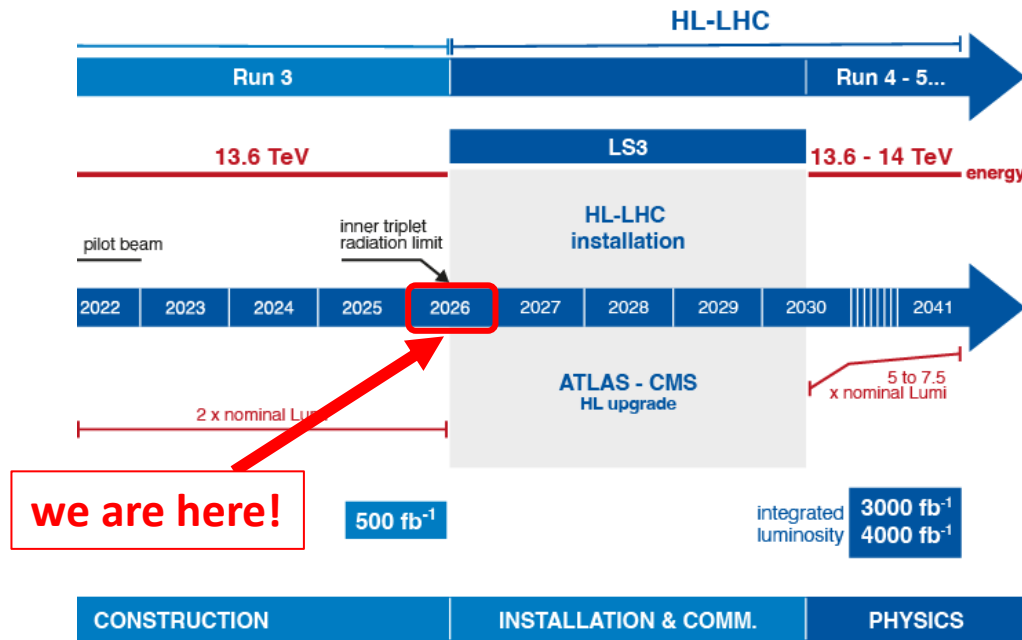

ATL-UPGRADE-PUB-2025-001

- Run 3 peak luminosity $2.3 \times 10^{34} \text{ cm}^{-2} \text{ s}^{-1}$ @13.6 TeV, integrated luminosity 540 fb^{-1} (May 2026)
- Run 4 peak luminosity up to $7.5 \times 10^{34} \text{ cm}^{-2} \text{ s}^{-1}$ @14 TeV, integrated luminosity 3000 fb^{-1}
- experiments need to undergo upgrades to cope with demanding HL-LHC conditions



The ATLAS Detector

- collision data since 2009
- multipurpose detector
 - tracking and vertex detector
 - calorimeters
 - muon system
- dimensions: 44 × 25 m
- weight: ~7000 t

ATLAS collaboration:

- >3000 scientists
- 170+ institutions (9x )
- 40 countries

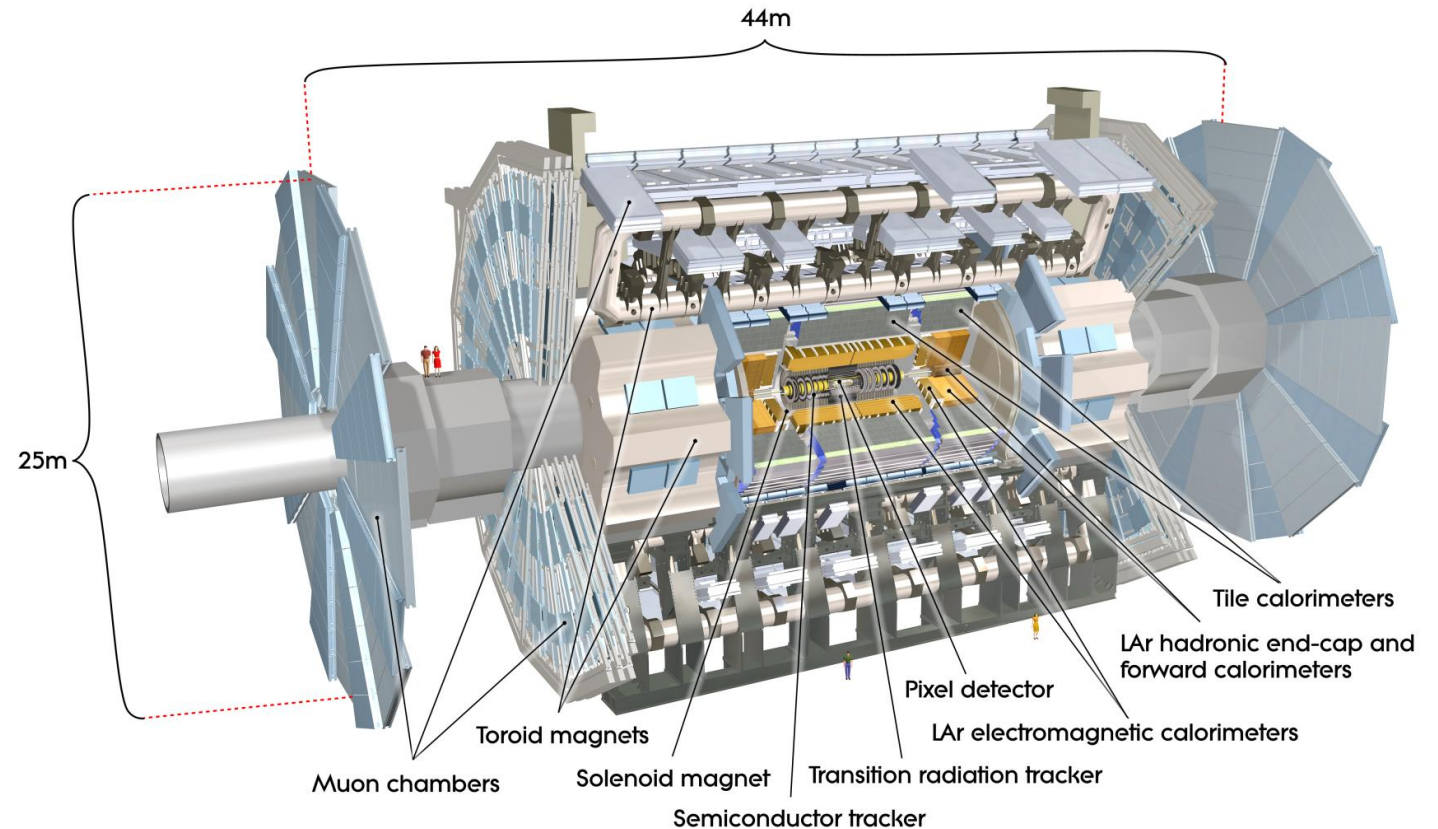



ATLAS after HL-LHC Upgrade



- after Phase-II upgrade, HL-LHC will deliver more than 3x Phase-I peak luminosity
 - up to 200 p-p interactions per bunch crossing
 - ~10x more track density
 - higher radiation levels

ATLAS Radiation Simulation
Public Results

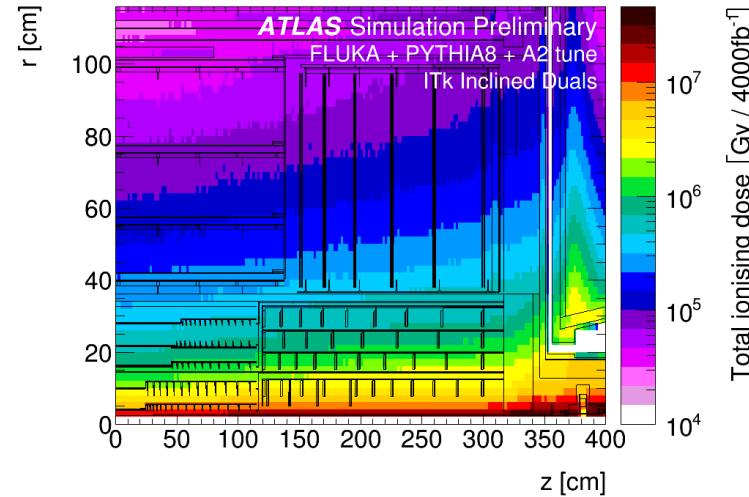

- current ATLAS Detector **cannot** cope in HL-LHC conditions
 - too much accumulated radiation damage
 - saturated bandwidth
 - occupancy too high for tracking algorithms

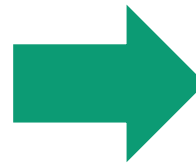
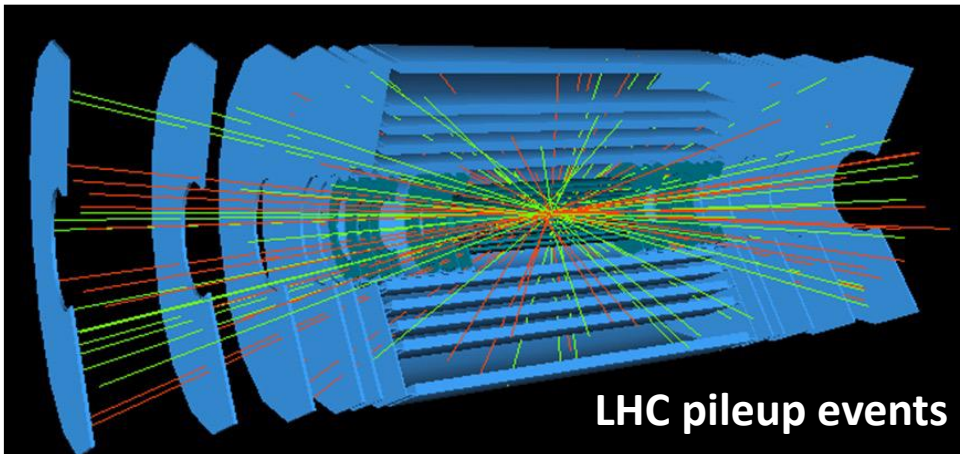

ATL-UPGRADE-PROC-2012-003

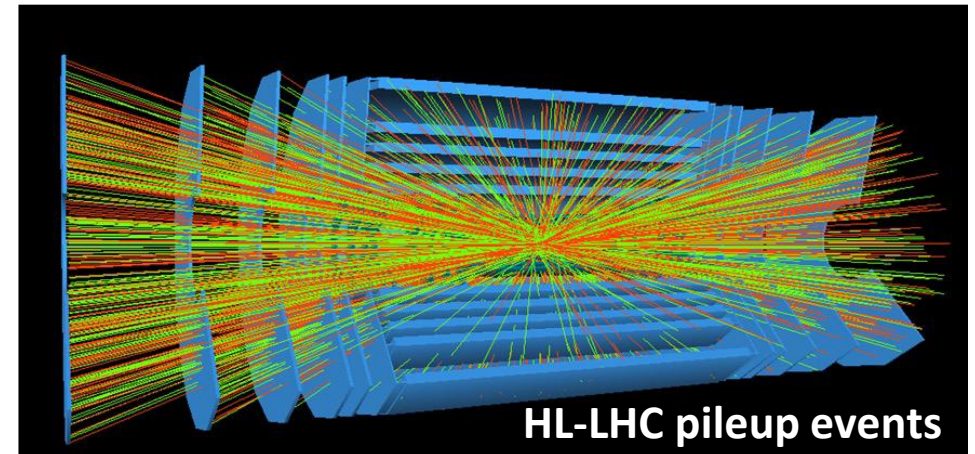



Phase-II ATLAS Upgrades

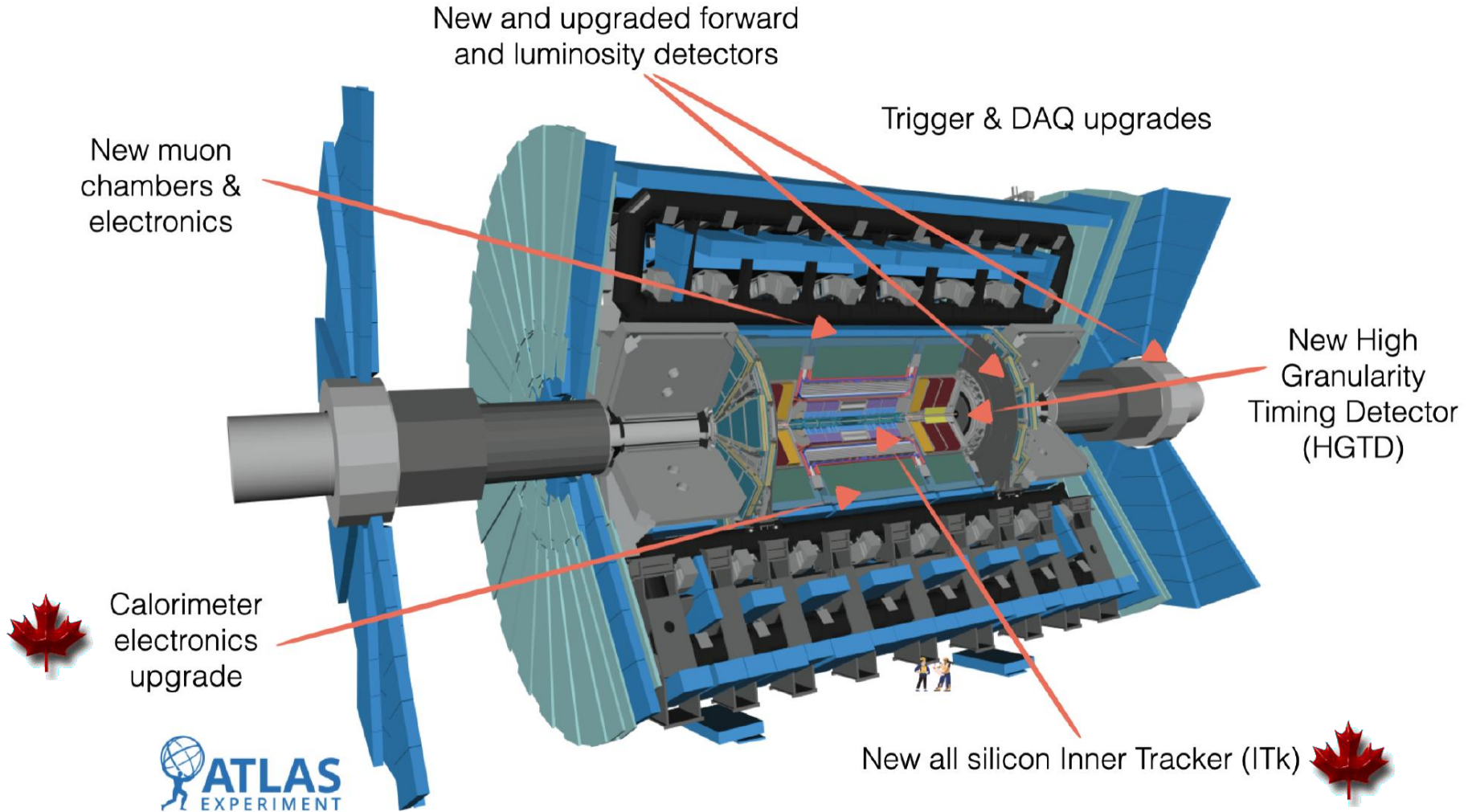



ATLAS LAr Calorimeter

- Liquid Argon (LAr) sampling calorimeters in ATLAS:
 - accordion geometry EM calorimeters in barrel (EMB) and end-cap (EMEC)
 - parallel-plate hadronic end-cap (HEC)
 - paraxial electrode forward (FCal)
- total pseudorapidity coverage $|\eta| < 4.9$ (i.e. forward coverage in direction of beam pipe)
 - current LAr readout electronics not compatible with Phase-II conditions
 - increased latency and trigger rate
 - radiation hardness requirements

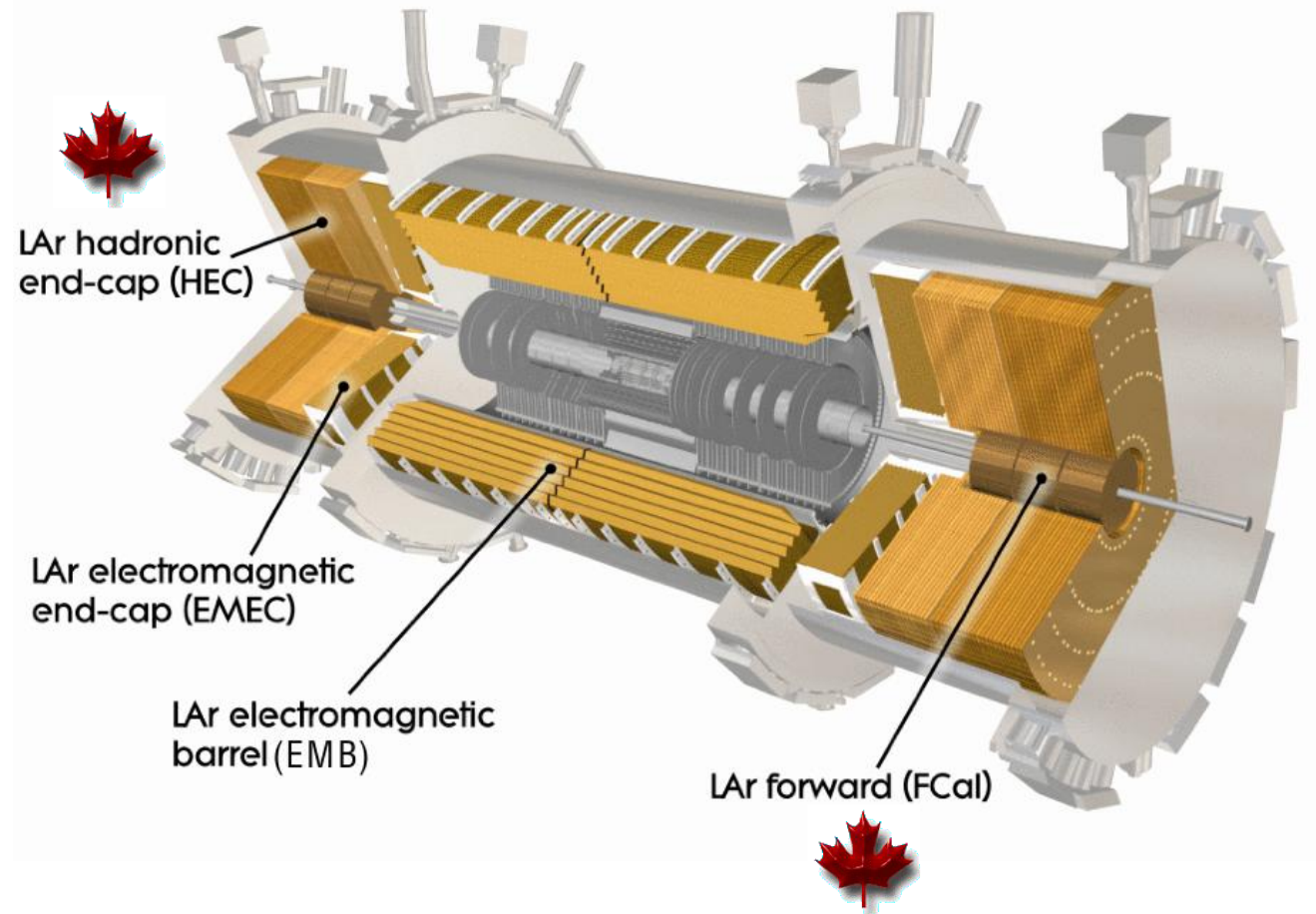



LAr Calorimeter Phase-II Upgrades

- digitize and stream calorimeter data from new on-detector electronics to new off-detector electronics at 40 MHz
 - use digital trigger readout installed during Phase-I (LS2) update
- 40 MHz continuous readout of entire calorimeter with full precision
- improved radiation hardness
- new LV power supplies in radiation zone for on-detector electronics
- Canadian contributions to Front-End Board (FEB2) and LAr Signal Processor (LASP)

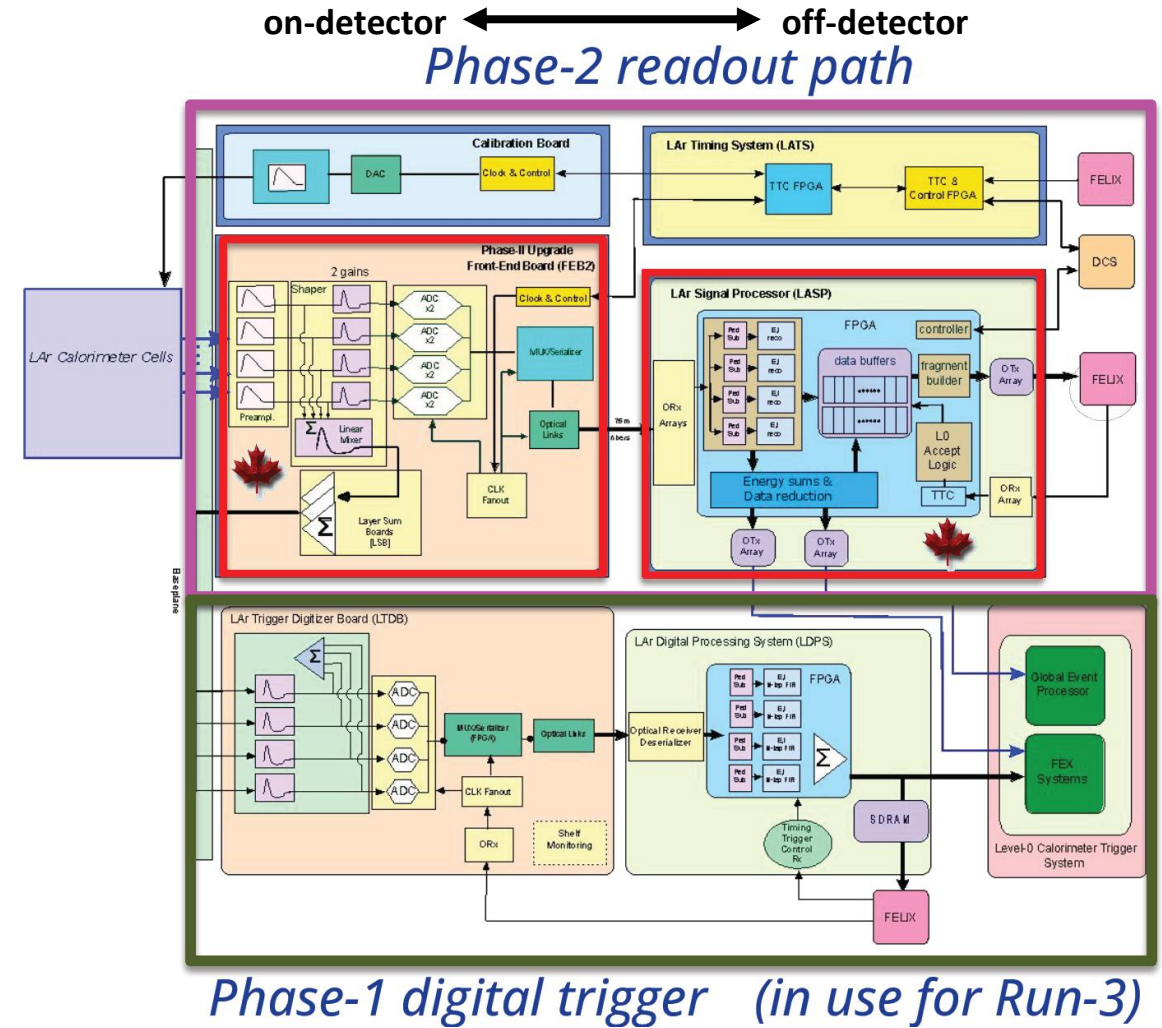



The ATLAS Inner Detector

- ATLAS Inner Detector (ID)
 - pixel detector
 - semiconductor tracker (SCT)
 - transition radiation tracker (TRT)
- coverage up to $|\eta| < 2.5$

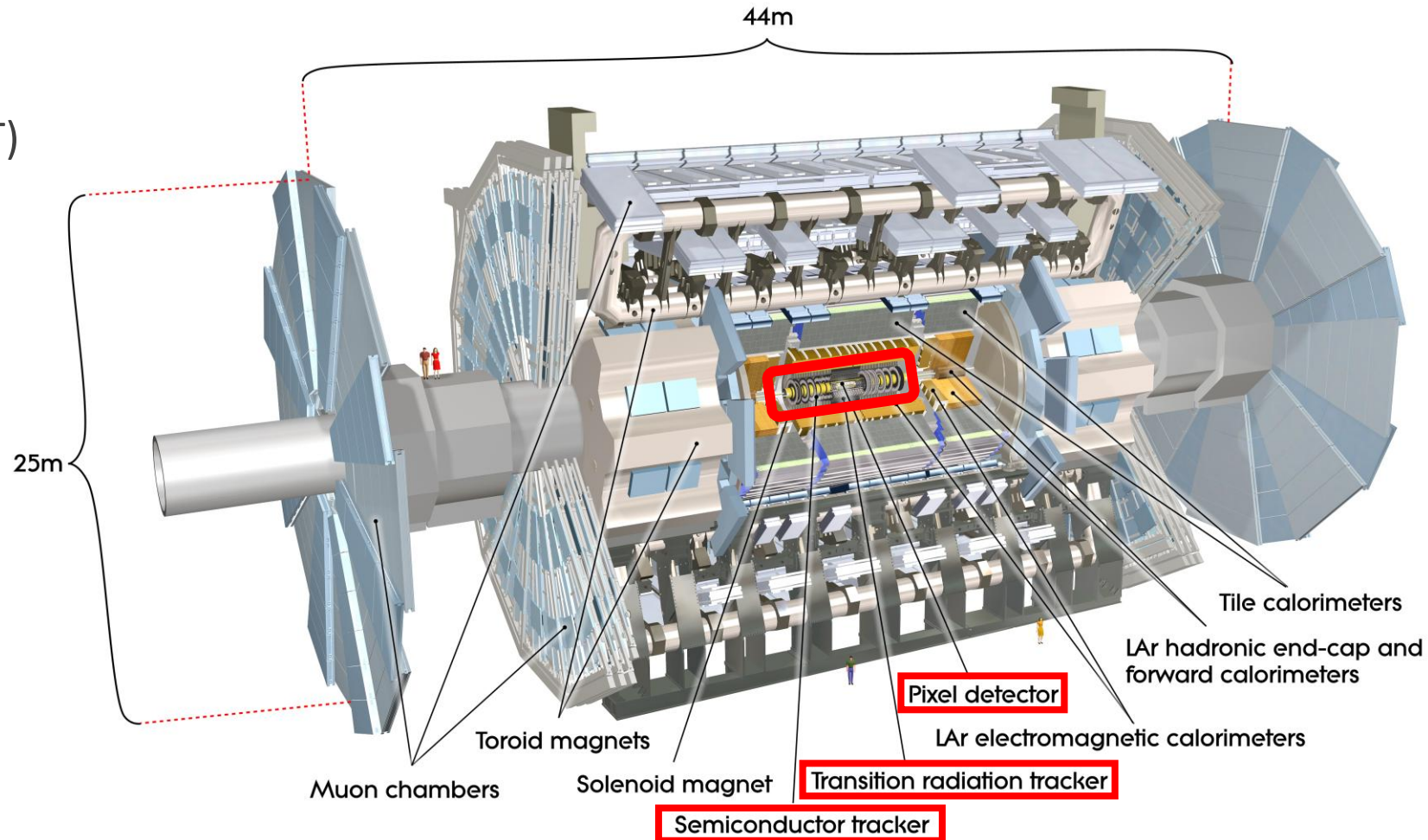



The ATLAS Inner Detector

- ATLAS Inner Detector (ID)
 - pixel detector
 - semiconductor tracker (SCT)
 - transition radiation tracker (TRT)
- coverage up to $|\eta| < 2.5$

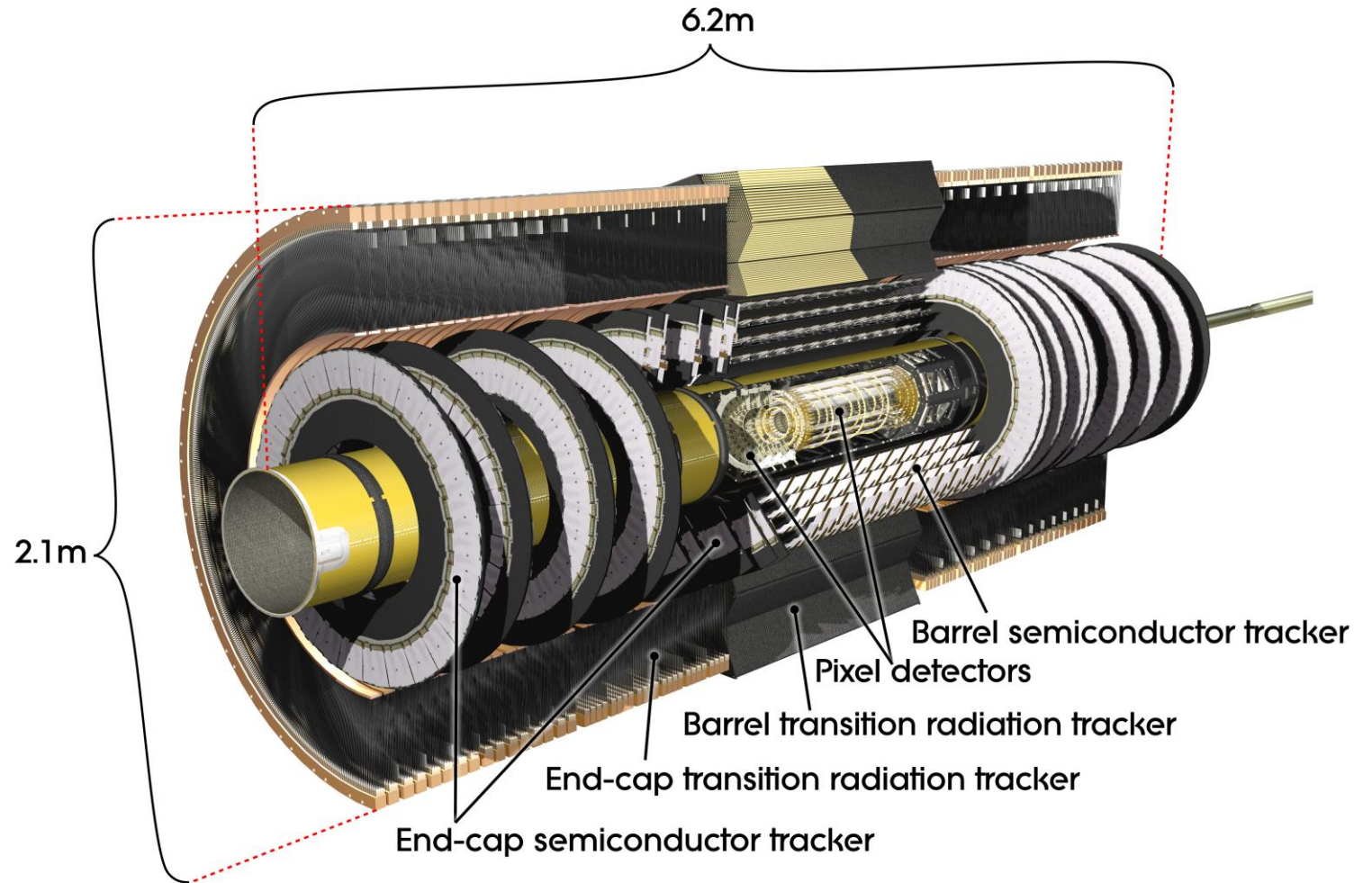
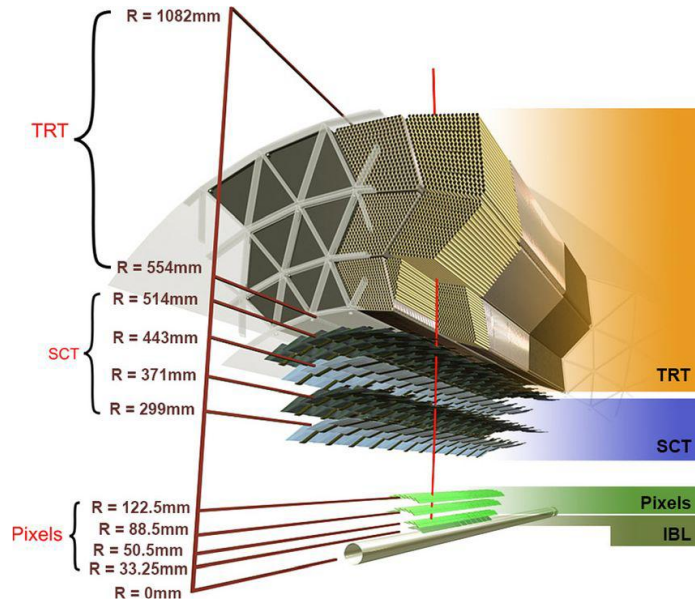



The ATLAS Inner Tracker (ITk) Upgrade

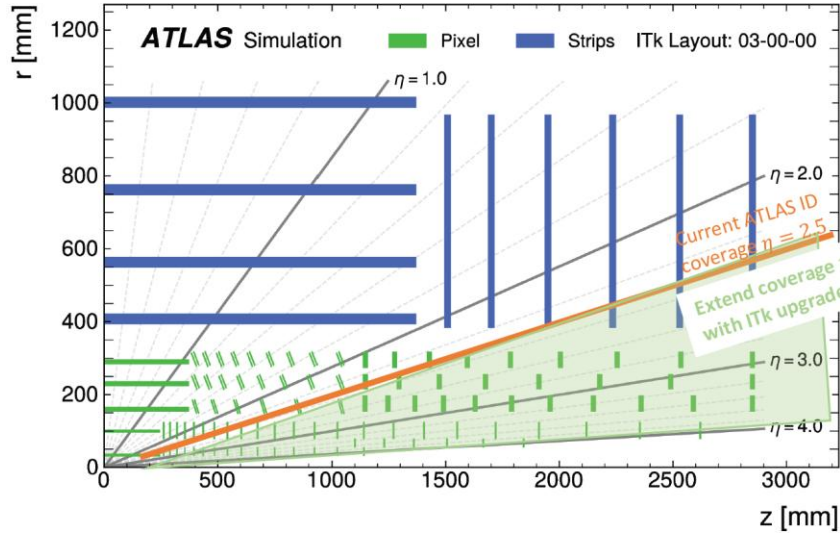

JINST 20 (2025) P02018

- all-silicon tracker
 - higher granularity
 - extended coverage $|\eta| < 2.5 \rightarrow 4.0$
 - increased radiation hardness
 - faster readout

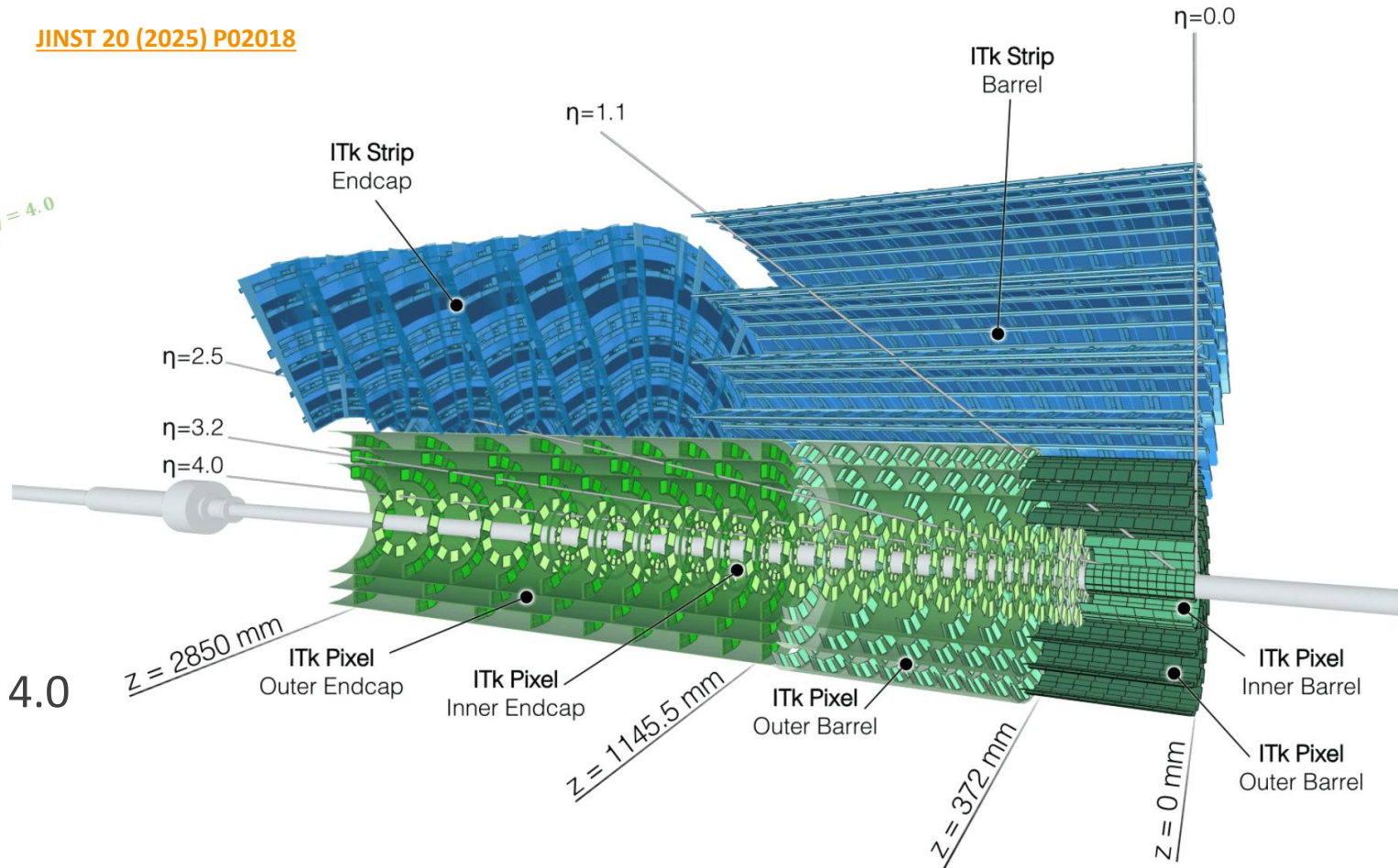



The ATLAS Inner Tracker (ITk) Upgrade

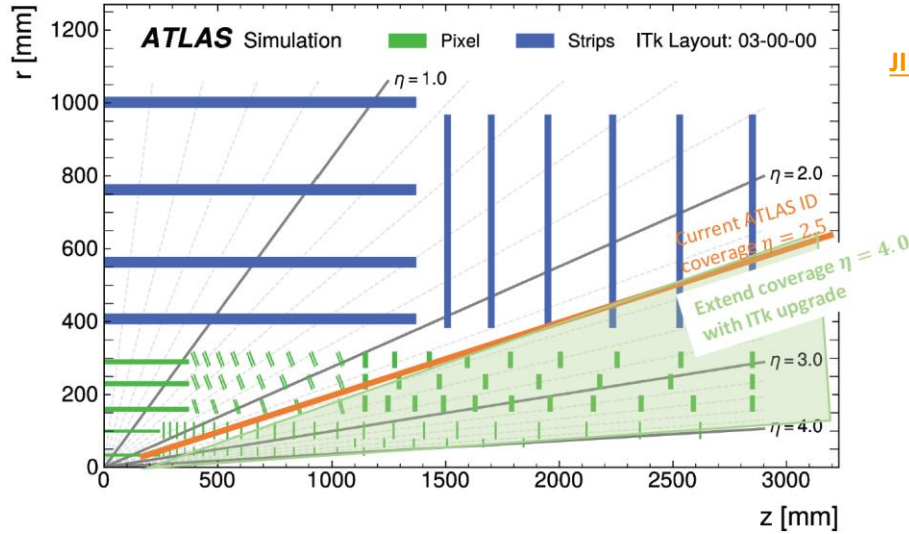

JINST 20 (2025) P02018

ITk pixel detector:

- close to beamline
- 5 barrel layers (flat + inclined)
- novel pixel rings in end-cap
- two innermost pixel layers (inner system) are replaceable
- >5 billion readout channels

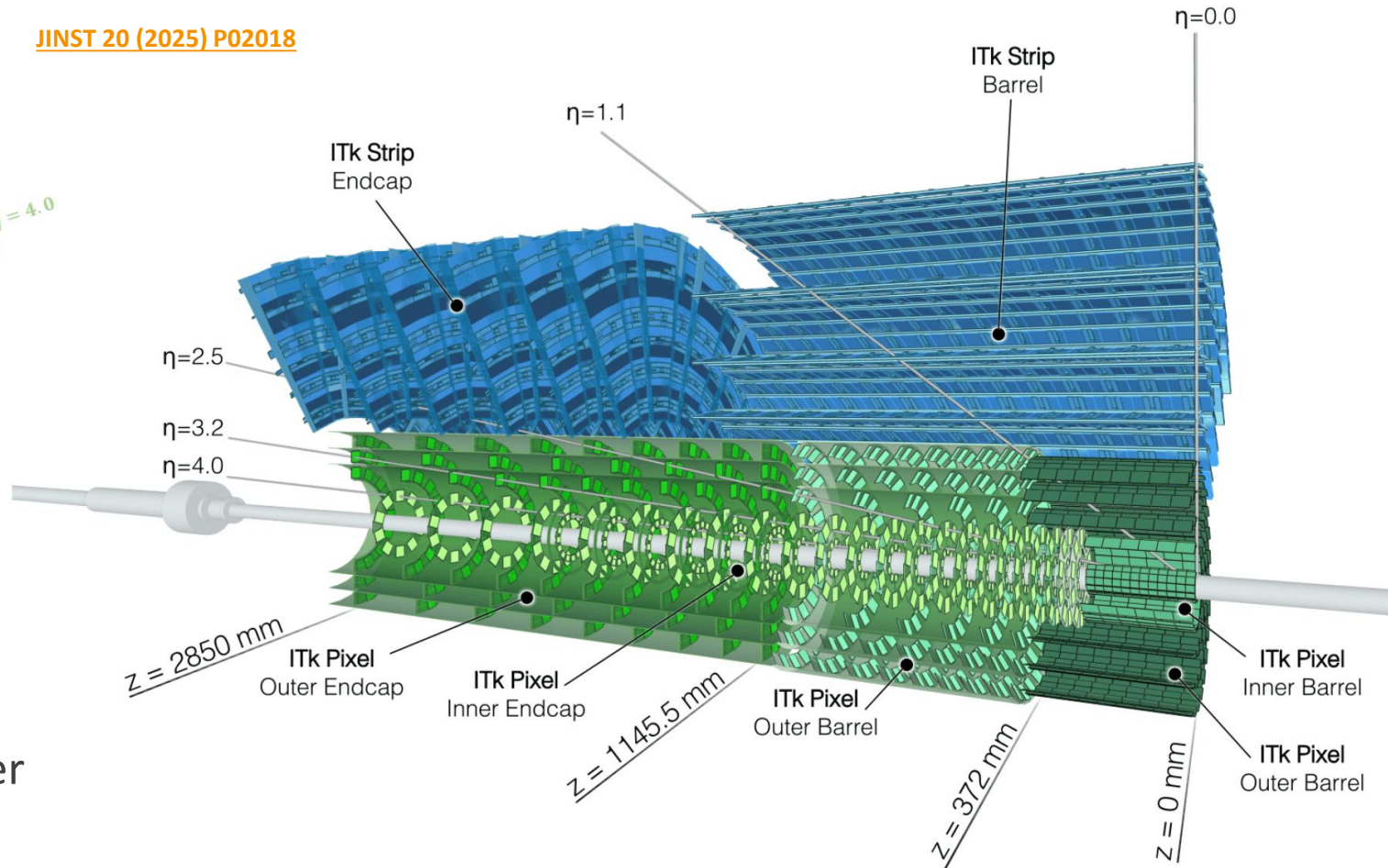



The ATLAS Inner Tracker (ITk) Upgrade

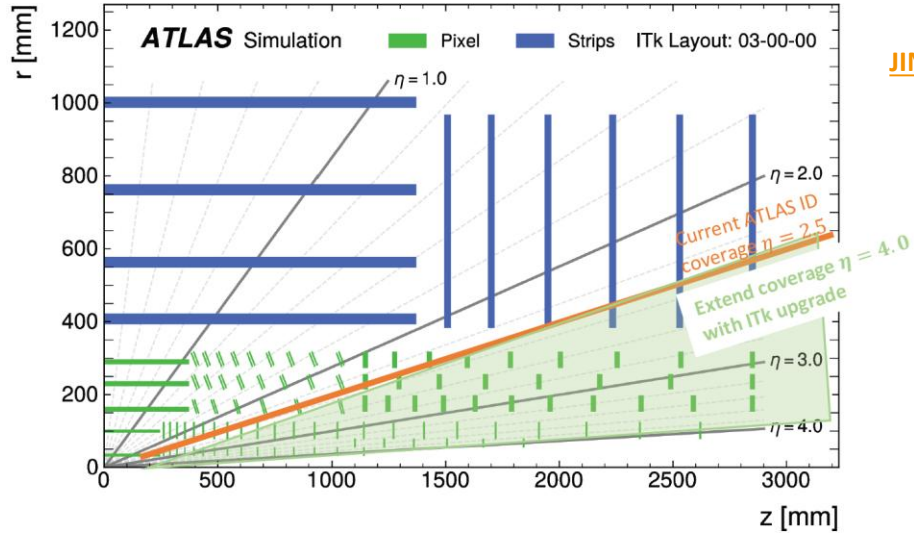

JINST 20 (2025) P02018

ITk strip detector:

- 4 barrel layers built from staves
- 6 end-cap disks built from petals
- >60 million readout channels
- Canadian institutes involved in design and construction of end-cap

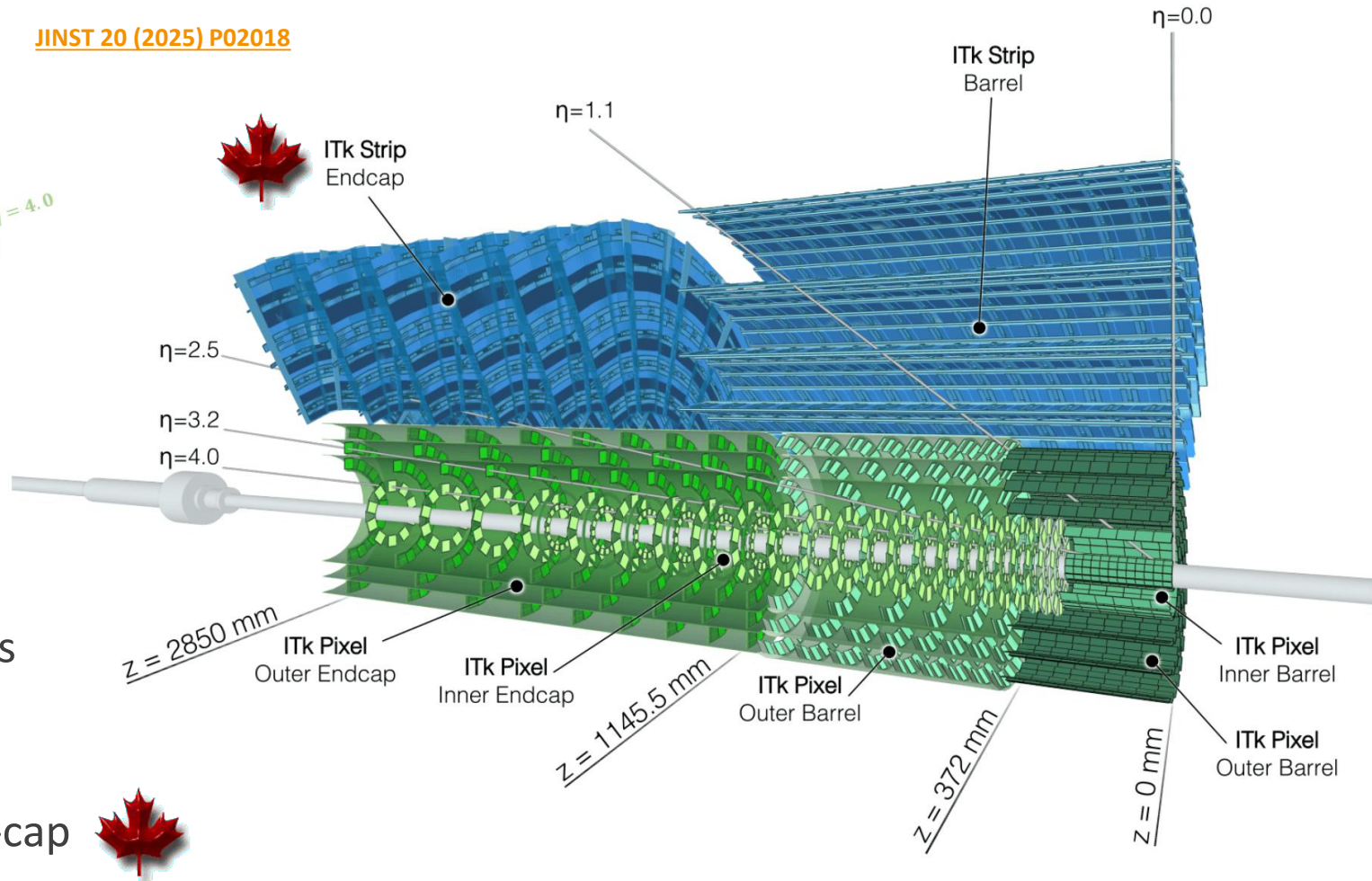



ITk Strip Modules

- strip modules consist of **hybrids** (holding readout ASICs) + **power board**, glued directly on top of **sensors**
- different barrel/end-cap flavours
 - barrel: 2560 and 5120 channels/module
 - end-cap: 2052 to 5384 channels/module
- readout strips wire-bonded to ASICs

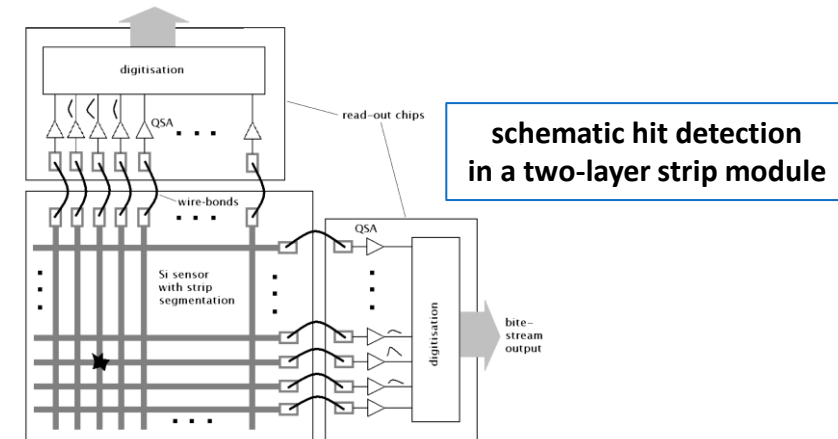
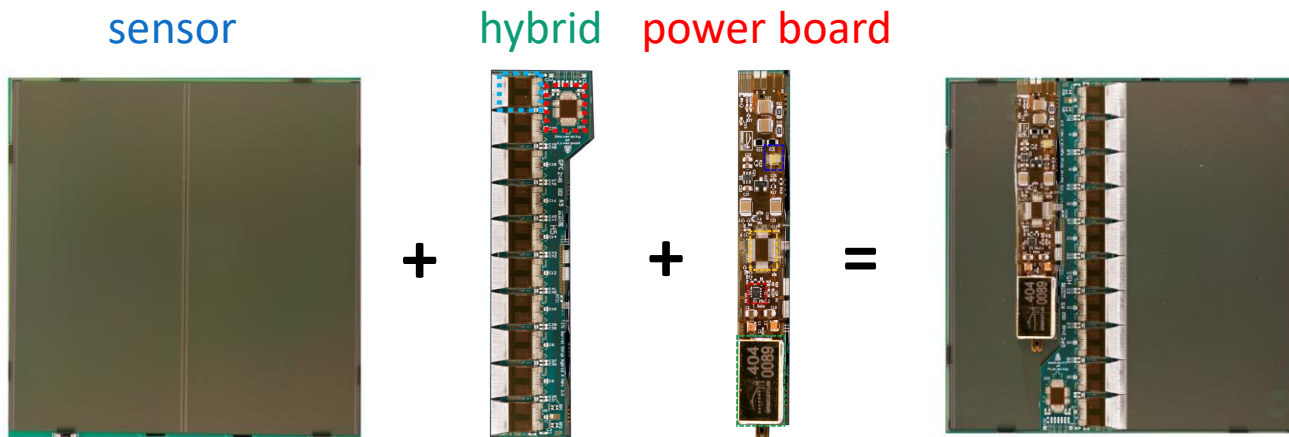
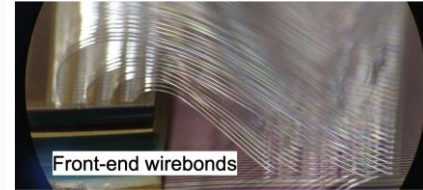
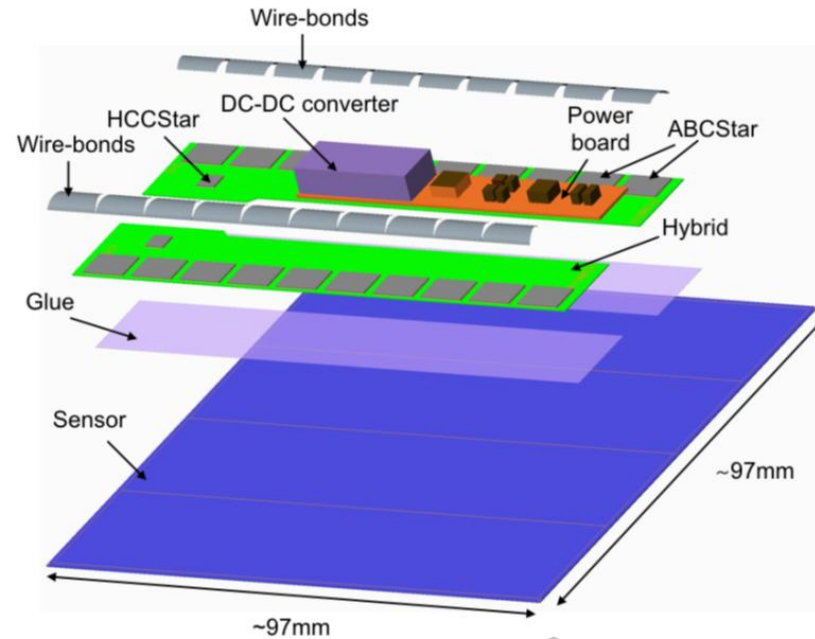



ITk Strip Sensors



- microstrip sensors designed on 320 μm thick p-type float zone wafers
- fabricated by Hamamatsu Photonics (HPK)
- n^+ -in-p design allows for
 - improved radiation tolerance (no type inversion, under-depleted operation)
 - collection of electrons instead of holes (3x higher mobility \Rightarrow improved signal)
 - single-sided processing (cheaper)

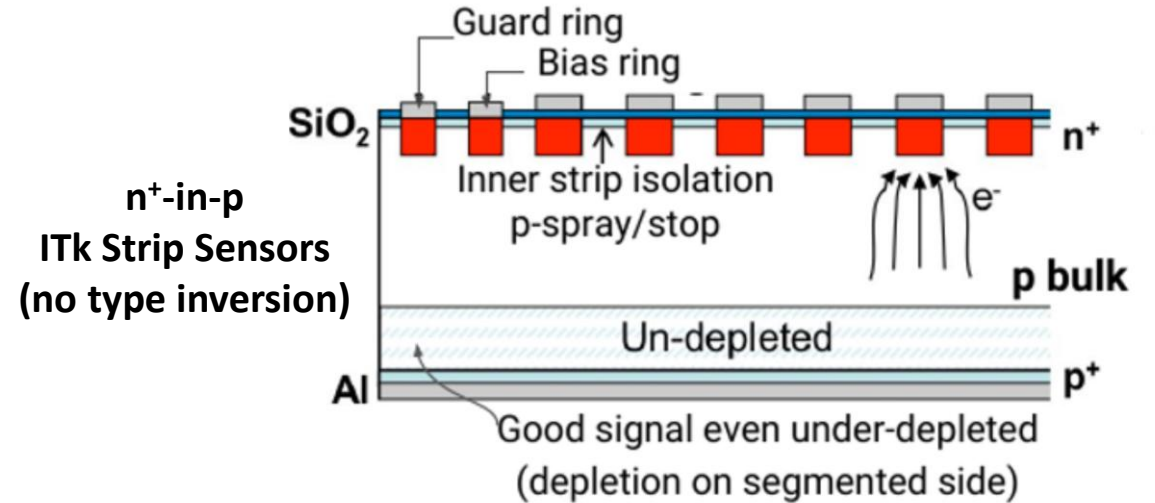

two types of **barrel** sensor designs
+ six types of **end-cap** sensor geometries

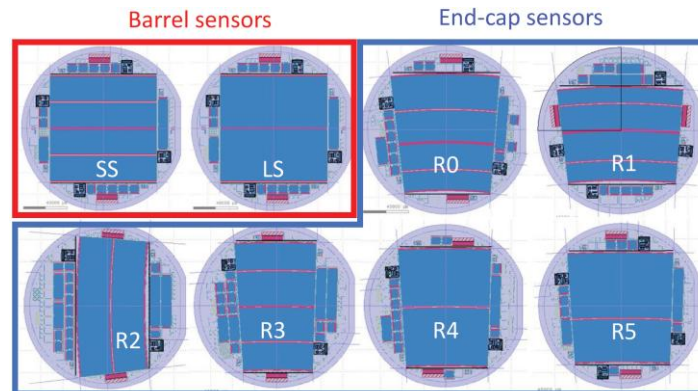

p^+ -in-n
(e.g. current SCT)

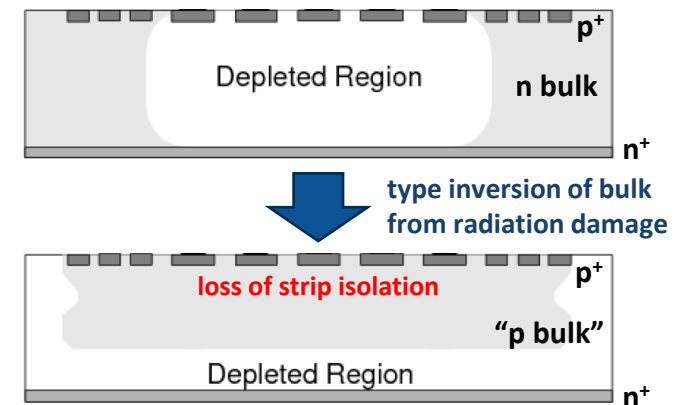

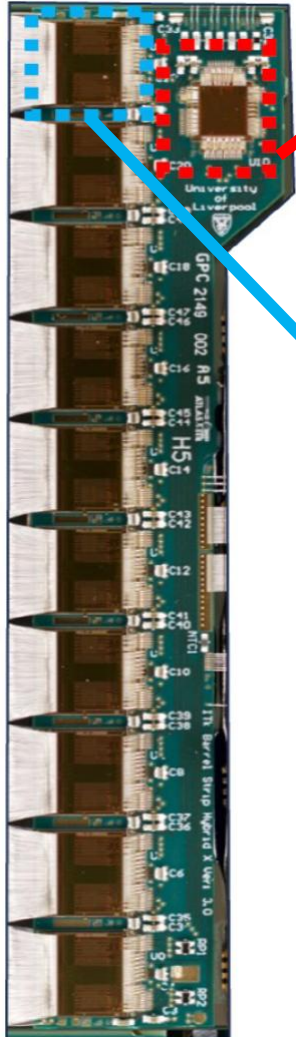

HCCStar (Hybrid Control Chip):

- distribute clock and control signals to ABCStars
- aggregate and send out data packets from ABCStars

ABCStar (ATLAS Binary Chip)

- read analog signals from sensors
- binary readout per strip
- encode hit patterns
- 256 channels/chip
- one chipset for all types of modules

- power board allows for parallel powering scheme
- bias HV filter and switch
- 11V - 1.5V DC-DC converter

AMACStar (Autonomous Monitor And Control Chip)

- all ASICs hosted on flex PCBs

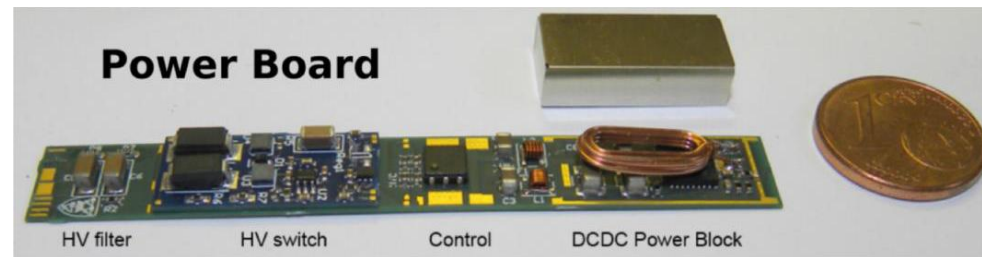
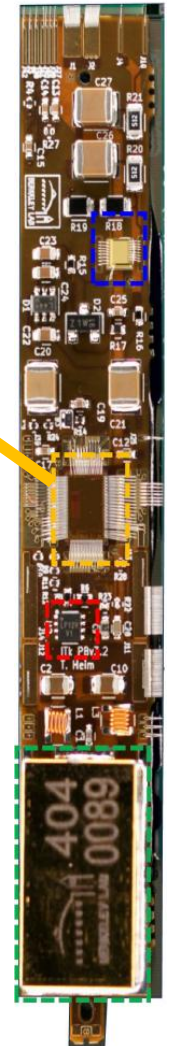



ITk Strips Supports + Mechanics



- stave and petal cores are carbon fiber structures with embedded cooling
- end-of-substructure (EoS) card links modules with off-detector systems

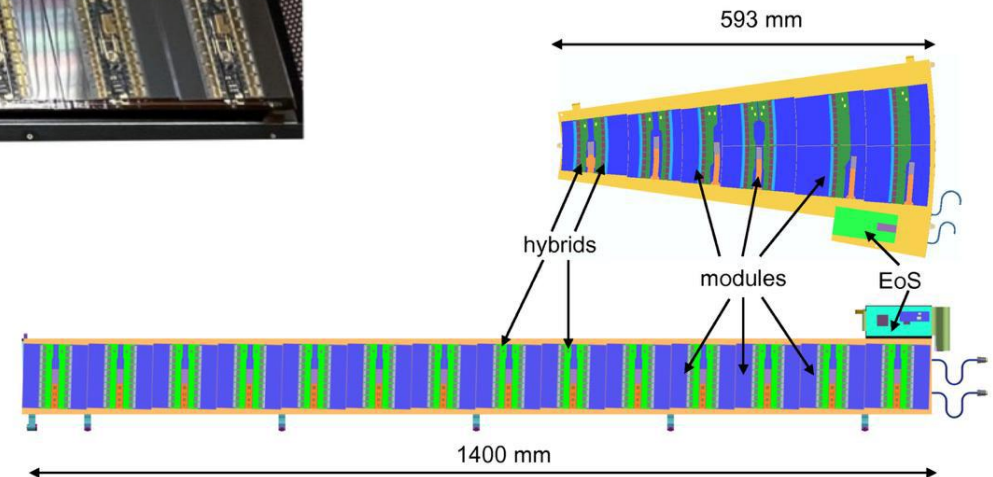
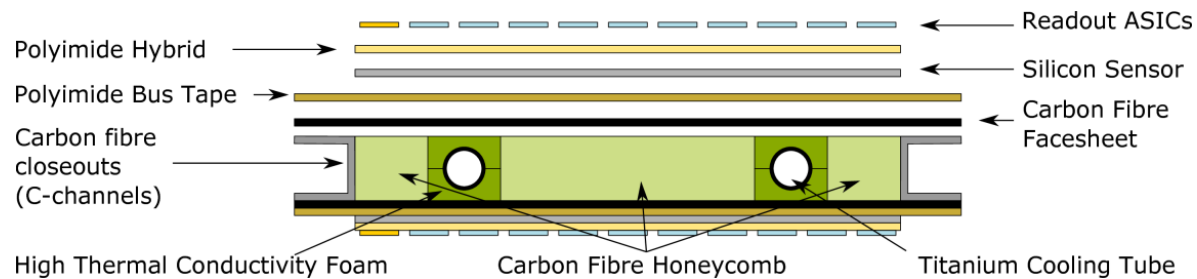
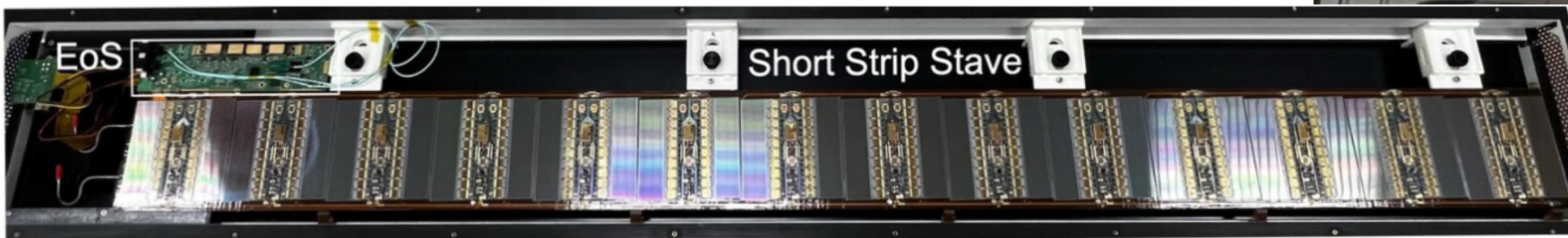
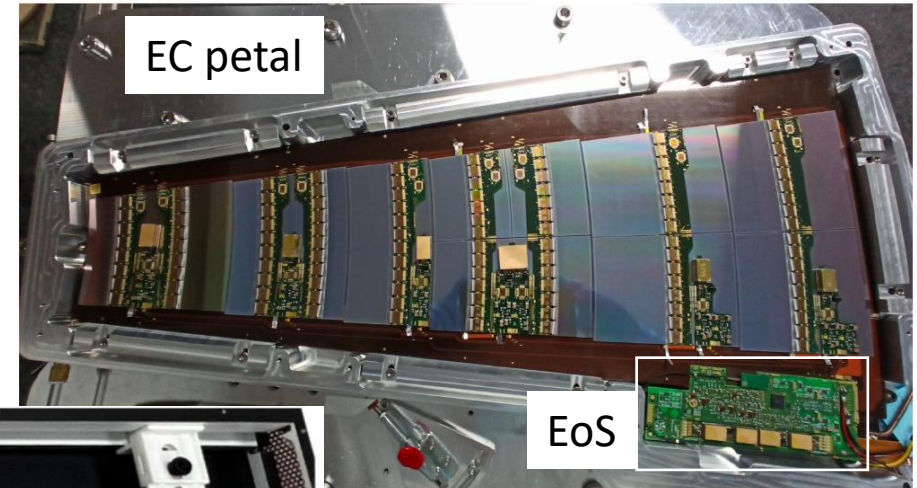
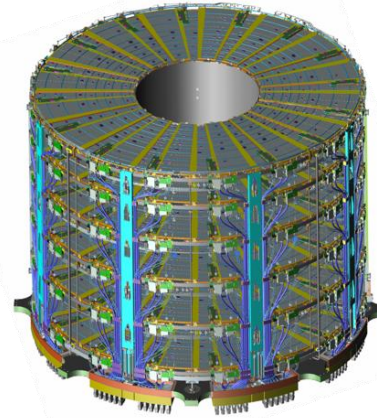



ITk Strips: Production Status



- all components have entered **production** phase
 - ASICs have finished production
 - sensors are about to finish
 - module production is ramping up
- module loading onto staves/petals has started
- move towards insertion of finished substructures into larger support structures

- collaboration has faced multiple challenges unforeseen during prototyping:
 - cold-noise
 - sensor fracturing

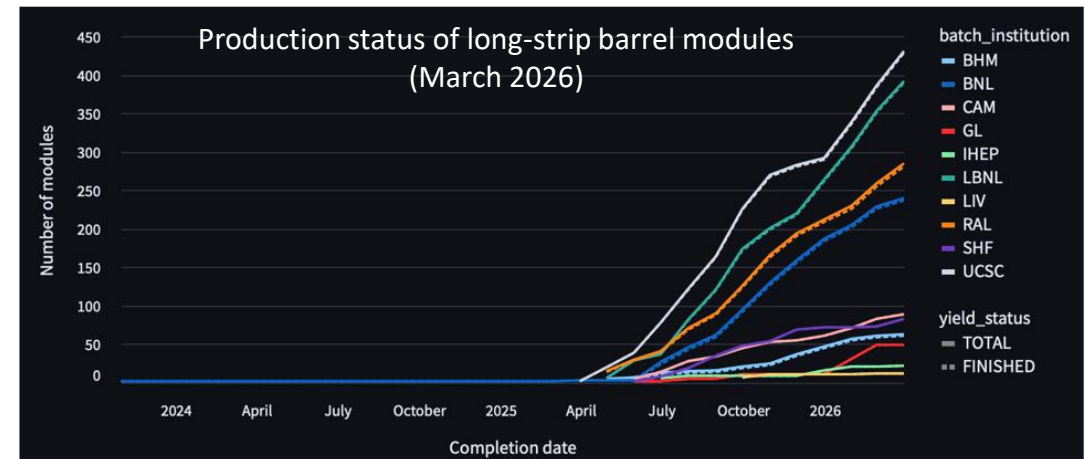
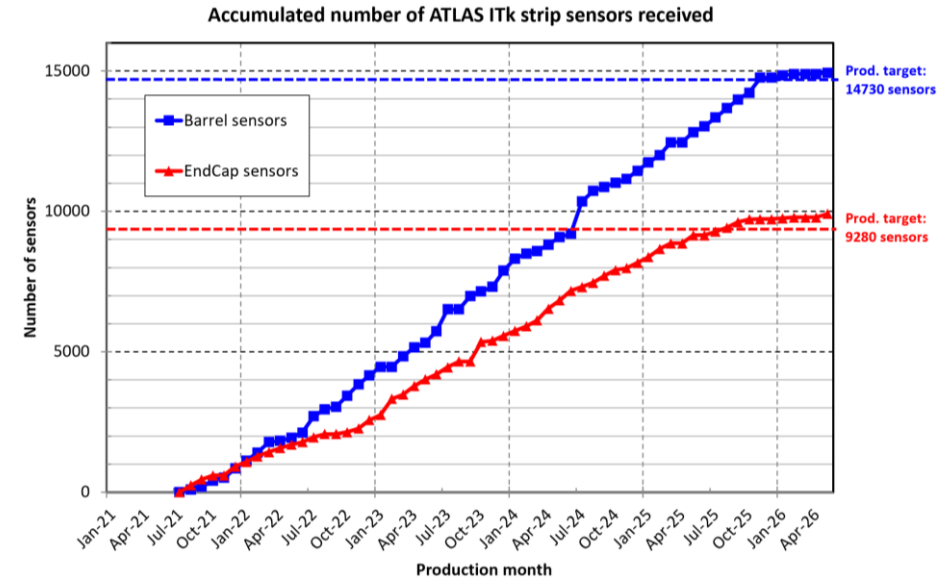



ITk Strips: Production Challenges – Sensor Fracturing

Sensor Fracturing

- cooling modules caused cracks in sensors (~15% rate)
- cause is thermal expansion coefficient (CTE) mismatch between hybrid flex, glue, and sensor

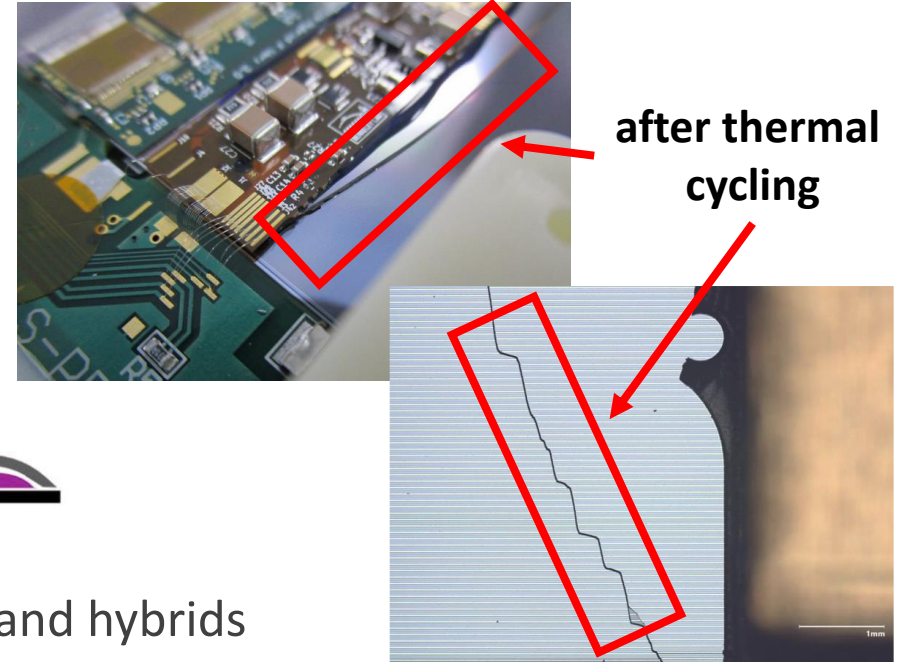

- solution: add 50 μm Kapton interposer layer between sensor and hybrids

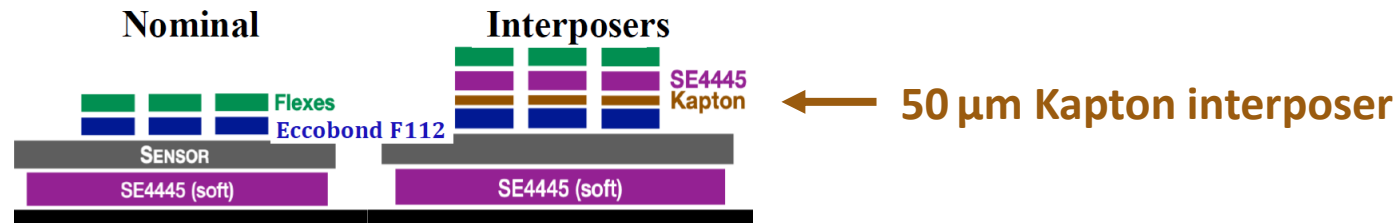

- 95% stress reduction, no more cracks, module noise not negatively affected but more complicated module assembly

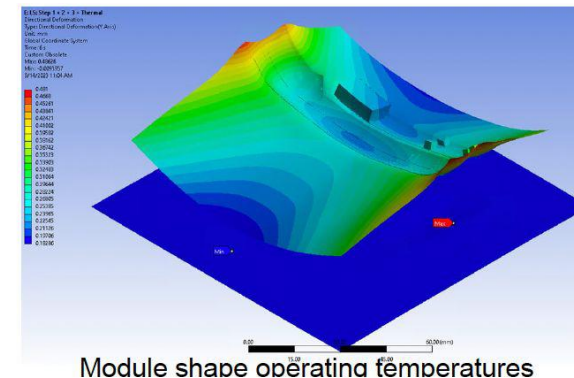



Impressions from ITk Strip Detector Production

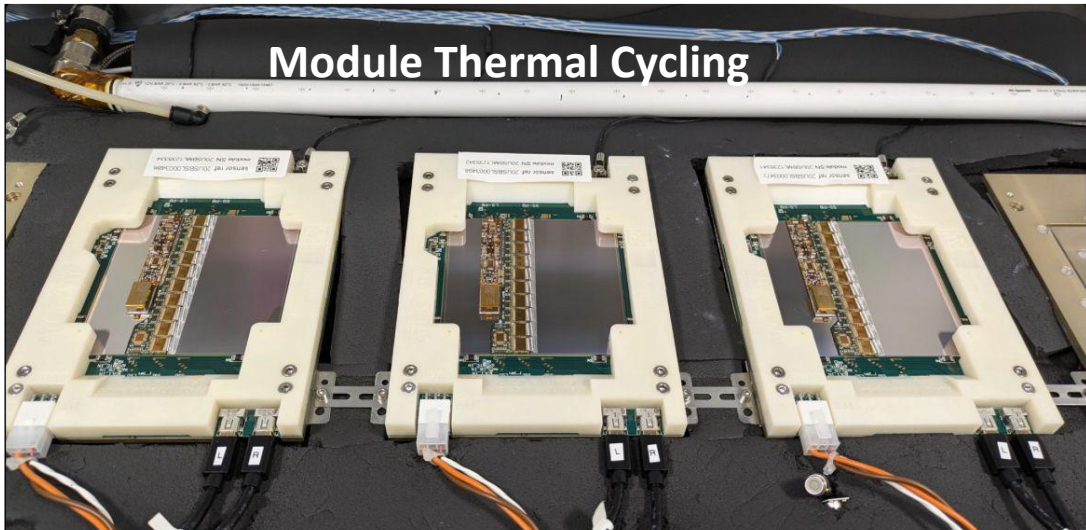

Module Thermal Cycling



Petal insertion test @DESY

Petal held by the insertion hand

Insertion arm

Insertion tower



Endcap Support



Activity Coordinator Dinner @CERN

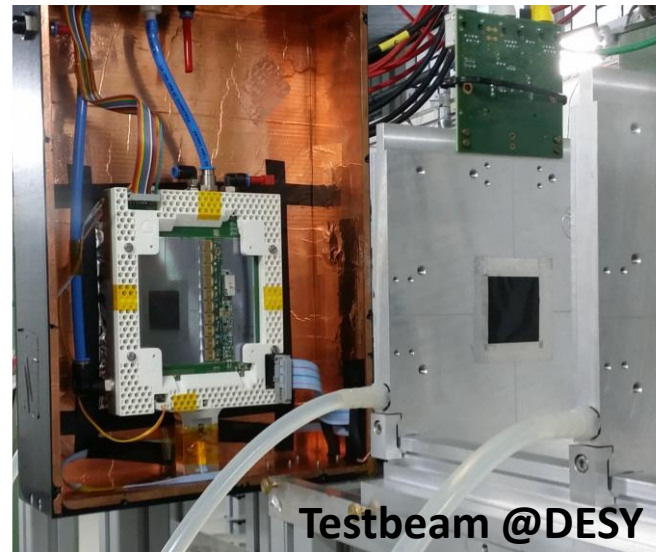

Testbeam @DESY



Stave System Testing @CERN



L3 Insertion



Summary



- ATLAS is undergoing a significant upgrade to its detector to cope with the challenging environment of the HL-LHC
 - replacing the inner detector with the all-silicon inner tracker (ITk)
 - new timing detector (HGTD) and additional muon chambers
 - replacing most readout electronics
- aim to provide improved tracking with higher pseudorapidity coverage and resolve pileup through timing measurements
- increased radiation tolerance of components
- after long R&D and pre-series phase, ITk has fully entered production
 - significant advances in all detector support activities
 - increasing focus on integration and installation
- **successful Phase-II upgrade is necessary for ATLAS to maximise the potential from the HL-LHC**

Backup



Front-End Board (FEB2) and LAr Signal Processor (LASP)



Front-End Board (FEB2)

- provide input line termination, amplification shaping, digitization, data transmission to off-detector electronics
- key ASICs:
 - preamplifier + shaper
 - ADC
 - serializer

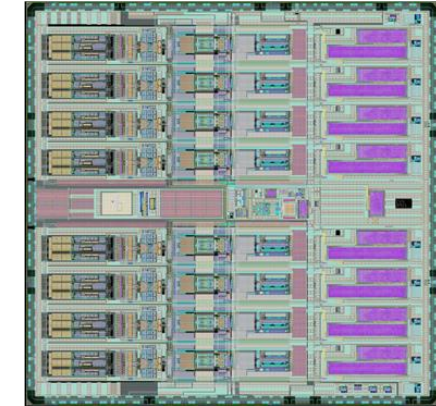
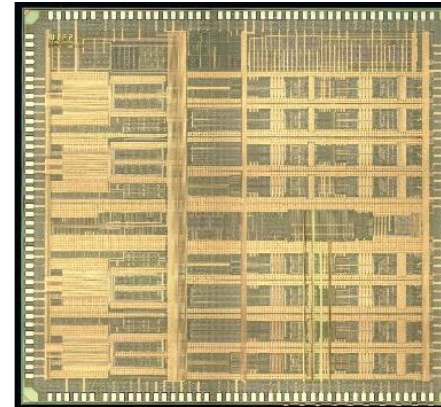

LAr Signal Processor (LASP)

- full size ATCA monolithic blade
- 8 FEBs per blade (2 FPGAs), each FPGA processes data from up to 4 FEB2s
- main challenges:
 - power and cooling
 - high speed links (L1+TDAQ) @ 25.78 Gbps
 - high density/complexity

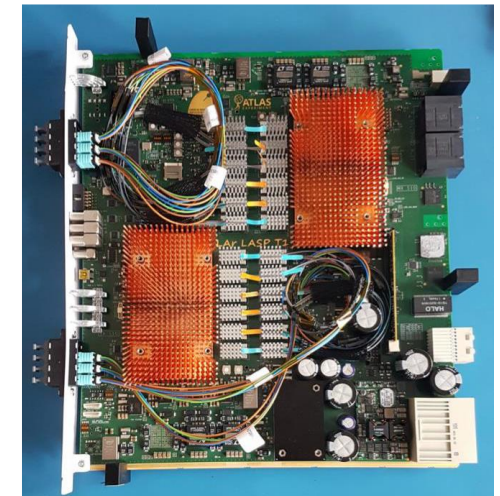
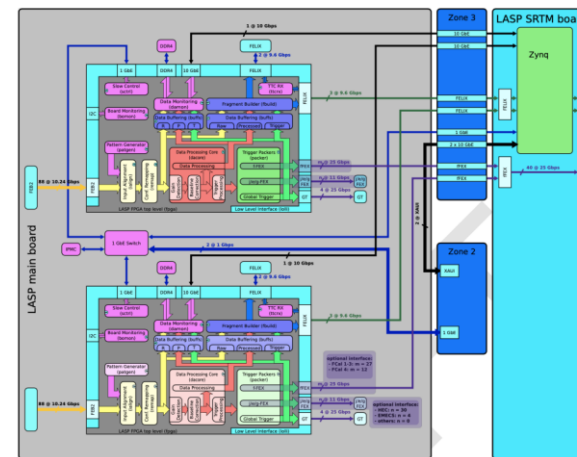



ITk Strips Detector Overview

M. Laassiri
Glasgow ATLAS Week
June 2026

Sensors ✓
24,000

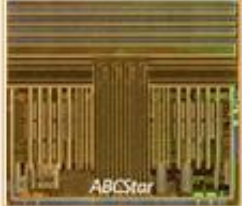
Chips ✓
233,856 25,536 17,904







ABCStar Front-end chip Binary readout 	HCCStar On-hybrid digital Interface chip 	AMACStar On-module monitoring and control chip 
---	--	--

Modules

Barrel
10,976 mod w/
2 full mod types

Endcap
2 x 2,352 mod w/
6 full mod types

	
7,168 LS mod	3,808 SS mod

		
R0	R1	R2
		
R3	R4	R5

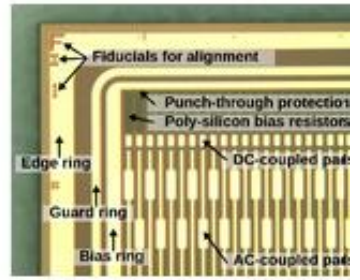

Hamamatsu Sensors

- 320 um thick
- n-in-p Si

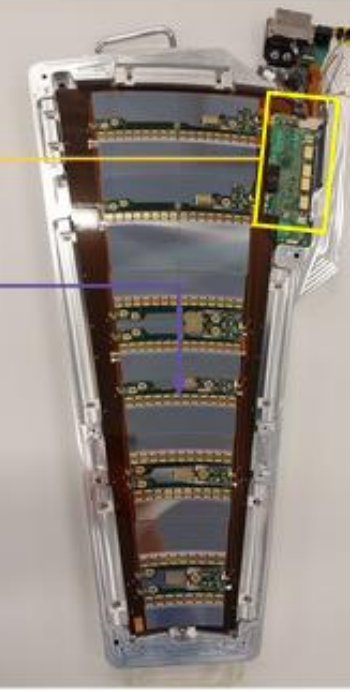

Petals
2 x 192

Staves
392

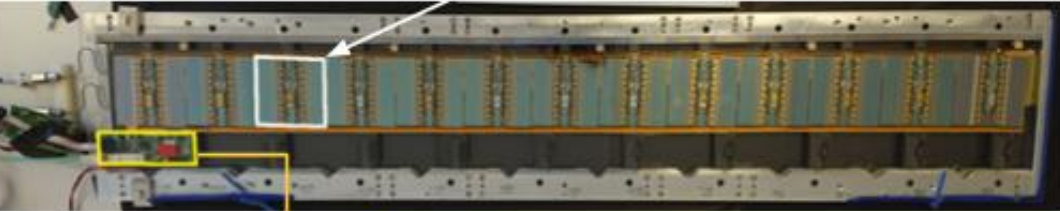

End Of Substructure (EOS) card
IpGBT VTRx+



ITk Strip Module Readout Chain

