

A Search For Emerging Jets In ATLAS Run 2 Data



JÉRÉMIE LEPAGE-BOURBONNAIS

CAP CONGRESS 2026

ATLAS Detector

General purpose detector located at the LHC

Observes high energy proton-proton and heavy ion collisions

Layered detector design:

- Inner detectors reconstruct tracks from charged particles
- Calorimeters measure particle energies
- Muon spectrometers record muon momentum

Maximized coverage around the collision point

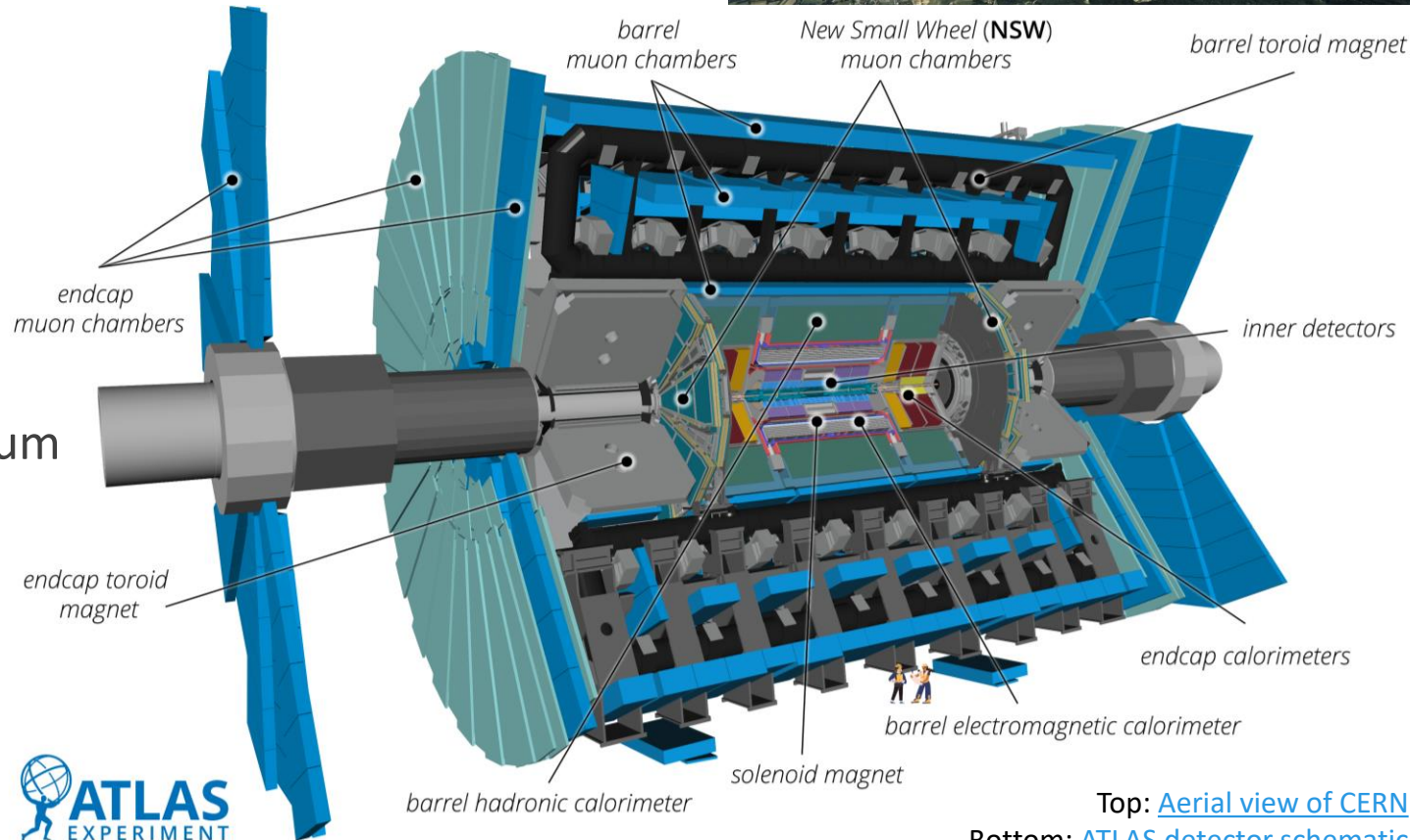

Particle Jets

Jets are collections of particles clustered together to recreate the spray of partons produced after the initial collision

They are used by most ATLAS analyses and are the most common product of collisions

High energy quarks and gluons undergo hadronization to produce longer-lived particles

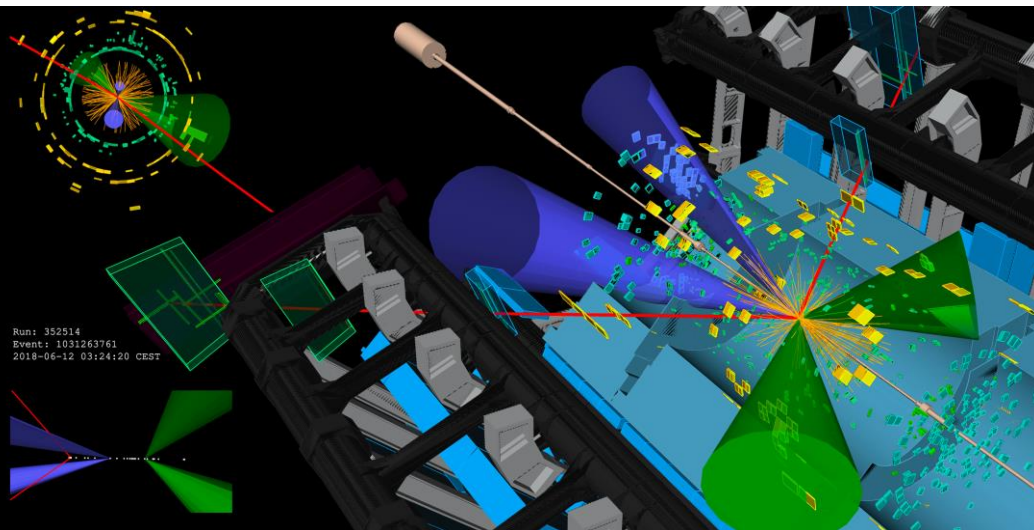

ATLAS Event Display, [ATLAS Experiment](#)

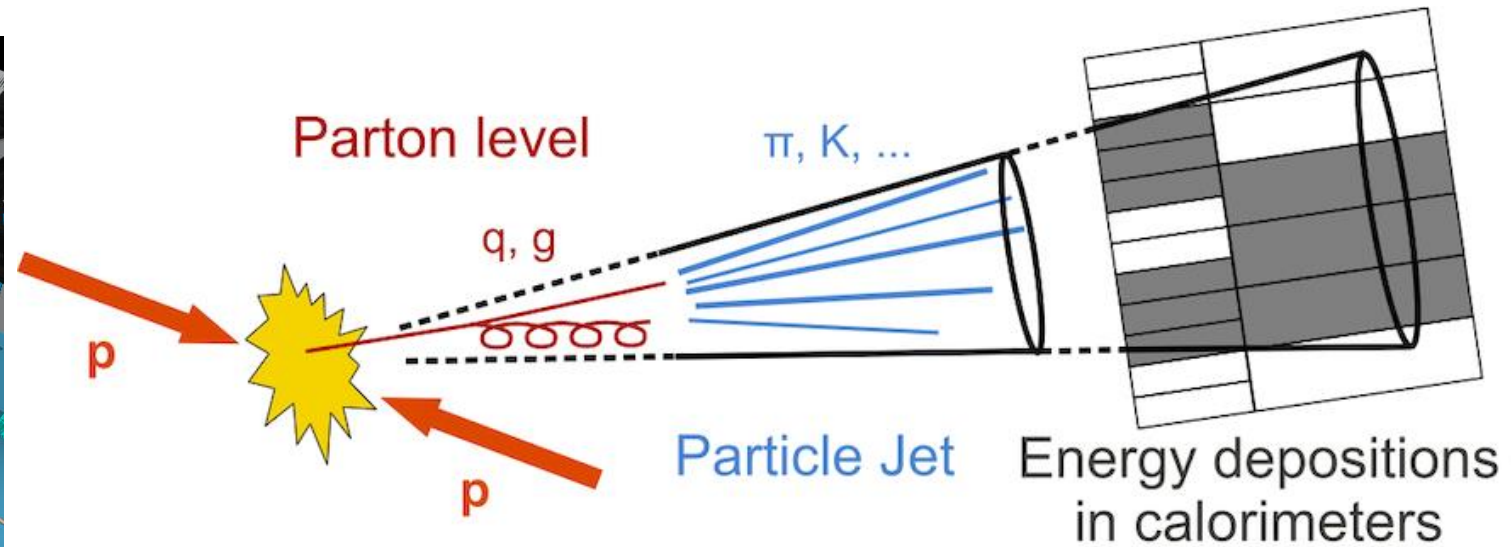

Diagram of a jet in ATLAS, [ATLAS Experiment](#)

The Emerging Jets Model

Investigates a dark QCD-like Hidden Valley expansion to the Standard Model

Features dark analogues to QCD particles

The lightest dark baryon is stable and is a dark matter candidate

The lightest meson (π_d) eventually decays back into the SM
 ATLAS Collisions could produce two scalar mediators (ϕ)

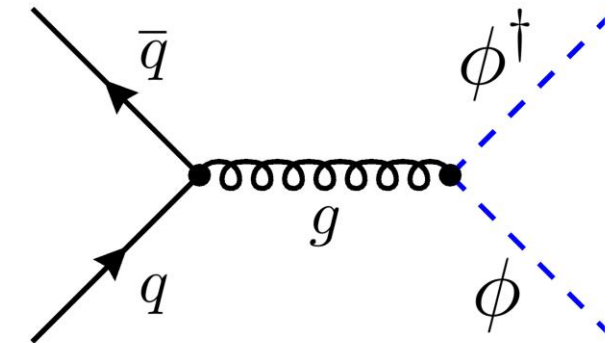

The Emerging Jets Model

Investigates a dark QCD-like Hidden Valley expansion to the Standard Model

Features dark analogues to QCD particles

The lightest dark baryon is stable and is a dark matter candidate

The lightest meson (π_d) eventually decays back into the SM
 ATLAS Collisions could produce two scalar mediators (ϕ)

The mediators decay to a SM and dark quark

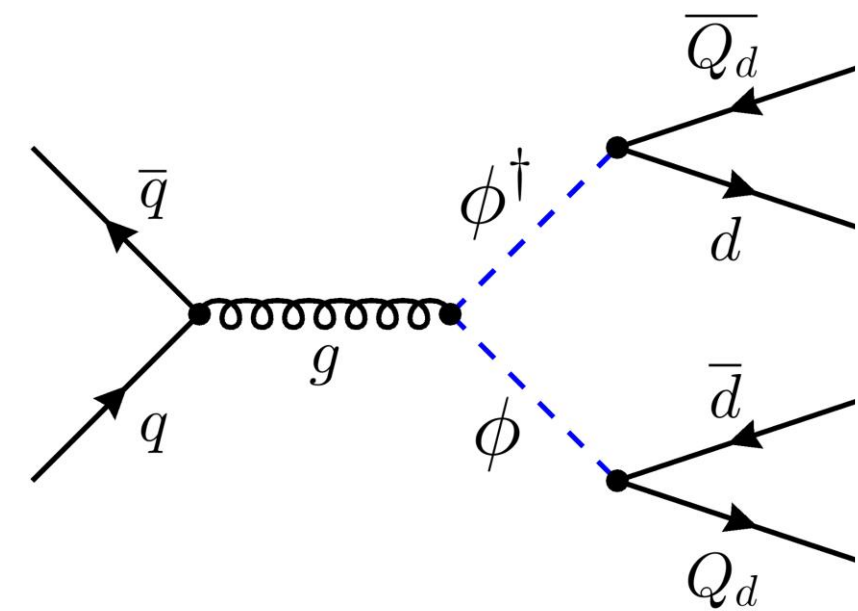

The Emerging Jets Model

Investigates a dark QCD-like Hidden Valley expansion to the Standard Model

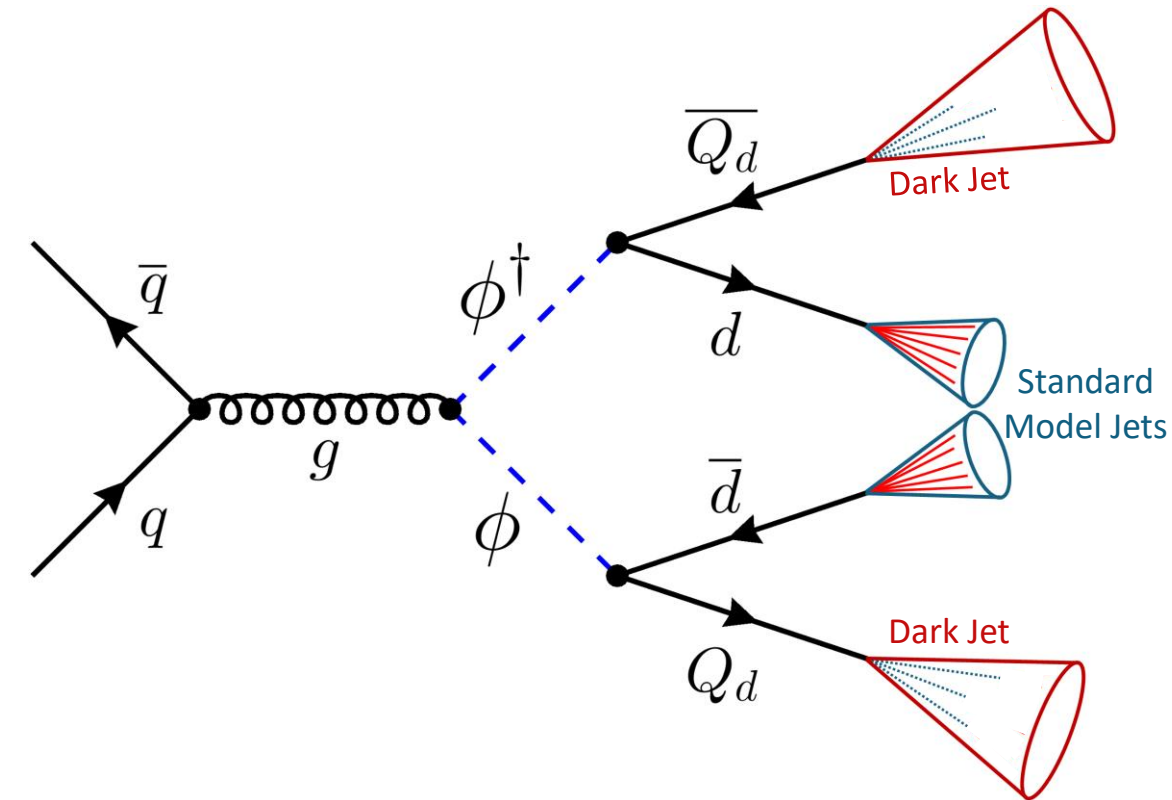

Features dark analogues to QCD particles

The lightest dark baryon is stable and is a dark matter candidate

The lightest meson (π_d) eventually decays back into the SM

ATLAS Collisions could produce two scalar mediators

The mediators decay to a SM and dark quark

Both quarks produce jets in their respective sectors

The Emerging Jets Model

Investigates a dark QCD-like Hidden Valley expansion to the Standard Model

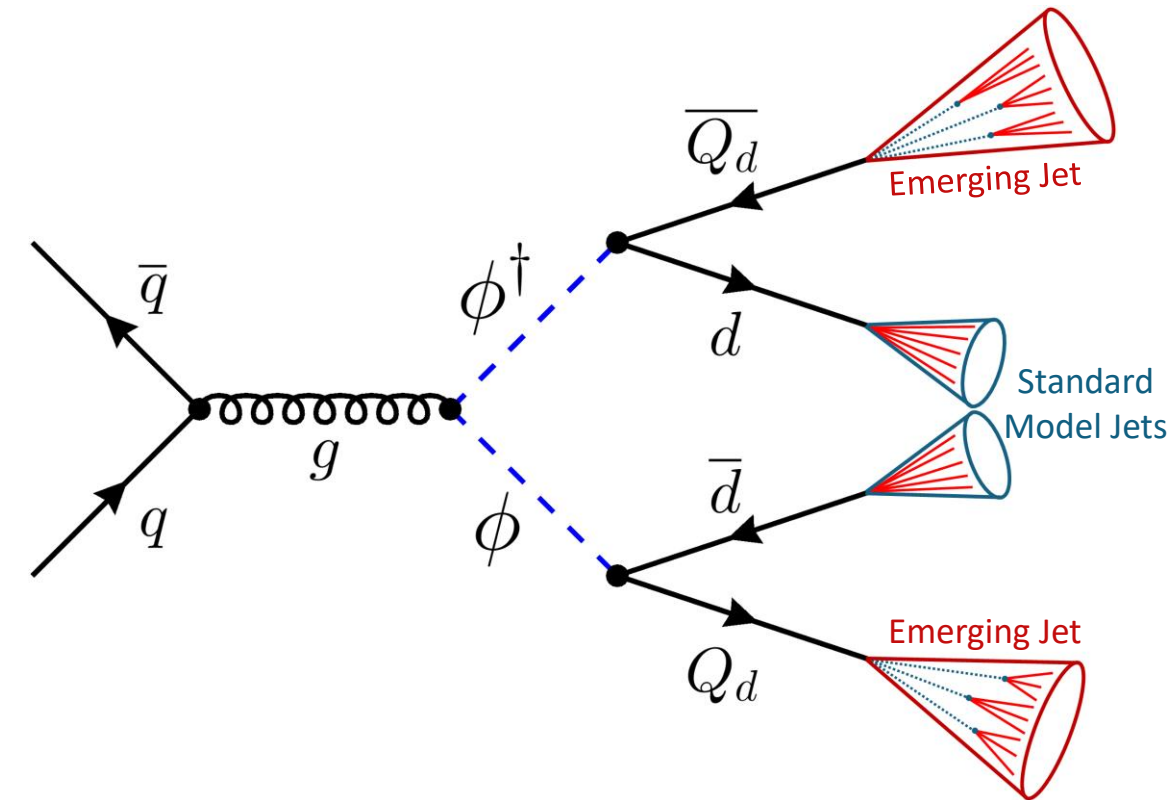

Features dark analogues to QCD particles

The lightest dark baryon is stable and is a dark matter candidate

The lightest meson (π_d) eventually decays back into the SM

ATLAS Collisions could produce two scalar mediators

The mediators decay to a SM and dark quark

Both quarks produce jets in their respective sectors

Dark jets would be invisible at first, and then become visible as the dark pions travel through the detector and decay

These jets would thus 'emerge' into the detectors

The Emerging Jets Model

Investigates a dark QCD-like Hidden Valley expansion to the Standard Model

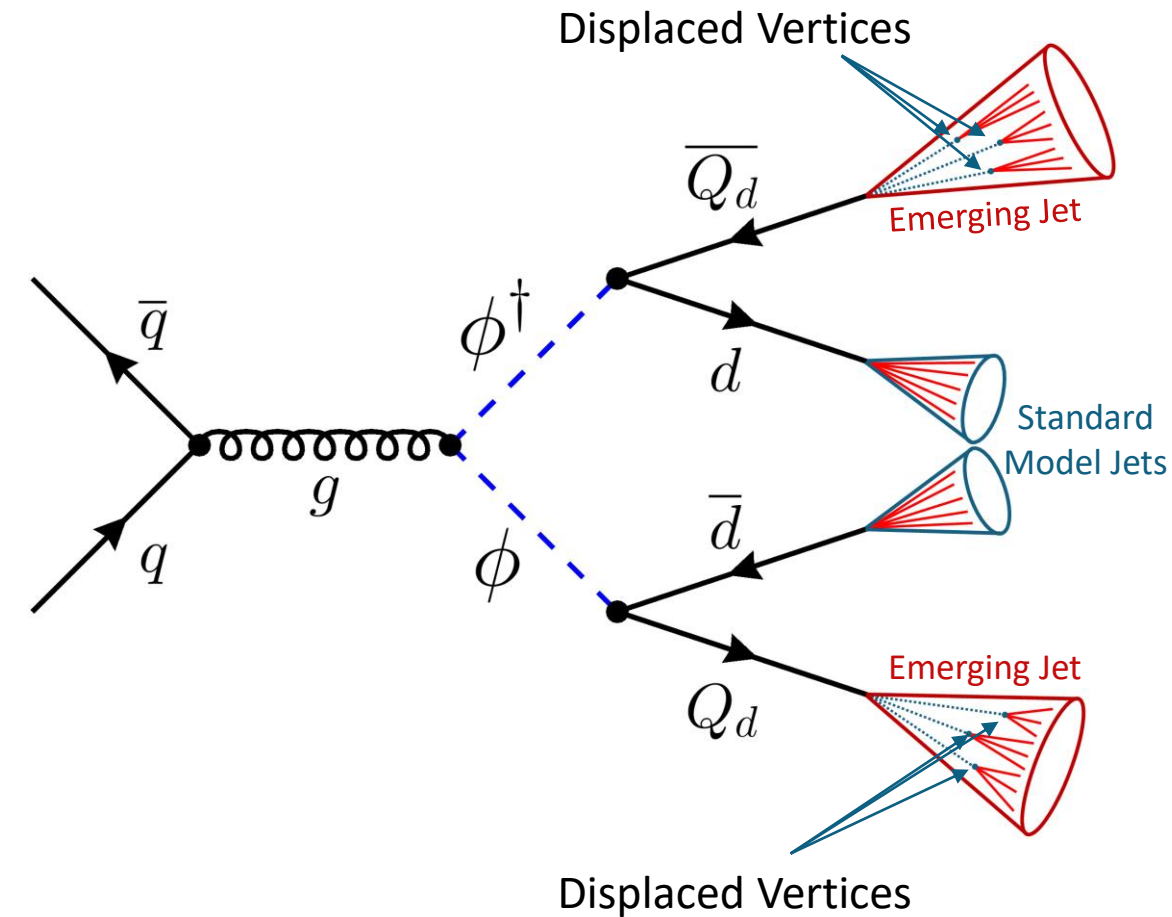

Features dark analogues to QCD particles

The lightest dark baryon is stable and is a dark matter candidate

The lightest meson (π_d) eventually decays back into the SM

ATLAS Collisions could produce two scalar mediators

The mediators decay to a SM and dark quark

Both quarks produce jets in their respective sectors

Dark jets would be invisible at first, and then become visible as the dark pions travel through the detector and decay

These jets would thus 'emerge' into the detectors

Signal Models

Parameter space defined by **mediator mass**, **dark pion mass**, and **dark pion lifetime**

Total of 162 Monte Carlo samples

General Trends:

- Number of displaced vertices increases with higher mediator mass
- Number of displaced vertices decreases with higher dark pion mass
- Short lifetimes look more SM-like, large lifetimes are less visible to the detector

Mediator Mass (M_ϕ)	1.0 - 2.2 TeV
Dark Pion Mass (m_{π_d})	5, 10, 20 GeV
Dark Pion Lifetime ($c\tau_{\pi_d}$)	1 – 1000 mm

Key Analysis Variables

Emerging jet tracks will be initially invisible

PTF: Ratio of initial track and total momentum

- Emerging jets will have low PTF
- Use minimum PTF of the 4 highest momentum jets in an event

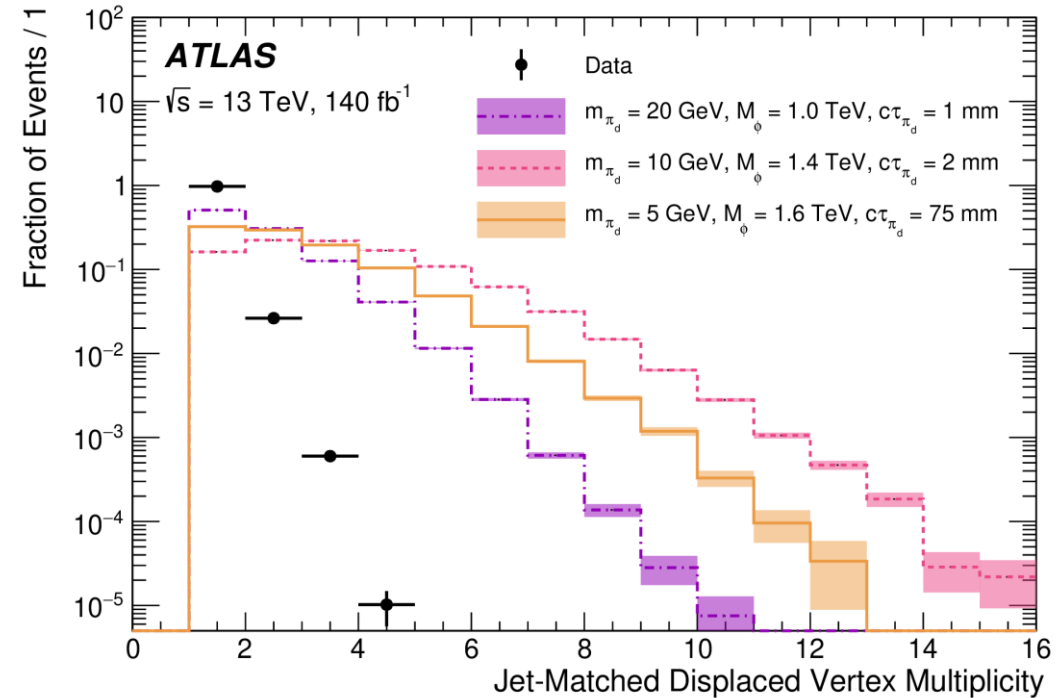
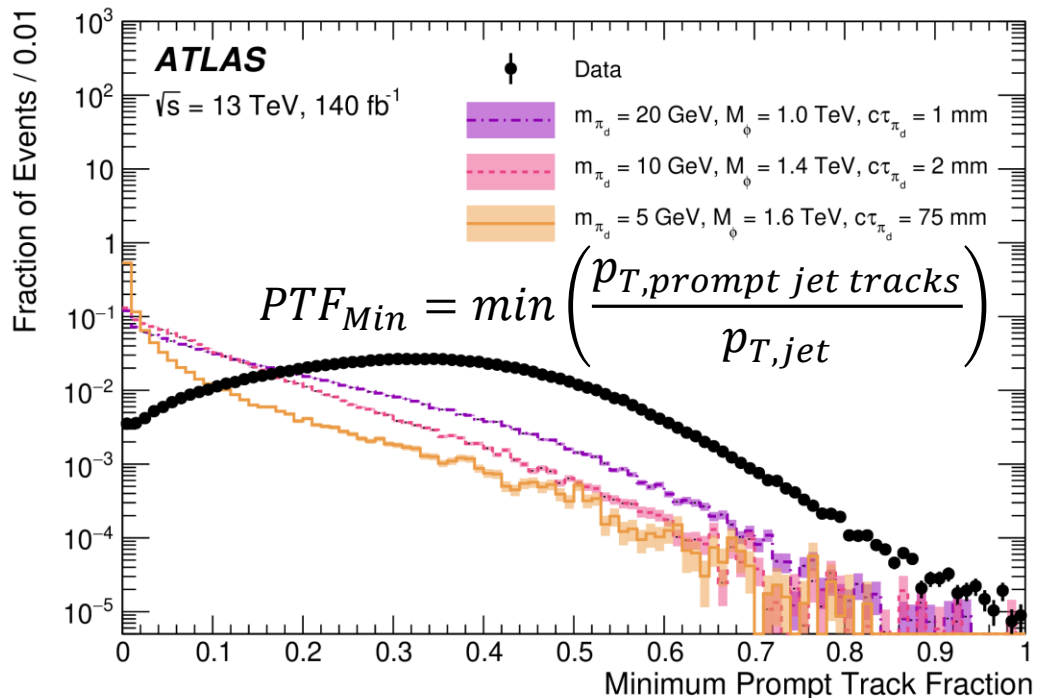

Dark pion decays produce visible tracks

Displaced vertices are formed from combining these tracks

Emerging jet events will have many displaced vertices

Two-Level Boosted Decision Trees

Train two BDTs, one on individual jets and one on whole events

Jet-Level: Characterizes how ‘emerging’ a jet is

- Uses jet kinematics and width

Event-Level: Uses jet-level BDT response alongside additional key variables

- Uses Jet-Level BDT response of 4 highest momentum jets and the scalar sum of their transverse momentum
- Additionally uses the minPTF, total number of jets, and event sphericity

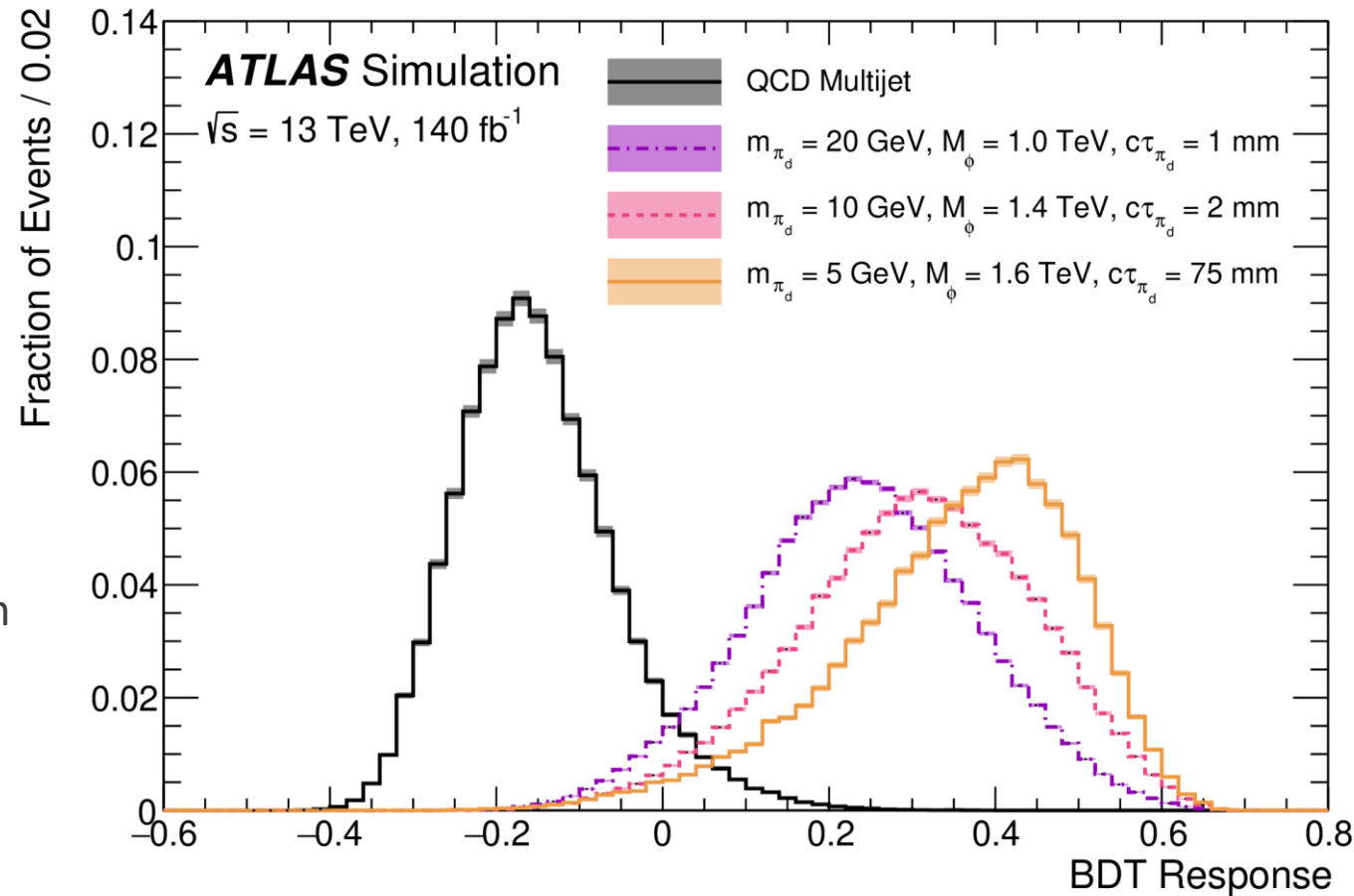

ABCD Data Driven Background Estimation

Estimates background count in the signal region

$$N_A^{Bkg} = N_B^{Bkg} \frac{N_C^{Bkg}}{N_D^{Bkg}}$$

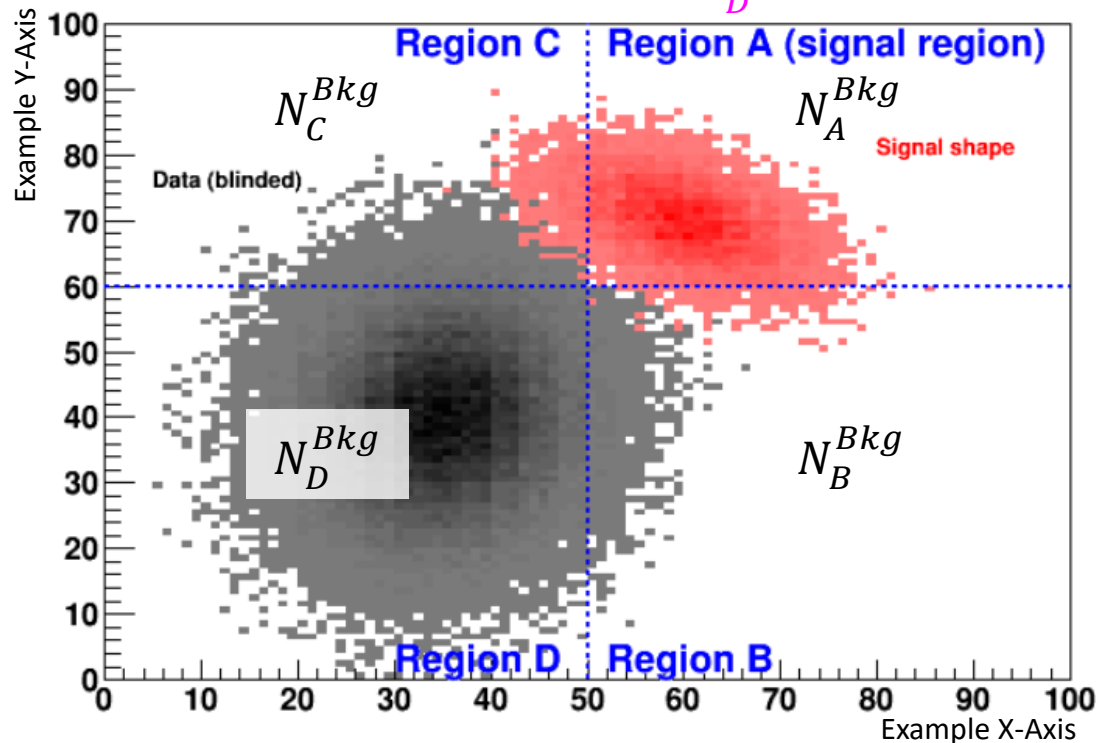

Assumes uncorrelated background with negligible signal contamination in regions B, C, & D

ABCD Plane Example, [Background Estimation With The ABCD Method](#)

ABCD Data Driven Background Estimation

Estimates background count in the signal region

$$N_A^{Bkg} = N_B^{Bkg} \frac{N_C^{Bkg}}{N_D^{Bkg}}$$

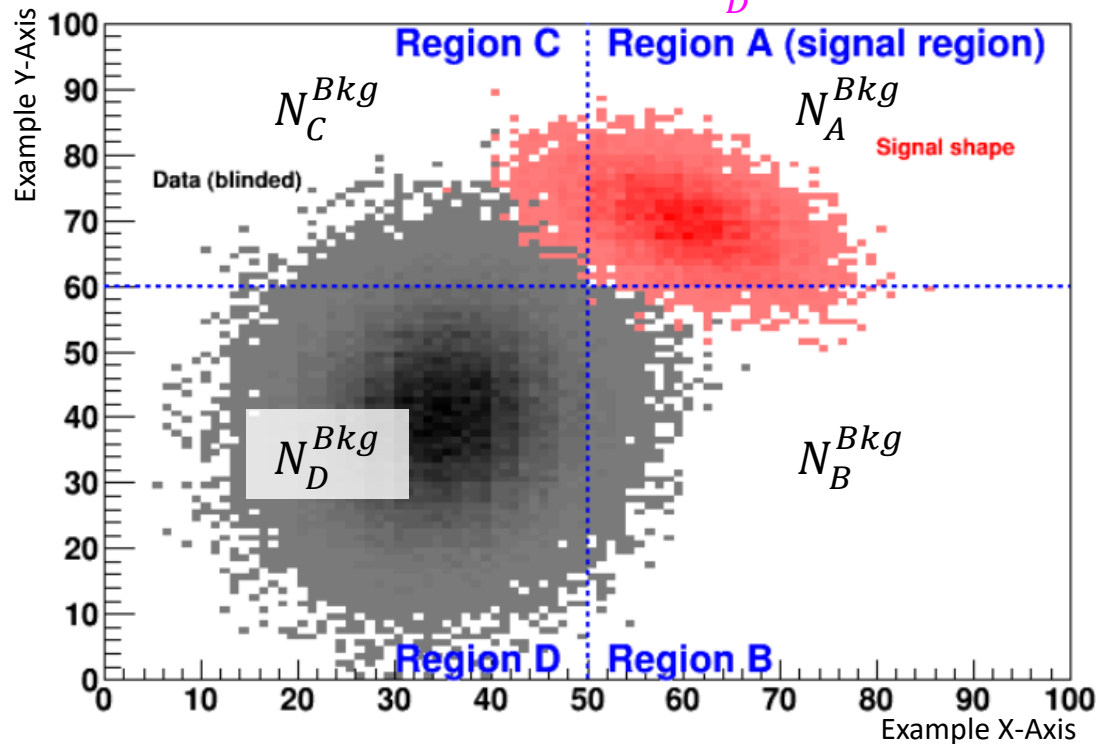

Assumes uncorrelated background with negligible signal contamination in regions B, C, & D

ABCD Plane Example, [Background Estimation With The ABCD Method](#)

Linear extrapolation accounts for correlation

$$N_{A,bin}^{Bkg} = (p_0 + p_1 R_{BDT}) N_{B,bin}^{Bkg}$$

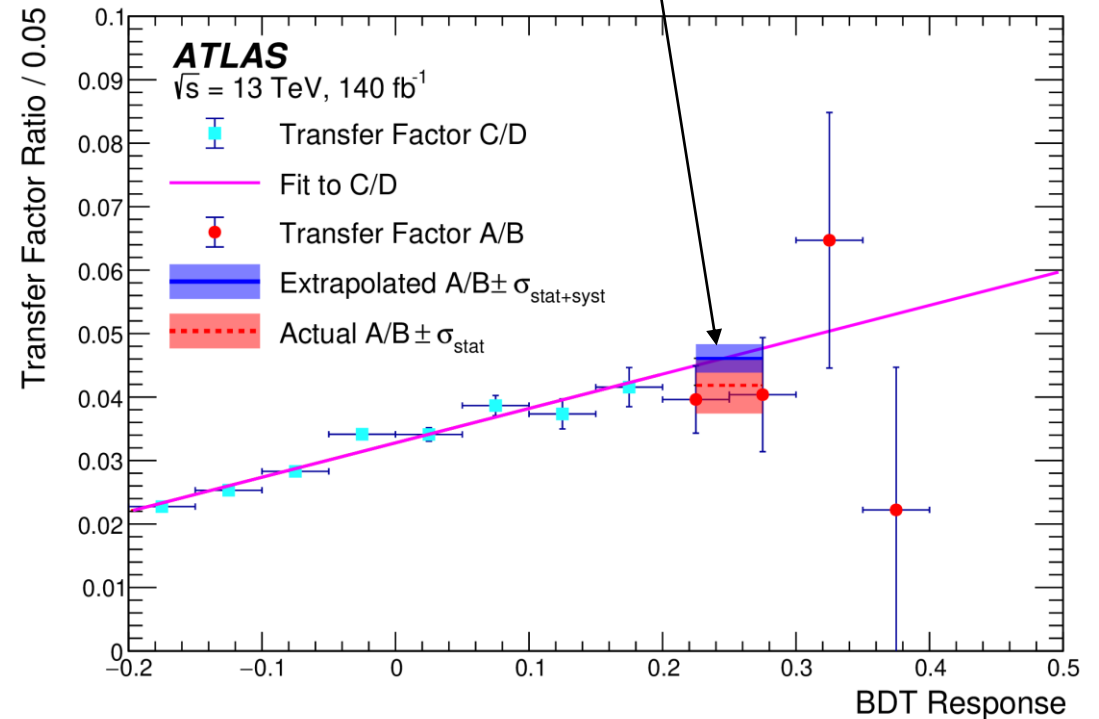

Full fits also account for potential signal contamination

ABCD Data Driven Background Estimation

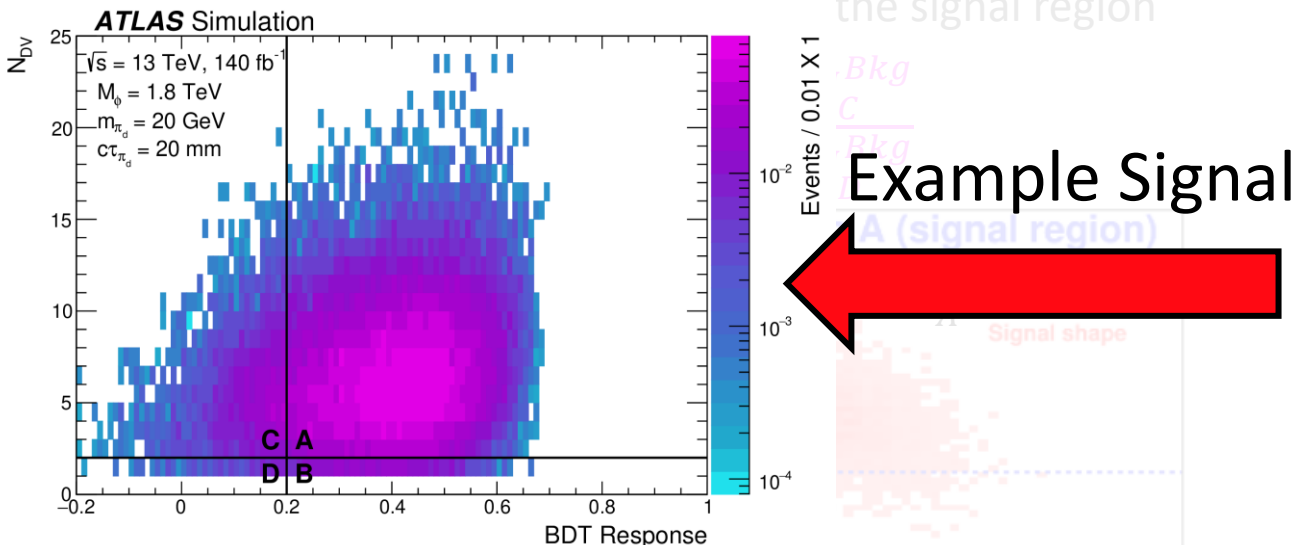

Linear extrapolation accounts for correlation

$$N_{A,bin}^{Bkg} = (p_0 + p_1 R_{BDT}) N_{B,bin}^{Bkg}$$

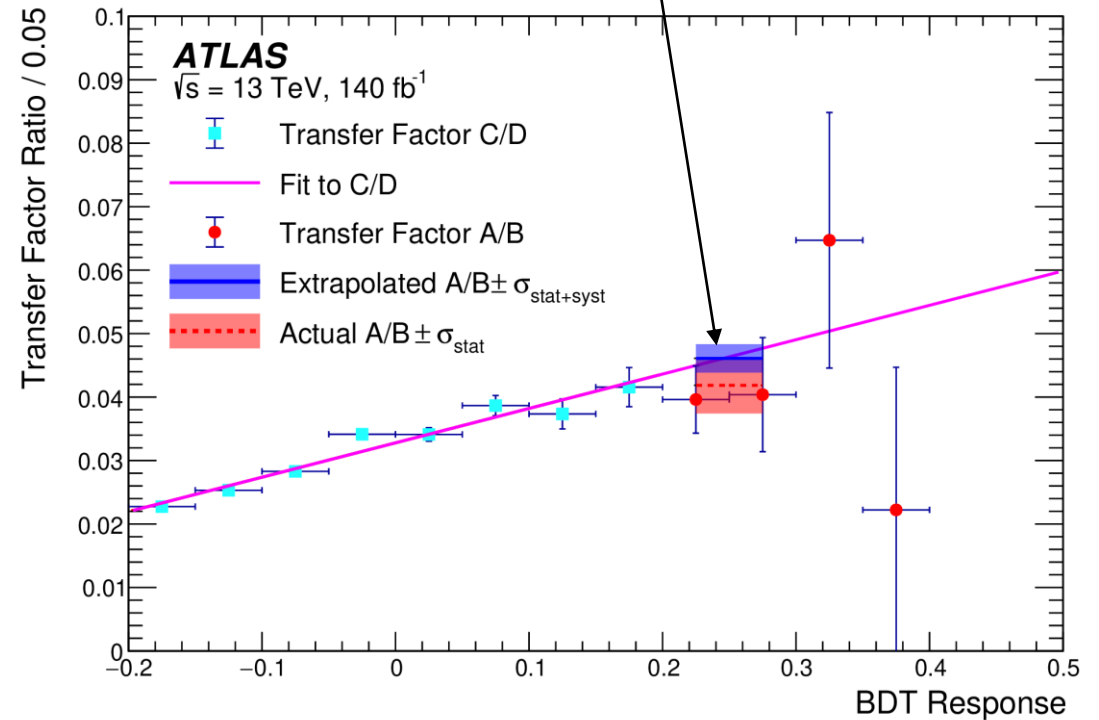

Full fits also account for potential signal contamination

Run 2 Data

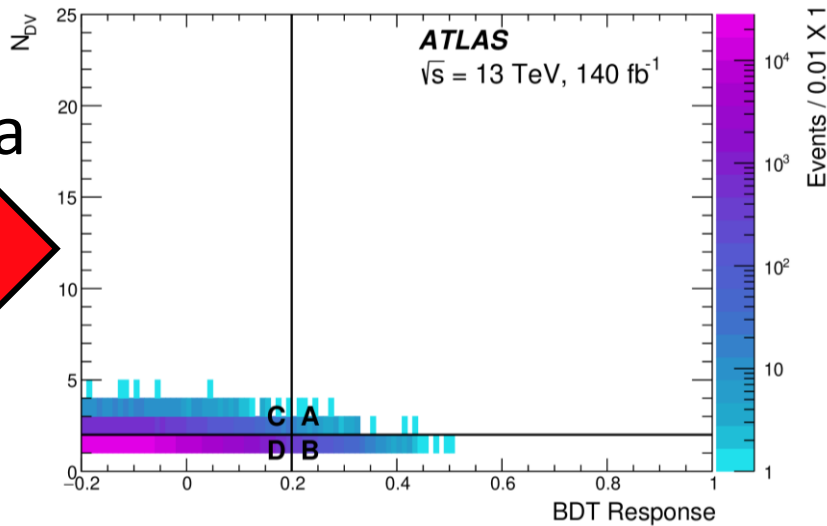

Assumes uncorrelated background

Emerging Jets ABCD Plane And Results

X-Axis: Event BDT Response

Y-Axis: Number of displaced vertices

Separate fits performed for all 162 models

Did not find evidence of emerging jets

Background overestimated but consistent with observed counts

Event Yield in the SR	
Prediction	112 ± 6 (stat.) ± 4 (syst.)
Observed Yield	103

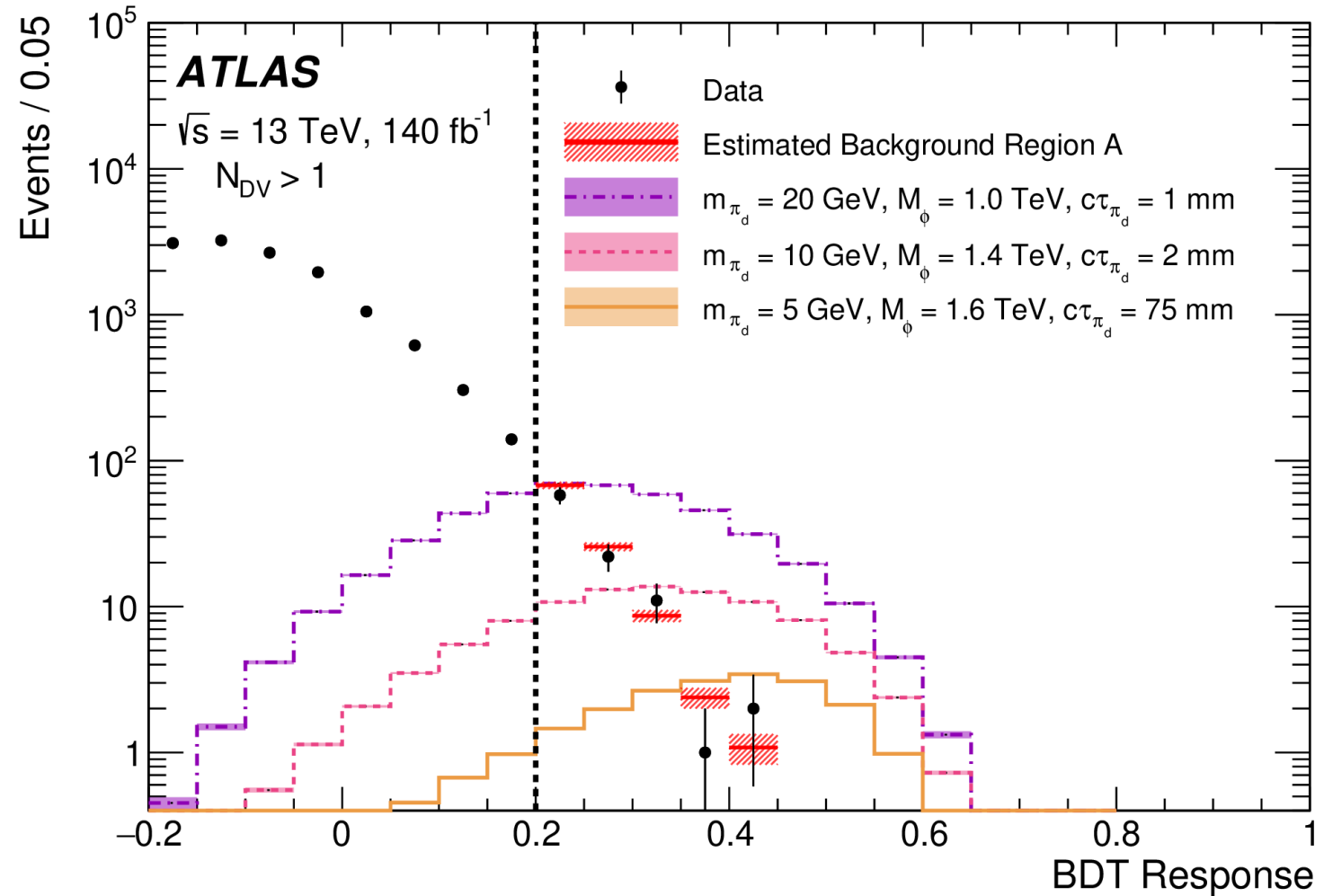

Cross-section Limits

95% confidence upper limits on cross-sections

Strongest limits achieved for intermediate π_d lifetimes

Region to the left of the limit curves is excluded

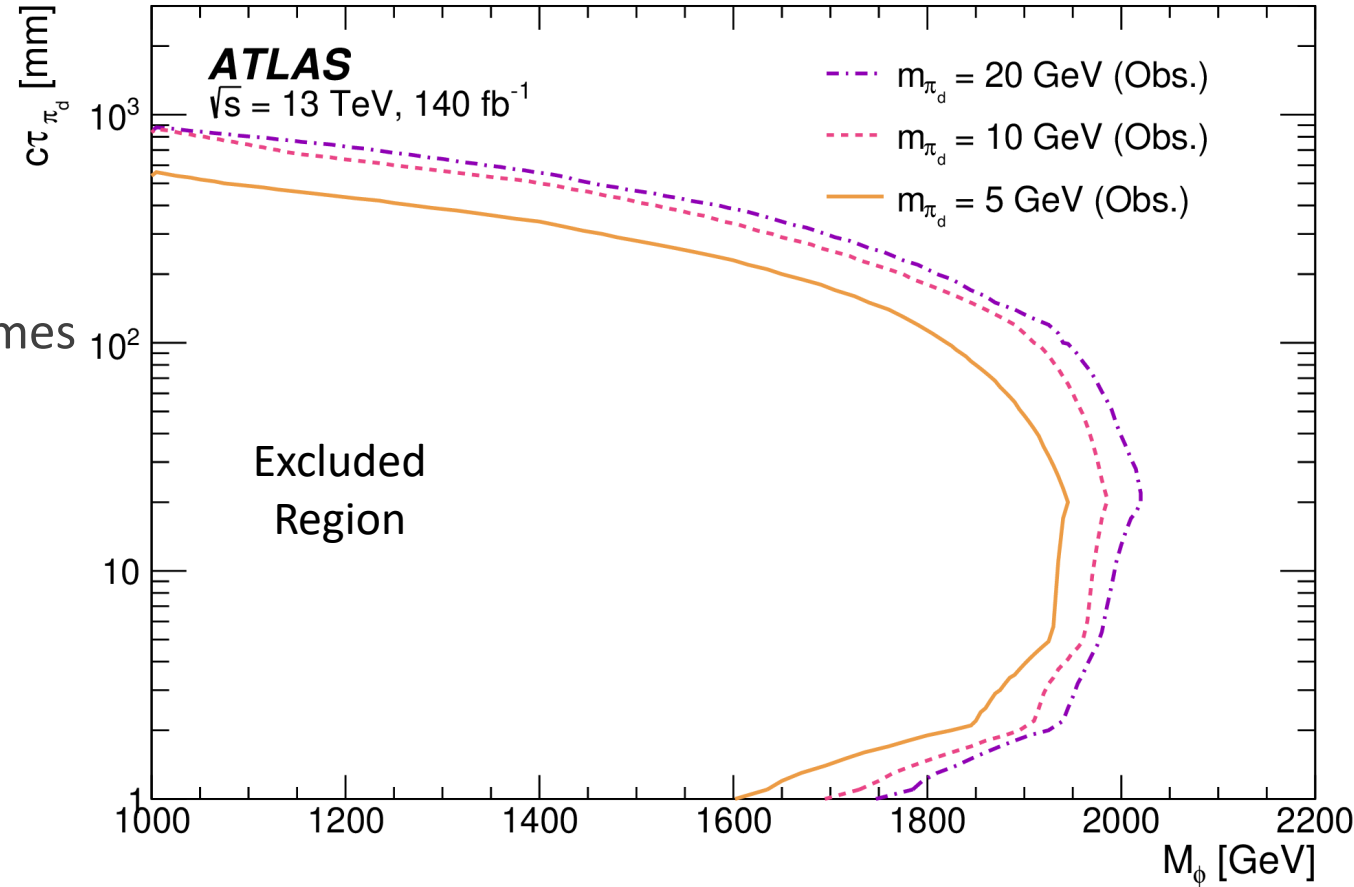

Conclusion

The (particle) nature of dark matter remains an exciting open question for now!

Strong new limits have been placed on the cross-sections for emerging jet models

- Many regions of the parameter space have now been excluded

Use of a combined two-stage BDT classifier proved very effective at identifying MC signal

Thank you!

Additional Slides

Background Estimation Validation

Two methods were used to validate the ABCD method

The analysis was performed in an orthogonal low- H_T region

- Background rich with negligible signal contamination (<0.001% signal contamination)

A shifted ABCD plane was used to estimate the counts in the last bin of the original C and D regions

- Difference between estimate and observed counts taken as uncertainty on the method

Region	Low- H_T VR	Shifted-ABCD VR
Predicted Counts	25 ± 3	215 ± 8
Observed Counts	24	209

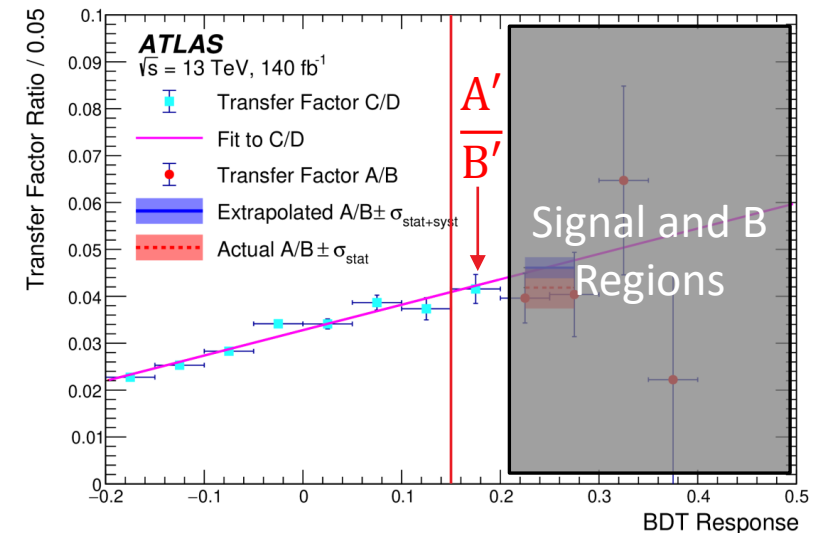
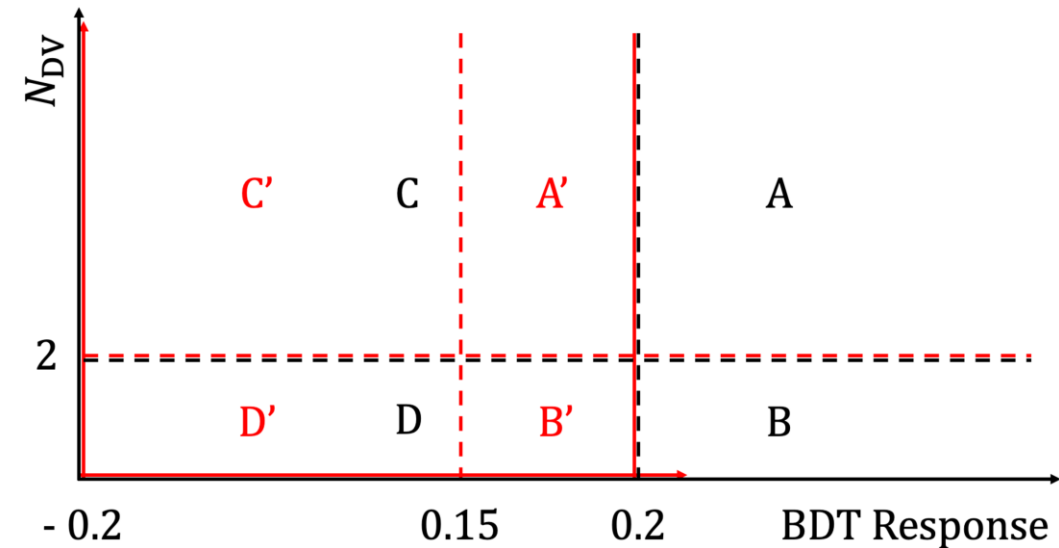

Additional Cross-Section Limits

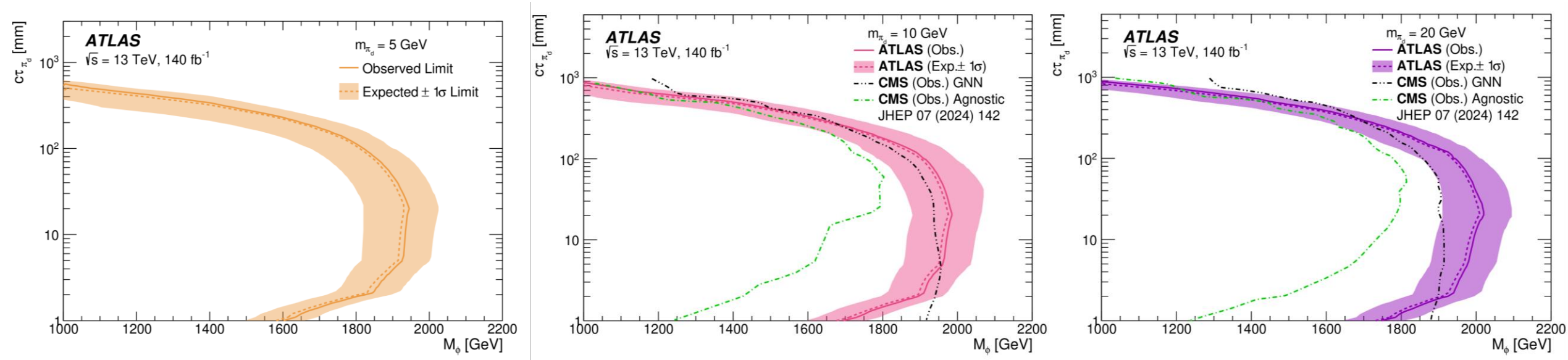

Observed and expected limits shown with uncertainties

Comparison with CMS Run 2 limits shown for $m_{\pi_d} = 10, 20$ GeV

- CMS search did not include $m_{\pi_d} = 5$ GeV

ATLAS analysis achieved stronger limits for intermediate π_d lifetimes