



**TRIUMF**

# **WATER CHERENKOV TEST EXPERIMENT (WCTE): LESSONS TOWARDS HYPER-K**

XIAOYUE LI  
CAP CONGRESS, OTTAWA  
JUNE 25, 2026

# HYPER-KAMIOKANDE

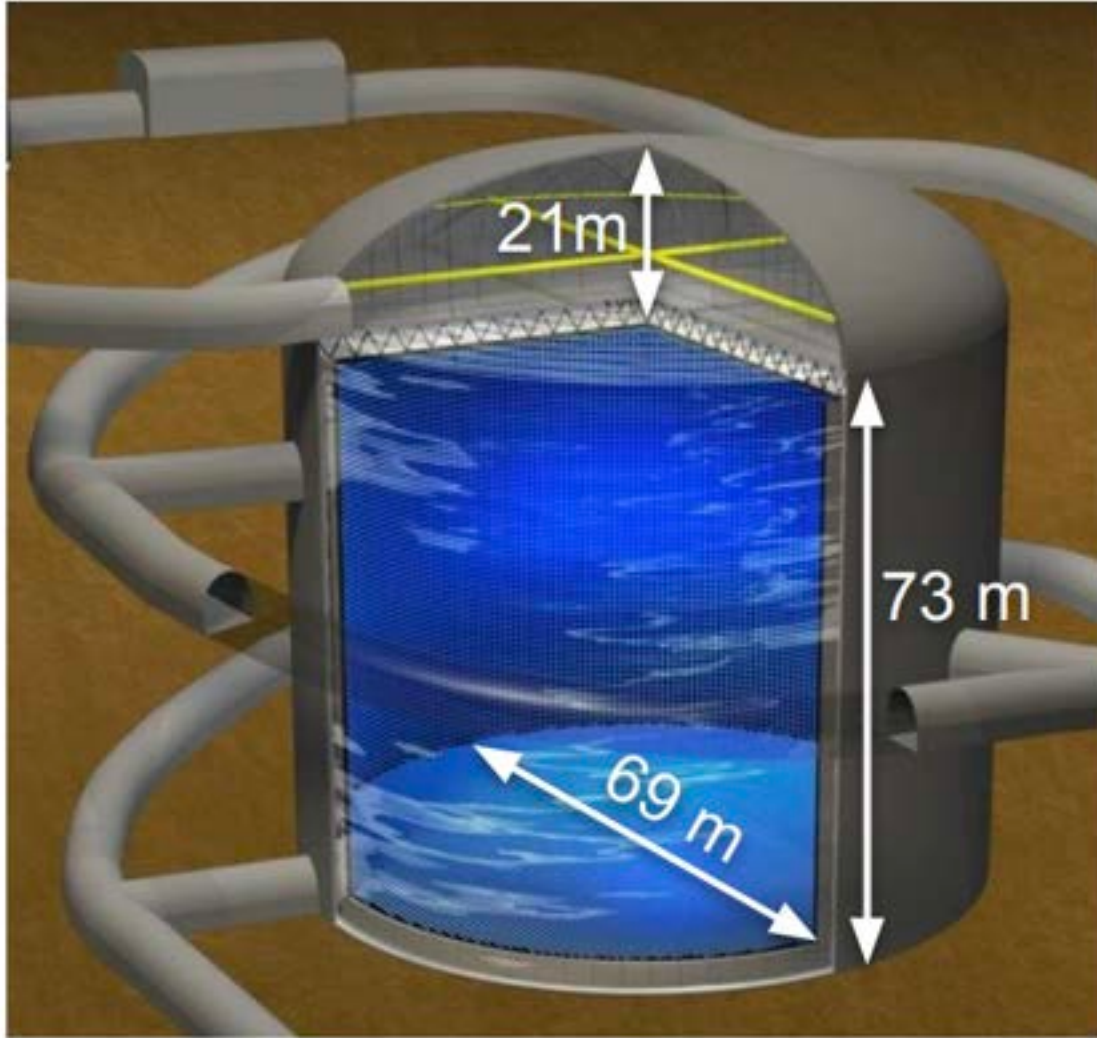

Intermediate Water Cherenkov Detector (IWCD)  
870 m from target  
(1.5°-4° off-axis)

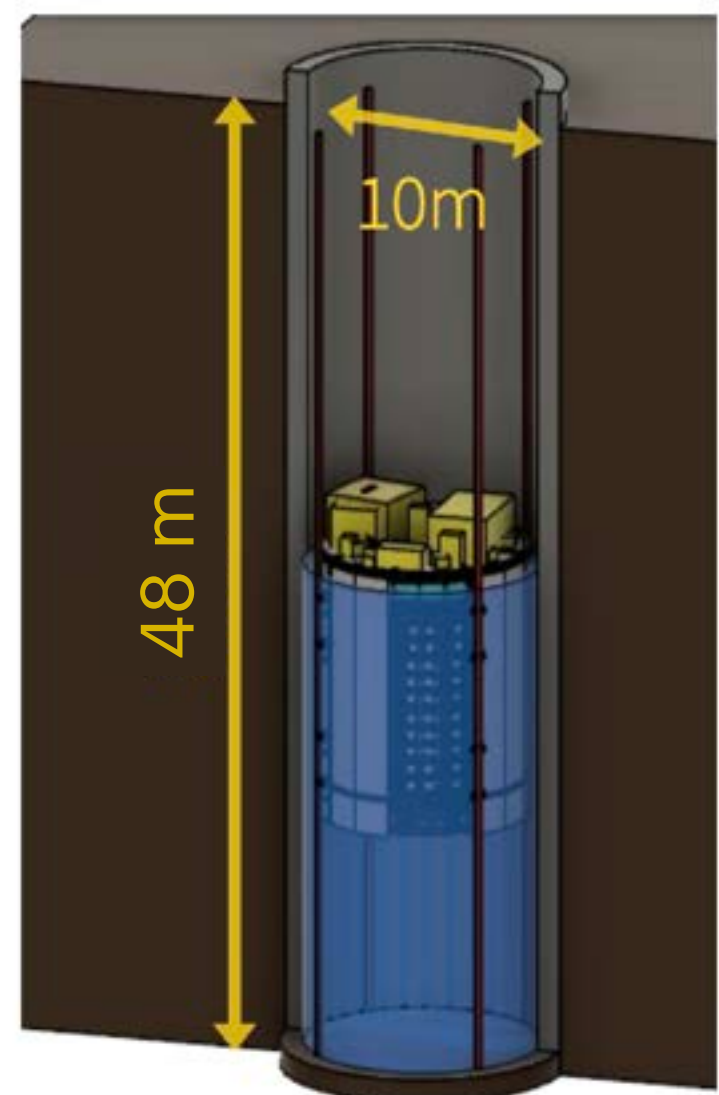

ND280 (2.5° off-axis)

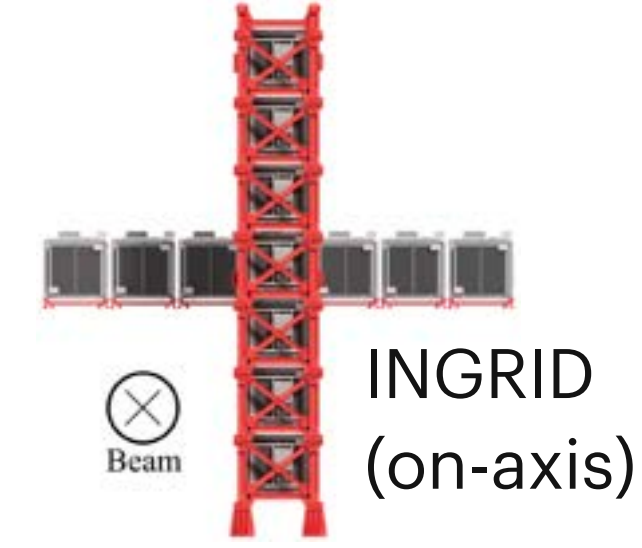
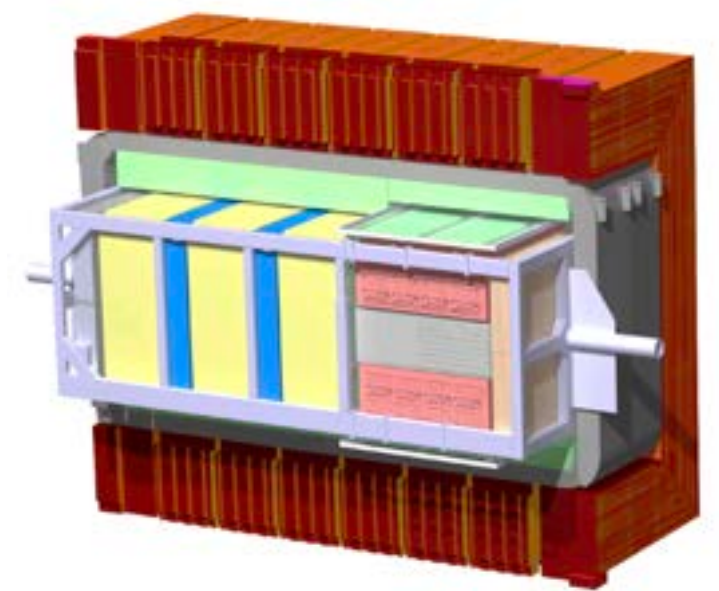

1.3 MW proton beam

Hyper-Kamiokande

Near Detectors

J-PARC

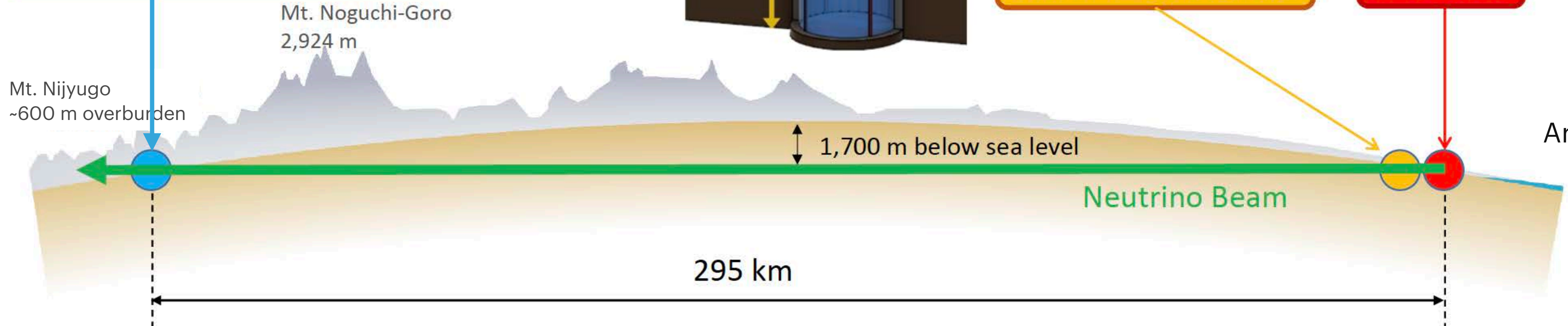

Arturo Fiorentini's talk, T1-8

# HYPER-KAMIOKANDE

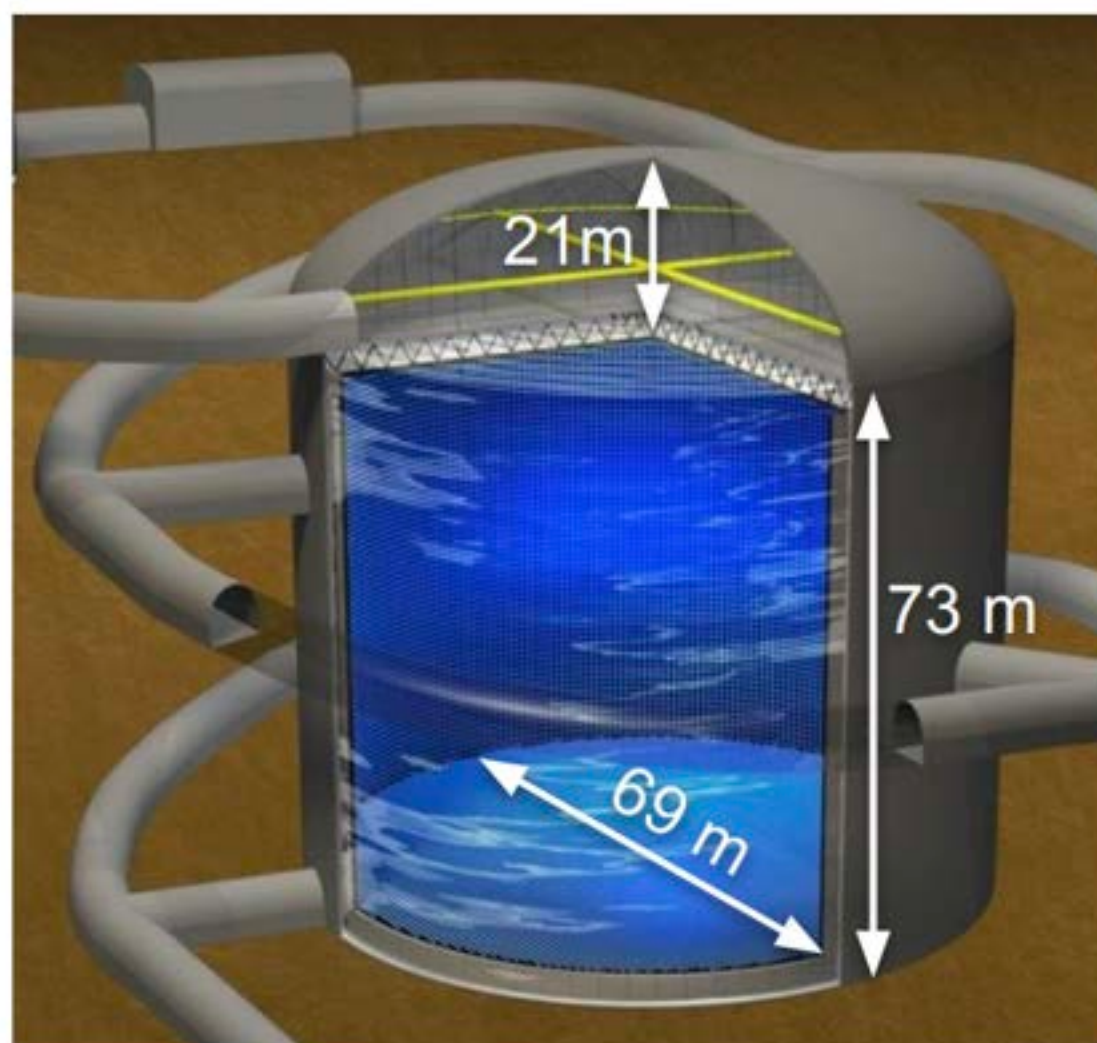

- ▶ Over a thousand  $\nu_e$  and  $\bar{\nu}_e$  events after 10 years of operation
- ▶ Systematic uncertainties will soon surpass statistical uncertainty

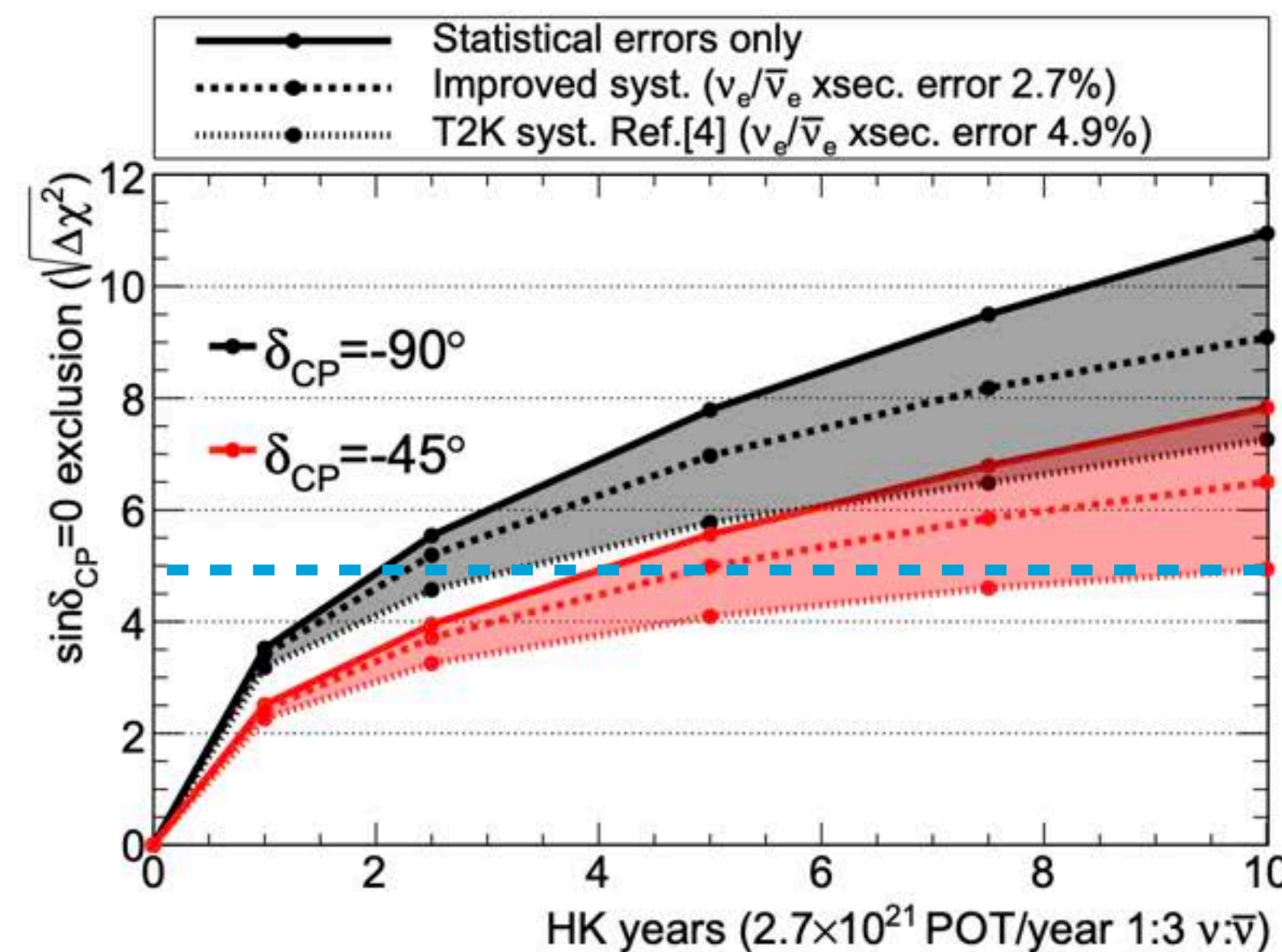
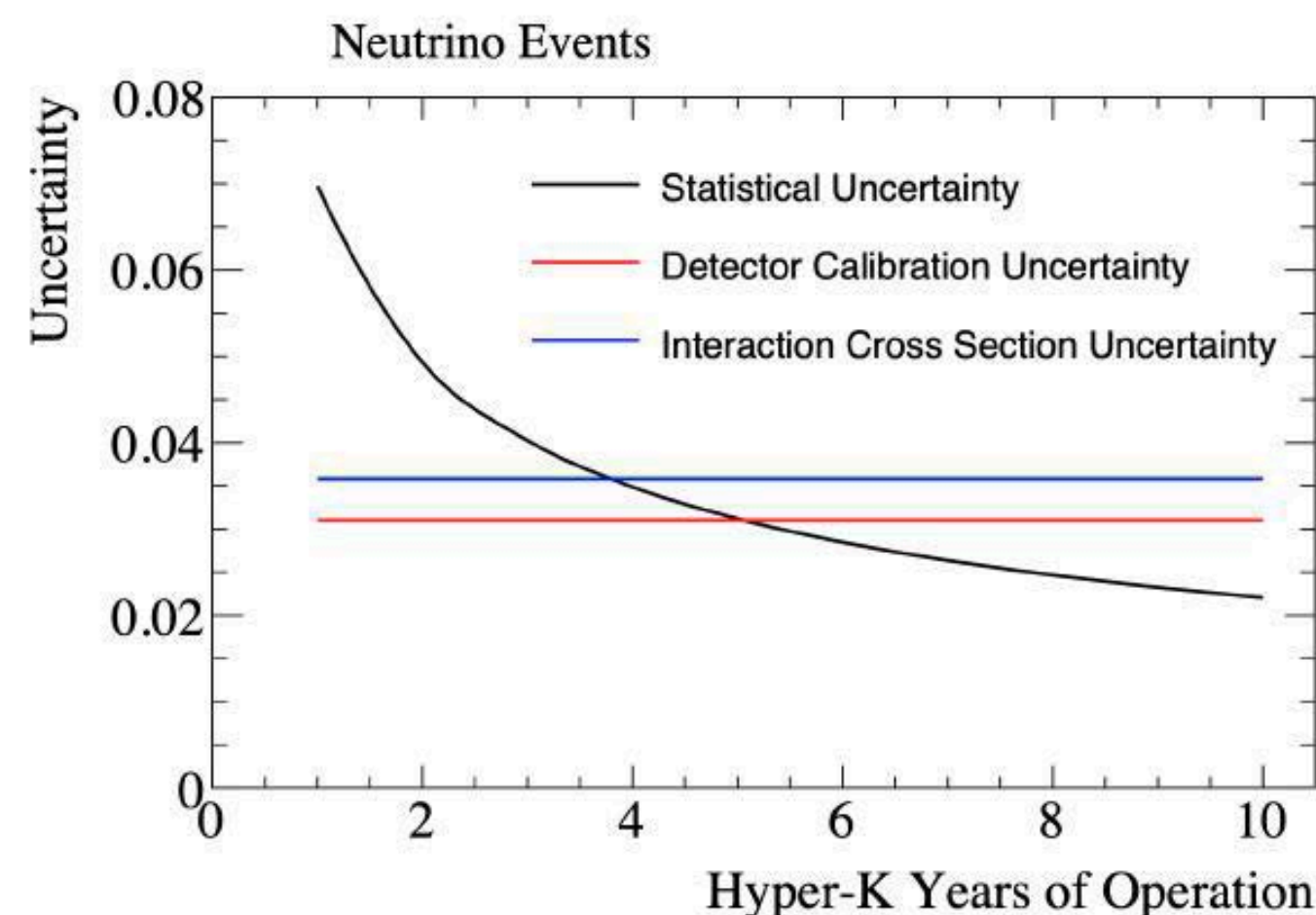
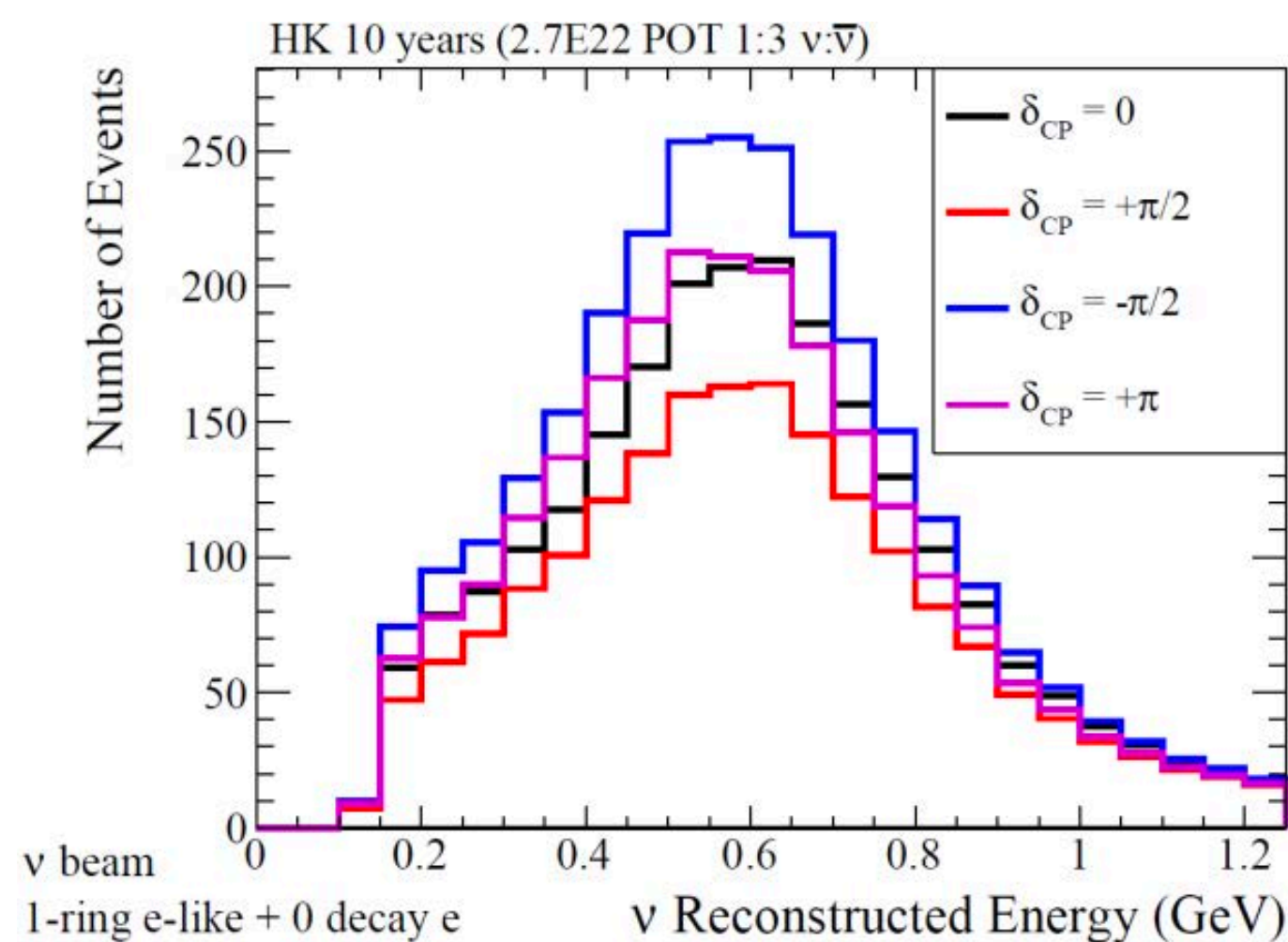

- ▶ Systematic uncertainties limit  $\delta_{CP}$  sensitivity
- ▶  $\nu_e/\bar{\nu}_e$  cross section ratio
- ▶ Detector systematic uncertainties

# INTERMEDIATE WATER CHERENKOV DETECTOR (IWCD)

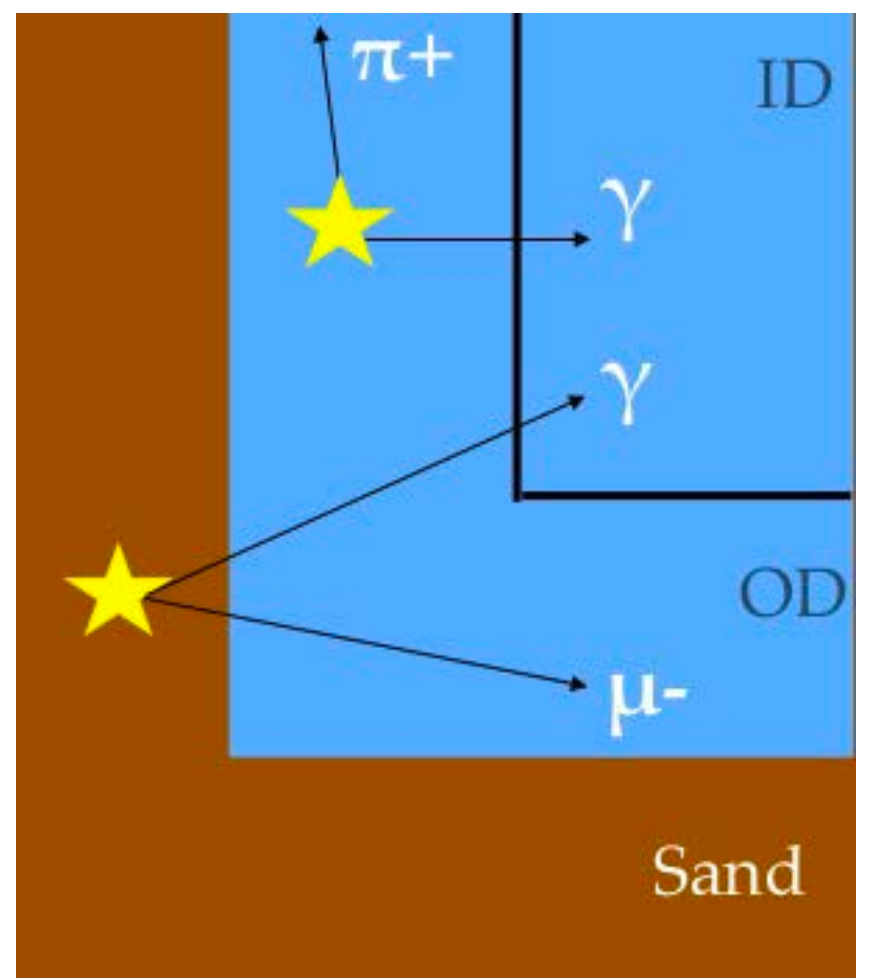
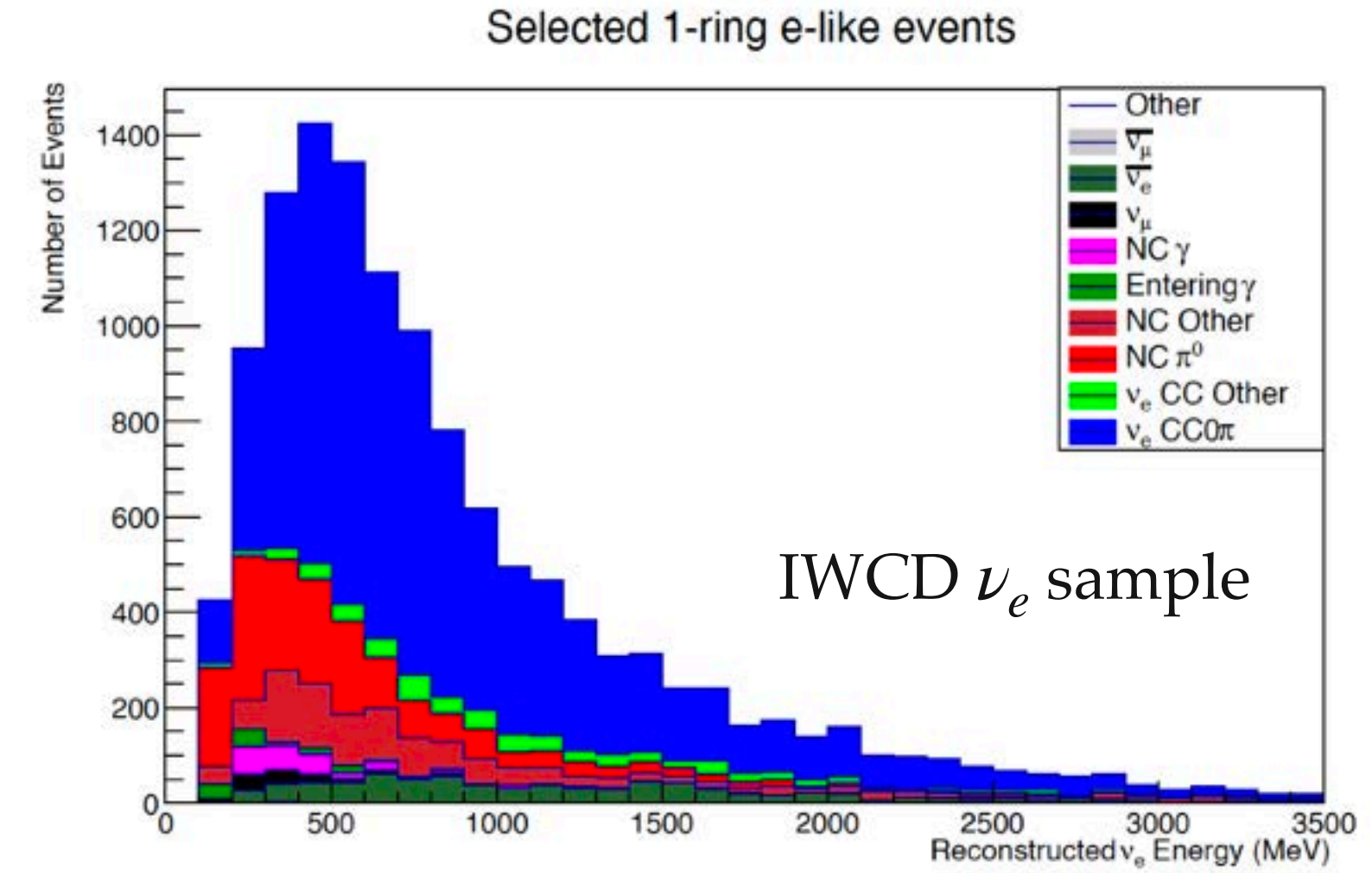
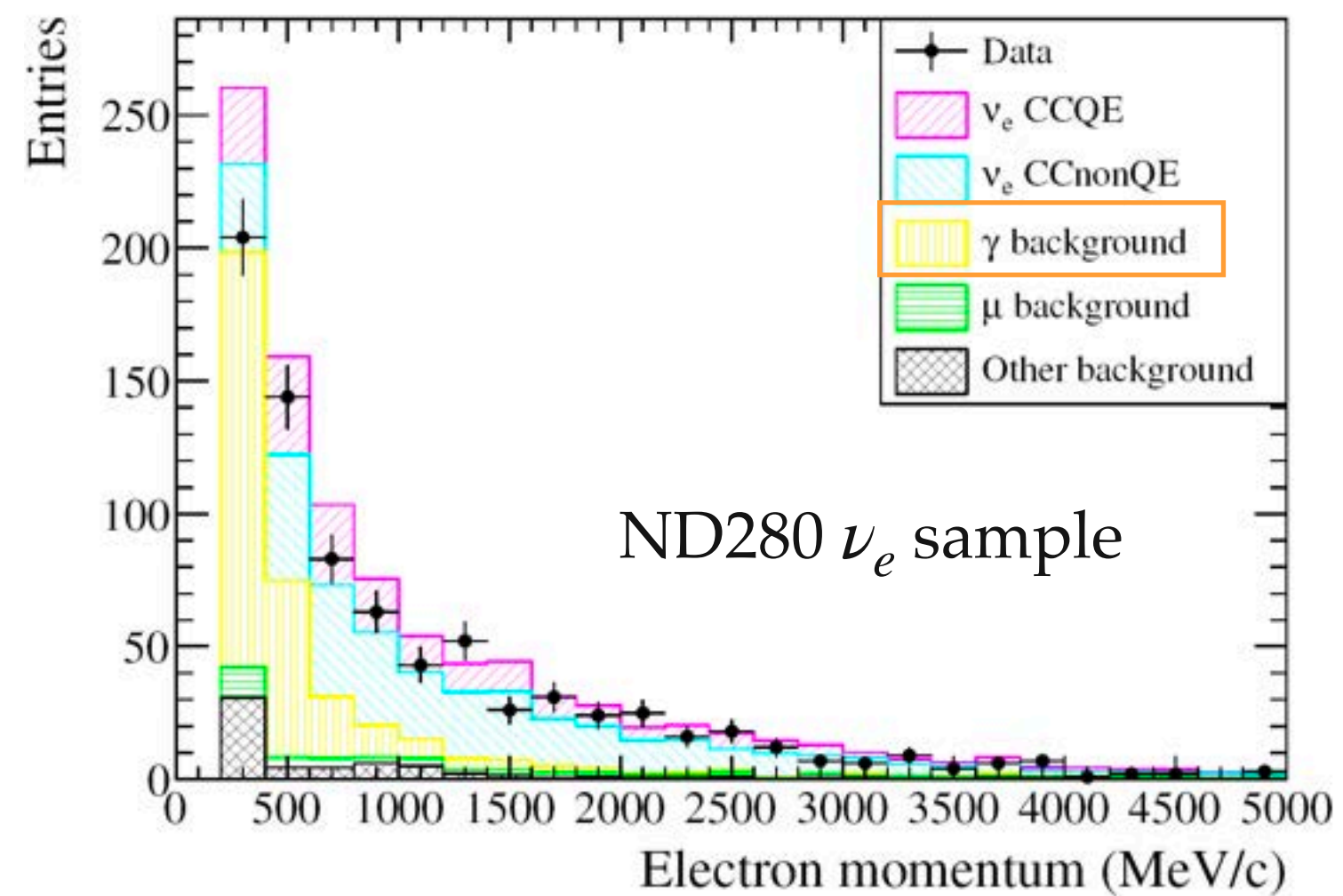
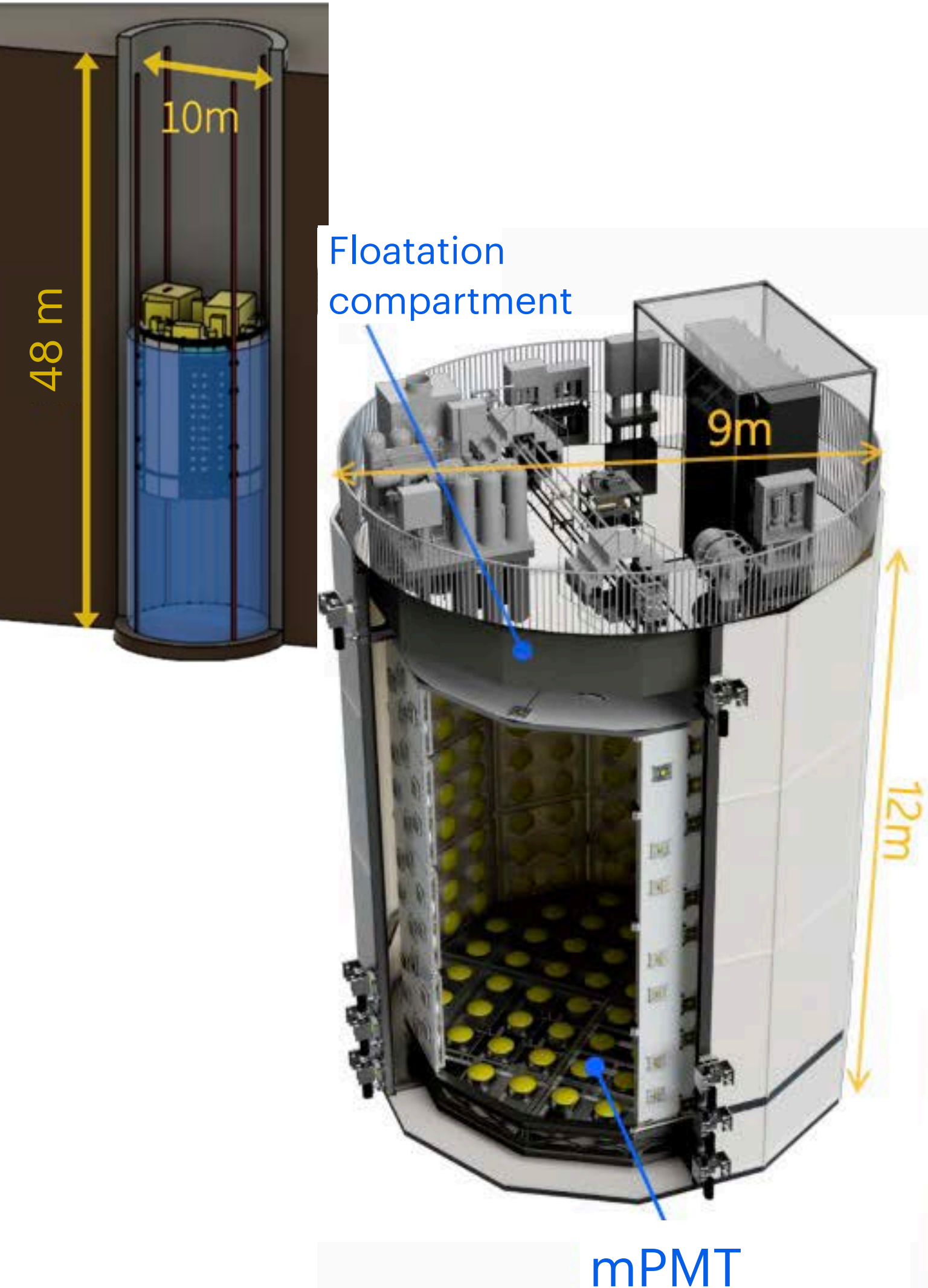

- ▶ IWCD can measure the 1% intrinsic beam  $\nu_e / \bar{\nu}_e$
- ▶ Self-shield against entering gammas, a dominant background for ND280  $\nu_e / \bar{\nu}_e$  measurement
- ▶ IWCD can improve the constraint on  $(\sigma_{\nu_\mu} / \sigma_{\nu_e}) / (\sigma_{\bar{\nu}_\mu} / \sigma_{\bar{\nu}_e})$ , which is currently estimated by theory at ~5%

# INTERMEDIATE WATER CHERENKOV DETECTOR (IWCD)

$$R(\vec{x}) = \underbrace{\Phi(E_\nu)}_{\text{Neutrino flux}} \times \underbrace{\sigma(E_\nu, \vec{x})}_{\text{Neutrino Cross section}} \times \underbrace{\epsilon(\vec{x})}_{\text{Detector efficiency}} \times \underbrace{P(\nu_A \rightarrow \nu_B)}_{\text{Oscillation probability}}$$

Neutrino rate at far detector

Reconstructed energy spectrum of  $\nu_\mu$  at FD

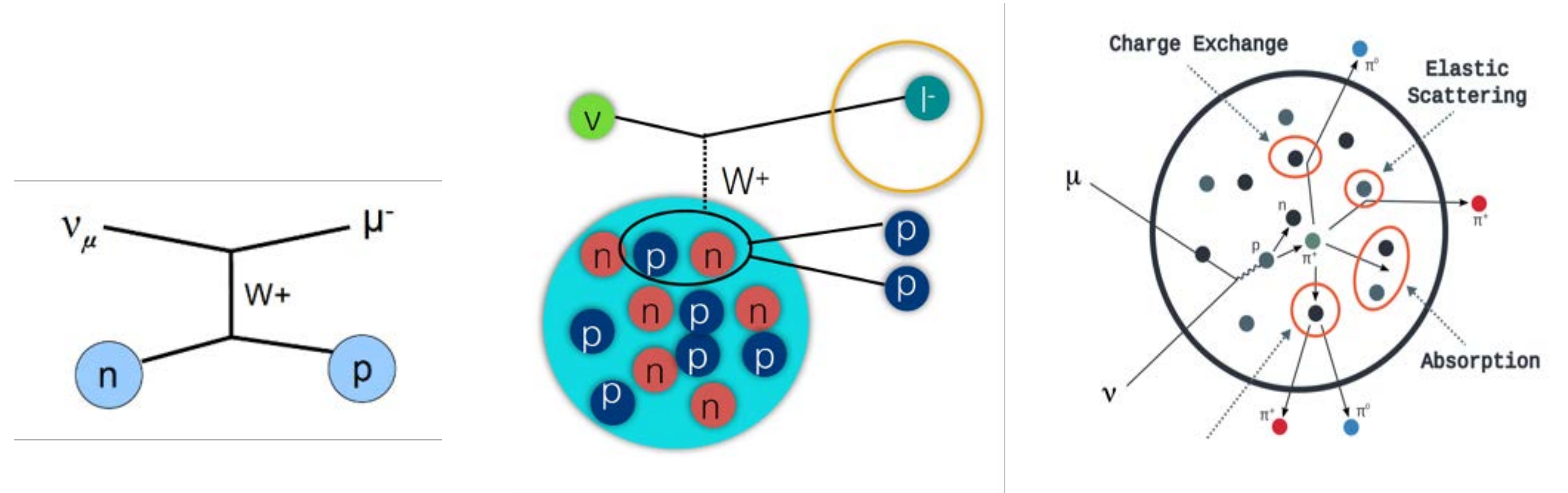
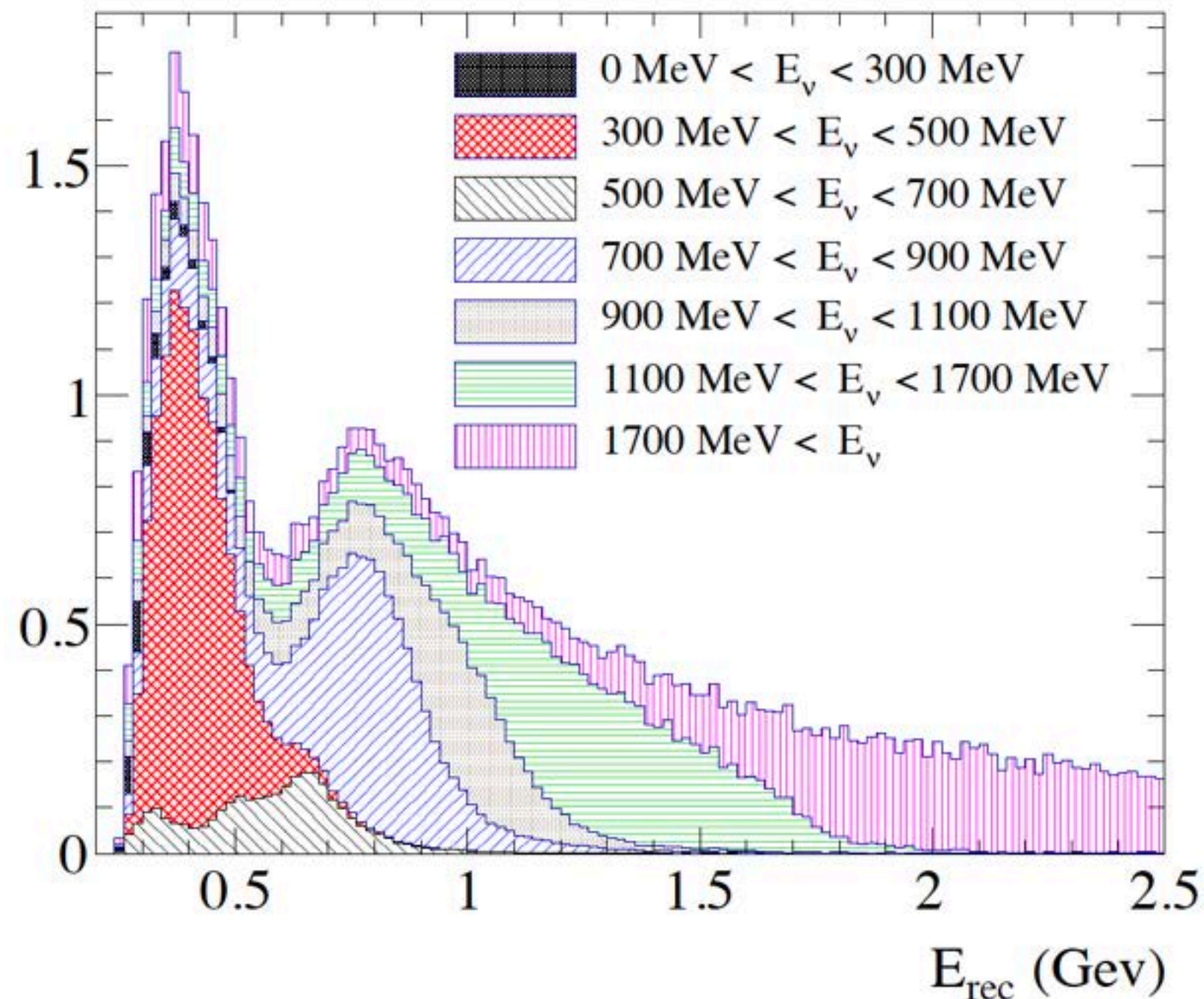

- ▶ The way in which neutrino energy is reconstructed leads to “feed-down” effect
  - ▶ Known incoming neutrino direction + lepton kinematics = neutrino energy (assuming two-body interaction with a single nucleon)
  - ▶ Multi-nucleon interaction, pion production, nuclear effect, etc. tend to lower reconstructed neutrino energy

# INTERMEDIATE WATER CHERENKOV DETECTOR (IWCD)

$$R(\vec{x}) = \underbrace{\Phi(E_\nu)}_{\text{Neutrino flux}} \times \underbrace{\sigma(E_\nu, \vec{x})}_{\text{Neutrino Cross section}} \times \underbrace{\epsilon(\vec{x})}_{\text{Detector efficiency}} \times \underbrace{P(\nu_A \rightarrow \nu_B)}_{\text{Oscillation probability}}$$

Neutrino rate at far detector

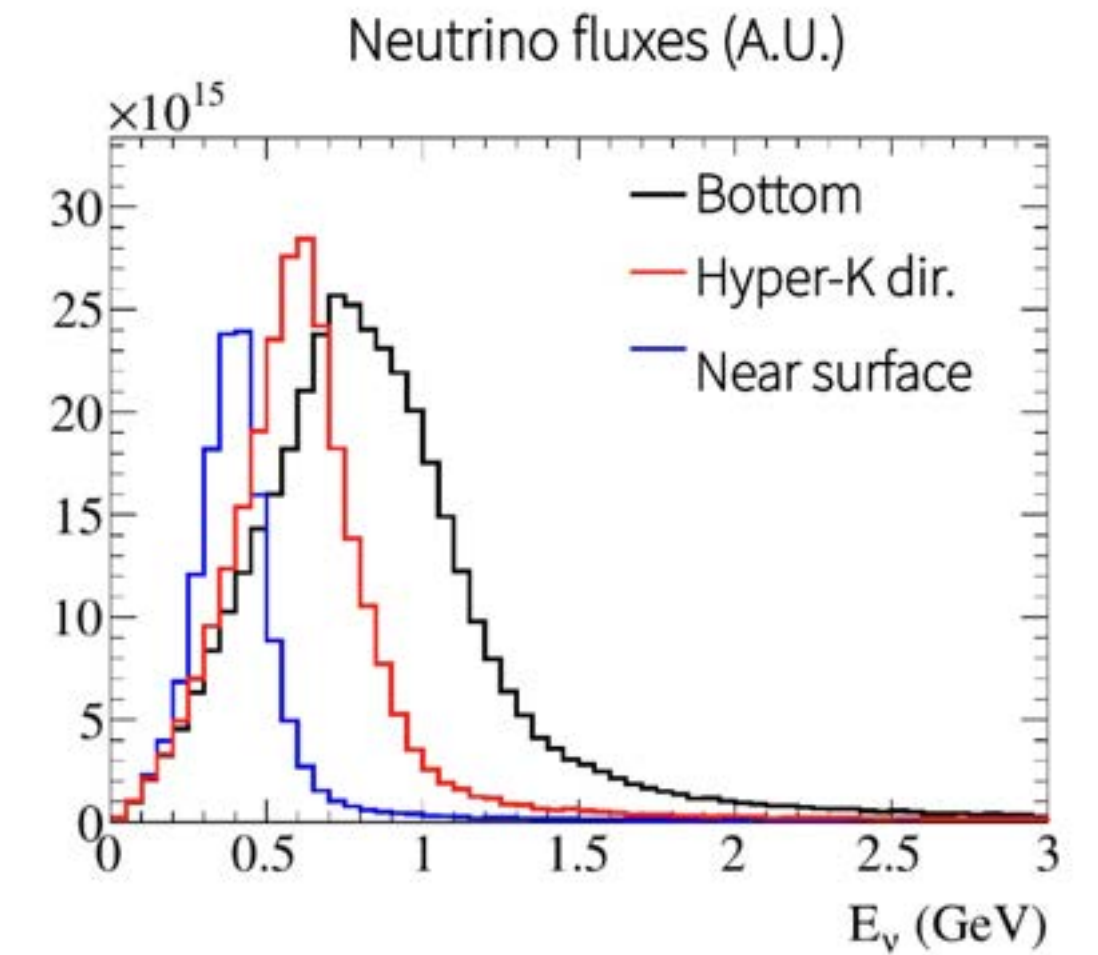
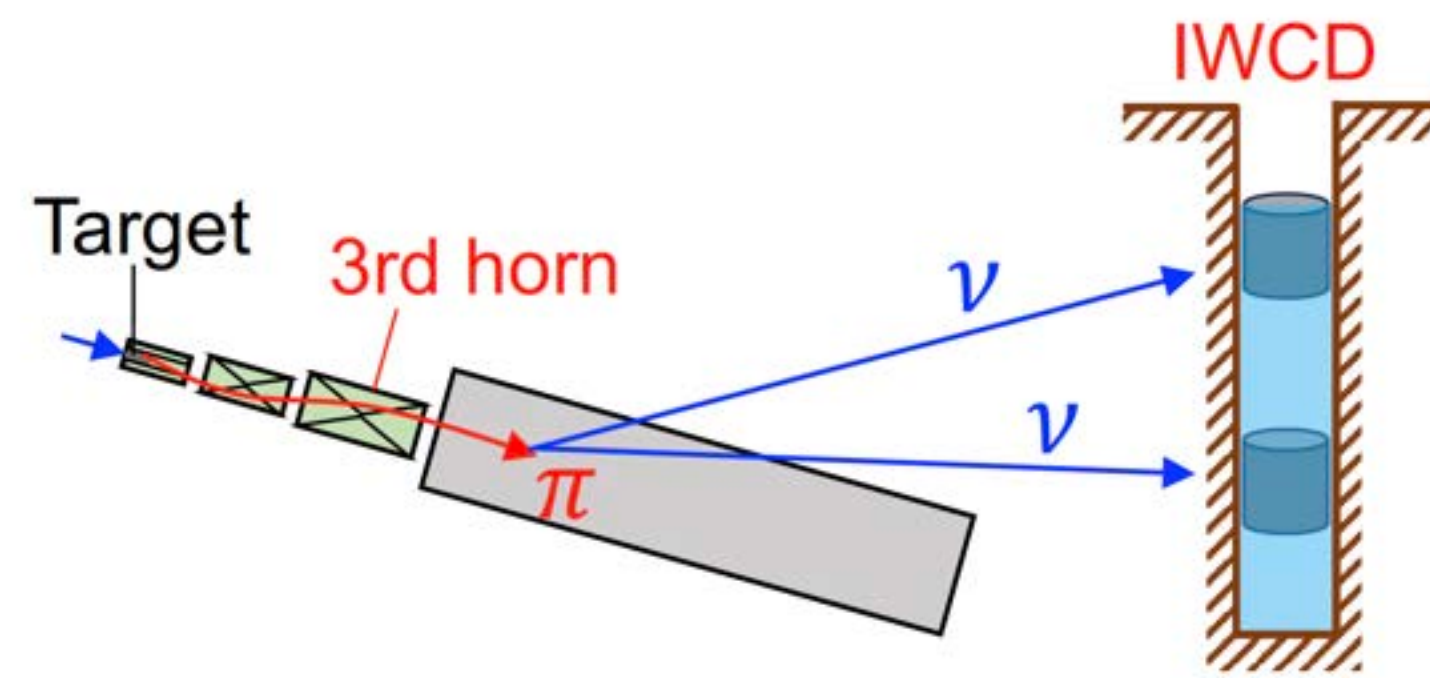

Reconstructed energy spectrum of  $\nu_\mu$  at FD

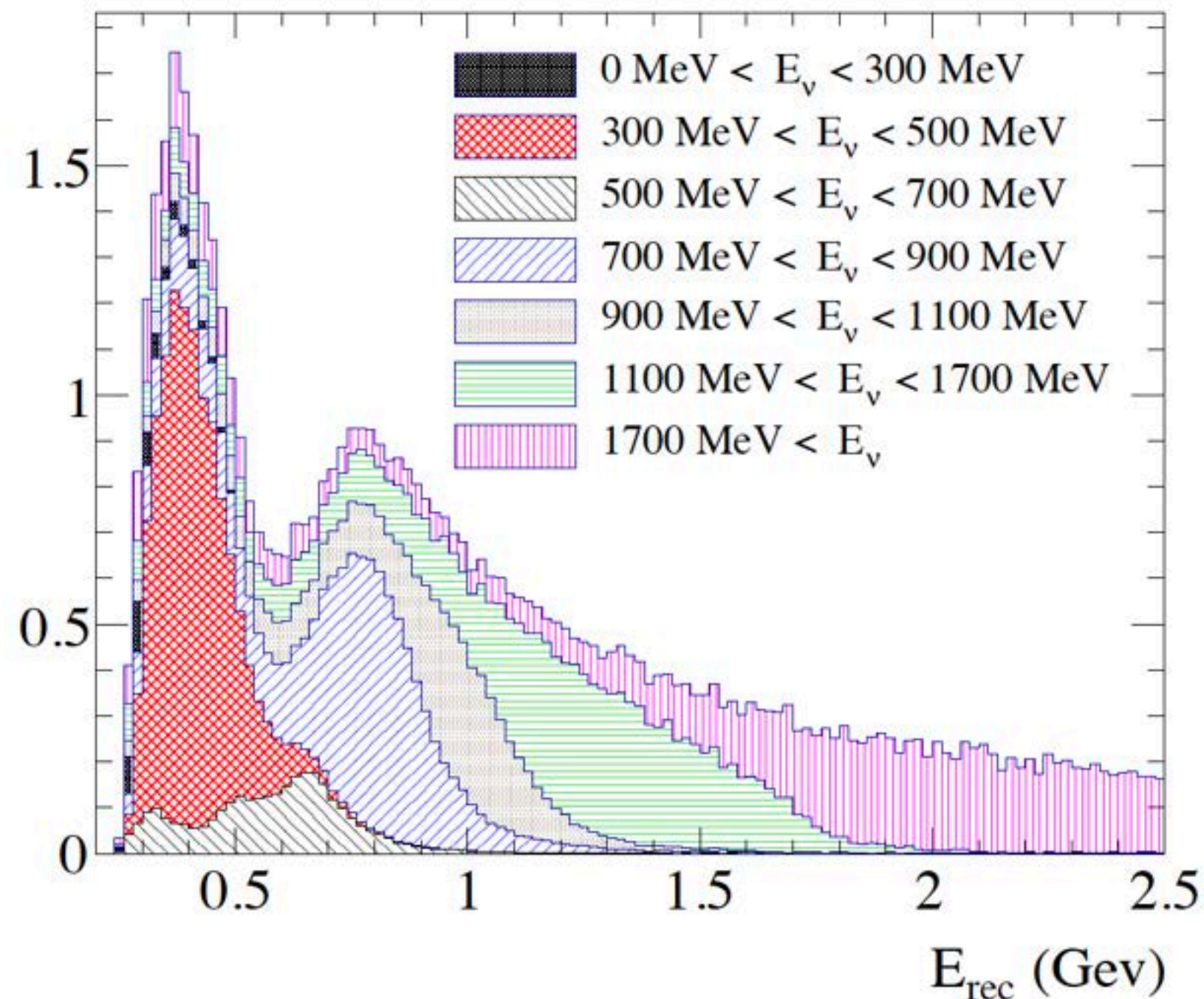

- ▶ The way in which neutrino energy is reconstructed in leads to “feed-down” effect
- ▶ IWCD can probe this effect with measurements at different off-axis angles and make flux ⊗ xsec measurement more robust
- ▶ **This means understanding the detector is ever more crucial**
- ▶ **Best if can be tested with control samples**

# WATER CHERENKOV TEST EXPERIMENT (WCTE)

- ▶ Water Cherenkov Test Experiment (WCTE) acts as prototype for IWCD
  - ▶ 93 IWCD mPMTs and 4 Hyper-K mPMTs installed
  - ▶ Testbed for water Cherenkov detector systems and new calibration techniques
  - ▶ Detector height/diameter is  $\sim 1/2$  of IWCD
- ▶ Operated in CERN T9 (East Hall) beam line from Oct. 2024 to Jun. 2025
  - ▶ Pure water and Gd-doped operations
- ▶ Data collected for  $\pi^\pm, p, e^\pm, \mu^\pm, \gamma$  at 0.08 ~ 1.8 GeV/c
- ▶ Also opportunity for important reconstruction and physics studies that will benefit IWCD and Hyper-K and help reduce systematic uncertainties

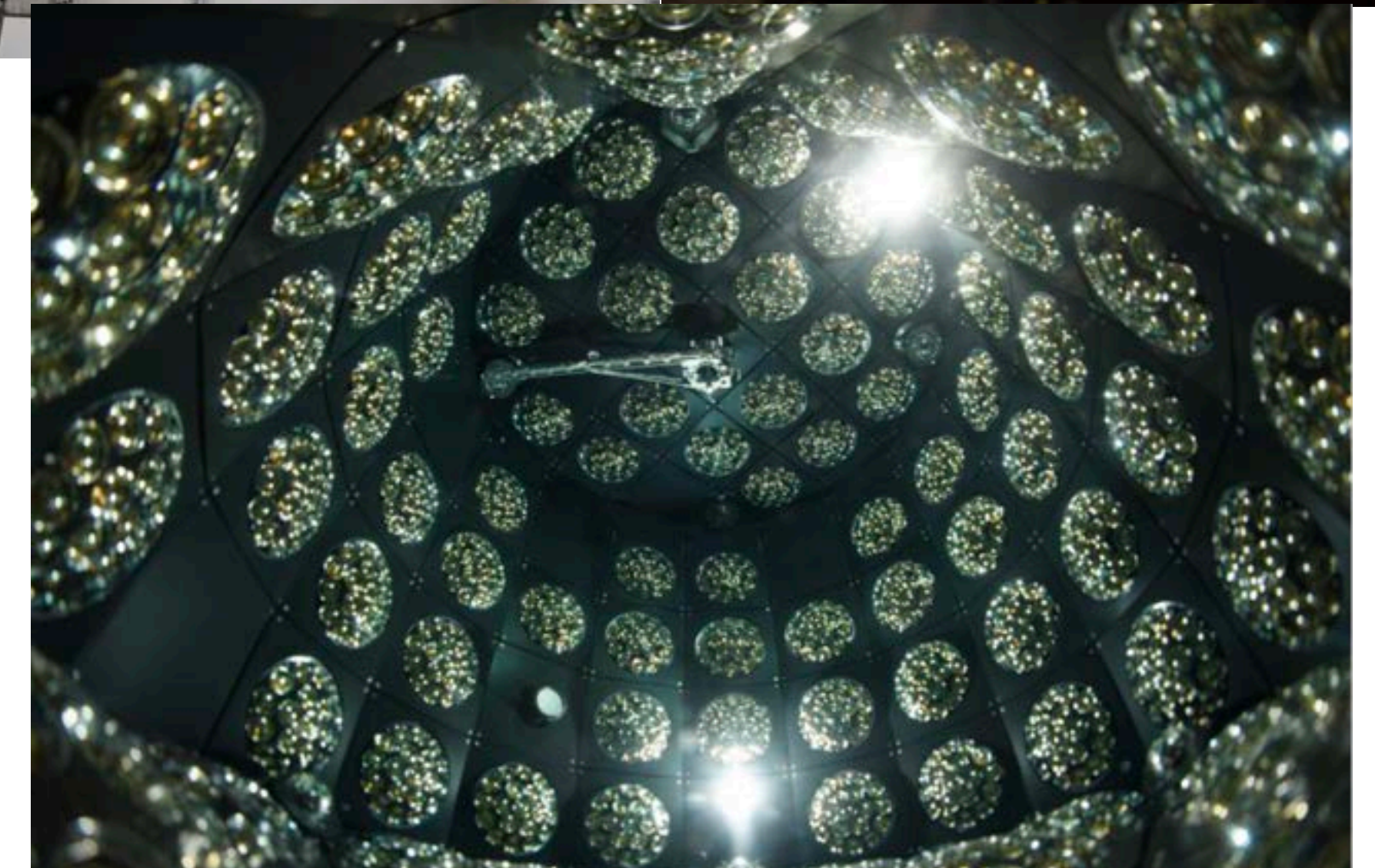
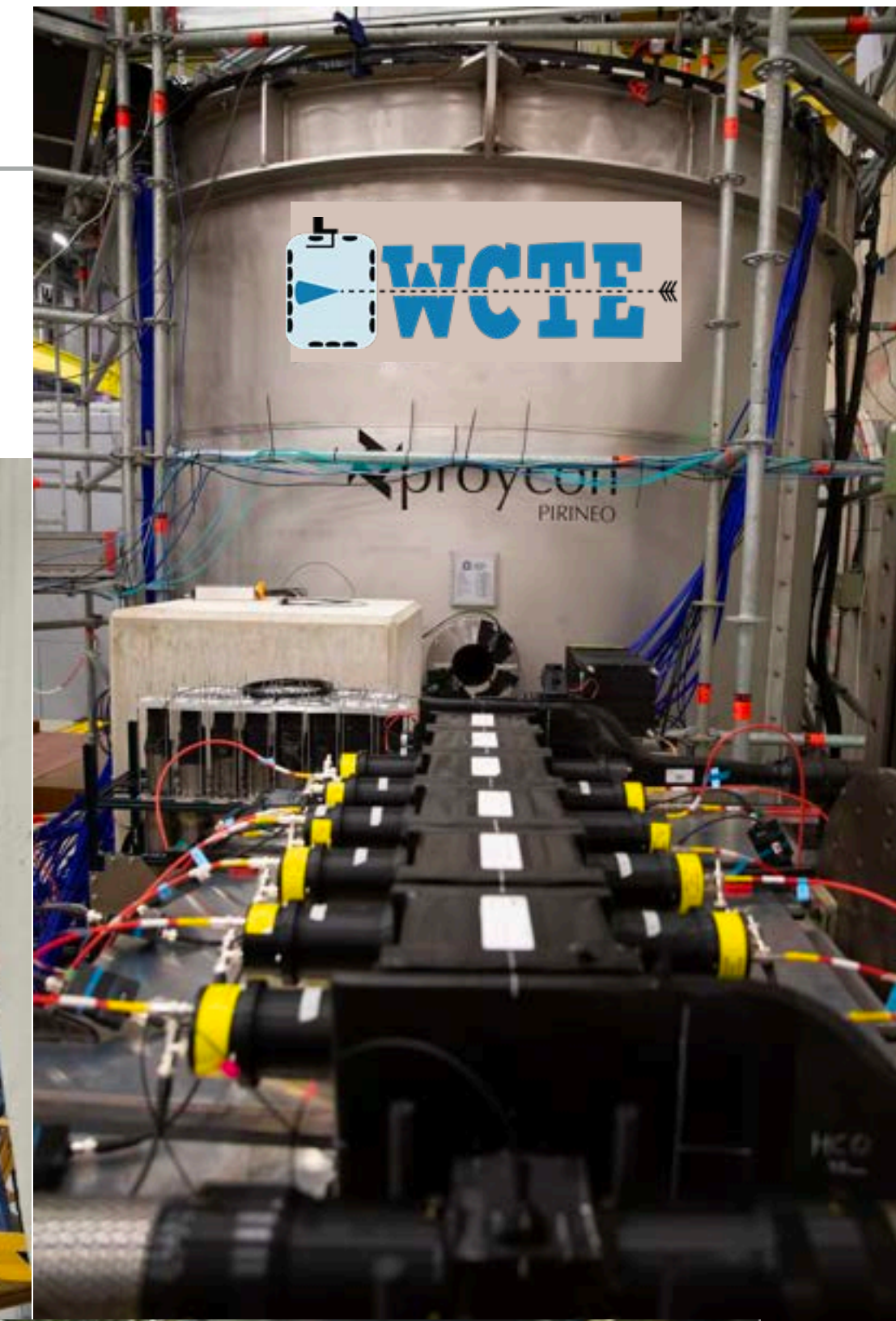

# WCTE TIMELINE

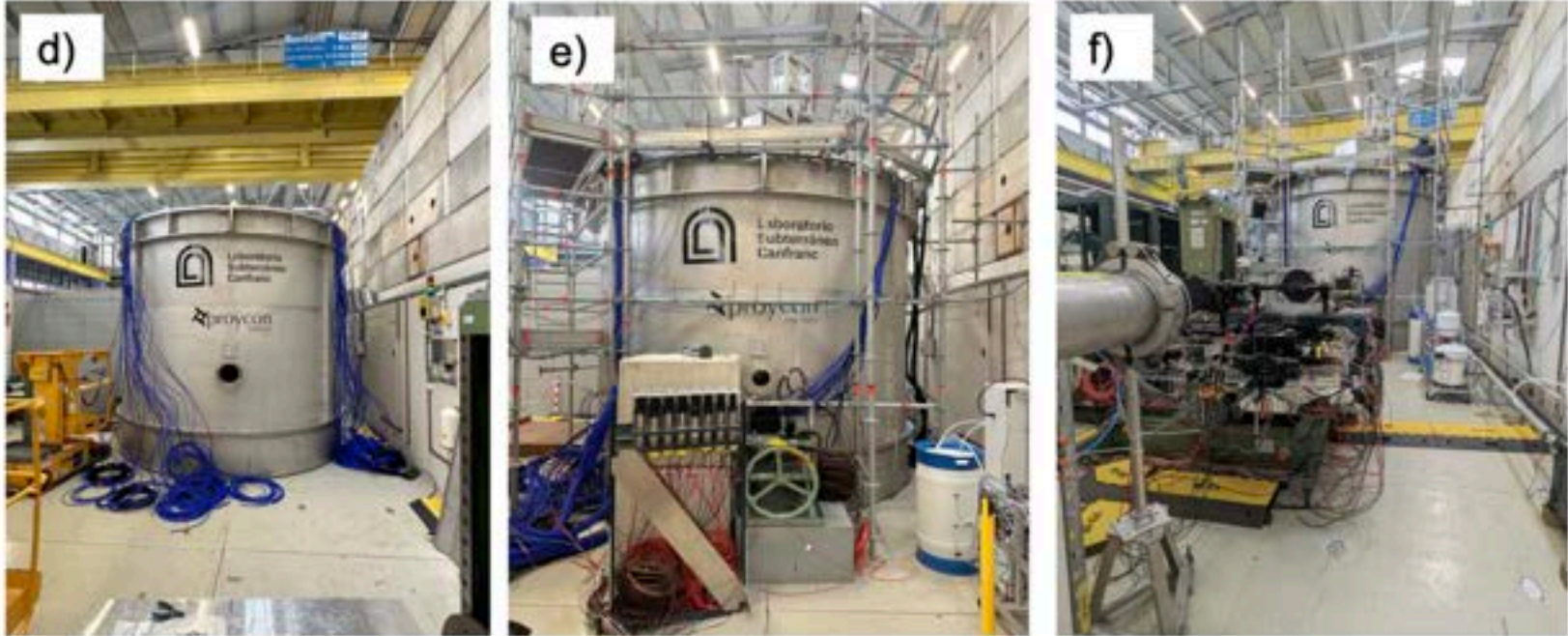
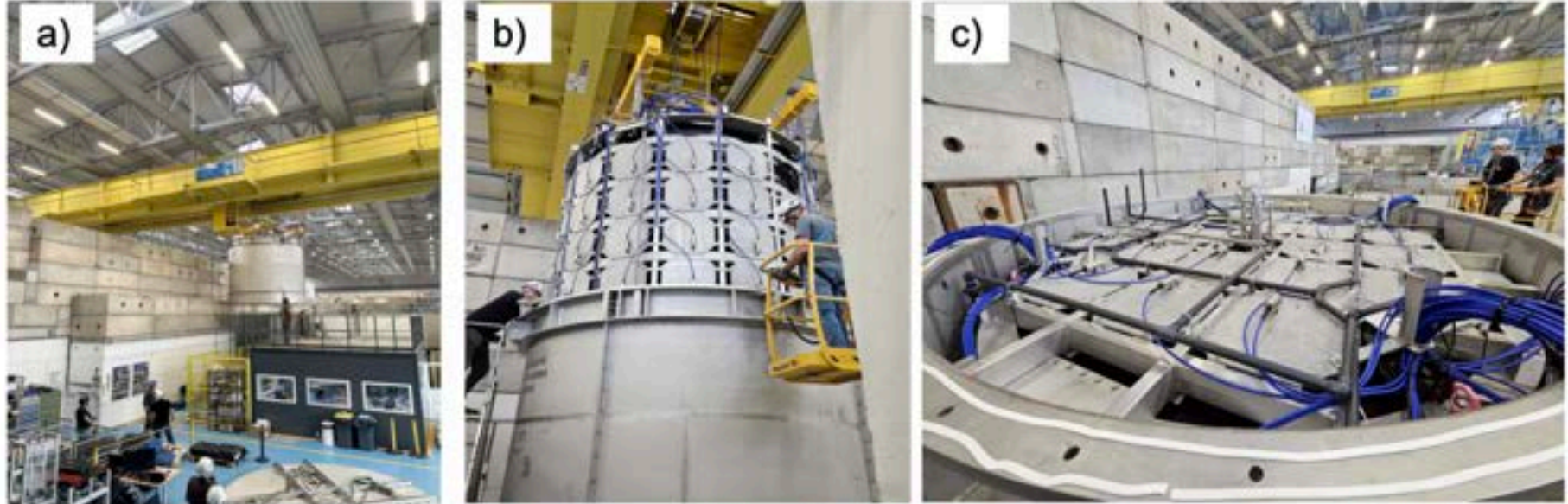
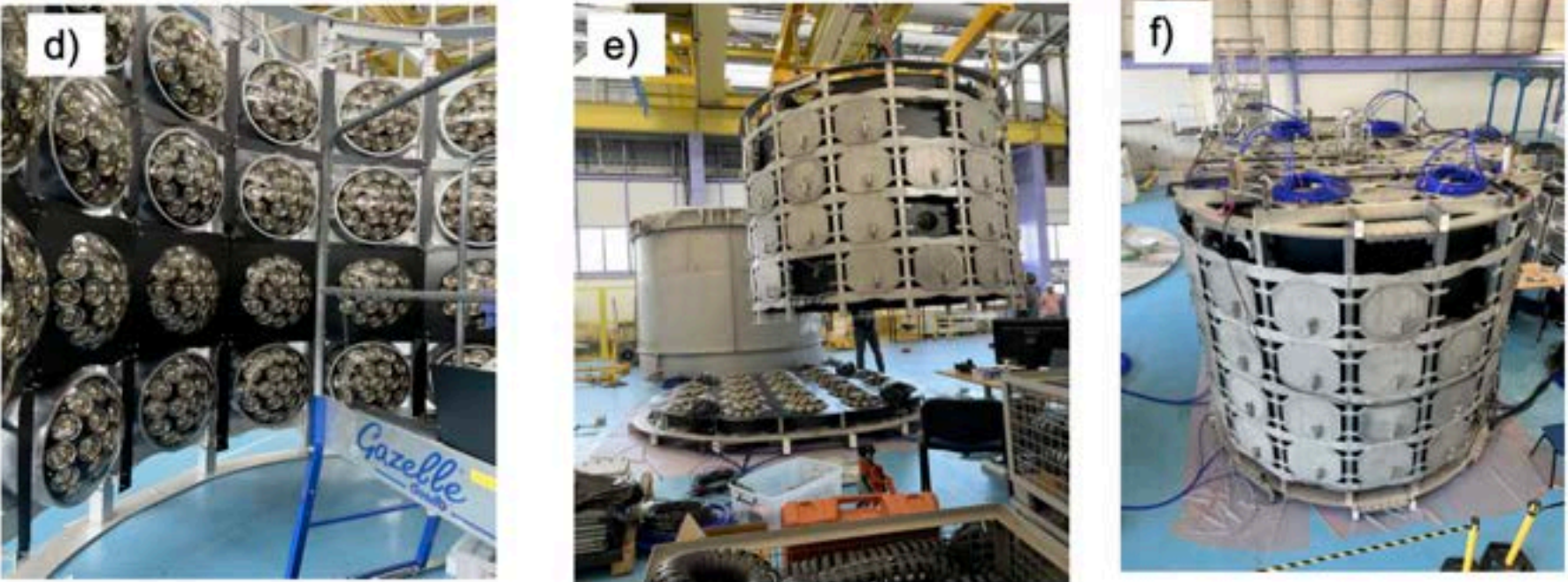
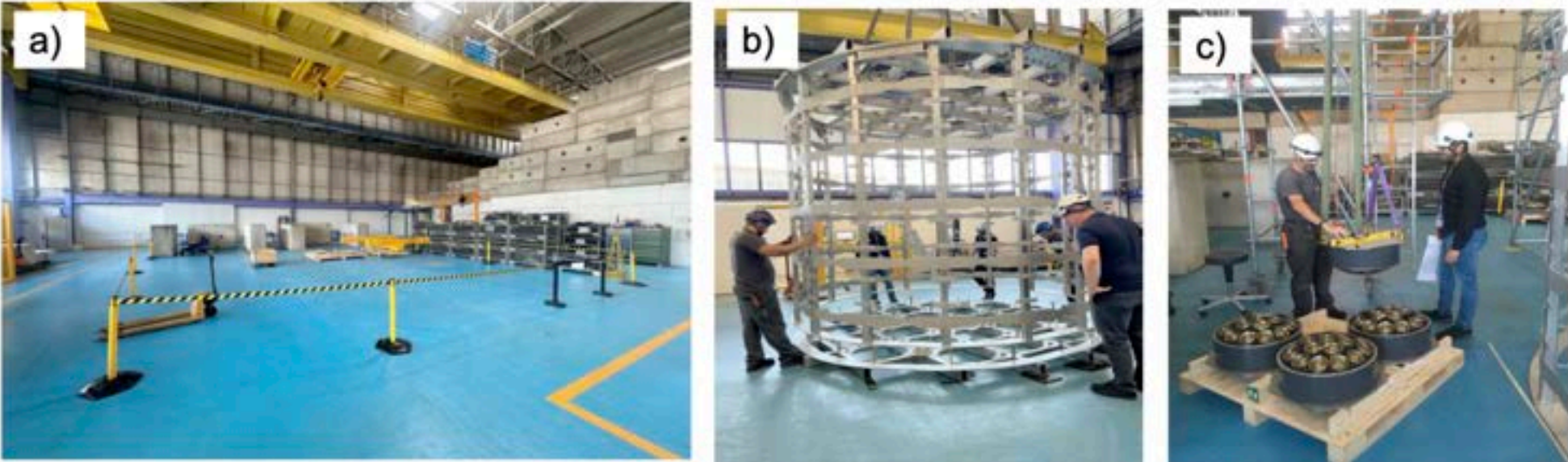
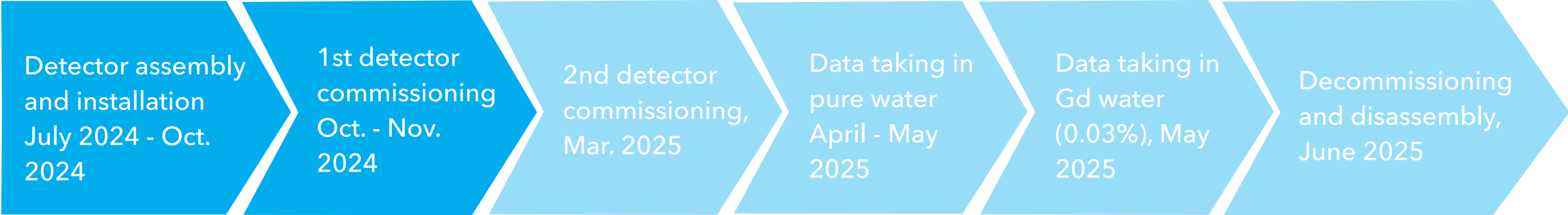

# WCTE TIMELINE

20 "bad" mPMTs (ADC corruption problem) in 2024 run are recovered by firmware update → 83 working IWCD mPMTs

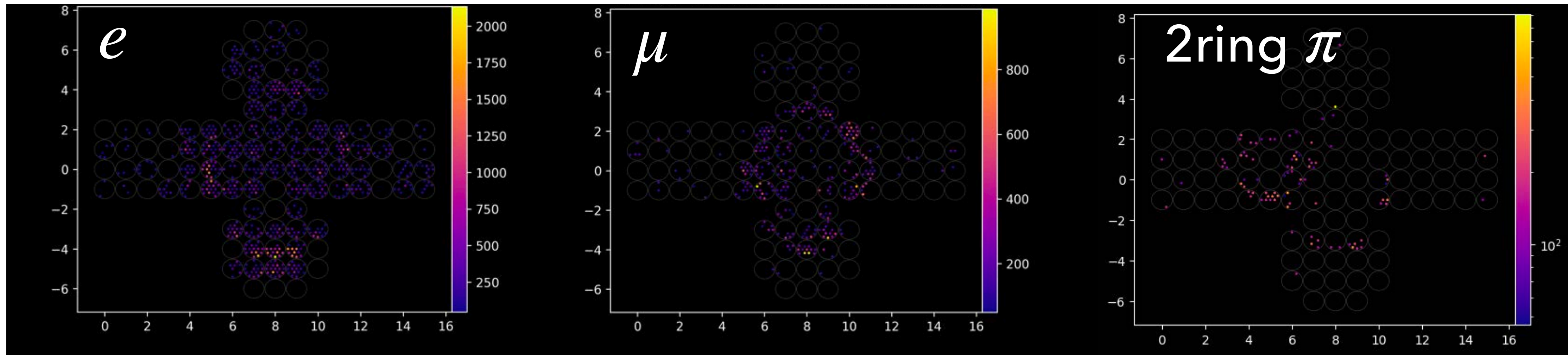
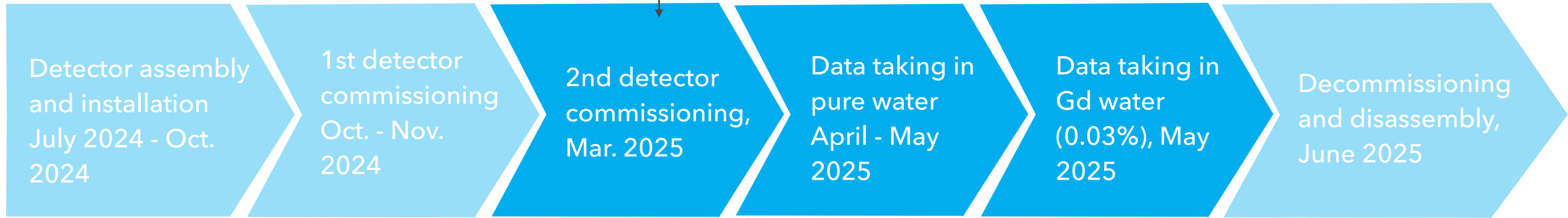

Ring structures clearly seen in the small water Cherenkov detector with small distance from detector wall!

# WCTE TIMELINE

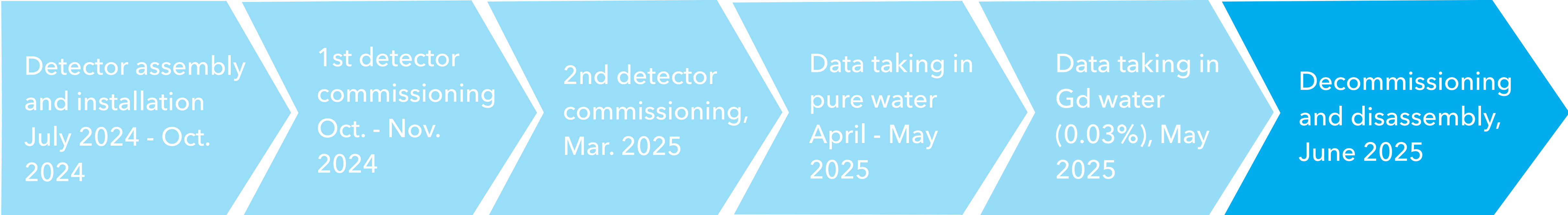

# WCTE BEAM MONITORS

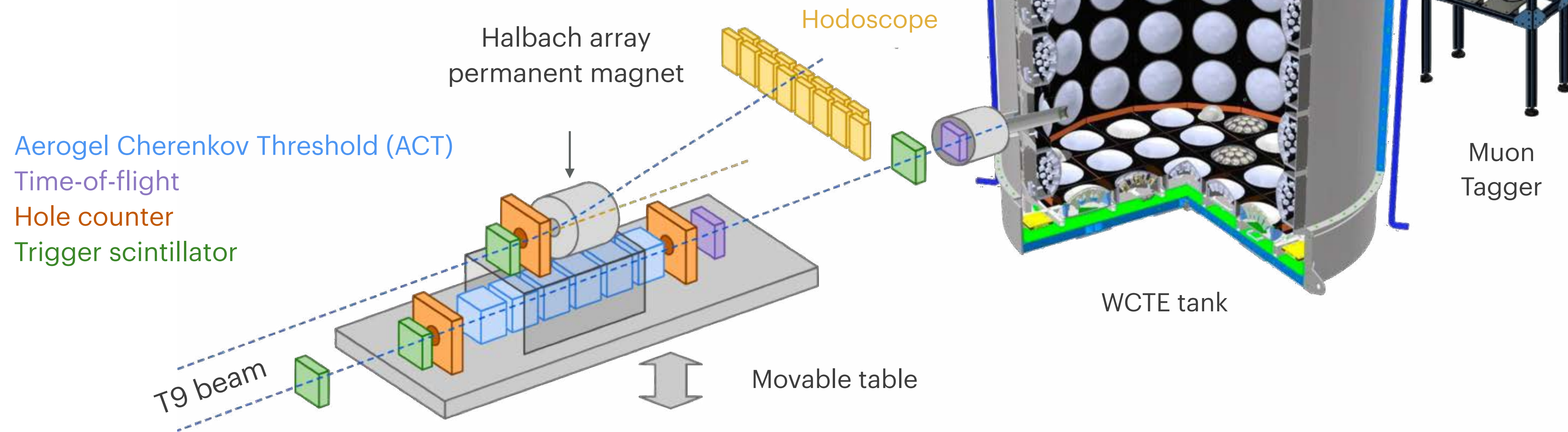

- ▶ Charge particles identified by beam monitors **event-by-event** based on time of flight and charge measured by Aerogel Cherenkov Threshold (ACT) detectors
  - ▶ Beam momentum calculated from time of flight
- ▶ Tagged gamma beam using permanent magnet and hodoscope for gamma energy determination
- ▶ Three beam papers in preparation

# BEAM DETECTORS - CHARGED PARTICLE

- Trigger scintillator
- Hole counter
- Aerogel Cherenkov Threshold detector
- Time-of-flight scintillator
- Muon tagger

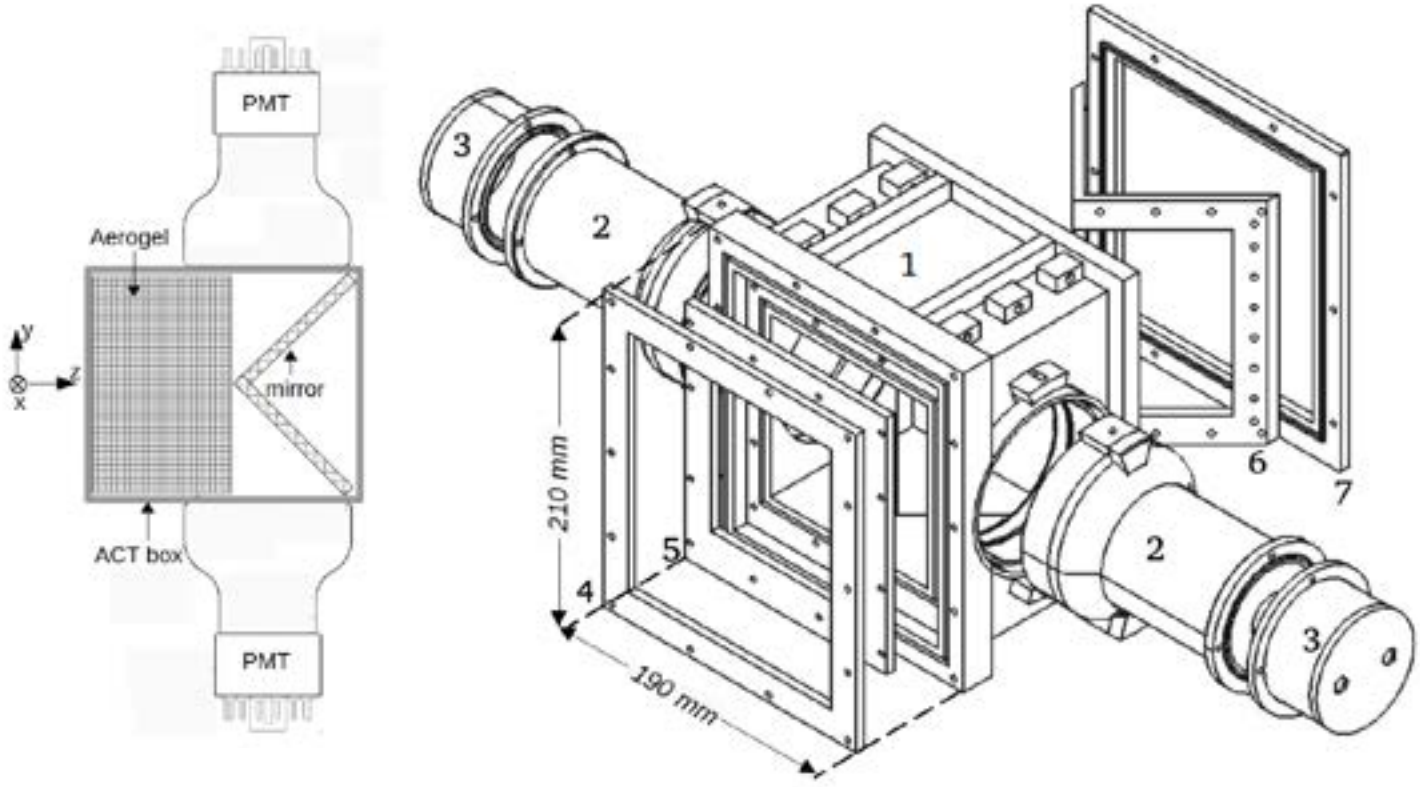
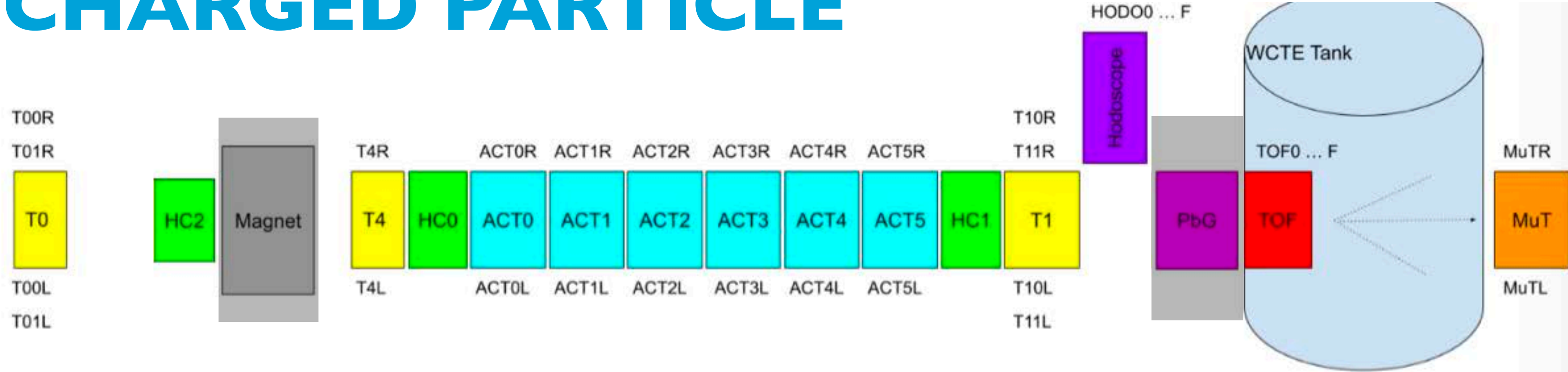

▶ ACT refractive index of ACTs ranges from 1.01 to 1.15

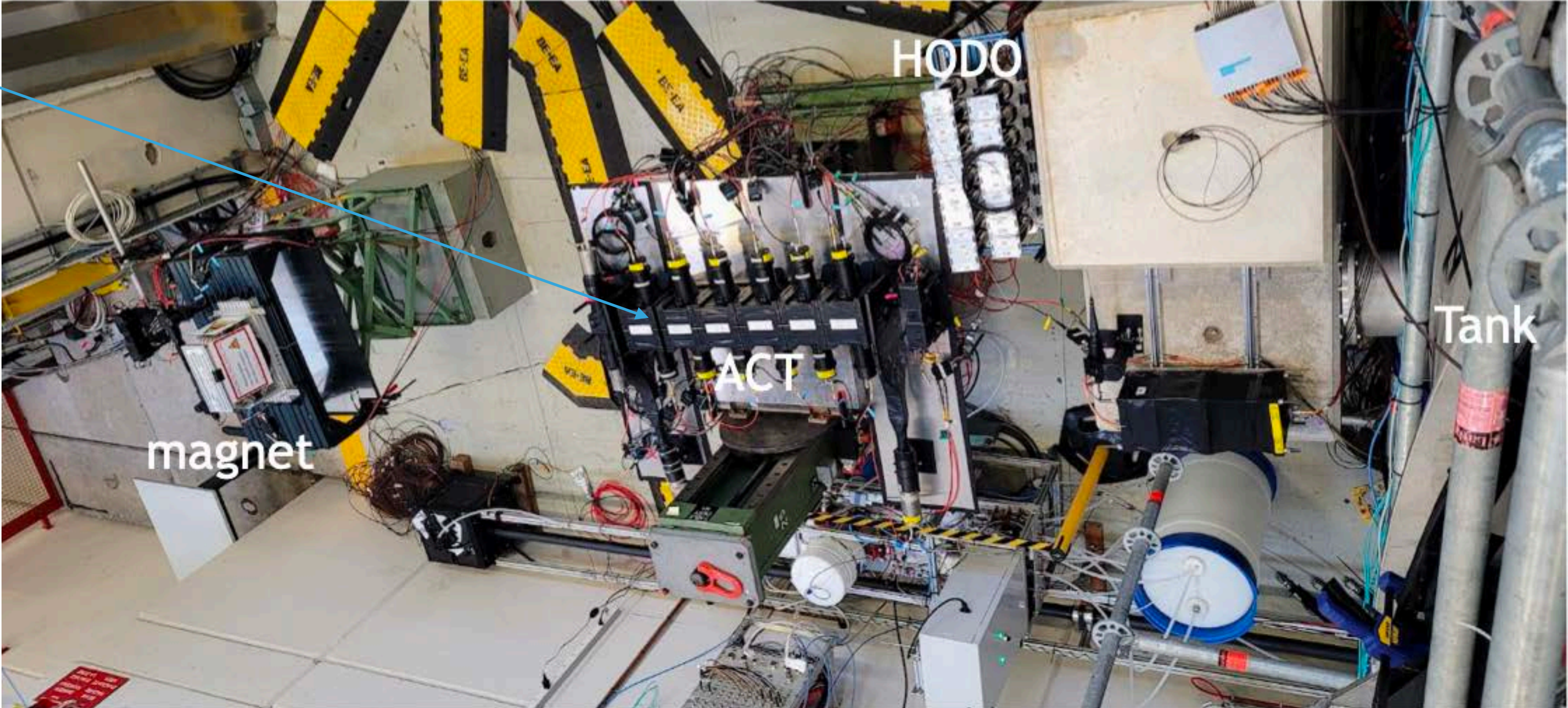

# BEAM DETECTORS - CHARGED PARTICLE

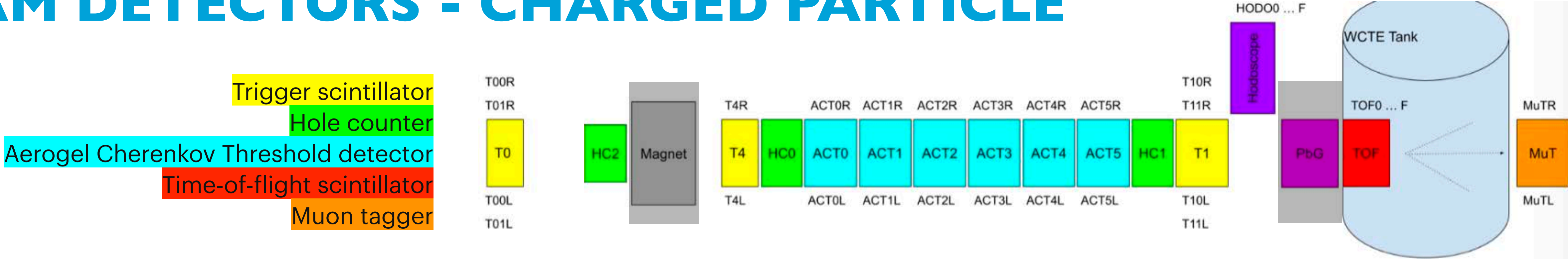

Charged particle separation

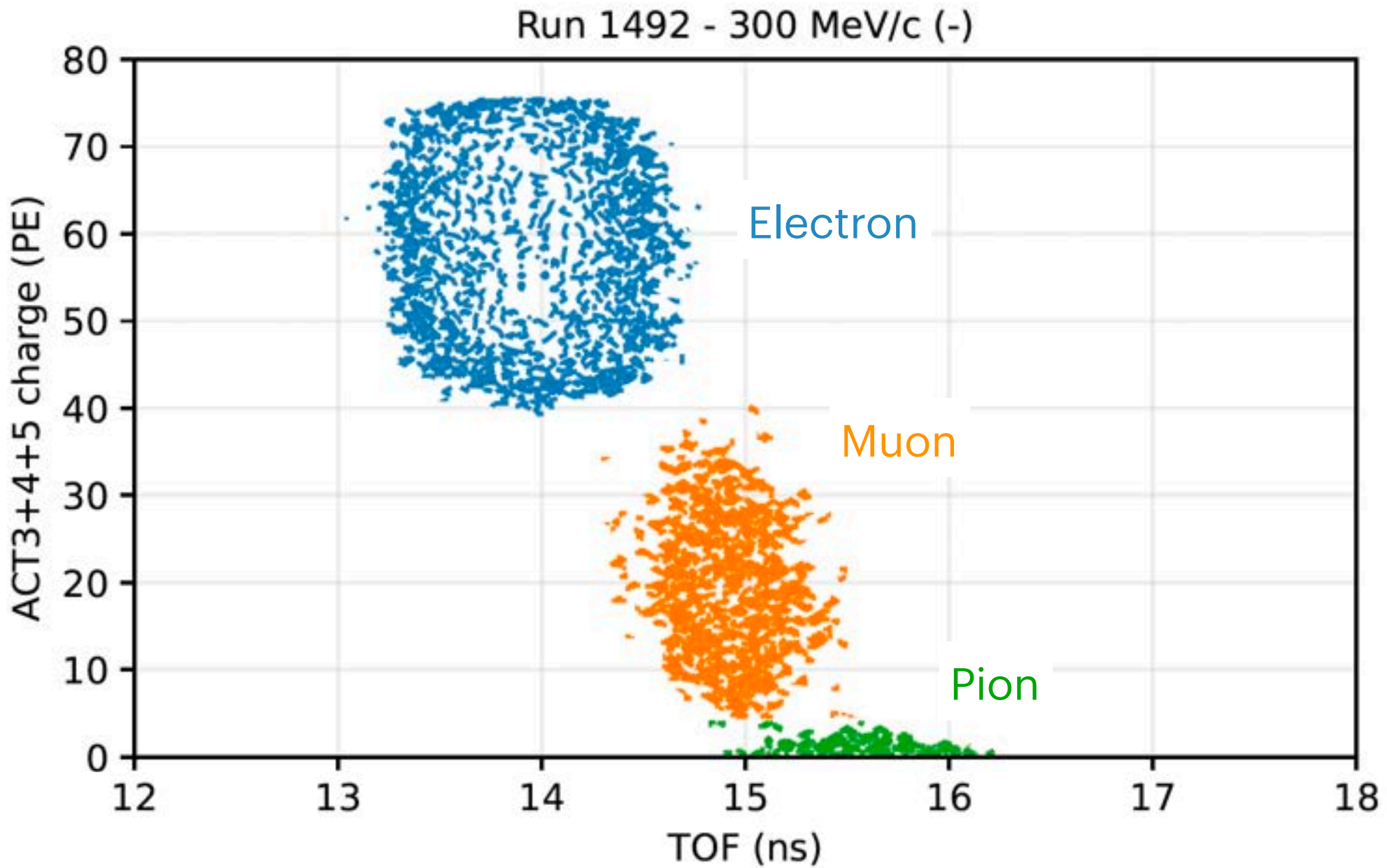

CERN T09 particle flux - Positive polarity  
(2% momentum collimator setting)

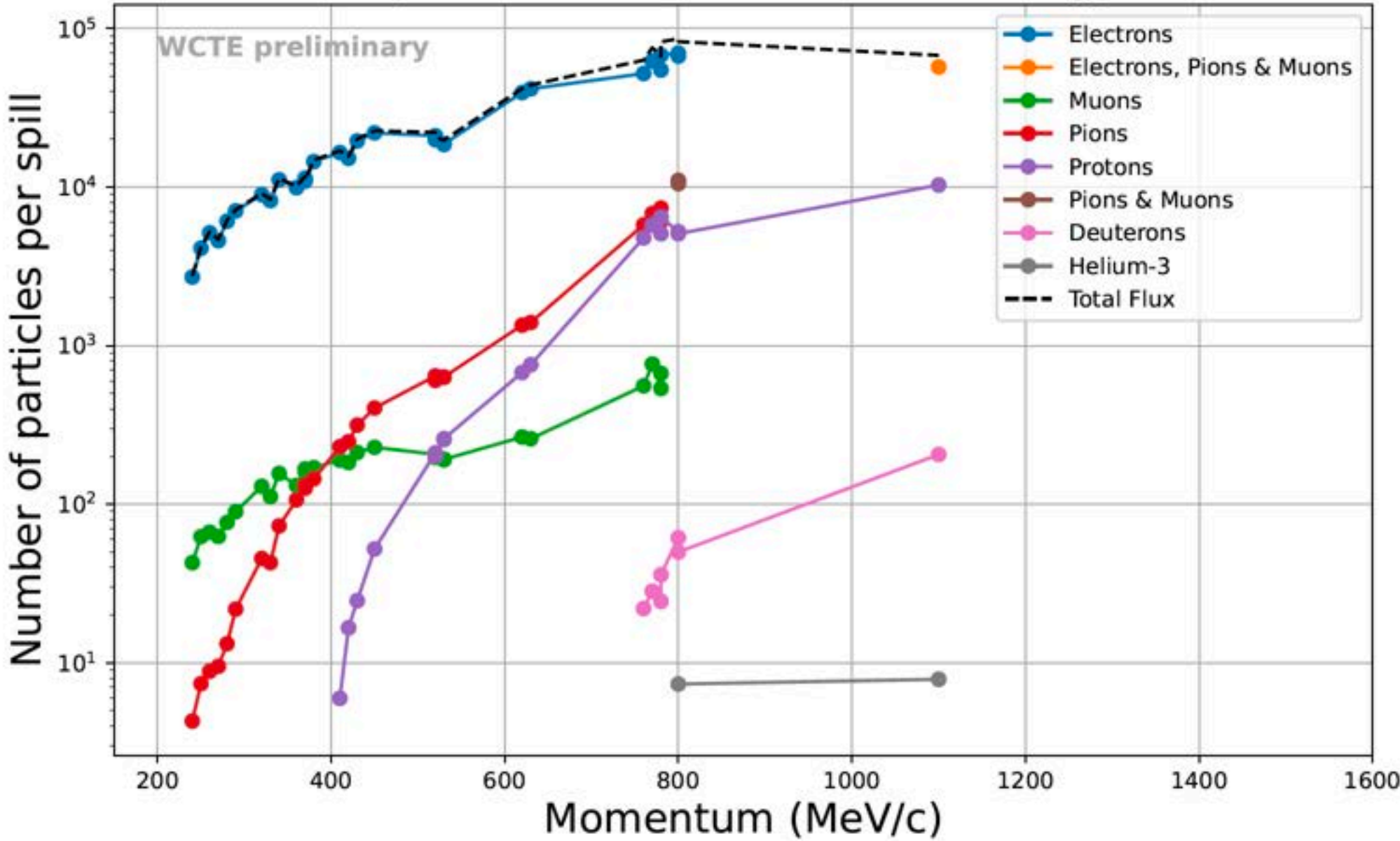

# BEAM DETECTORS - TAGGED PHOTON

- ▶ Electrons that undergo Bremsstrahlung emit gammas along beam direction; gamma energy inferred from electron trajectory after it is bent by permanent magnet
- ▶ Beam momentum is calibrated using time-of-flight measurements
- ▶ Magnet/hodoscope spectrometer response is calibrated with beam

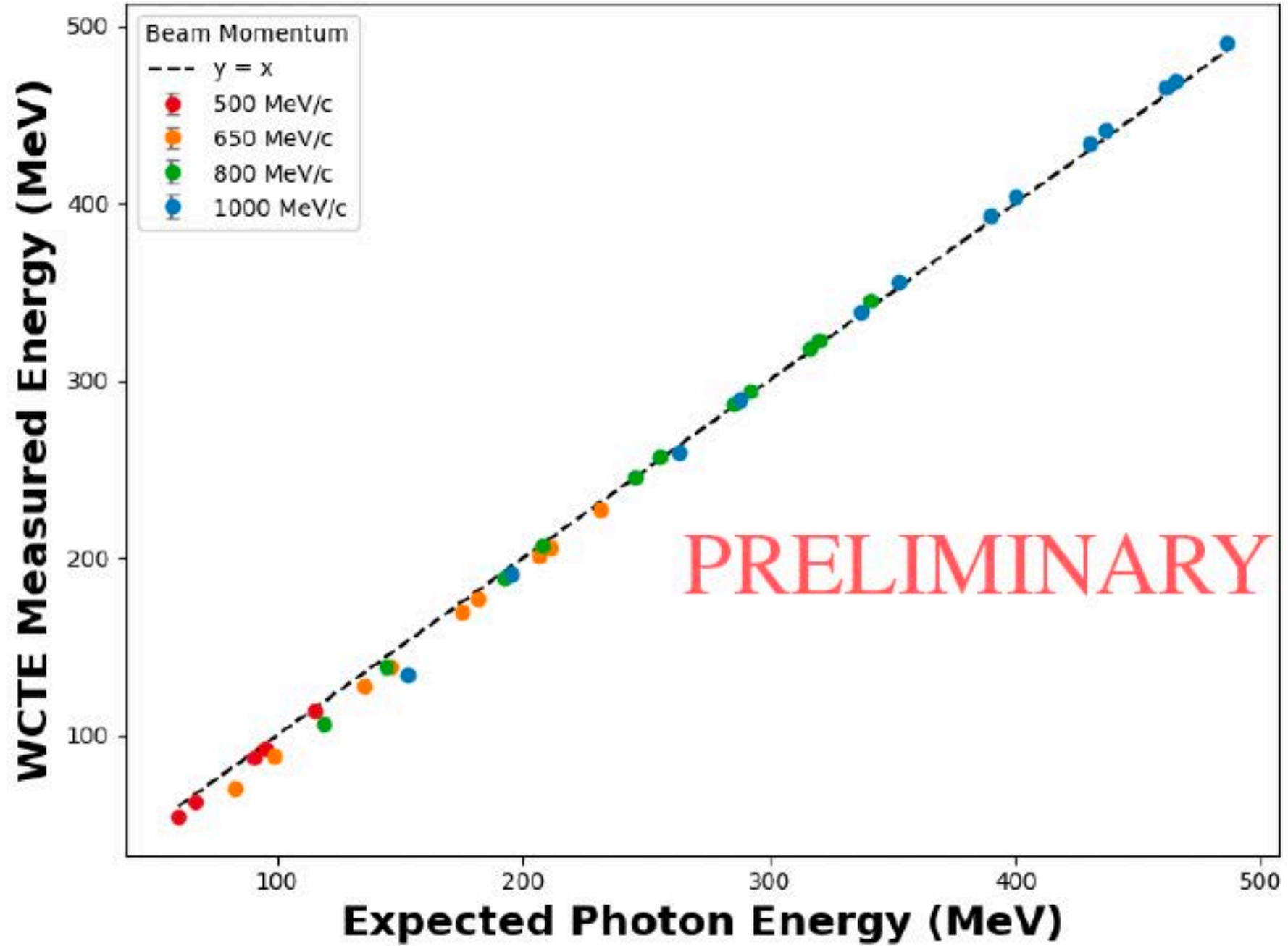
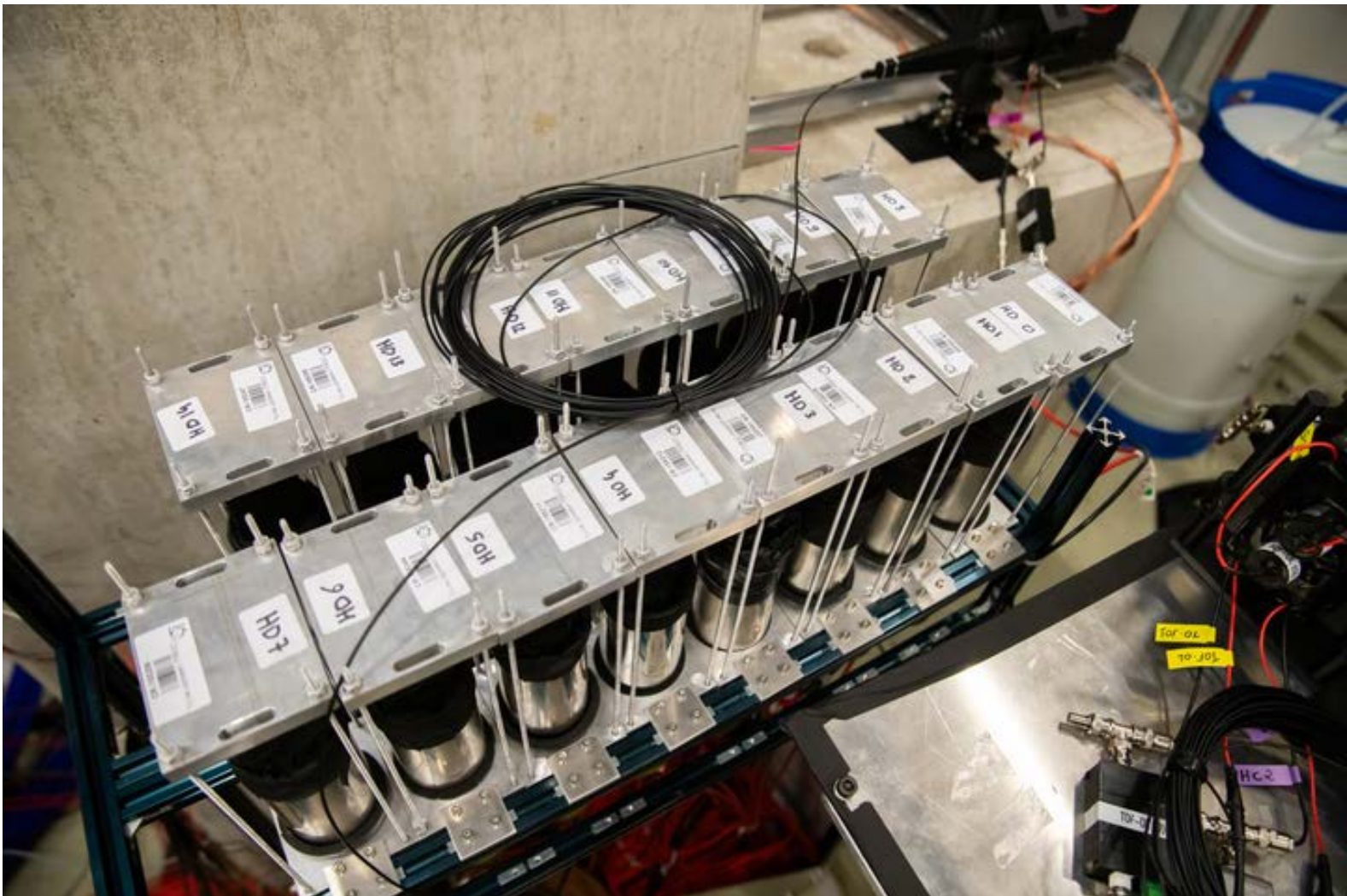
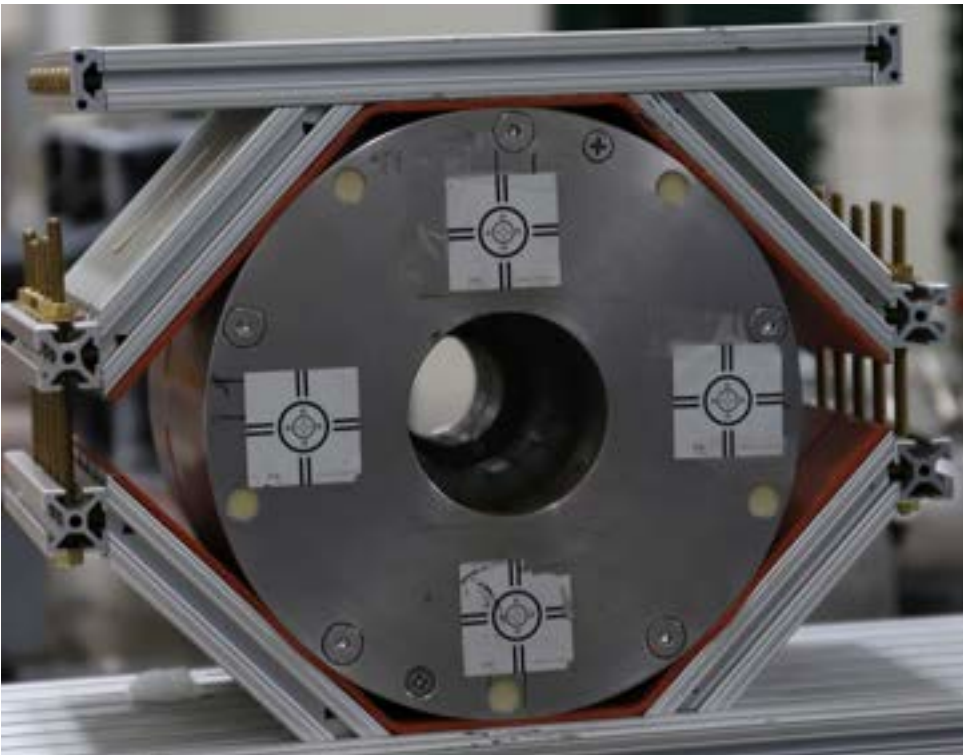
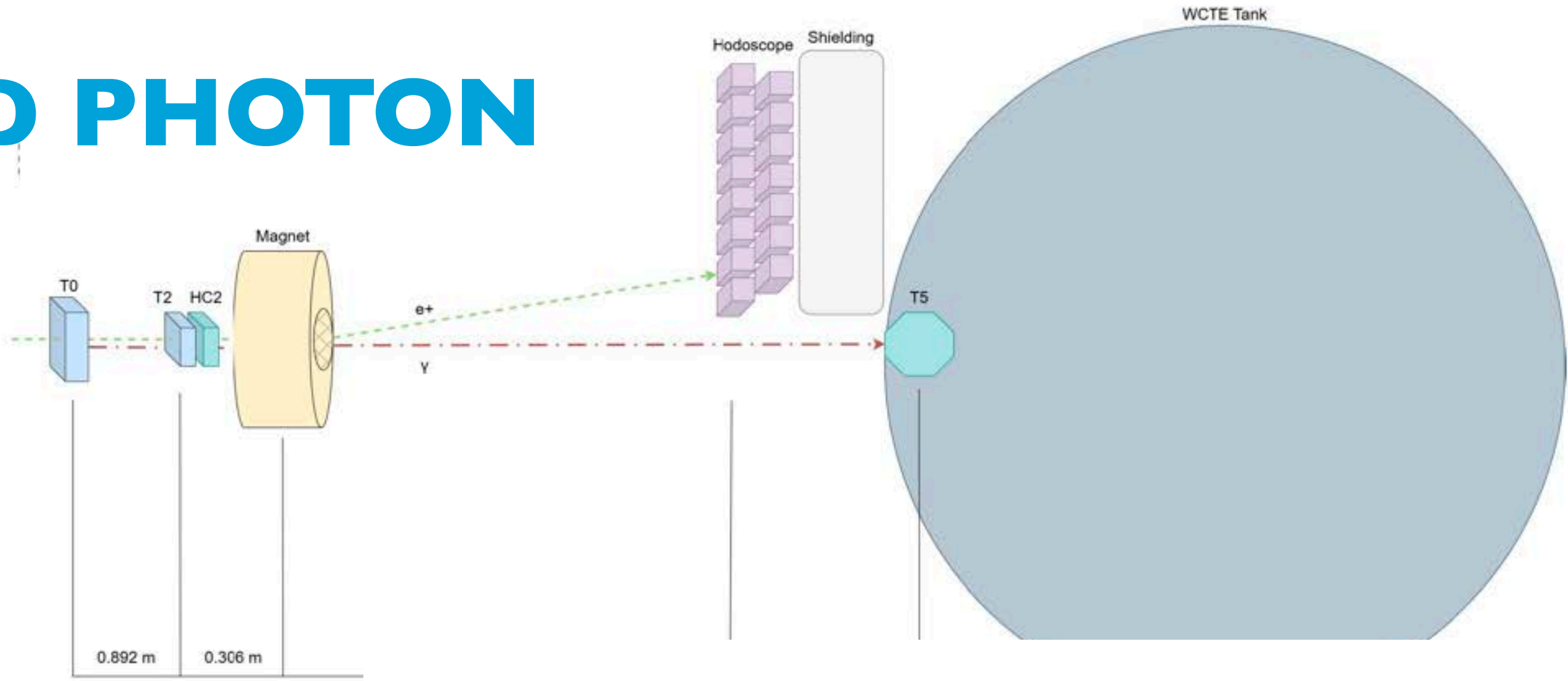

# MULTI PMT (MPMT)

Ex-situ gelling



In-situ gelling

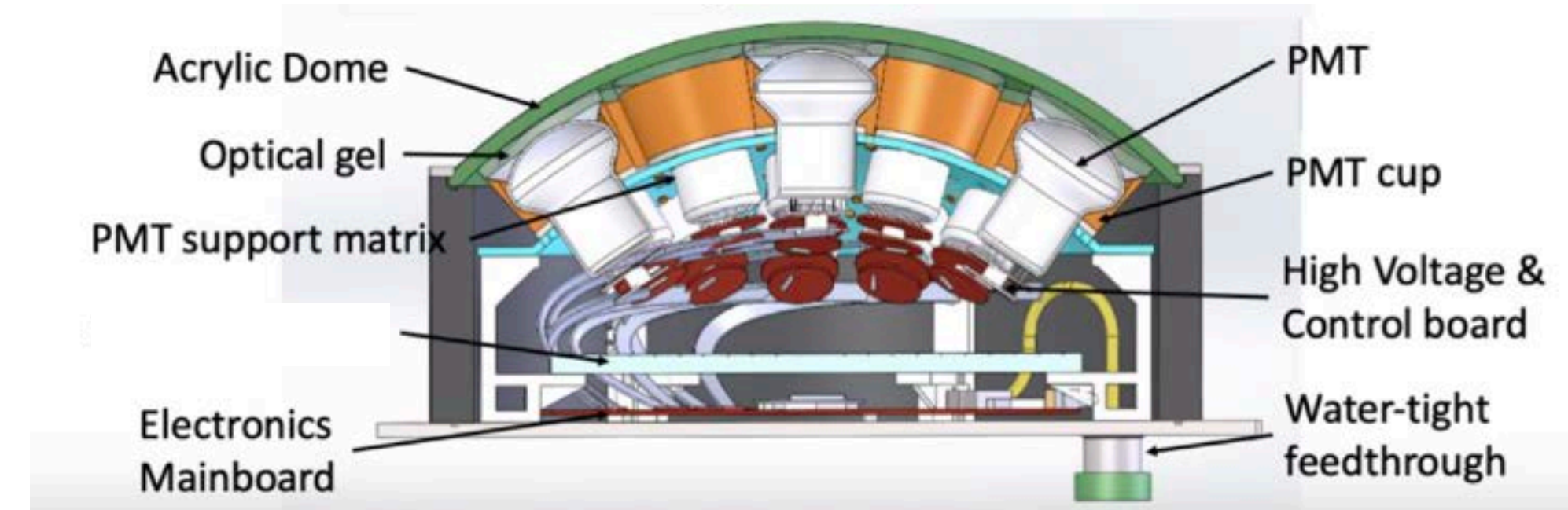

- ▶ Multi-PMT photosensors with good spatial and timing resolution ( $<1$  ns) containing 19 8-cm diameter PMTs and integrated electronics
  - ▶ Power and communication on a single PoE cable
  - ▶ Onboard FPGA for readout control, digital pulse processing and hit packing
- ▶ In-situ gelling method will be used for IWCD mPMTs

Rob Collister's talk on far detector mPMT

# MPMT TRIGGERING

- ▶ Three different modes of mPMT readout triggering were used
  - ▶ “Software trigger”: mPMTs are instructed to read out data at a specified time in the future

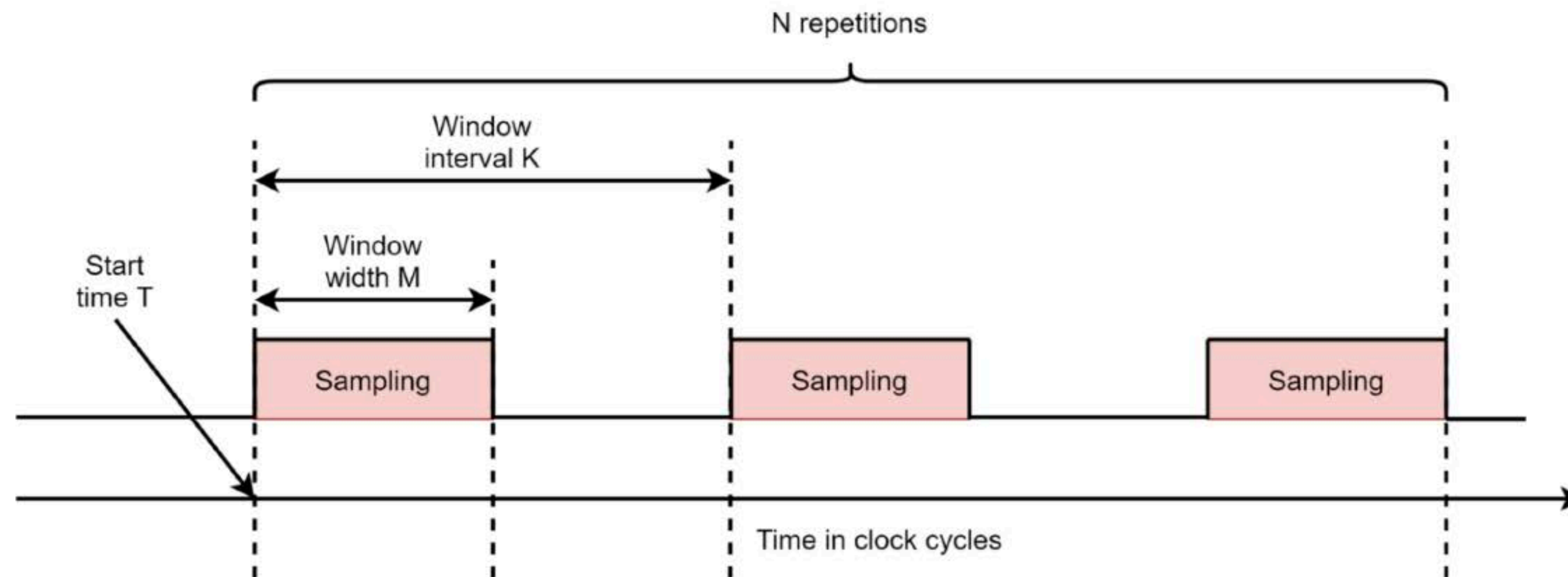

# MPMT TRIGGERING

- ▶ Three different modes of mPMT readout triggering were used
  - ▶ “Software trigger”: mPMTs are instructed to read out data at a specified time in the future
  - ▶ Self trigger: each PMT channel is read out when it goes over a pre-defined threshold

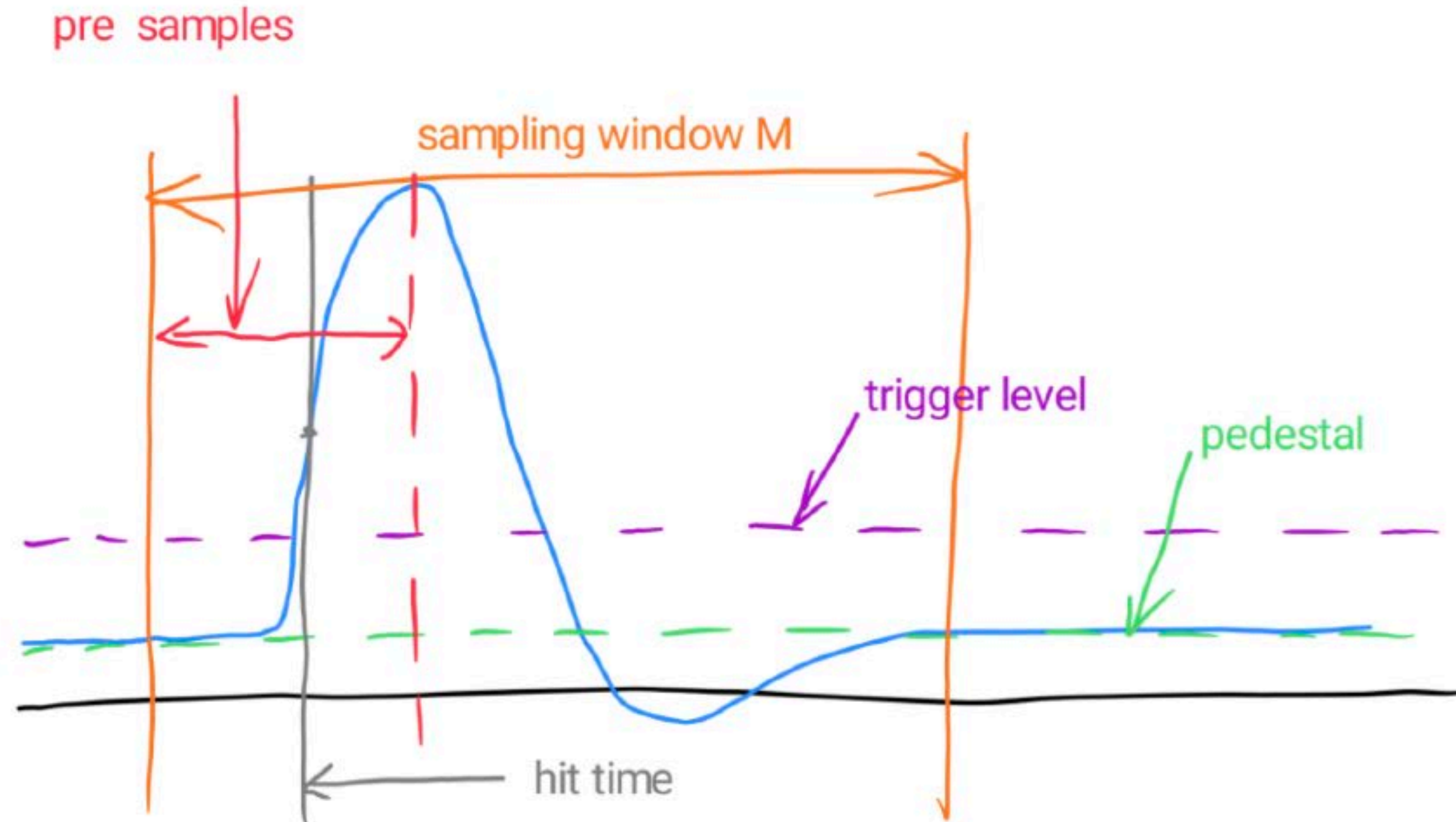

- ▶ “Event building” is done online
  - ▶ Beam events with long read-out window
  - ▶ Cosmic muon and radioactive calibration source

# MPMT TRIGGERING

- ▶ Three different modes of mPMT readout triggering were used
  - ▶ “Software trigger”: mPMTs are instructed to read out data at a specified time in the future
  - ▶ Self trigger: each PMT channel is read out when it goes over a pre-defined threshold
  - ▶ External trigger (aka hardware trigger): a trigger based on the beam monitor information or ext. trigger is distributed to all mPMTs, and the mPMTs send the digitized waveform of all PMT around the time of the trigger
- ▶ **This is the mode in which IWCD will take beam neutrino data**

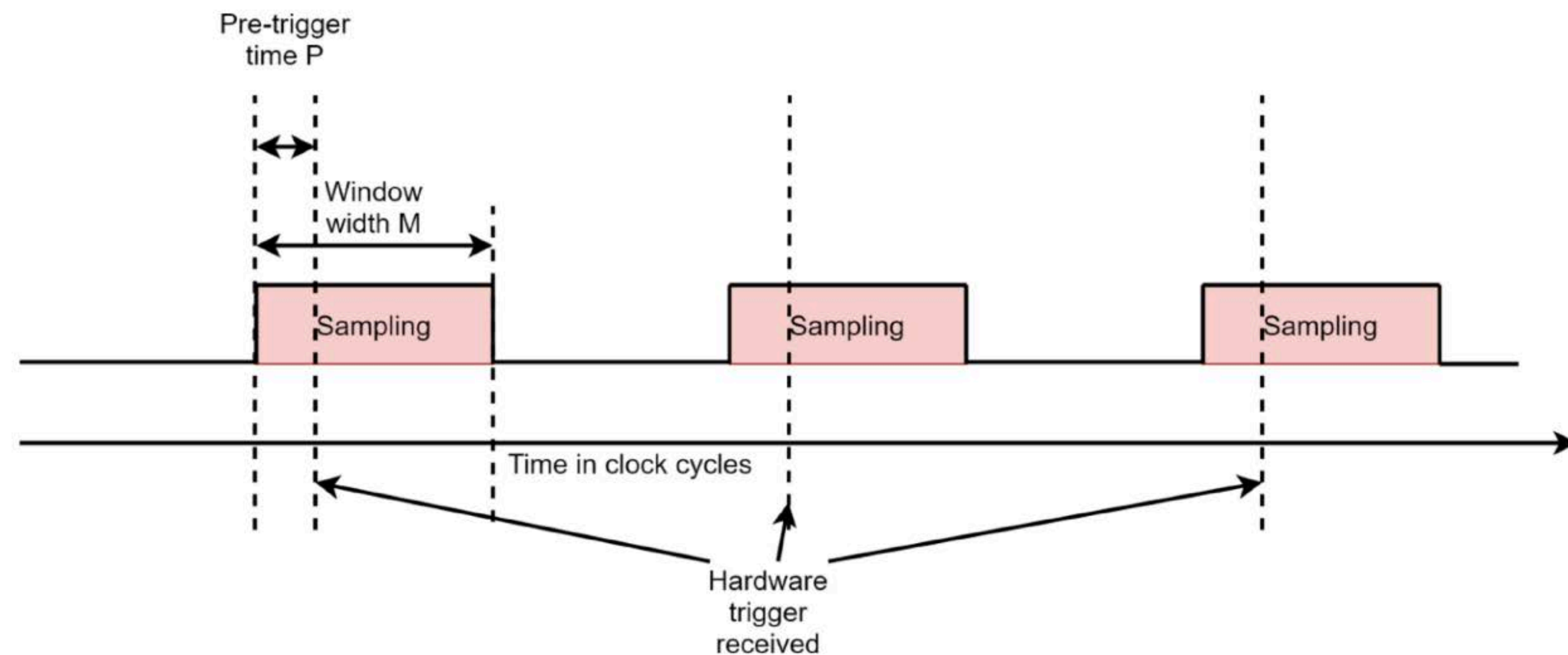

High-rate beam data and laser ball calibration data

# MPMT TRIGGERING

- ▶ Three different modes of mPMT readout triggering were used
  - ▶ “Software trigger”: mPMTs are instructed to read out data at a specified time in the future
  - ▶ Self trigger: each PMT channel is read out when it goes over a pre-defined threshold
  - ▶ External trigger (aka hardware trigger): a trigger based on the beam monitor information (or ext. trigger) is distributed to all mPMTs, and the mPMTs send the digitized waveform of all PMT around the time of the trigger
- ▶ Separately, 3 repurposed mPMT electronics mainboards are used in WCTE for beam detectors readout
  - ▶ This led to the idea of using these digitizer boards for the IWCD outer detector PMT readout

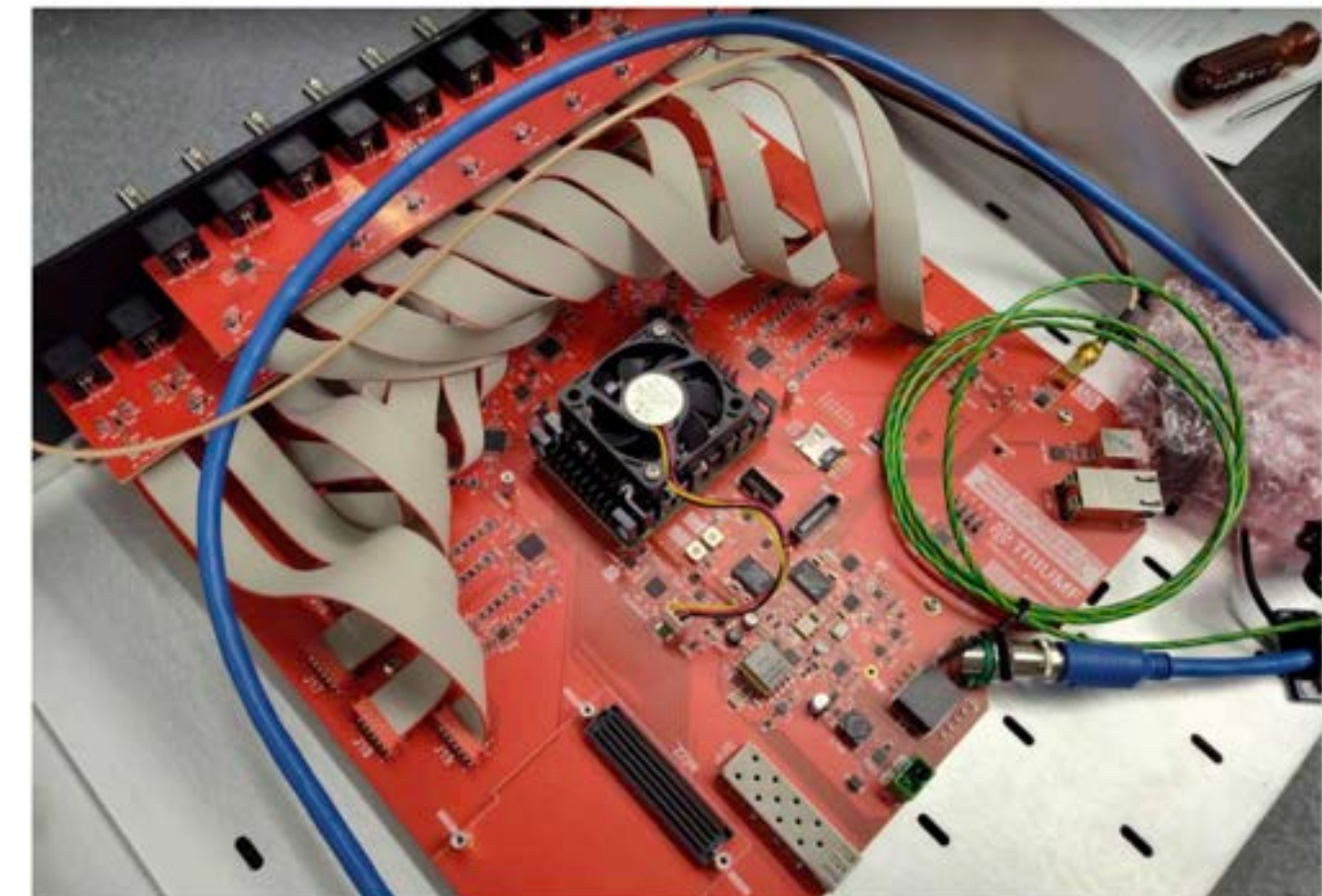

# DETECTOR CALIBRATION

- ▶ Central deployment system (CDS)
  - ▶ Laser diffuser ball, **Ni/Cf** (gamma source), AmBe+BGO (neutron source)
- ▶ **Pulsed LEDs** in mPMT
- ▶ **Photogrammetry** camera X 8
- ▶ **Cosmic muon**
- ▶ Ex-situ measurement of black sheet reflectance (not shown)
- ▶ **Water monitoring system (WMS)** and Gadolinium Absorbance Detector (GAD) (not shown)

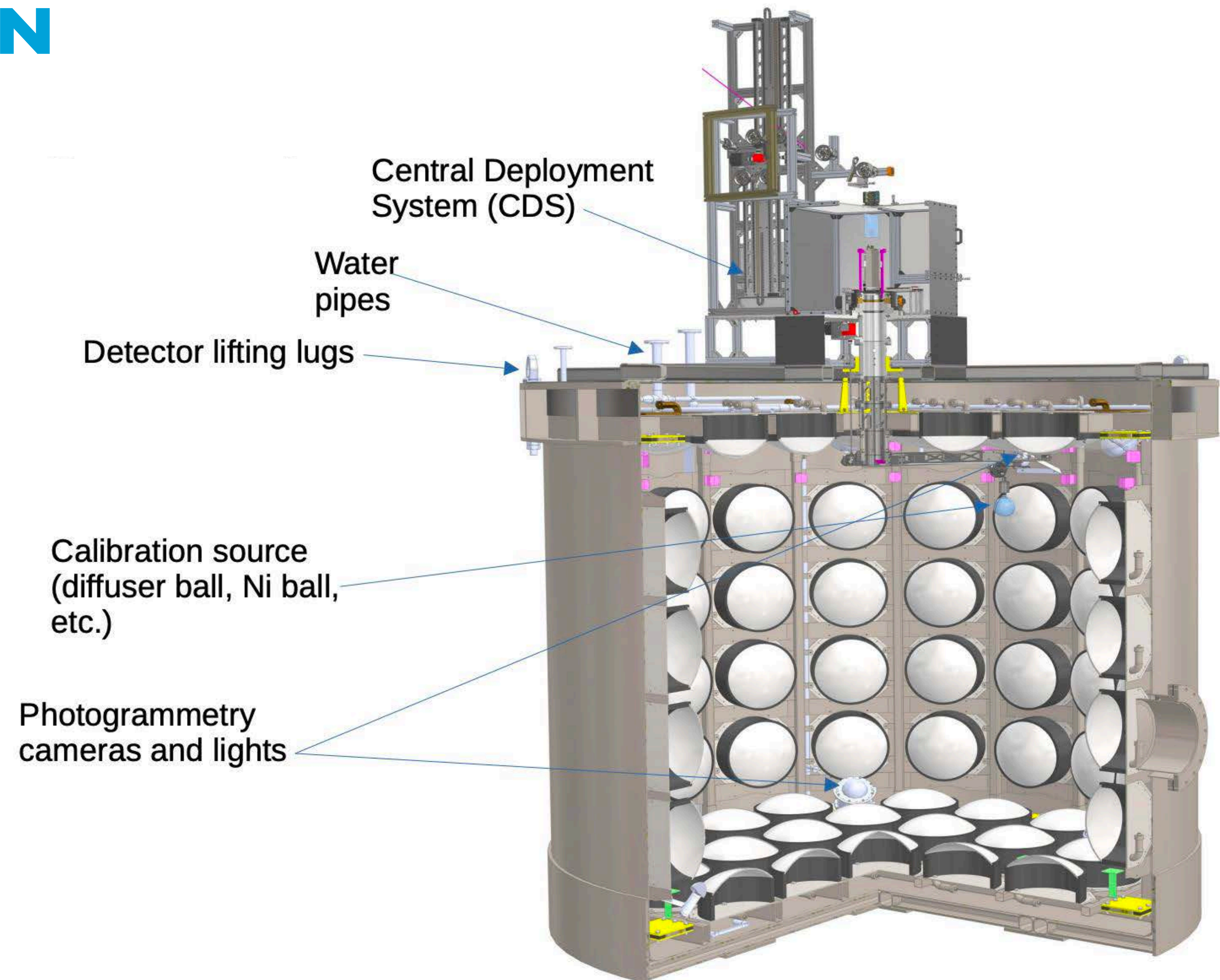

## PULSED LED

- ▶ Three pulsed LEDs at 365 nm, 405 nm, 470 nm in each mPMT
- ▶ Sub-ns pulse width,  $>10^7$  photons/pulse
- ▶ One diffused, two collimated
- ▶ LED mezzanine board inside mPMT with each LED coupled to a light guide
  - ▶ Also 6 continuous LEDs per mPMT as photogrammetry targets
- ▶ Time-of-flight measurements of LED-PMT pairs are used to calibrate the relative timing offset of all PMT channels



3 pulsed LEDs



6 continuous LEDs

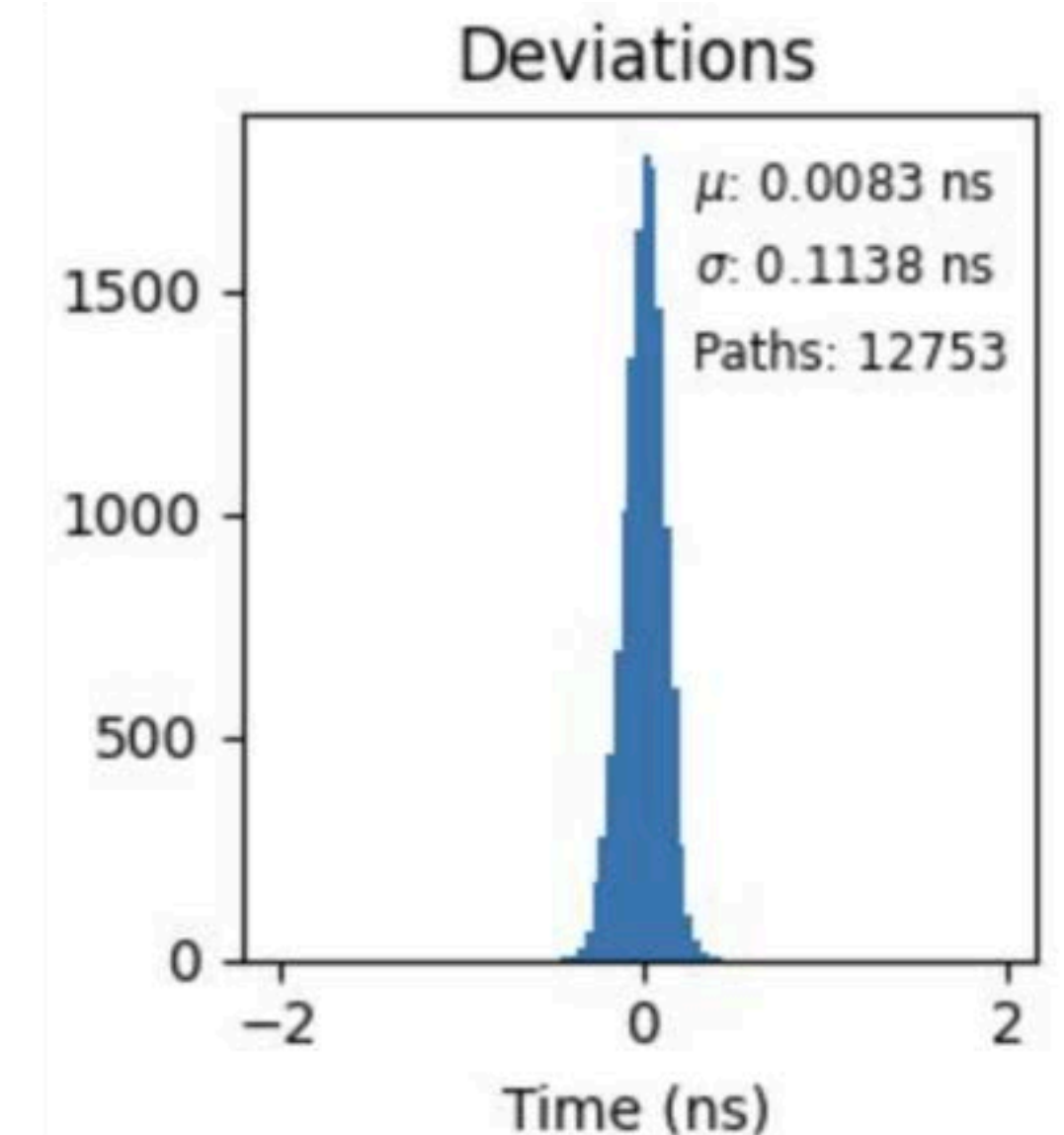
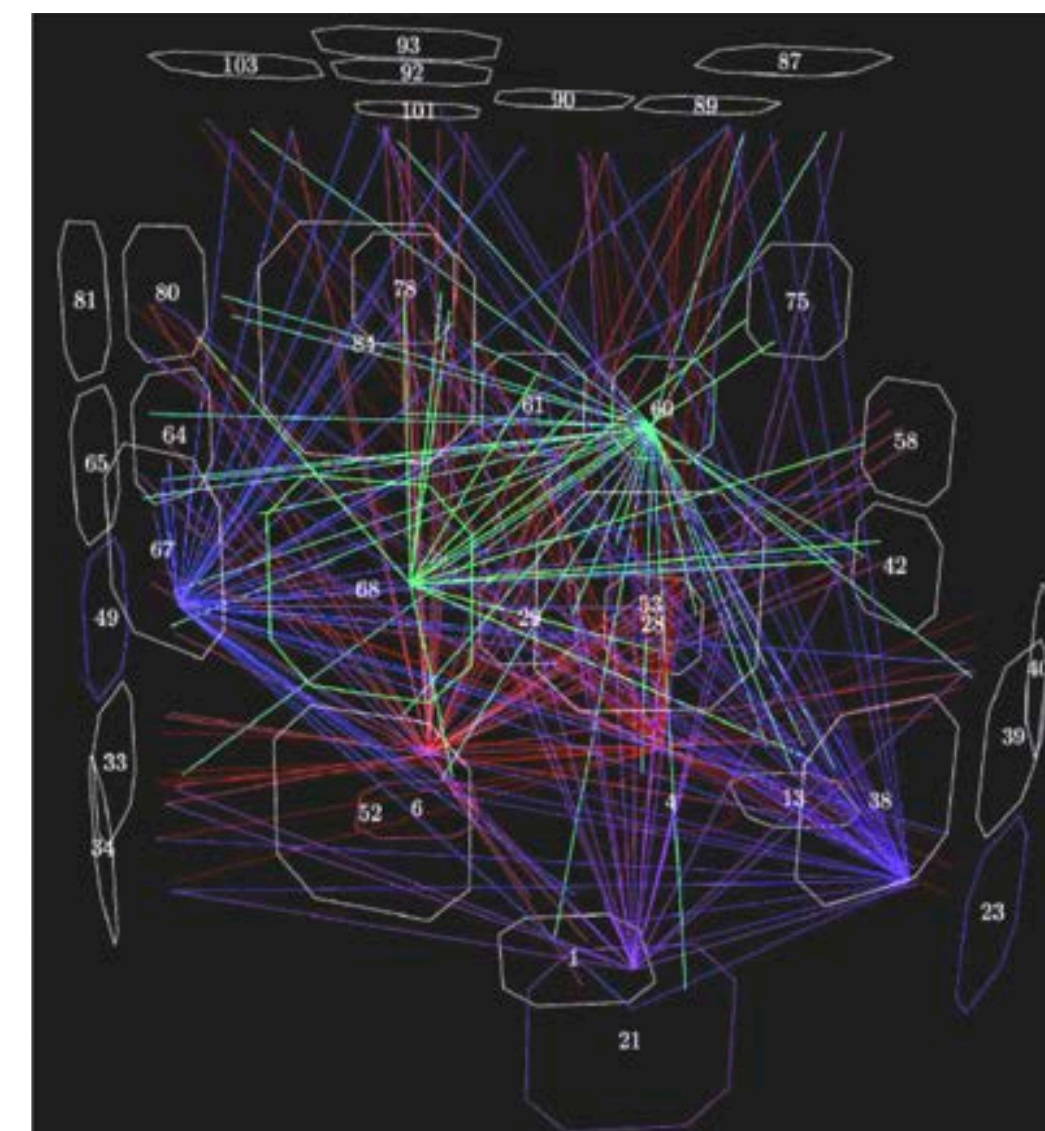

# PMT ANGULAR RESPONSE

- ▶ Diffused LEDs are also used for PMT angular response measurement
- ▶ Identifies mPMT gel delamination
  - ▶ Caused by temperature differential
  - ▶ Fix: overpressure during gelling

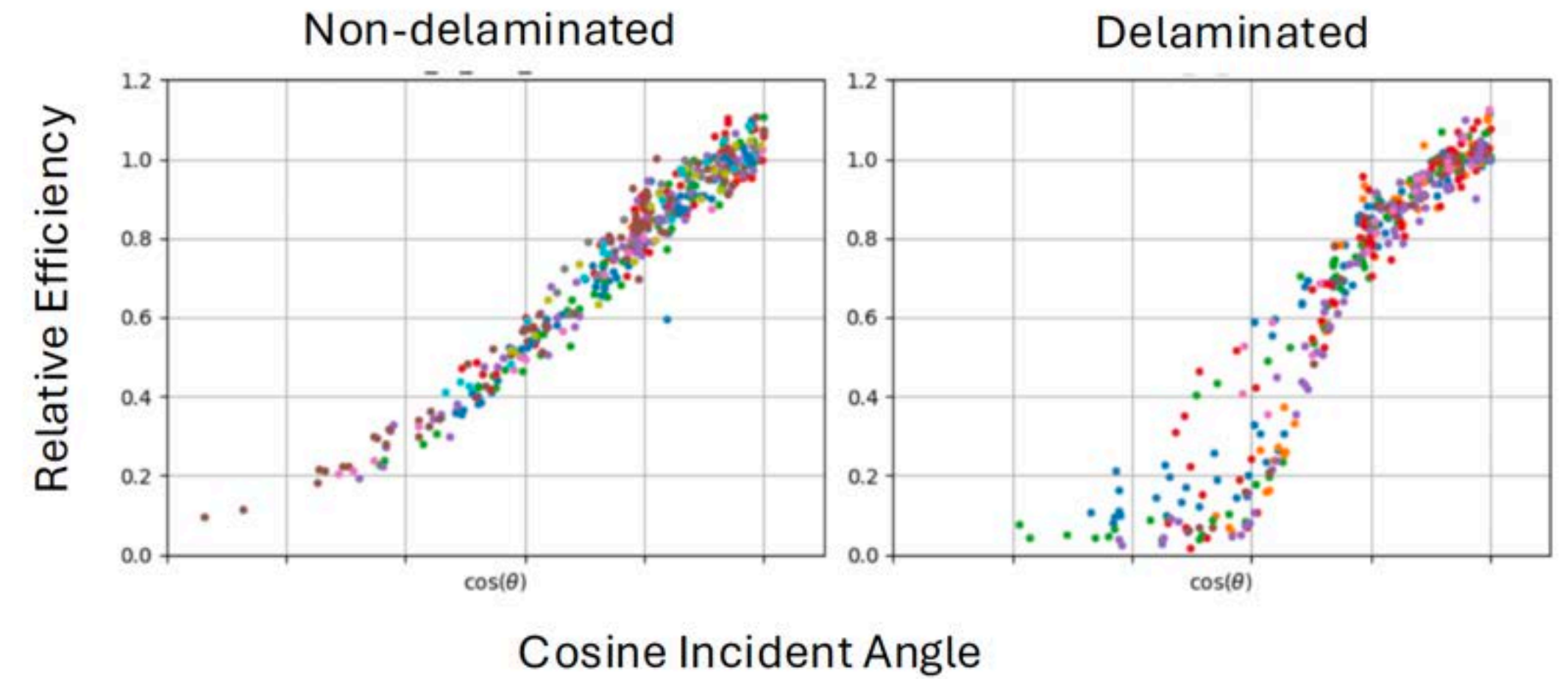
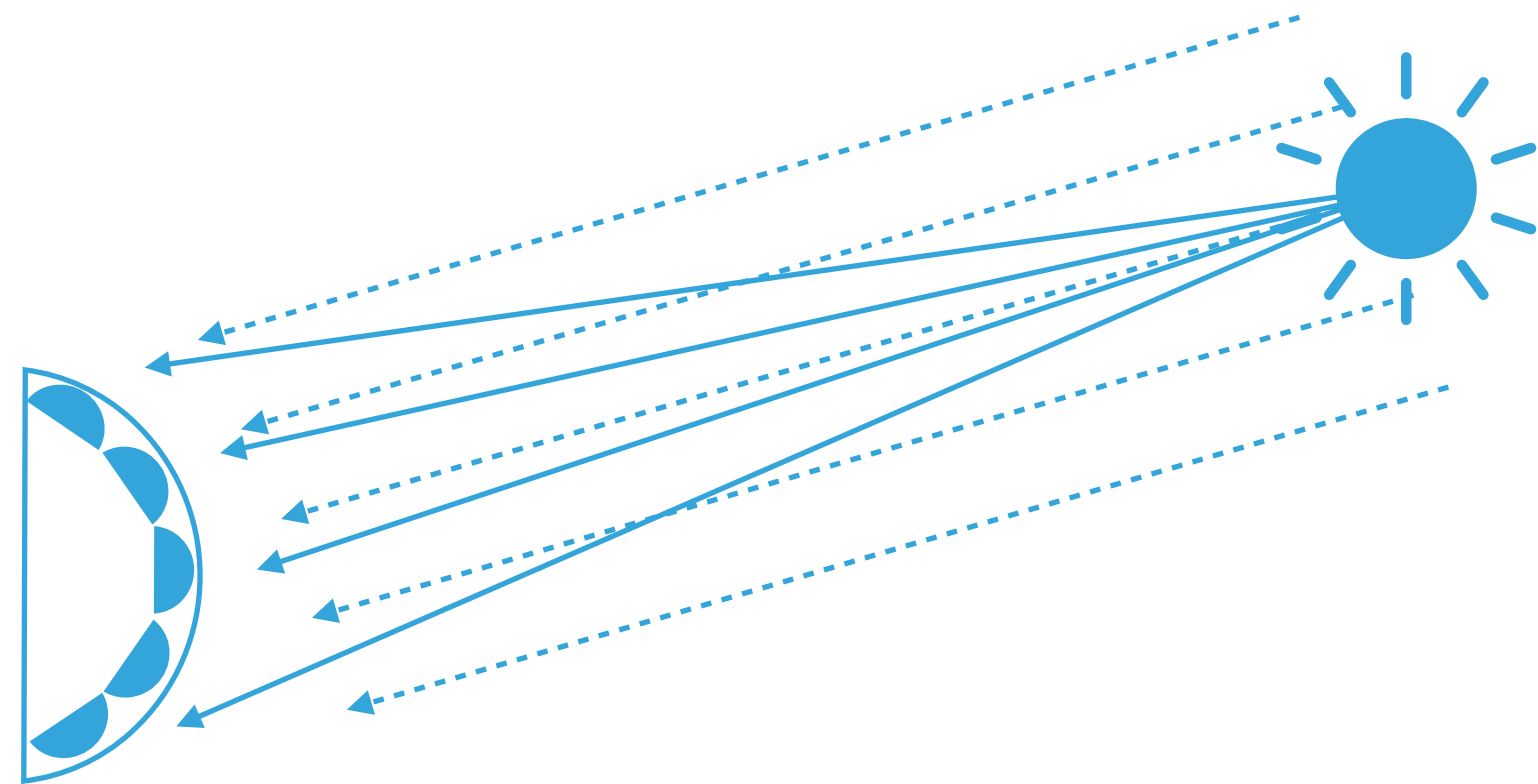

# PMT ANGULAR RESPONSE

- ▶ Diffused LEDs are also used for PMT angular response measurement
  - ▶ Identifies mPMT gel delamination
- ▶ Ni/Cf data and cosmic muon data are also used to measure PMT relative detection efficiency and angular response
  - ▶ Qualitatively similar behaviours, e.g. lower efficiency caused by gel poisoning

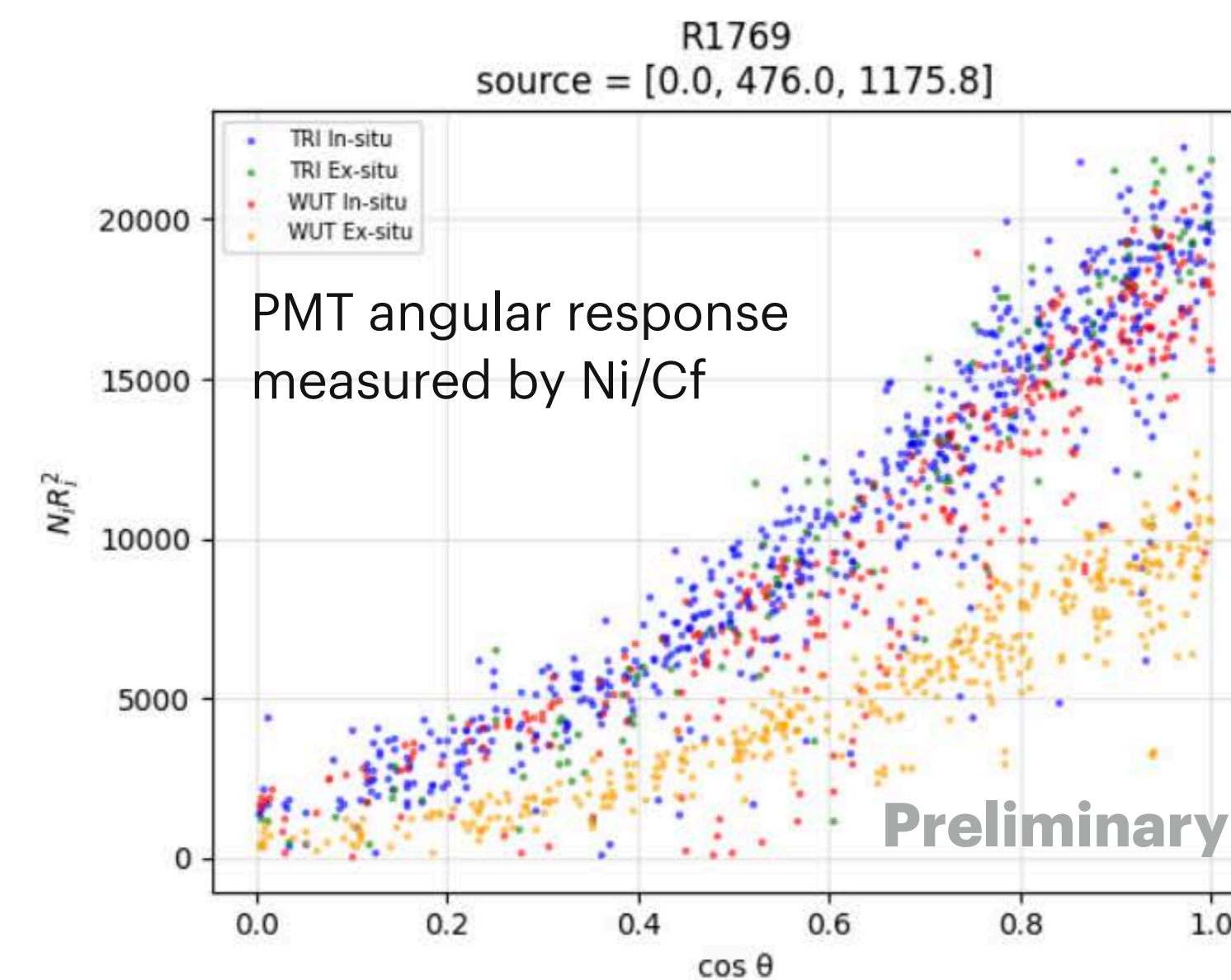
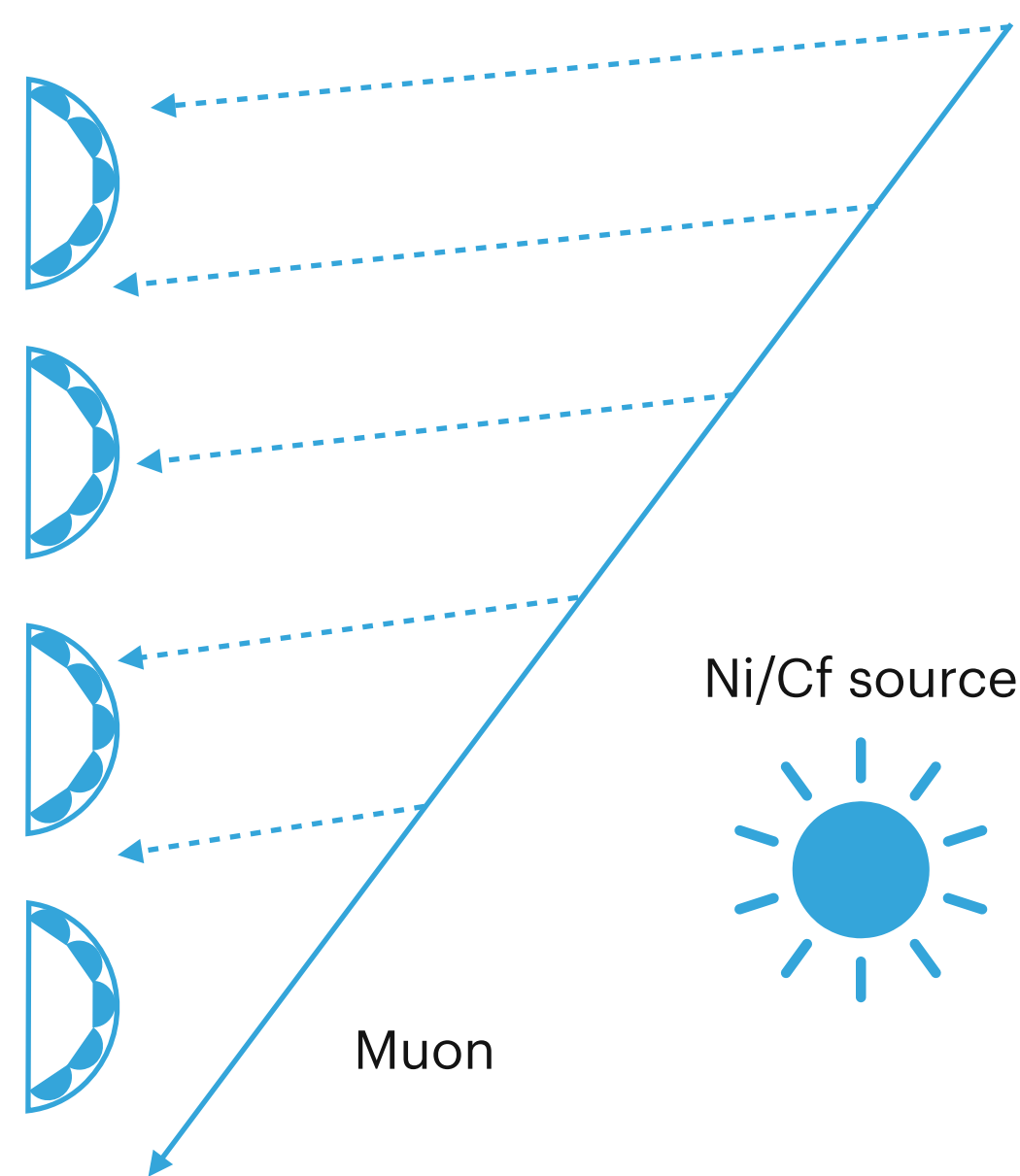
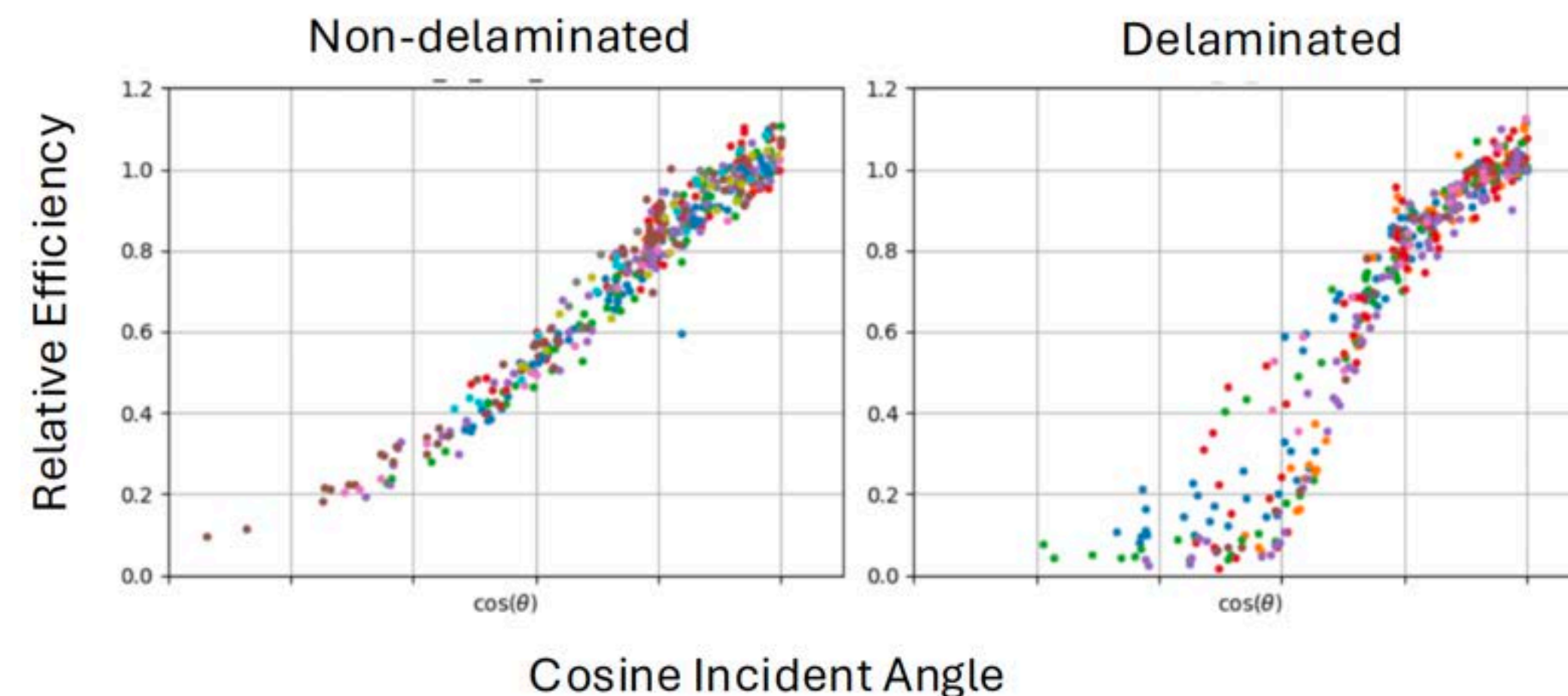

# PHOTOGRAMMETRY SYSTEM

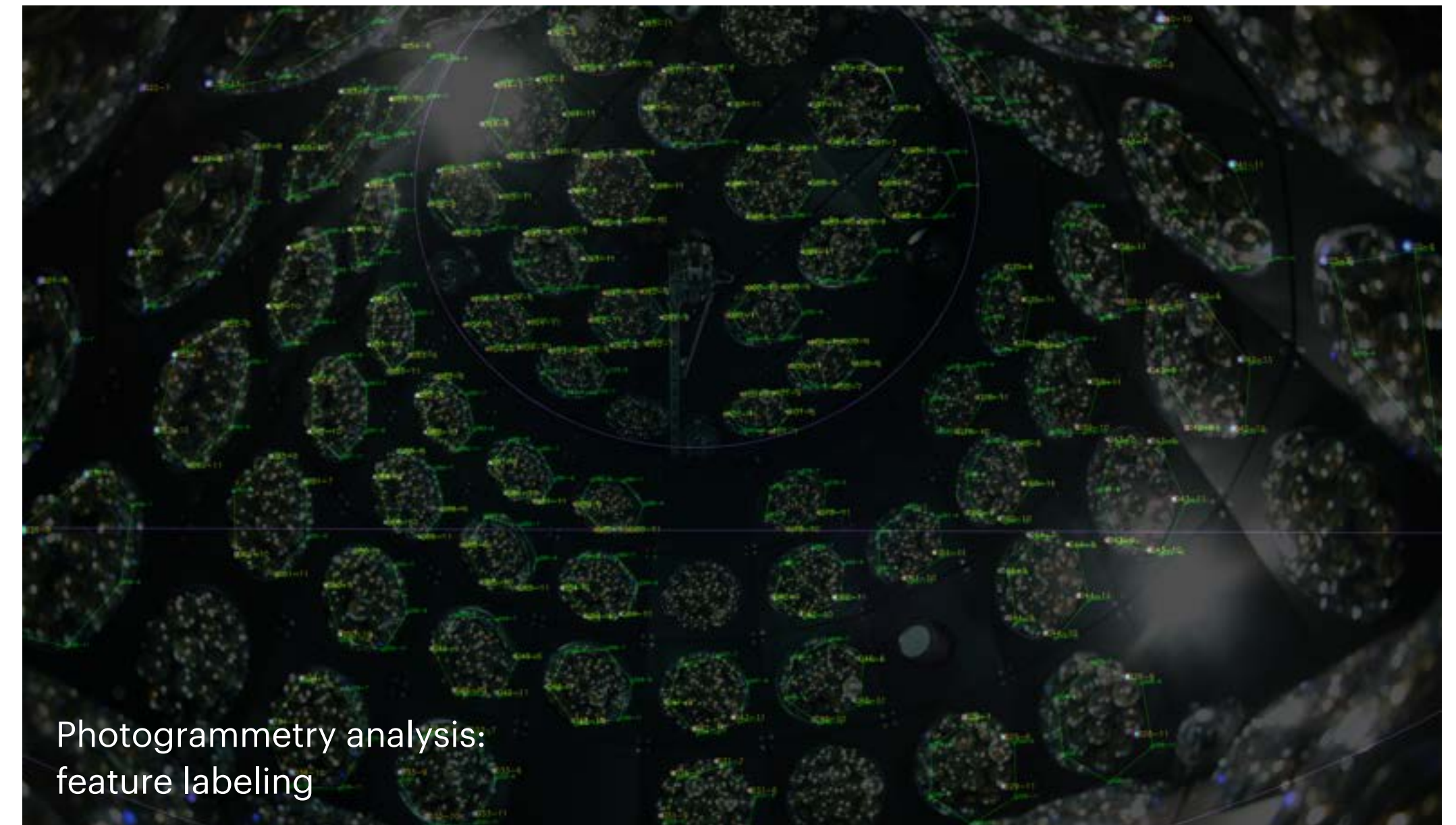
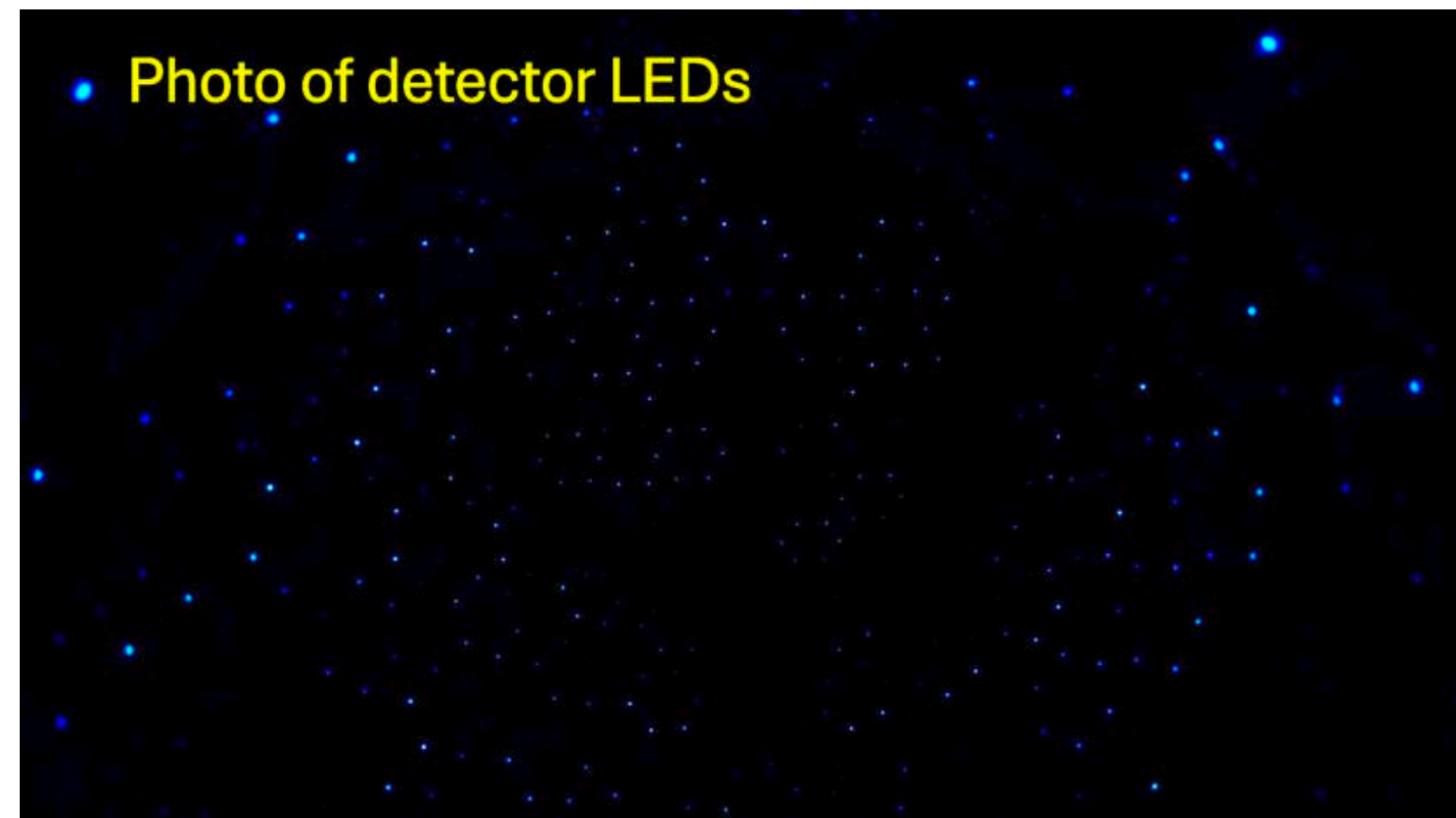
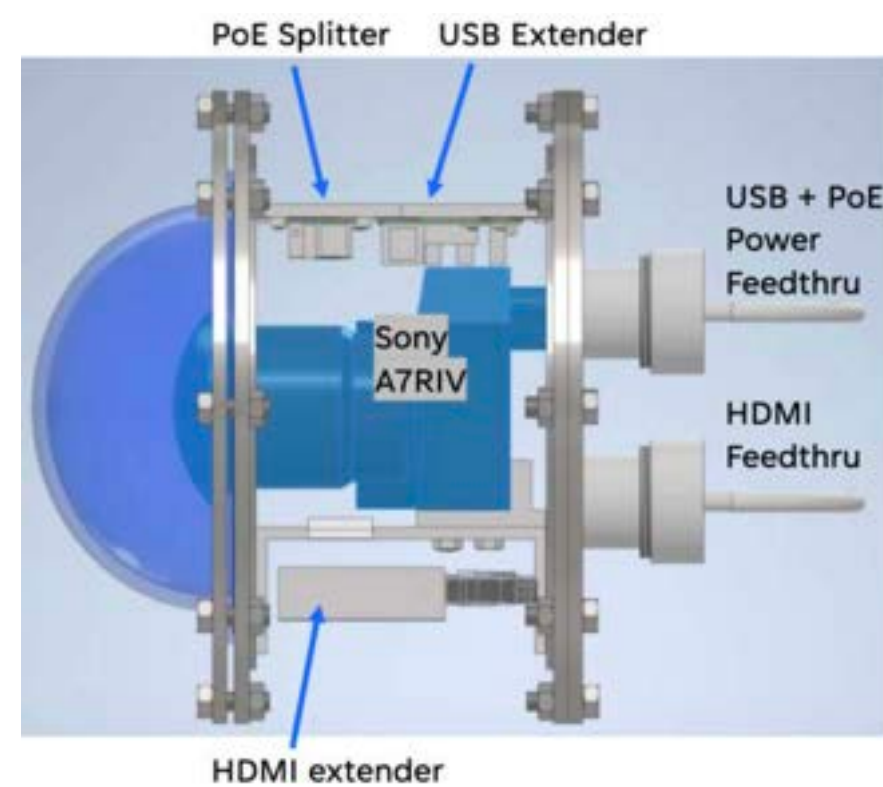

- ▶ 8 fixed cameras used detector geometry measurements after installation
- ▶ Camera parameters are calibrated in-water prior to installation
- ▶ Each feature (continuous mPMT LED) is photographed by multiple cameras; simultaneous fit to feature positions in each camera's frame results in 3D positions of features

# WATER MONITORING SYSTEM

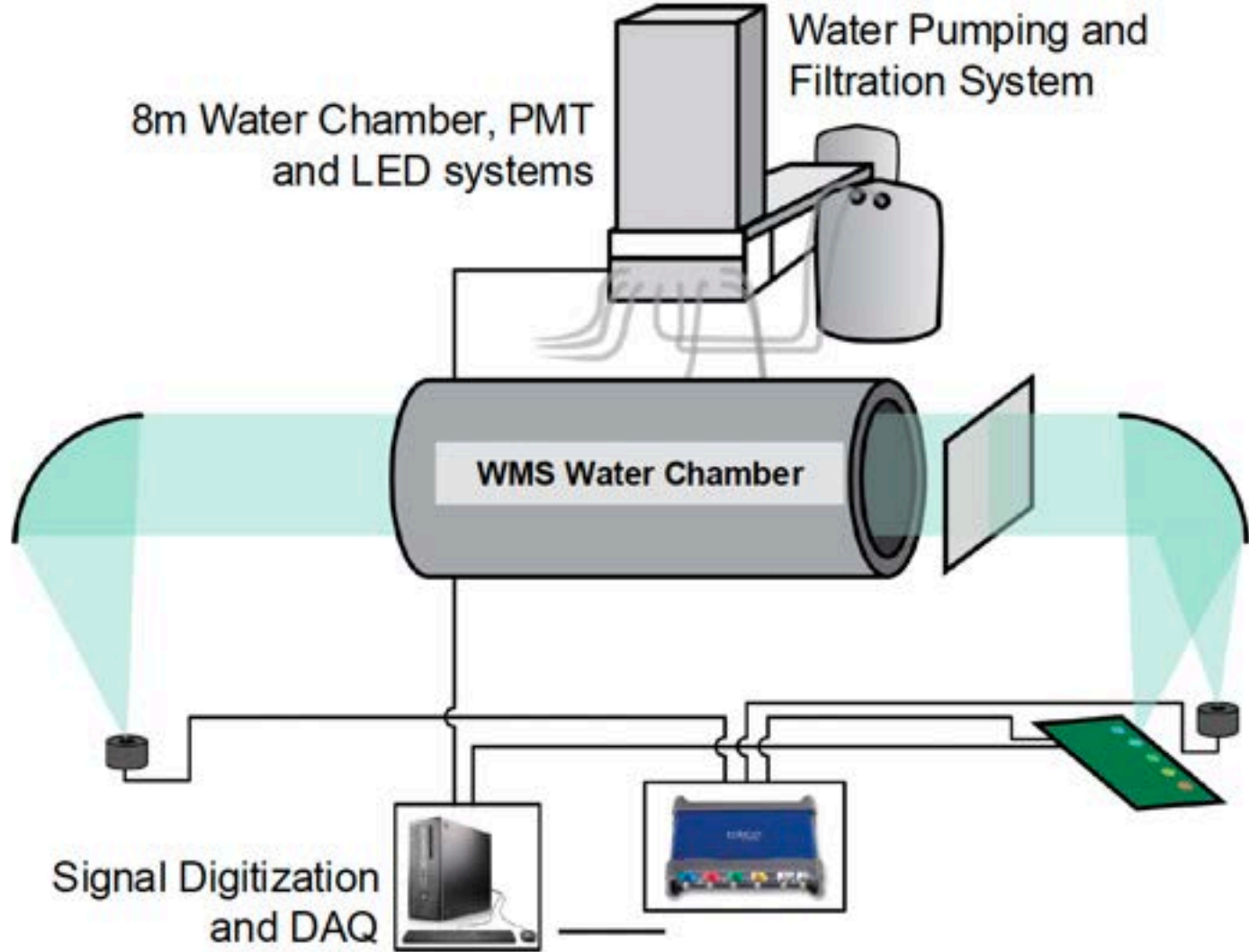

- ▶ Water monitoring system (WMS) demonstrated <1% measurement precision of change in water transparency during WCTE operation
  - ▶ 255 nm - 410 nm; sensitive to organic contaminants
  - ▶ Used to track Gd concentration during Gd injection

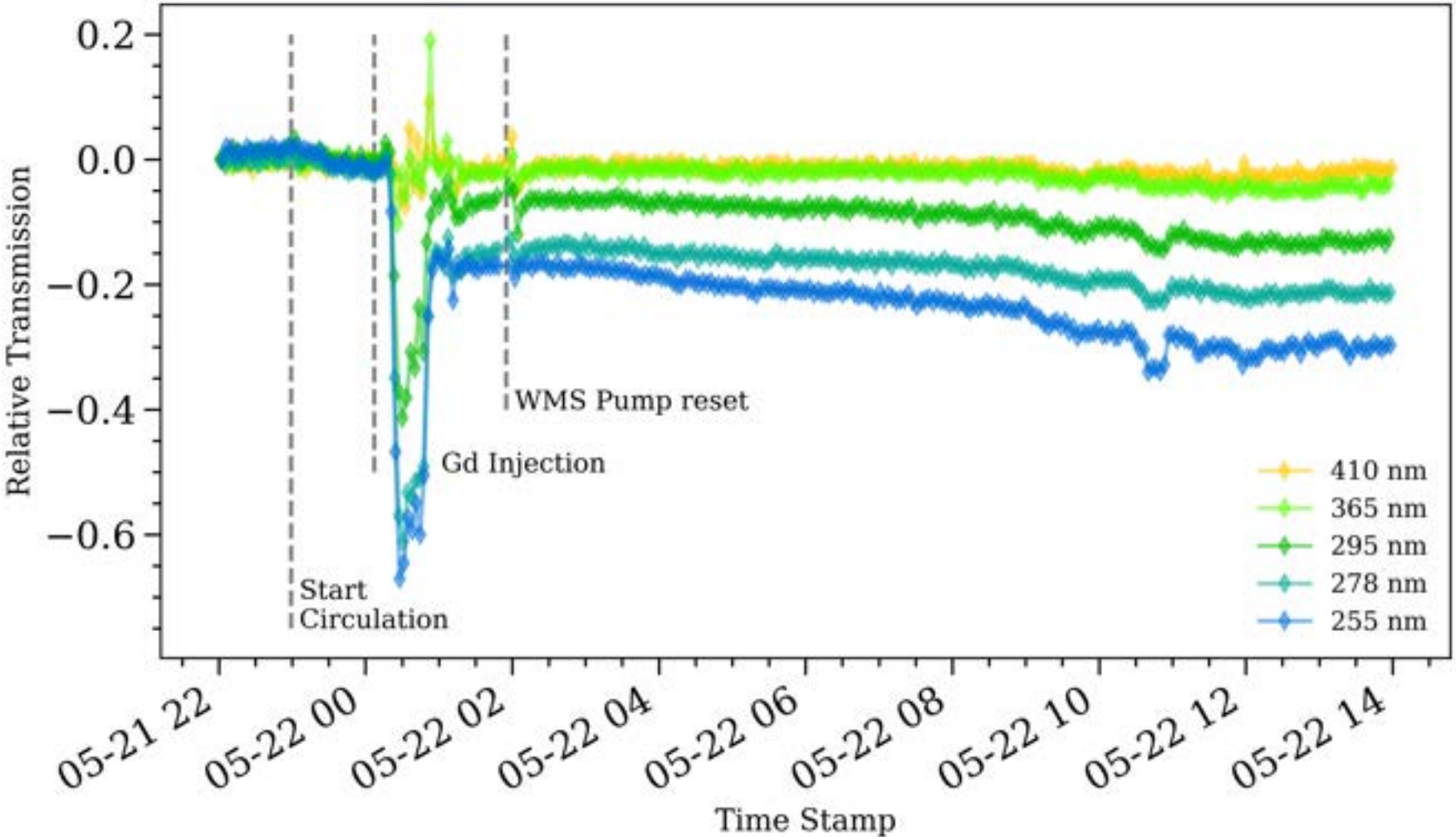
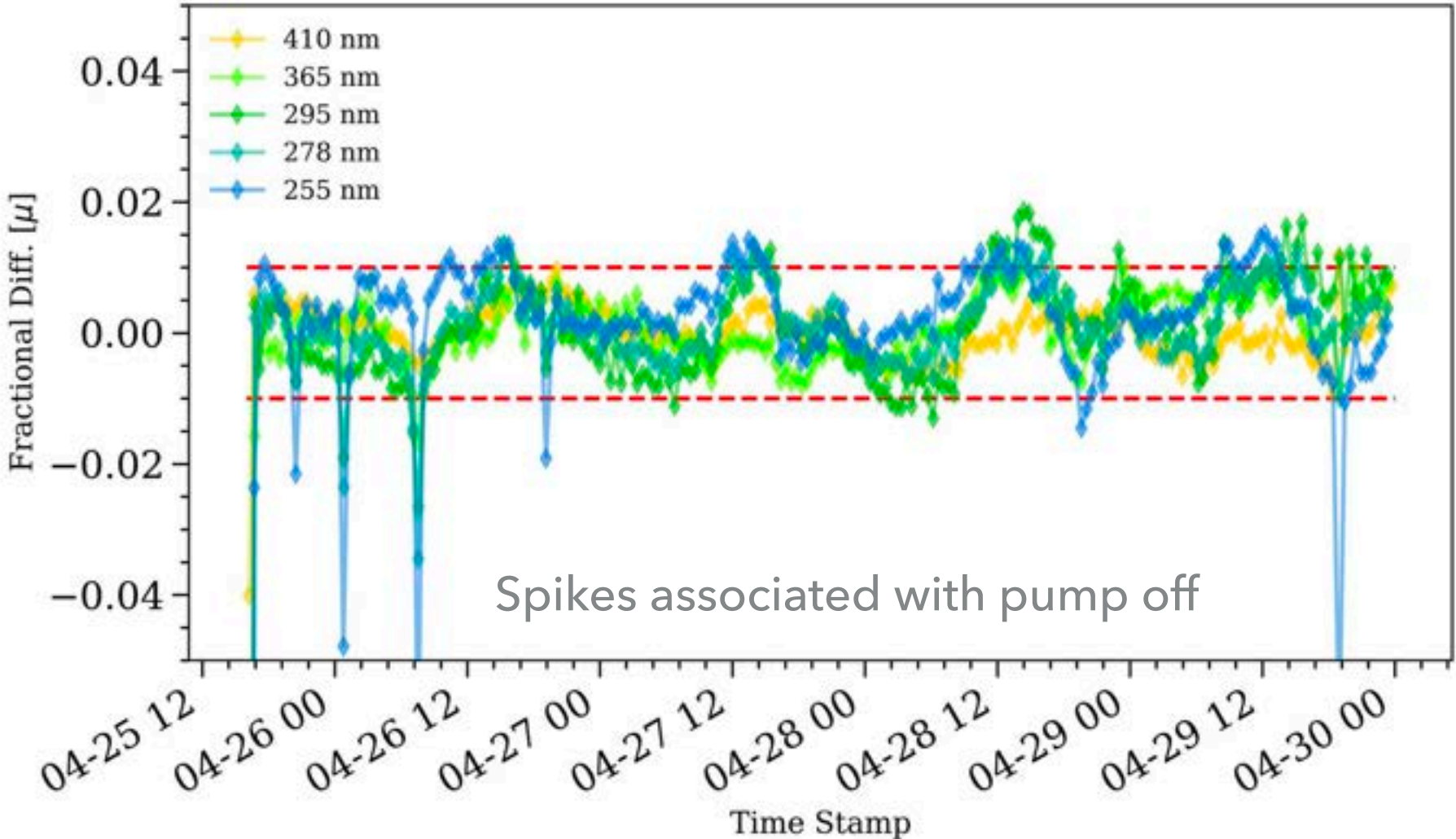

# WCTE PHYSICS OBJECTIVES

- ▶ Test particle identification and reconstruction algorithms in a small water Cherenkov detector
  - ▶  $e/\gamma$  separation possible with ML-based algorithms
  - ▶ ML-based algorithms (particularly sensitive to data/MC differences) directly tested on data
  - ▶ Energy reconstruction and energy scale error
- ▶ Constrain neutrino interaction cross section on oxygen through the measurement of lepton scattering
  - ▶ Multi-nucleon interactions
- ▶ Measurement of pion, proton, kaon interactions in water
  - ▶ Pion final state interaction and secondary interaction crucial for modelling neutrino interactions
- ▶ Measurement of neutron multiplicity from hadrons
  - ▶ Particle identification and  $\nu-\bar{\nu}$  separation
- ▶ Measurement of  ${}^9\text{Li}$  production rate from  $\pi^-$ 
  - ▶ Background in DSNB search

# NEUTRON MULTIPLICITY

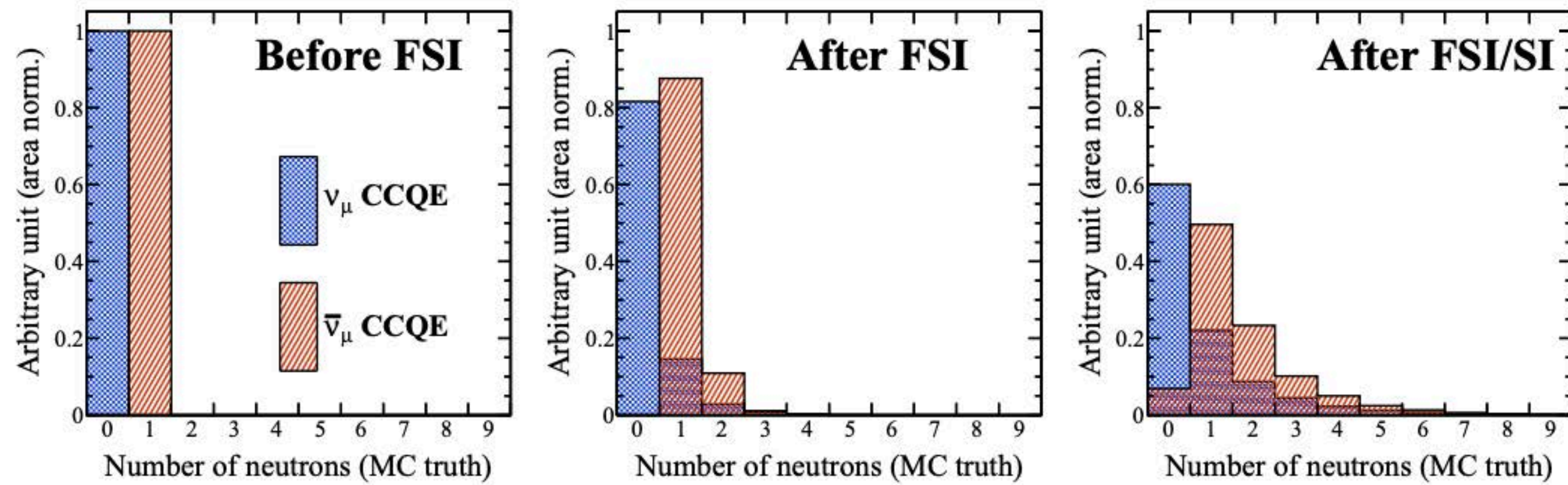

- ▶ Number of neutrons in the final state can help separate  $\nu$  and  $\bar{\nu}$  interactions
- ▶ Study of neutron production from beam proton and pion
  - ▶ Look for proton candidates within  $\sim 150 \mu\text{s}$  after primary beam particle
  - ▶ Neutron capture on 0.03% Gd with  $\sim 75\%$  efficiency and  $\sim 65 \mu\text{s}$  lifetime

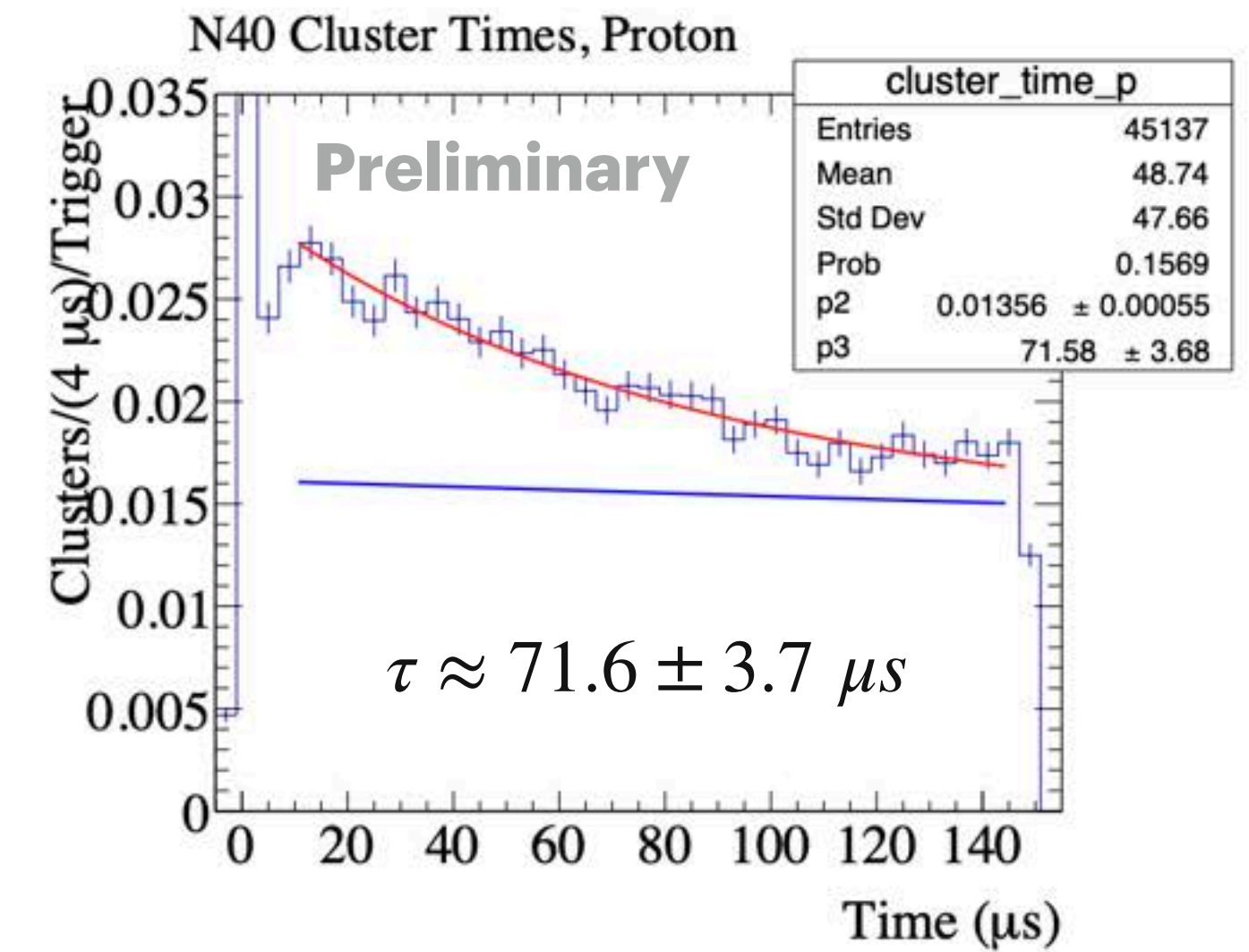

Neutron capture time in 0.03% Gd measured using protons in beam

Control sample: decay electron

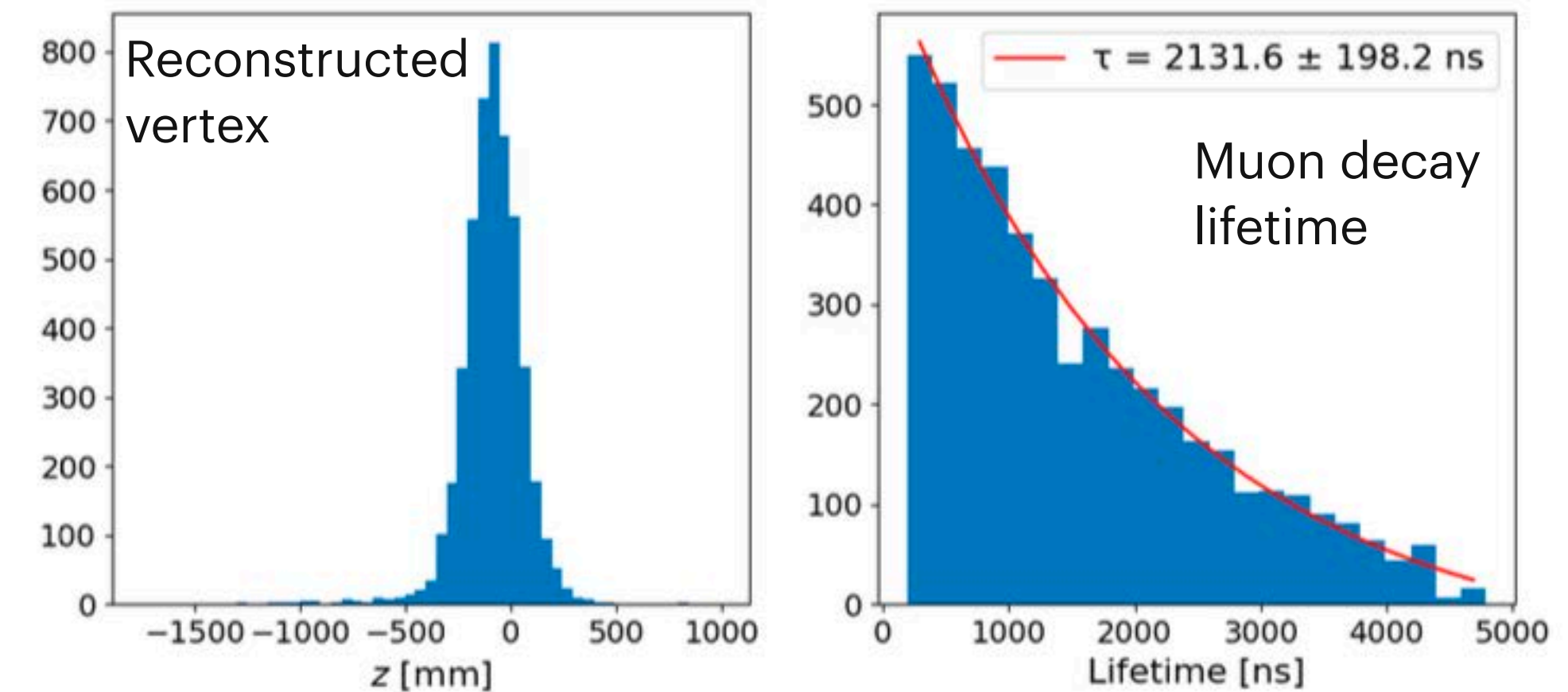

# <sup>9</sup>Li PRODUCTION FROM $\pi^-$

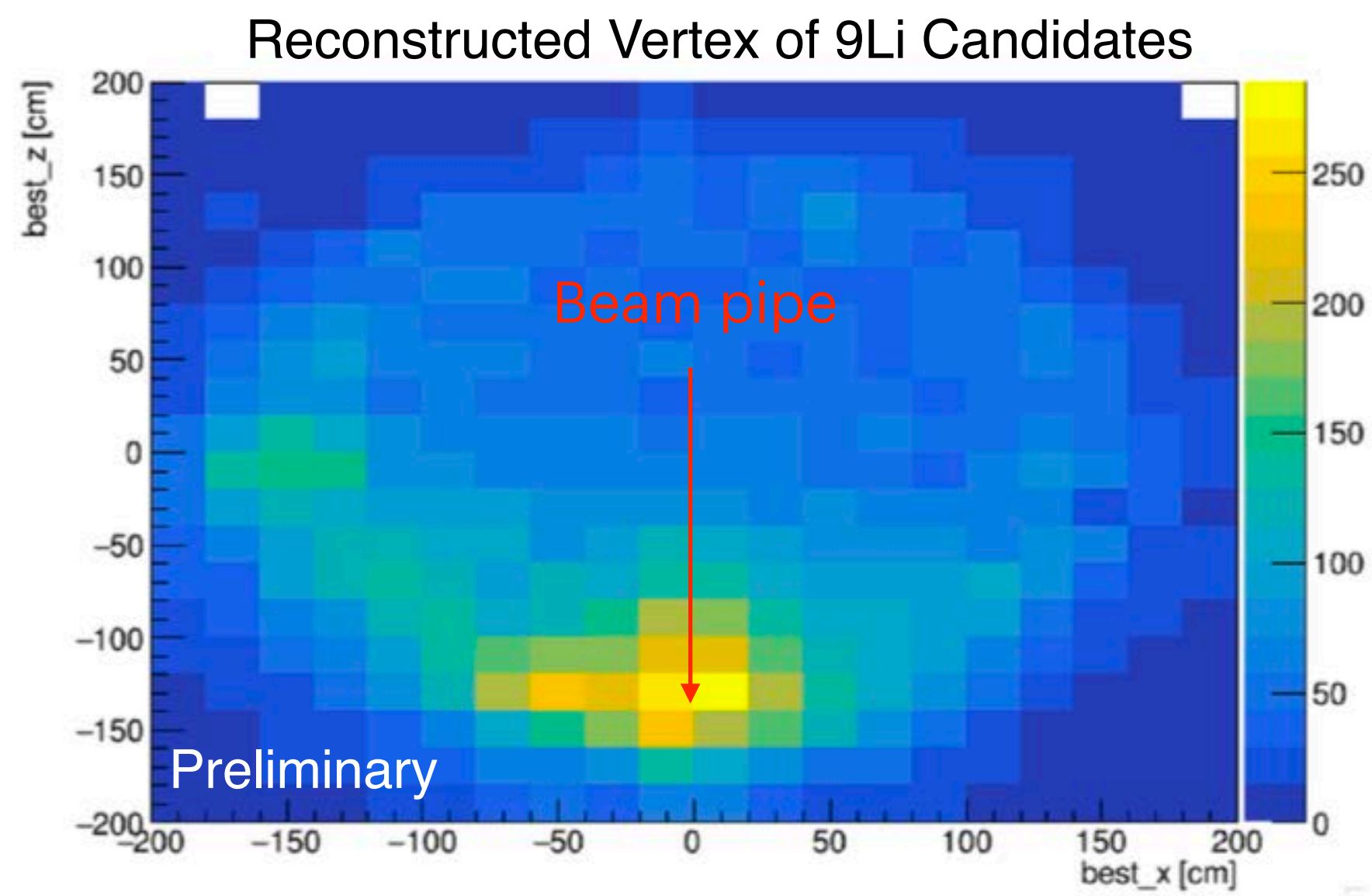
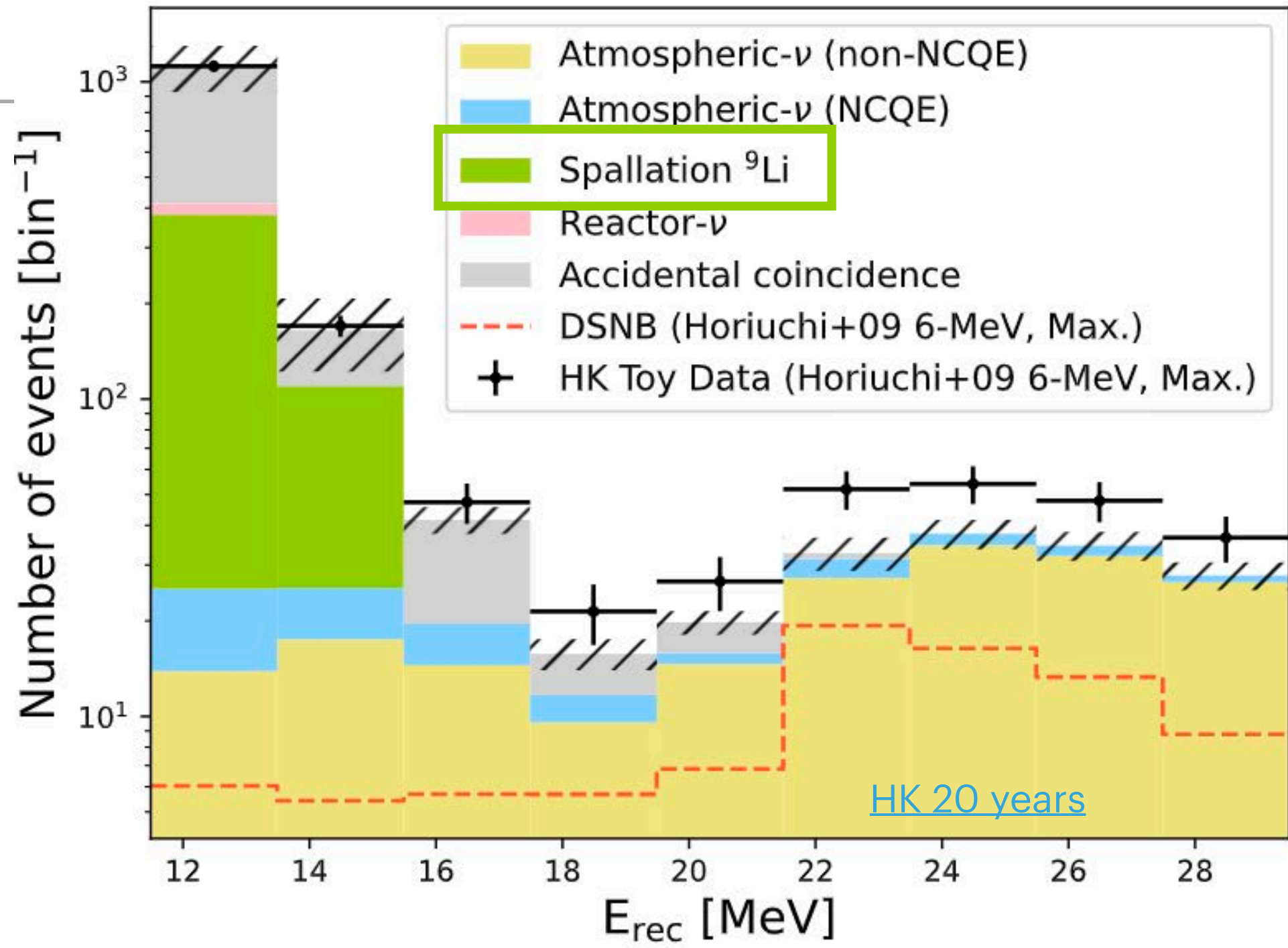
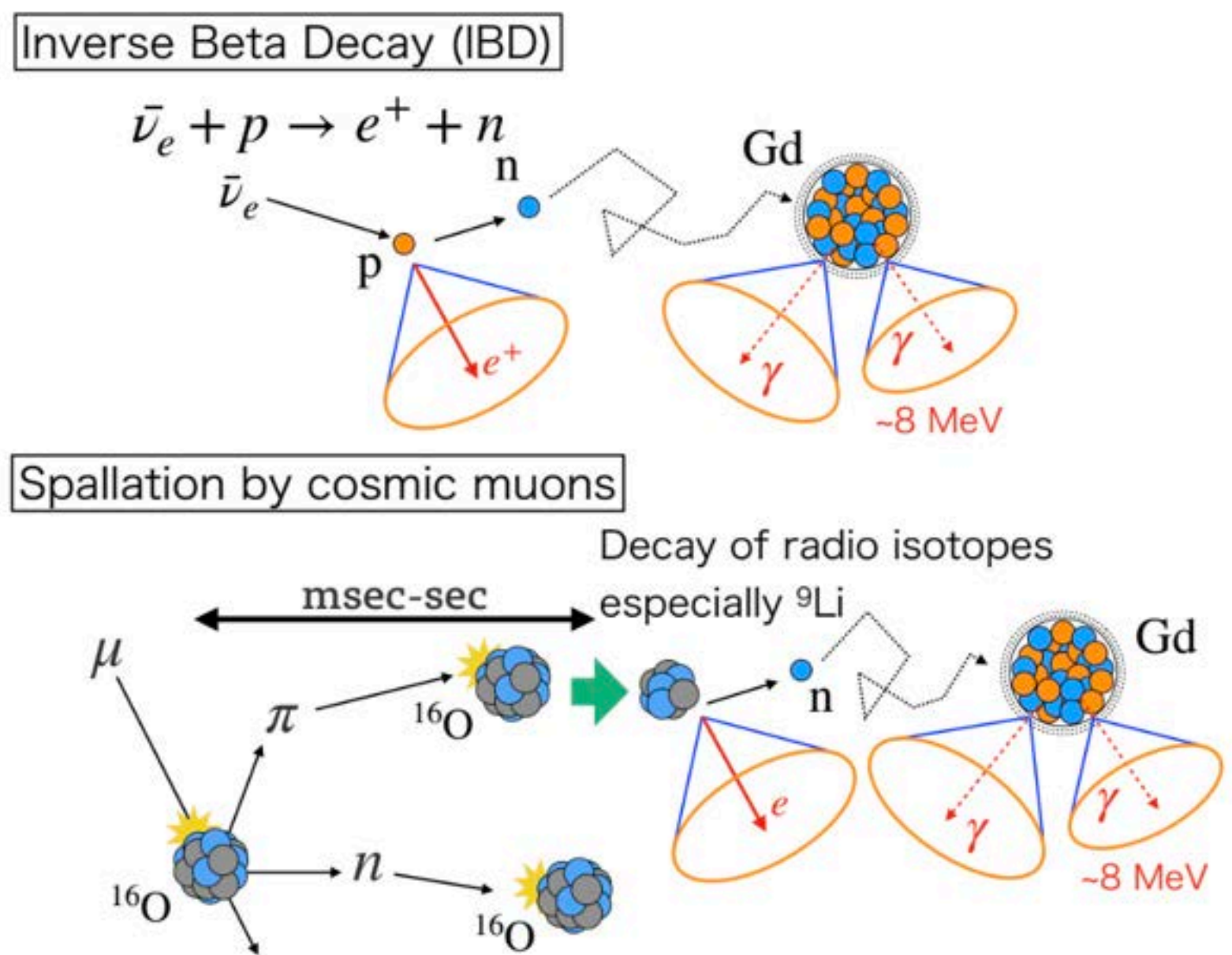
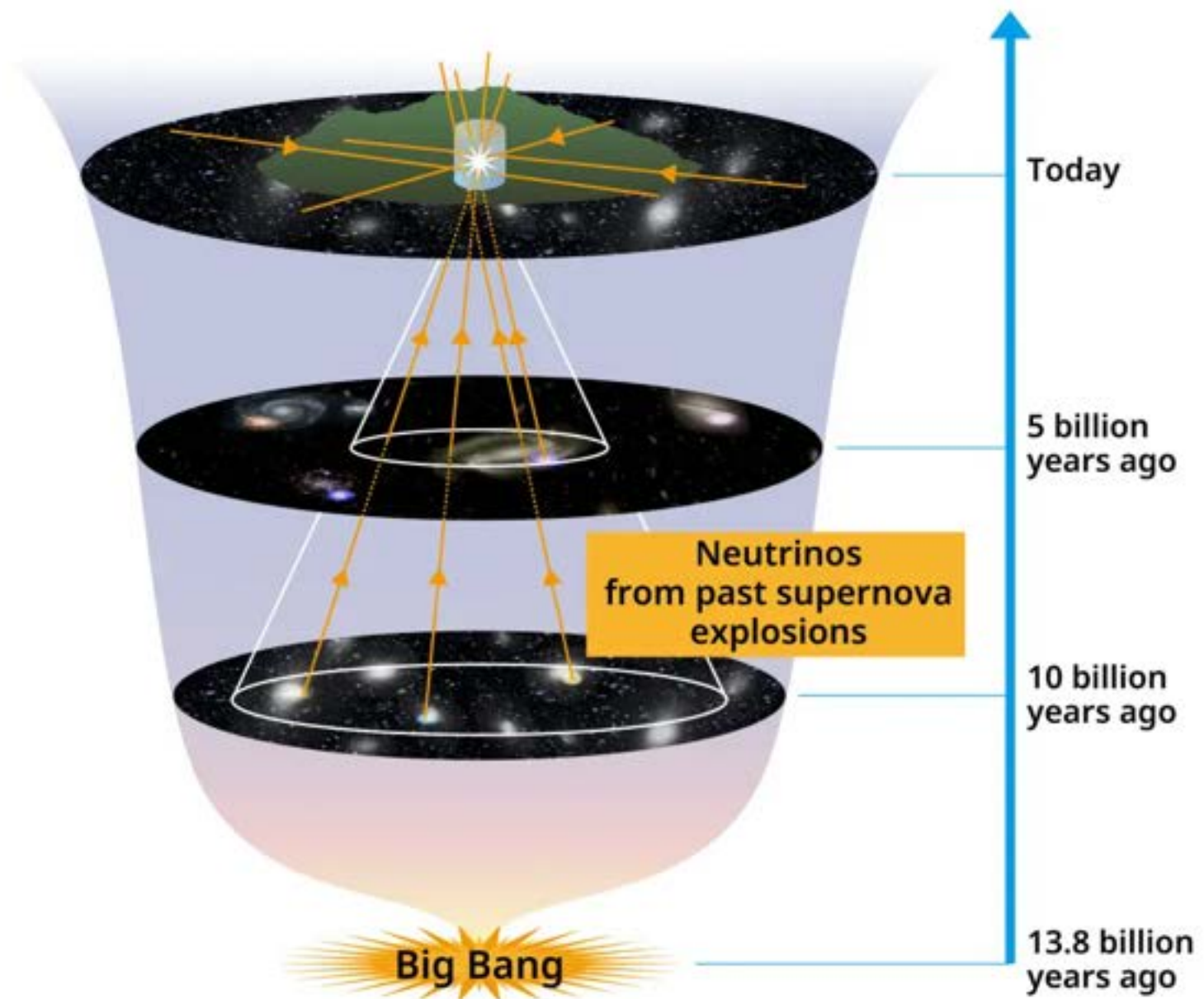

- ▶ Cosmogenic <sup>9</sup>Li forms an irreducible background in the search for diffuse supernova neutrino background (DSNB)
- ▶ We can search for <sup>9</sup>Li in a 0.5 s window after the beam → directly measure <sup>9</sup>Li production rate from  $\pi^-$

# CLOSING REMARKS

- ▶ Hyper-Kamkiokande will be a prolific experiment with a broad physics program, including the potential discovery of leptonic CP violation
  - ▶ Intermediate Water Cherenkov Detector (IWCD) plays a crucial role
  - ▶ Systematic uncertainties need to be reduced
- ▶ WCTE has been a successful technology prototype of IWCD, which allowed us to test out all important aspects of IWCD
  - ▶ Hardware, readout and DAQ, detector calibration, software tools, ...
- ▶ WCTE data analysis is ongoing, the results of which will benefit existing and future water Cherenkov experiments
- ▶ Hyper-K Canada group is making important contributions to the project. **Join us!**

## Hyper-K Canada Collaborating Institutes



University  
of Windsor



University  
of Victoria



THE UNIVERSITY OF  
WINNIPEG



BRITISH COLUMBIA  
INSTITUTE OF TECHNOLOGY



Carleton  
UNIVERSITY



University  
of Regina

# THANK YOU FOR YOUR ATTENTION



WCTE Analysis Workshop, Kavli IPMU, U. Tokyo, Feb. 2026

# WCTE IN T9

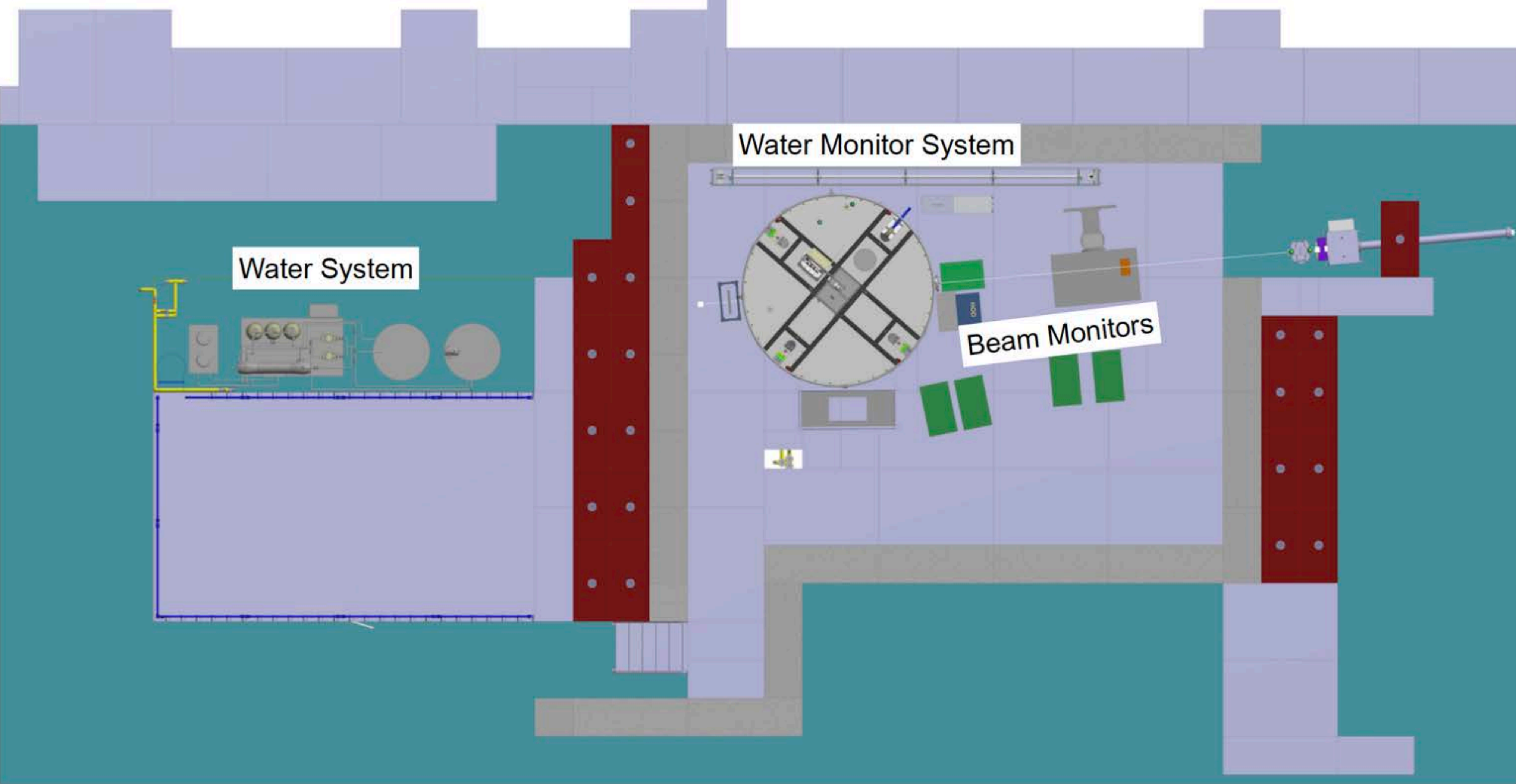

# PHYSICS DATA

Data Type	Water Type	Beam Configuration	Beam Momenta (MeV/c)	Trigger mode	Statistics	Detector condition
<b>Pion scatter, particle identification, energy scale, 9Li</b>	Pure water	Charged particle (+, -)	200 - 500 (33 points)	Self trigger	20k muons, 10k at most momenta	Normal
<b>Muon Scattering</b>	Pure water	Charged particle (+, -)	780 - 800	Self trigger, hardware trigger	~550k in total	Normal
<b>Electron Scattering</b>	Pure water	Charged particle (+, -)	600 - 950	Hardware trigger	~10 M at each momentum	Bubbles on mPMTs
<b>Gamma Particle Identification</b>	Pure water	Tagged photon	500, 650, 800, 1000	Self trigger	100k gammas at each momentum	Normal
<b>High energy proton reconstruction</b>	Pure water	Charged particle (+)	1100 - 1500	Hardware trigger	100k protons at each momentum	Normal
<b>Minimum bias data</b>	Pure water	Charged particle (+)	80 - 500	Self trigger, hardware trigger	100k positrons	Majority normal, some affected by bubbles on mPMTs
<b>Kaon Reconstruction</b>	Pure water, Gd water	Charged particle (+, -)	1100 - 1150	Hardware trigger	A few thousand K+/-	Bubbles on mPMTs
<b>9Li and 2p-2h in <math>\pi</math> quasi-elastic scattering</b>	Gd water	Charged particle (+, -)	260 - 360	Self trigger	~5k pions and 10-20k muons at each momentum	Bubbles on mPMTs
<b>Secondary neutron production from proton</b>	Gd water	Charged particle (+)	1200, 1000, 800, 600	Self trigger	~100k protons at each momentum	Bubbles on mPMTs
<b>Lepton Scattering</b>	Gd water	Charged particle (+)	1200, 1000, 800	Self trigger	100k to 200k electrons each	Bubbles on mPMTs
<b>Photonuclear interaction</b>	Gd water	Tagged photon	1000, 800, 650, 500	Self trigger	500k events at each momentum	Bubbles on mPMTs

# WCTE BEAM

CERN T09 particle flux - Negative polarity  
(2% momentum collimator setting)

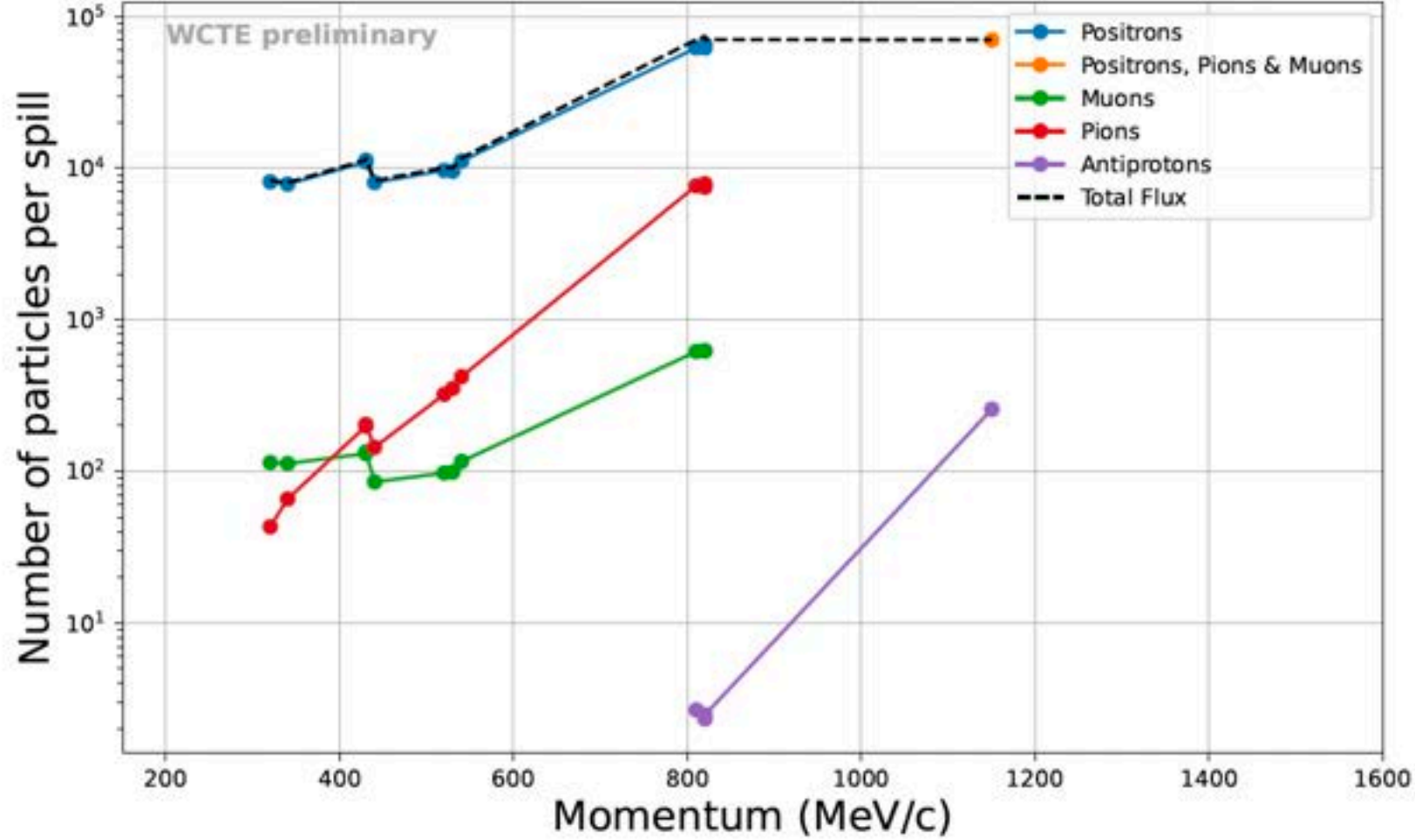

Run 2038 (440 MeV/c, negative polarity)

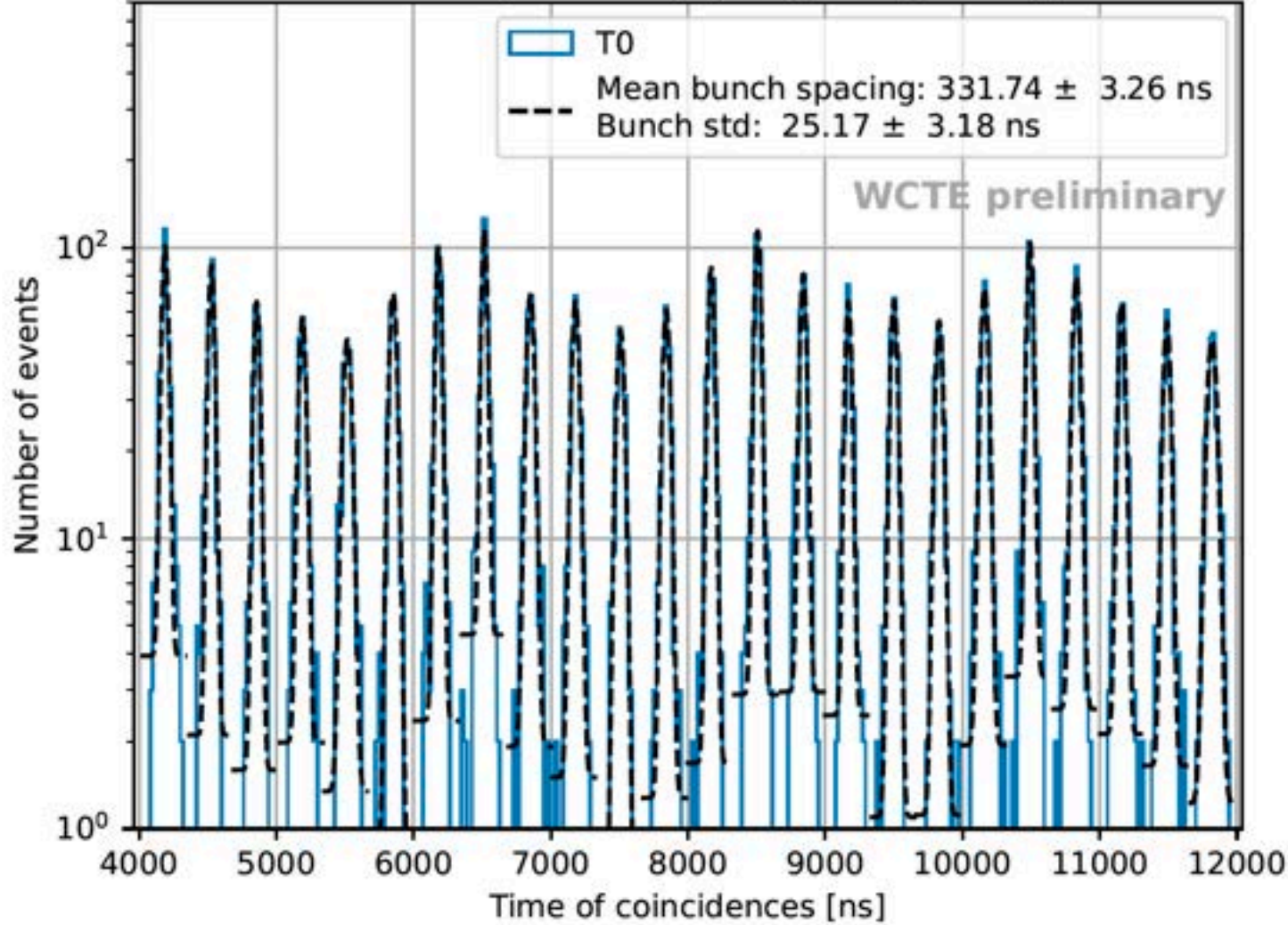

T9 beam temporal structure

CERN T09 beam momentum - Negative Polarity

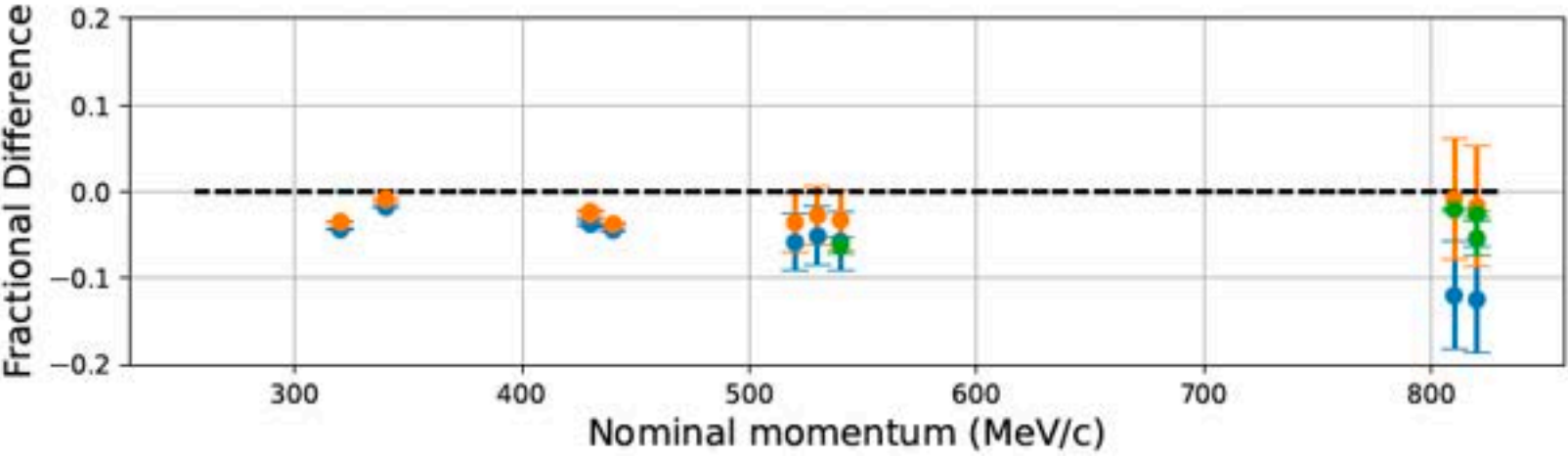
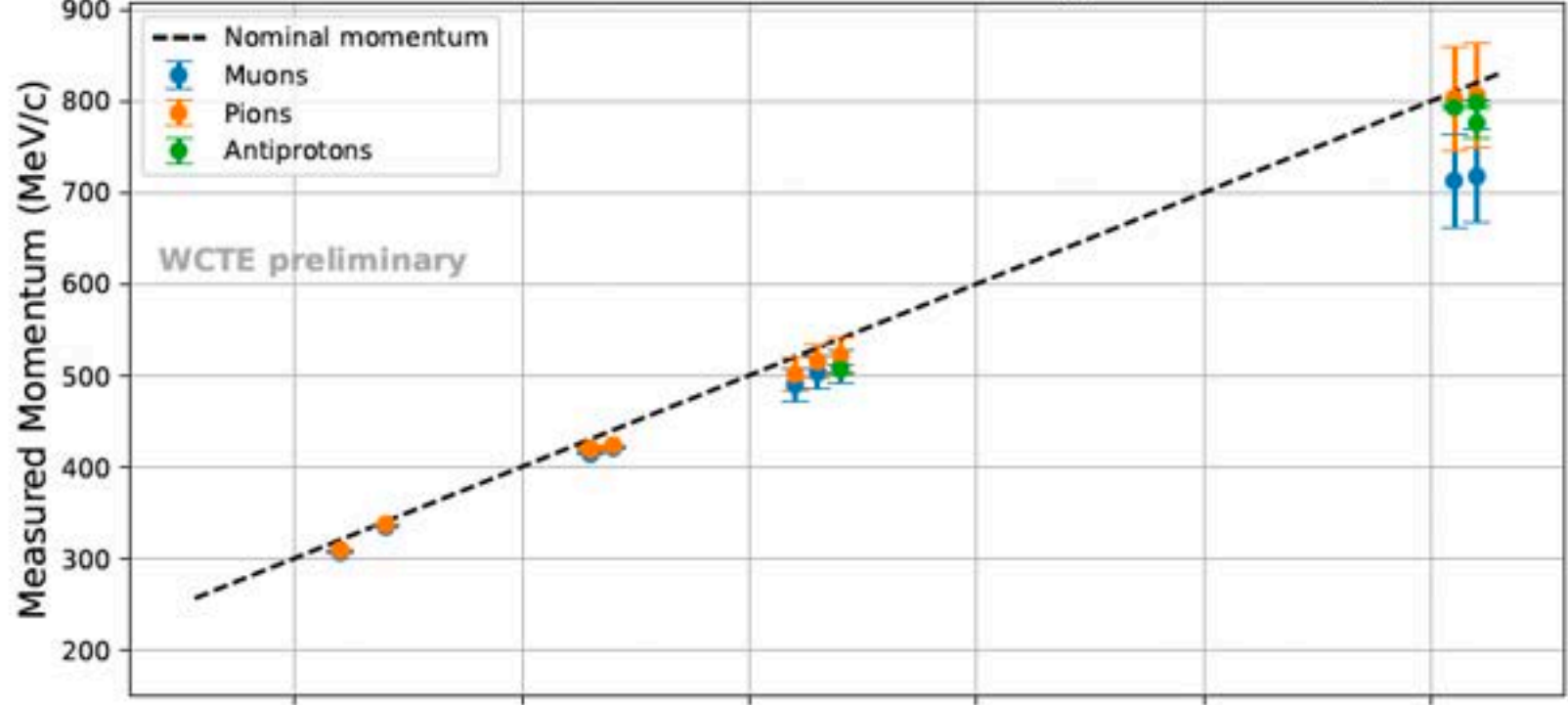

CERN T09 beam momentum - Positive Polarity

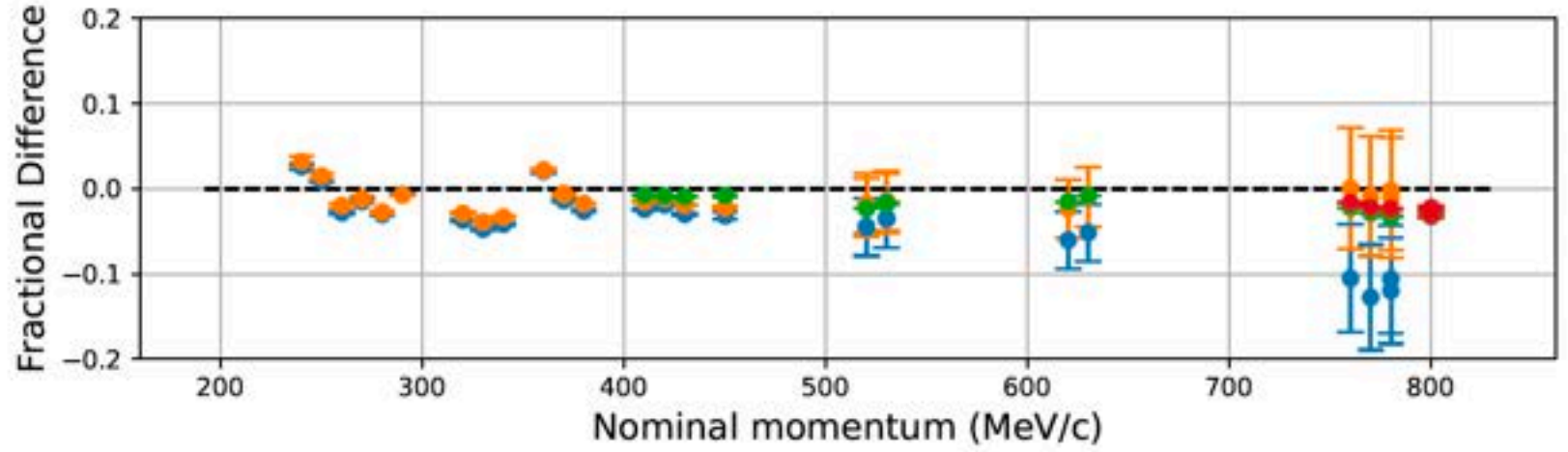
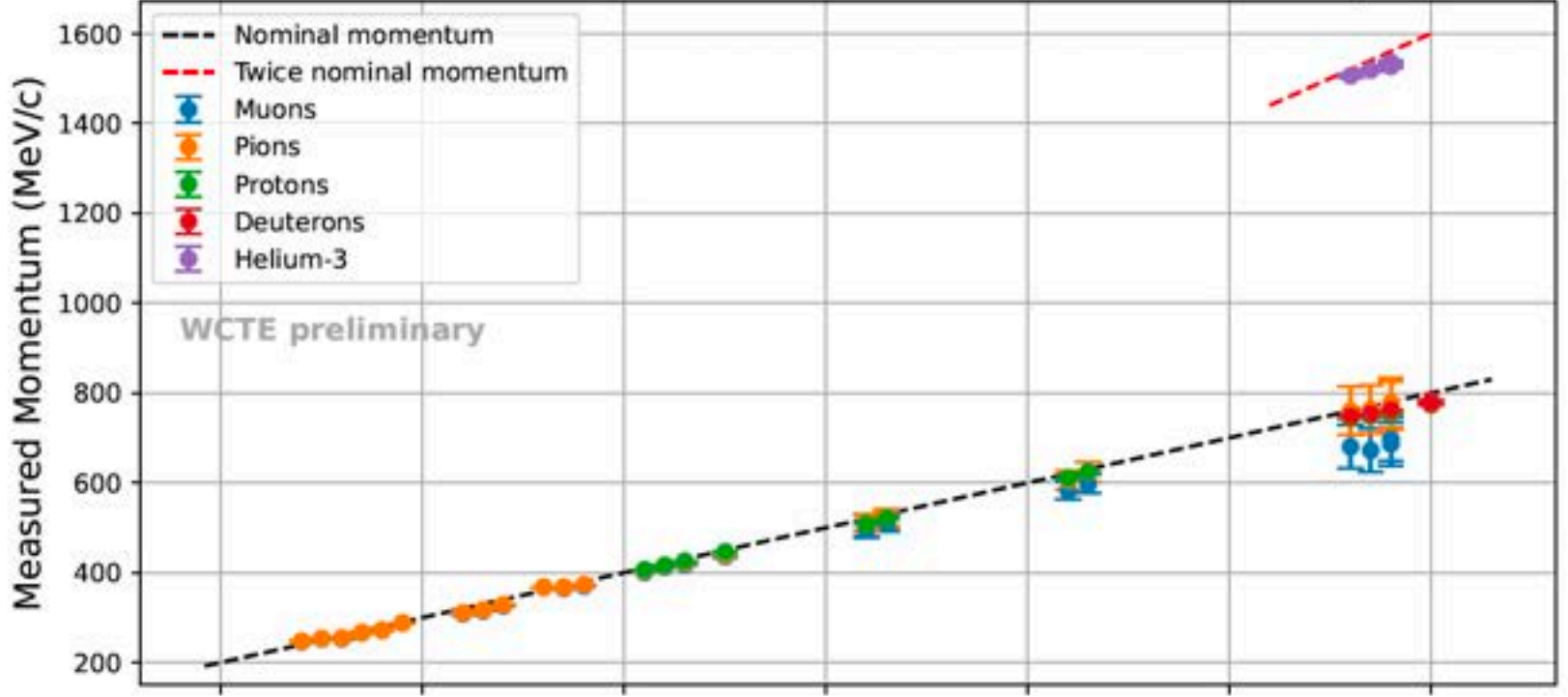

# GD LOADING

- ▶ Gd loading to 0.03% was achieved after four Gd injections on May 21-23
  - ▶ ~75% neutron capture on Gd, ~64  $\mu$ s neutron lifetime
  - ▶ Gd concentration increase is tracked using GAD
  - ▶ Short of the 0.2% target (>90% neutron capture efficiency) due to delay in the shipment of Gd removal resins
- ▶ Pressure test of the water system prior to obtaining authorization to start Gd loading on May 12 may have created air leak, which persisted for the rest of the 2025 run
- ▶ ~9 days of data taking with Gd

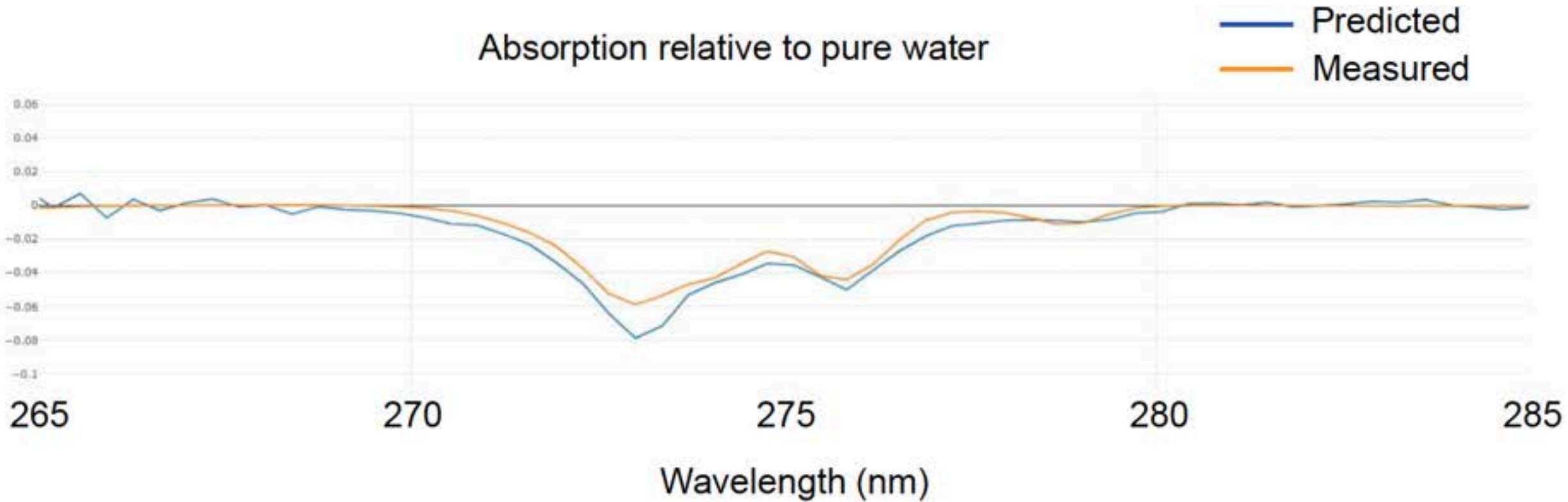

Gd is mixed using motorized mixer in Gd-mixing tank

# PHOTOGRAMMETRY

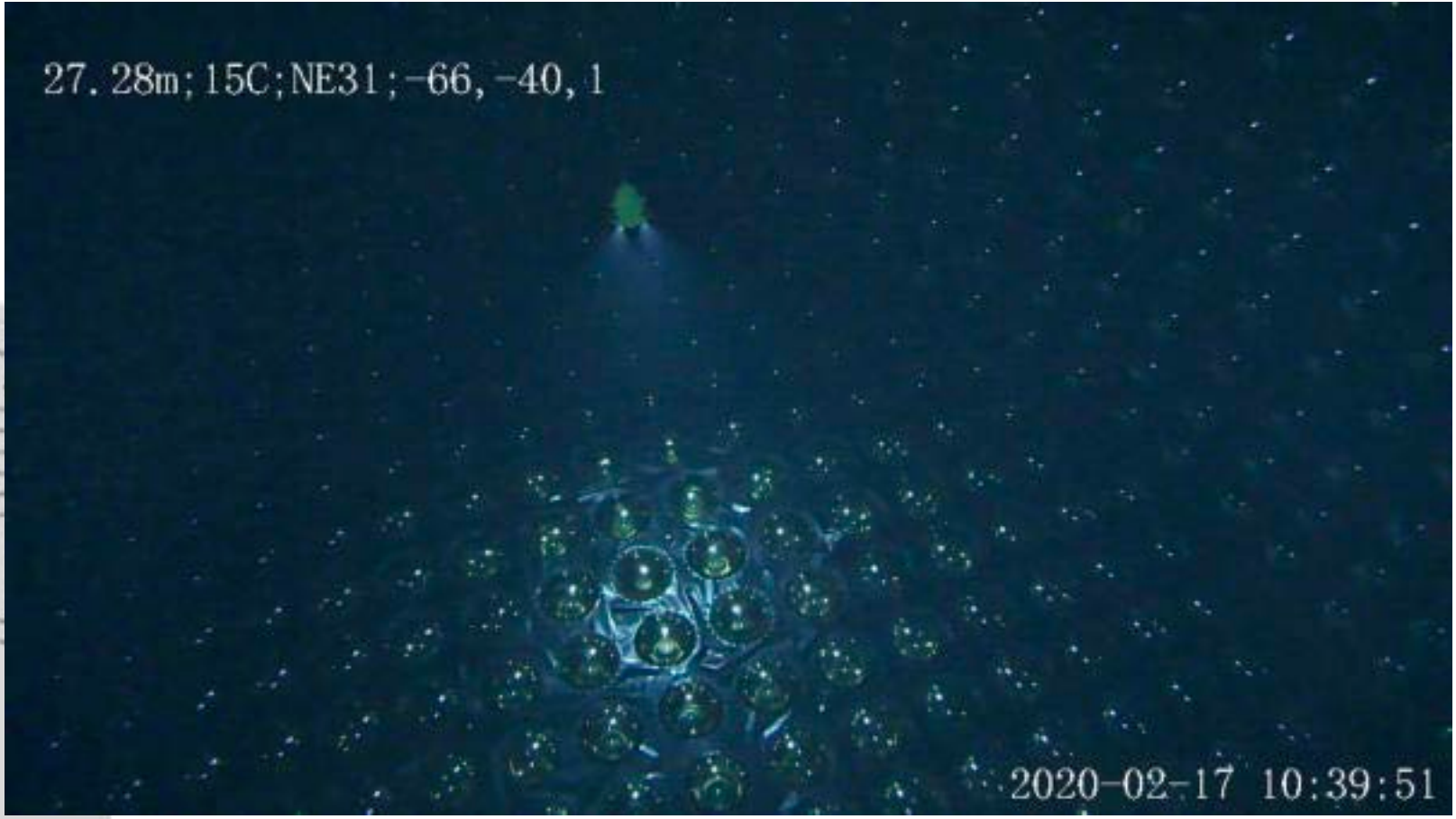
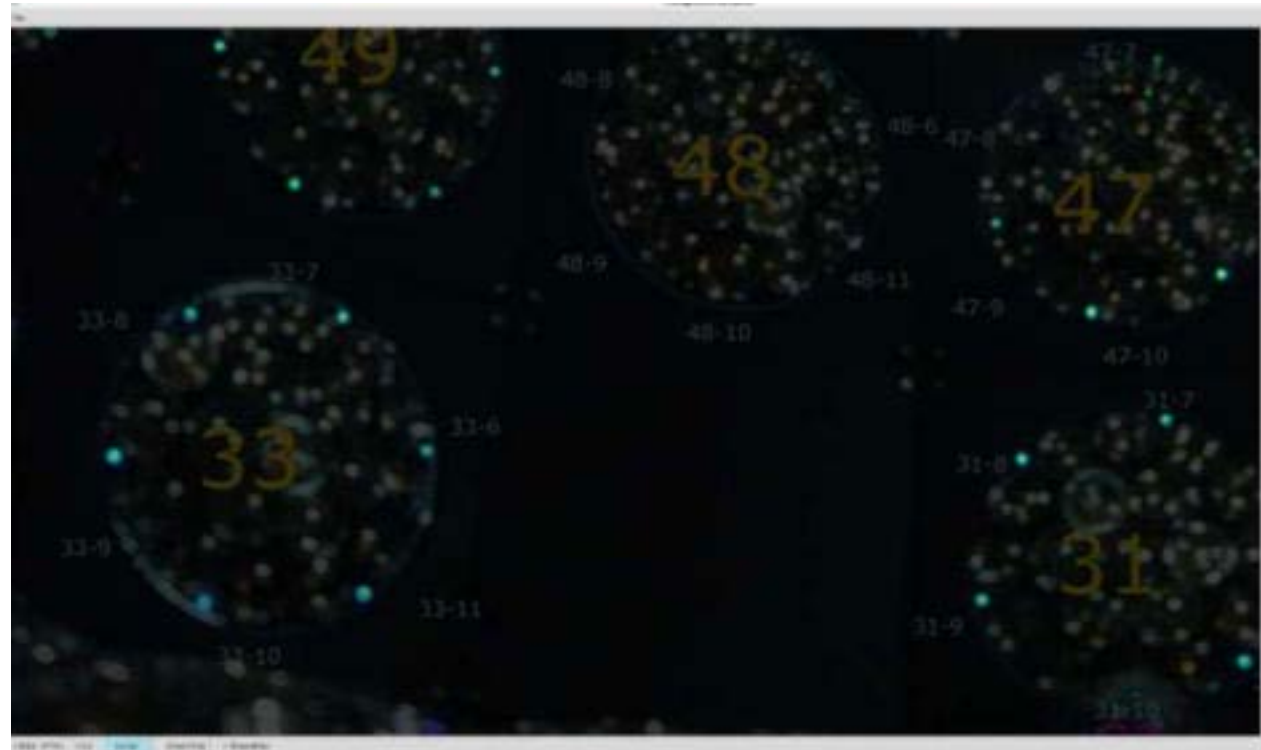
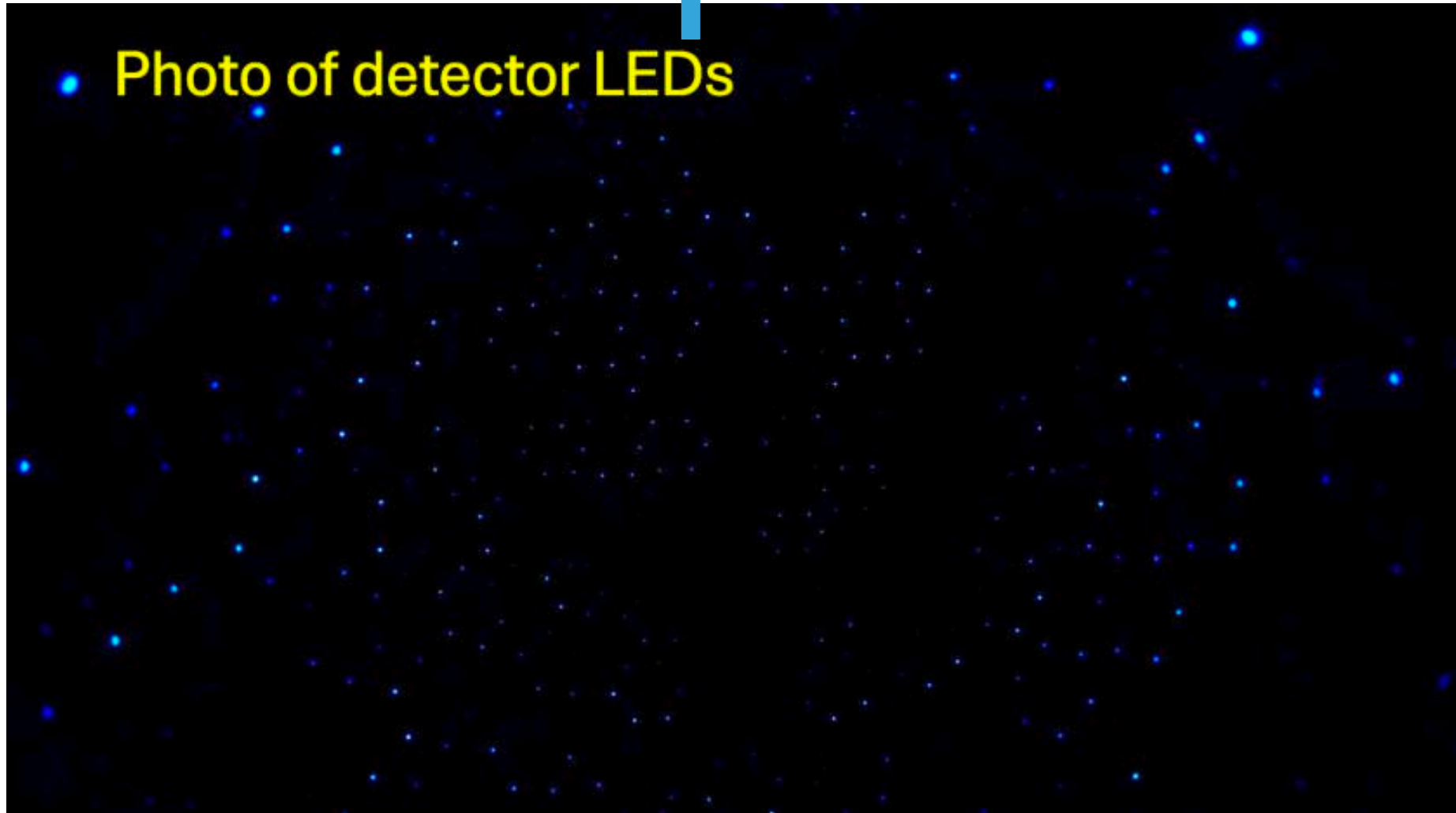
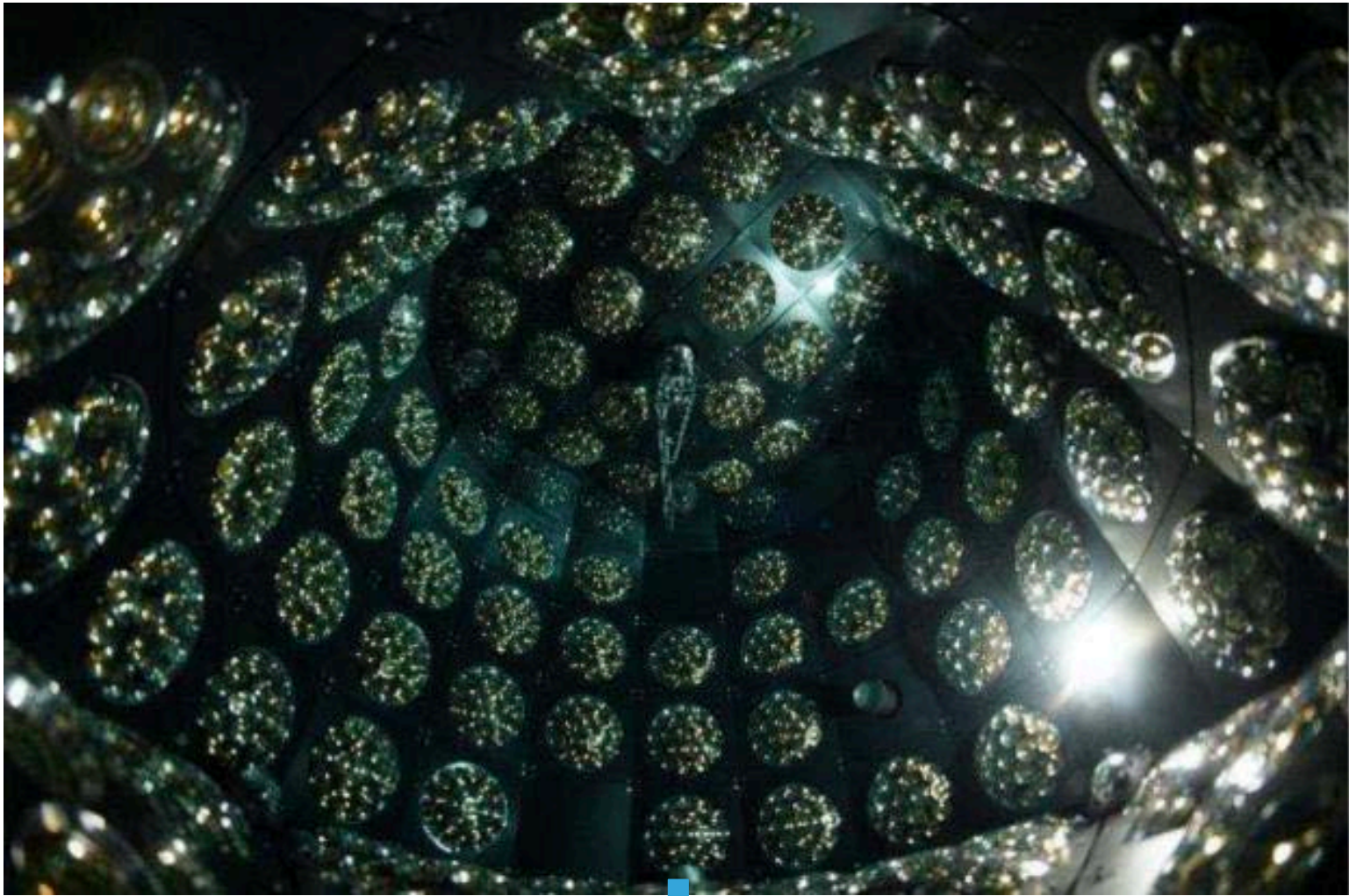

Super-K detector survey using ROV

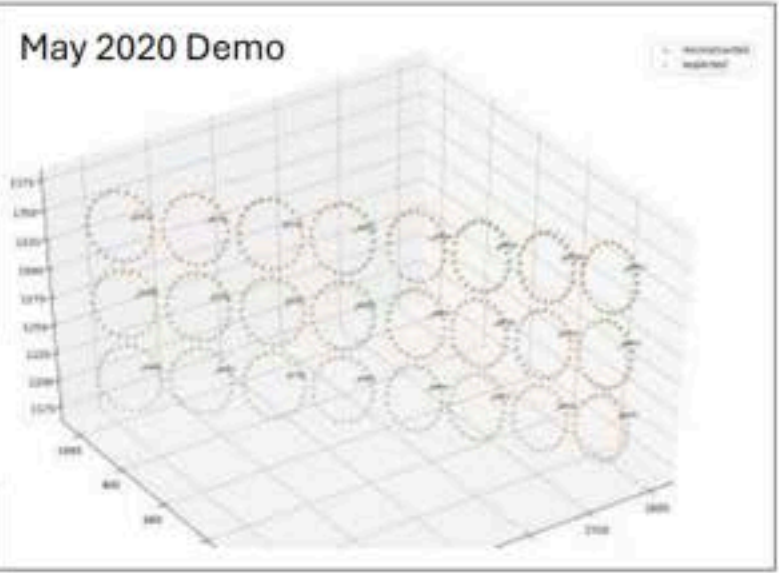
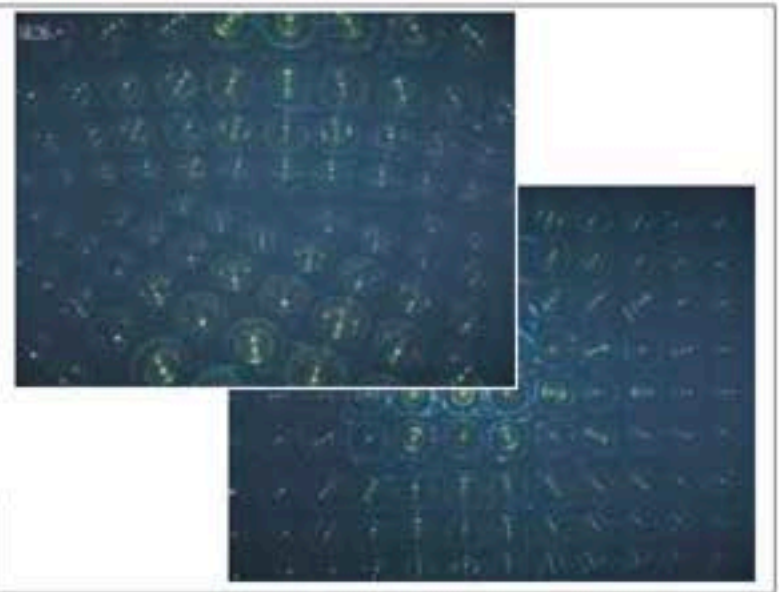
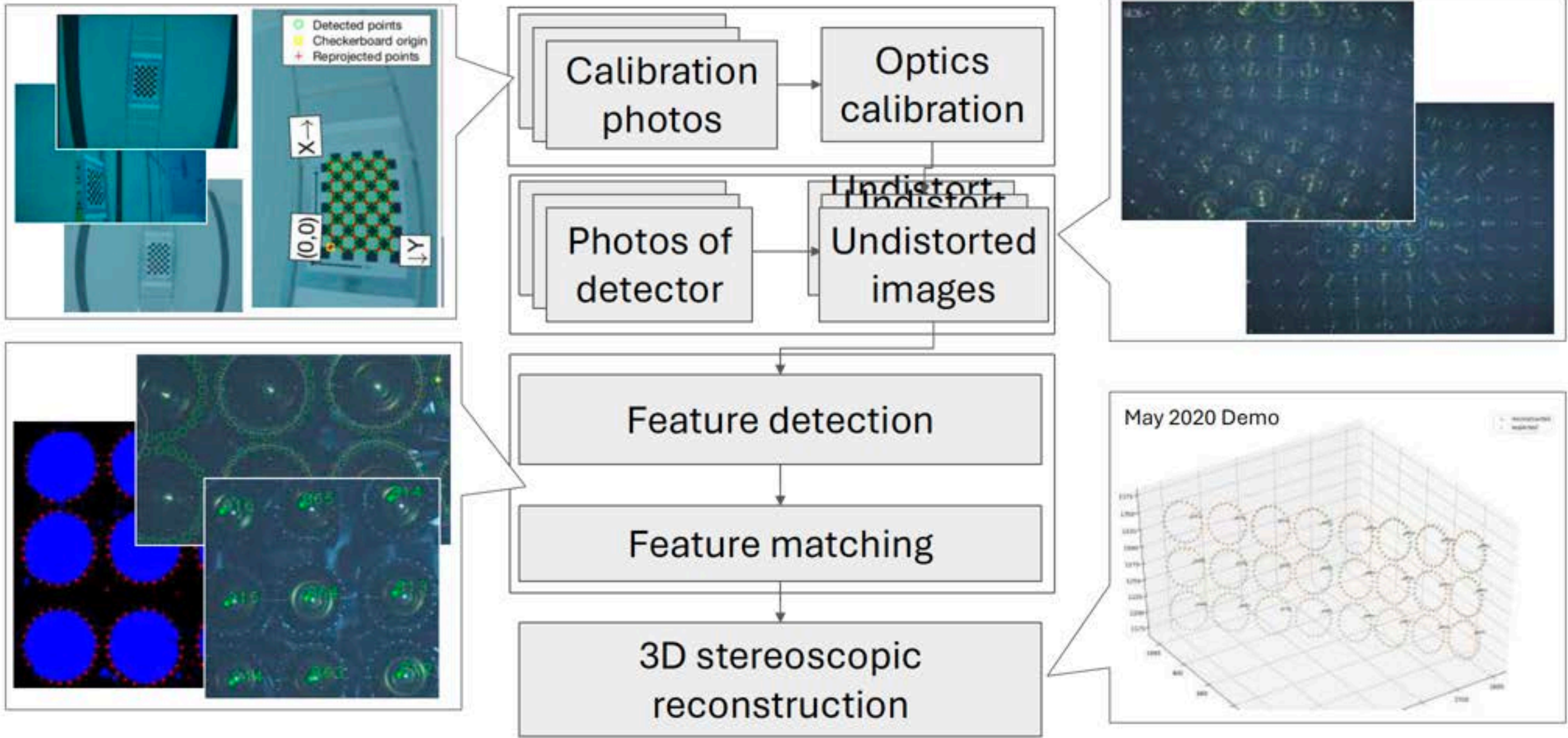

# WATER MONITORING SYSTEM

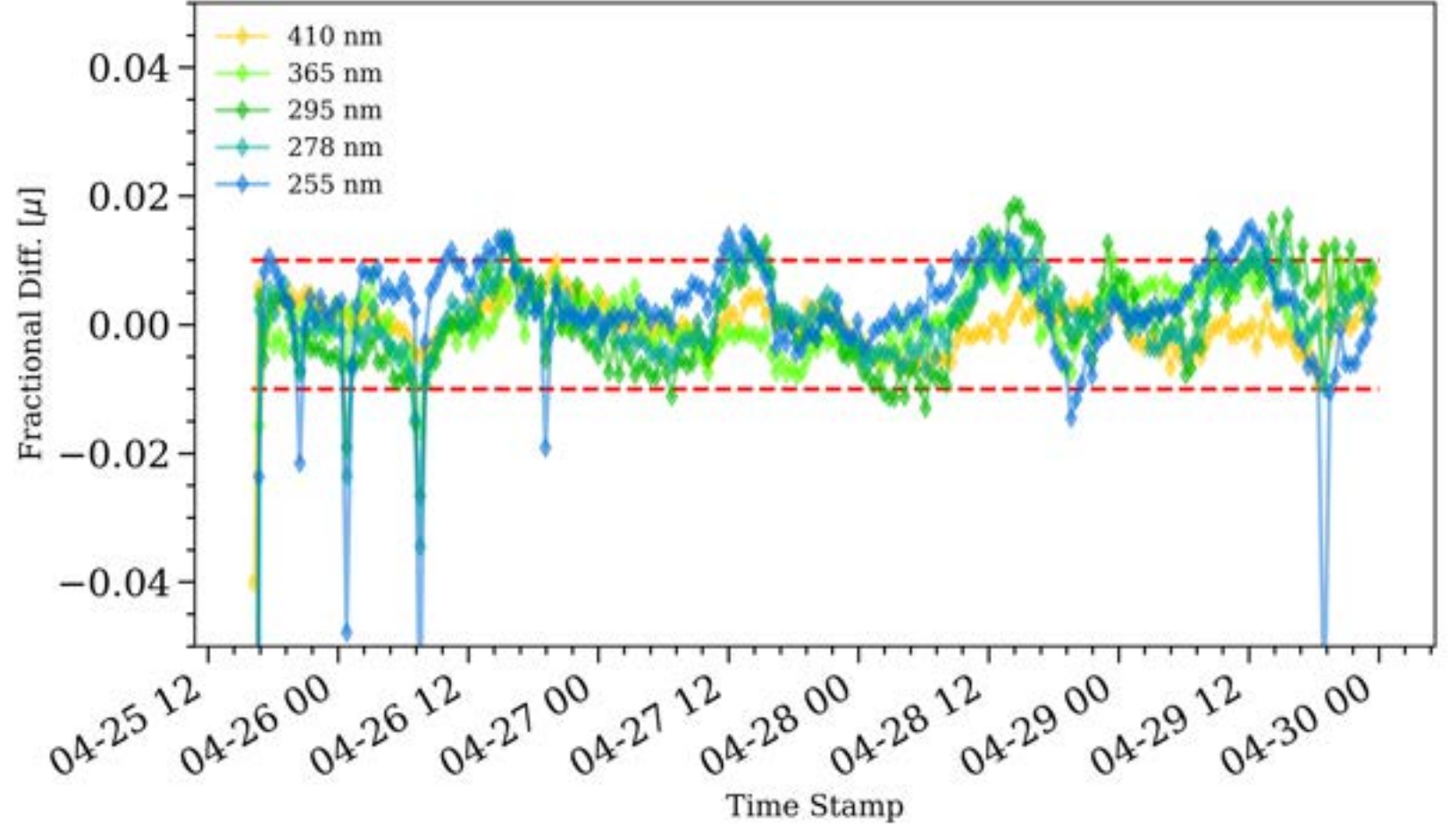
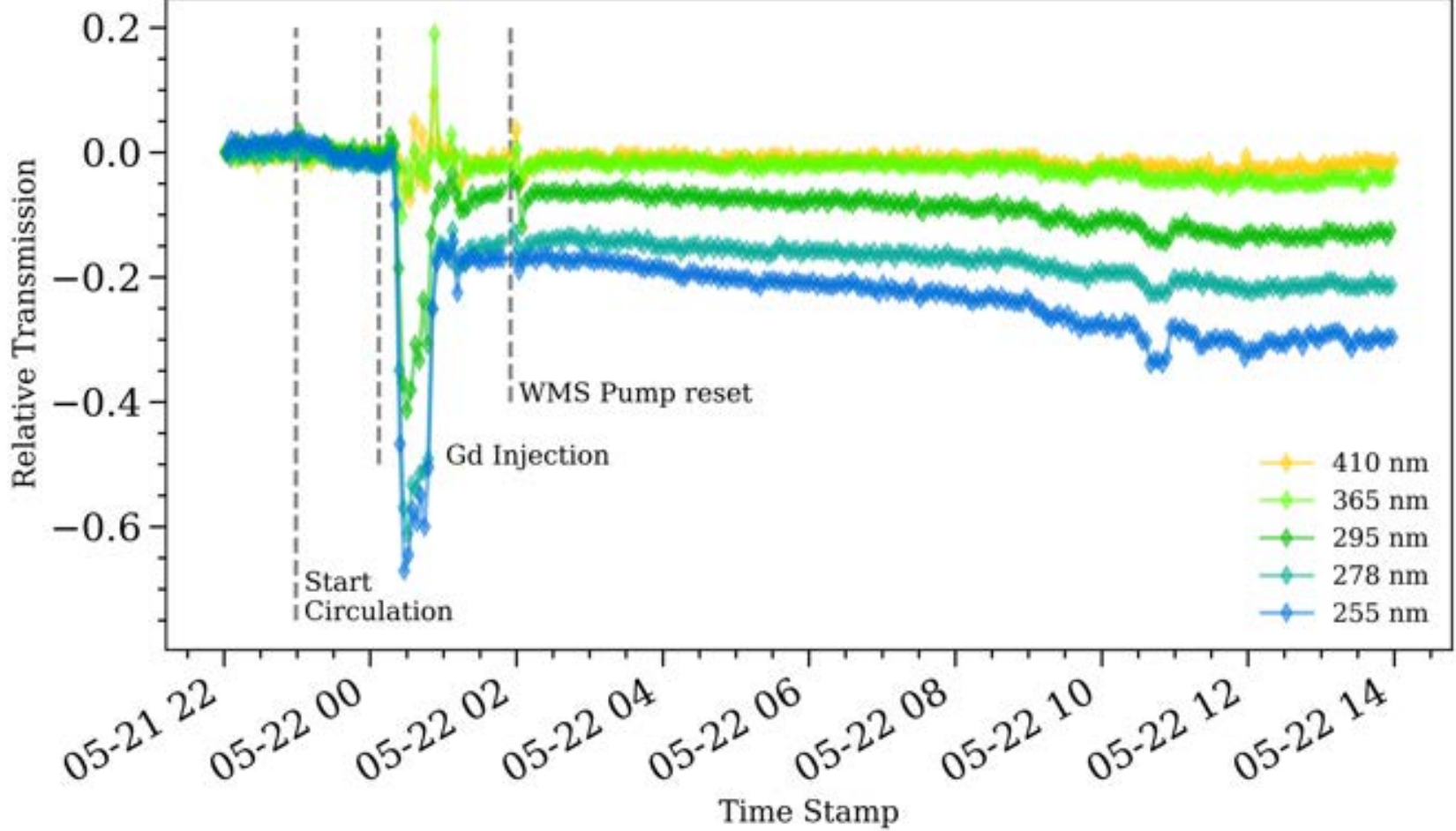
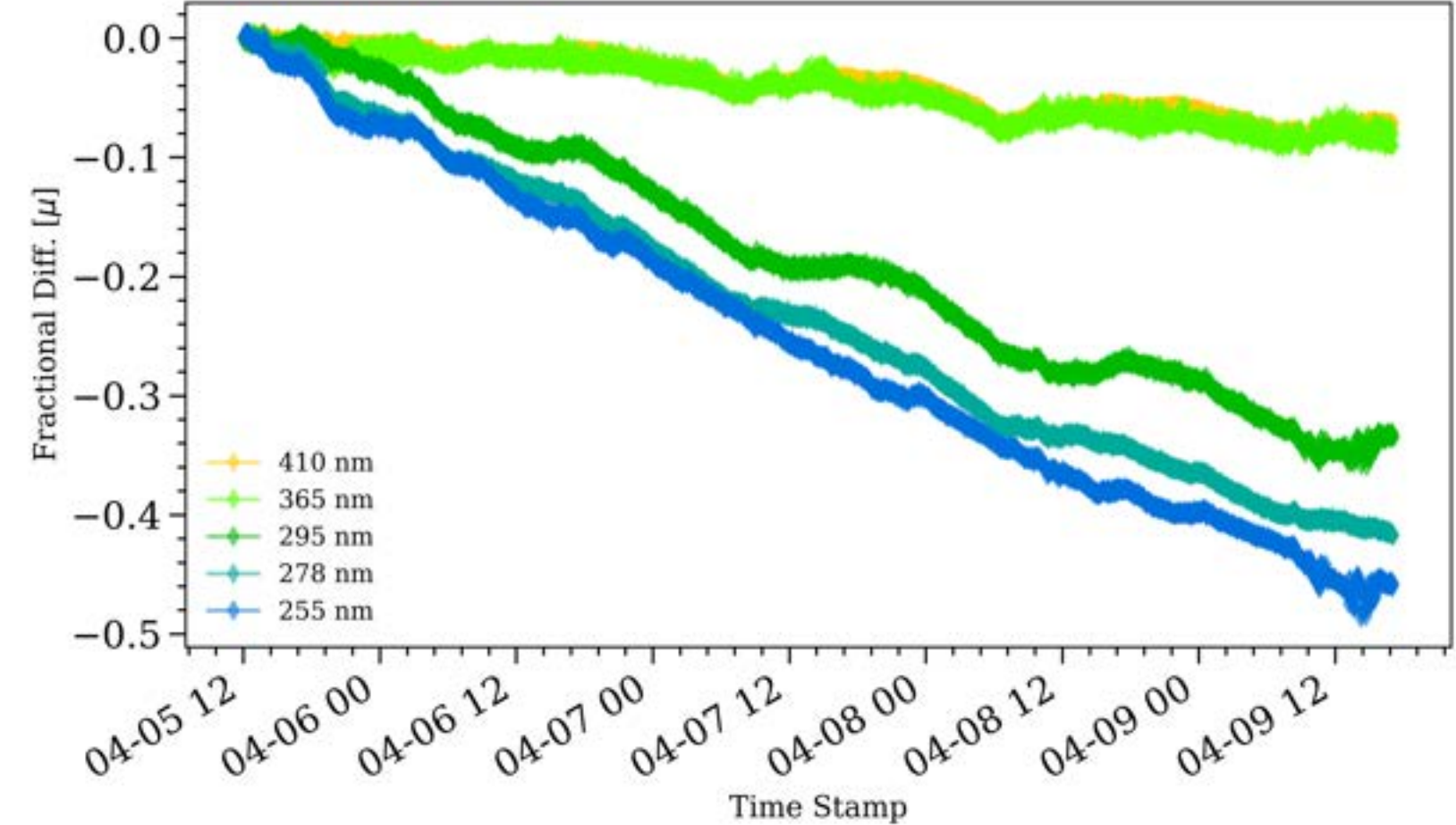

- Transparency dropped when water circulation was stopped and water was stagnant inside the chamber
  - Formaldehyde leaching from acrylic
  - 1% drop in transparency amounts to ~8 PPB

- WMS was used to track Gadolinium concentration in WCTE
  - 40ppm Gd [Gd<sub>2</sub>(SO<sub>4</sub>)<sub>3</sub>]
  - Increased absorption in UV
  - Gd gradually dissolved over a few hours

- WCTE detector water quality is stable
- Water transparency measured by the WMS is stable within 1%
  - Spikes are known periods where water circulation was paused

# DETECTOR CALIBRATION

- ▶ Individual PMT response
- ▶ PMT relative timing
- ▶ SPE gain, charge distribution
- ▶ Relative QE
- ▶ Charge nonlinearity
- ▶ Timing v.s. charge (TQ)
- ▶ Angular response
- ▶ Neutron tagging
- ▶ Detector geometry
- ▶ Reflectance from PMT and black sheet
- ▶ Light scattering and attenuation in water
- ▶ Absolute energy scale

LEDs in mPMTs  
Laser light injectors

Laser diffuser

Ni/Cf source

AmBe source

Photogrammetry

Ex-situ measurements

Test beam / cosmic muon

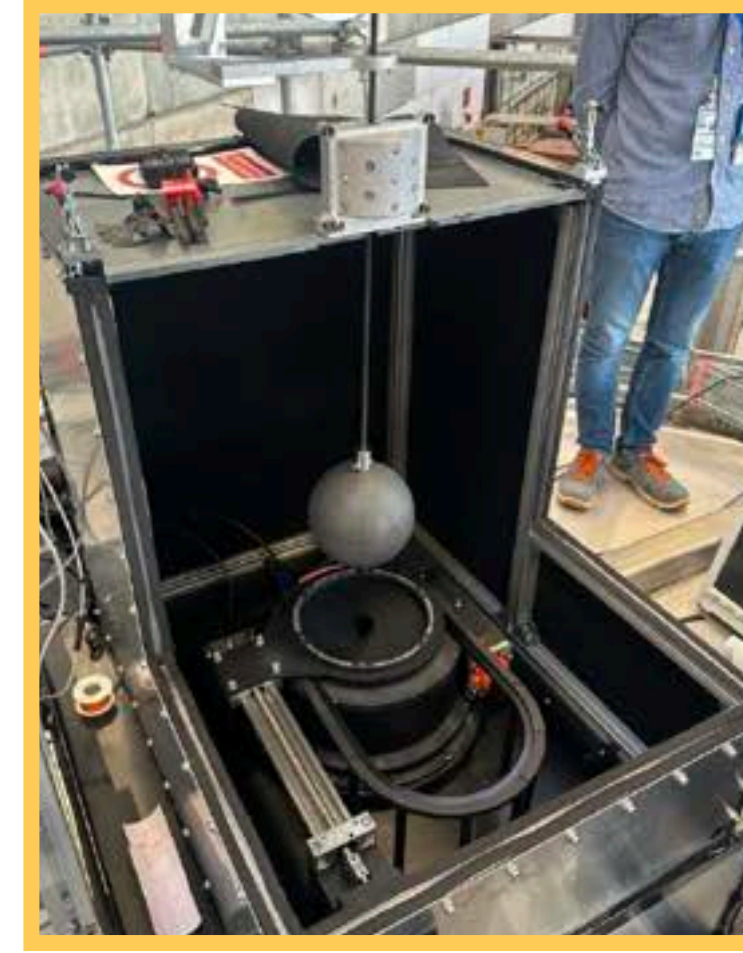

# WCTE PHYSICS GOALS (I)

- ▶ Study pion interactions in water
  - ▶ Absorption, charge exchange, quasi-elastic scattering
- ▶ Study  $e/\mu/\pi$  PID in a water Cherenkov detector

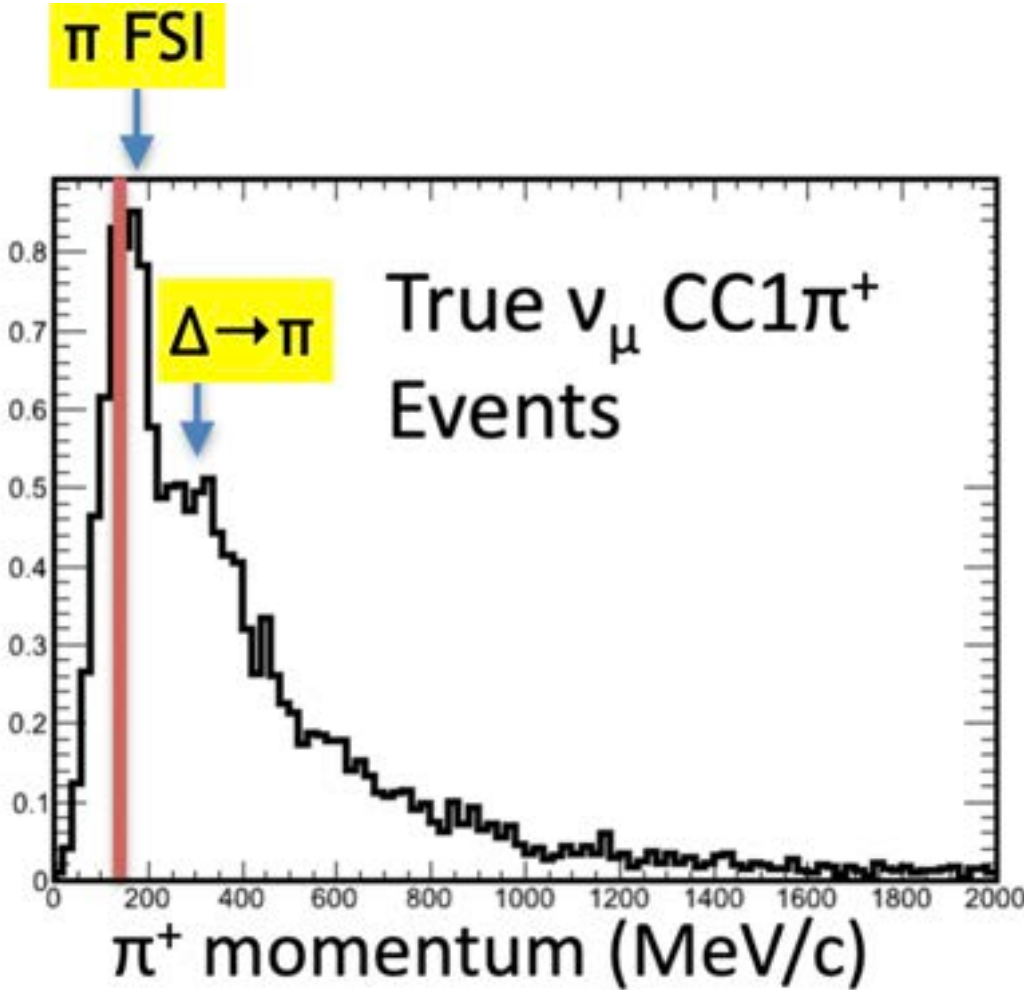

~500 MeV/c pions produced by neutrino interactions

WCTE

IWCD

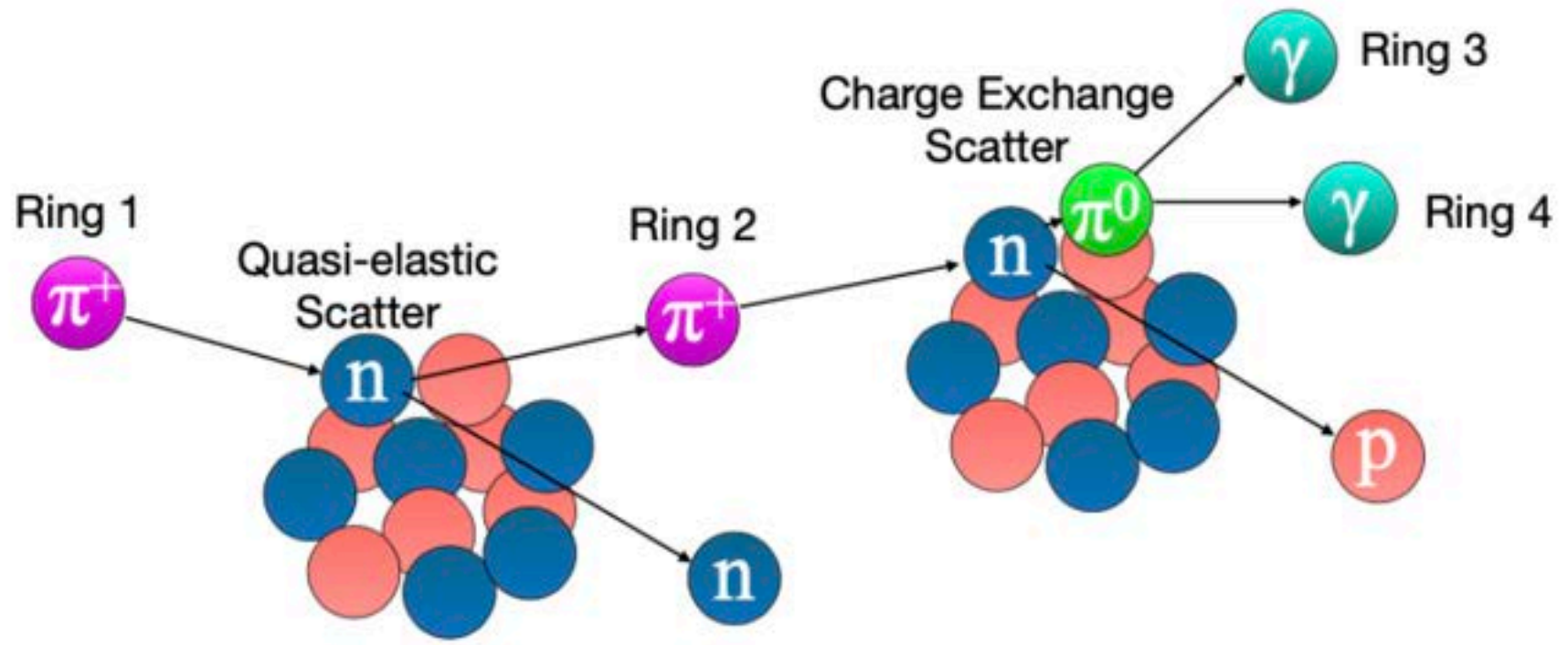
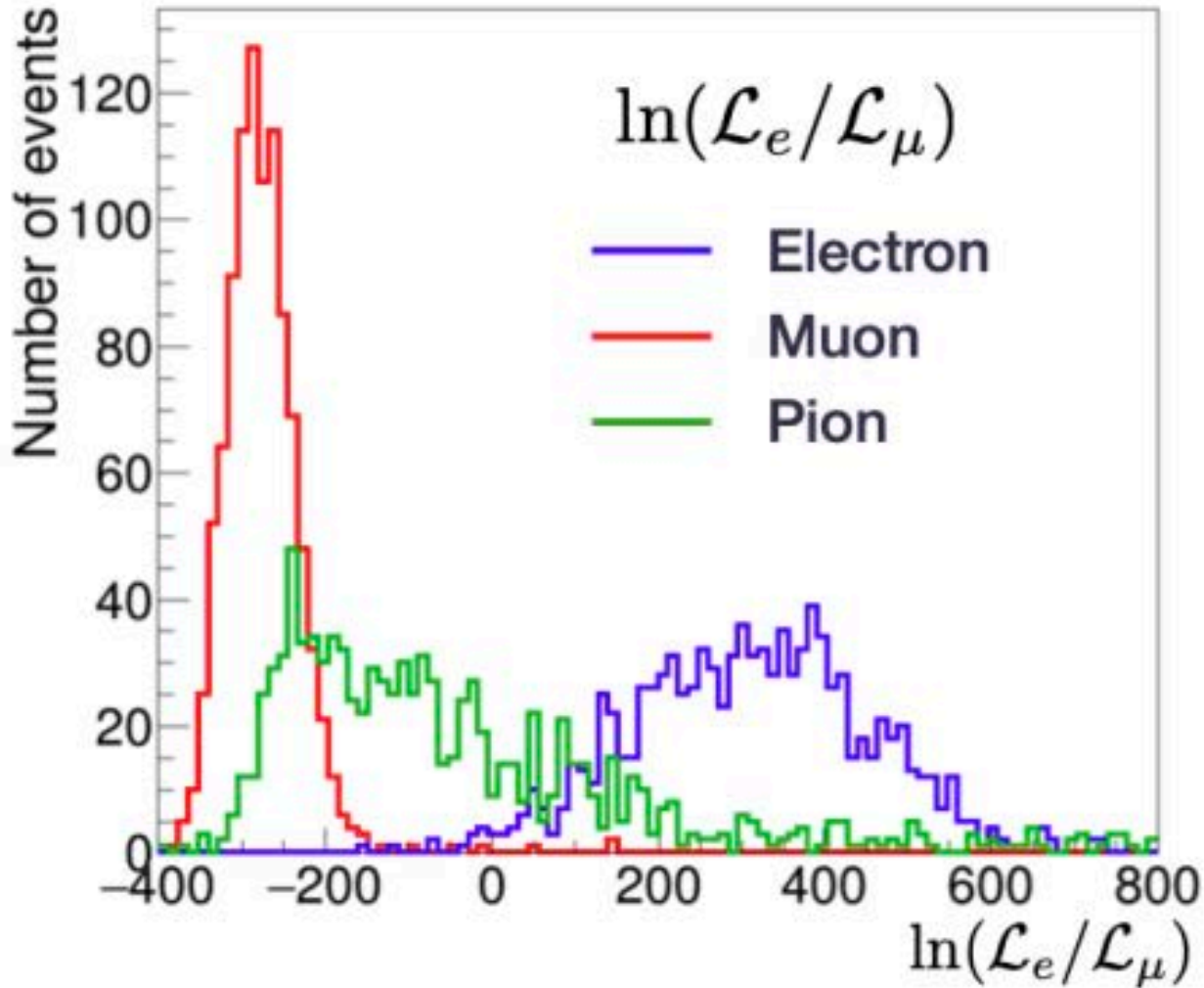
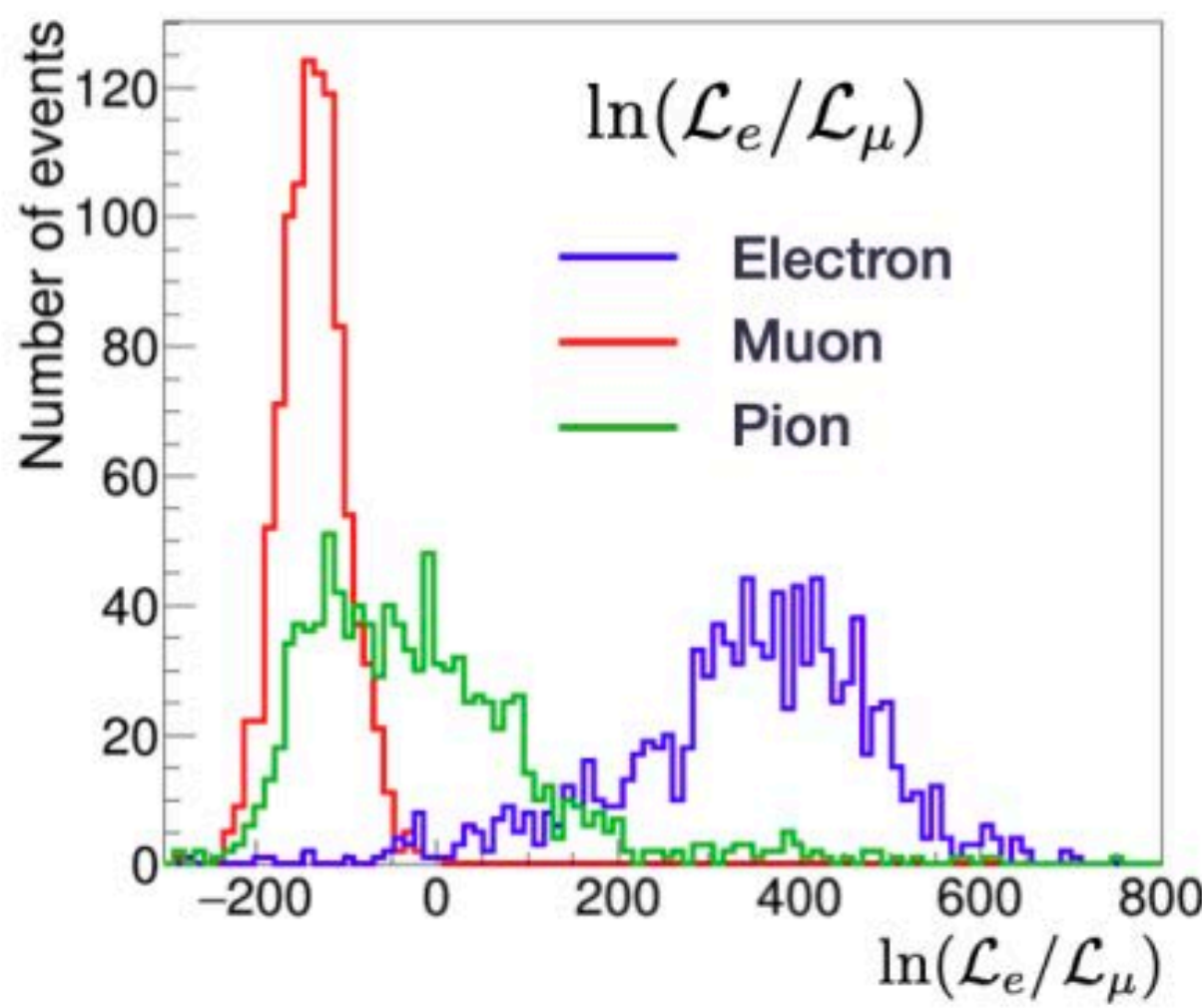

# WCTE PHYSICS GOALS (2)

- ▶ Study pion interactions in water
  - ▶ Absorption, charge exchange, quasi-elastic scattering
- ▶ Study  $e/\mu/\pi$  PID in a water Cherenkov detector
- ▶ Study  $e/\mu/\pi^0$  energy reconstruction in a water Cherenkov detector
- ▶ Tagged gamma measurements
  - ▶  $e/\gamma$  separation in IWCD
  - ▶ Pion photoproduction in water

Discrepancy between MC in the backward direction

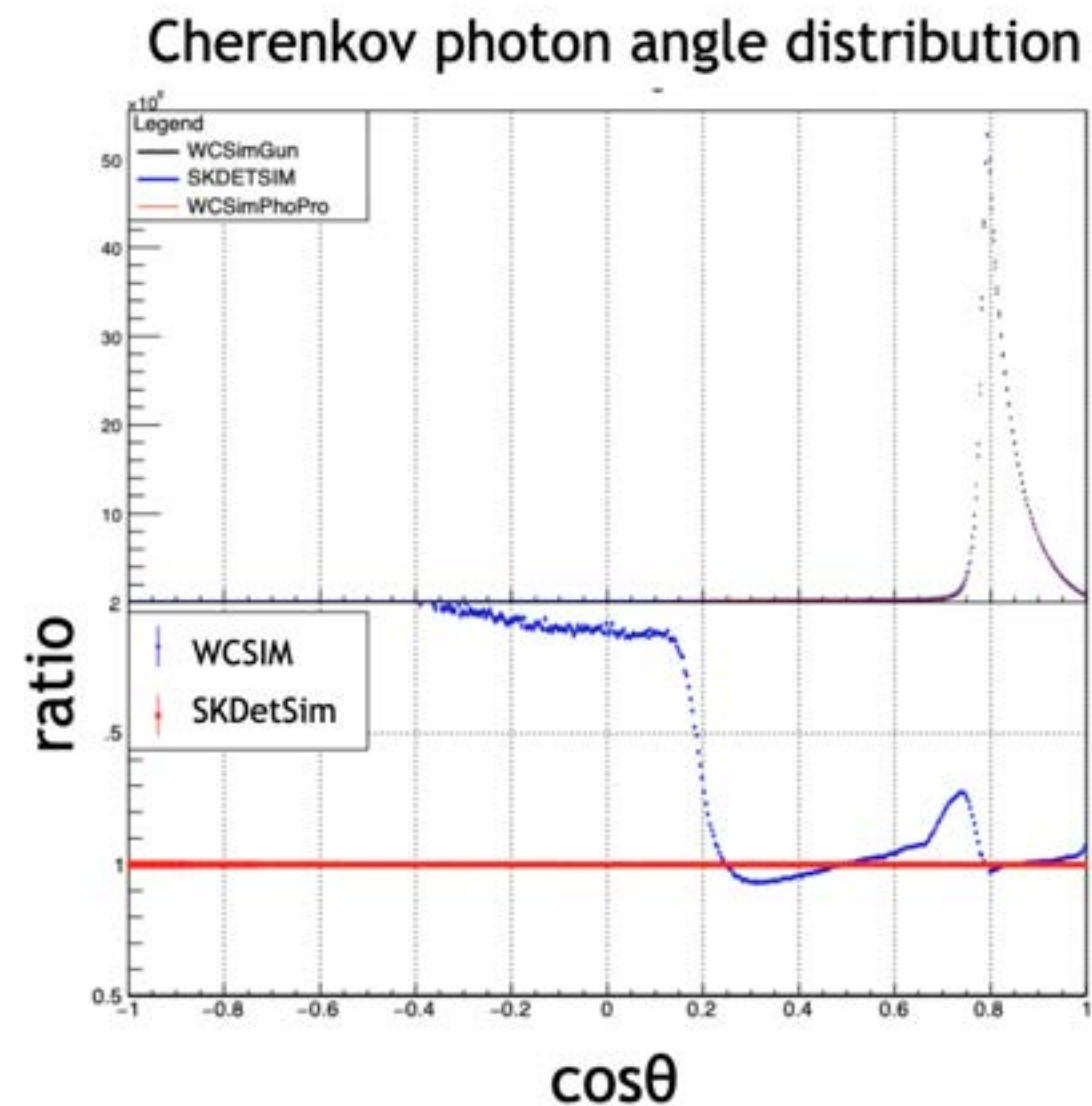

## IWCD Gamma Rejection with ML

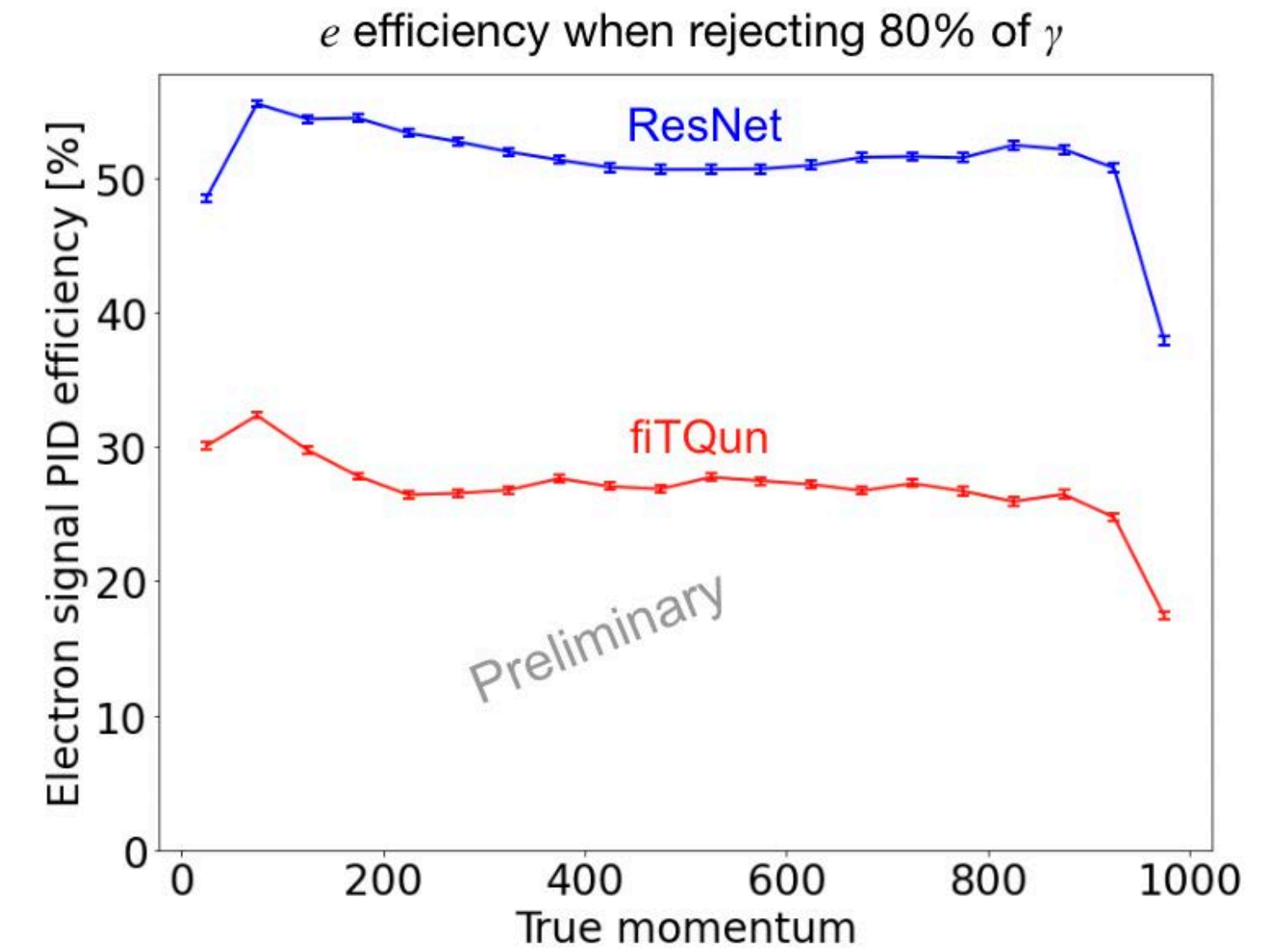

Error source	1-Ring $e$			
	FHC	RHC	FHC 1 d.e.	FHC/RHC
SK Detector	2.8	3.8	13.2	1.5
SK FSI+SI+PN	3.0	2.3	11.4	1.6
Flux + Xsec (ND unconstrained)	15.1	12.2	12.0	1.2
Flux + Xsec (ND constrained)	3.2	3.1	4.1	2.7
Nucleon Removal Energy	7.1	3.7	3.0	3.6
$\sigma(\nu_e)/\sigma(\bar{\nu}_e)$	2.6	1.5	2.6	3.0
<b>NC1<math>\gamma</math></b>	<b>1.1</b>	<b>2.6</b>	<b>0.3</b>	<b>1.5</b>
NC Other	0.2	0.3	1.0	0.2
$\sin^2 \theta_{23} + \Delta m_{21}^2$	0.5	0.3	0.5	2.0
$\sin^2 \theta_{13}$ PDG2018	2.6	2.4	2.6	1.1
All Systematics	8.8	7.1	18.4	6.0

# WCTE PHYSICS GOALS (3)

- ▶ Study pion interactions in water
  - ▶ Absorption, charge exchange, quasi-elastic scattering
- ▶ Study  $e/\mu/\pi$  PID in a water Cherenkov detector
- ▶ Study  $e/\mu/\pi^0$  energy reconstruction in a water Cherenkov detector
- ▶ Tagged gamma measurements
  - ▶  $e/\gamma$  separation in IWCD
  - ▶ Pion photoproduction in water
- ▶ High momentum measurements
  - ▶  $e/\mu$  scattering on oxygen
  - ▶ GeV proton detection for dark matter search
  - ▶ Kaon measurements for proton decay and atmospheric  $\nu_\tau$  appearance

Neutrino-nucleus scattering

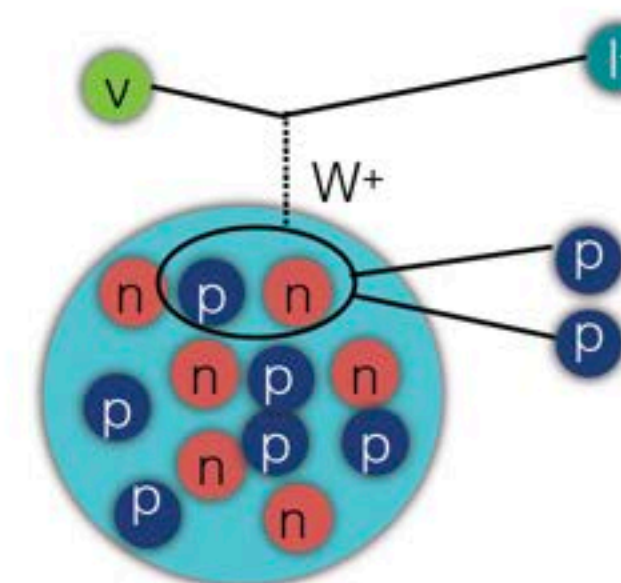

Electron/muon-nucleus scattering

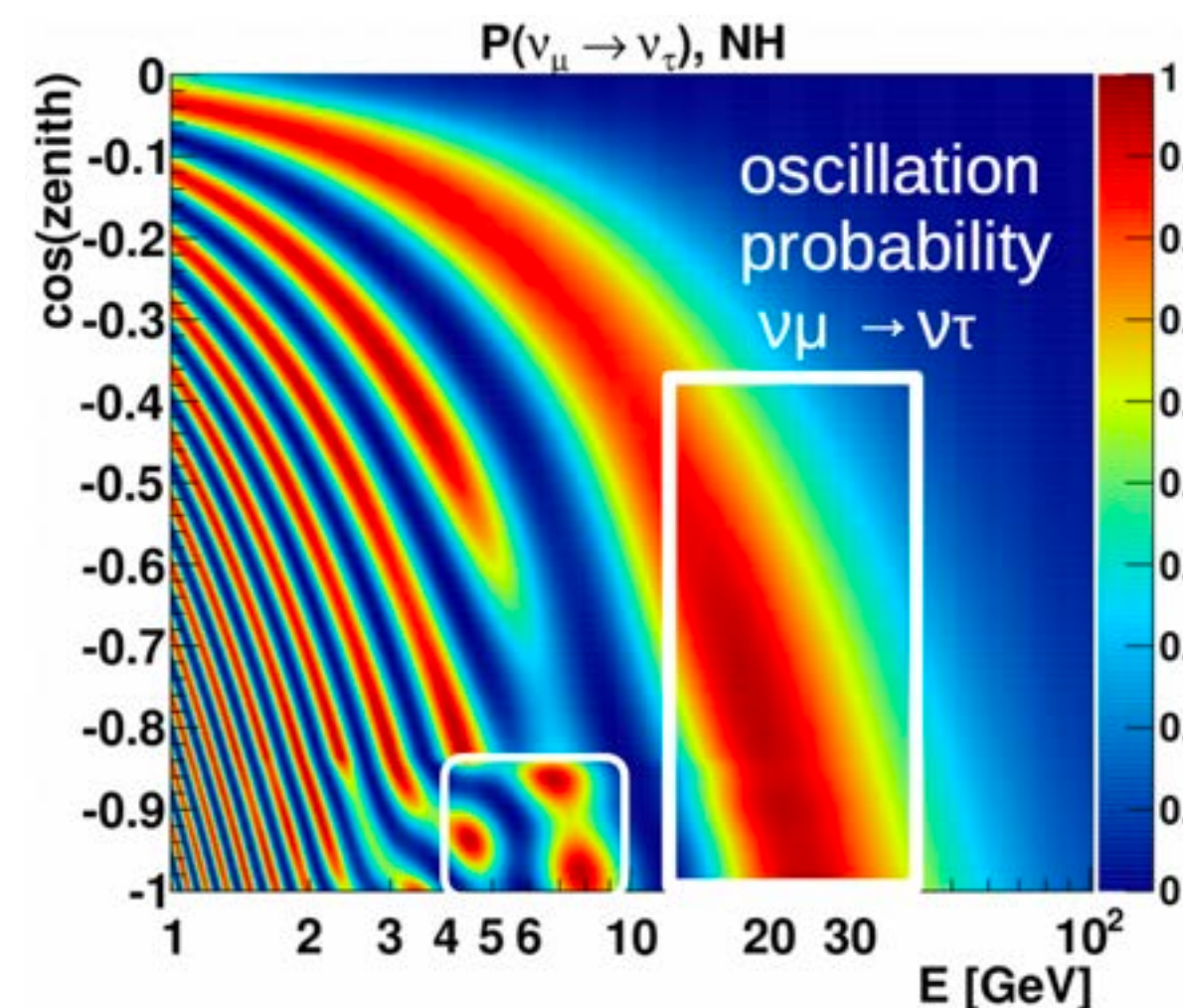
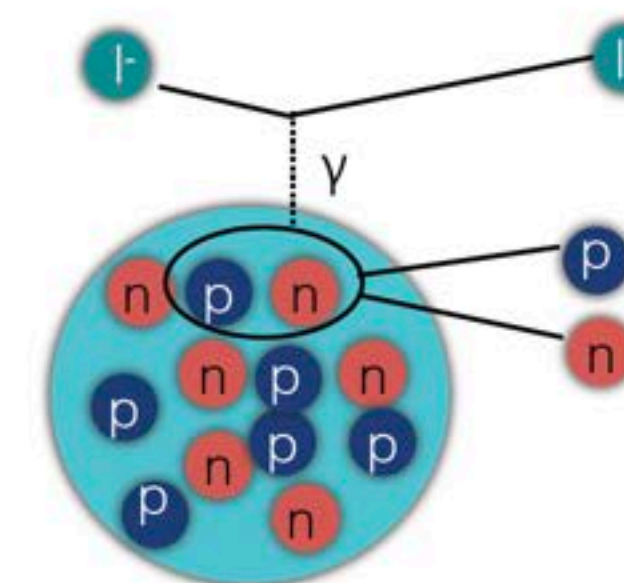

2-body  $\tau$  decay BR=0.7%:



3-4 events in the current SK data, 10-20 events for HK

Proton decay  $p \rightarrow K^+ \nu$

1.1 GeV  $K^+$  stops in the tank

# WCTE PHYSICS GOALS (4)

- ▶ Gd-phase physics
  - ▶ Neutron tagging for neutrino/antineutrino separation
    - ▶ Secondary neutron production in water from proton, stopped  $\mu^-$  and  $\pi^\pm$
- ▶ Neutron production from 2p-2h in quasi-elastic scattering
- ▶ Photonuclear reaction with gamma beam
- ▶  $^9\text{Li}$  production from  $\pi^-$ 
  - ▶ Cosmogenic  $^9\text{Li}$  are a significant background for DSNB search

Neutron production in CCQE interactions in T2K

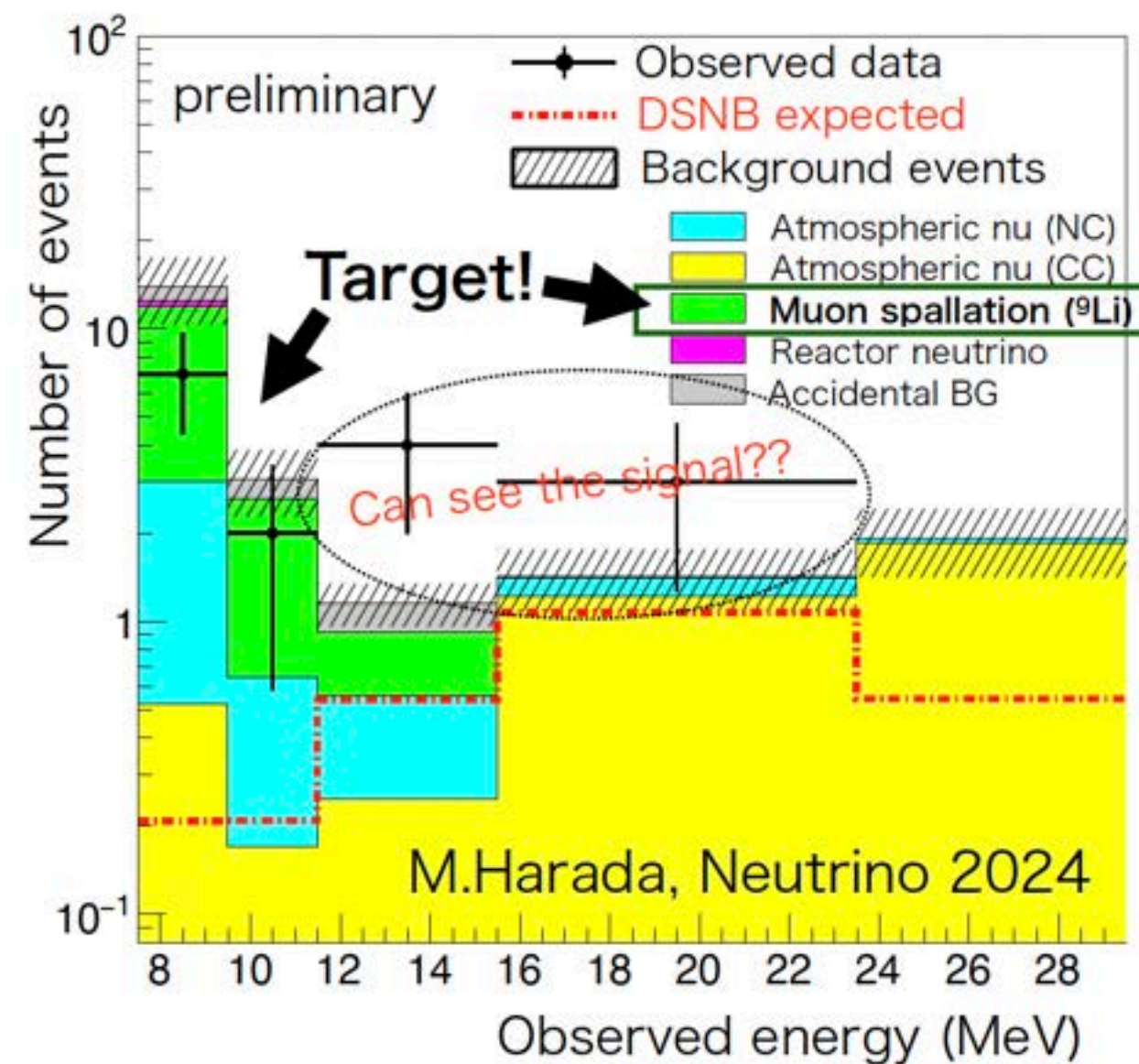
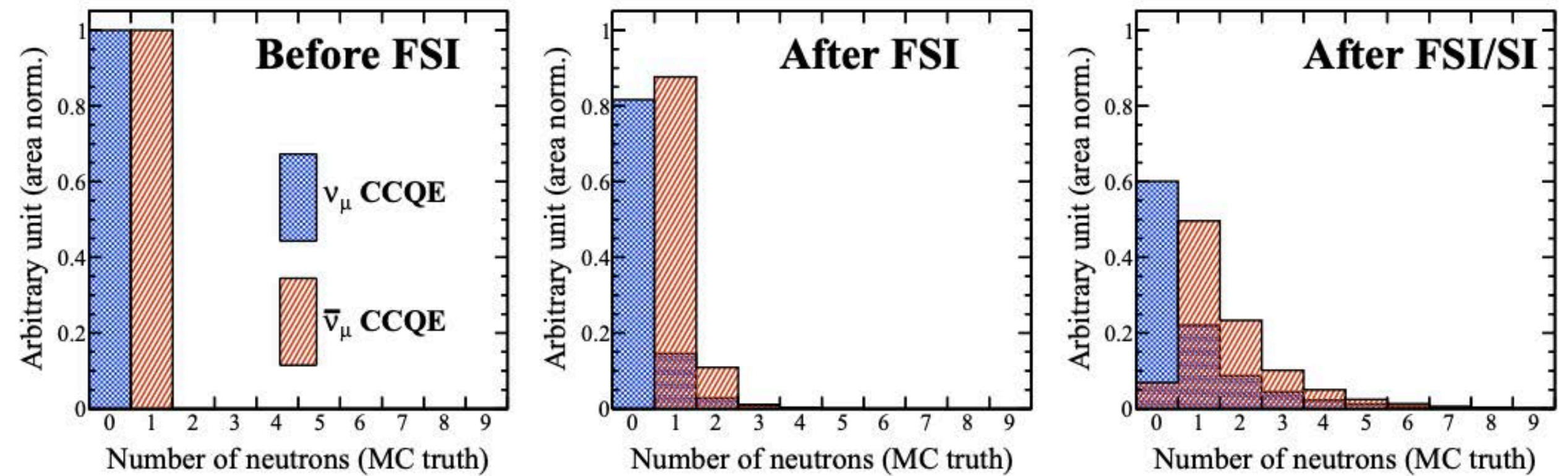

Inverse Beta Decay (IBD)

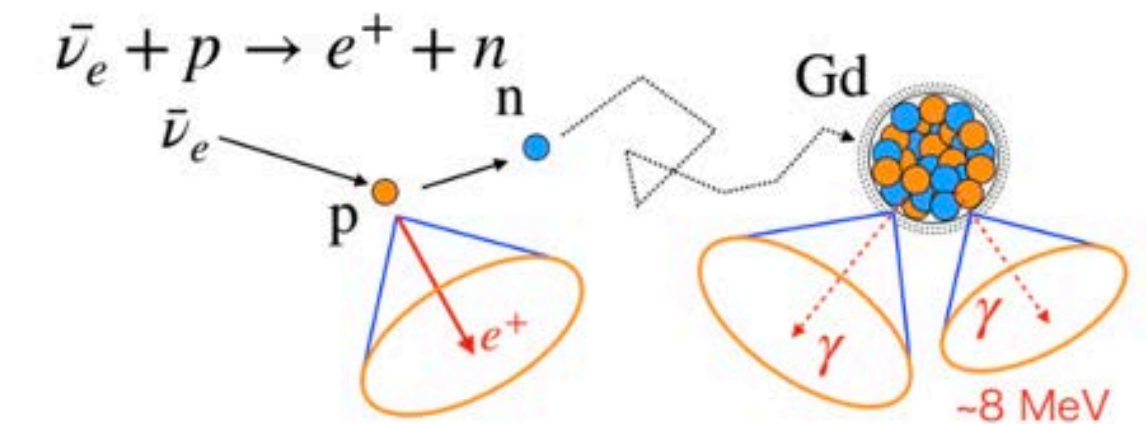

Spallation by cosmic muons

