

Hyper-Kamiokande experiment

CAP Congress
Ottawa, ON

Arturo Fiorentini - 23 June 2026



The HK experiment

- Next-generation multi-purpose underground water Cherenkov experiment in Japan
- Study of neutrino oscillations using different sources
 - Accelerator, atmospheric and solar neutrinos
- Neutrino astronomy
 - Supernova and solar neutrinos
- Nucleon decay searches (predicted in most Grand Unified Theories)
- Dark matter searches, neutrino geophysics, non-standard interactions..

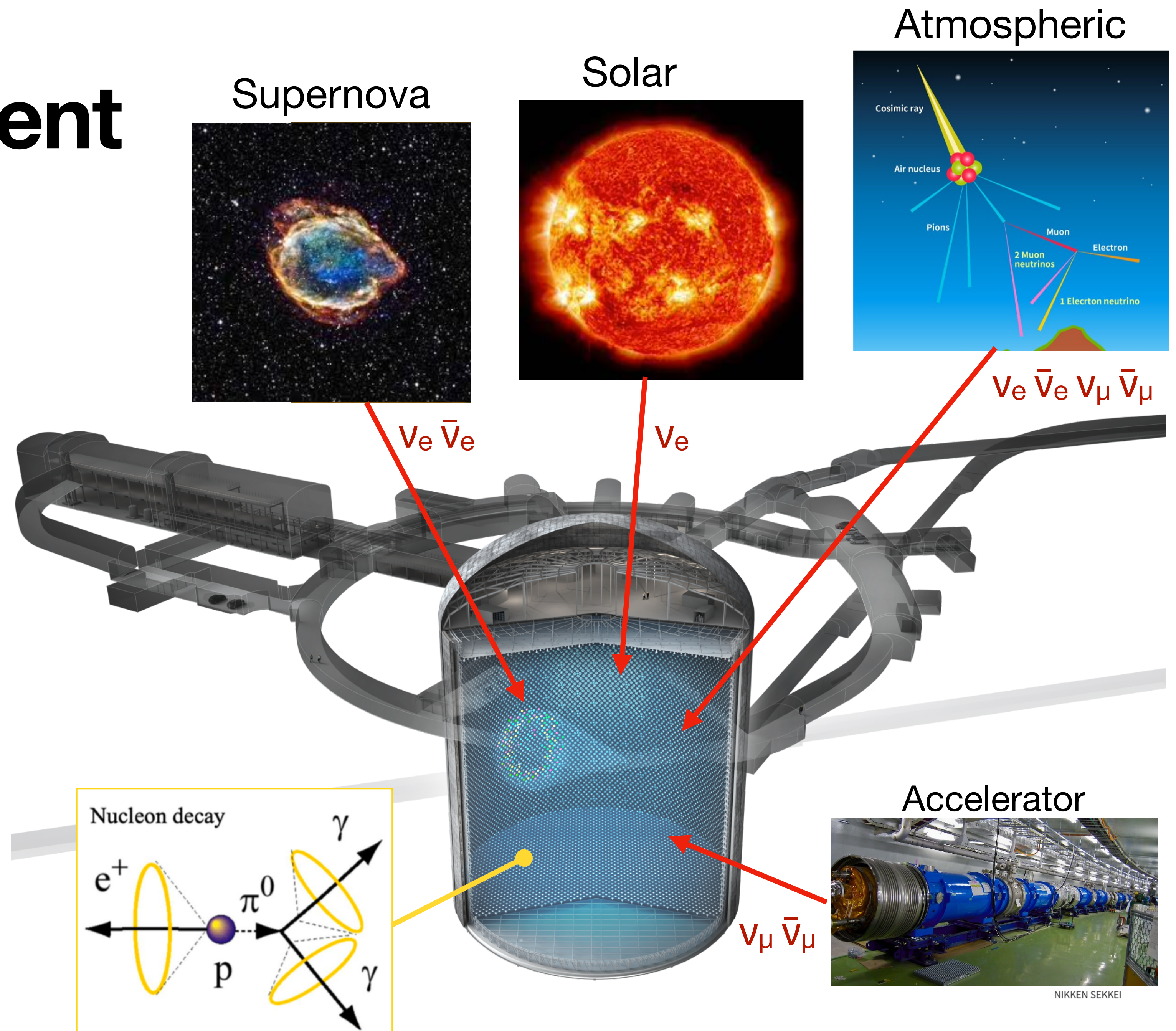

Neutrino oscillations

- Neutrinos are elementary particles described in the standard model
- Flavour eigenstates are a quantum superposition of mass eigenstates
- Neutrinos created in a given flavour can oscillate to other flavours on its way to a detector

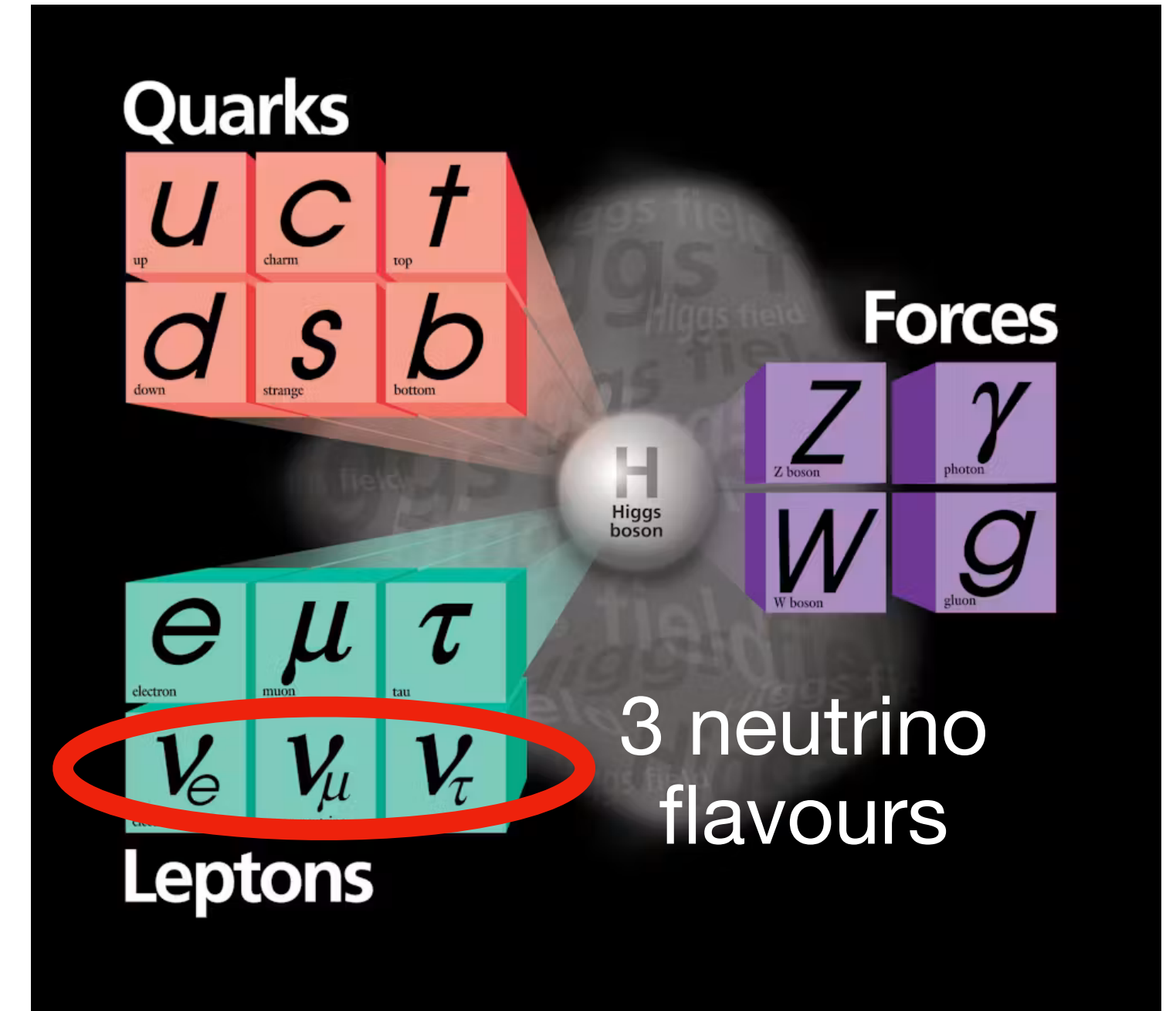

$$\begin{array}{c} \text{Flavour} \\ \text{eigenstates} \end{array} \begin{pmatrix} \nu_e \\ \nu_\mu \\ \nu_\tau \end{pmatrix} = U_{\text{PMNS}} \begin{array}{c} \text{Mass} \\ \text{eigenstates} \end{array} \begin{pmatrix} \nu_1 \\ \nu_2 \\ \nu_3 \end{pmatrix}$$

Pontecorvo-Maki-Nakagawa-Sakawa 3x3 unitary matrix

$$|e\rangle = U_{e1}|\nu_1\rangle + U_{e2}|\nu_2\rangle + U_{e3}|\nu_3\rangle$$

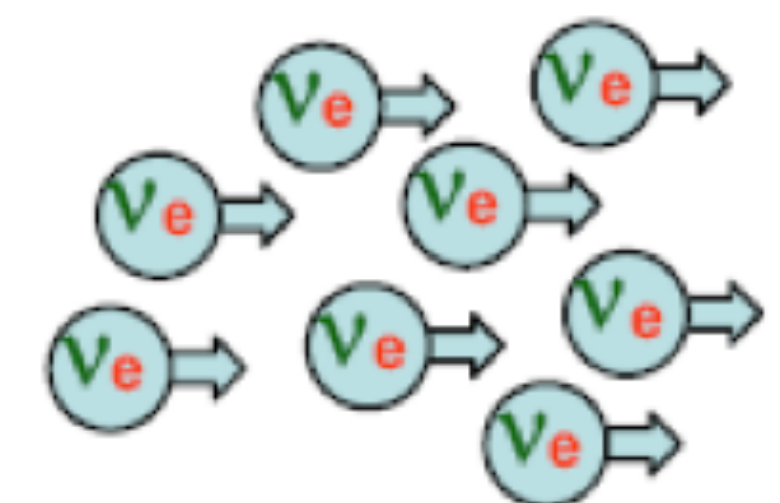
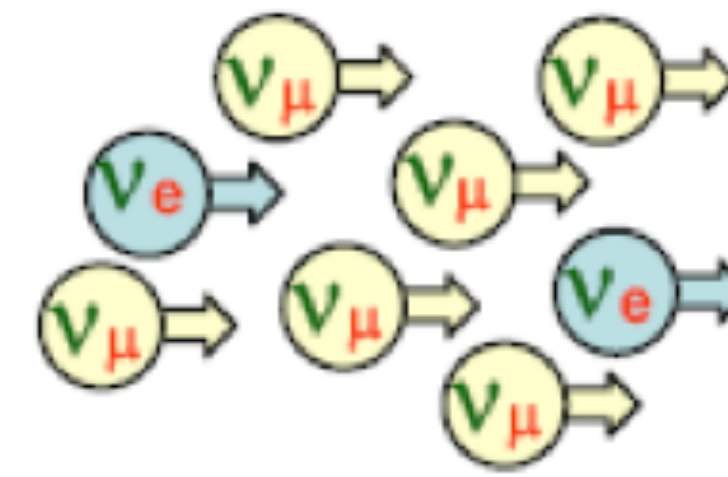
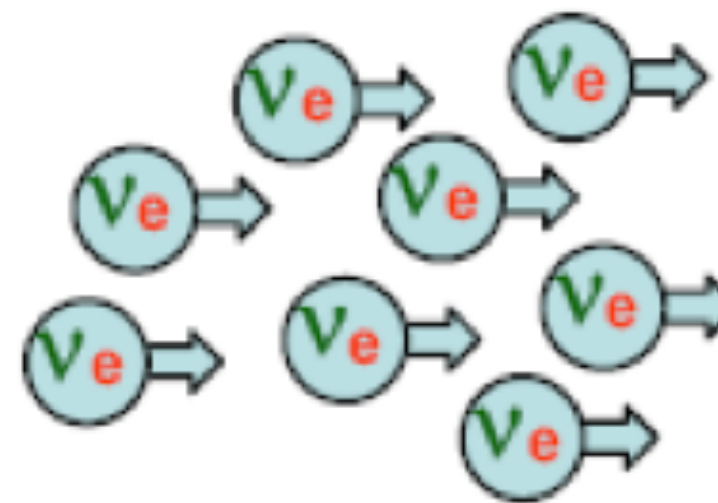

$$|\phi(t)\rangle = U_{e1}e^{ip_1x}|\nu_1\rangle + U_{e2}e^{ip_2x}|\nu_2\rangle + U_{e3}e^{ip_3x}|\nu_3\rangle$$

Neutrino oscillations parameters

$$(c_{ij} = \cos\theta_{ij}, s_{ij} = \sin\theta_{ij})$$

The PMNS matrix

$$U_{\text{PMNS}} = \begin{pmatrix} 1 & 0 & 0 \\ 0 & +c_{23} & +s_{23} \\ 0 & -s_{23} & +c_{23} \end{pmatrix} \begin{pmatrix} +c_{13} & 0 & +s_{13}e^{-i\delta} \\ 0 & 1 & 0 \\ -s_{13}e^{i\delta} & 0 & +c_{13} \end{pmatrix} \begin{pmatrix} +c_{12} & +s_{12} & 0 \\ -s_{12} & +c_{12} & 0 \\ 0 & 0 & 1 \end{pmatrix}$$

Atmospheric/
Accelerator

$\theta_{23} = 41.11^\circ \rightarrow 50.02^\circ$

Reactor/
Accelerator

$\theta_{13} = 8.27^\circ \rightarrow 8.95^\circ$

Solar/Reactor

$\theta_{12} = 32.54^\circ \rightarrow 35.03^\circ$

- Three mixing angles ($\theta_{12}, \theta_{13}, \theta_{23}$)
 - Is $\theta_{23} = 45^\circ$ (maximal mixing)? If not, $\theta_{23} < 45^\circ$ or $\theta_{23} > 45^\circ$ (octant)?
- One CP violation (CPV) phase δ_{CP}
 - Is CP violated in the lepton sector ($\delta_{\text{CP}} \neq 0$)? Do ν and $\bar{\nu}$ oscillate differently?
- Two mass splittings
 - Is $\Delta m_{32}^2 > 0$ or $\Delta m_{32}^2 < 0$? Which neutrino is the lightest?

Neutrino mass hierarchy

$$\Delta m_{21}^2 \approx (7.5 \pm 0.3) \times 10^{-5} eV^2$$

$$|\Delta m_{32}^2| \approx (2.5 \pm 0.1) \times 10^{-3} eV^2$$

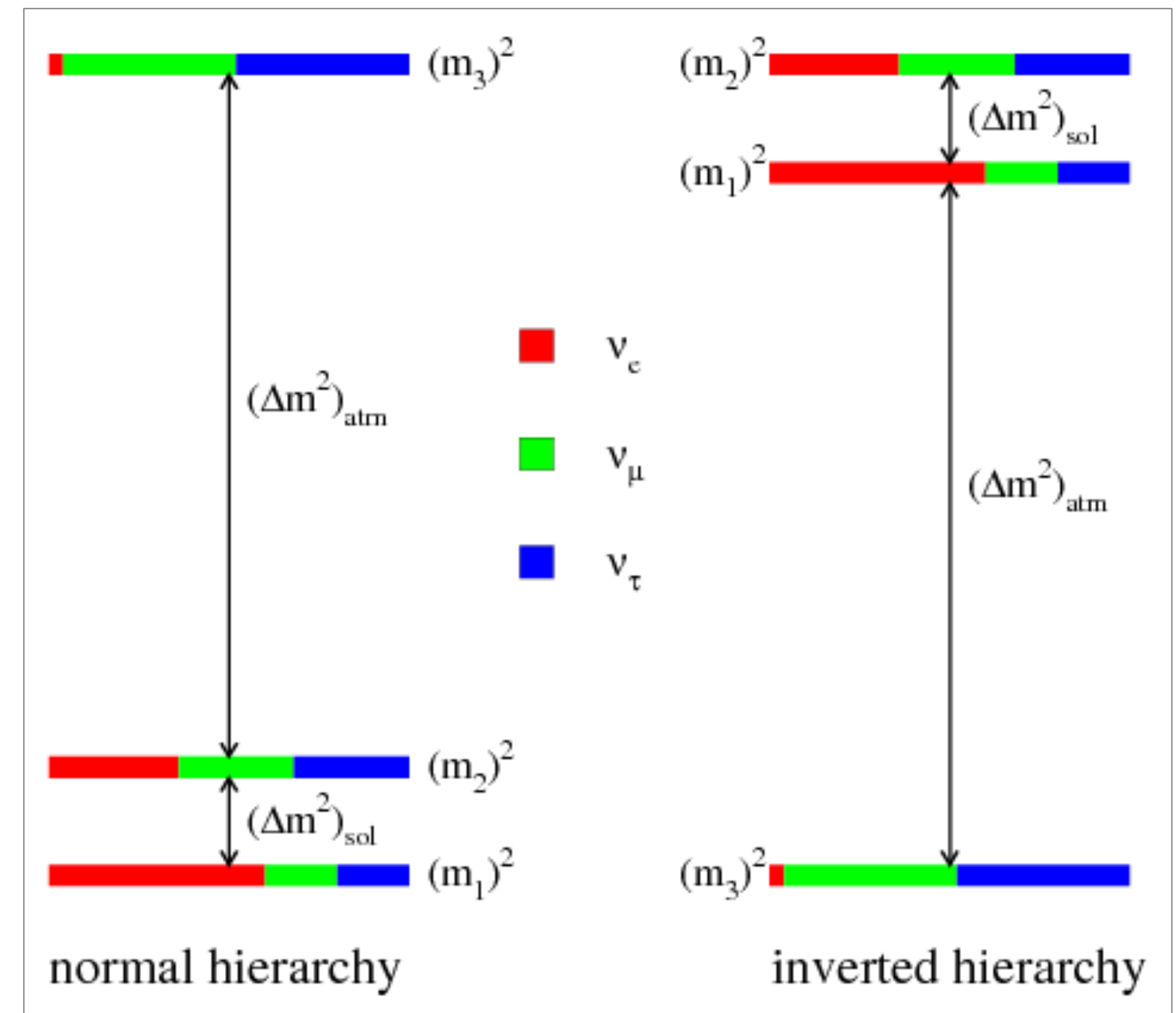

Current δ_{CP} measurements

Nature 646, 818–824 (2025)

- NOvA: ambiguity as to which ordering and δ_{CP} values are preferred
- T2K: $\delta_{CP} = -\pi/2$ is preferred in both orderings
- NOvA & T2K joint fit:
 - Wide range of allowed δ_{CP} values in normal ordering
 - $\delta_{CP}=0$ is outside 3σ range in inverted ordering
 - Slight preference for upper octant ($\sin^2\theta_{23}>0.5$)
- Futures experiments (like HK) goal is to make more conclusive measurements

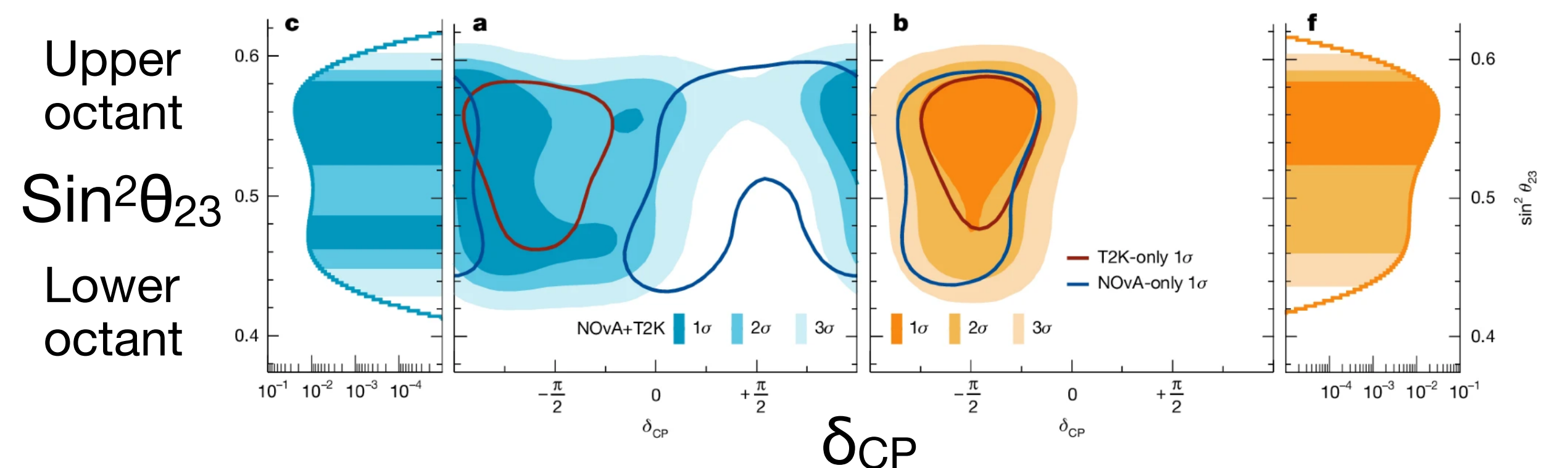
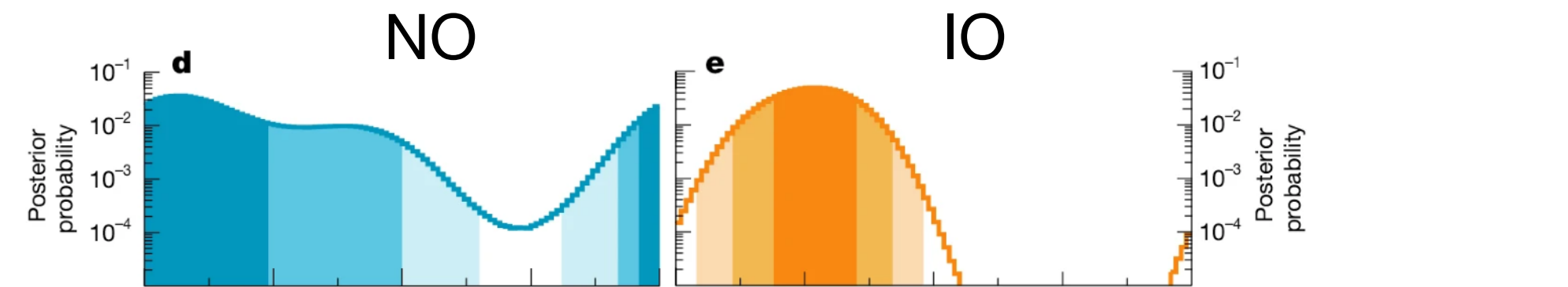
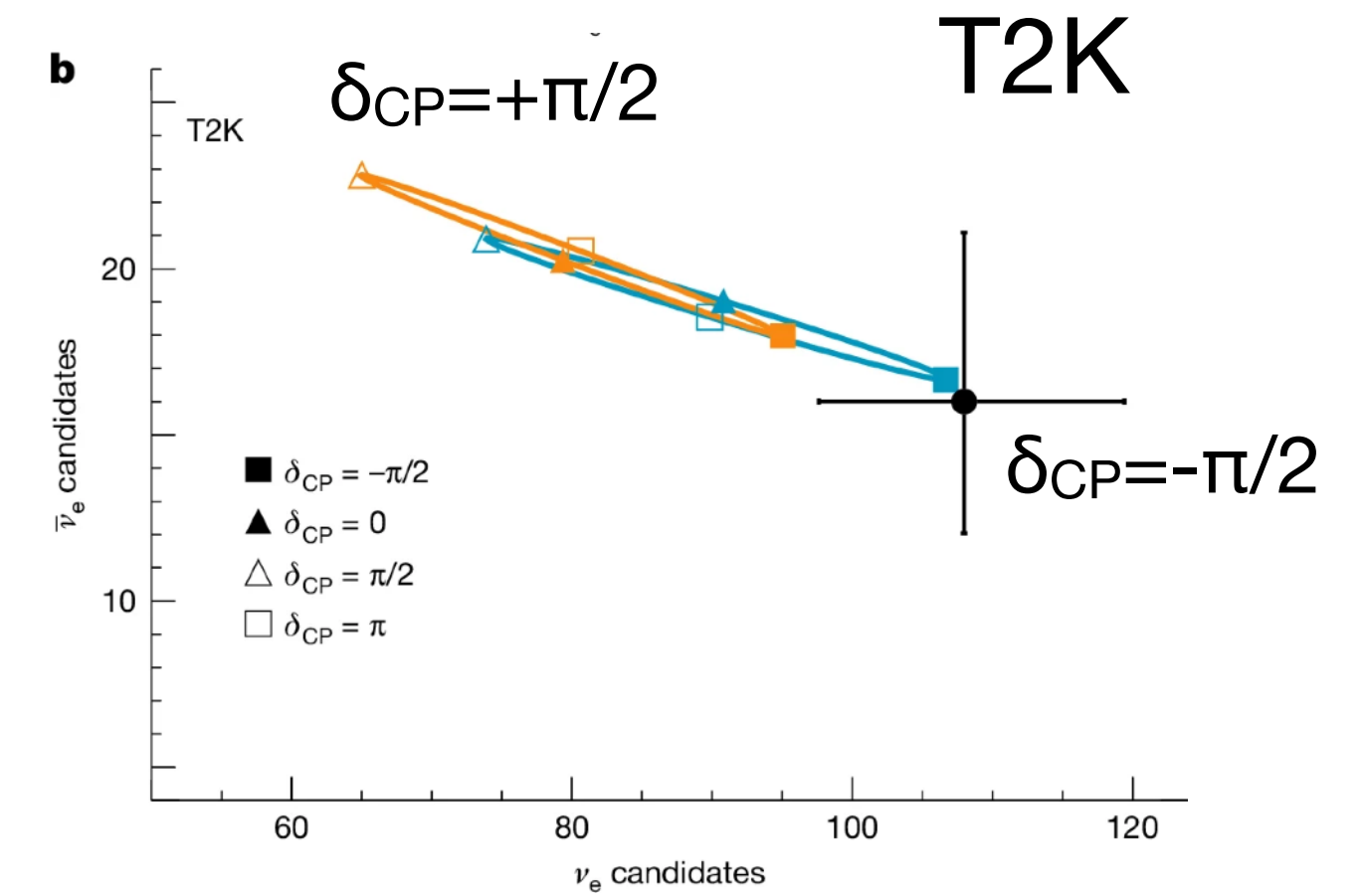
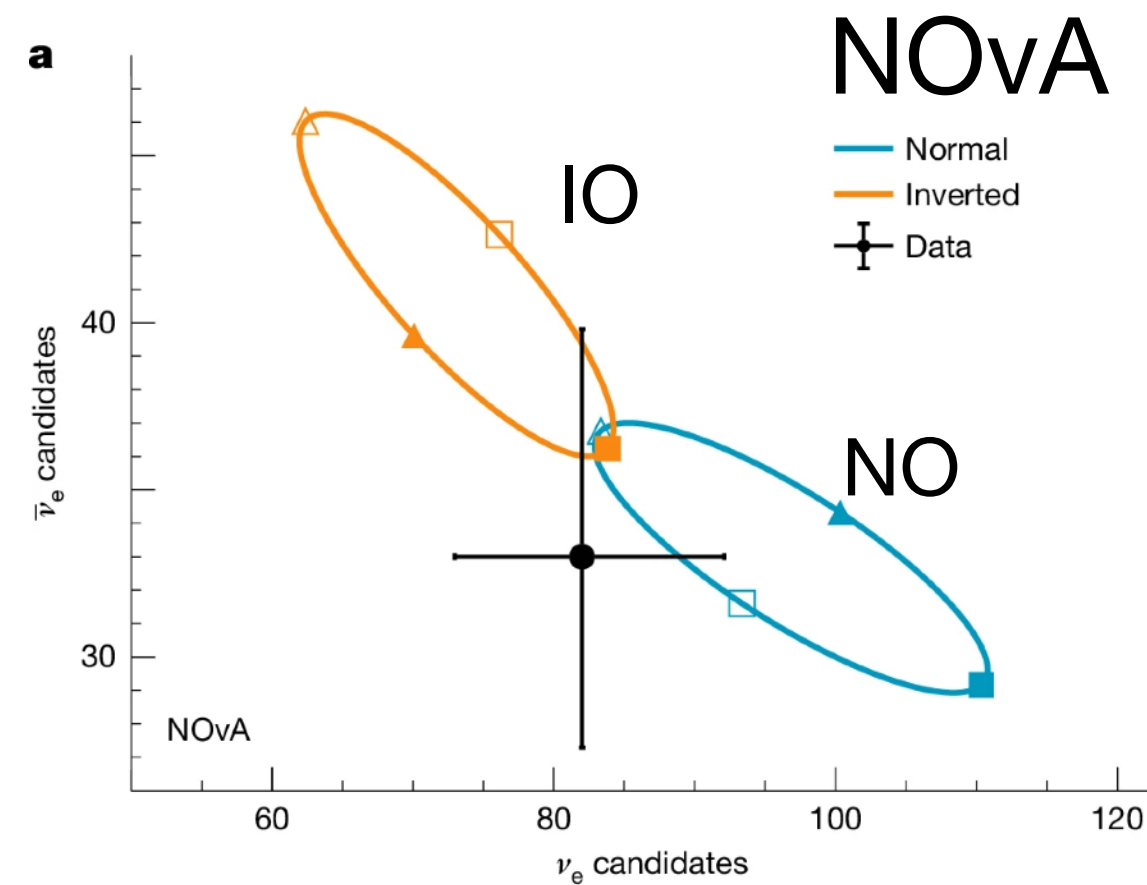

HK long-baseline program

- Accelerator-based neutrino oscillation experiment that builds on the T2K experiment experience
 - Upgraded J-PARC ν beamline and near detectors
 - New intermediate water Cherenkov detector (IWCD)
 - HK as far detector
- Designed to measure ν_e ($\bar{\nu}_e$) appearance and ν_μ ($\bar{\nu}_\mu$) disappearance with a 295 km baseline (oscillation maximum position)
 - Sensitive to m^2_{32} , θ_{13} , θ_{23} and δ_{CP}

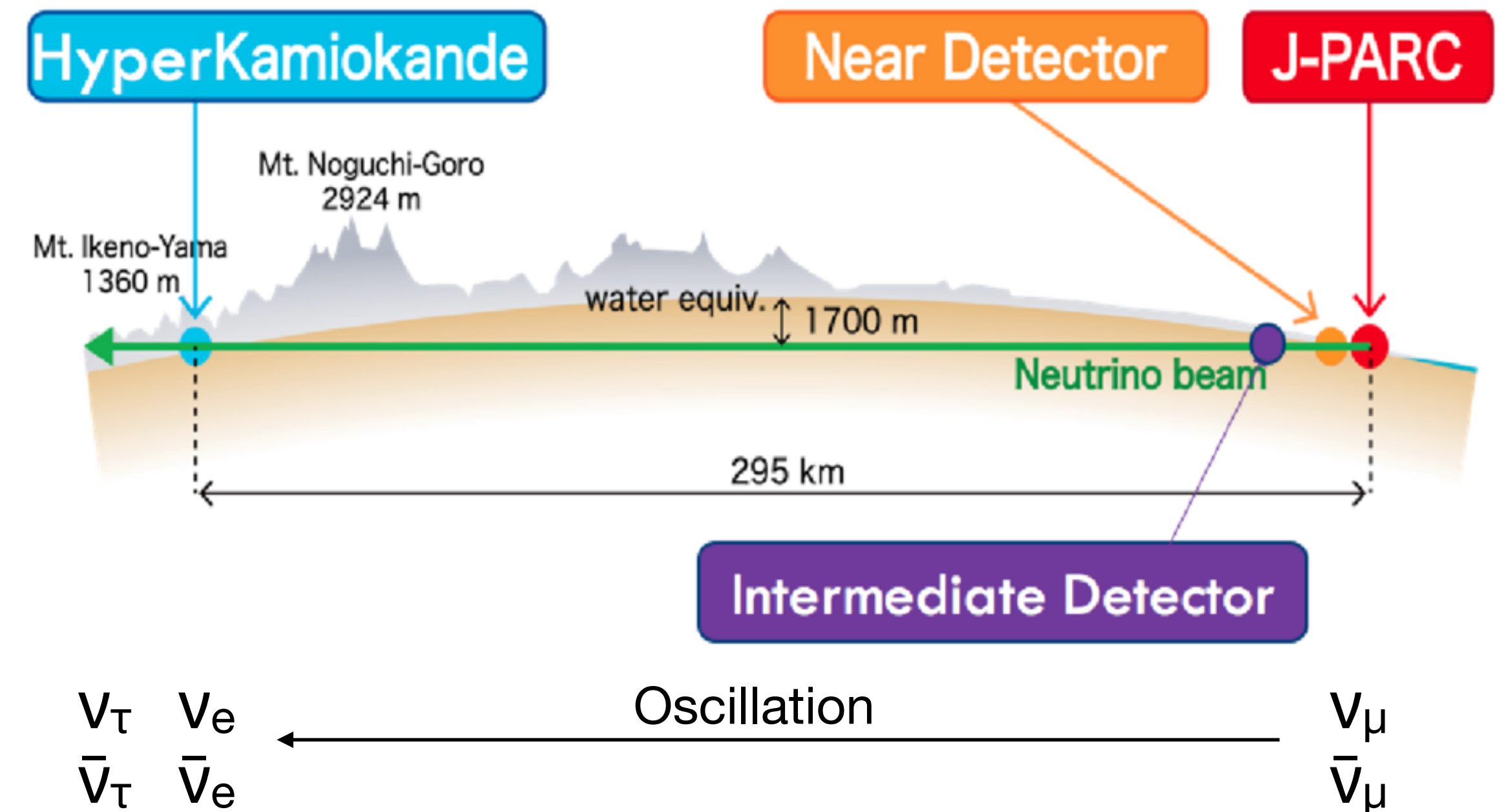

$\nu_\mu/\bar{\nu}_\mu$ enhanced beam at 2.5°

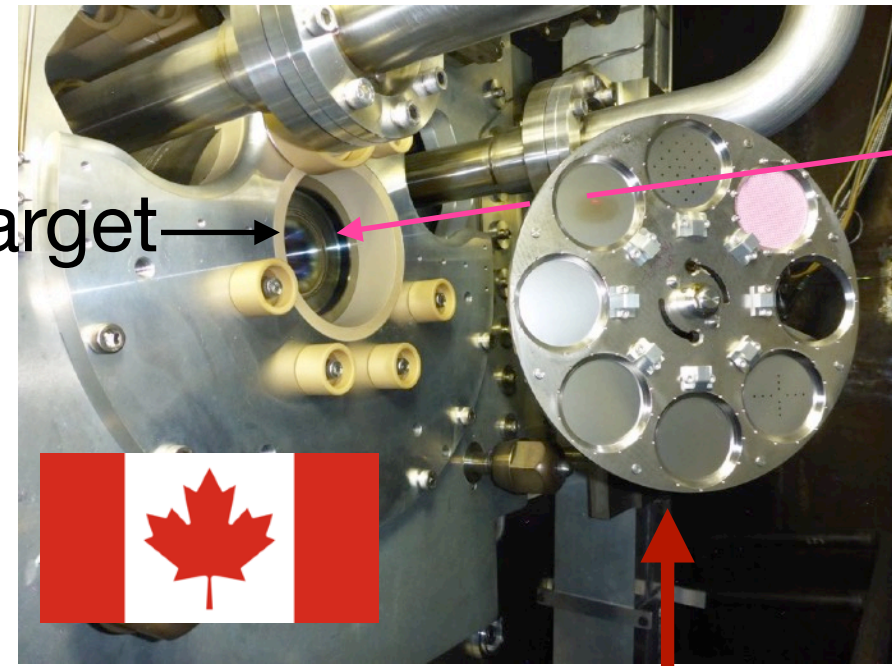

OTR monitor measures proton beam position 30cm upstream the graphite target (Canada contribution)

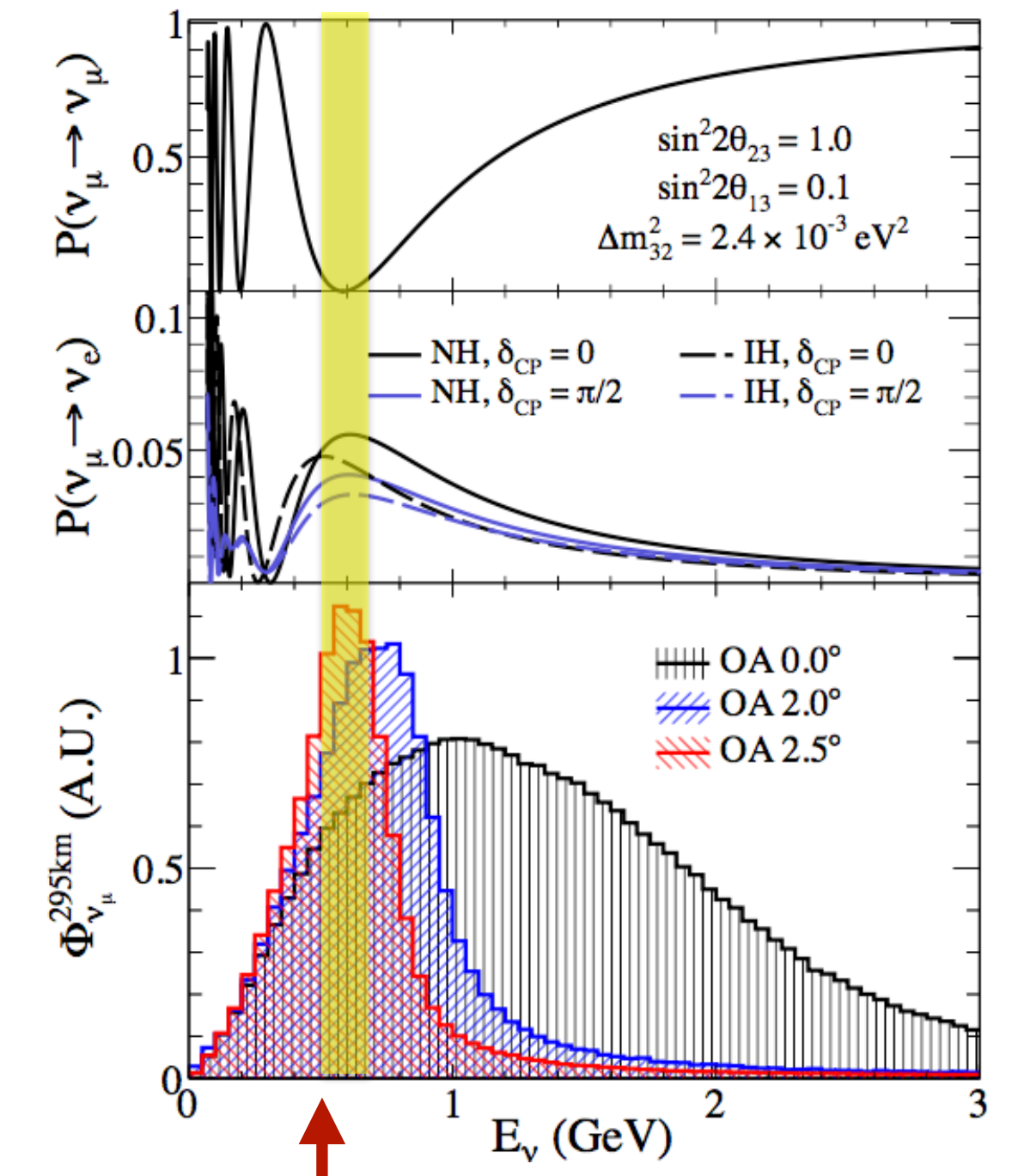
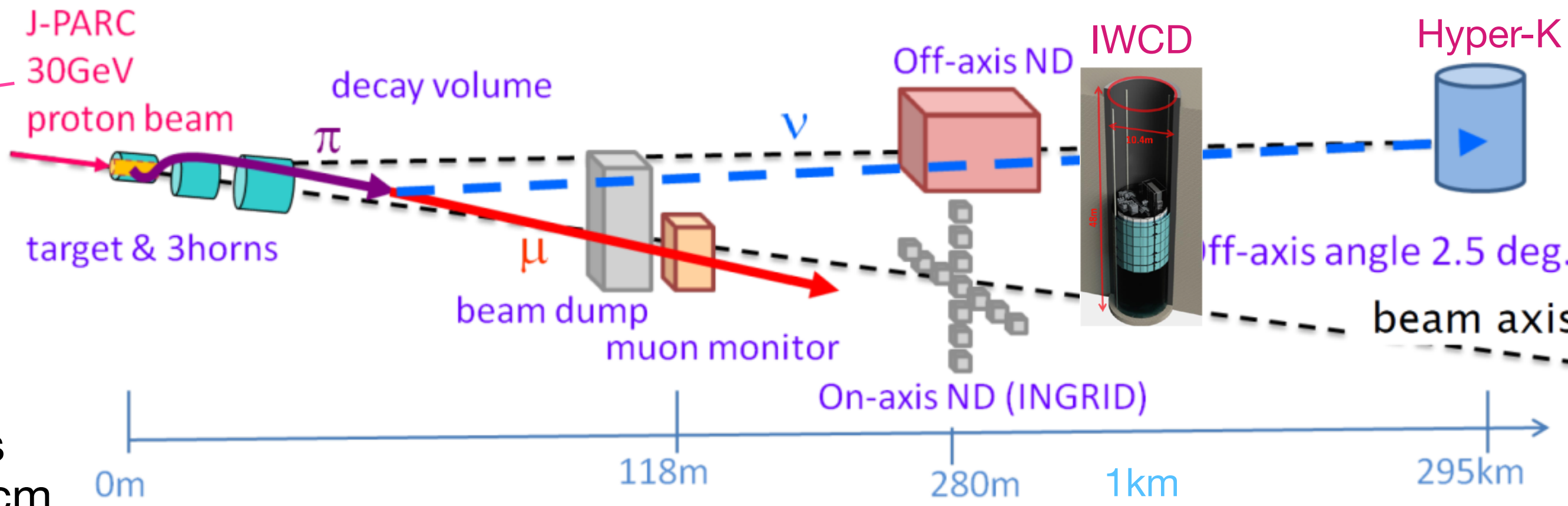

Energy peak at oscillation maximum

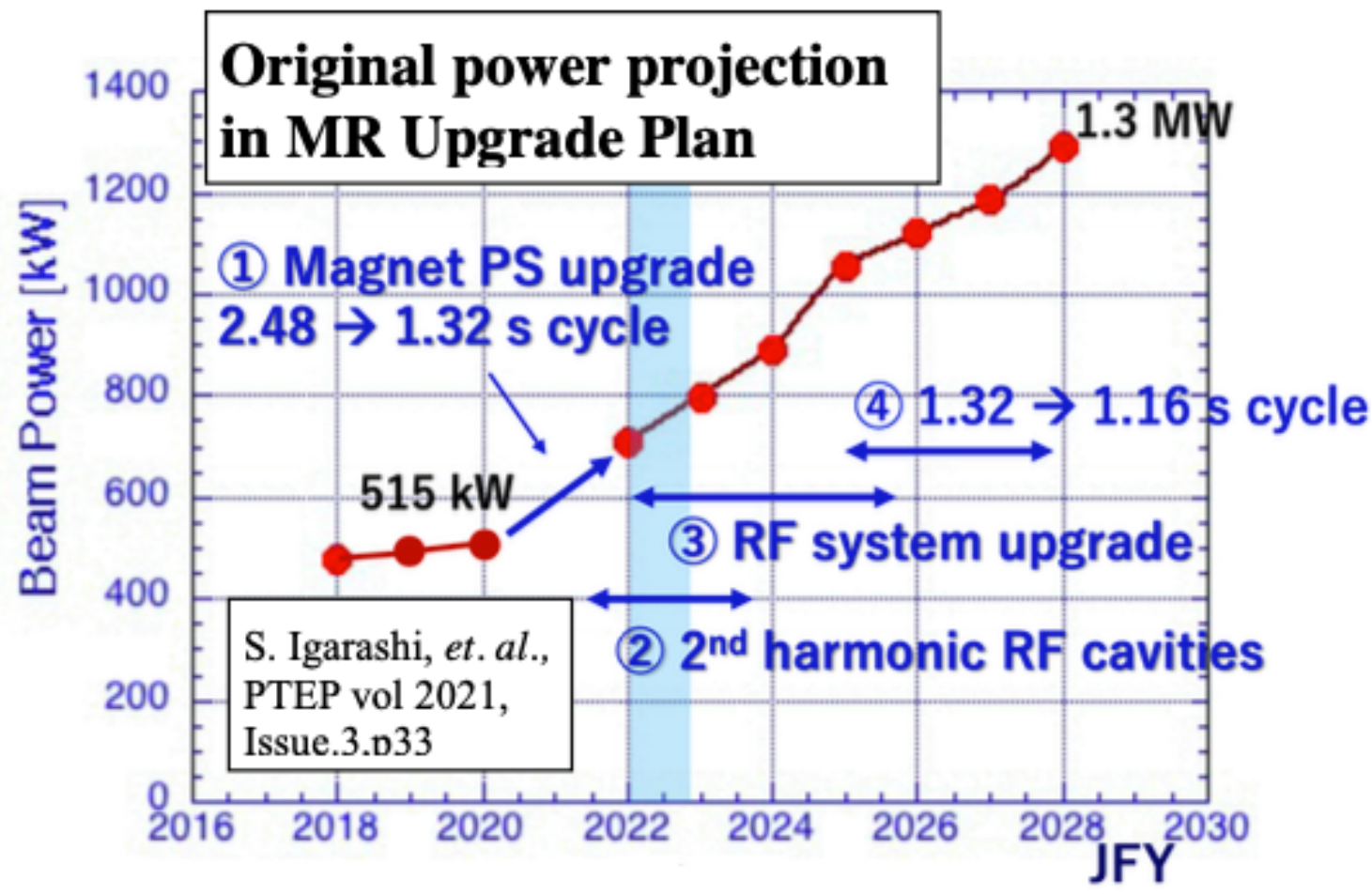

- Proton beam on graphite target produces hadrons that are focused by 3 magnetic horns and decay to produce mostly ν_μ or $\bar{\nu}_\mu$ depending on magnetic horn polarity
- **HK located at a off-axis angle = 2.5°** (proposed by Canada) where the narrow neutrino energy peak (0.6 GeV) matches the oscillation maximum at 295km
- **J-PARC power to 1.3MW by 2028** when HK starts operation

Near detectors (280m from beam source)

- ND280++ (2.5° off-axis)
 - Upgrade of T2K's ND280
 - Magnetized detector with a fine-grained tracker as target and TPC for particle ID
 - Study of ν beam composition before oscillations and neutrino cross-sections
- INGRID (on-axis)
 - 16 iron/scintillator modules as tracking calorimeters
 - Monitors ν beam direction and stability

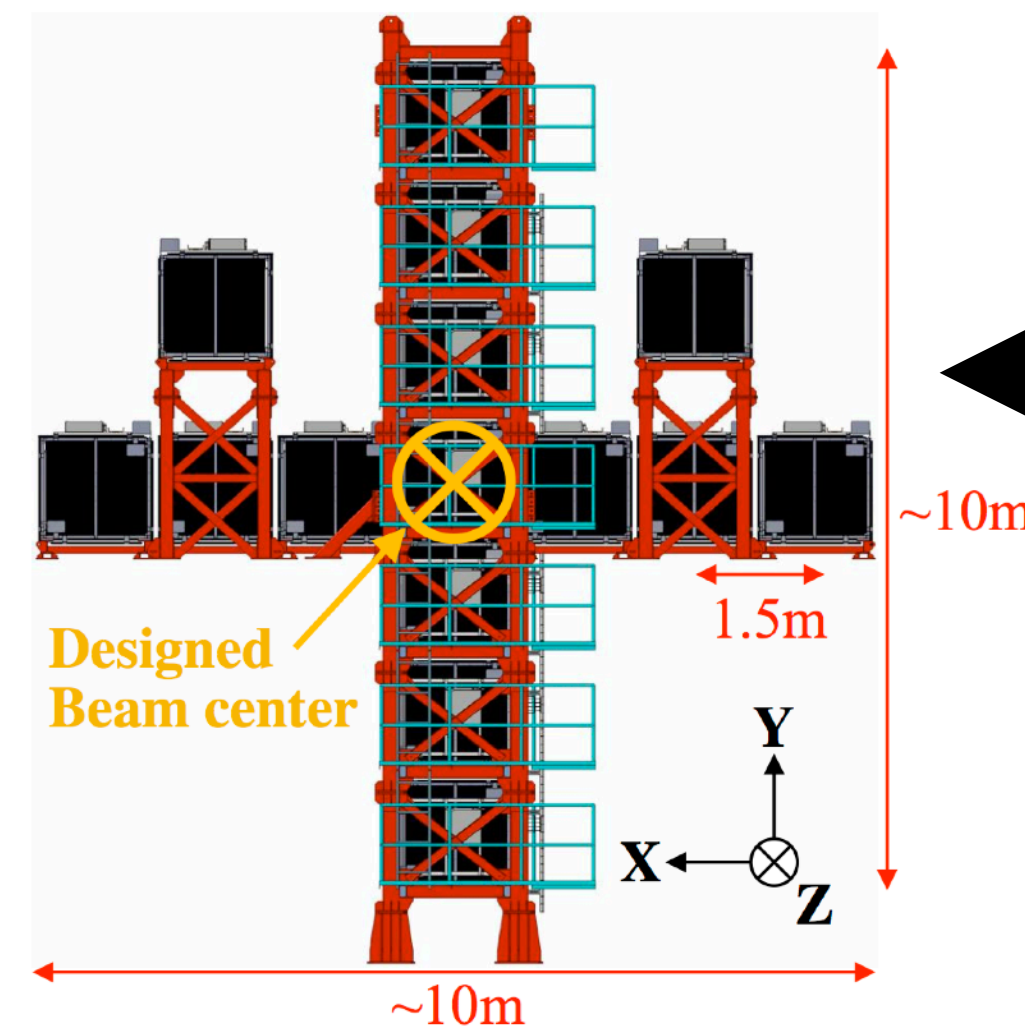
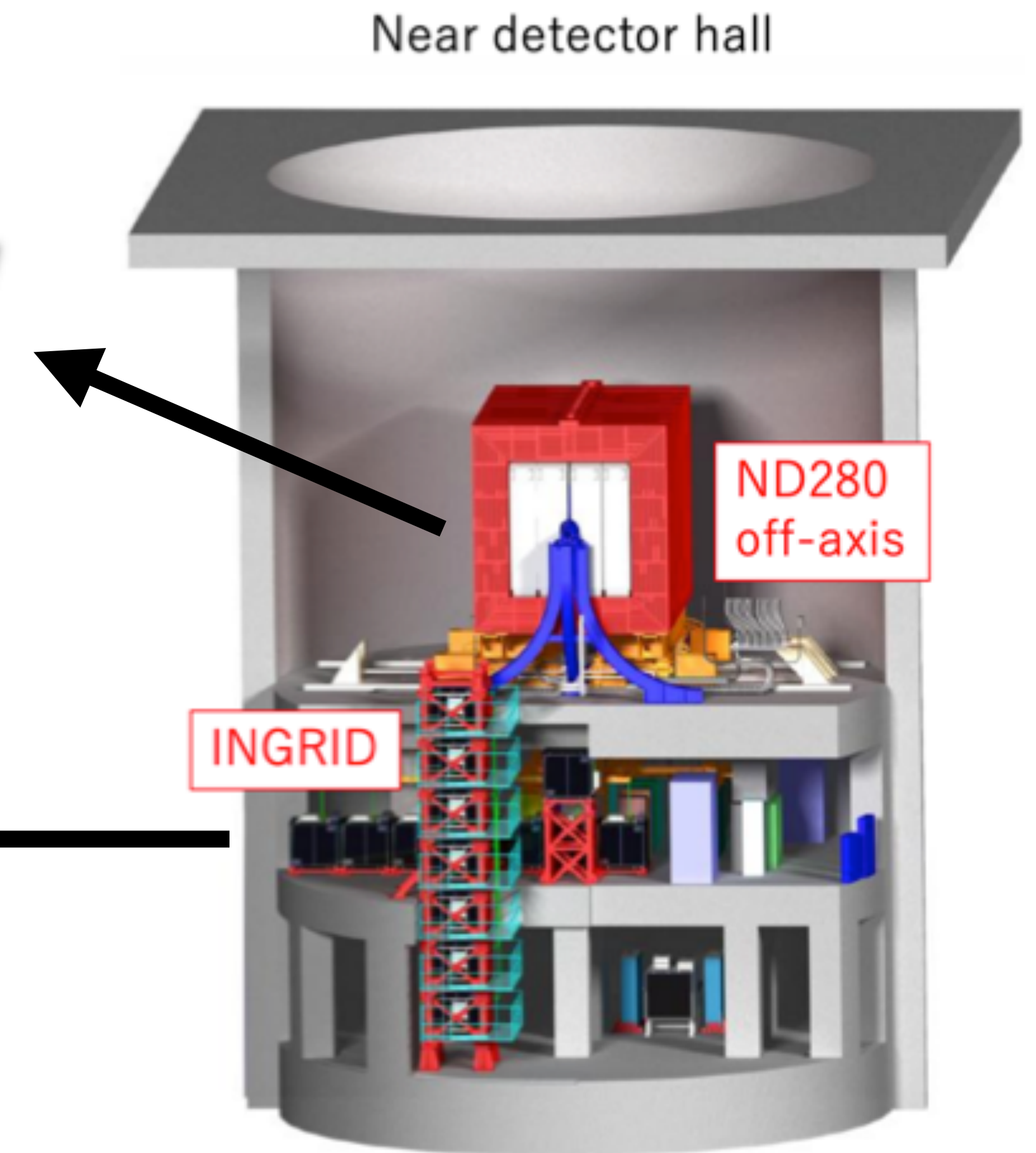
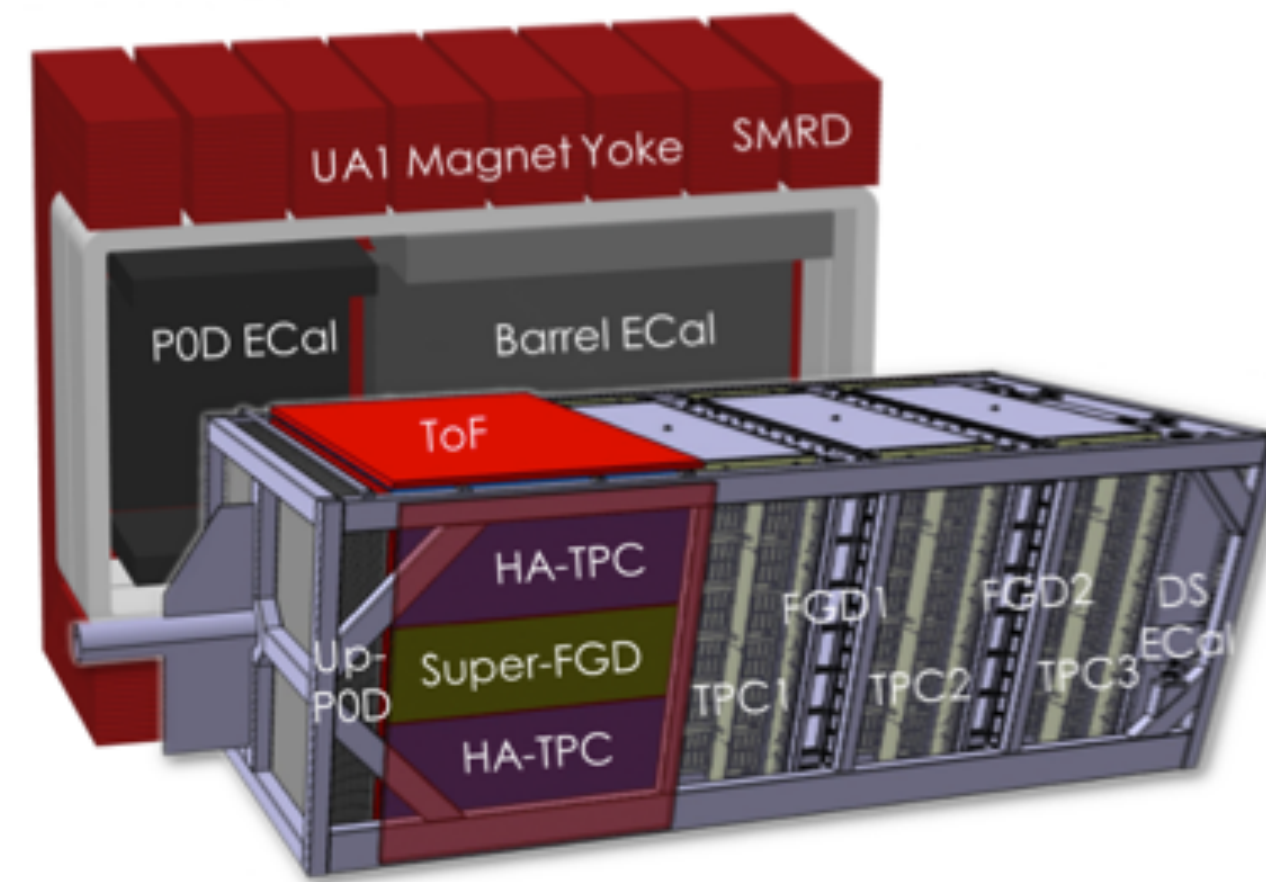

Intermediate Water Cherenkov Detector (IWCD)

- Vertically movable detector (7m \varnothing x 8m) spanning off-axis angles from 1.6° to 4° and located ~ 1 km from the source
- Constraint ν flux and interactions models in water before oscillations and at different neutrino energies ranges
- ~ 300 mPMT modules, most of them built in Canada
- Facilities construction and pit excavation are ongoing

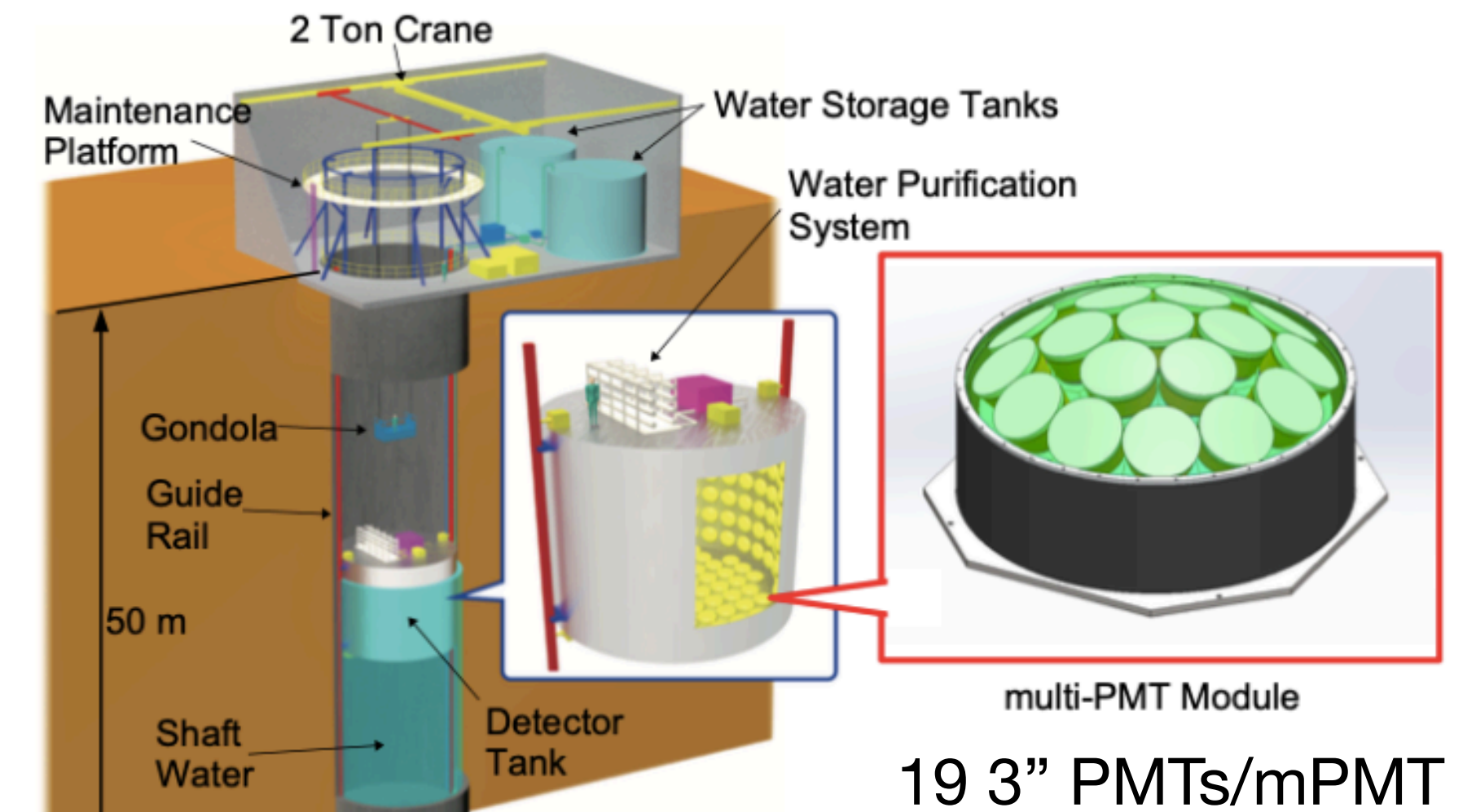

- WCTE: successful 4mx4m water Cherenkov prototype that ran at CERN's T9 beamline in 2024
- See Xiaoyue Li's talk about WCTE, (PPD) R2-1

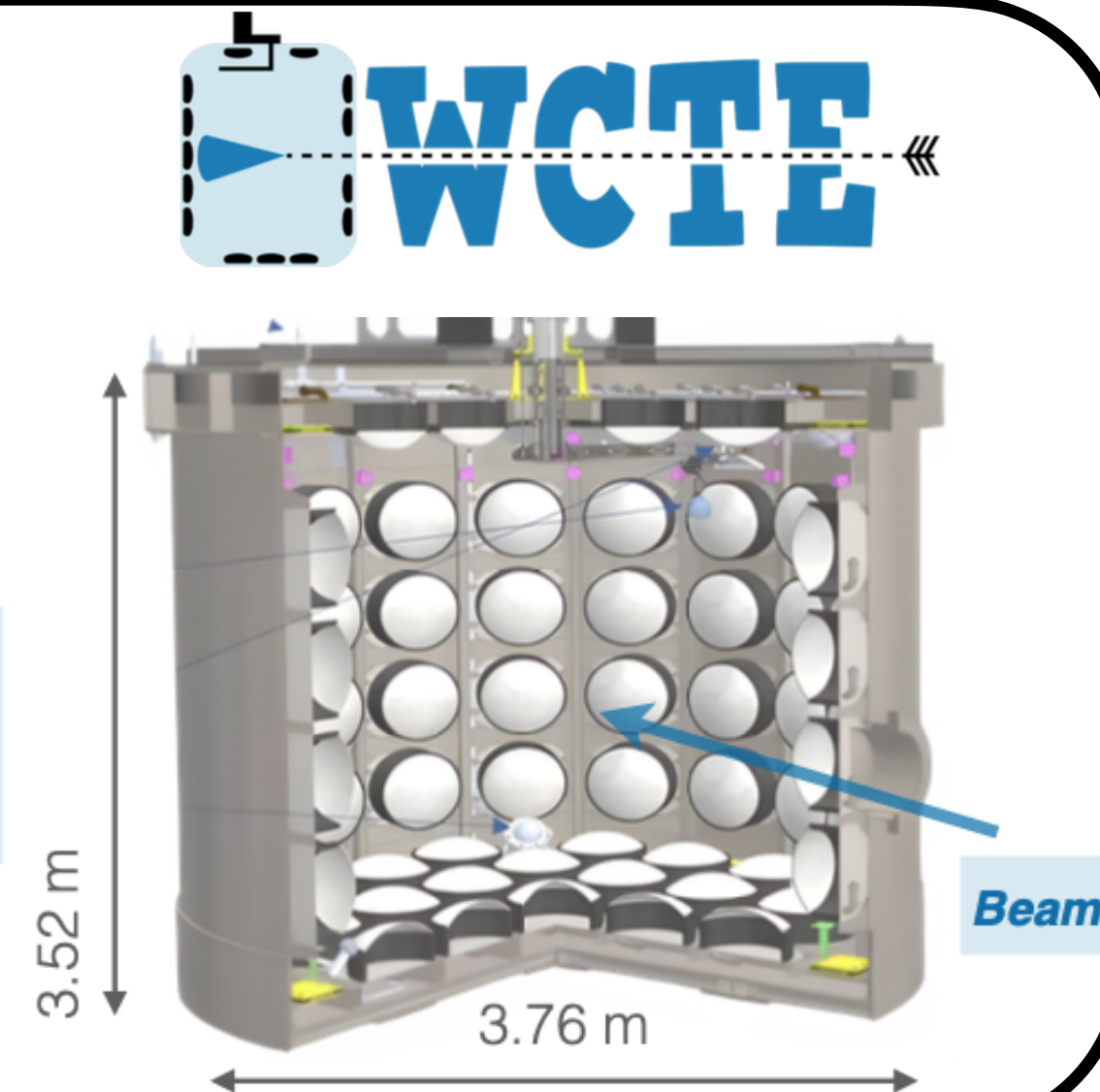

IWCD and WCTE were proposed and led by Canada

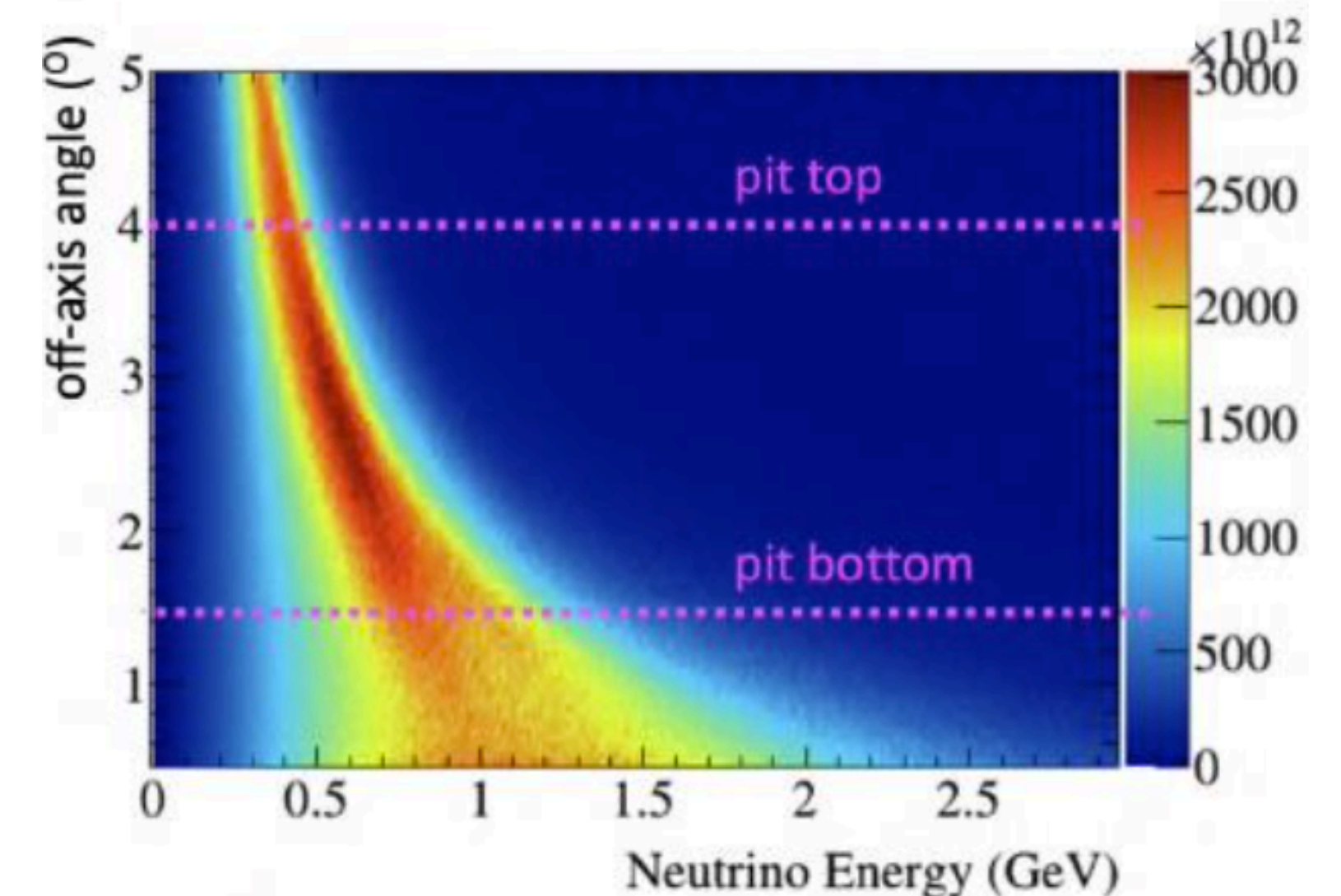

The far detector (HK)

- 3rd generation large water Cherenkov in Japan
- HK builds on many years of SK experience

Kamiokande (1983-1995)
19m \varnothing x 16m tall
Fiducial mass: 0.68kton

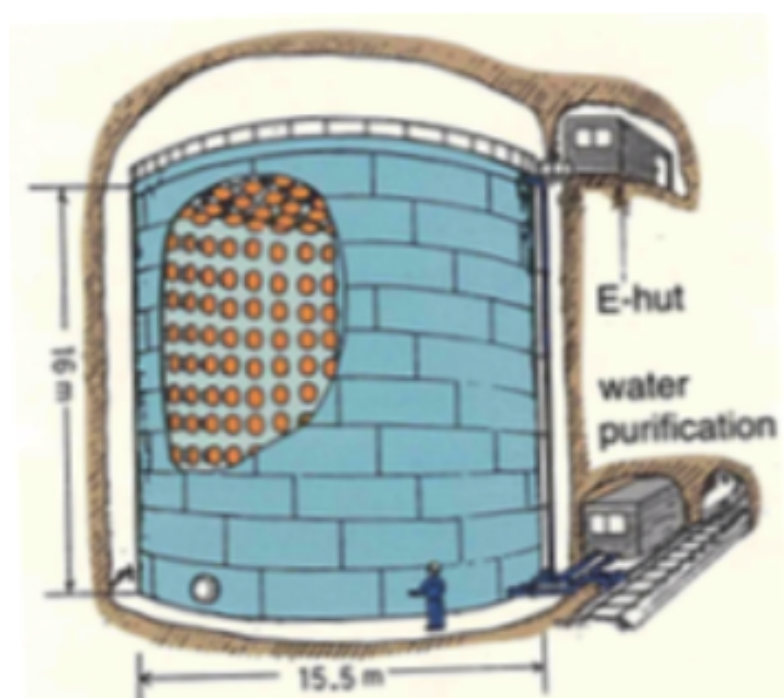

SK (1996-ongoing)
39m \varnothing x 41m tall
Fiducial mass: 22kton

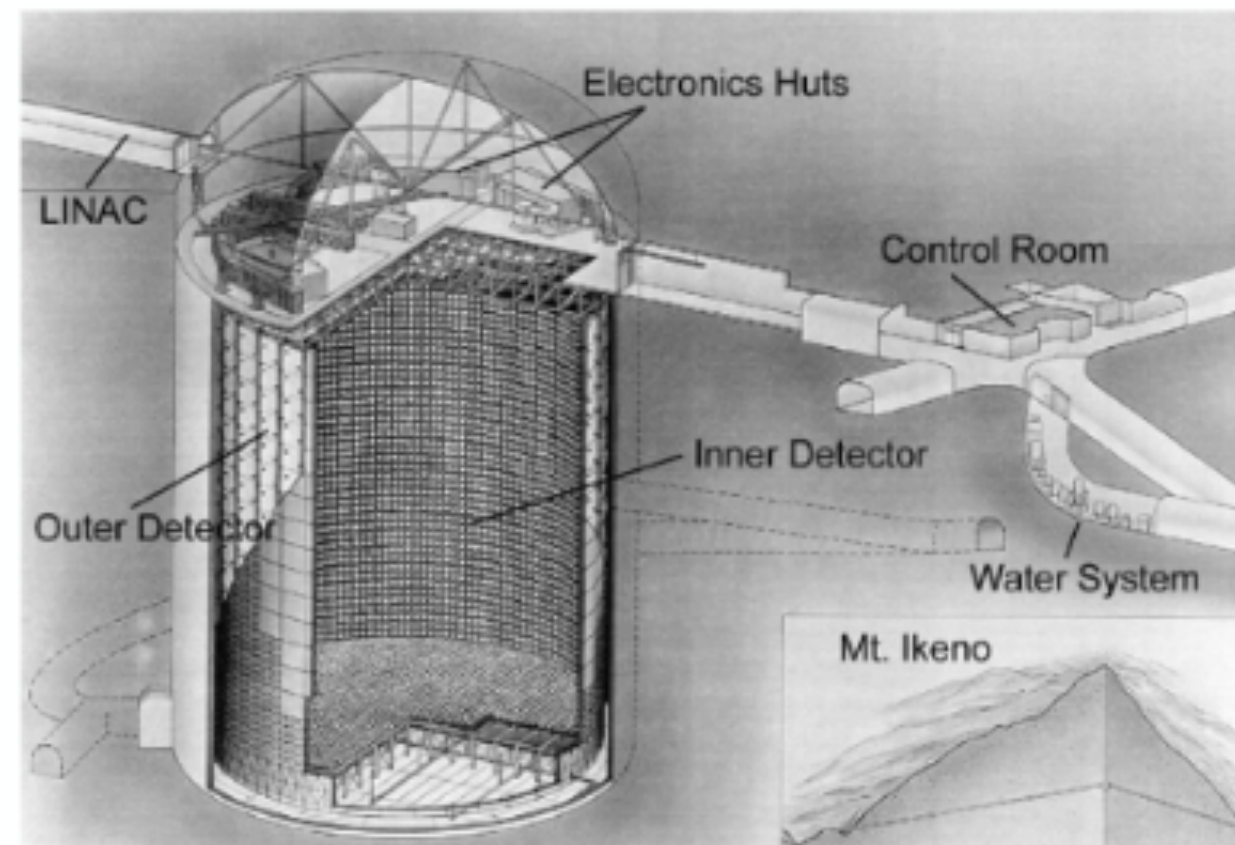

HK (2028-)
68m \varnothing x 71m tall
Fiducial mass: 188kton

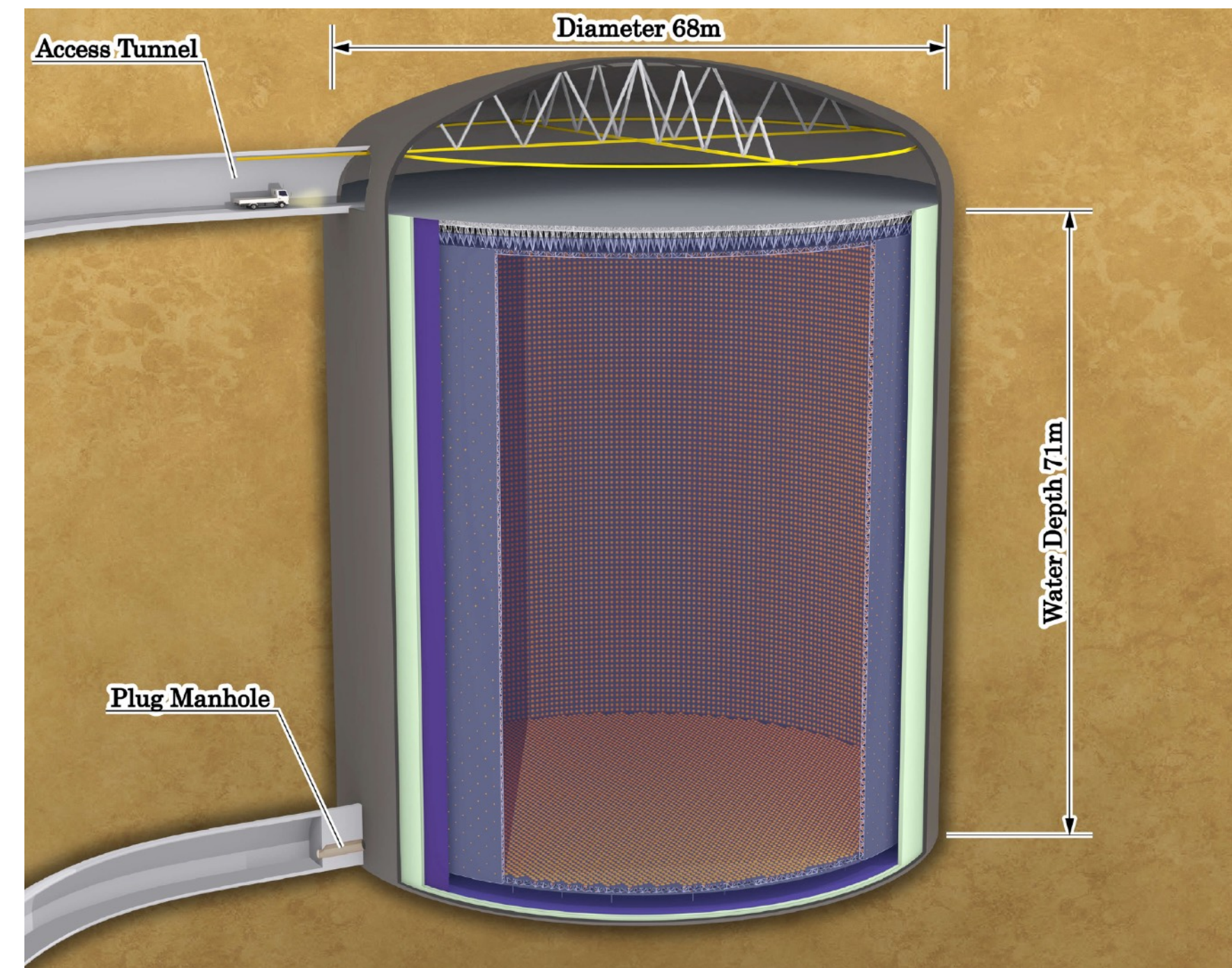

HK sensitivity to δ_{CP}

- HK will produce high statistics neutrino event samples and systematics errors become important
- $\nu_e/\bar{\nu}_e$ cross section has a big impact on this measurement
- Improved systematics are T2K systematics scaled based on ND280-upgrade and IWCD sensitivity
- If $\delta_{CP}=-\pi/2$ and normal ordering (favoured by T2K result), $\delta_{CP}=0$ can be excluded @ 5σ in 2~3 years
- If normal ordering and assuming improved systematics: **> 5σ exclusion after 10 years for 60% of δ_{CP} values**

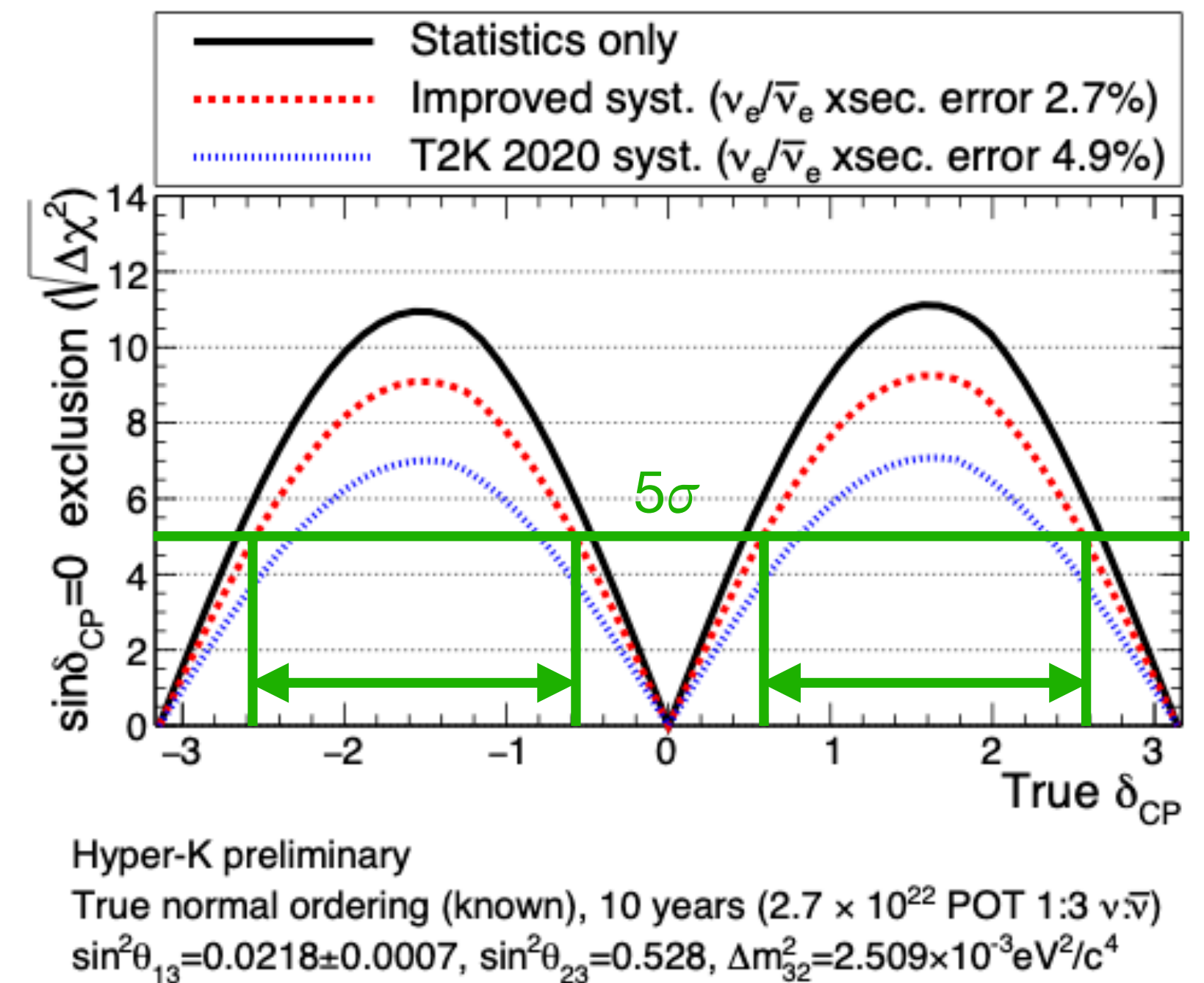
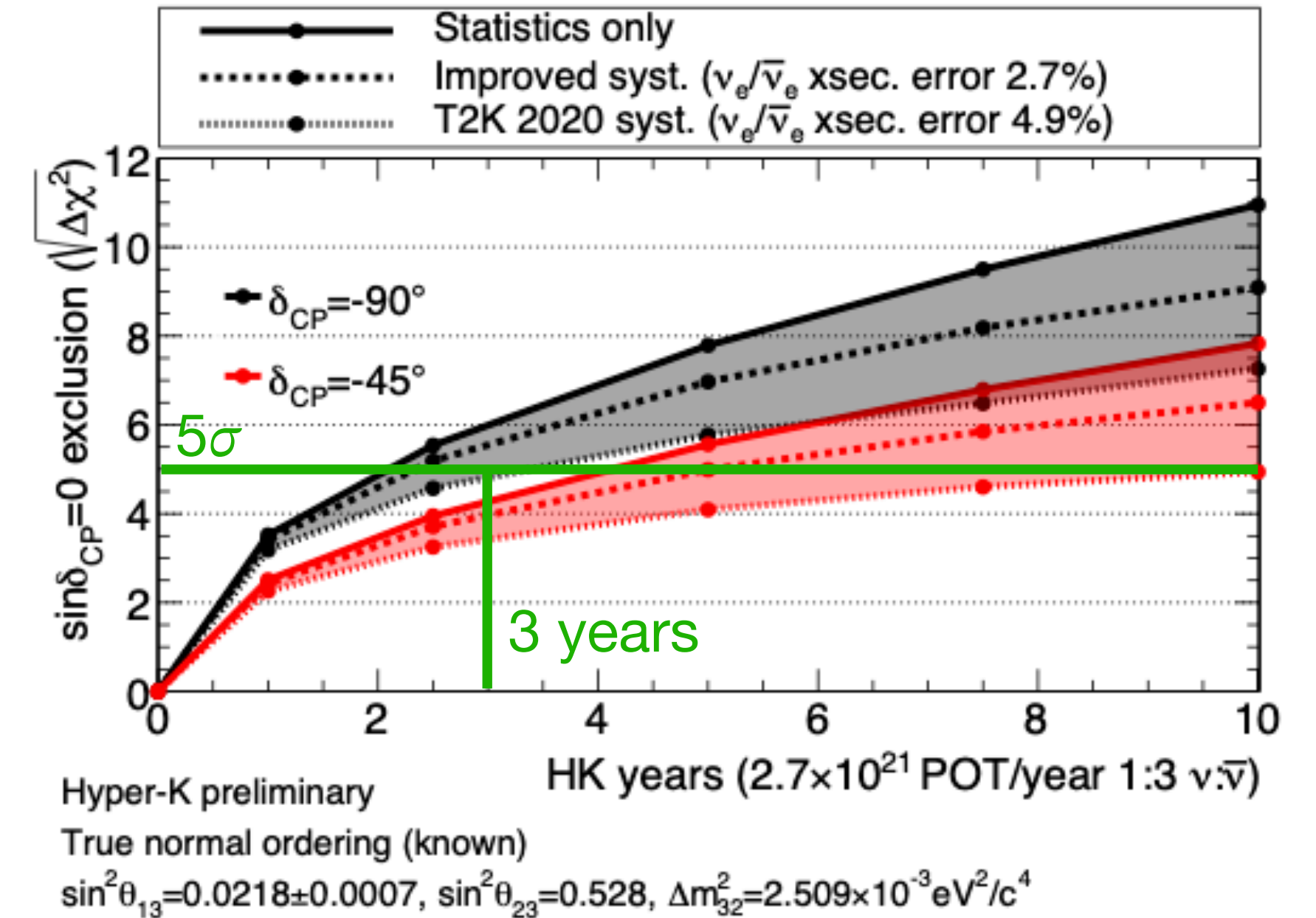

Proton decay

- Proton decay is predicted by grand unified theories (GUT) but hasn't been detected yet
- World-leading sensitivity for proton decay searches thanks to HK large mass
- 3σ sensitivity after 10 years:
 - $\sim 6 \times 10^{34}$ years for $p \rightarrow e^+ + \pi^0$
 - $\sim 2 \times 10^{34}$ years for $p \rightarrow \nu + K^+$

Simulated $p \rightarrow e^+ + \pi^0$ candidate

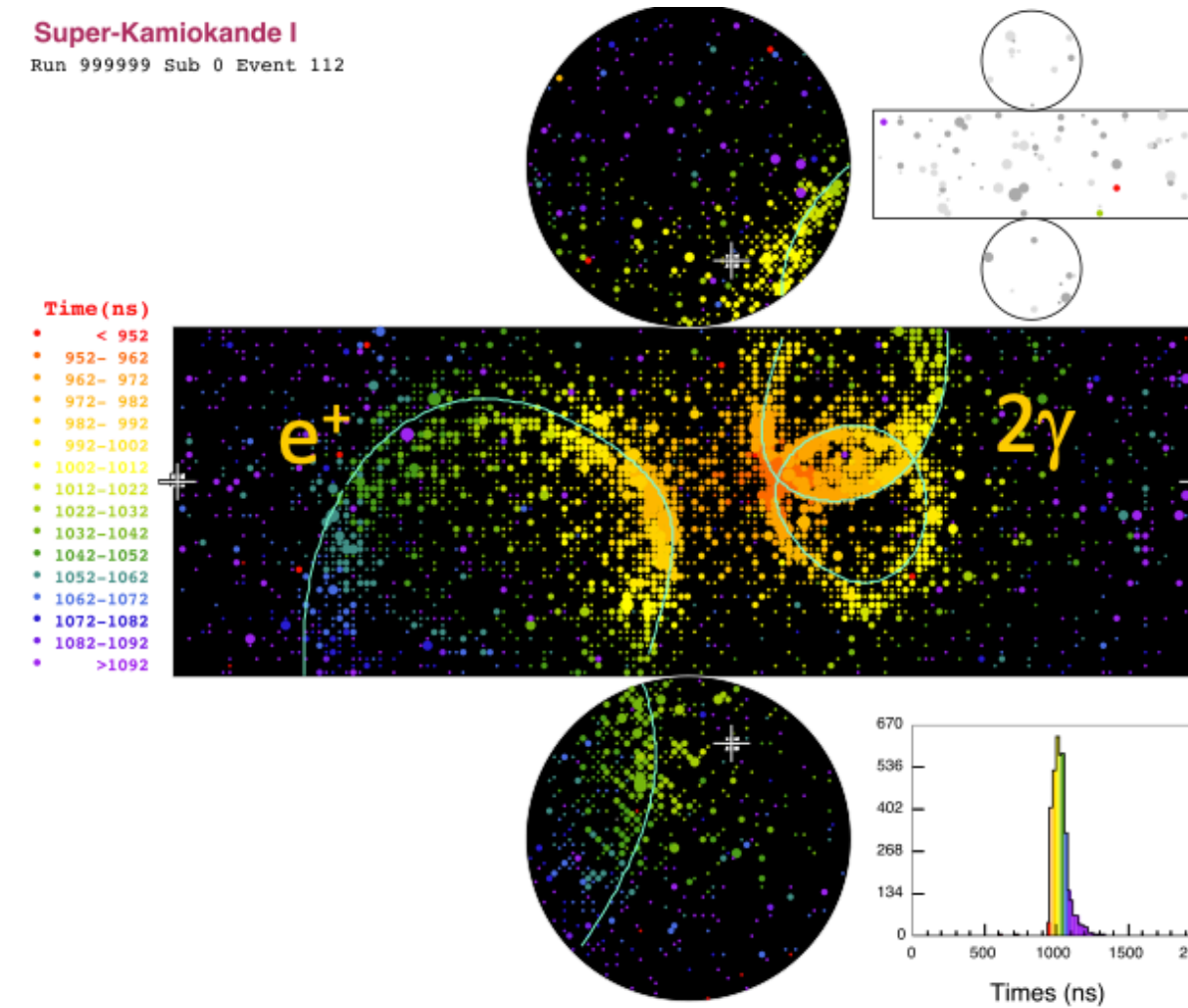

3σ discovery potential $p \rightarrow e^+ + \pi^0$

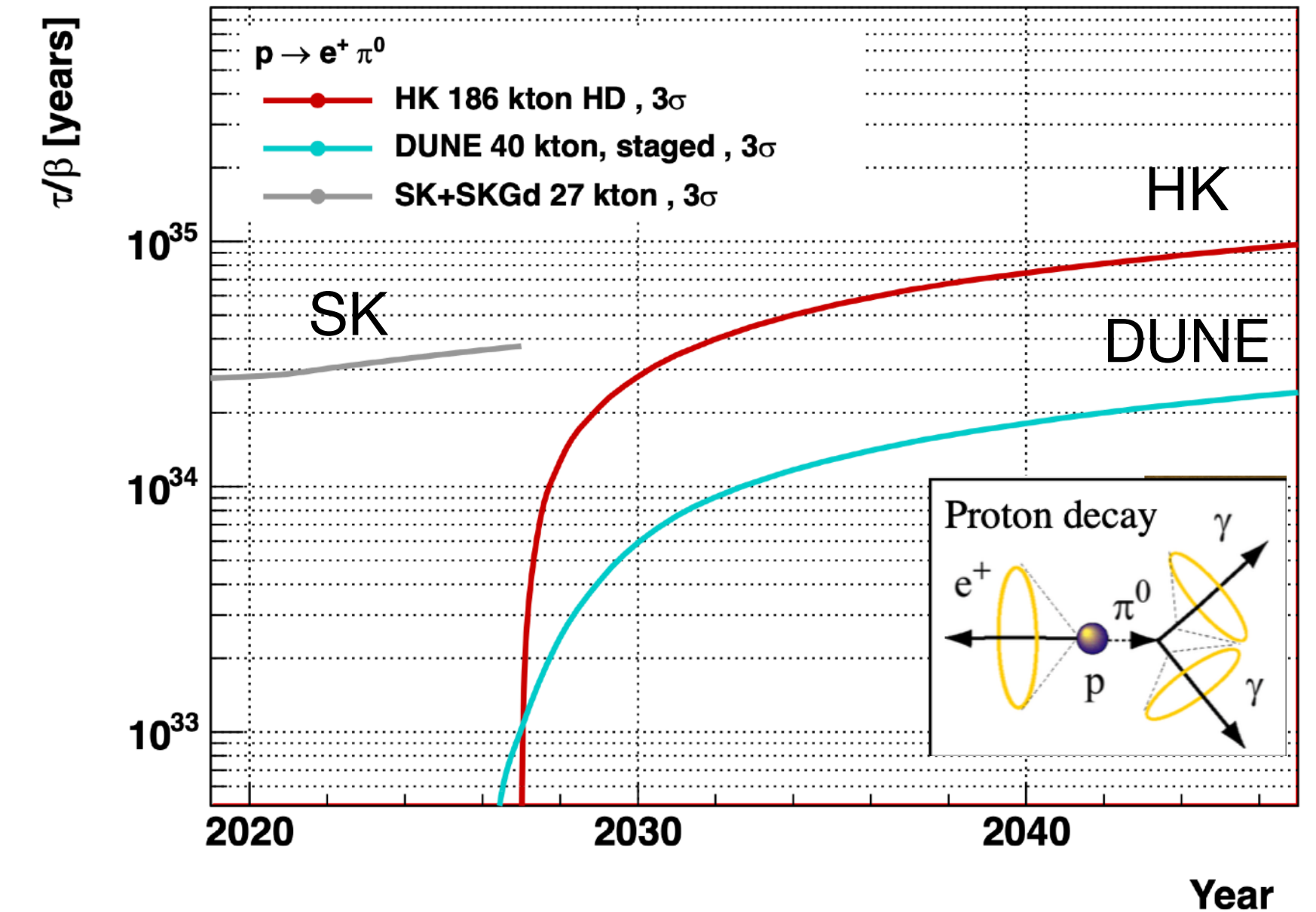

3σ discovery potential $p \rightarrow \nu + K^+$

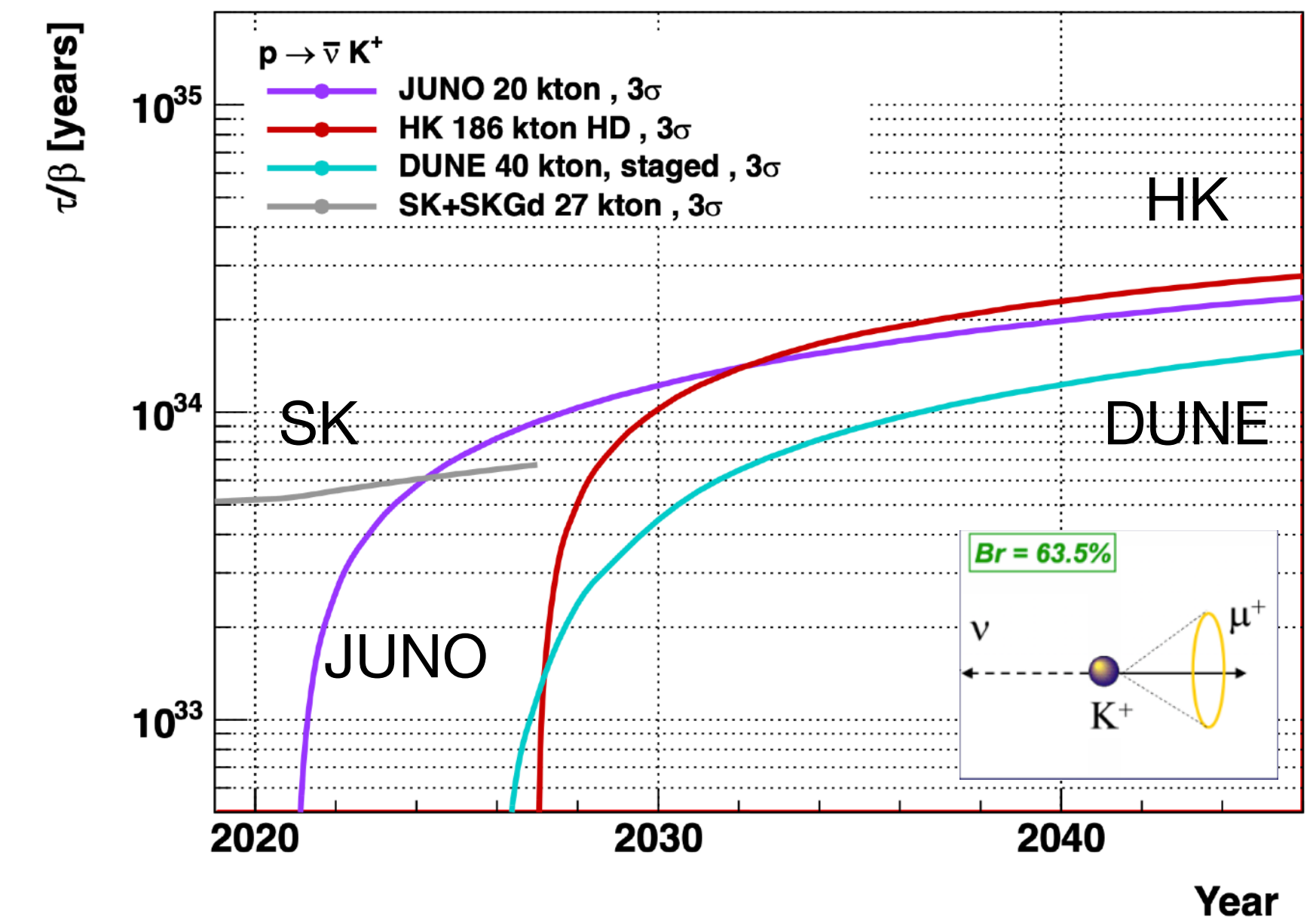

HK photosensors

- ~20k 20" PMTs
- Hamamatsu R12860 High QE
- 2x better performance than SK PMTs
- Purchase was completed and they are being tested
- + 800 mPMTs

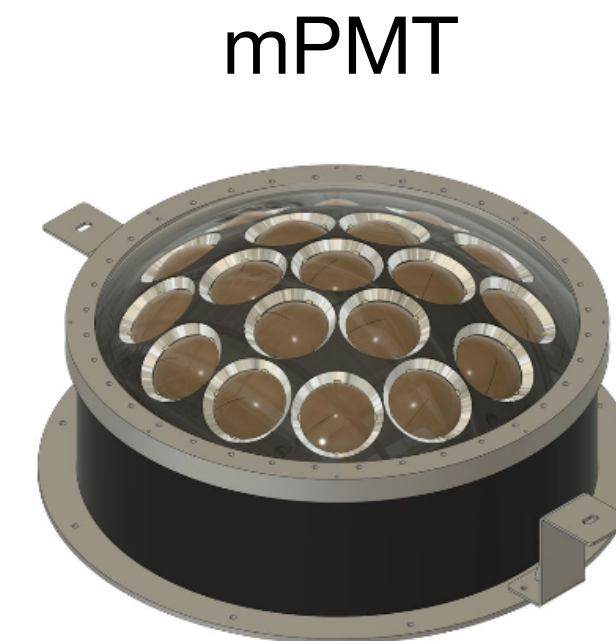
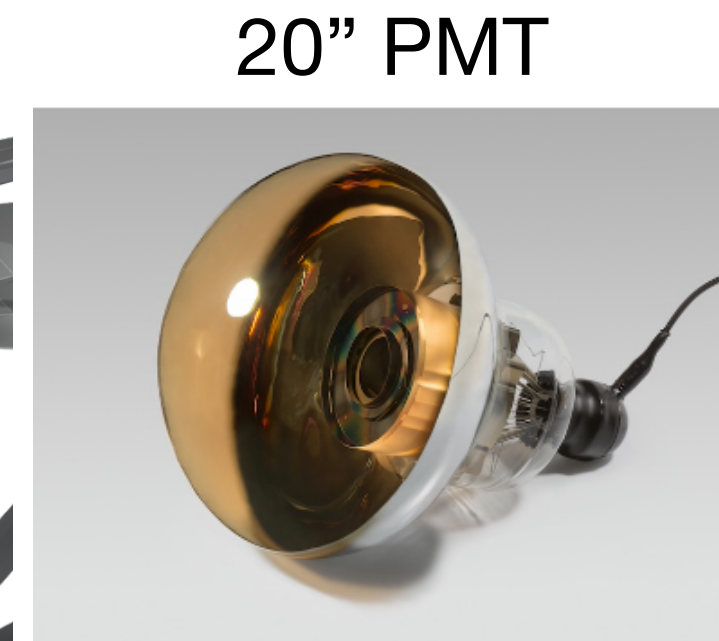
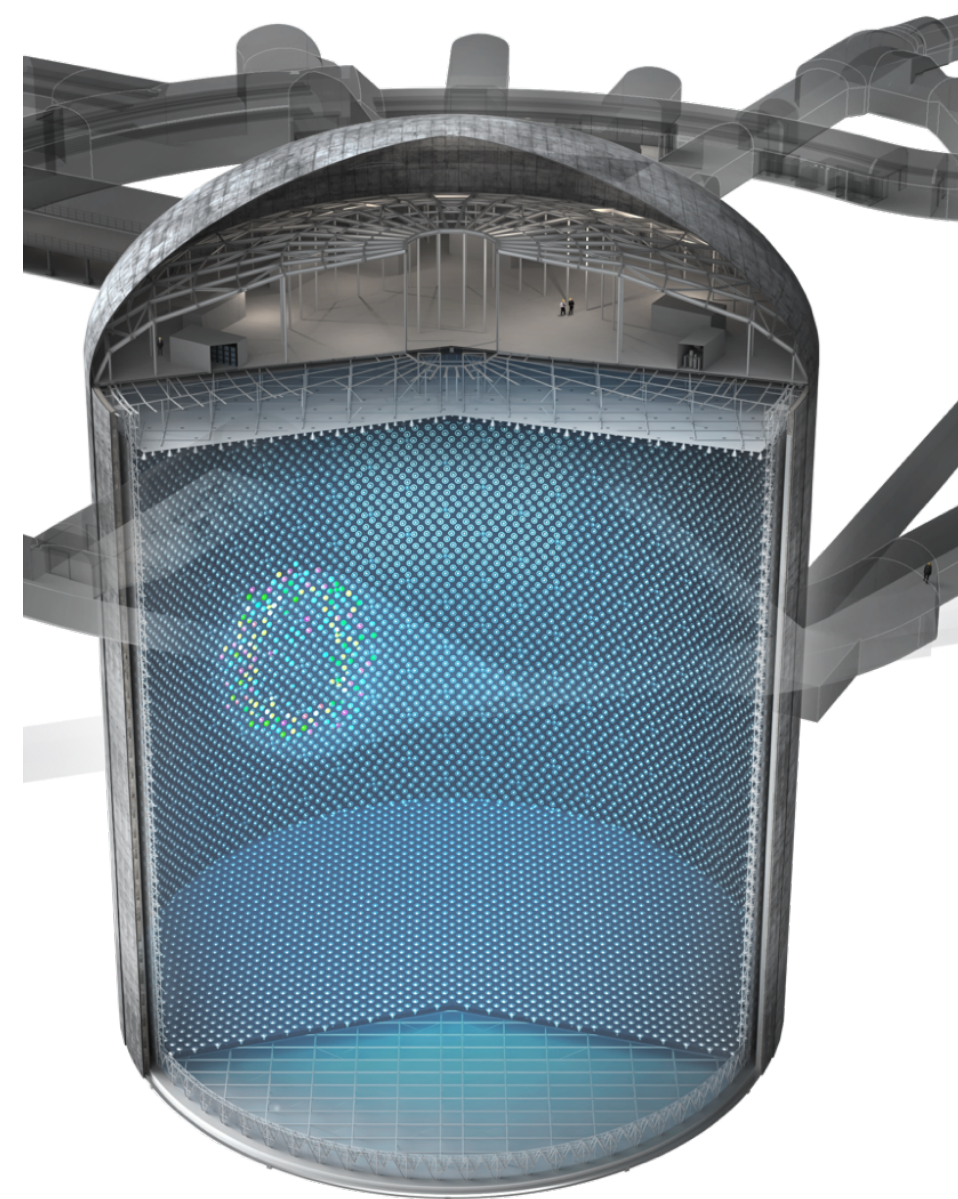

Mock-up to test installation procedures

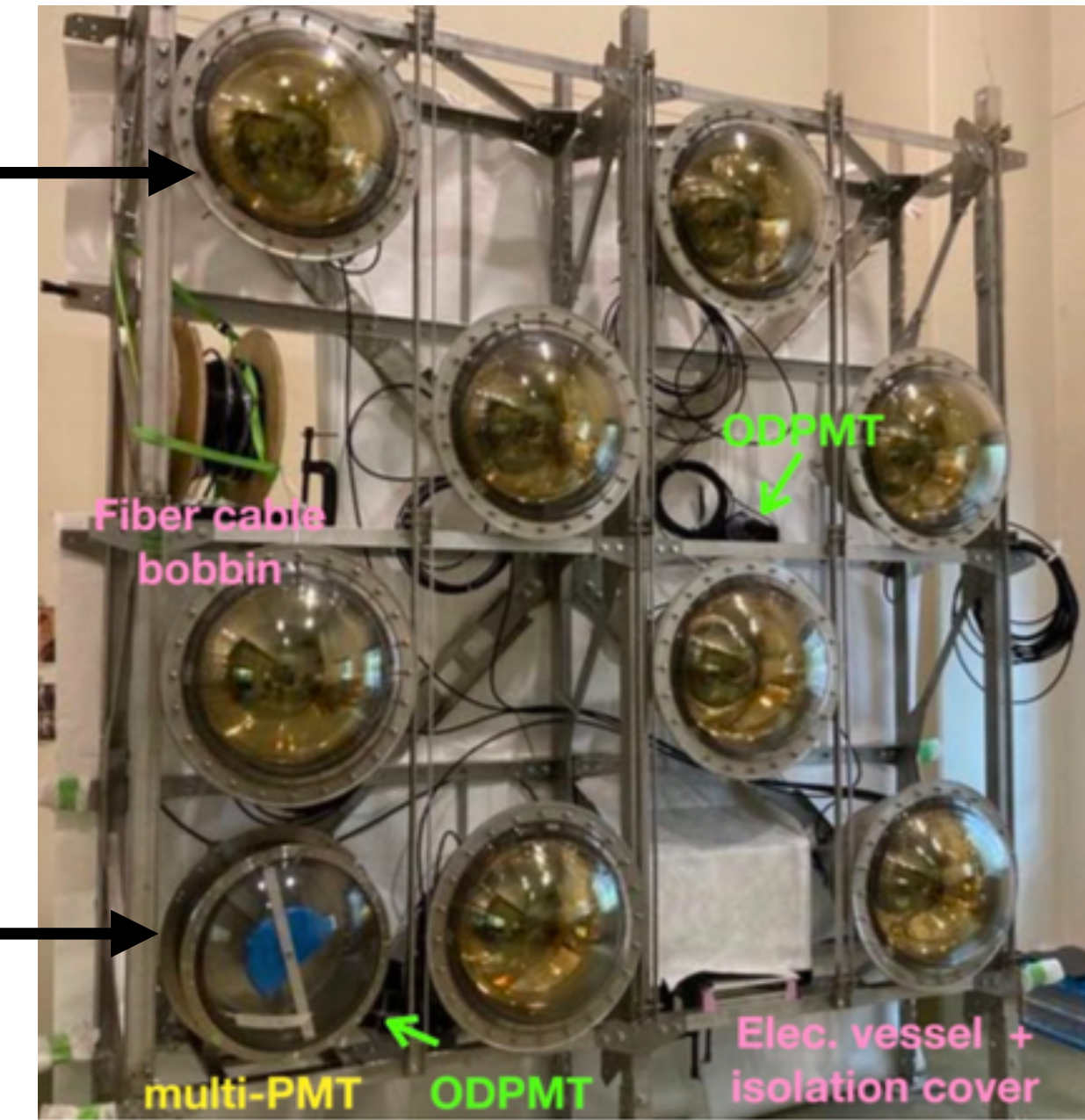

Hyper-K PMT
High Quantum Efficiency

Hamamatsu R12860
+2kV, 10^7 gain

Box & Line

Line

Box

High collection efficiency (CE)

Uniform path
→ High charge & time resolutions

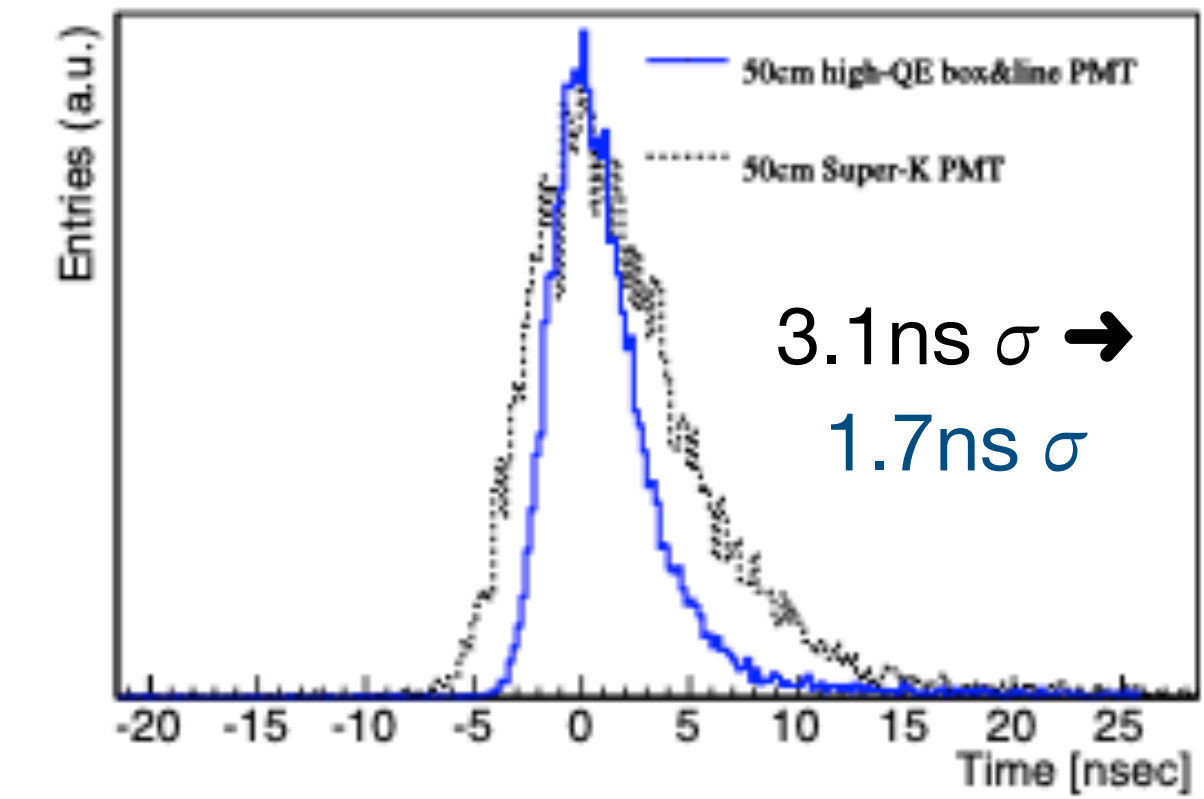
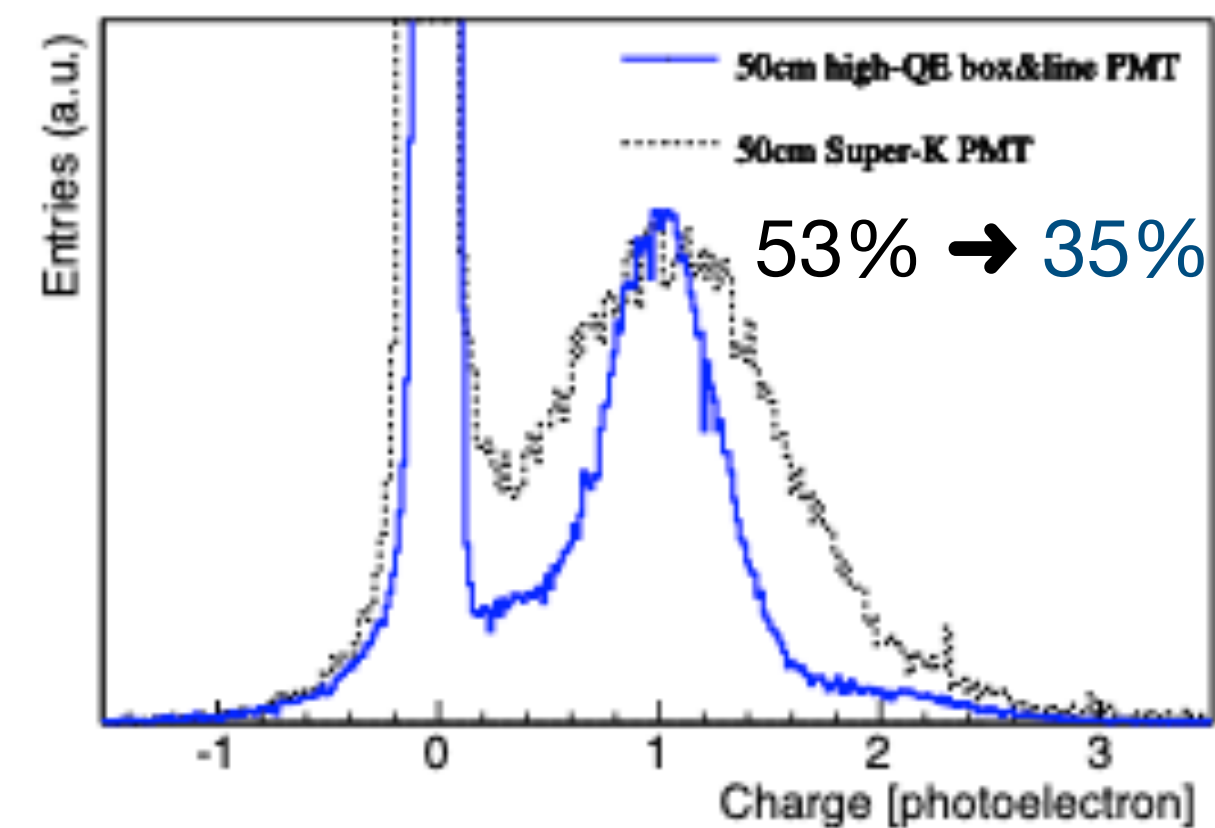
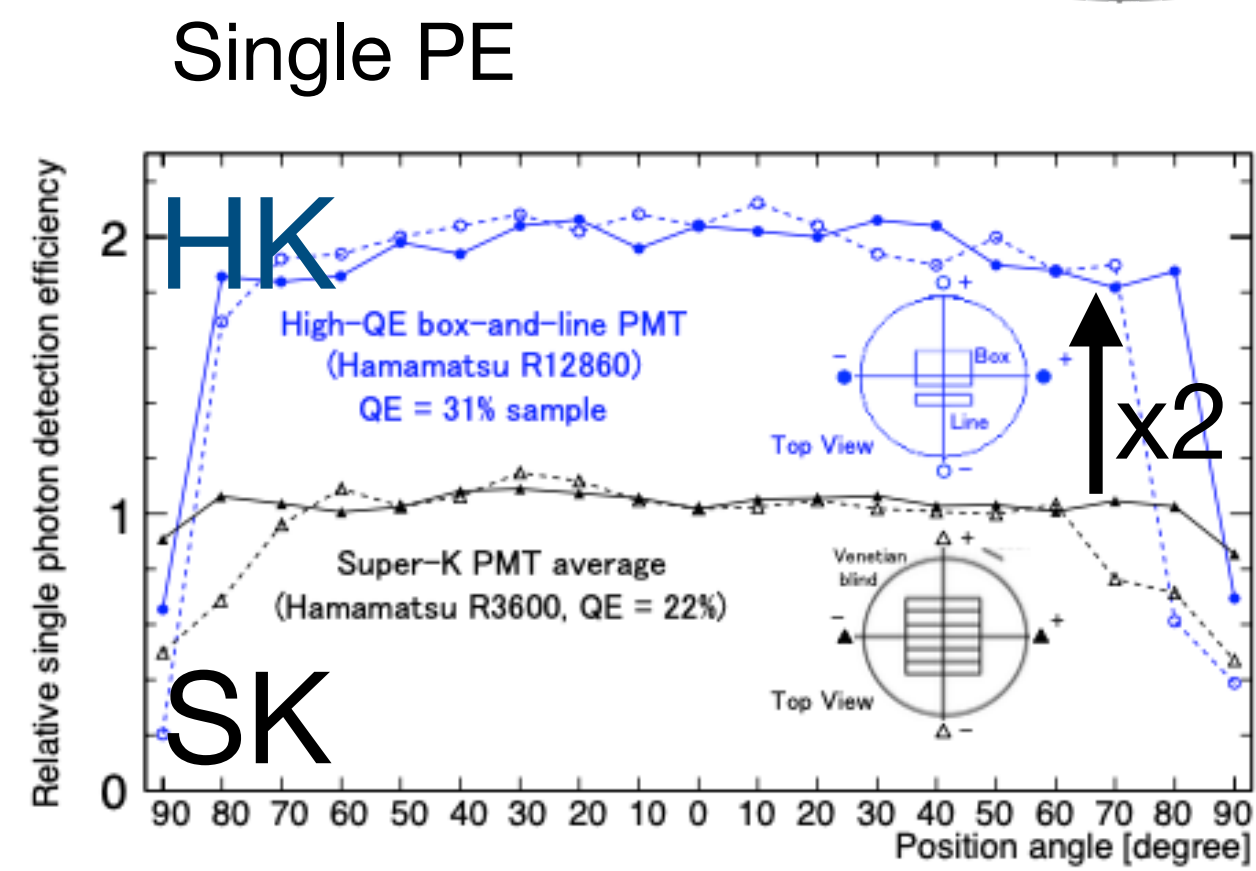

Multi-PMTs @ HK

- Modules consist of 19 3" PMTs
 - Provide higher granularity and photon directional information
 - Better timing resolution (0.6ns) and less sensitivity to residual magnetic fields compared to 20" PMTs
- Reference to characterize calibration light sources for neighbouring 20" PMT
- See Rob Collister's talk about mPMTs, (PPD) R2-1

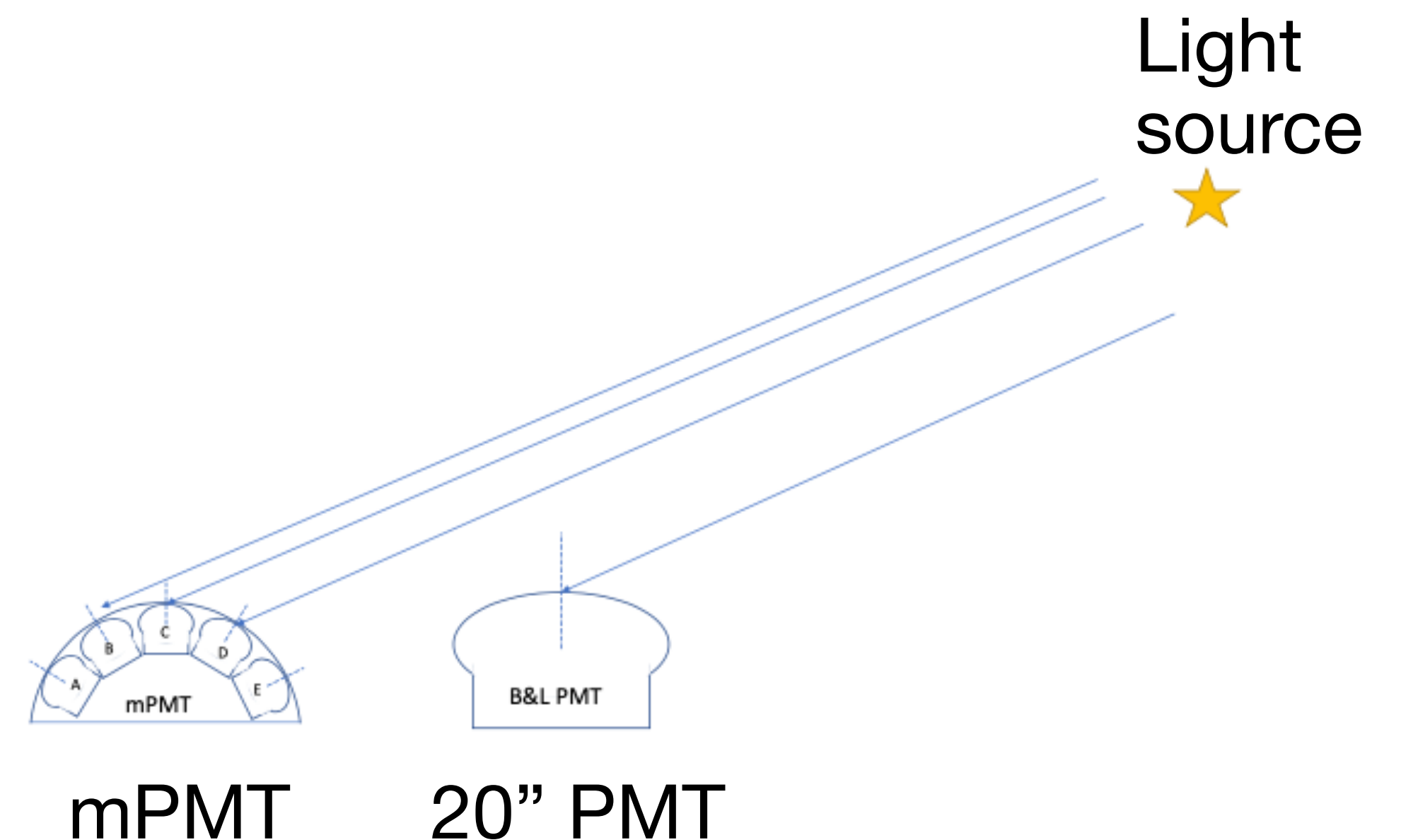
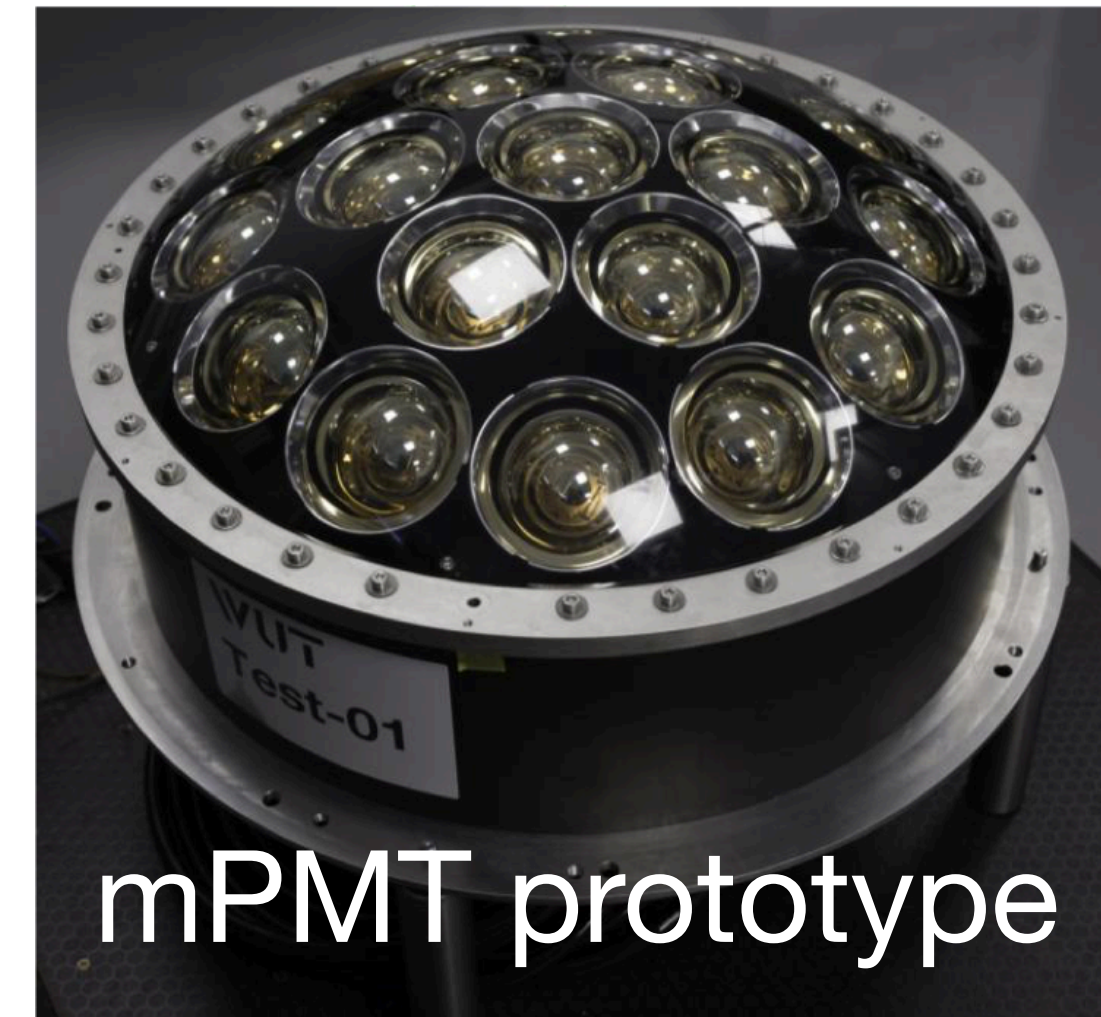

LED-mPMTs @ HK

Total mPMT: 808 = 552 barrel + 128 TOP + 128 BOTTOM

LED-mPMT: 200 = 168 barrel + 16 TOP + 16 BOTTOM

- 200 LED-mPMT with 5 3" PMT replaced by 5 LED modules to allow in-situ calibrations in Hyper-K
 - Water quality monitoring (light attenuation and scattering in water)
 - PMT angular response
- See Polina Sukhova's talk about PMT calibration using diffused light, (PPD) T1-8

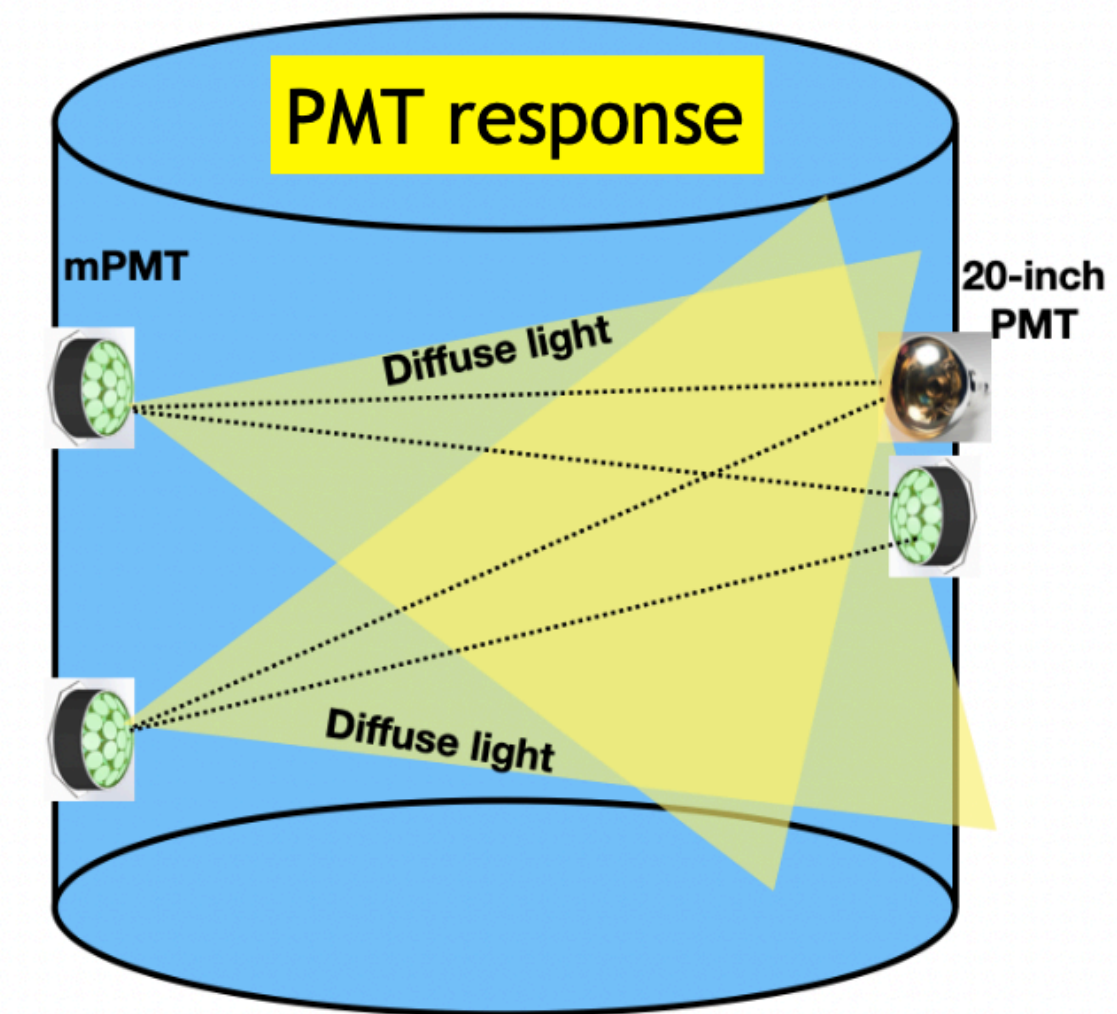
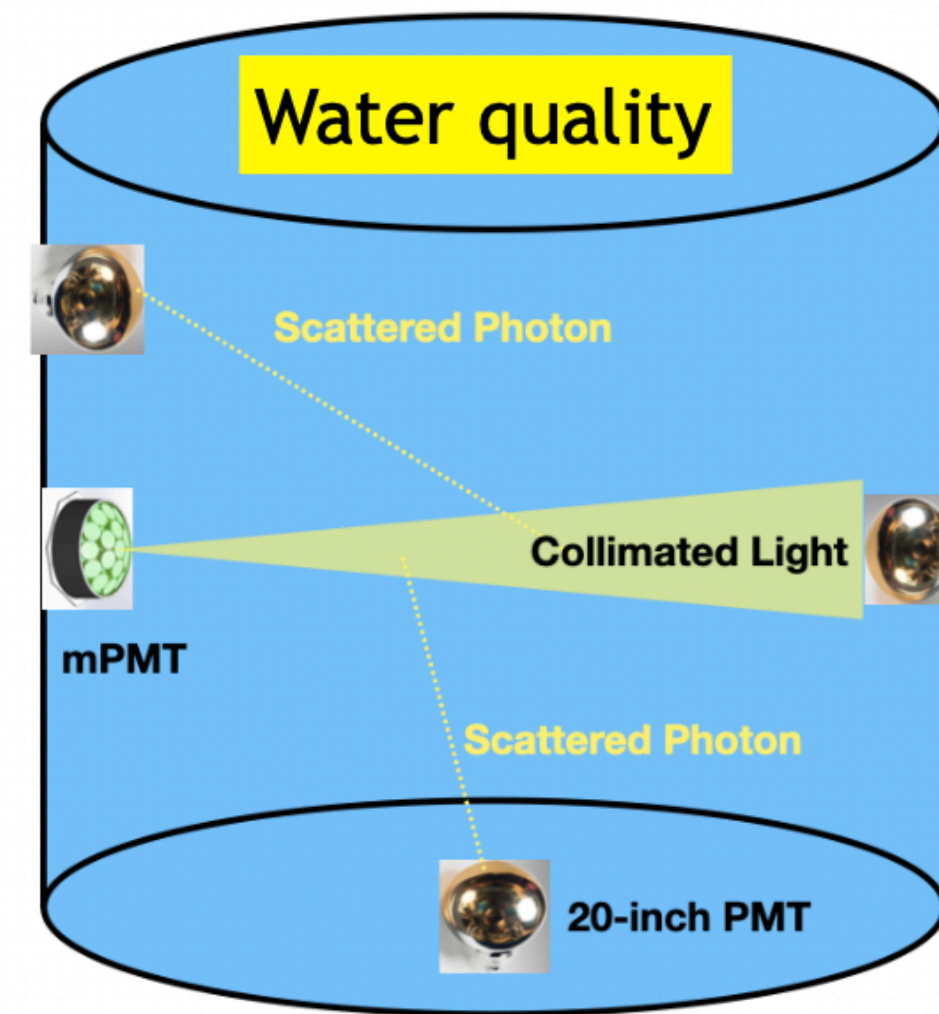

LED-mPMT prototype
@ Carleton University

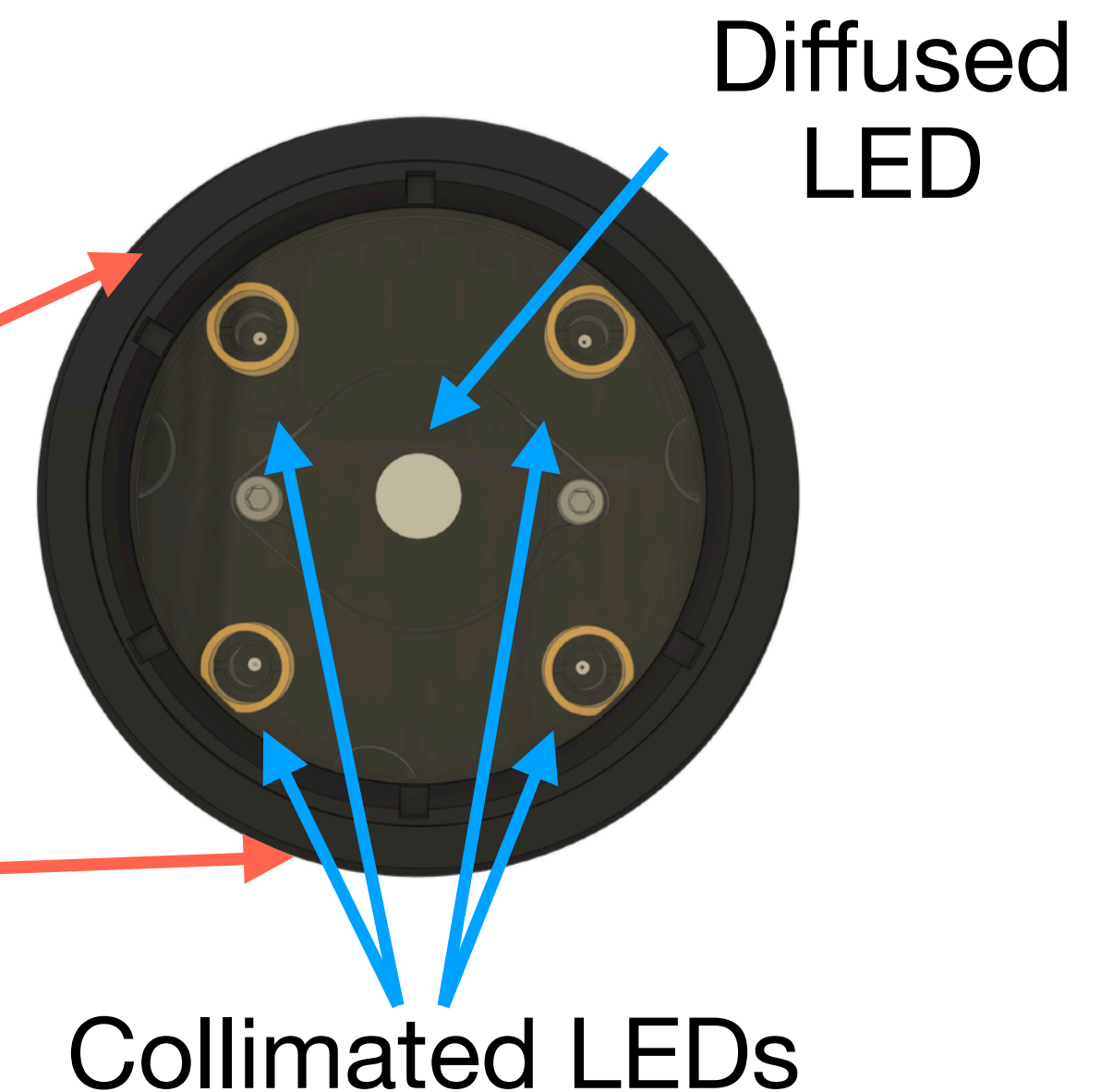
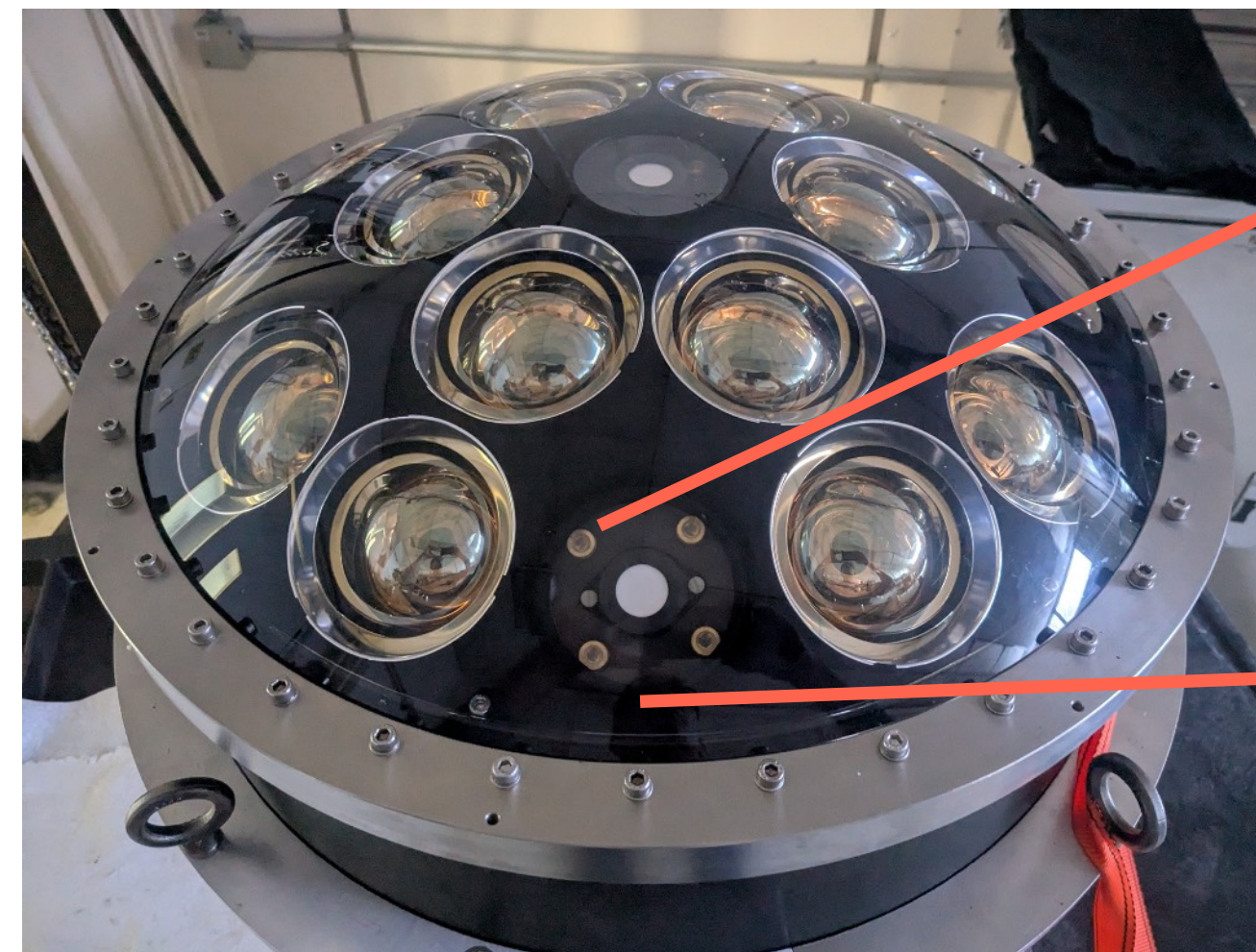

More Canadian contributions



- University of Winnipeg's photogrammetry system for WCTE, IWCD and HK
 - Measure detector geometry and calibration source position using stereoscopic reconstruction with photographs
- TRIUMF's water monitor system for WCTE, IWCD and HK
 - Measures the relative transmission of a continuous flow of sample water along a 8.5m long pipe with pulsed 235-450nm collimated light and PMTs

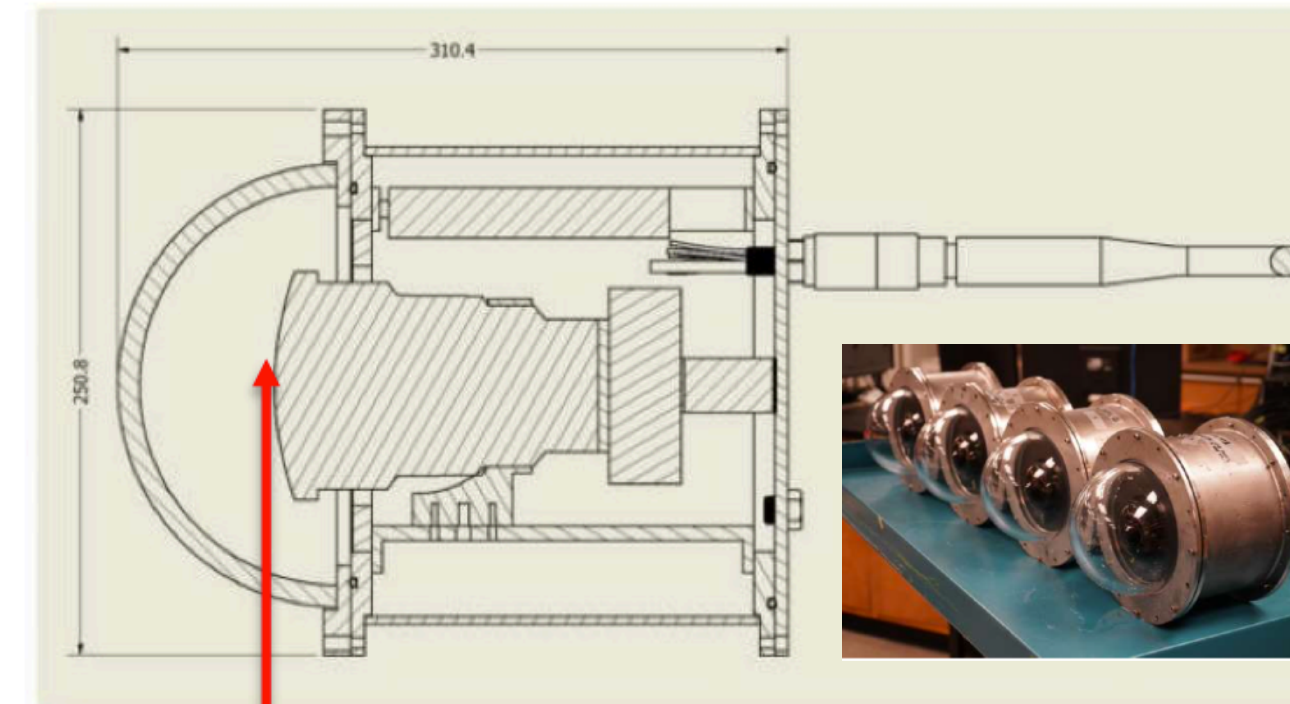

Photogrammetry System x8 (center of the hemisphere)

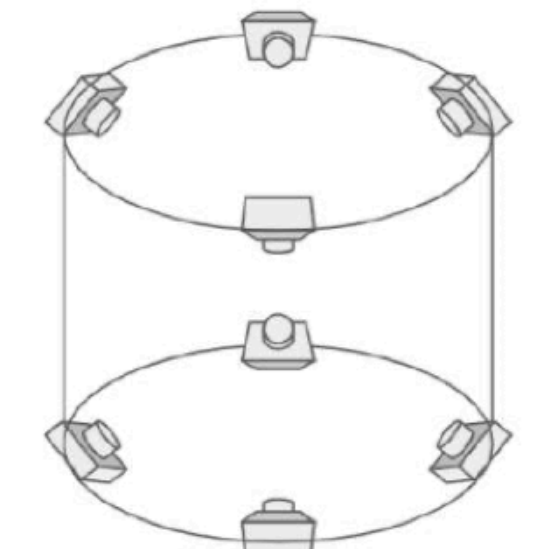
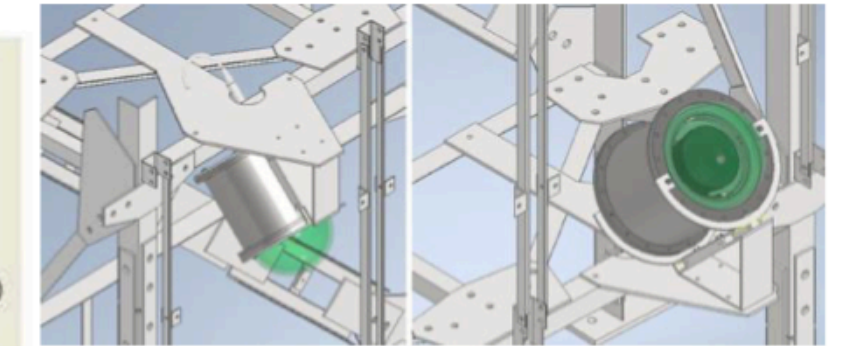

8 cameras config A

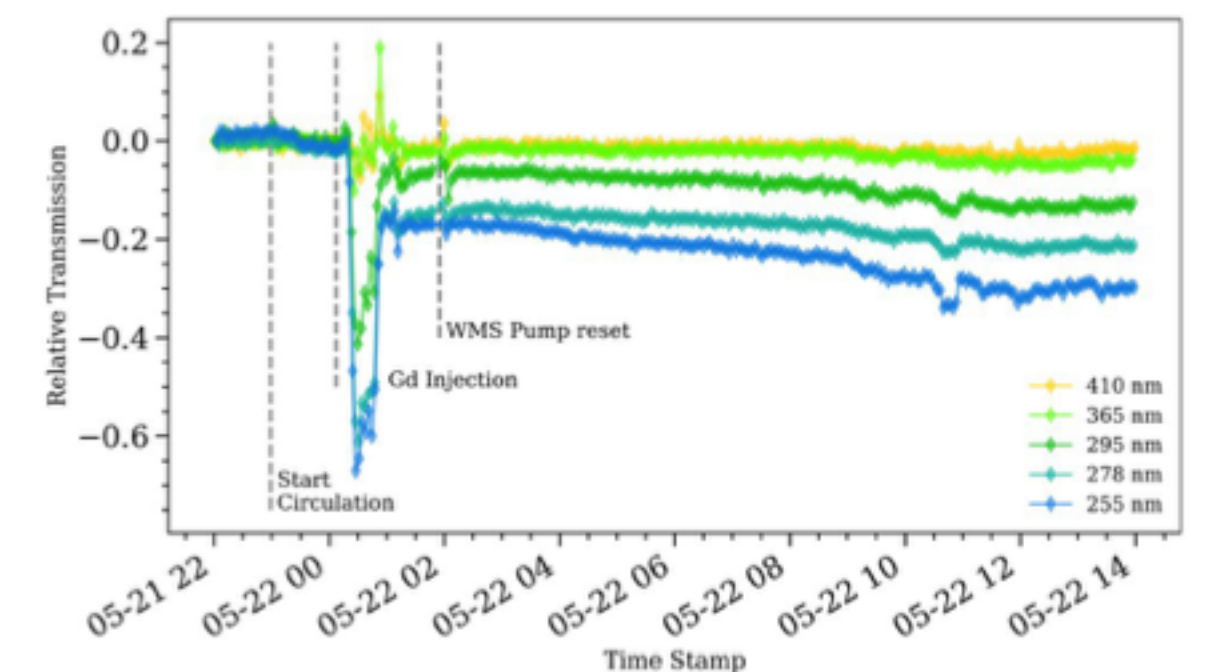
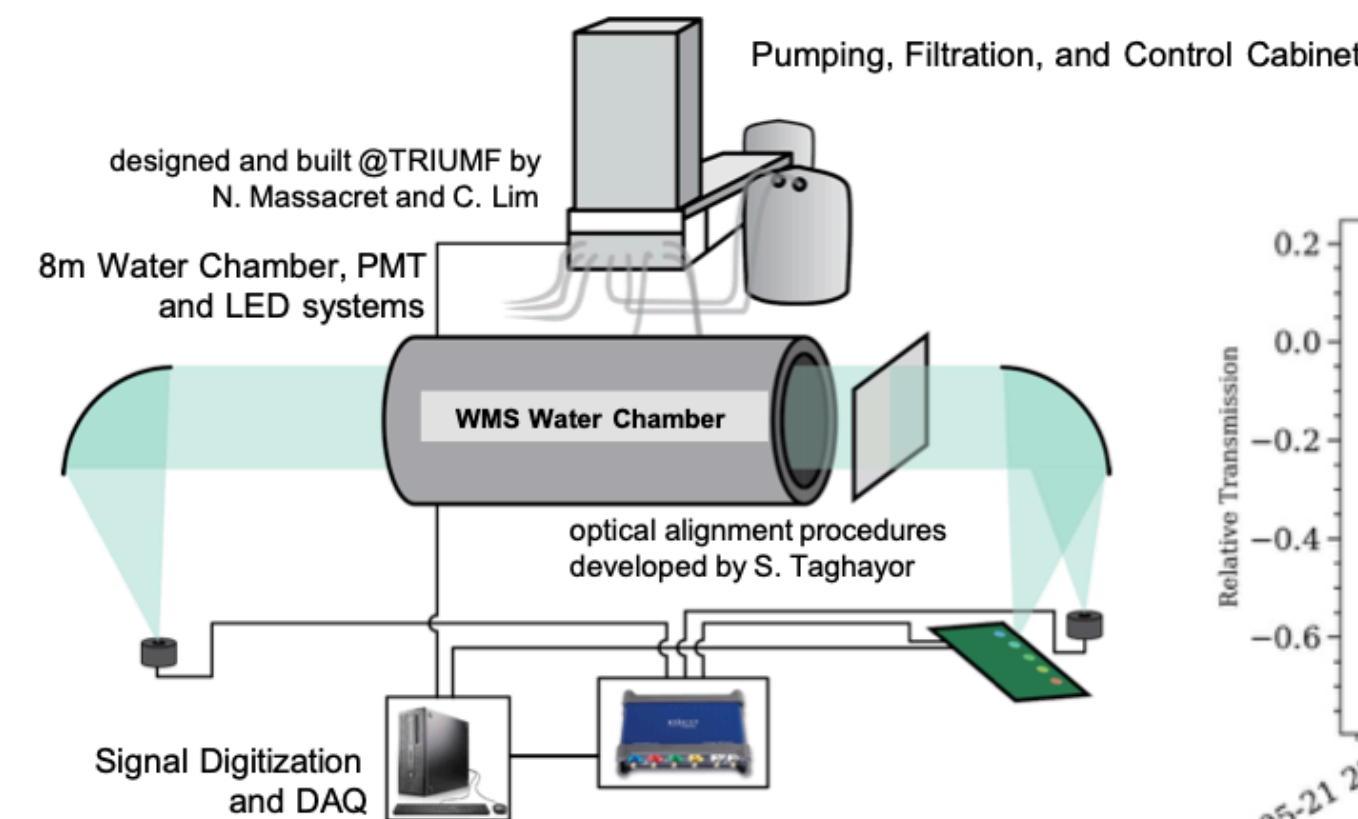

Cavern excavation

- “World’s largest single human-made cavern” completed in July 2025
- Major engineering milestone recognized
 - The 100th MMIJ (Mining and Materials Processing Institute of Japan) Watanabe Award
 - The JGS (Japan Geotechnical Society) Technical Achievement Award 2025
 - The JSCE (Japan Society of Civil Engineers) Outstanding Civil Engineering Achievement Award 2025



Main HK cavern (2025/7/31)

Y. Asaoka et.al., Prog. Theor. Exp. Phys 2026, ptag091



Cavern construction status

- Construction of the tank side walls of the water tank is progressing on schedule

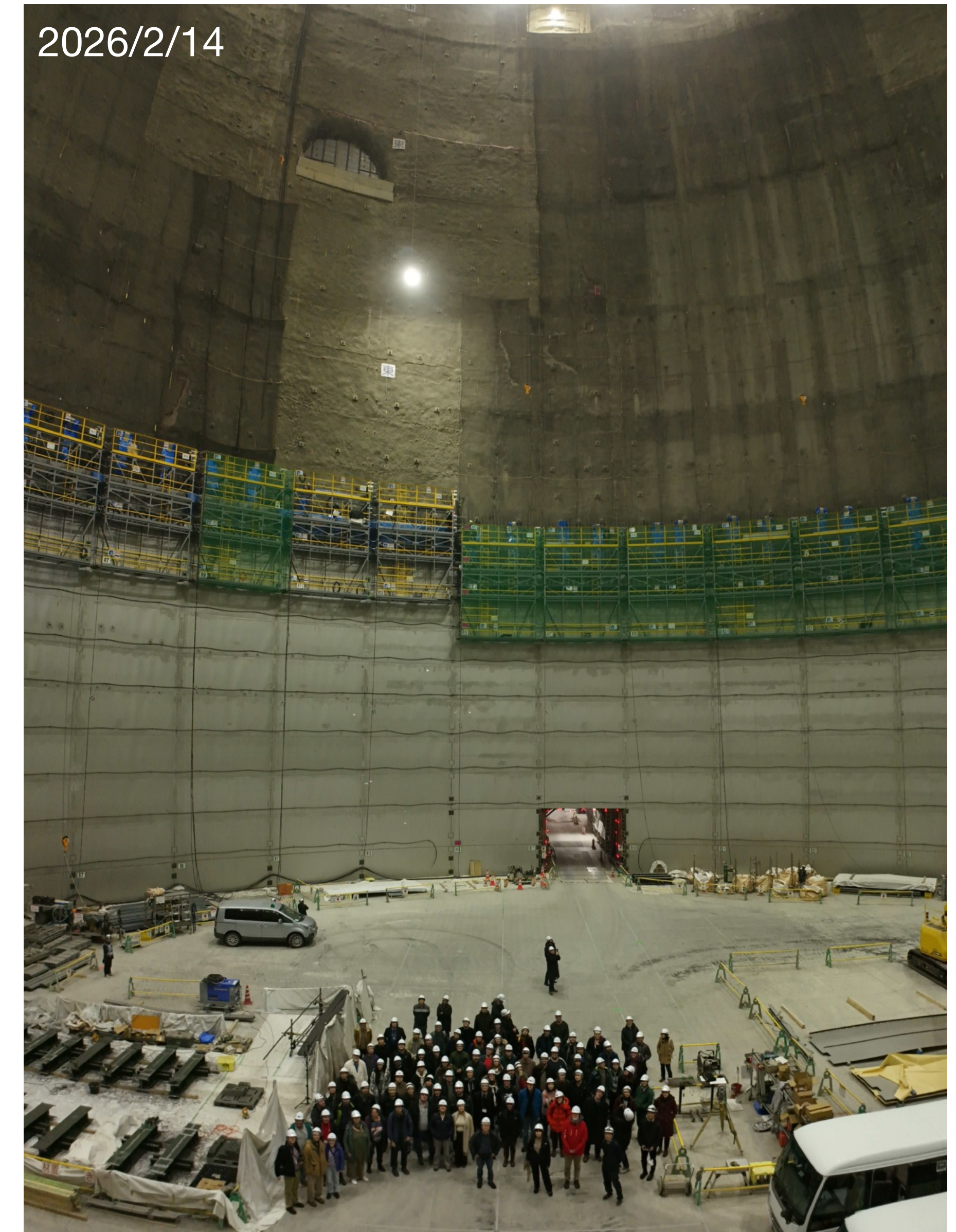
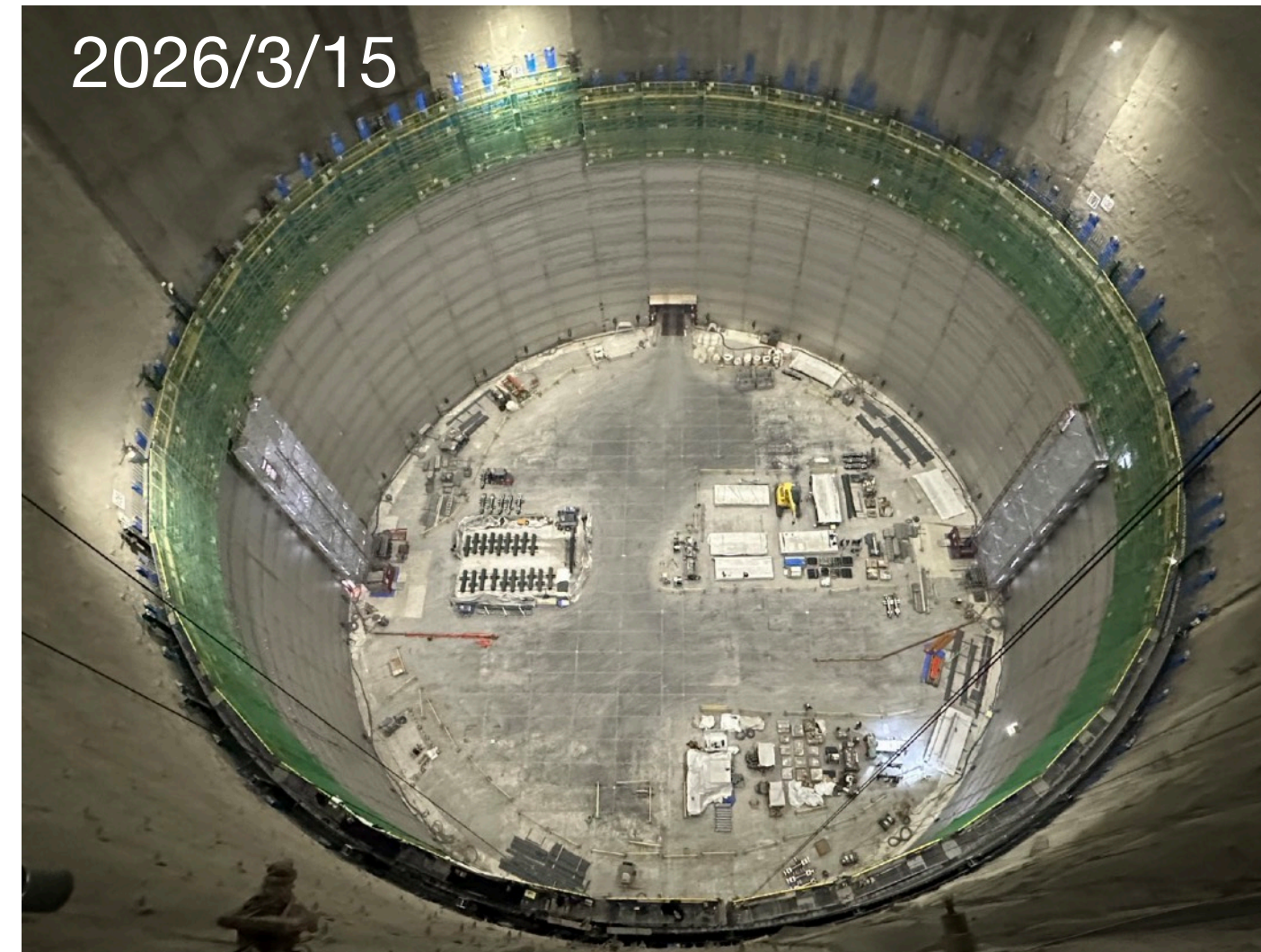

2026/5/24

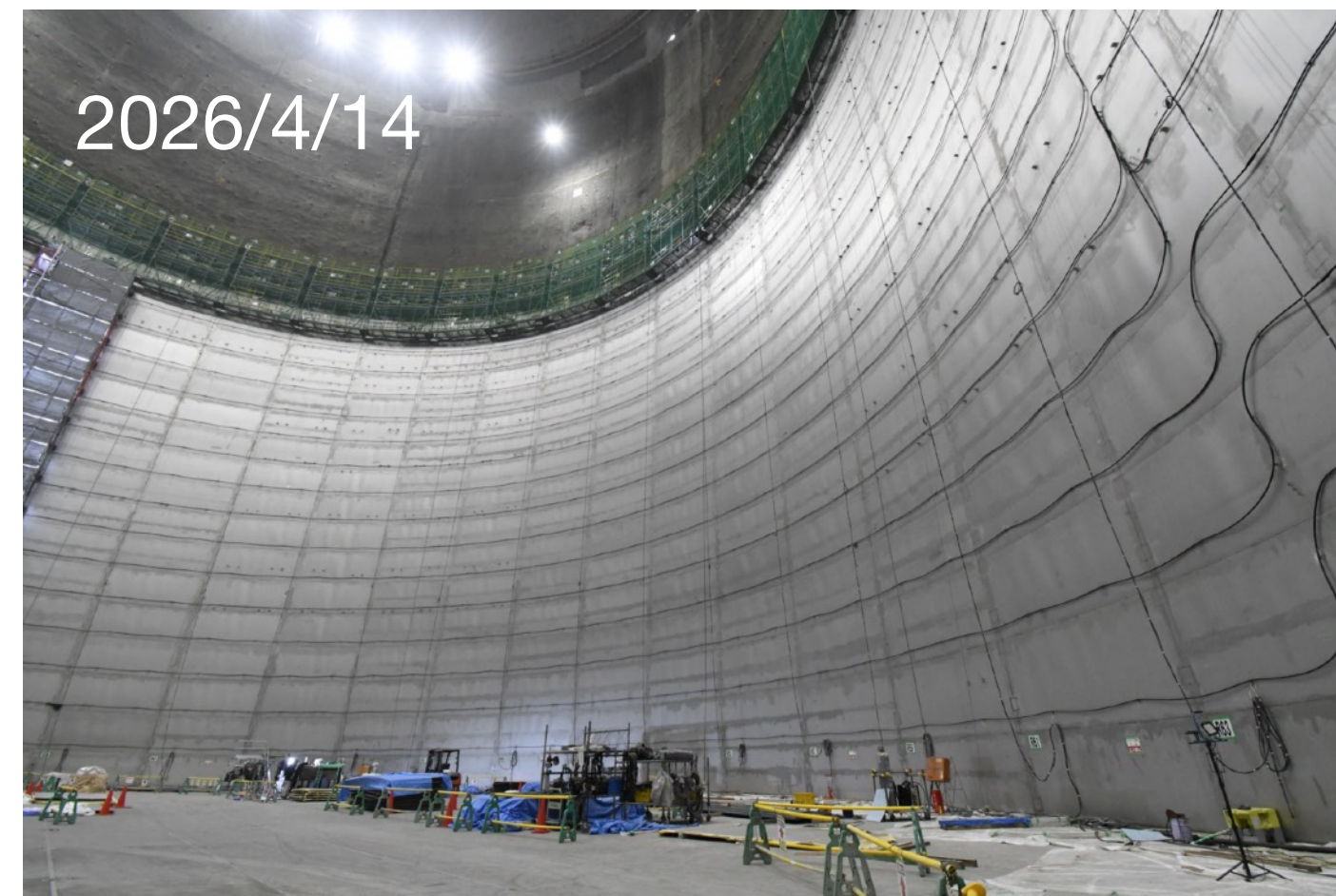

Hyper-K timeline

- Construction started in 2020
- Assembly and installation of photosensors starting in next year
 - Collaborators getting ready for construction shifts
- Neutrino beam power upgrades and IWCD construction are ongoing
- Operations scheduled to start in JYP 2028

JFY (Japanese Fiscal Year) starts in April

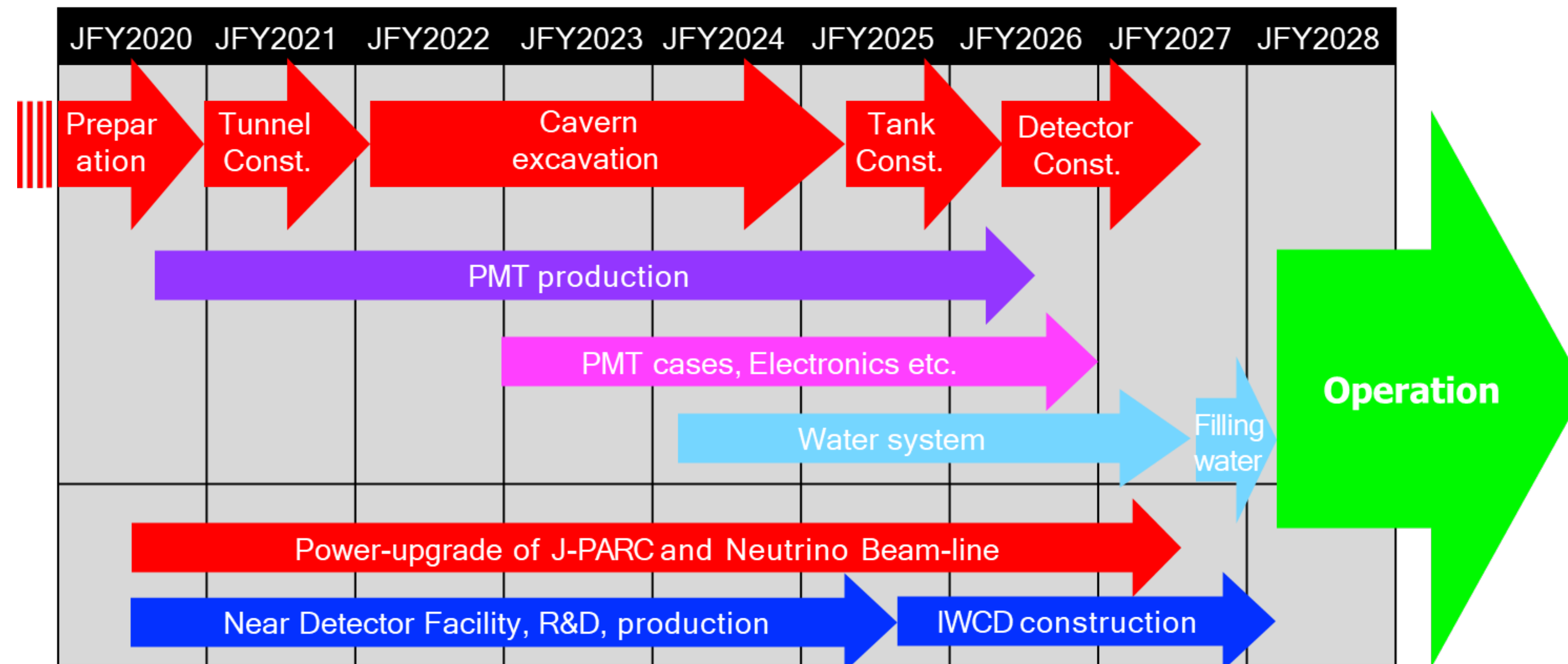

Conclusions

- HK has a very exciting and wide physics program
 - Unprecedented sensitivity to CP violation
 - World best limit for proton decay
- High statistics of neutrino events thanks to large fiducial mass and high power neutrino beam provided by J-PARC
- Important contributions proposed and led by Canada
 - OTR monitor, IWCD, WCTE, LED-mPMT, photogrammetry, water monitor systems
- Operation expected to start in 2028

Backup

Water Cherenkov detection principle

SK

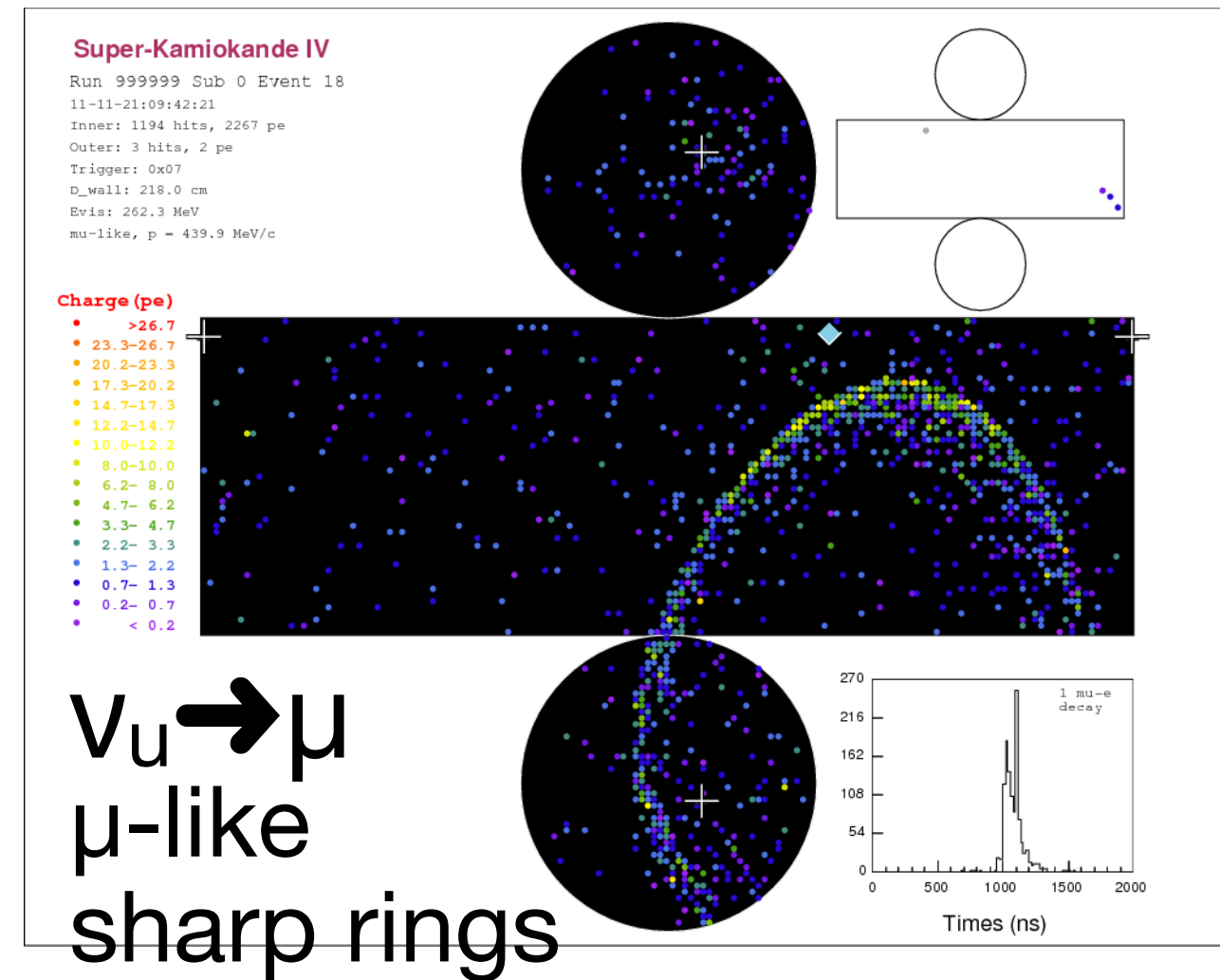
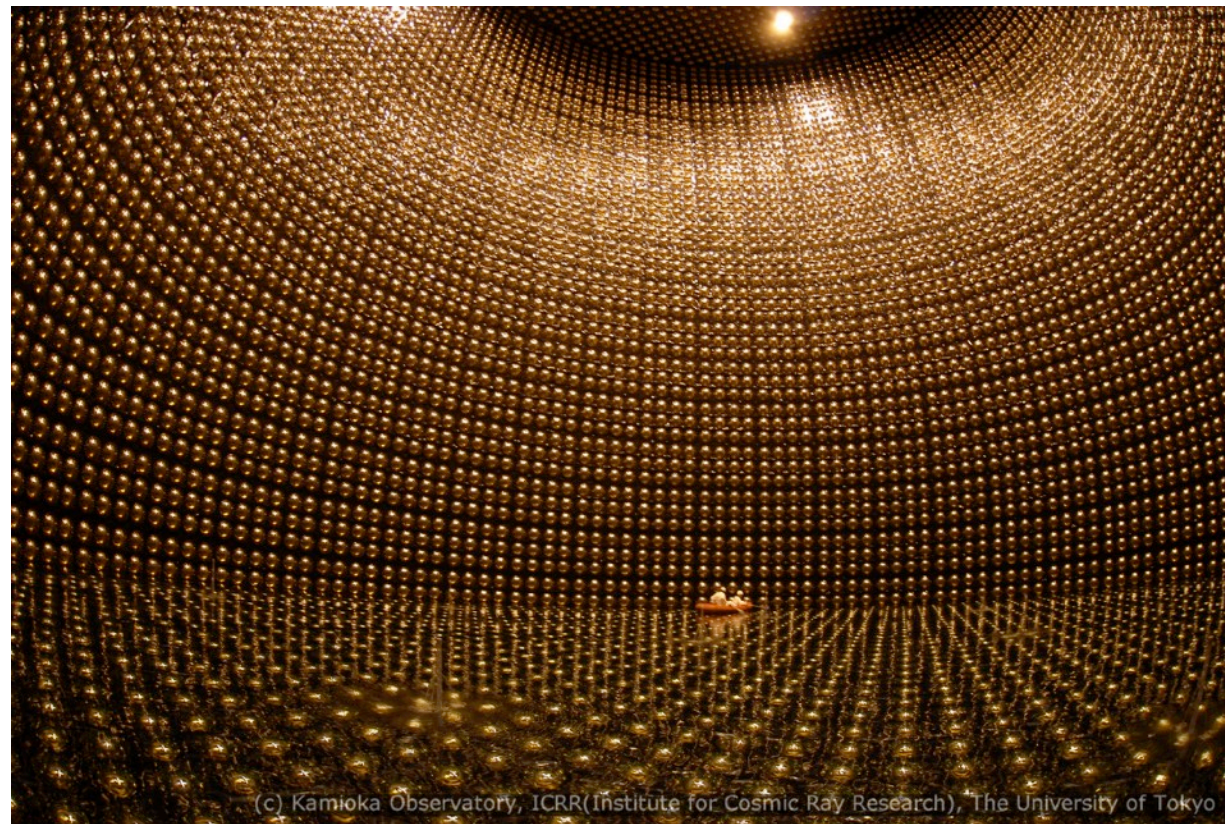

- Water Cherenkov detectors (WCTE, IWCD, SK, HK) use the Cherenkov ring pattern to identify charge particles
- Charged particles (μ^\pm and e^\pm) can be induced by neutrino (ν_μ and ν_e) interactions in the water

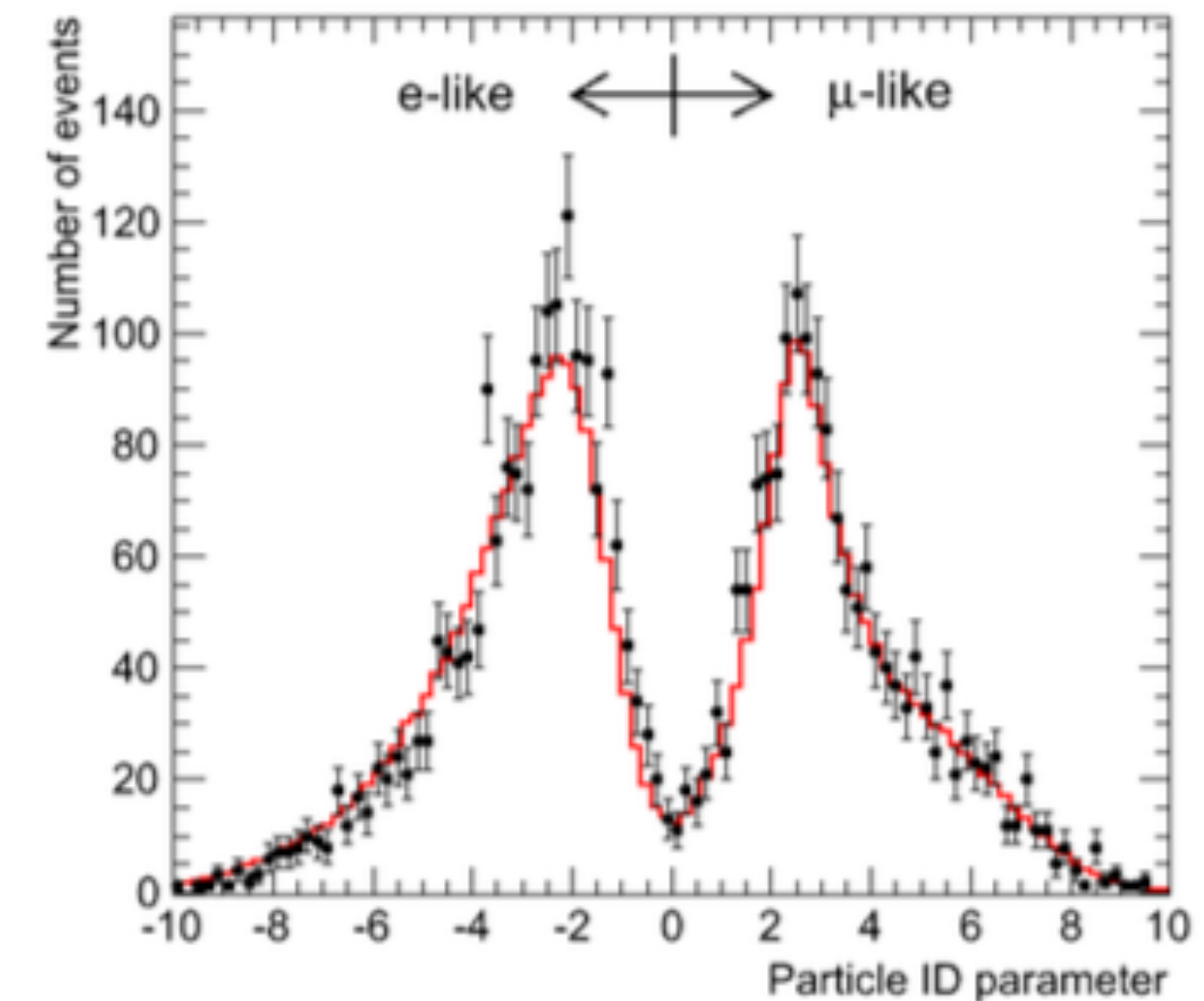
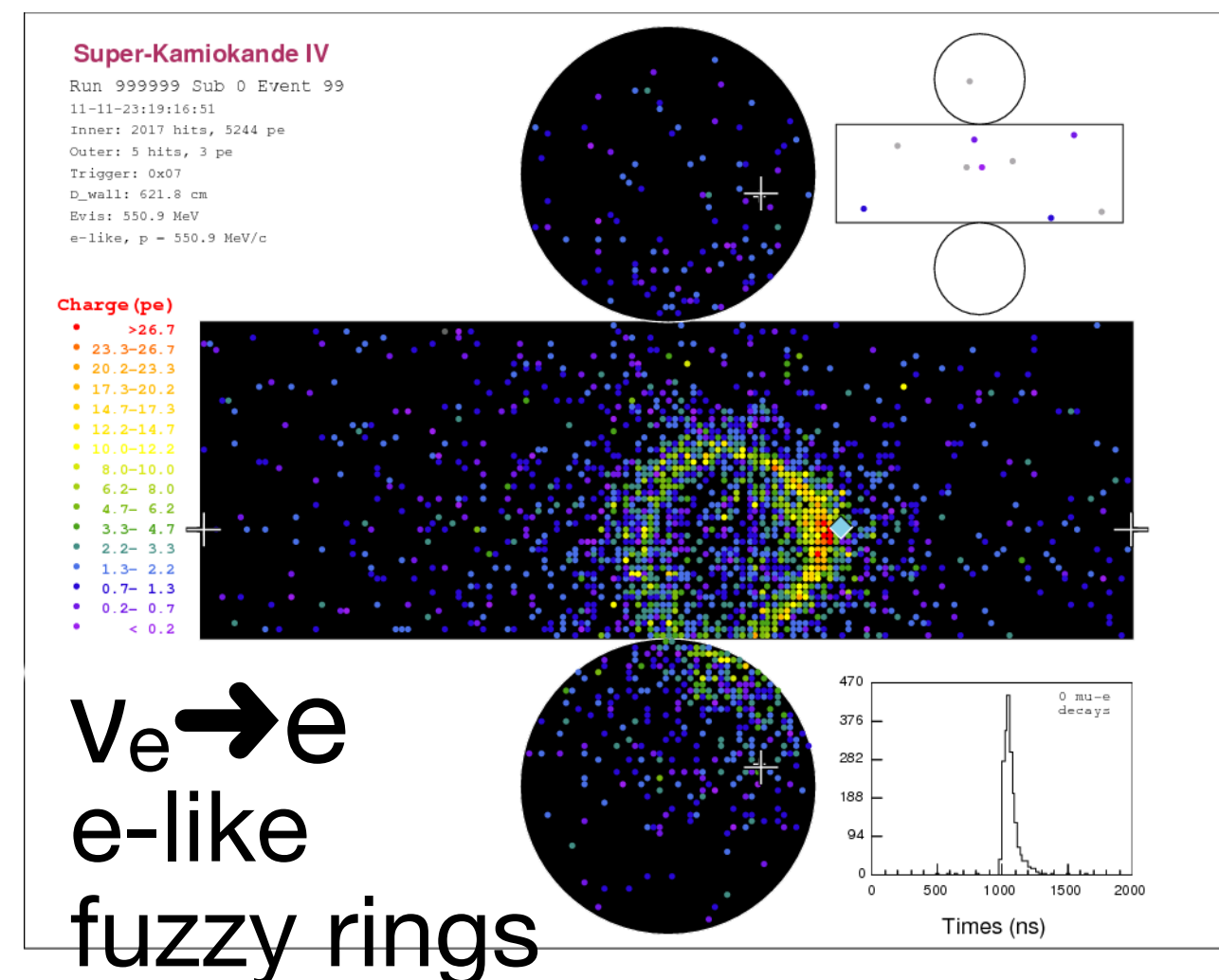
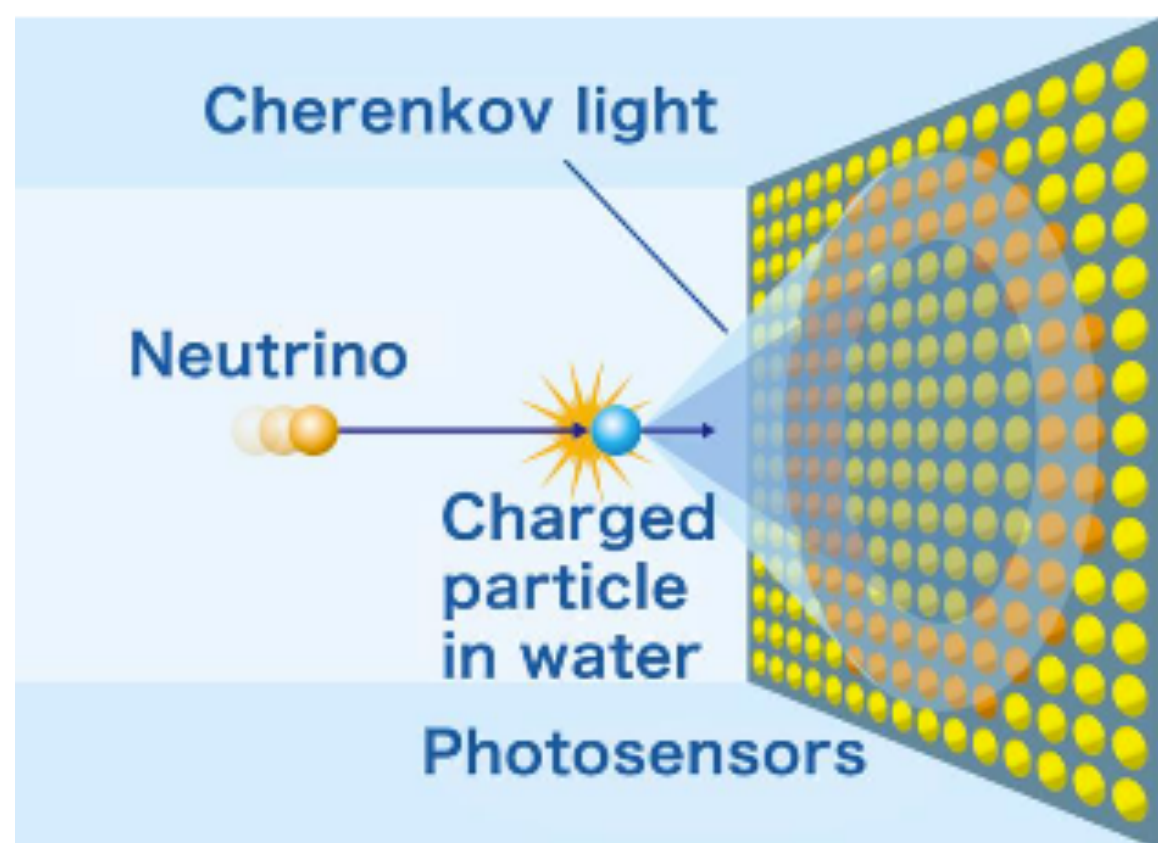

20" PMTs QA

- Mass testing for dark rate stability in 2 rooms of 100 PMTs
- Quality monitoring since 2021



Multi-PMT position

- LED-mPMTs are distributed as uniform as possible
- TEC and BEC distribution is the same

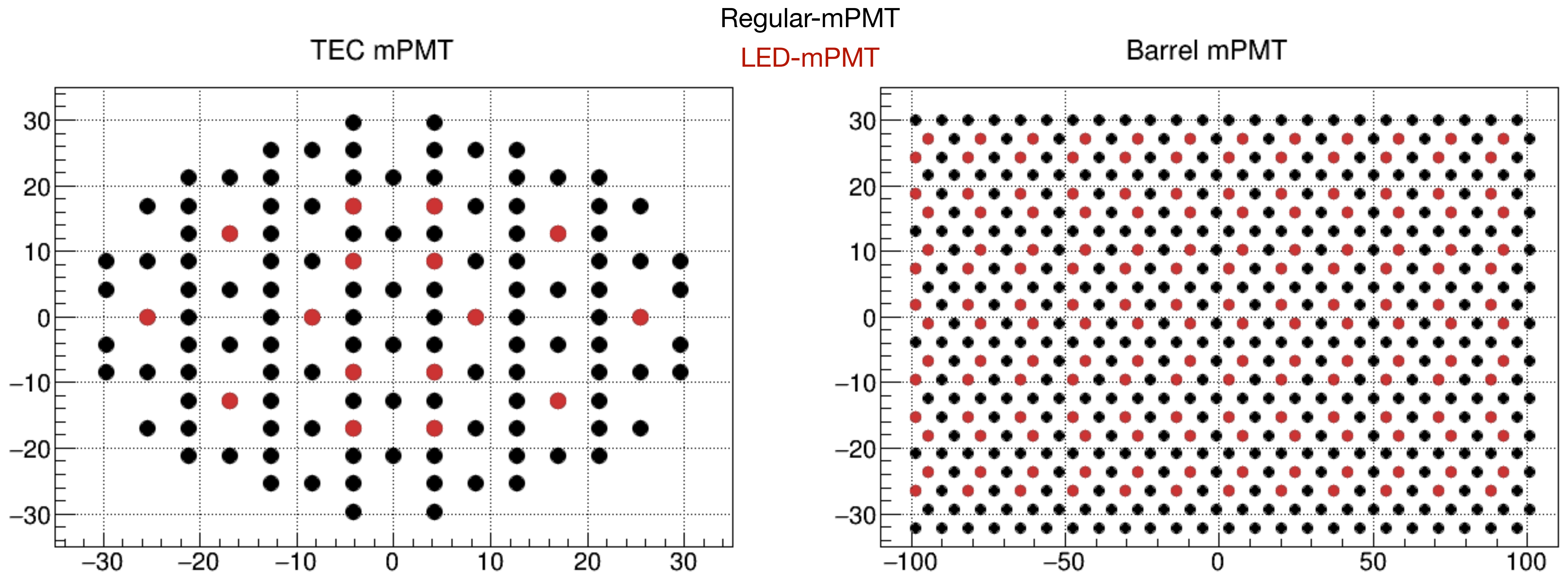

HK event samples

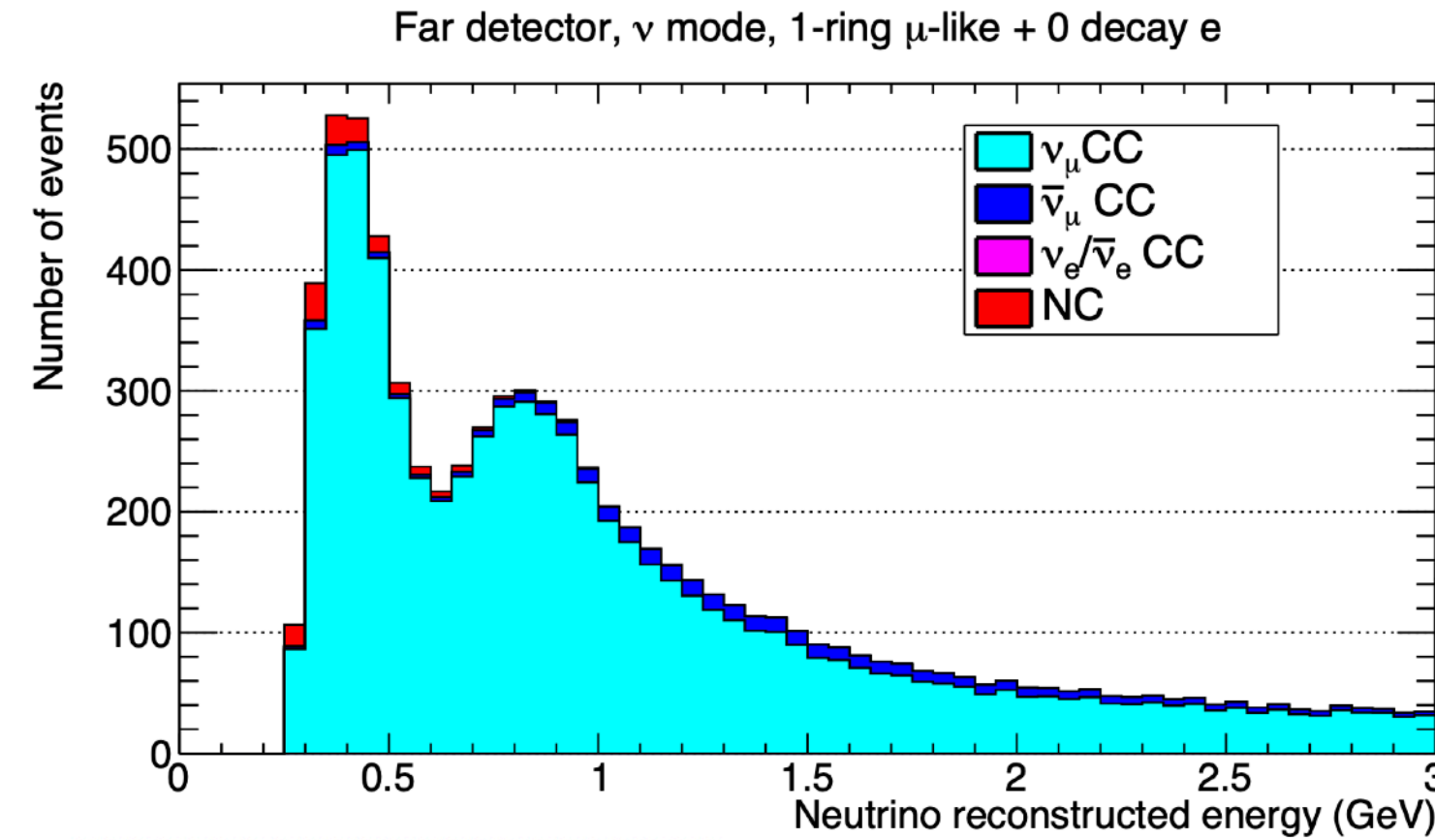

Hyper-K preliminary
 10 years (2.7×10^{22} POT 1:3 $\nu\bar{\nu}$)
 True Normal Ordering, $\sin^2\theta_{13}=0.0218$, $\sin^2\theta_{23}=0.528$, $\Delta m_{32}^2=2.509 \times 10^{-3} \text{eV}^2/c^4$, $\delta_{CP}=-1.601$

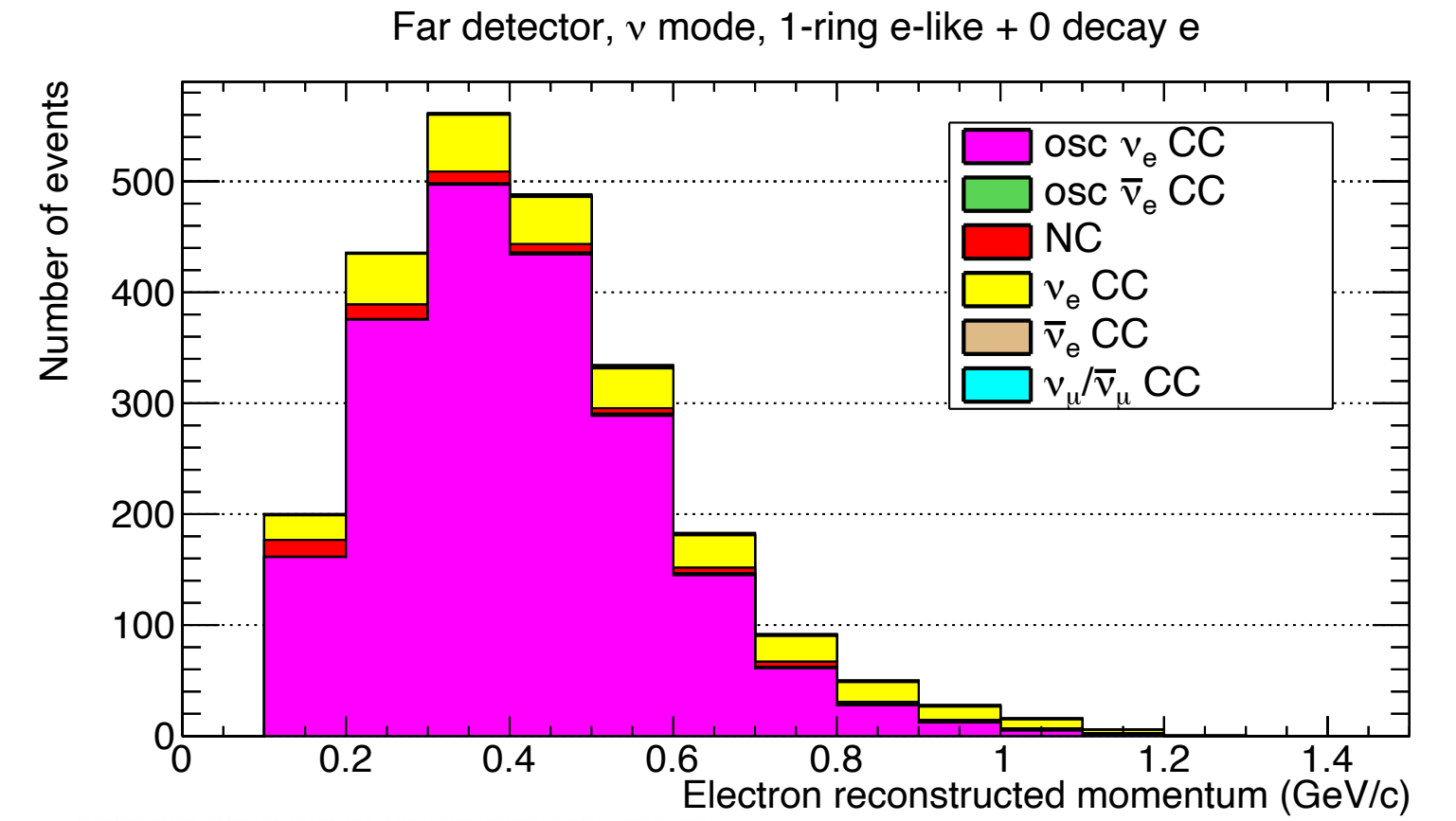

Hyper-K preliminary
 10 years (2.7×10^{22} POT 1:3 $\nu\bar{\nu}$)
 True Normal Ordering, $\sin^2\theta_{13}=0.0218$, $\sin^2\theta_{23}=0.528$, $\Delta m_{32}^2=2.509 \times 10^{-3} \text{eV}^2/c^4$, $\delta_{CP}=-1.601$

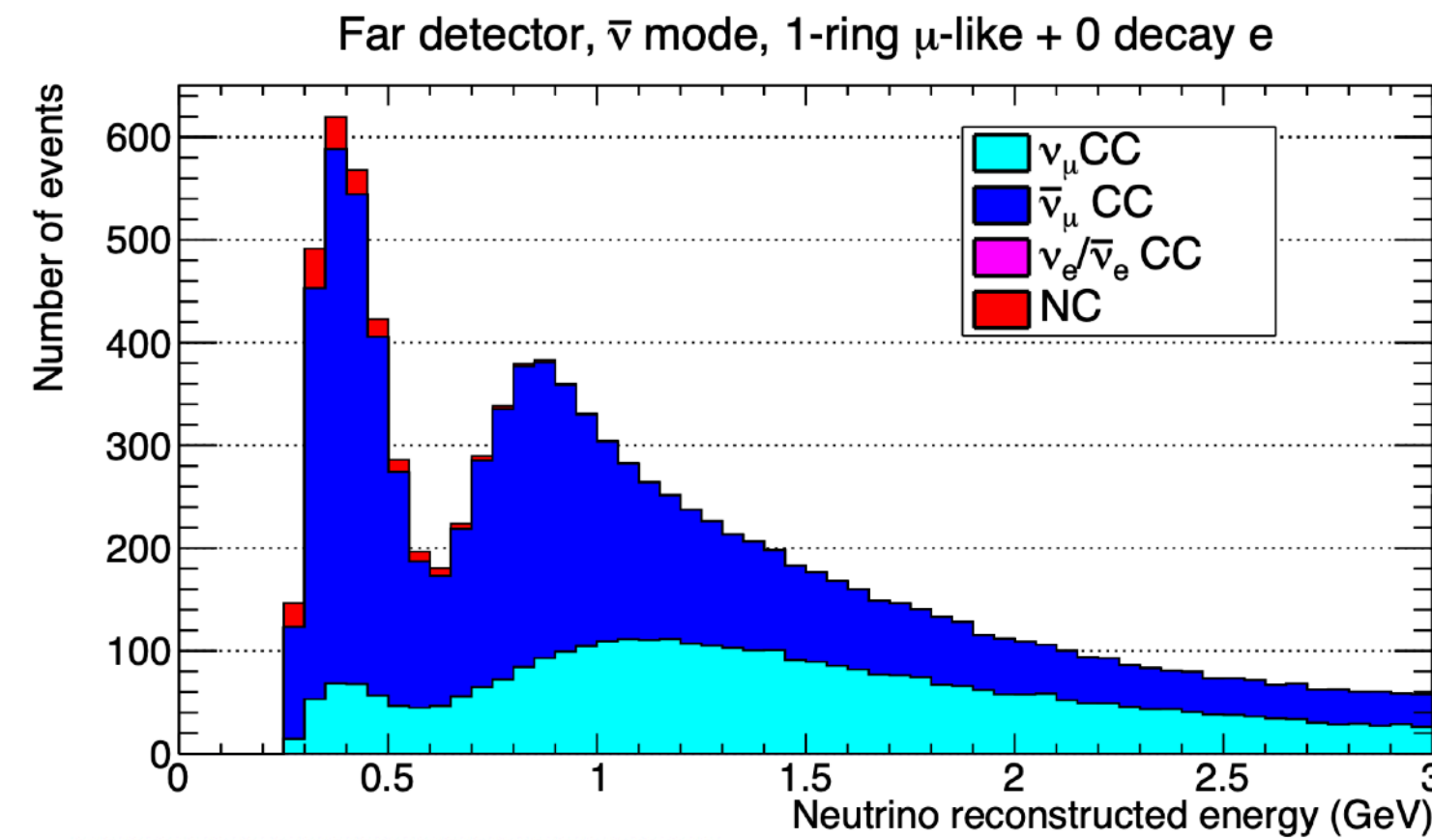

Hyper-K preliminary
 10 years (2.7×10^{22} POT 1:3 $\nu\bar{\nu}$)
 True Normal Ordering, $\sin^2\theta_{13}=0.0218$, $\sin^2\theta_{23}=0.528$, $\Delta m_{32}^2=2.509 \times 10^{-3} \text{eV}^2/c^4$, $\delta_{CP}=-1.601$

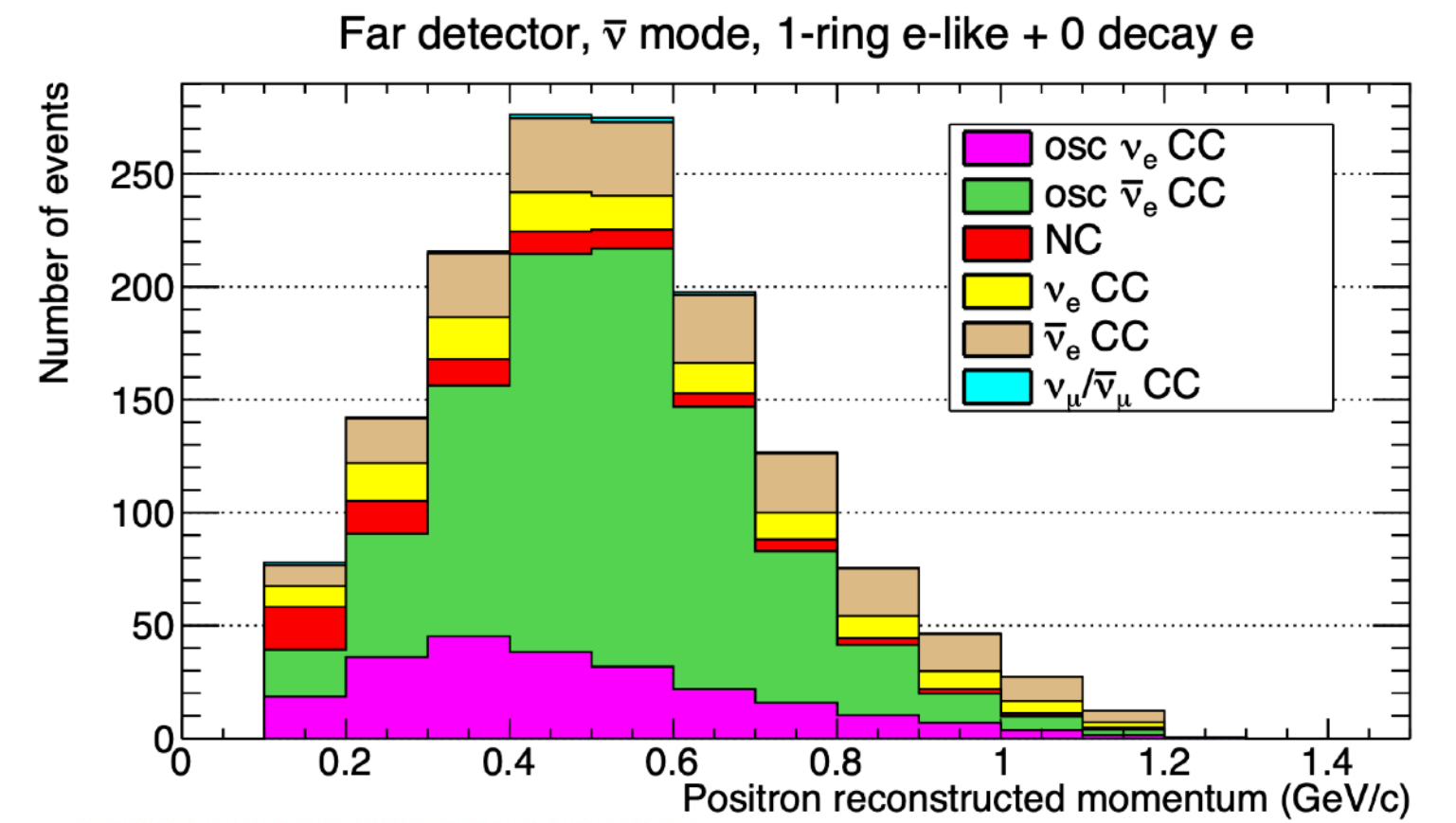

Hyper-K preliminary
 10 years (2.7×10^{22} POT 1:3 $\nu\bar{\nu}$)
 True Normal Ordering, $\sin^2\theta_{13}=0.0218$, $\sin^2\theta_{23}=0.528$, $\Delta m_{32}^2=2.509 \times 10^{-3} \text{eV}^2/c^4$, $\delta_{CP}=-1.601$

$$E_{\nu}^{\text{rec}} = \frac{2(m_n - V)E_{\ell} + m_p^2 - (m_n - V)^2 - m_{\ell}^2}{2(m_n - V - E_{\ell} + p_{\ell} \cos \theta_{\ell})}$$

Neutrino interactions at few GeV

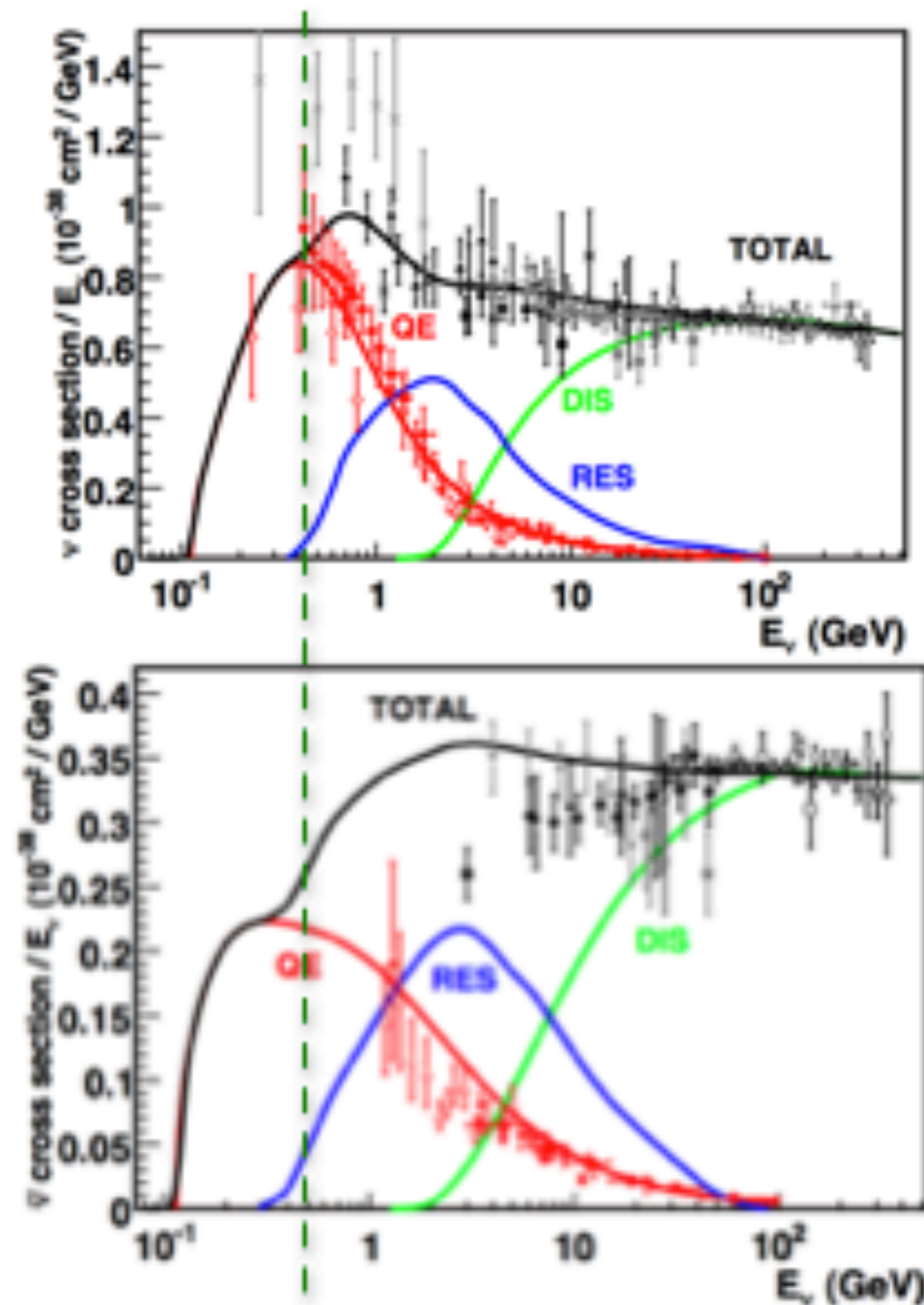

T2K peak energy
~0.6 GeV

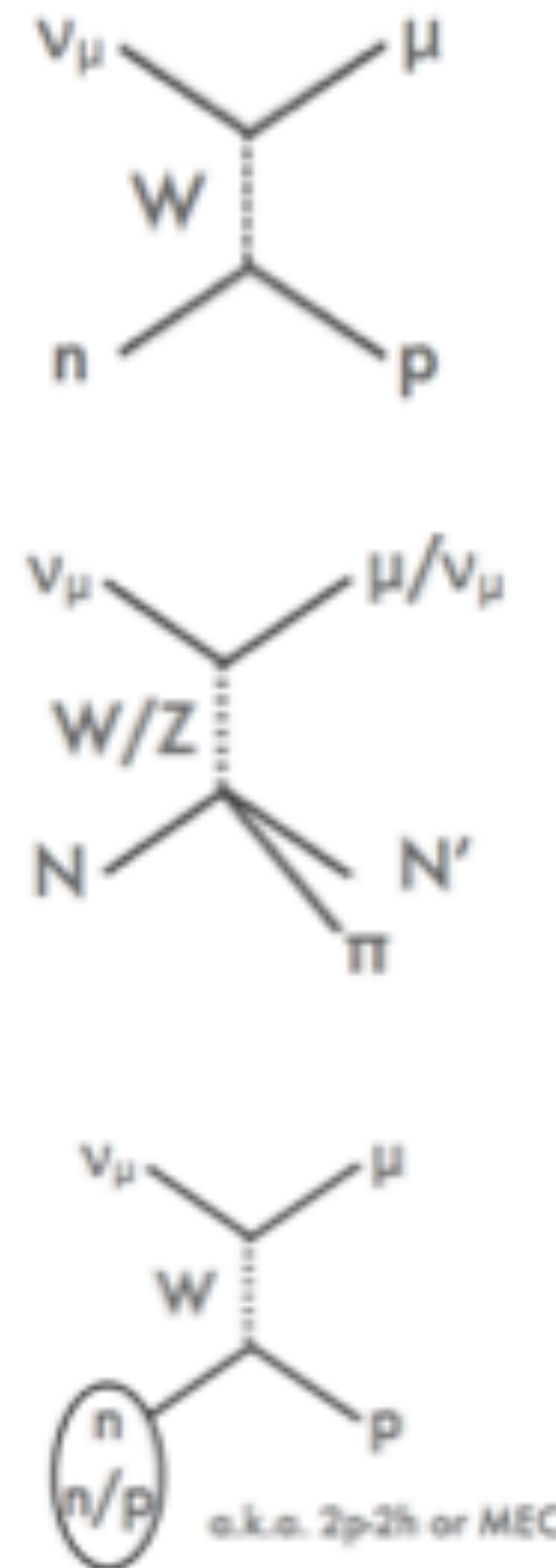

- CC-QE
 - $\nu_{\mu^-} + n \rightarrow \mu^- + p$
 - Dominant at T2K energies
 - Neutrino energy reconstruction from muon kinematics only
- CC-RES
 - $\nu_{\mu^-} + p \rightarrow \mu^- + p + \pi^+$
 - Pion could be missing due to intra-nuclear interactions and misidentified as CC-QE
- Multi-nucleon (2p-2h) interactions
 - $\nu_{\mu^-} + [np] \rightarrow \mu^- + p + p$
 - CCQE-like but different kinematics

Sensitivity to $\delta_{CP} \neq 0$

- Sensitive to the CP violation phase by measuring the difference between $P(\nu\mu \rightarrow \nu e)$ and $P(\bar{\nu}\mu \rightarrow \bar{\nu} e)$
- Expected number of e-like events after 10 years of HK operation:

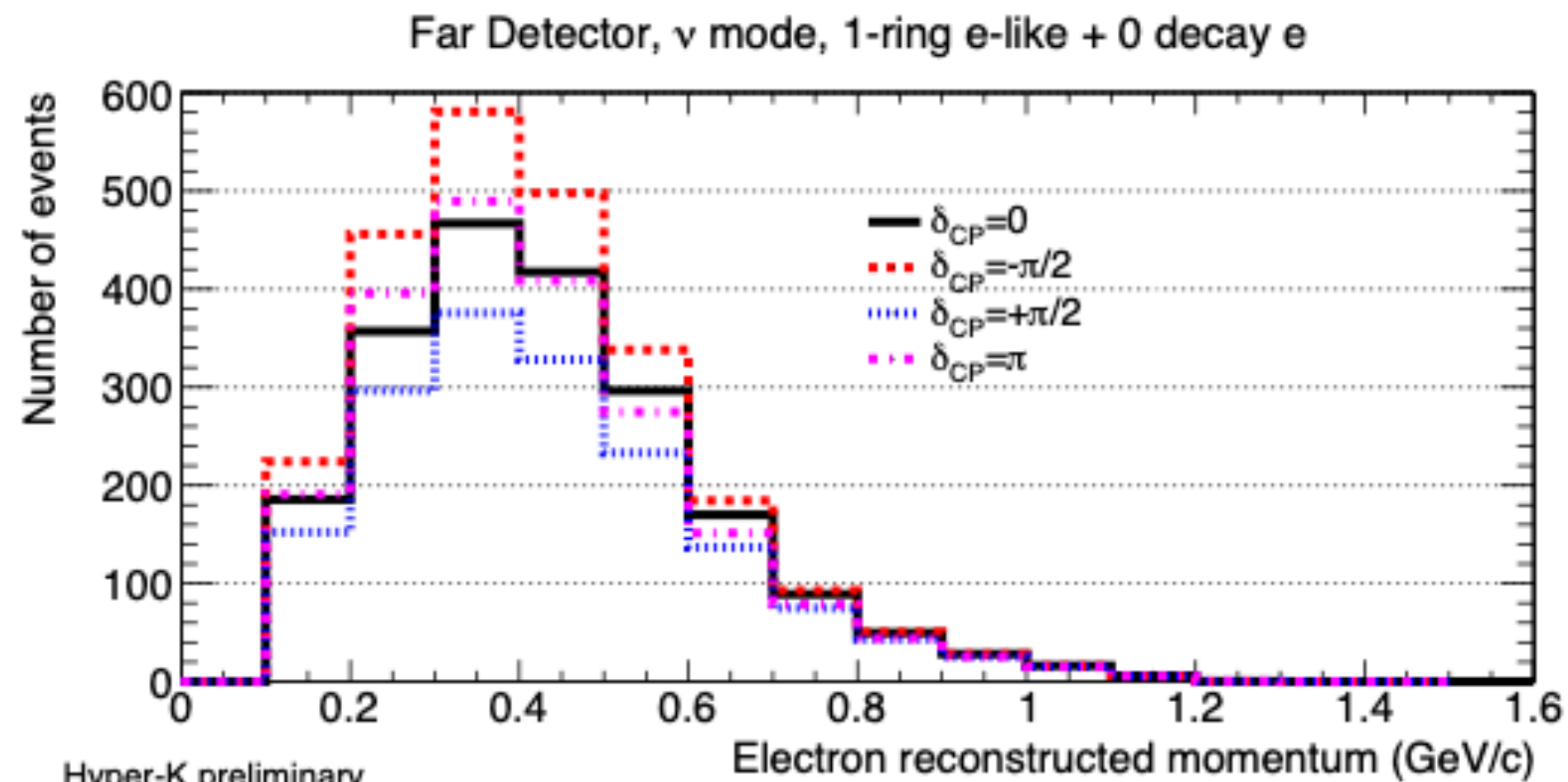

Hyper-K preliminary
 10 years (2.7×10^{22} POT 1:3 $\nu\bar{\nu}$)
 True Normal Ordering, $\sin^2\theta_{13}=0.0218$, $\sin^2\theta_{23}=0.528$, $\Delta m_{32}^2=2.509 \times 10^{-3} \text{eV}^2/c^4$

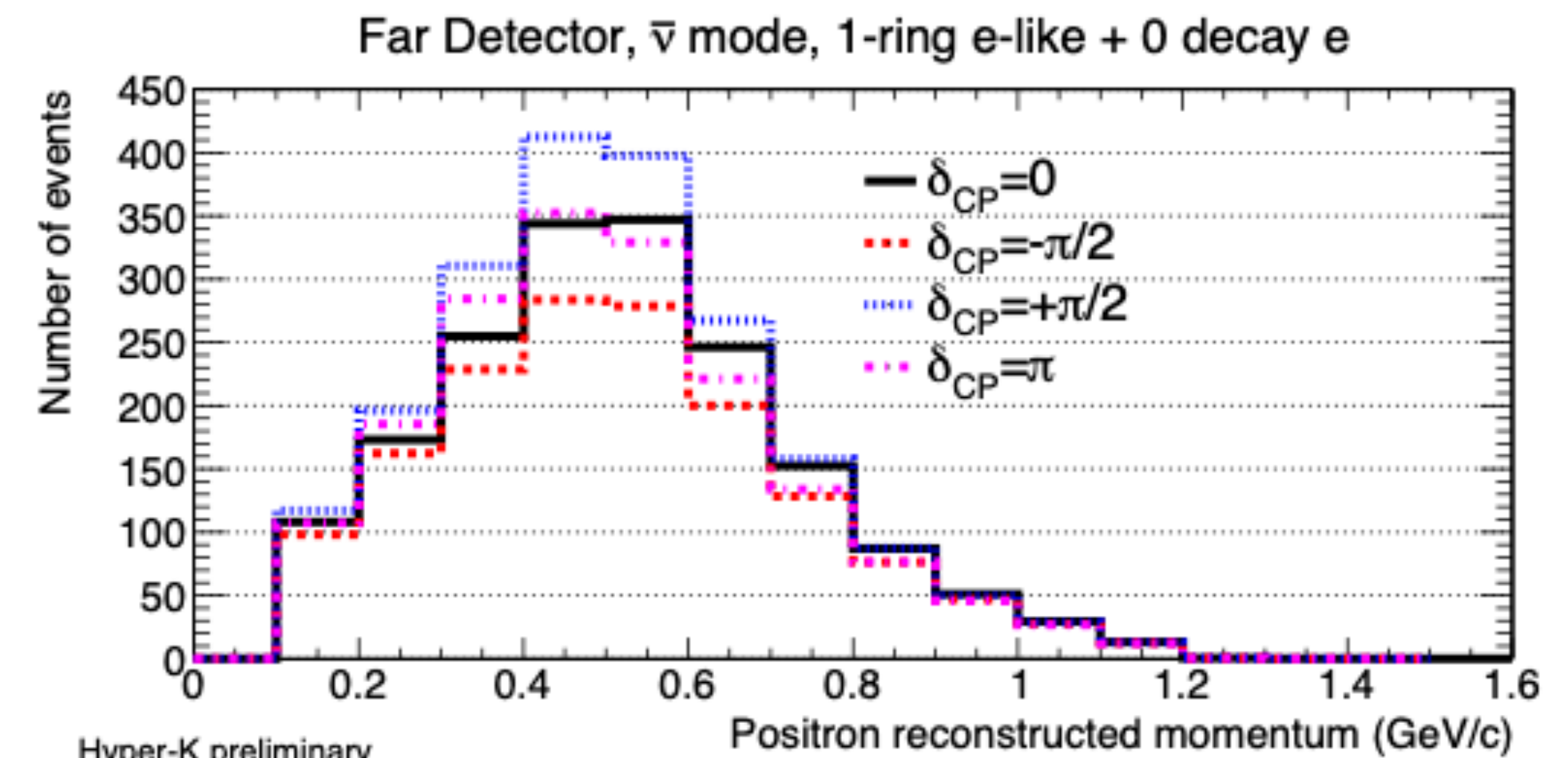

Hyper-K preliminary
 10 years (2.7×10^{22} POT 1:3 $\nu\bar{\nu}$)
 True Normal Ordering, $\sin^2\theta_{13}=0.0218$, $\sin^2\theta_{23}=0.528$, $\Delta m_{32}^2=2.509 \times 10^{-3} \text{eV}^2/c^4$

Sensitivity to $\delta_{CP} \neq 0$

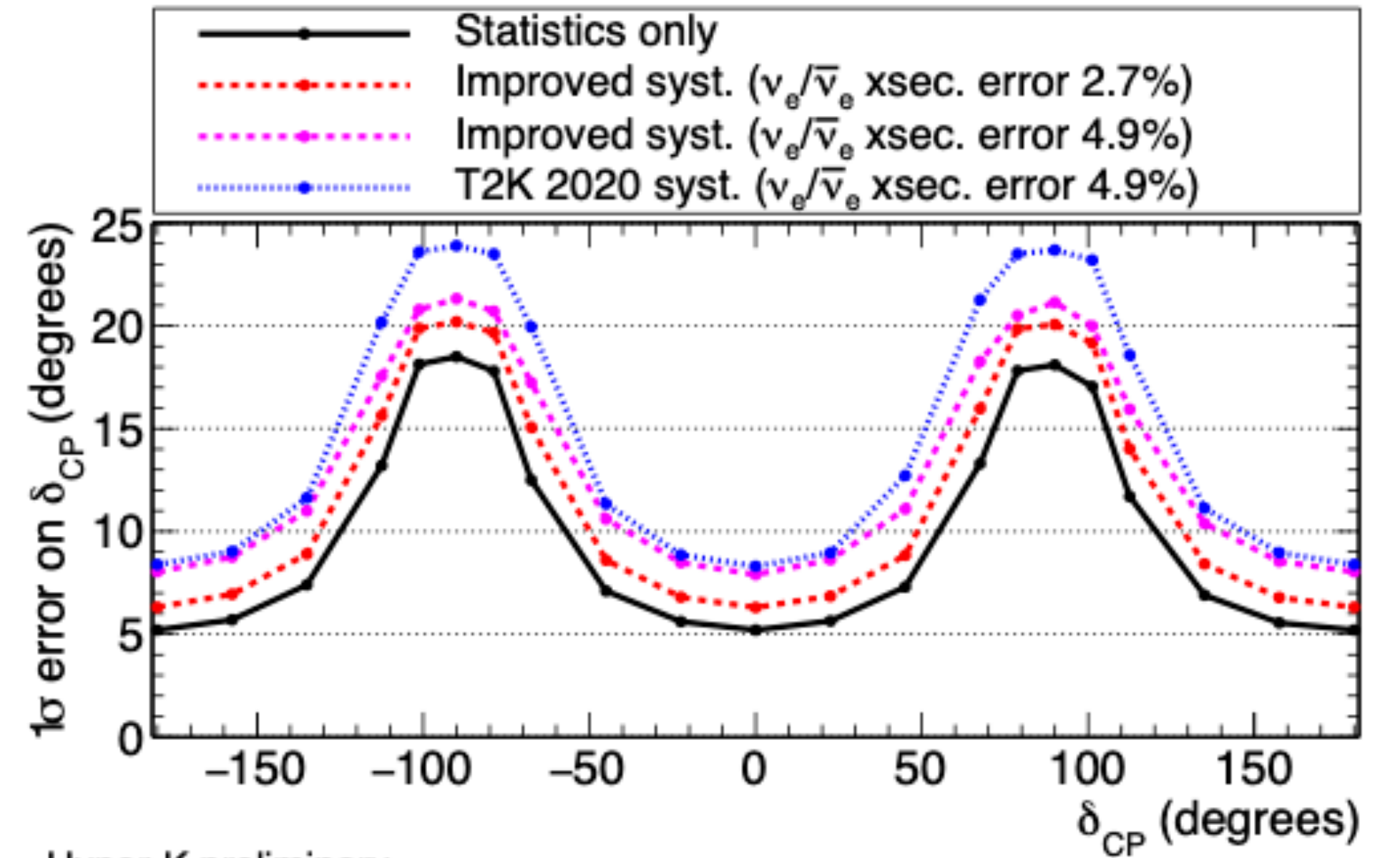
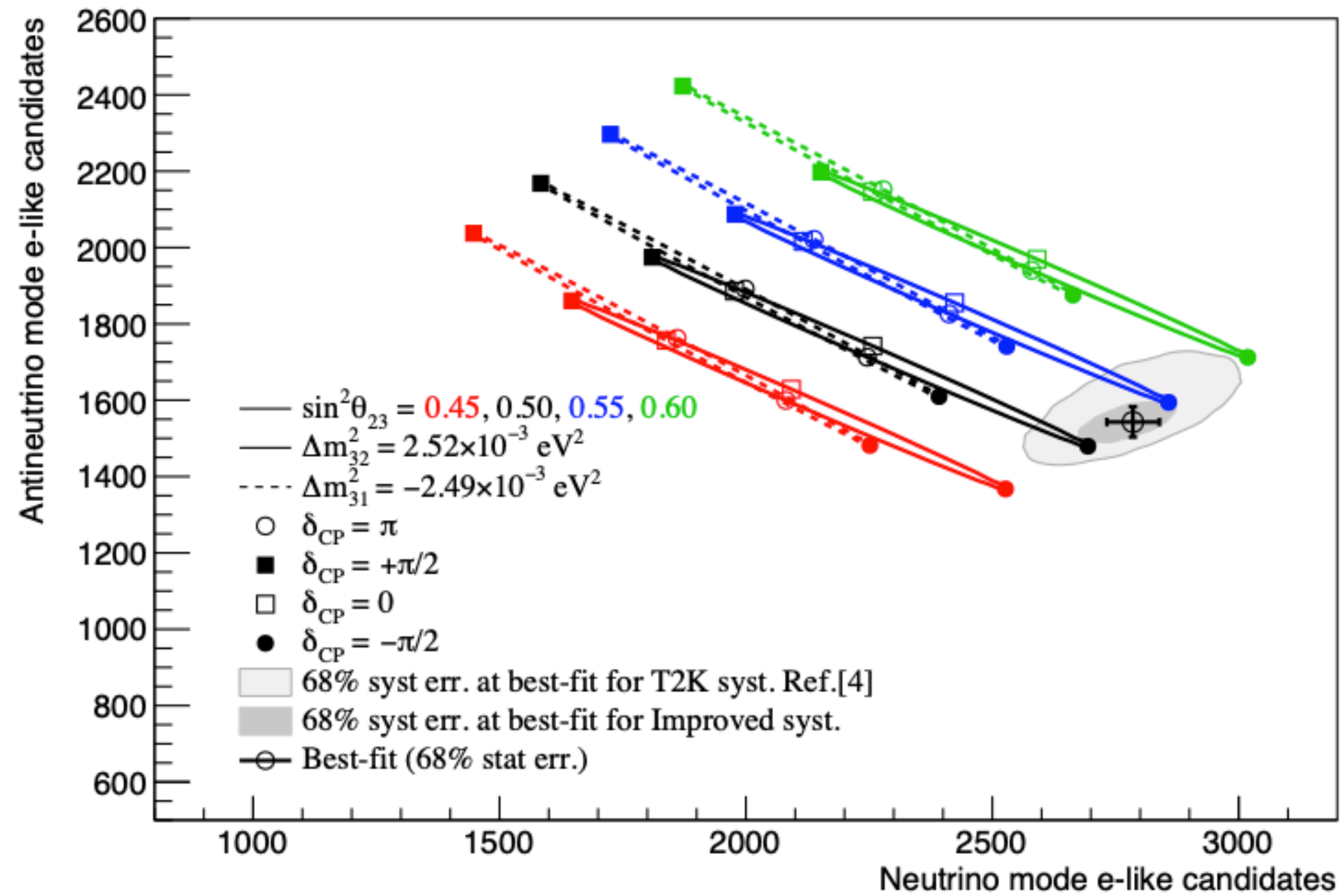

Hyper-K preliminary

True normal ordering (known), HK 10 Years (2.7×10^{22} POT 1:3 $\nu:\bar{\nu}$)
 $\sin^2\theta_{13} = 0.0218 \pm 0.0007$, $\sin^2\theta_{23} = 0.528$, $\Delta m_{32}^2 = 2.509 \times 10^{-3} \text{ eV}^2/c^4$

Solar neutrinos

- The sun only produces ν_e
- Tension between solar and KamLAND/JUNO Δm^2_{21} measurements
- Reject day/night asymmetry at 5σ in 10 years
- Sensitivity of $3-5\sigma$ for upturn discovery after 10 years of running

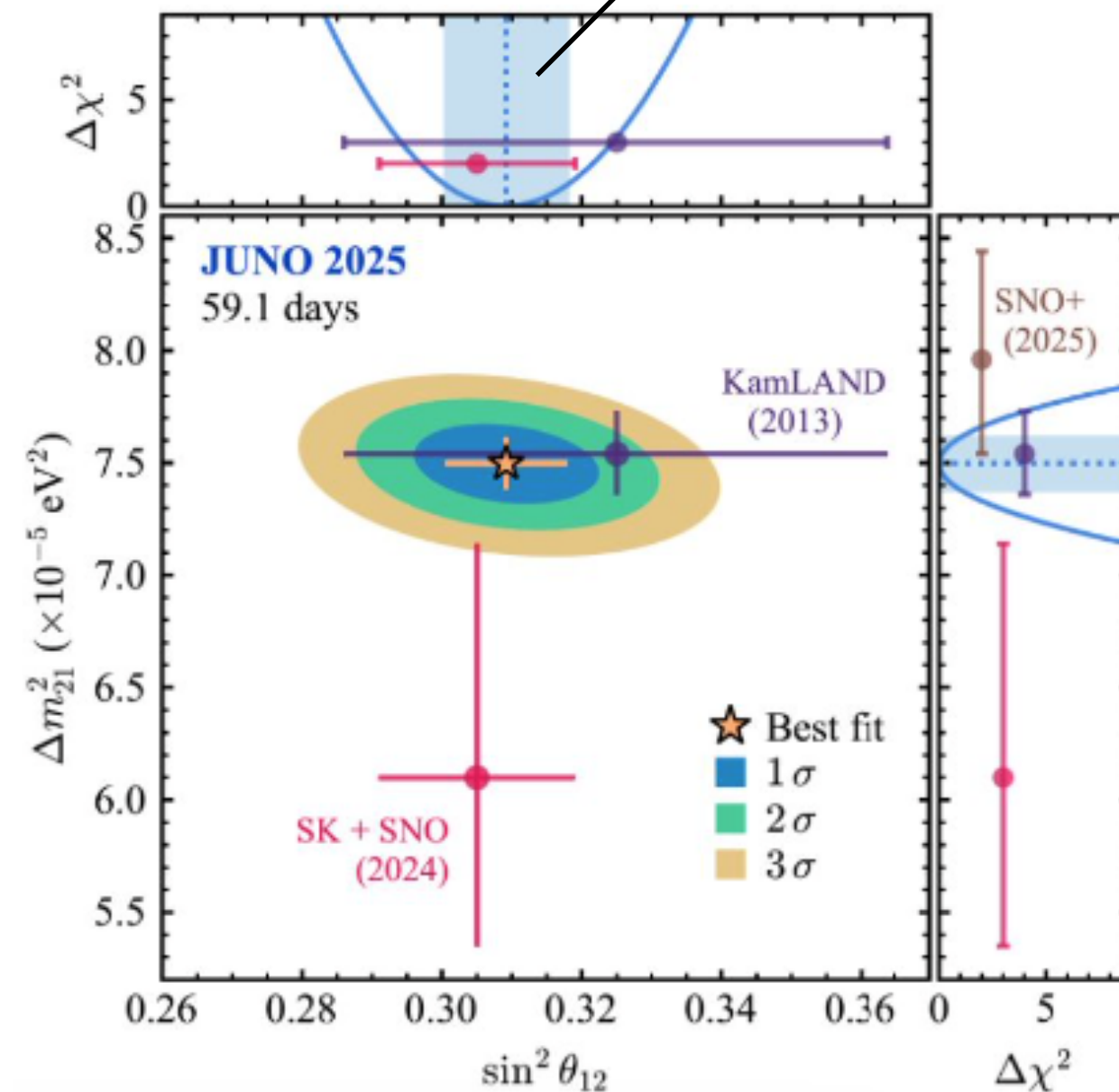
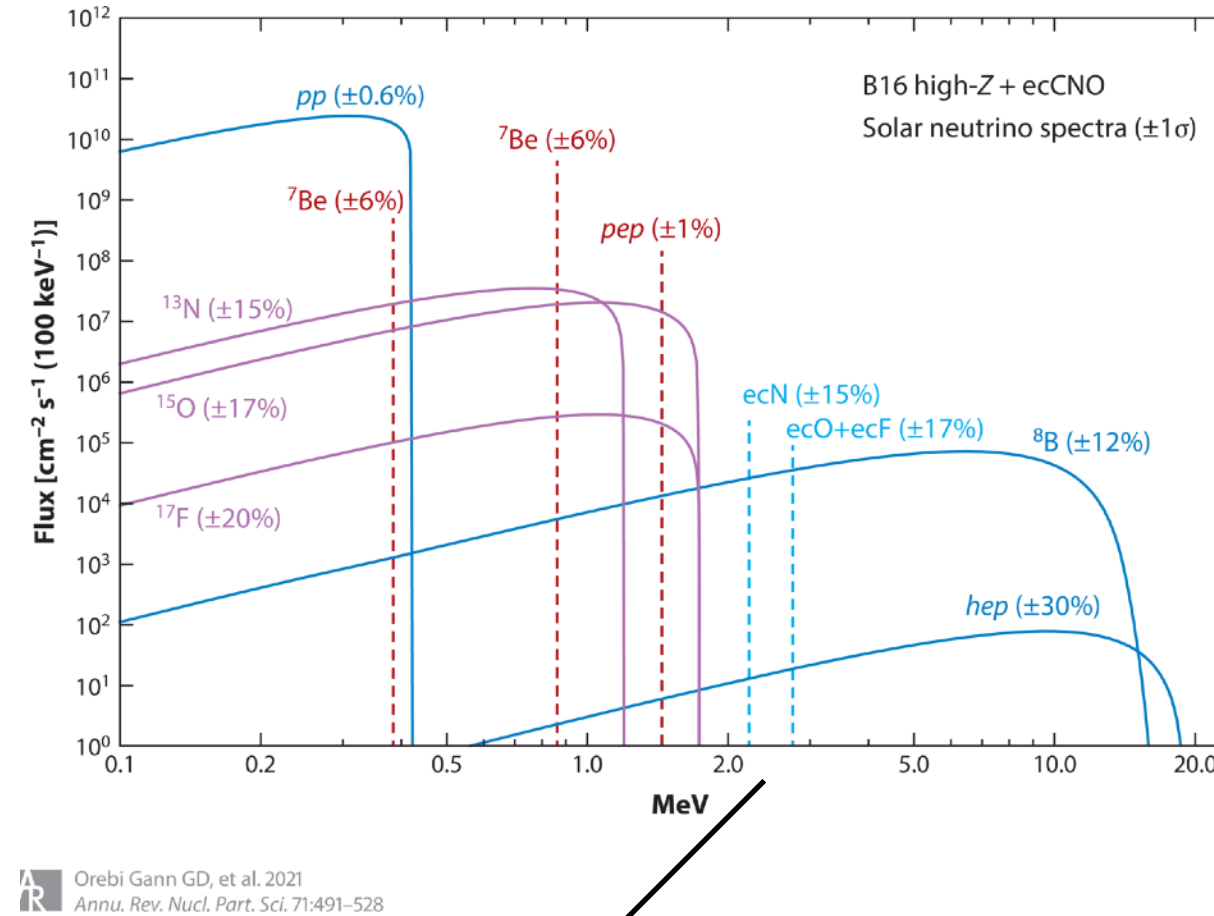

Day/Night Asymmetry Sensitivity

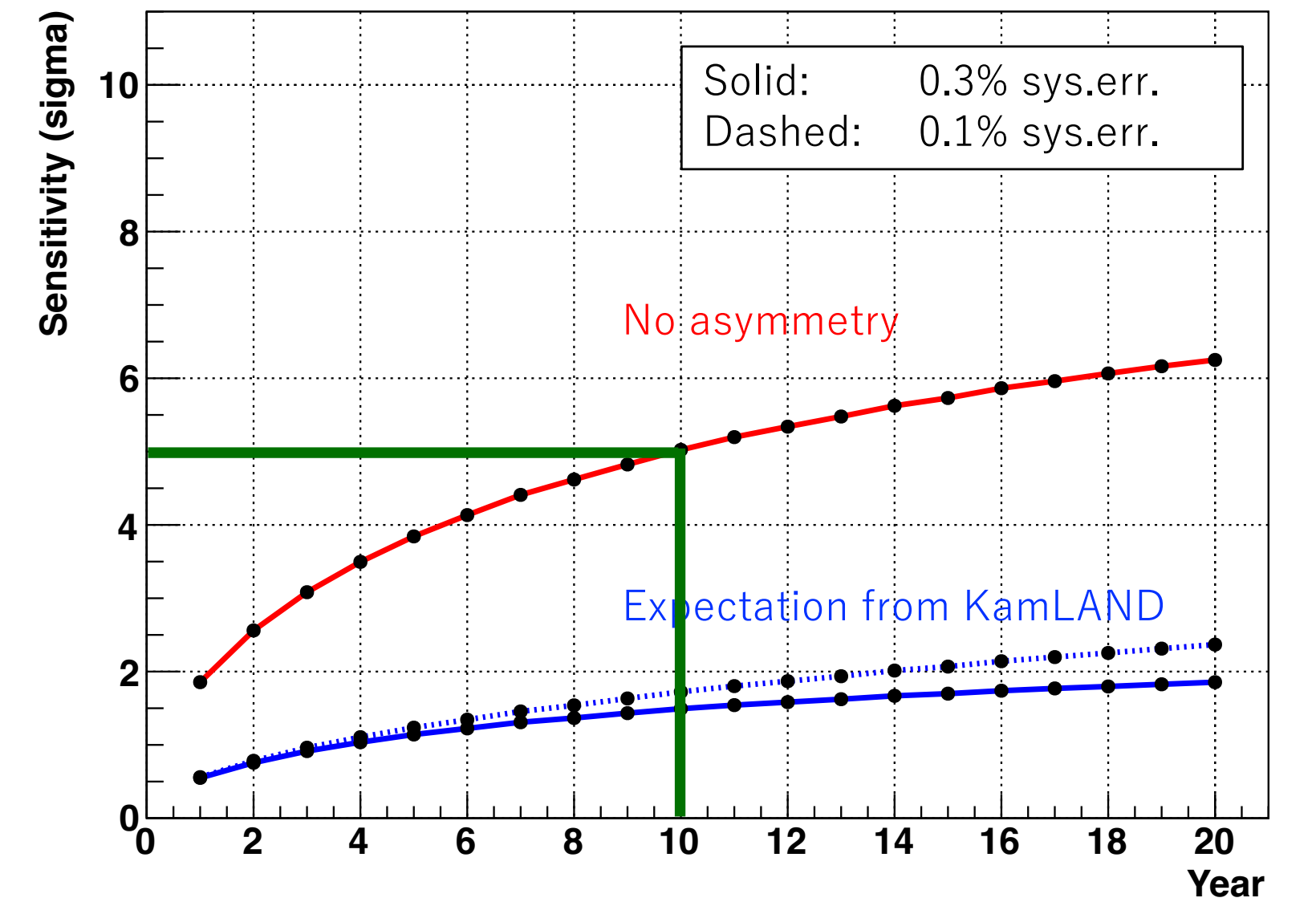

Upturn Discovery Sensitivity

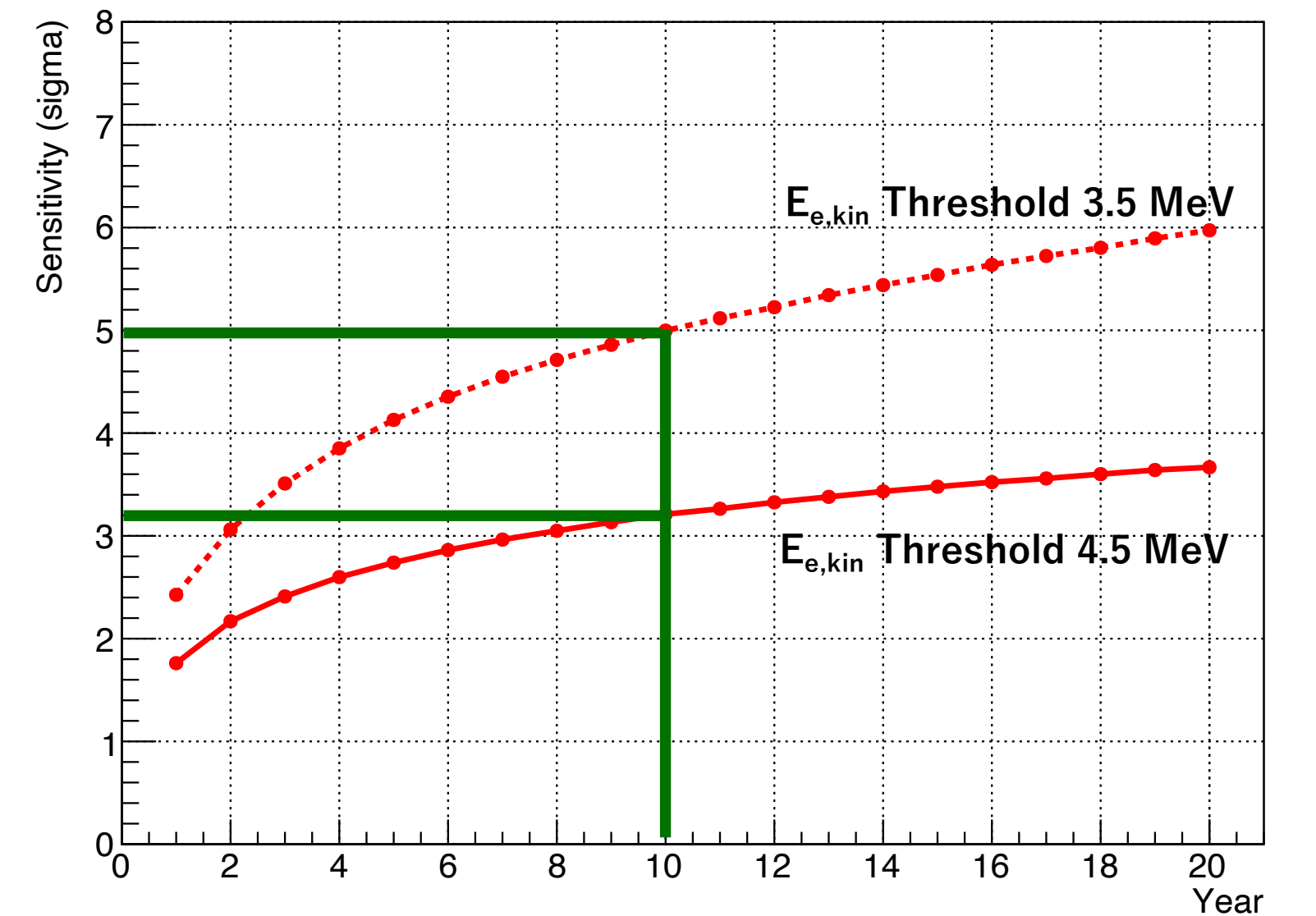

$\nu_\mu/\bar{\nu}_\mu$ enhanced beam

