



The Atacama Large Millimeter/submm Array (ALMA)

Carlos De Breuck (ESO)

The ALMA global partnership



ALMA: a
worldwide
collaboration

ALMA is a partnership of ESO, NSF (USA) and NINS (Japan), together with NRC (Canada), MOST and ASIAA (Taiwan), and KASI (Republic of Korea), in cooperation with the Republic of Chile.

The Joint ALMA Observatory is operated by ESO, AUI/NRAO and NAOJ.

What are ALMA's current capabilities?



Atmospheric transmission at Chajnantor, pwv = 0.5 mm

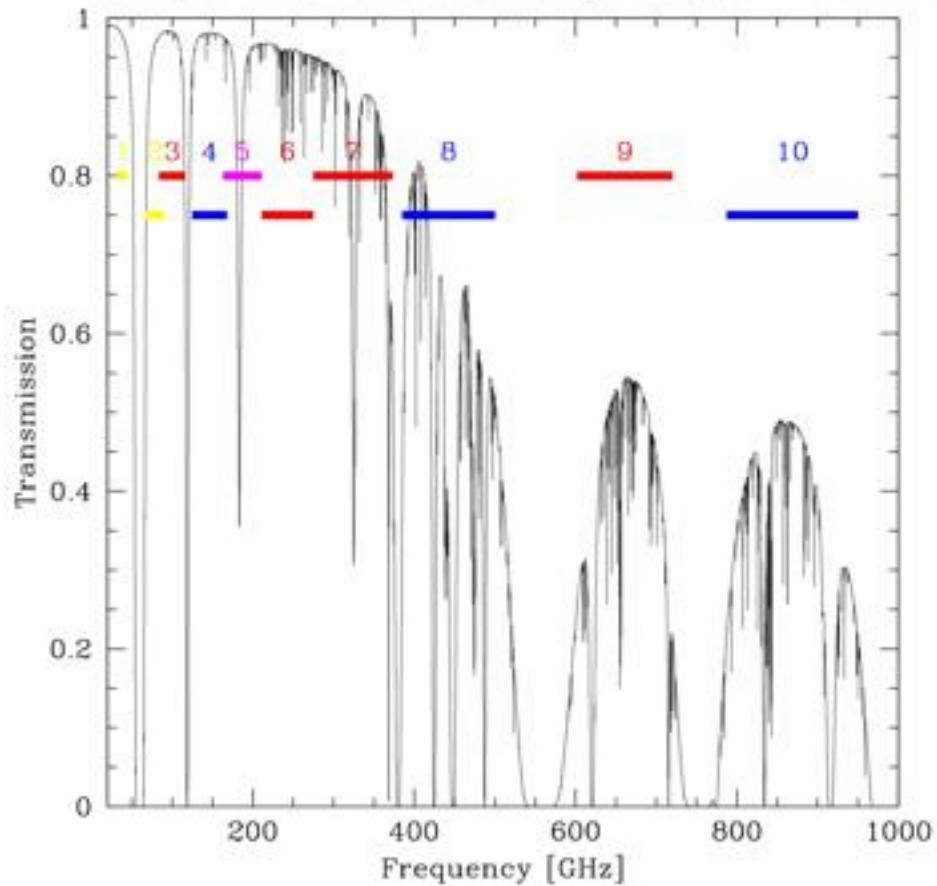

- 54x12m + 12x7m antennas
- Configurable baselines up to 16km
- 10 frequency bands from 35 to 950 GHz
- Excellent 5000m elevation site opening up submm atmospheric windows
- Current correlator can handle 4GHz bandwidth in two sidebands/polarizations





Selected ALMA science results

Band 9 Total Power image of the Sun

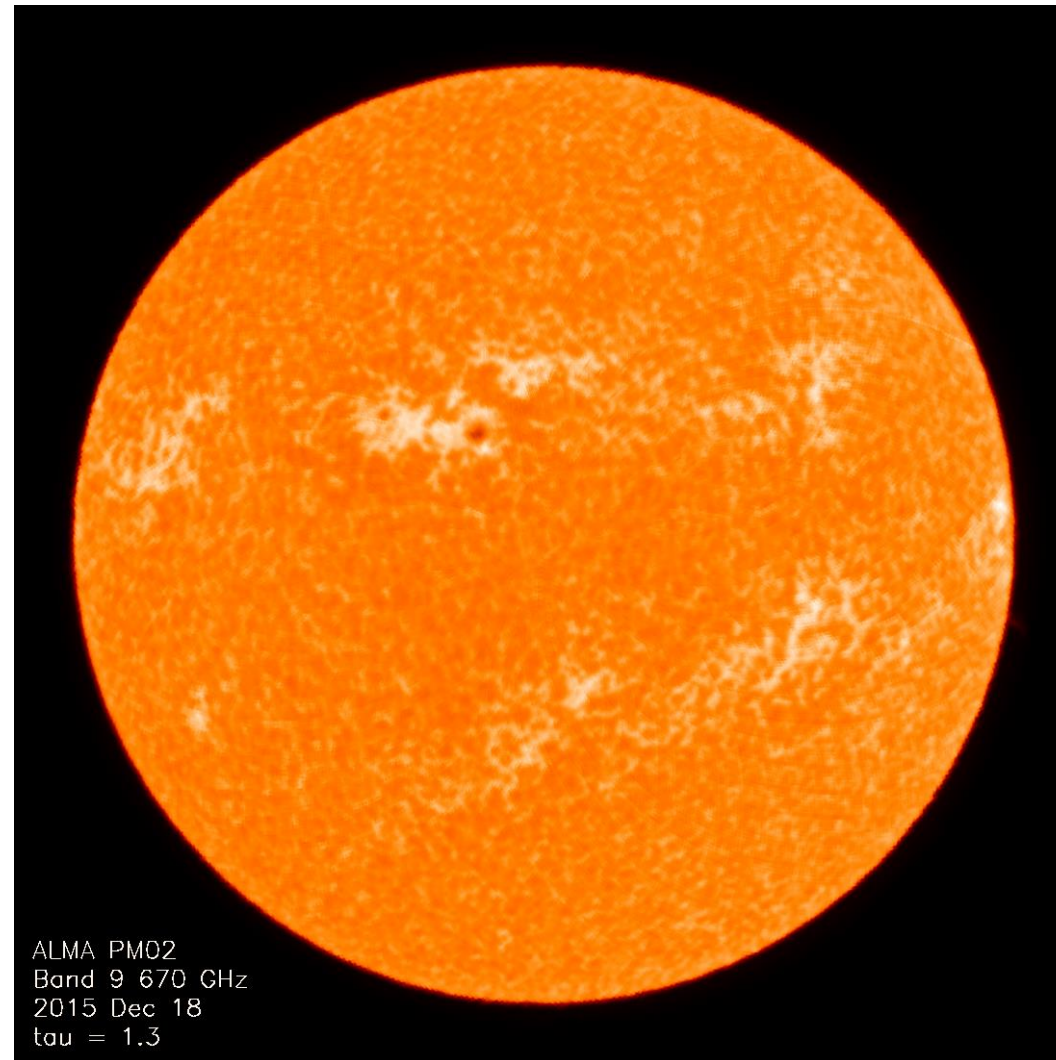

Interstellar Visitor: Comet 3I/ATLAS



Optical Image

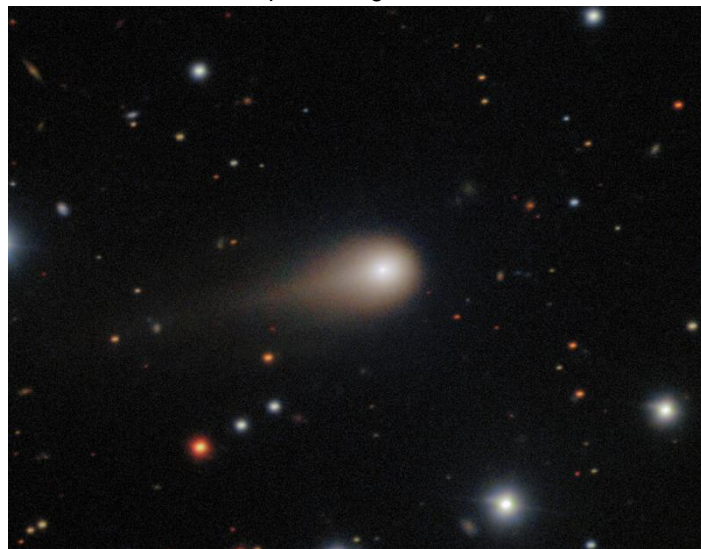

ALMA Observations at 4 epochs

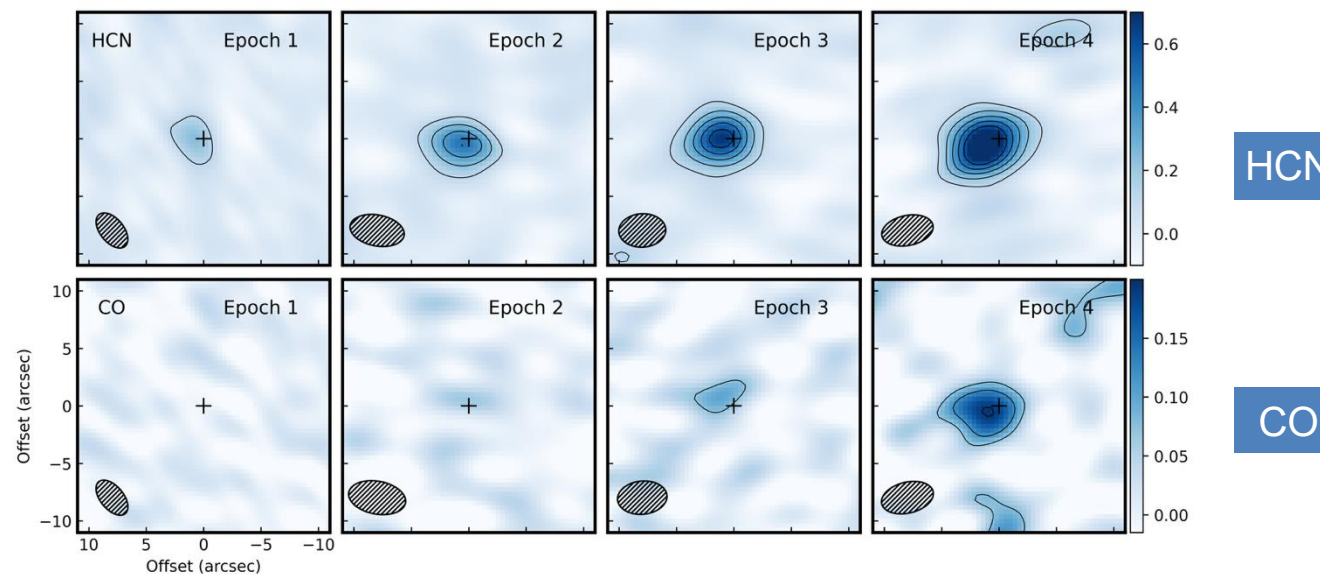

- Comet originated from another (unknown) solar system
 - only the third interstellar comet identified so far, but more to come with Rubin!
 - Has been traveling in interstellar space for billions of years before passing through our solar system for a few months
- Provides insights into the conditions in the disk of another planetary system
- ALMA observations underway
 - High resolution observations to constrain nucleus size
 - Time monitoring of key molecules (HCN / CO): measure physical properties (see Figure)
 - Measurement of the Deuterium/Hydrogen ratio: implications for the production of water in another solar system
 - Measurements of organic molecules: measure inventory of organic molecules

Volcanic history on Io

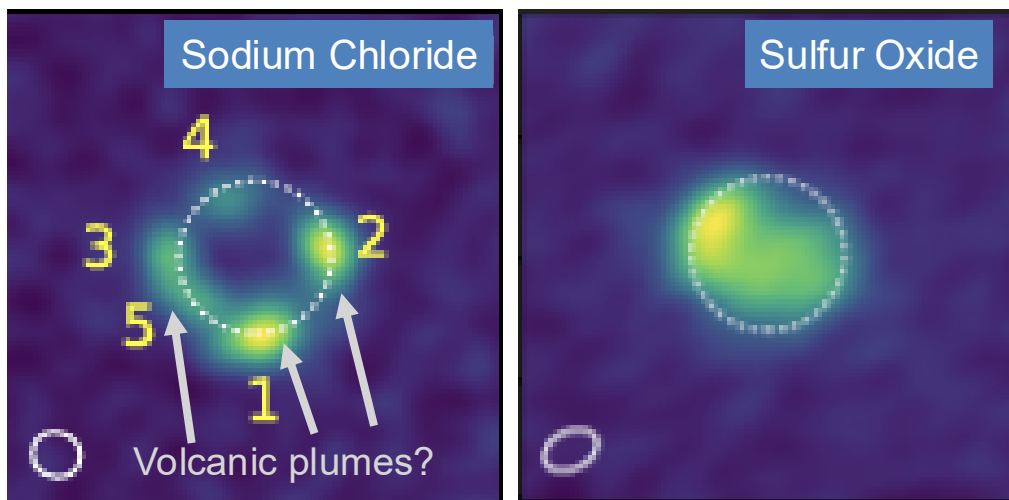

- ALMA observations of Jupiter's moon Io
 - most volcanically active bodies in the solar system
- Observed 16 chemical species of Sodium Chloride (NaCl) and Sulfur Oxide (SO)
 - two of the maps are shown here
- Spatial distribution of SO and NaCl
 - SO located at low and mid latitudes
 - NaCl confined to a few localized regions, interpreted as volcanic plumes
- Analysis shows a very high isotopic abundances of chlorine (see figure) and sulfur
 - lighter isotopic molecules are preferentially lost from the atmosphere, which increases the abundance ratio (high to low isotopic species)
- results suggest Io has been volcanically active for most of its history

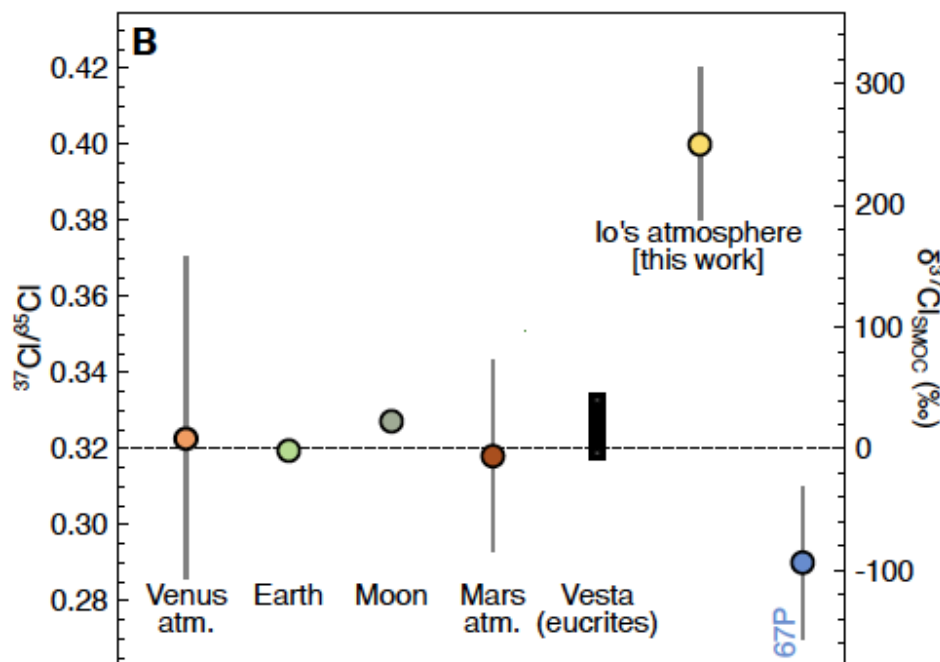

Band 9 observations of HL Tau at 1.7 au spatial resolution

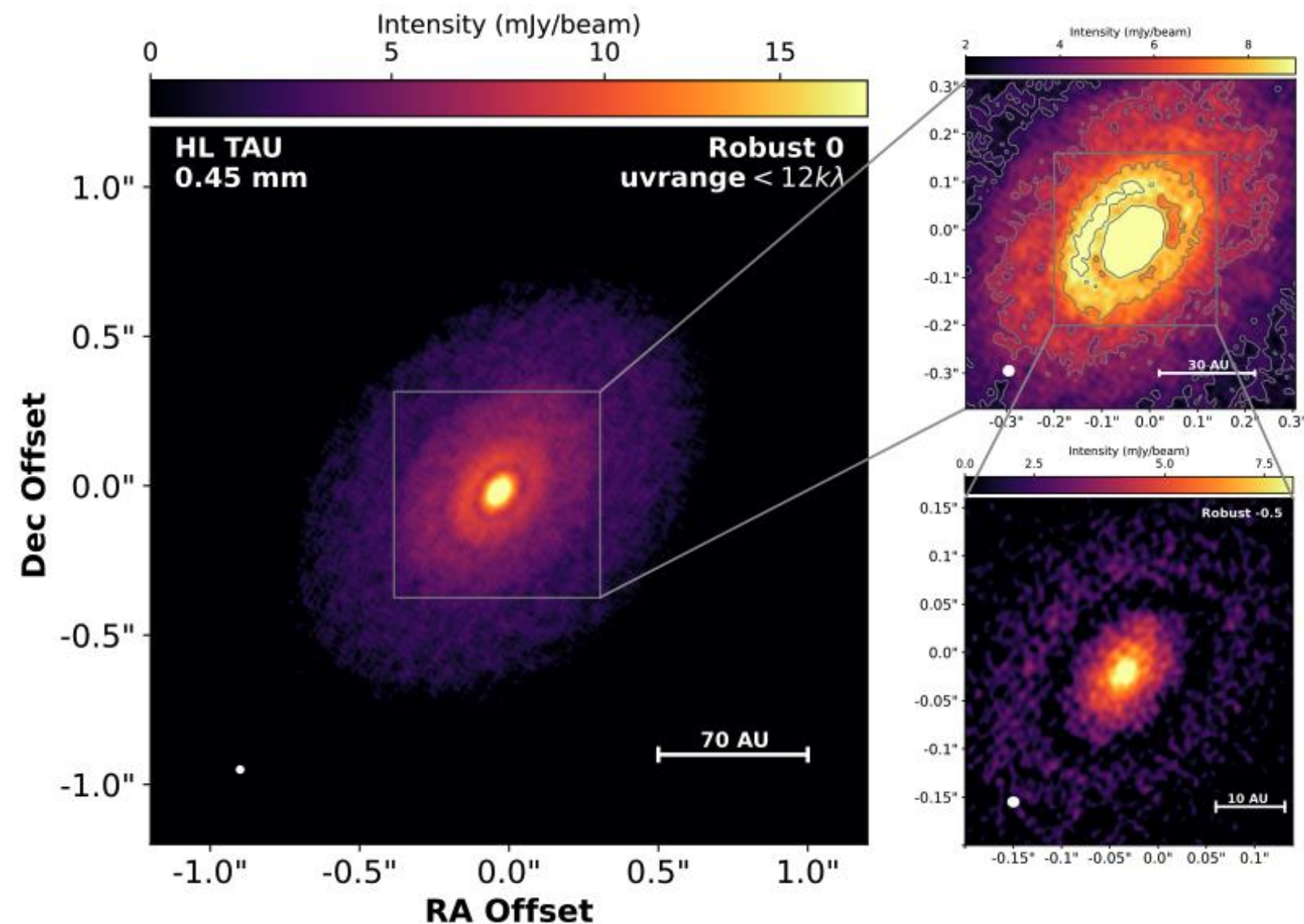

- Band 9 observations of HL Tau from the long-baseline high frequency campaign
 - Resolution as fine as 0.012 arcsec (1.7 au)!
- Band 9 provides tight constraints on the temperature of the dust to constrain the disk properties from multi-wavelength analysis
- Steep increase in the brightness of Band 9 emission within 5 au, which may be related to where water ice sublimates from the dust grains

Imaging the surface of star

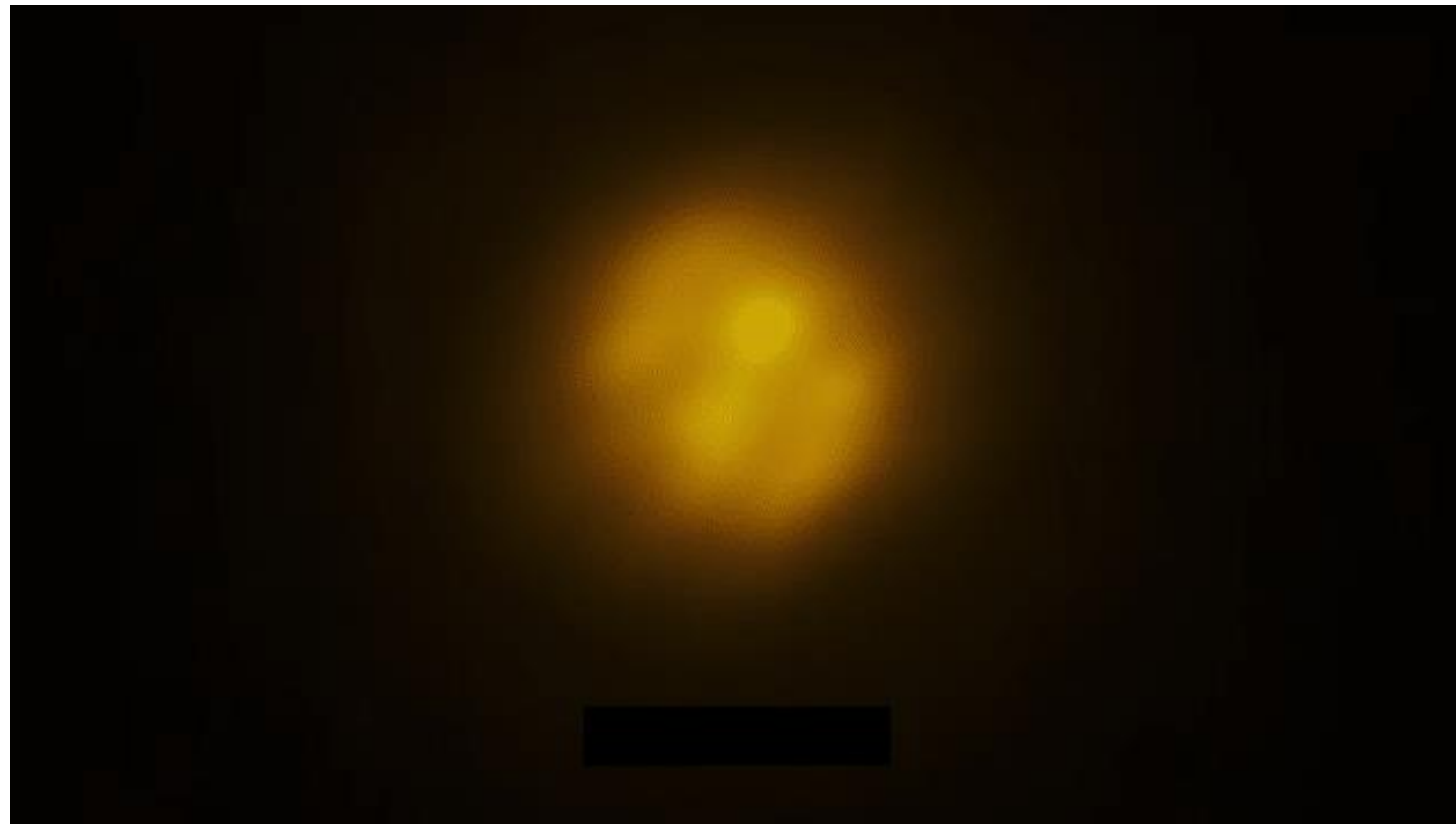

- ALMA image of the star R Doradus
 - star is 350 times larger than the Sun
- ALMA observations
 - obtained 3 separate observations over a time span of about 2 weeks
- Mixing motion in stars (convection)
 - stars produce energy in their cores through nuclear fusion
 - energy carried toward the stellar surface in hot bubbles of gas, which then cool down and sink
- Results
 - images show large, hot bubbles of gas appearing on the surface and changing over time
 - time scale (about 1 month) is faster than expected



57 Faces of a Dying Star

Molecular imaging of W Hydrae's atmosphere

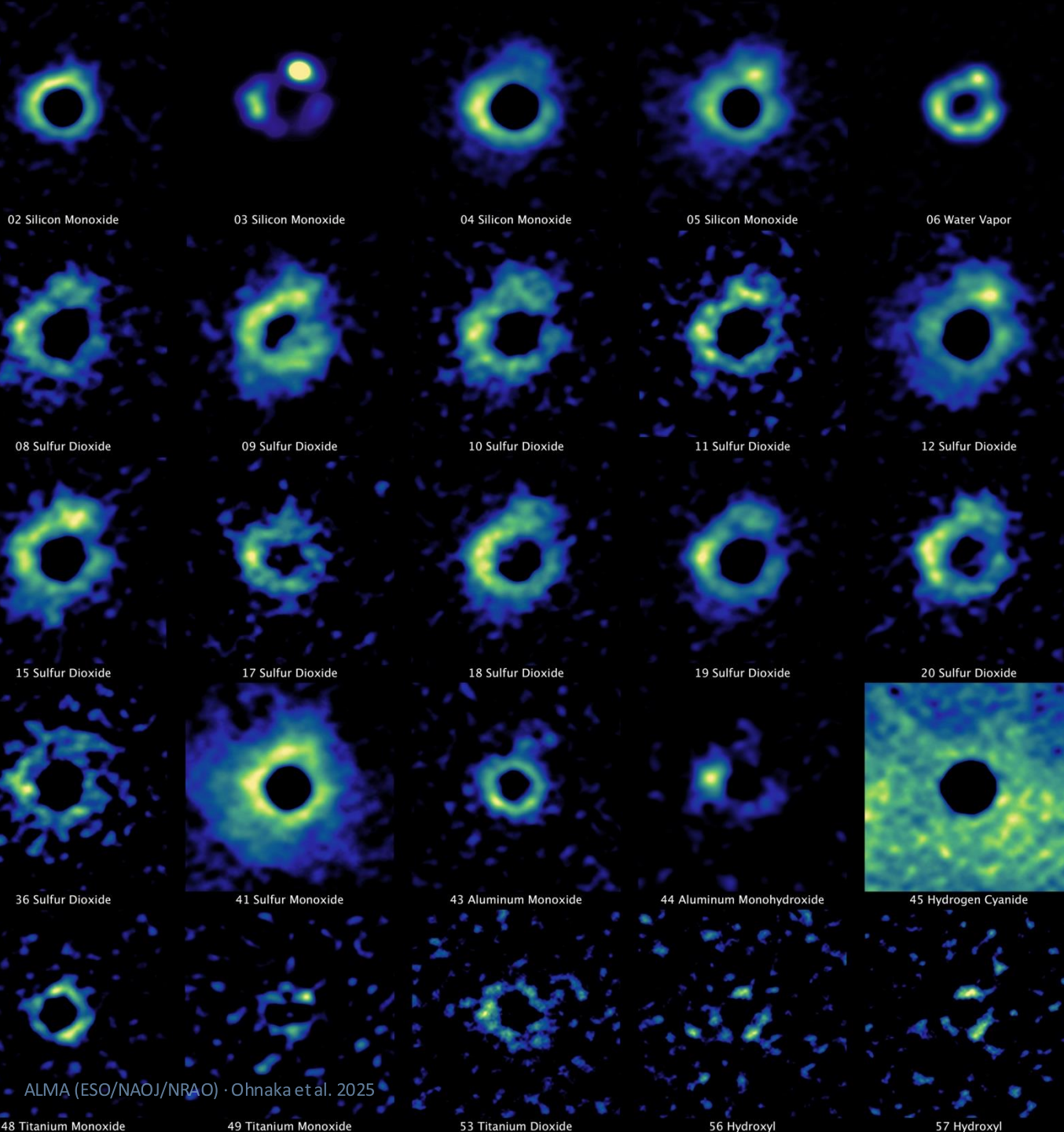

57 molecular views — simultaneously

ALMA captured 57 distinct spectral signatures simultaneously, each tracing a different layer of the star's atmosphere at different temperatures and distances from the surface.

Gas in motion — up and down at once

Gas close to the star's surface is being blown outward while material slightly higher up is simultaneously falling back in — a complex, layered flow not seen before at this resolution.

Watching dust being born

Observations taken just 9 days apart with ALMA and the VLT directly connect specific gas molecules to newly forming dust grains, showing the process as it unfolds.

Why it matters: W Hydrae is at a stage the Sun will reach in about five billion years. Studying how such stars shed their outer layers explains how dust and molecules are returned to the interstellar medium.

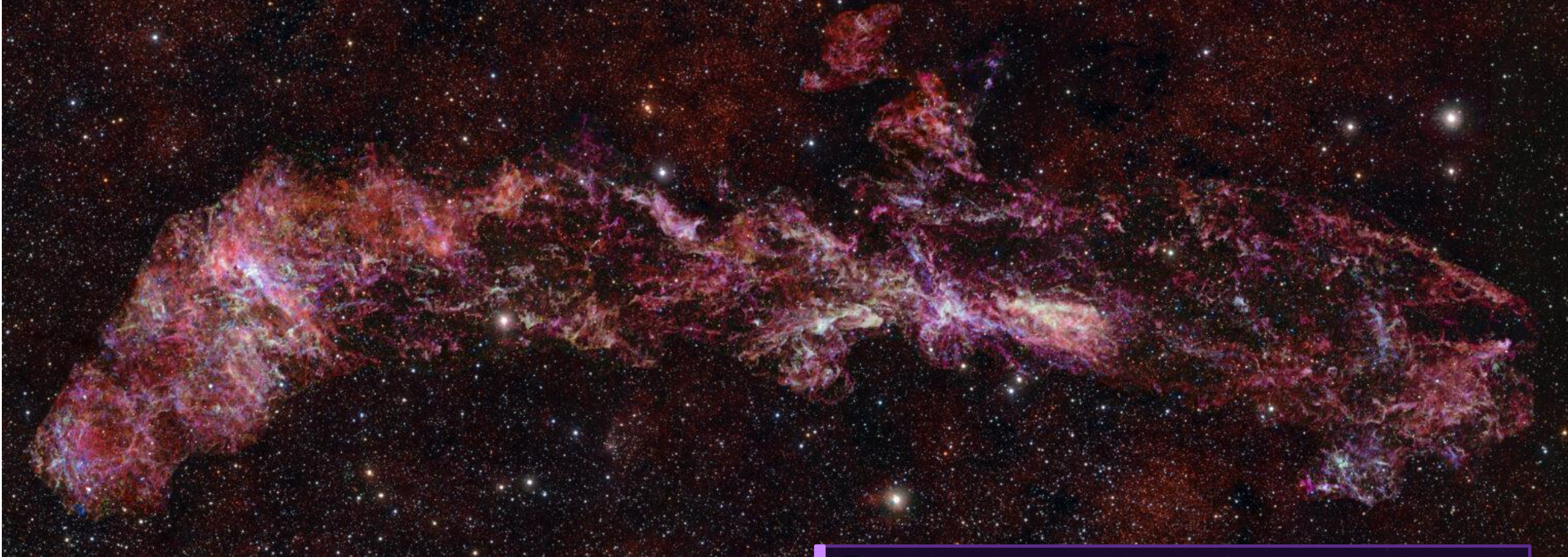

ALMA's View of The Heart of the Milky Way

Longmore et al (2026)

ALMA's most detailed image of the galactic center

A mosaic of 5,000+ pointings covering a region 3 times the width of the full Moon.

Hidden chemistry exposed

Dozens of molecules identified, from simple silicon monoxide to more complex compounds such as methanol and acetone, revealing the chemical richness of this region.

A laboratory for star formation in extreme conditions

ACES is being used to explore how feedback-driven energy and momentum are shaping the molecular clouds at the center of the Galaxy.

Pulses from the Galactic Center Magnetar PSR J1745-2900

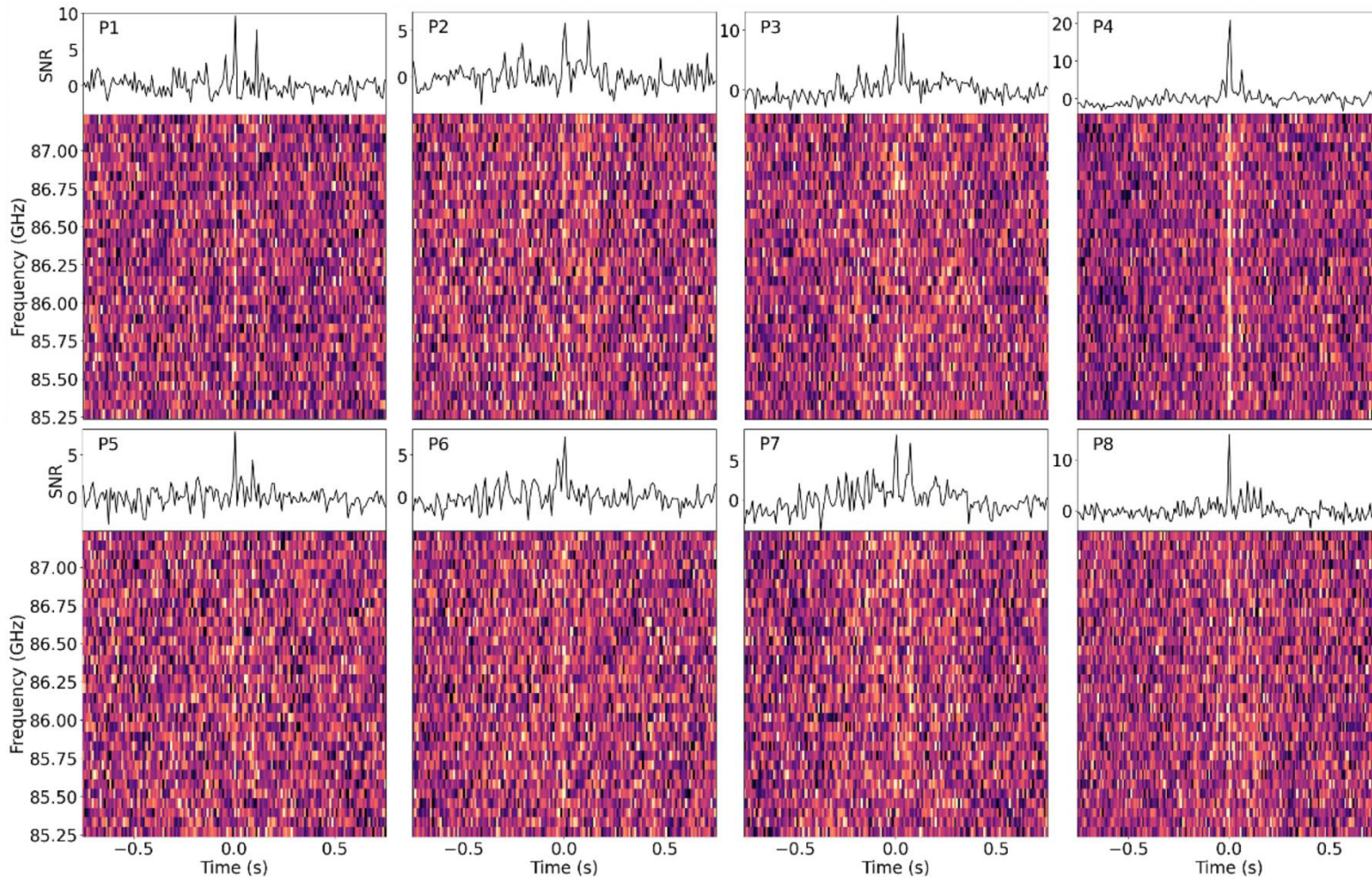

- Fast Radio Bursts (FRBs)
 - extremely brief, bright radio flashes
- Origins are unclear
 - magnetars at cosmological distances are a leading candidate
- Galactic Center
 - testbed to see if magnetars in dense environments can be seen by ALMA
- ALMA Discovery:
 - 8 pulses detected from magnetar PSR J1745-2900 in Band 3 (first time)
- Implications
 - ALMA could detect 160+ pulsars and multiple bursts per hour from repeating FRBs

Band 10 imaging in the [OI] 63 μ m line of lensed galaxies



[OI]63 continuum-subtracted integrated spectrum (yellow histogram) [CII] and [OI]145 overlaid

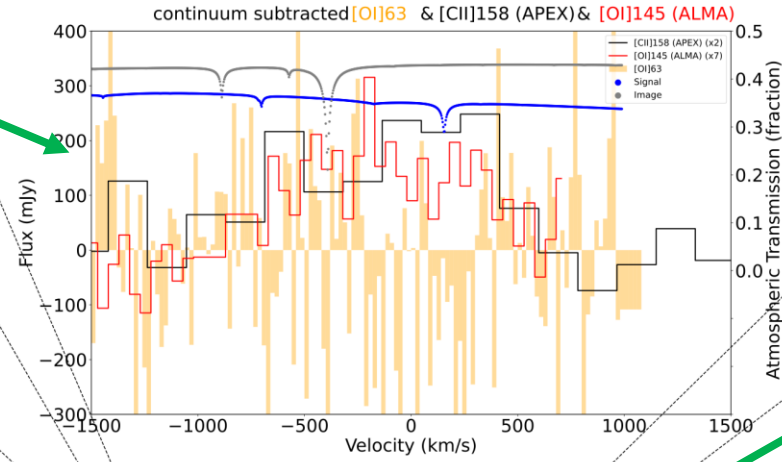

Band 10 continuum Band 7 contours overlaid

Small aperture [OI]63 extractions

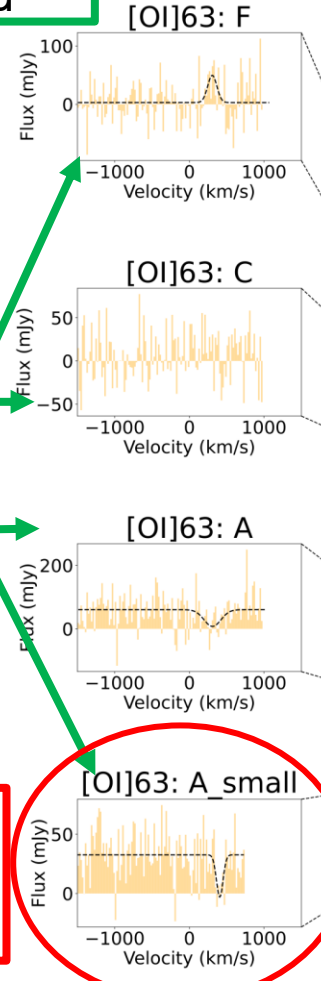

Small aperture [OI]63 extractions

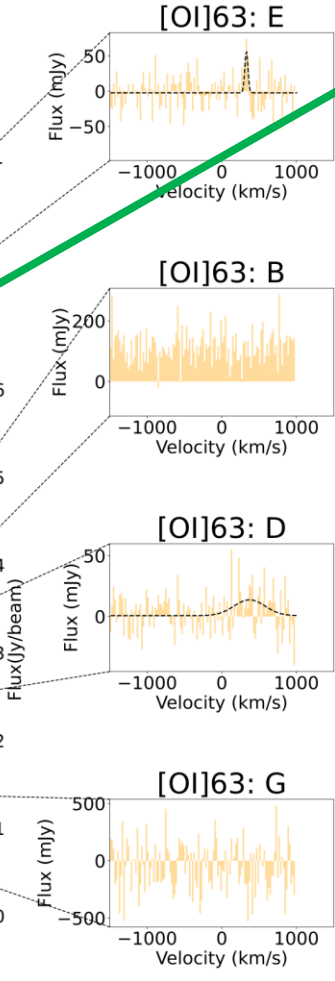

Narrow [OI] 63 μ m absorption against bright continuum source

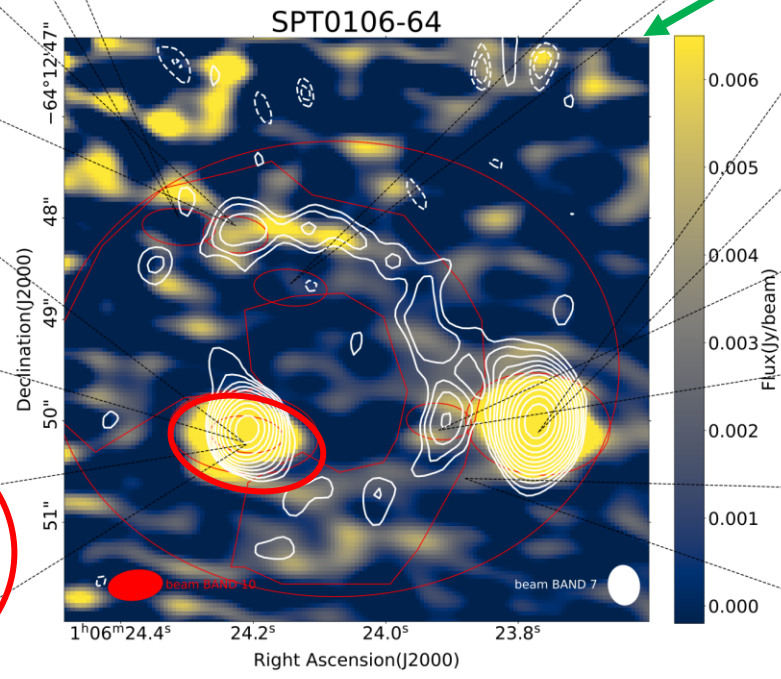

Detection of oxygen in galaxies when Universe was only 300 Myr old



Hashimoto et al. 2018 — Zavala et al. — 2024 Schouws et al. 2024 — Carniani et al. 2024

Redshift 14.2 (290 million years)

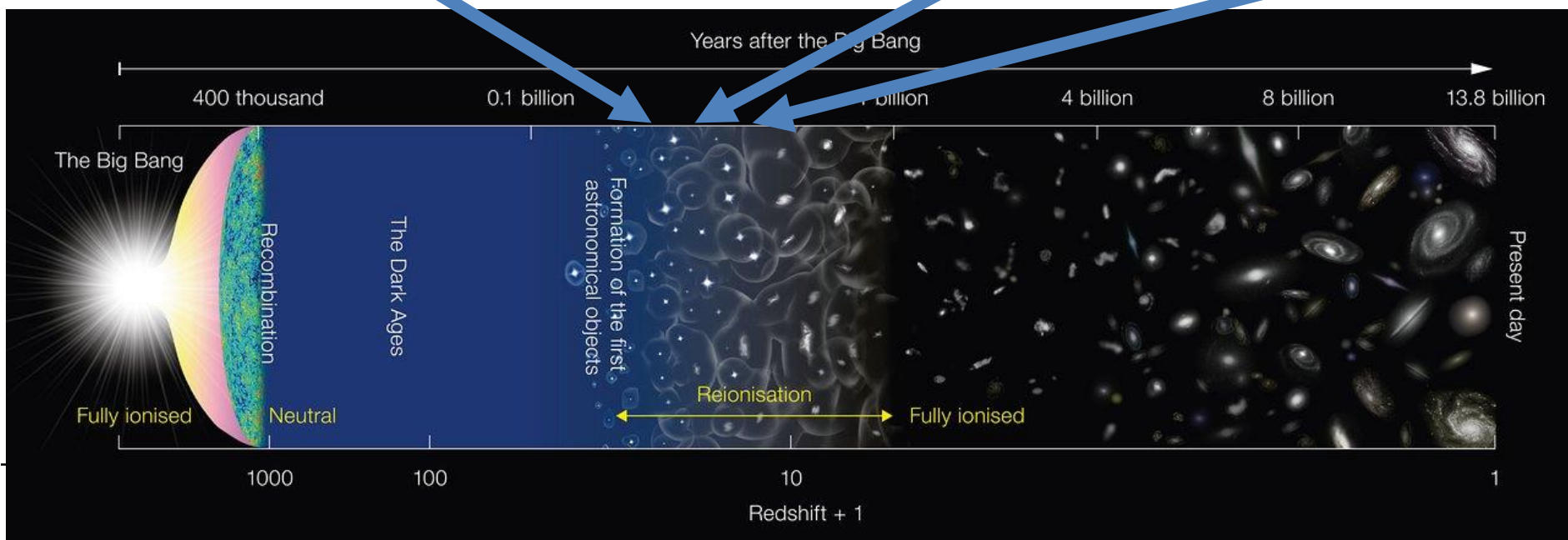
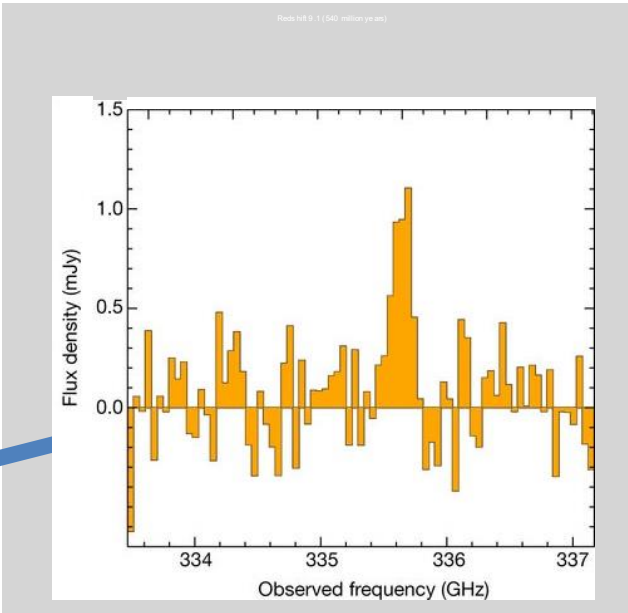
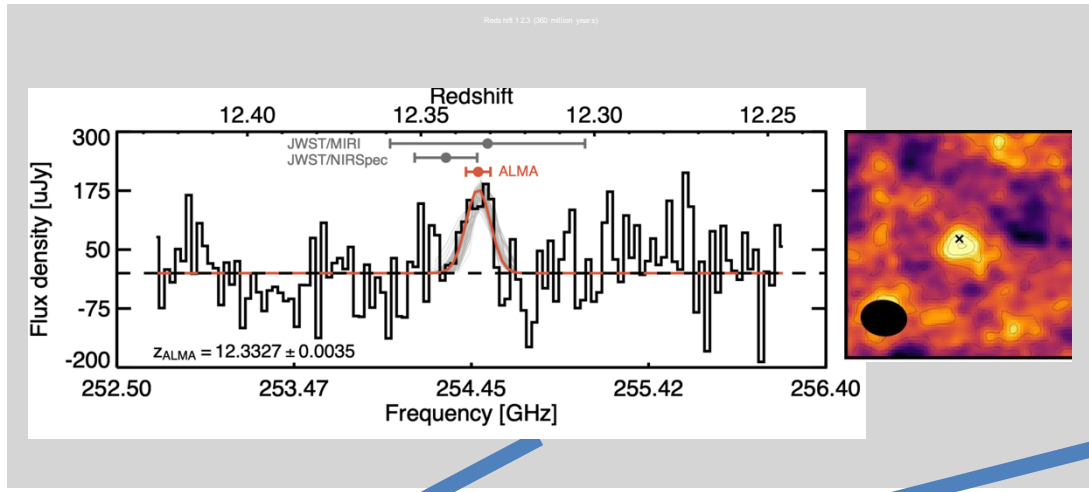
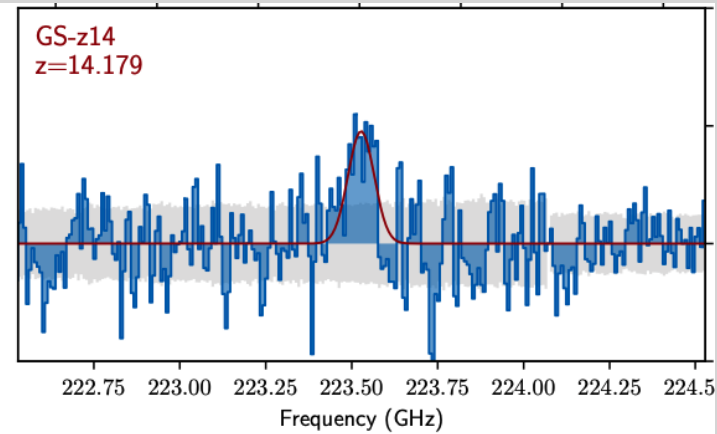

- JWST has surprisingly identified luminous galaxies at very high redshift.
- ALMA follow-up have now detected galaxies when universe was only 300 million years old.
- Demonstrates ALMA has an important role in exploring galaxies at the highest redshifts.



ALMA development

Keeping ALMA at the forefront of technology

ALMA in the 2030s: scientific drivers

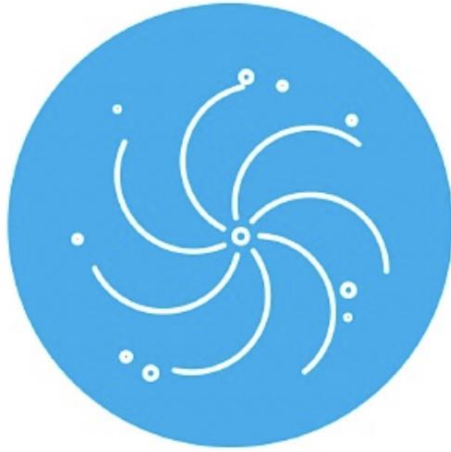

ORIGINS OF GALAXIES

Trace the cosmic evolution of key elements from the first galaxies ($z > 10$) through the peak of star formation ($z = 2-4$) by detecting their cooling lines, both atomic ([CII], [OIII]) and molecular (CO), and dust continuum, at a rate of 1-2 galaxies per hour.

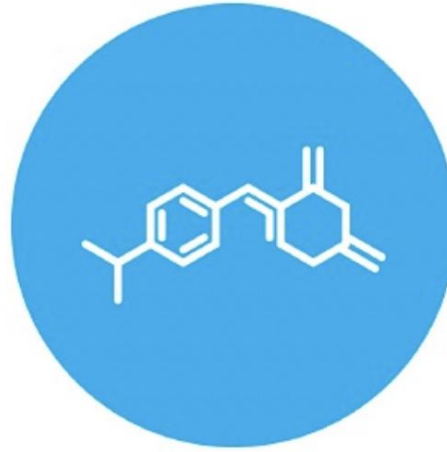

ORIGINS OF CHEMICAL COMPLEXITY

Trace the evolution from simple to complex organic molecules through the process of star and planet formation down to solar system scales ($\sim 10-100$ au) by performing full-band frequency scans at a rate of 2-4 protostars per day.

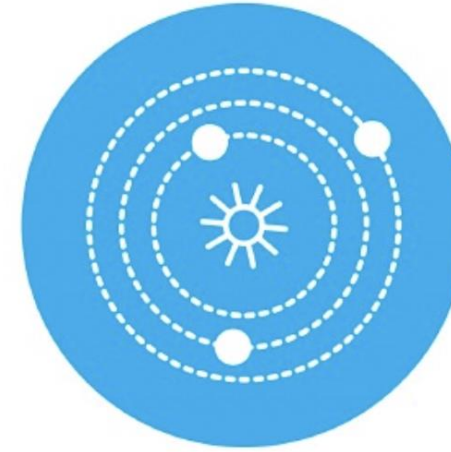

ORIGINS OF PLANETS

Image protoplanetary disks in nearby (150 pc) star formation regions to resolve the Earth forming zone (~ 1 au) in the dust continuum at wavelengths shorter than 1mm, enabling detection of the tidal gaps and inner holes created by planets undergoing formation.

<https://www.almaobservatory.org/en/publications/the-alma-development-roadmap>

ALMA Wideband Sensitivity Upgrade (WSU) scope



Implementing the ALMA2030 roadmap

The scope of the WSU Program is to:

- Upgrade the signal chain, software and science operations processes **for a 4x system bandwidth**
- With upgrades of Bands 6, **Band 7** and Band 8 (*0.6 to 1.4 mm*), in addition to **Band 2** (*2.5-4.5 mm*) being installed currently
- To offer at least the observing modes currently offered

Other receiver bands (e.g. Band 4+5, **Band 9** and 10) will be upgraded outside the scope of the WSU Program, as part of the ALMA Development Program.

ALMA elements to be upgraded during WSU

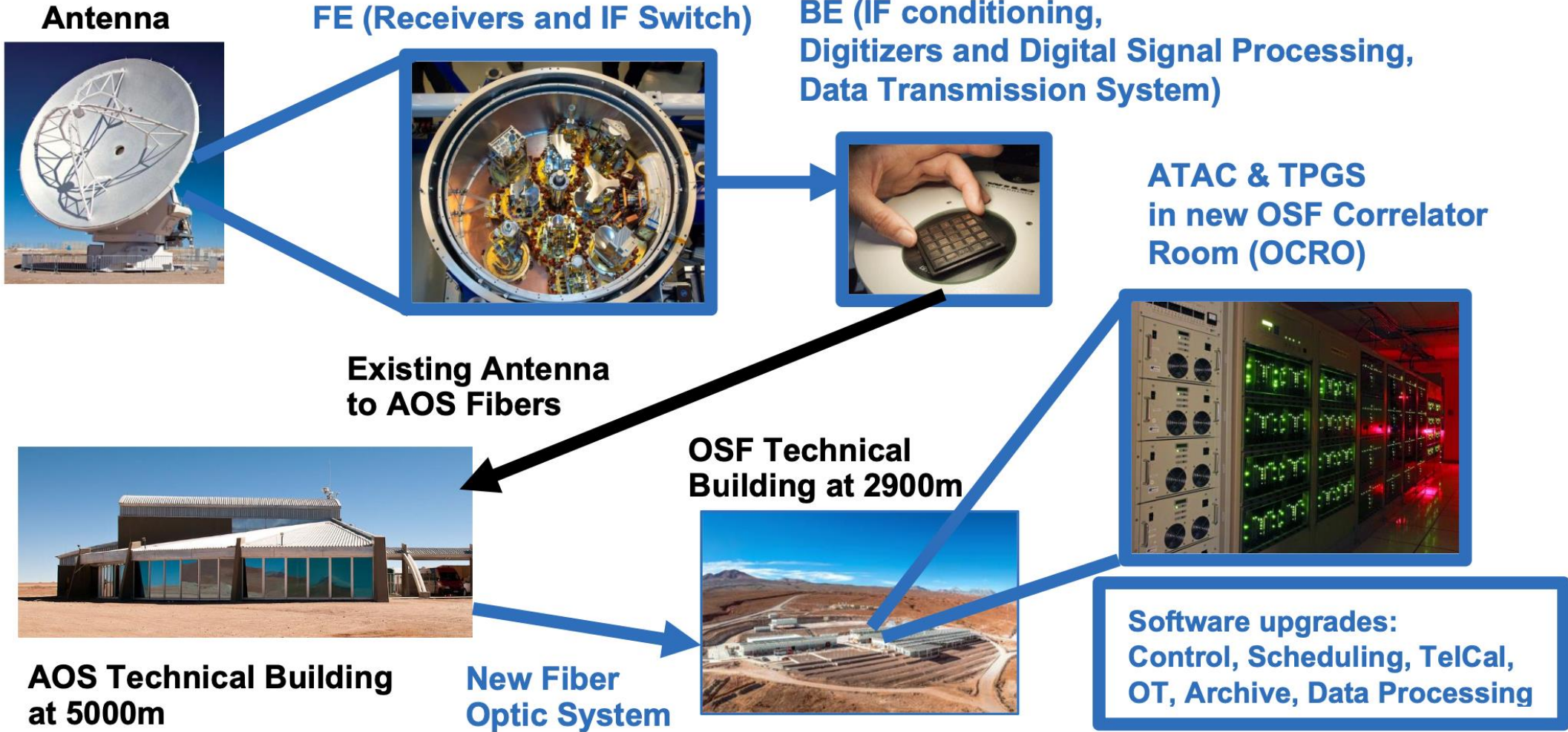

Wideband IF processor, a key WSU component



- The WSU requires an upgrade of the antenna receivers and associated electronics and correlators to process the entire bandwidth.
- **The Wideband IF Processor (WIFP) is an element critical to the success of WSU, as it provides:**
 - wideband sampling (2-20GHz)
 - high quantization efficiency
 - time-stamping of the data, enabling asynchronous operations
- WIFP is an ESO-lead project in cooperation with LAB (Bordeaux)

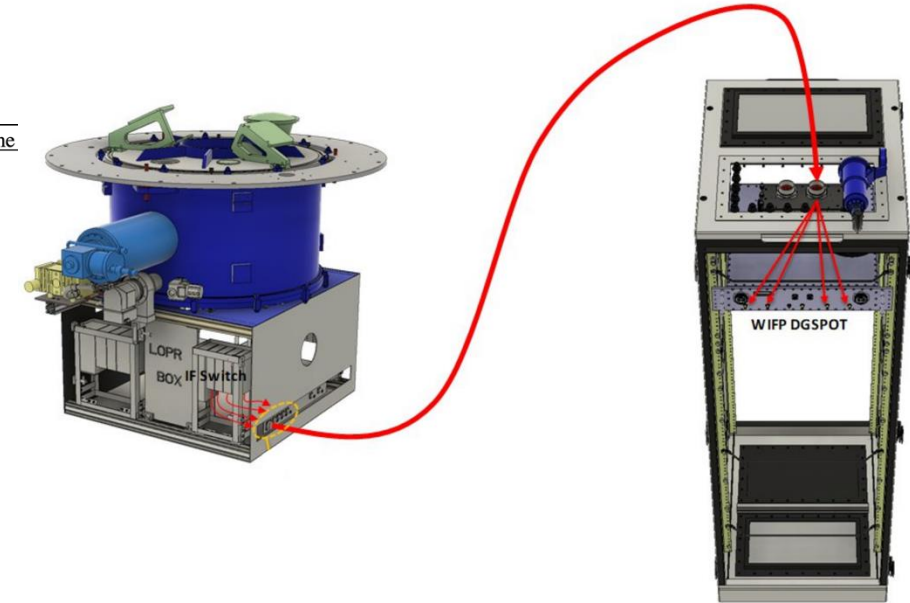
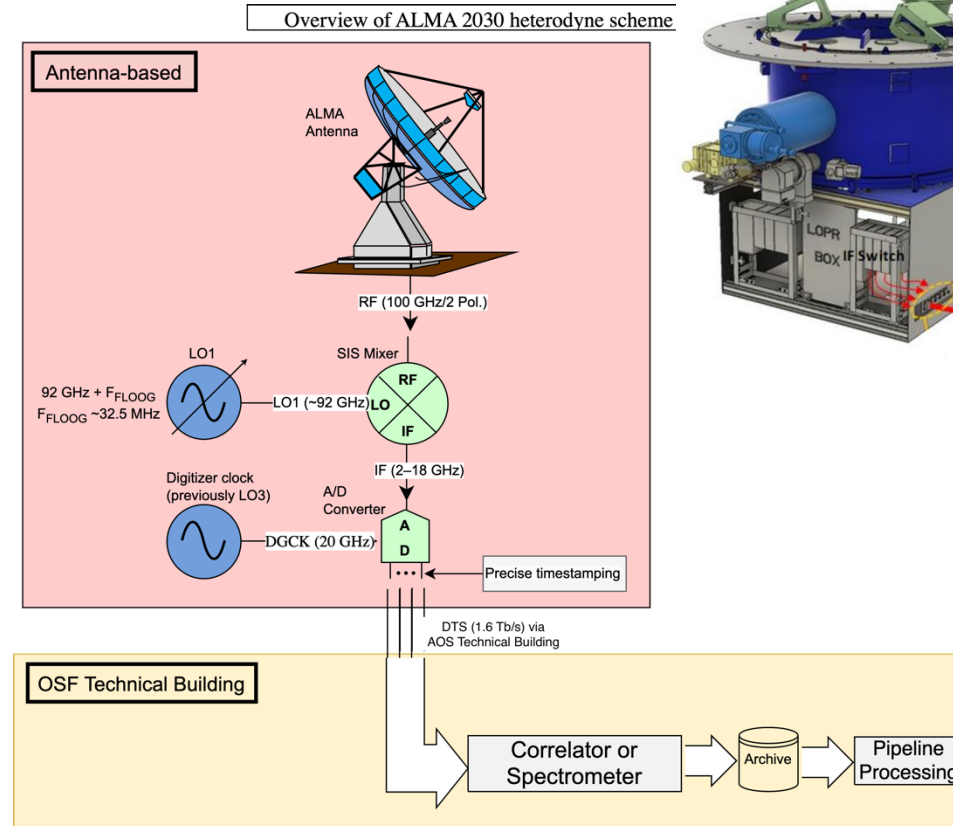

Band 2: the first WSU-ready receiver, built in Europe

- In development since 2012, first light 2023, science verification 2025, first PI offering in 2026
- Last construction band → first Wideband Sensitivity Upgrade (WSU) band
- Built by consortium of 9 institutes, including GARD/Chalmers SE
- Covering the 67 to 116 GHz (i.e. Band 2 and full range of current Band 3)
- Covering IF bandwidth from 2 to 18 GHz, i.e. 4x current Band 3
- Improved receiver sensitivity 80% of $T_{RX} < 30$ K (67–90 GHz), < 41 K (90-116 GHz)



ALMA Front End and cold cartridges inside cryostat

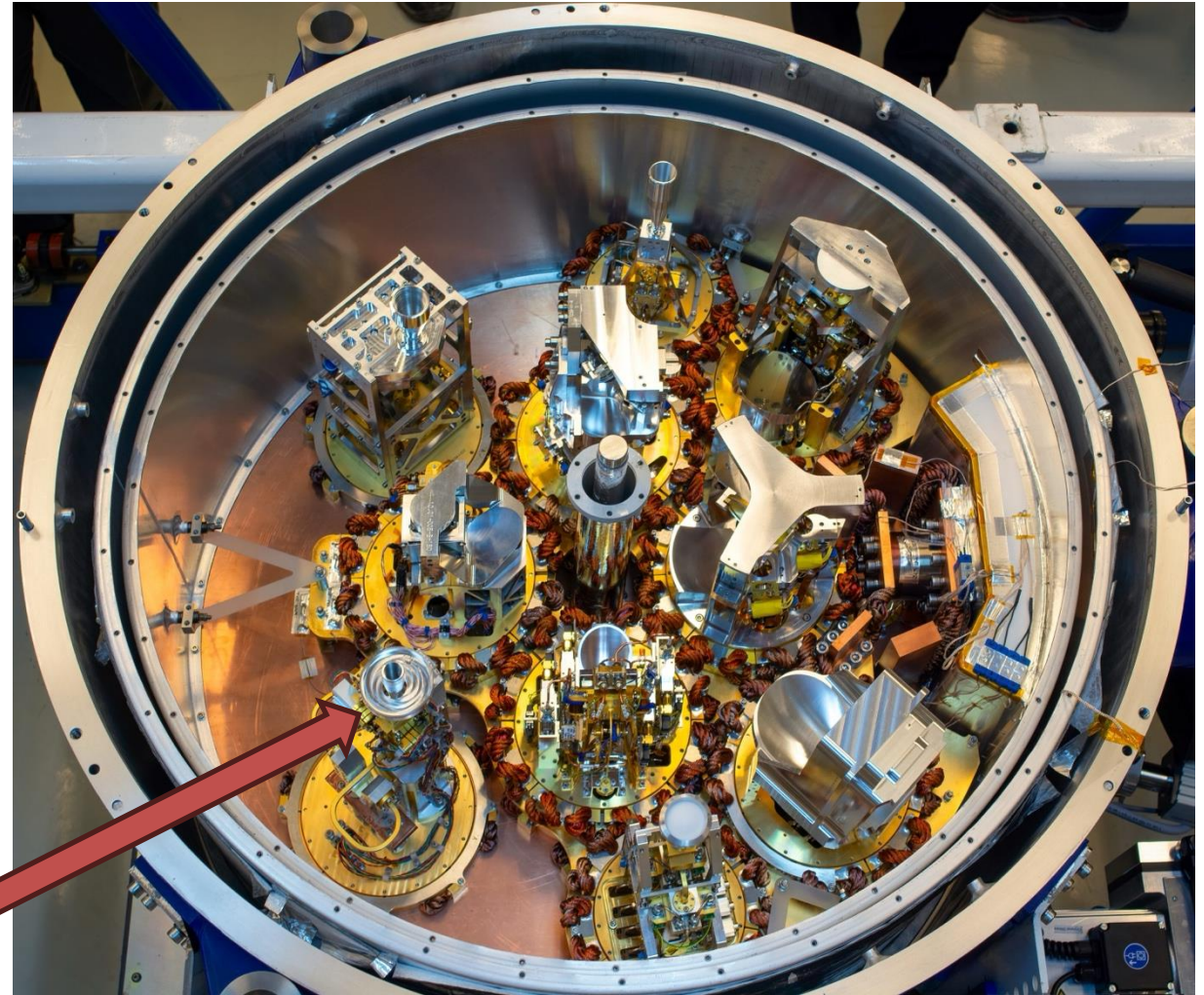

Band 2 cartridge

Band 2 frequency coverage in context

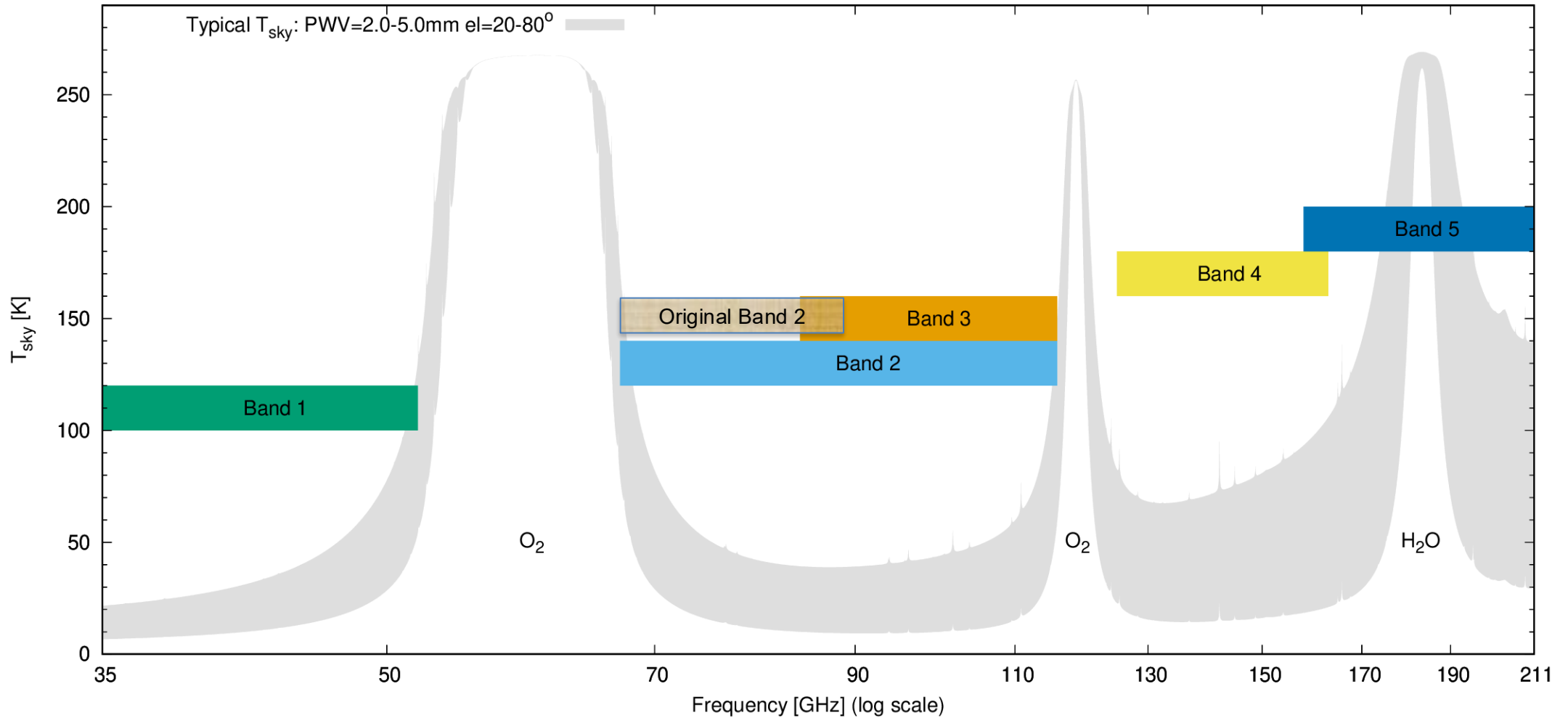

Band 2 receiver noise

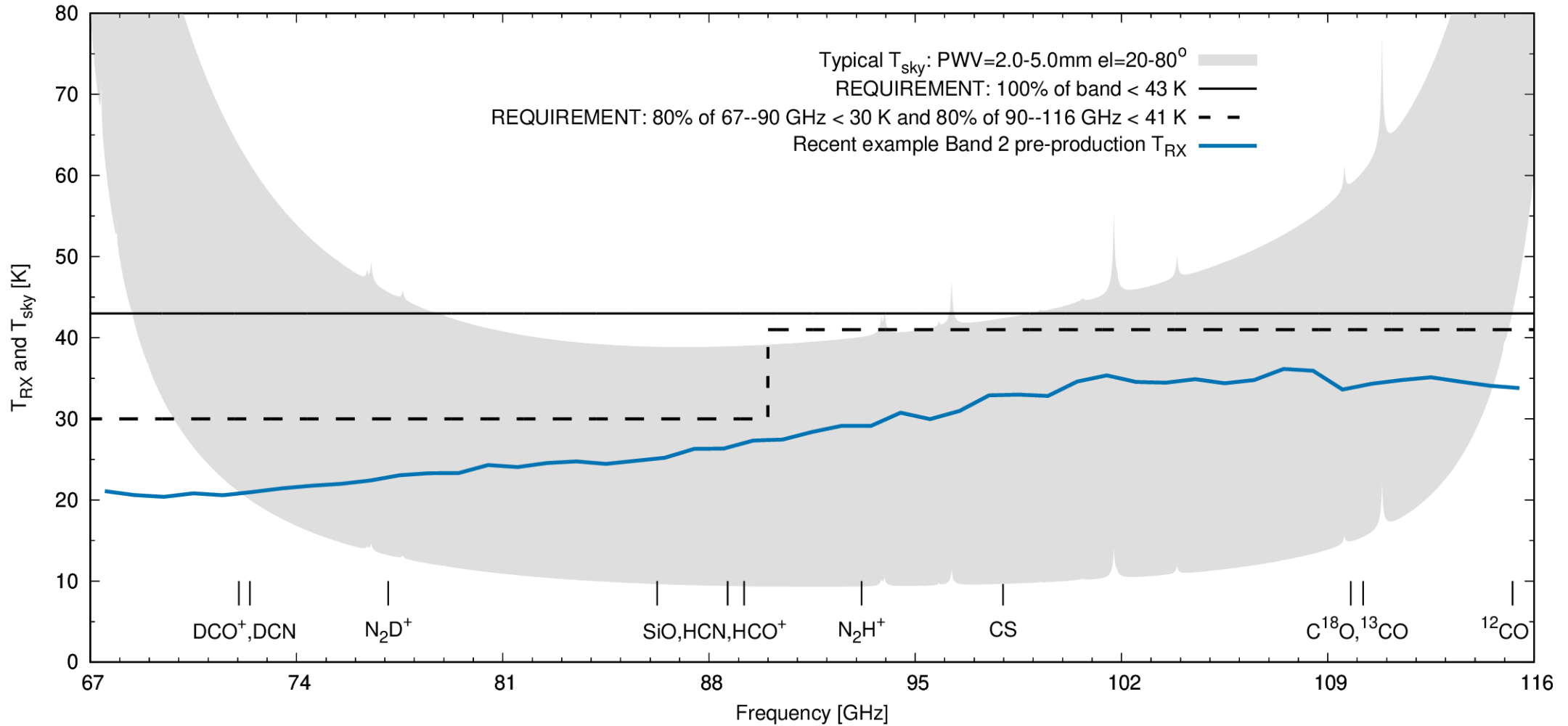

Tuning flexibility: current system and wide LO

Future

Present

Past

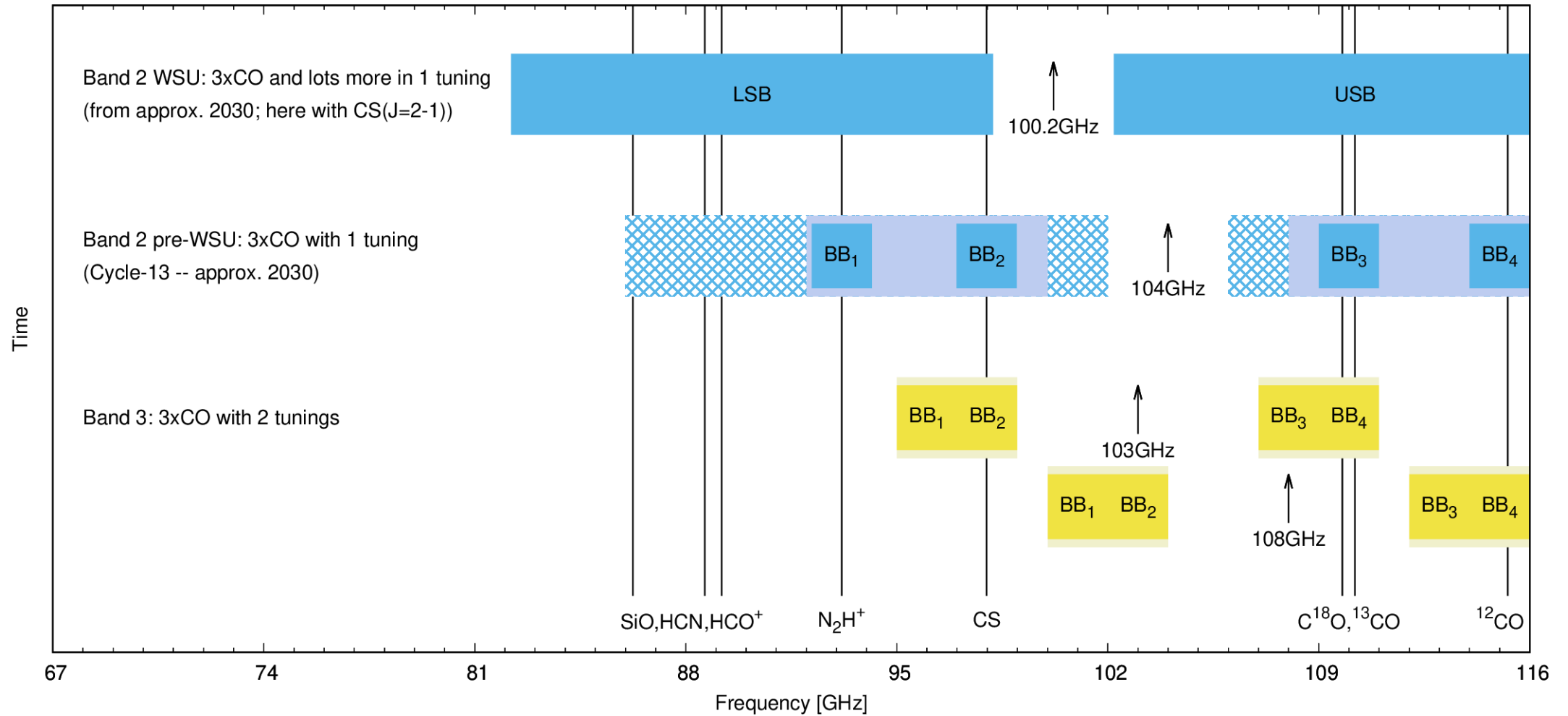

Efficient spectral scans with 1.875GHz SpWs



Placing all 4 BBs in one sideband allows spectral scans with uniform coverage

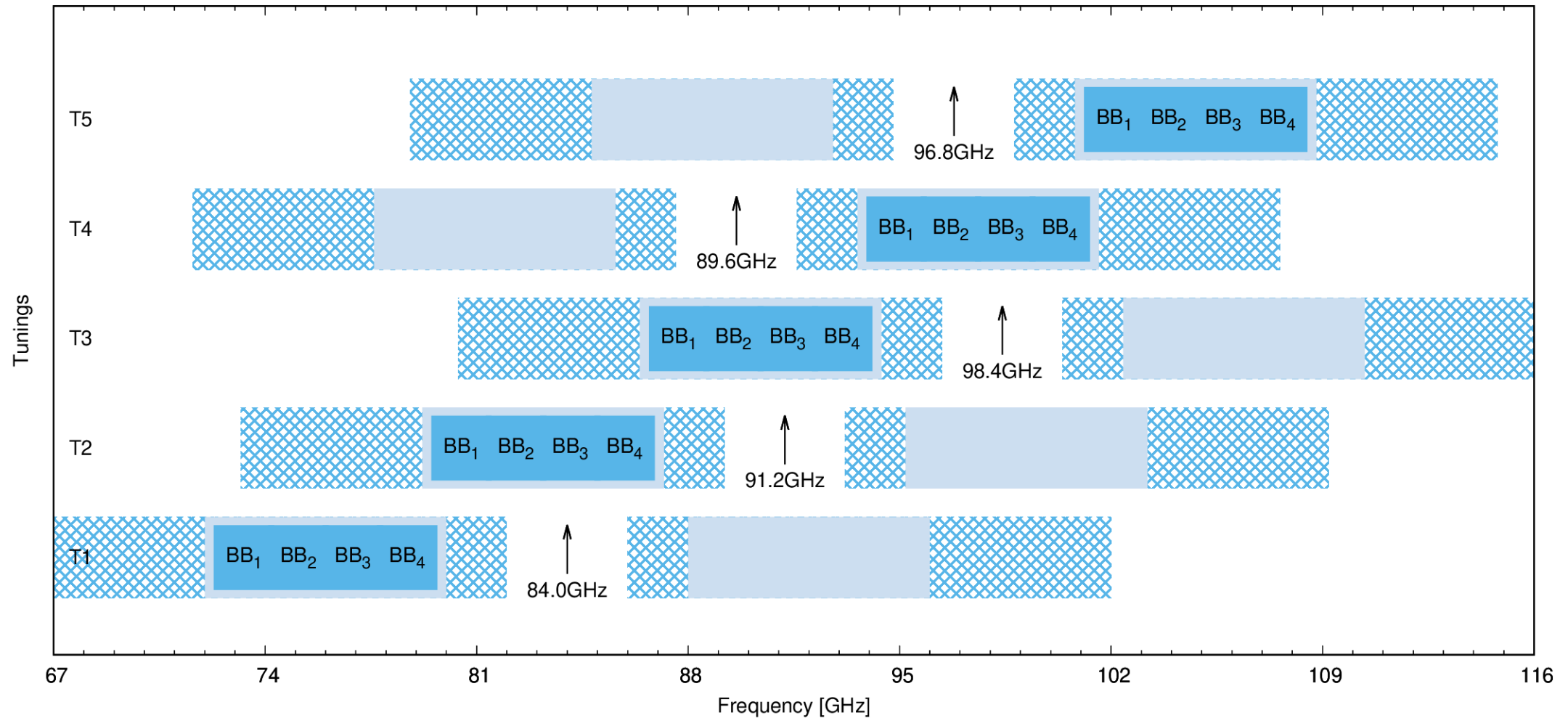

Band 2 science verification: spectral scan of SPT0027-50

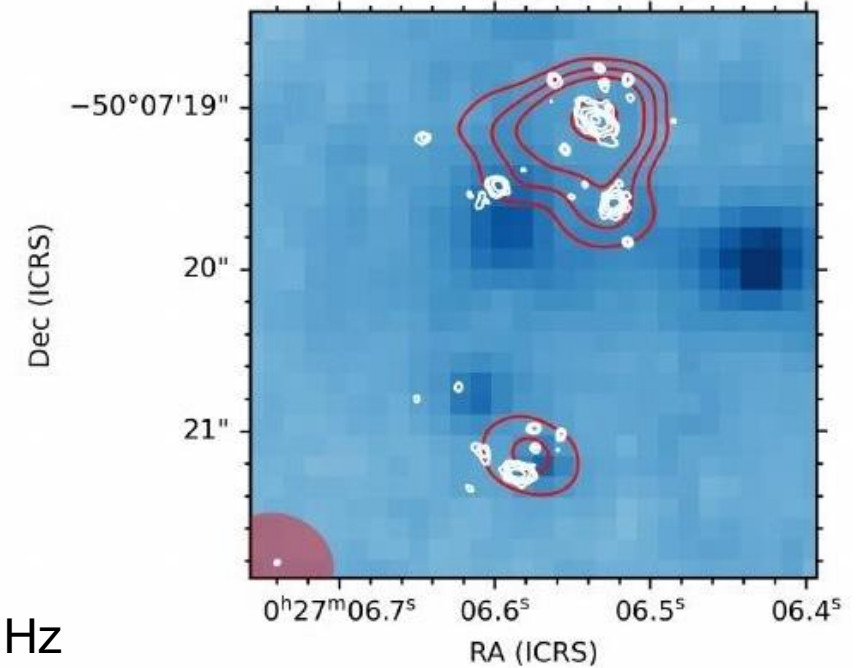
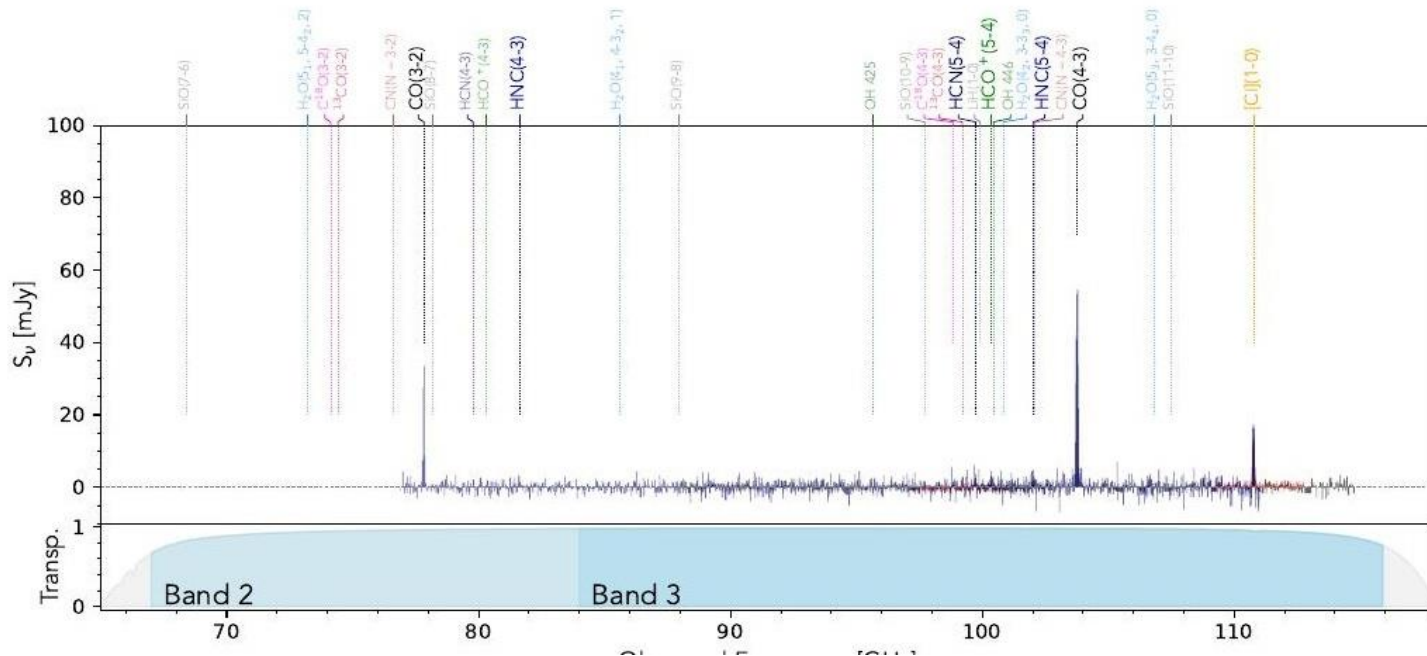

- Spectral scan using 4 tunings providing continuous coverage 77 to 111 GHz
- First Band 2 paper published by Bakx et al. 2026 SE
- Already now, Band 2 is more efficient than previous band 3 to determine redshifts
- Prospects are very bright to use ALMA as a redshift machine in the WSU era!



Further ALMA development

European ALMA development studies



- ALMA has a dedicated development budget to implement a wide range of possible upgrades of systems and procedures
- New ideas often start as studies, many of whom are later implemented as projects
- All ALMA partners run a study programme, ESO does this with a 3-year cycle of Calls for Proposals (CfP)
- ESO development studies are open to all ESO member state institutes
- Next call expected to be released in 2028, contact cdebreuc@eso.org for details
- Sweden is a very active participant, also an ongoing Danish study, thus far none from Finland yet...

ALMA development studies (1/2)



PI (institute)	Title
Baryshev (NOVA)	ALMA Digital Front-End
Belitsky (GARD) ^{SE}	ALMA Band 6+7 Cold Cartridge Demonstrator
Belitsky (GARD) ^{SE}	Advanced waveguide components & technologies for 2SB dual polarization receiver cartridges
Boussaha (Paris)	Technological developments towards the ALMA Band 9v2 SIS mixers
Fuller (Manchester)	InP MMIC LNAs for ALMA Band 2+3: Pushing the noise limit
Hesper (NOVA)	Improving Band 9 sensitivity by Advanced Tuning Algorithms
Hesper (NOVA)	Towards a producible ALMA2030-ready Band 9 CCA
Gallejo (Yebes)	MMIC based wideband Low Noise Amplifiers
George (Manchester)	TASER: Towards ALMA System on Chip European Receivers
Gueth (IRAM)	Feasibility Study for an ALMA Band 7 Upgrade
Pavolotsky (GARD) ^{SE}	SIS Process Development to serve next Generation Receivers for ALMA
Quertier (Bordeaux)	Upgrading the ALMA Digital System, from Digitization to Correlation
Villa (INAF)	Optimization and Production Engineering of Band 2+3 Passive Components

ALMA development studies (2/2)



PI (institute)	Title
Bárta (CAS)	Towards High-resolution Solar ALMA Images
Bridger (STFC)	The Evolution of ALMA Proposal and Evaluation Preparation
Hess (OSO) <small>SE</small>	Prototype ALMA Spectral Line ADP Pipeline
Magdis (DTU) <small>DK</small>	Scientific opportunities and technical considerations of focal plane arrays
Maerker (OSO) <small>SE</small>	High Cadence Imaging of the Sun
Massardi (INAF)	The ALMA Re-Imaging Development Study
Pardo (IFF)	Improved and tested Atmospheric Model above 300 GHz.
Wijnholds (Astron)	Streaming Visibility Processing for ALMA

See <https://www.eso.org/sci/facilities/alma/development-studies.htm>

Sub/mm astronomy beyond the 2030s



Community-driven initiatives towards the next-generation sub/mm facility

AtLAST: 50m telescope with 2-degree field of view

ALMA2040: substantial increase in collecting area

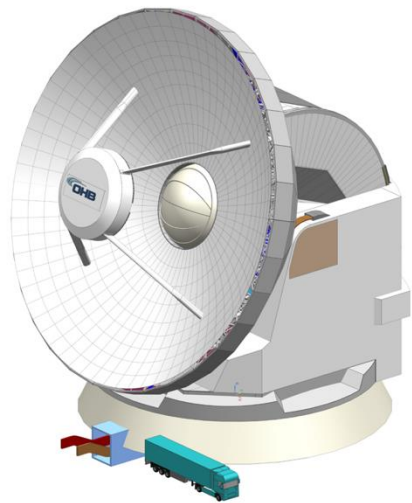

Where are all the baryons?

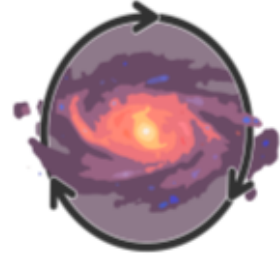

How do structures interact with their environments?
What does the time-varying submm Universe look like?



ALMA2040 Key Science Drivers

<p>The life cycle of planetary systems & stars <i>Including the formation of rocky planets down to ~AU scales</i></p>	<p>The formation and evolution of structure <i>Including primordial galaxies and black holes out to z~20</i></p>	<p>Evolution of the cosmic baryon cycle <i>Including dust & the development of chemical complexity that leads to life</i></p>	<p>Cosmic explosions and acceleration <i>Including multi-messenger astronomy in the 2040s</i></p>
--------------------------------------------------------------------------------------------------------------------------------------	-----------------------------------------------------------------------------------------------------------------------------	----------------------------------------------------------------------------------------------------------------------------------------------	--------------------------------------------------------------------------------------------------------------

FORESEEN CAPABILITIES:

- > 5-10x line sensitivity
- > 3x angular resolution
- Simultaneous multi-band observing
- On-the-fly calibration

ALMA 2040
THE NEXT-GENERATION (SUB-)MILLIMETER INTERFEROMETER

Learn more / join the effort:

Make ESO part of your career!



ESO logo

Road to the stars

A unique opportunity to conduct part of your PhD research at the European Southern Observatory

#ESOJOBS
eso.org/studentship

ESO Headquarters, Garching near Munich, Germany
ESO Vitacura, Santiago, Chile

Application deadline: 30 April and 30 October, each year



Fast-track Your Scientific Career

Research Fellowships in Germany or Chile

eso.org/fellowship
Deadline: 1 October

Steer your research
Collaborate with key scientists
Exchange ideas





ESO logo

European Southern Observatory

Observational and theoretical astrophysics, simulations and modelling, astrobiology, Solar System, exoplanets, astroparticle physics, planet and star formation, stellar structure, stellar populations, galaxies, galaxy clusters, galaxy evolution, and more.

Thank you!

Carlos De Breuck
cdebreuc@eso.oorg

-  @ESO Astronomy
-  @esoastronomy
-  @ESO
-  european-southern-observatory
-  @ESOobservatory

