



UNIVERSITY OF
MICHIGAN

<https://arxiv.org/abs/2504.10448>

A High-Precision, Fast, Robust, and Cost-Effective Muon Detector for FCC-ee

Linnuo Zhang

The University of Michigan

Groups expressed interest:

Michigan, MSU, UMass, Harvard, Tufts, UCI, SLAC, INFN Roma 1,
Fermilab, BNL, and U. Washington

Muon system in colliding beam experiments

FCC-ee detector concept

ALLEGRO

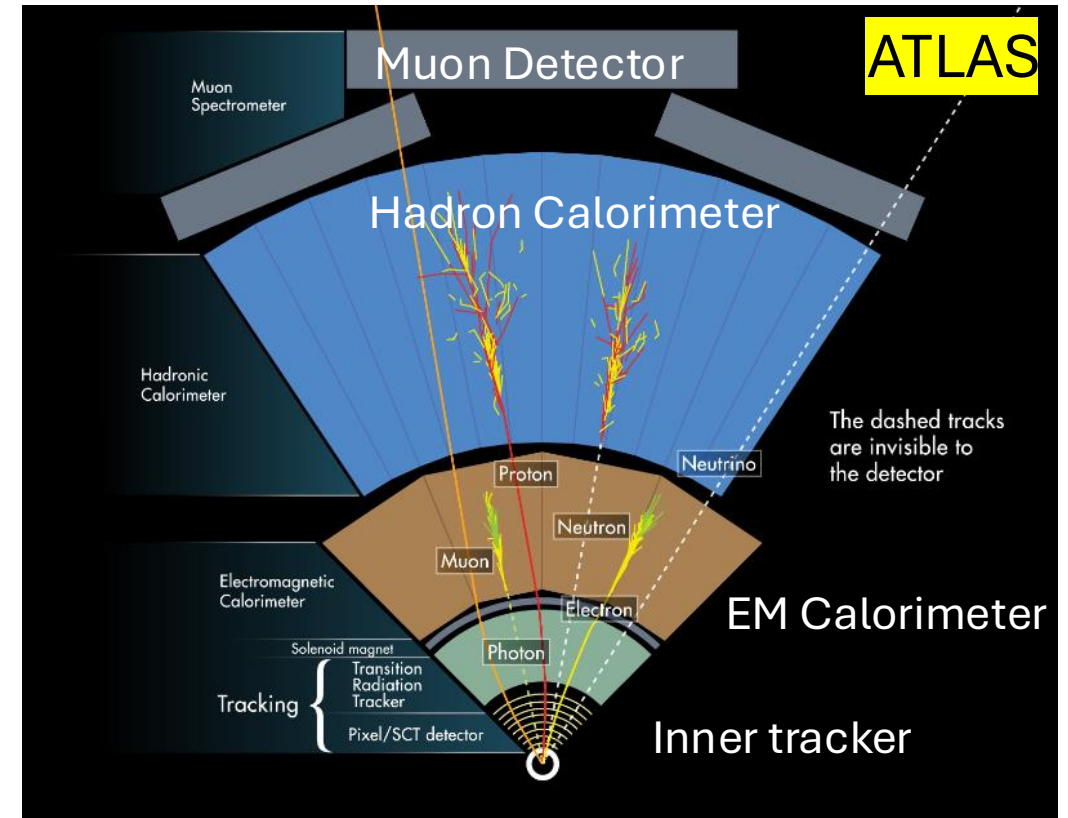
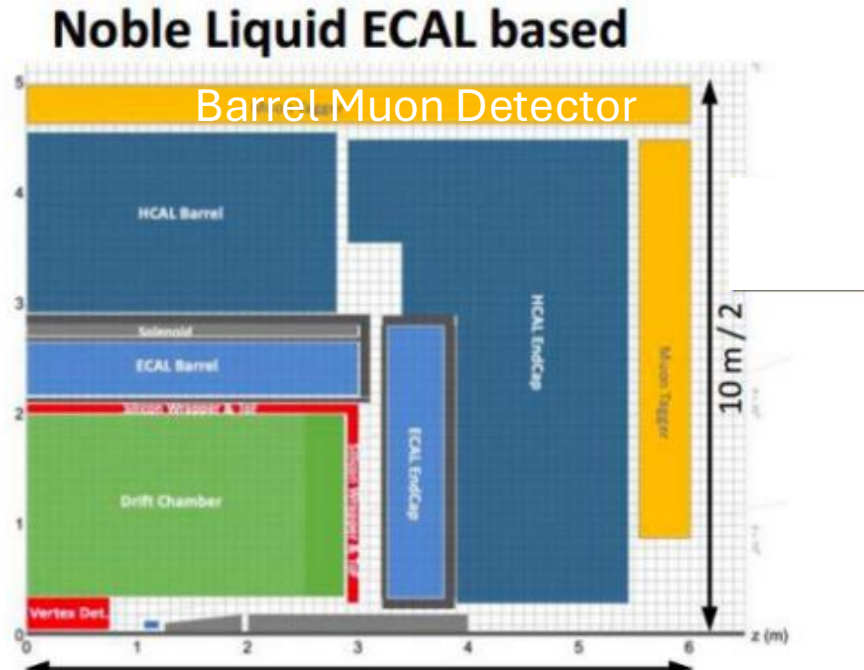

Muon identification (tagging) and independent triggering

- Tracking system, the outmost part of a detector (large volume)
- Identify events with hadronic particle punch through

Building for discovery

- Reconstruction of decay vertices of long-lived particles
- Time-of-flight information for detecting charged massive stable particles

Muons – Principal signal for discovery

Higgs boson discovery
80% detected $H \rightarrow 4l$
events contains μ

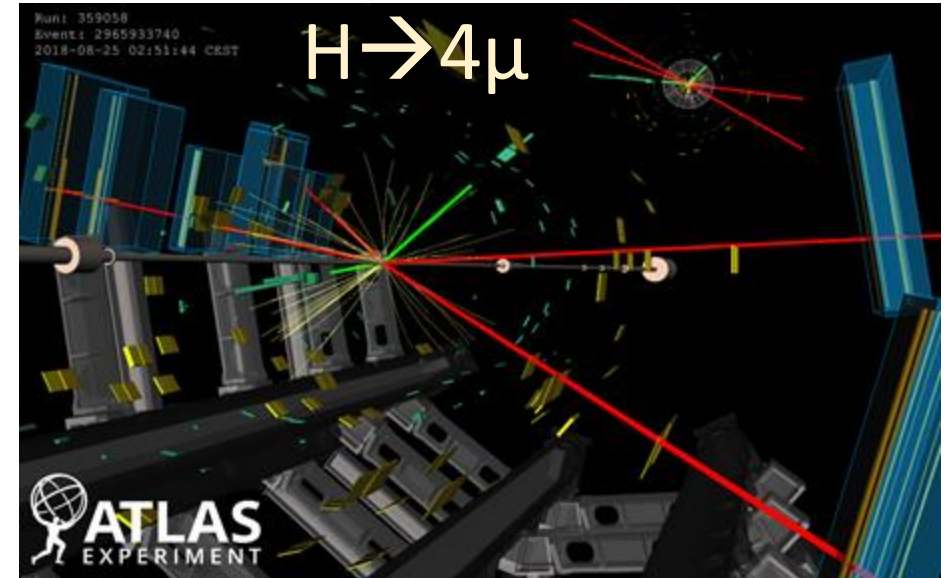
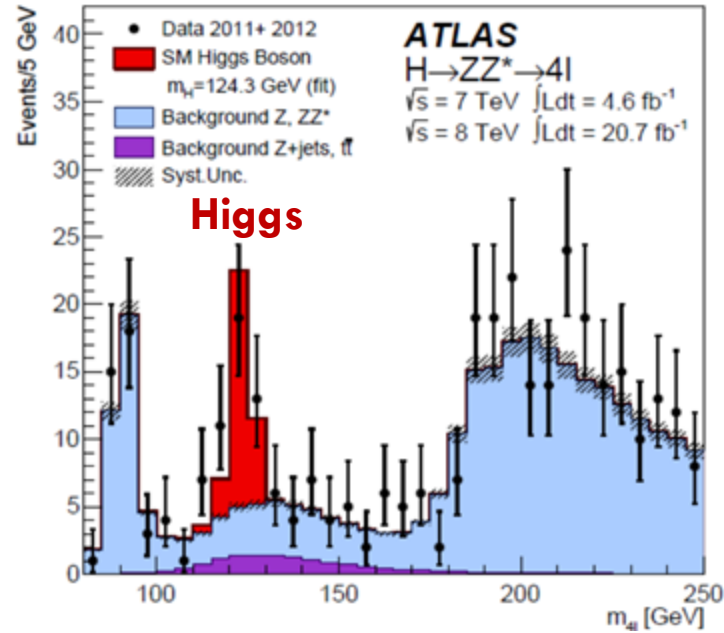

Search for new particles

Measure prompt and **non-prompt** particles:
Muon, electron, tau, photon, jets

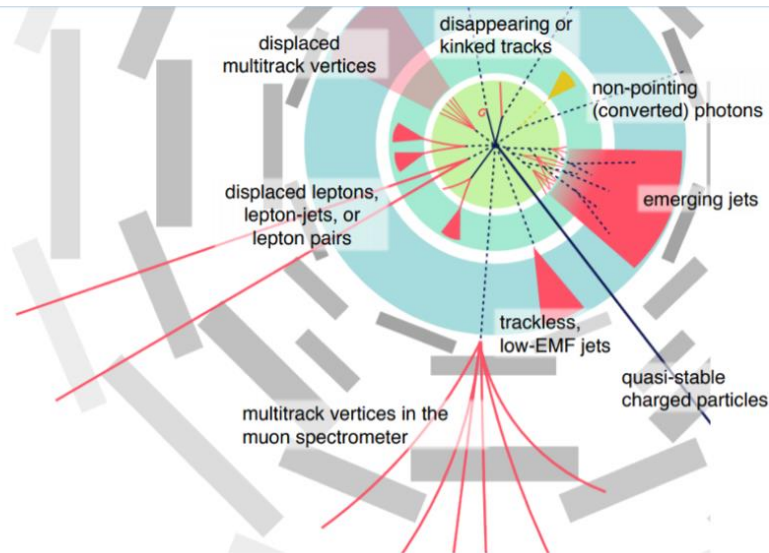

Count $Z \rightarrow \mu\mu$
Lumi monitor
→ More precise than counting $Z \rightarrow ee$

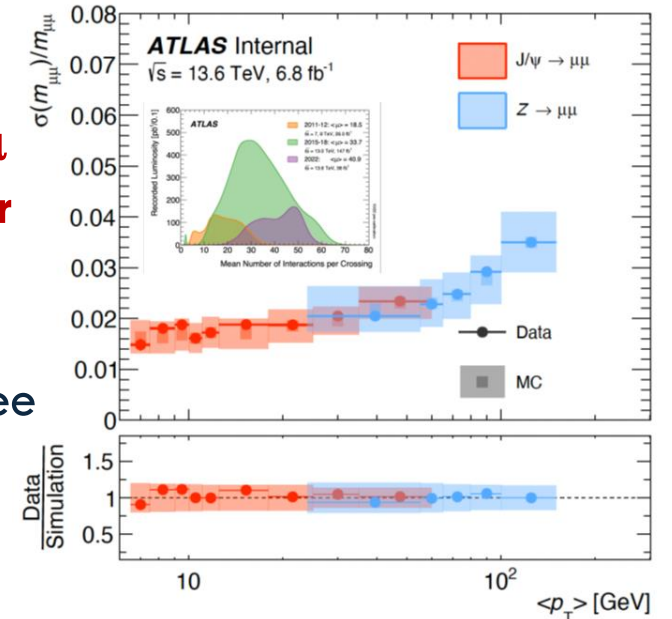

Long-lived particles are challenging to detect, due to their feeble interactions and unconventional decay signatures. **Conversely, large muon detector offer exciting opportunities for discovery.**

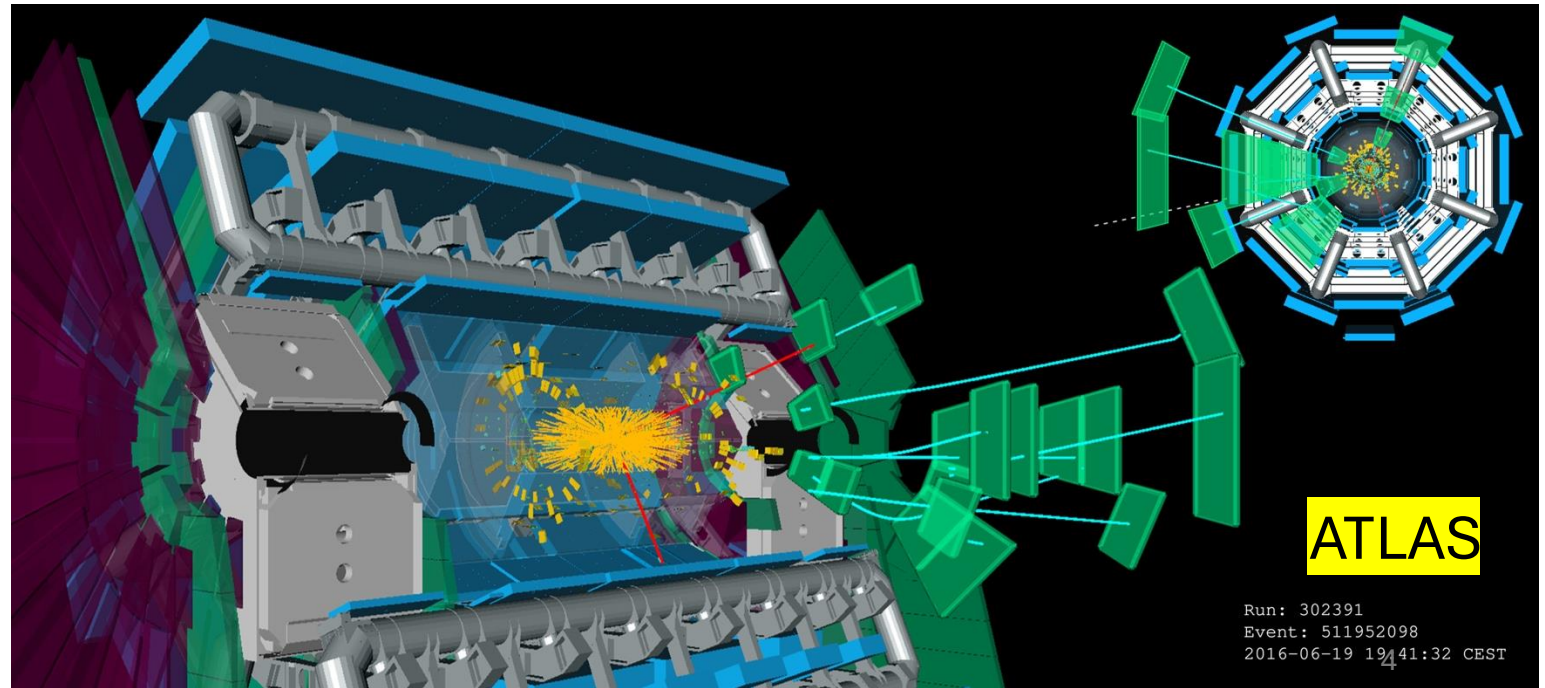
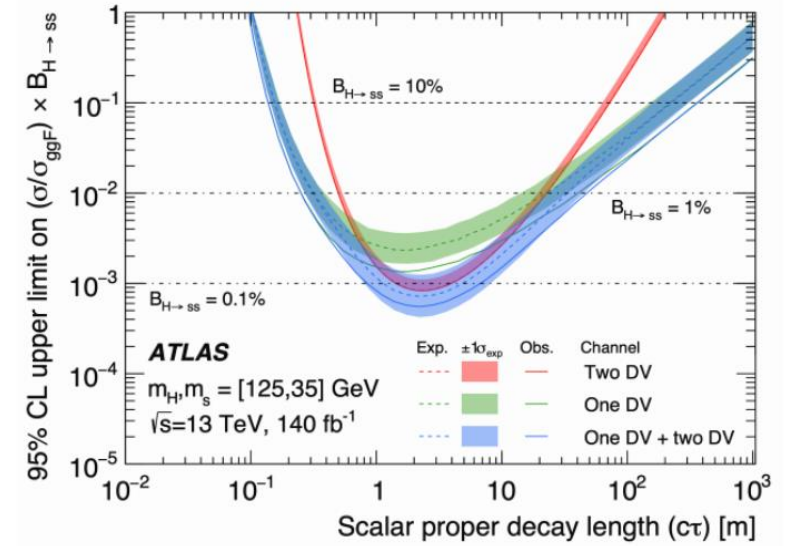
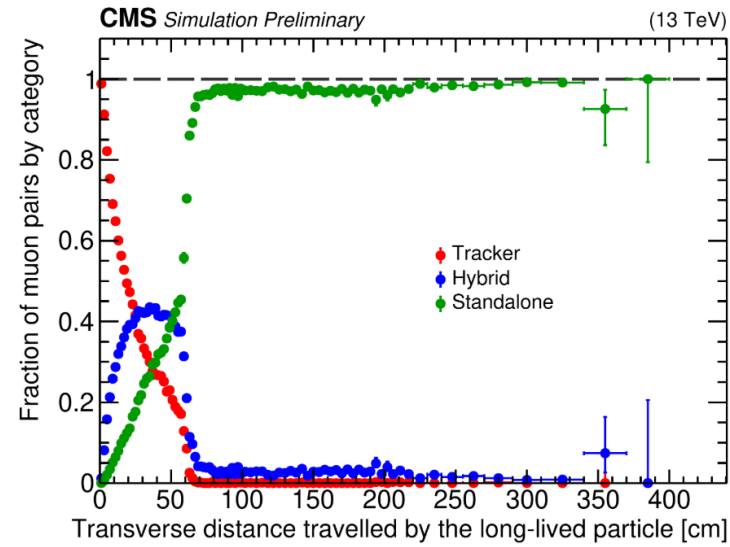
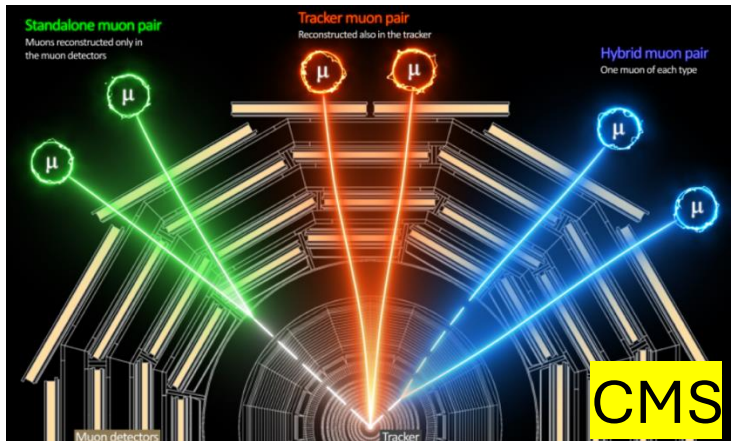
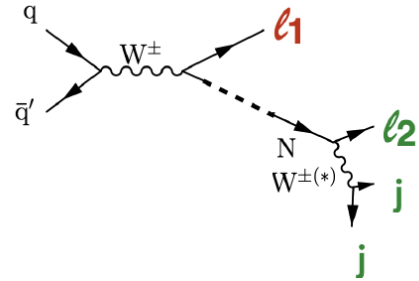
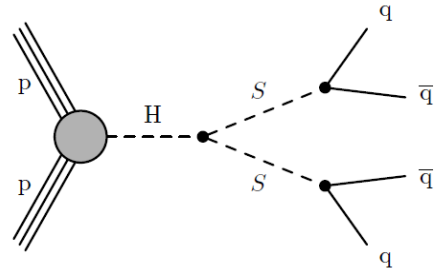

Run: 302391
Event: 511952098
2016-06-19 19:41:32 CEST

Muon detector proposal

IDEA μ -RWELL based Muon detector

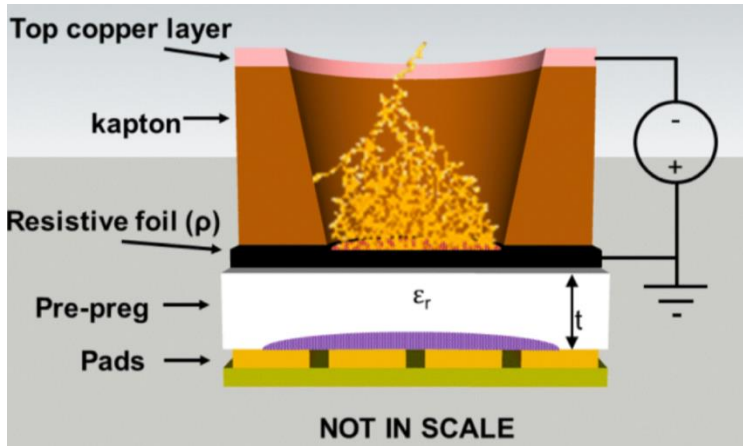
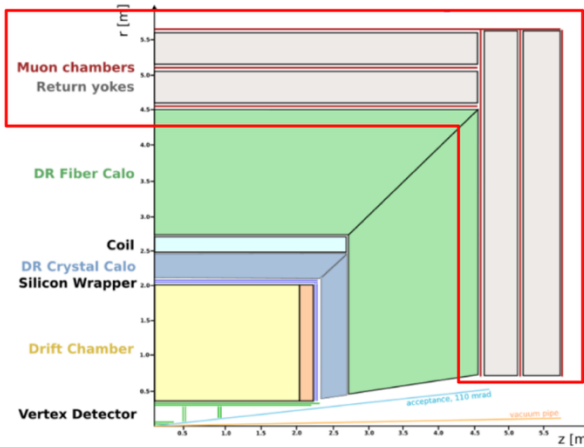
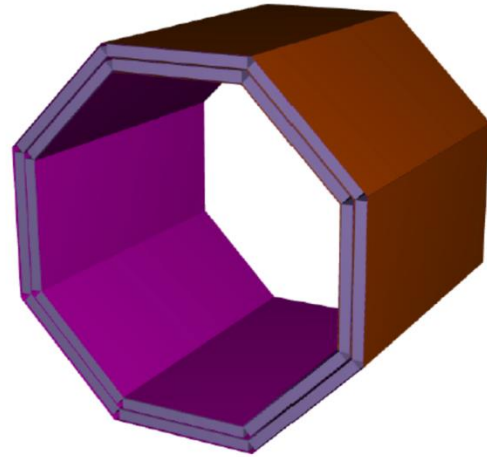
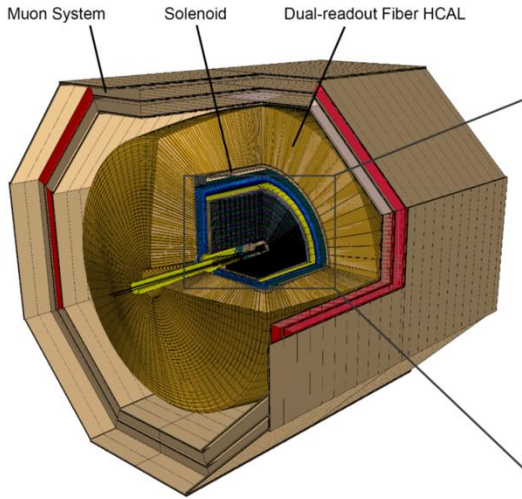

arXiv:2502.21223v1

CLD

RPCs with cells of $30 \times 30 \text{ mm}^2$
(alternatively, crossed scintillator bars could be envisaged)

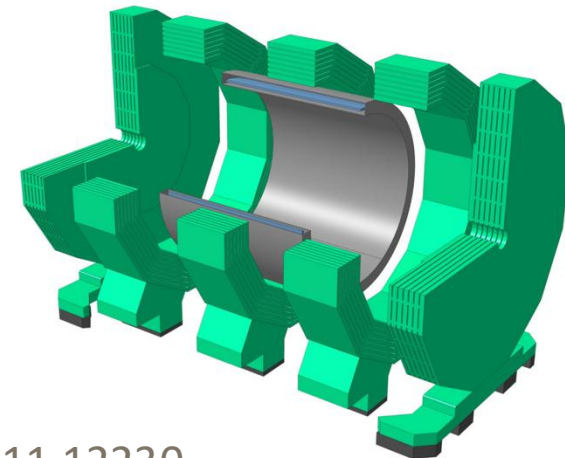
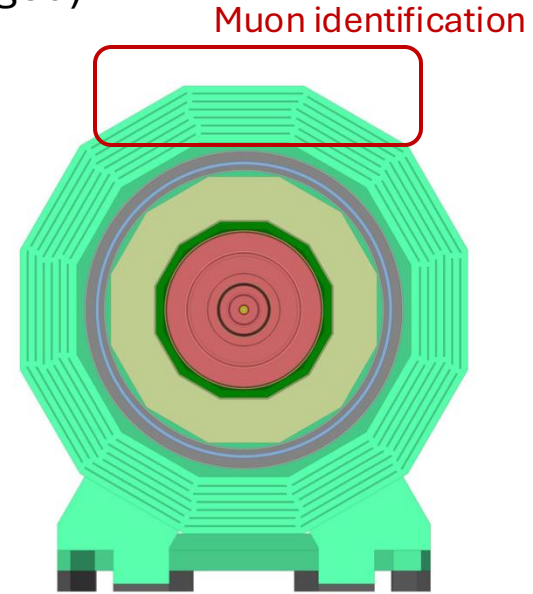
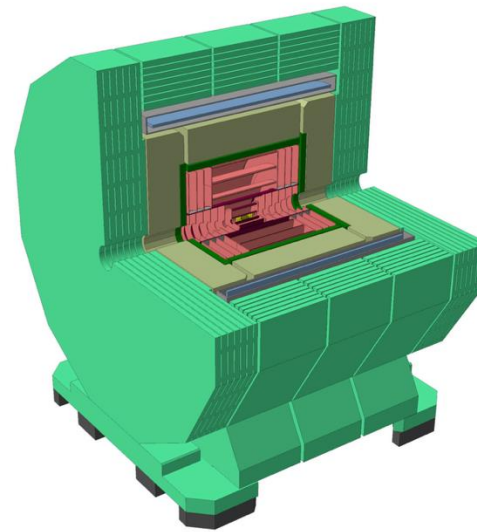

arXiv:1911.12230

FCC-ee Muon System Design Considerations

R&D Proposal for A muon System Made of Drift Tubes and Scintillator Strips For FCC-ee to satisfy the requirements

- **Cost-effective:** Inexpensive to construct and with a low channel count
- **Robust:** Reliable and robust to operate for long term
- **High precision:** Precision position measurements from **drift tubes**
- **Fast:** Fast timing information from **scintillator strips**

Drift tube area

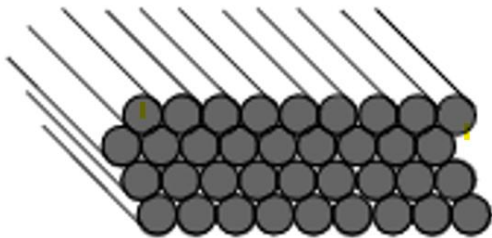

Scintillator strips

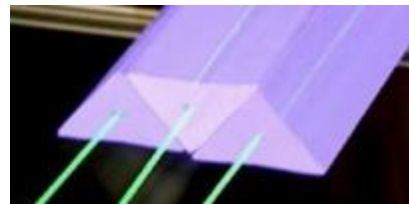

An example of a muon detector module

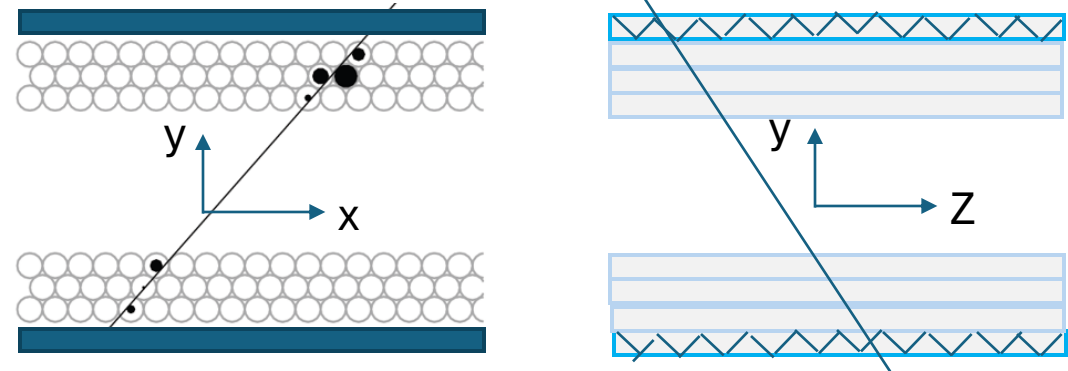

spatial measurements with a hit resolution of $\sigma_{xy} \sim 100 \mu\text{m}$

- Reconstruction of track segments,
- Reconstruction of decay vertices of long-lived particles

with $\sigma_z \sim 1 \text{mm}$ and $\sigma_t \sim 200 \text{ps}$

- Triggers
- Time-of-flight information for massive stable particles, ...

Drift Tube and Scintillator Strip Performance

Excellent performance of ATLAS Precision drift tube muon detector

- ✓ Momentum scale accurate to 0.1%
- ✓ Resolution reached design goal: ~80 μm per tube
- ✓ TDAQ efficiency close to 100%
- ✓ 99.7% fully functional after 15 years operations at the LHC

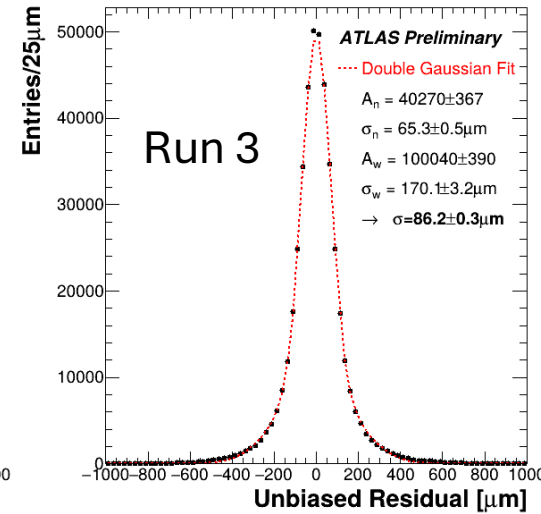
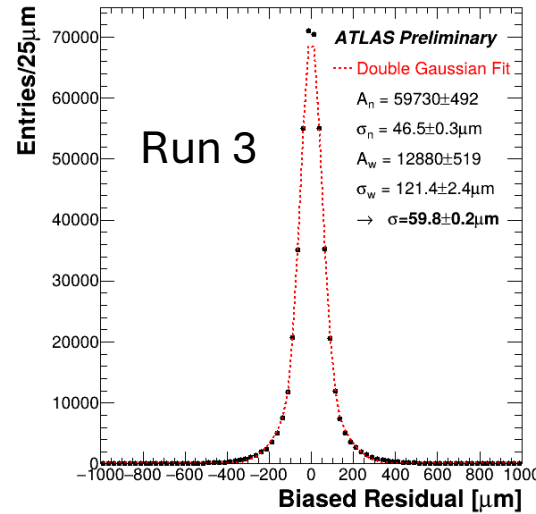

ATLAS muon detector: Big-Wheel

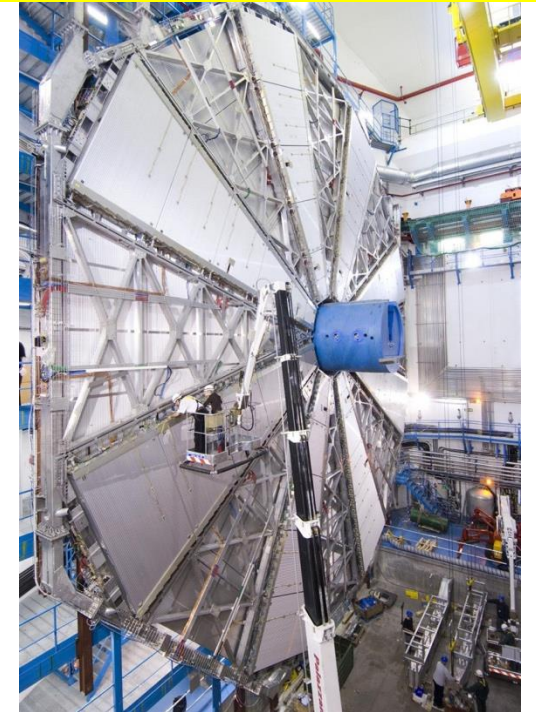

D0 Scintillator strips extruded Scintillator strips at Fermilab, with holes in the middle to house WLS fibers. Visible Light Photon Counters (VLPCs) were used as photodetectors

Now, SiPMs have better specs than the VLPCs and are faster, should improve the performance! Readout both ends for “time-of-flight” information.

Sci. strips for the D0

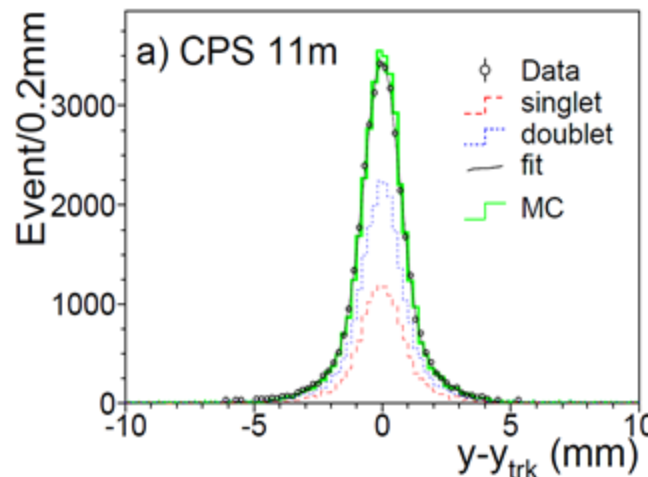

NIM A 378 (1996) 131
arXiv:hep-ex/0007026

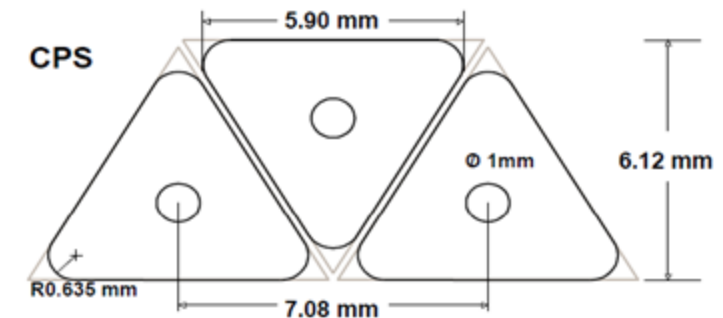

resolution of ~8% of the strip base width

Possible FCC-ee Muon Detector Layout & Channel Counts

Possible barrel chamber layout

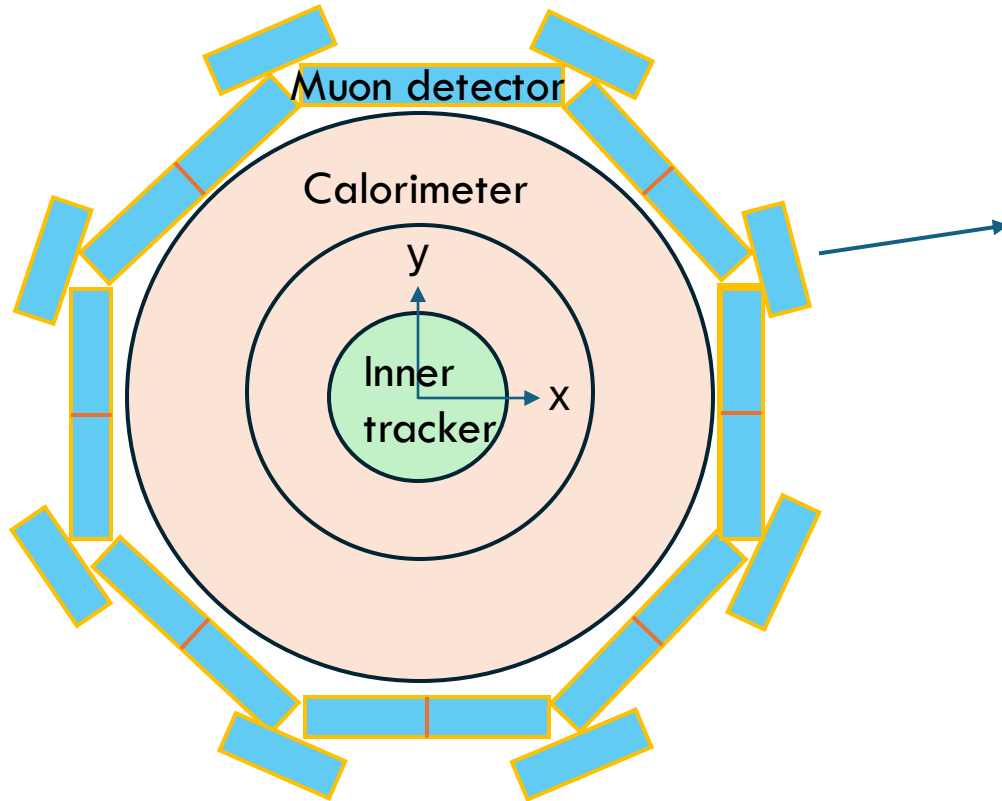

Solenoid central magnet

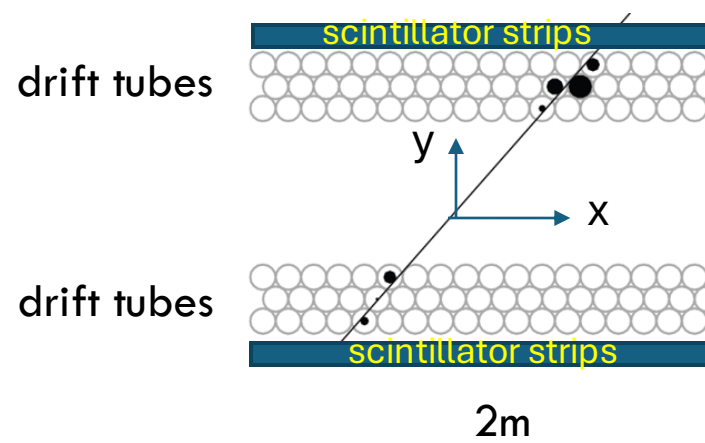

a muon detector module

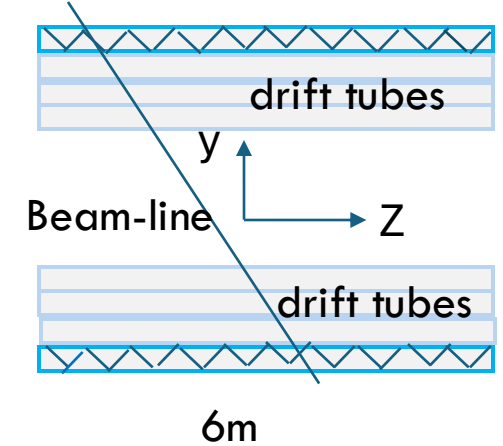

Possible end-cap chamber layout

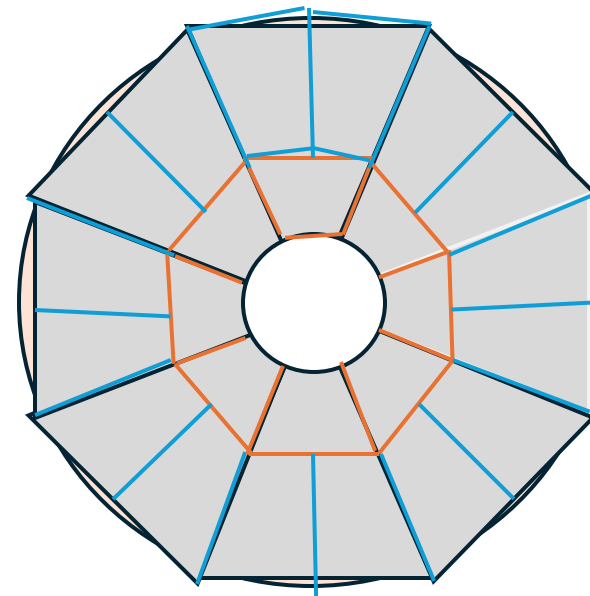

Each sector: 3 chambers:
 Small chamber $R = 1.0 - 2.5$ m
 Large chamber $R = 2.5 - 4.5$ m

Total tubes : **17,856**
 Total scintillator strips: **6000**

Barrel + endcaps
 Tubes: **36,288**
 Strips: **25200**
 Total channels: **61,488**

Each module of muon chamber size: **2m x 6m**
 Number of chambers in barrel: $(8 \times 3) \times 2 = 48$
 Drift tube diameter: 3 cm, 384 tubes/chamber
 Total number of drift tubes: $(384 \times 3 \times 8 \times 2) = 18432$
 Total number of scintillator strips: **9600x2** (6m+2m)

R&D – Muon System Optimization

- Use extrusion drift tubes (example: 1-inch **squared tubes**), cost will **reduce a factor of 5** on tubes, and the construction process will be simpler. The performance study is important.
- Chained readout of scintillator strips to reduce the number of readout channels by **a factor of 2**
- Optimization of single detector size
- Detector design, construction procedure, and readout electronics and DAQ system
- Eco-friendly gas mixture and possible circulation system studies

R&D: Squared Drift Tube Chamber Prototype

<https://indico.fnal.gov/event/67484/sessions/26357/#20250416>

University of Michigan

A muon detector module:
squared drift tubes + triangle scintillator strips

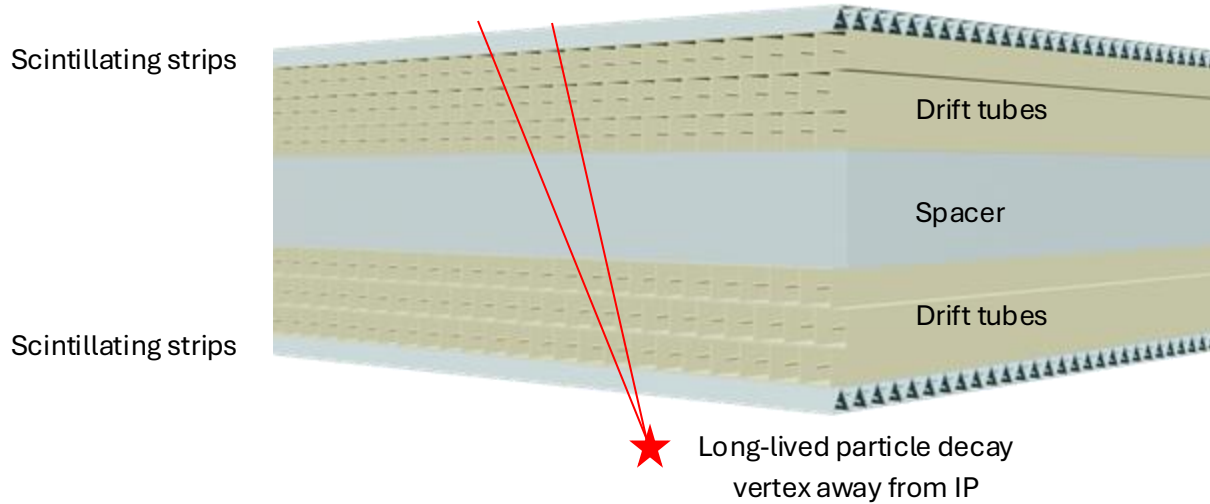

Prototype design

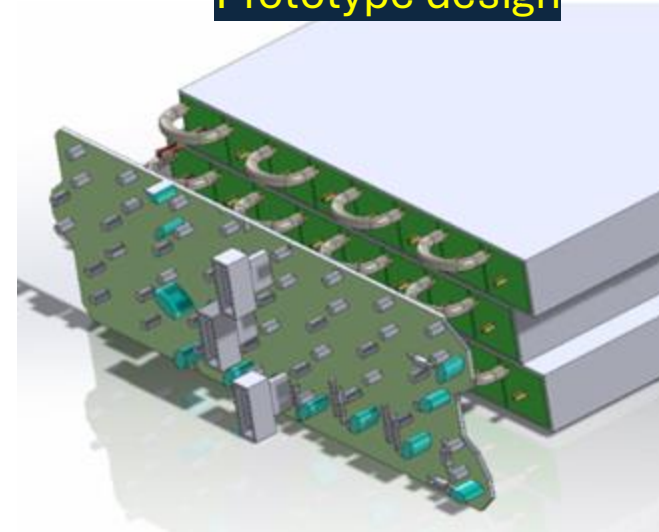

Wire connection with MDT HH

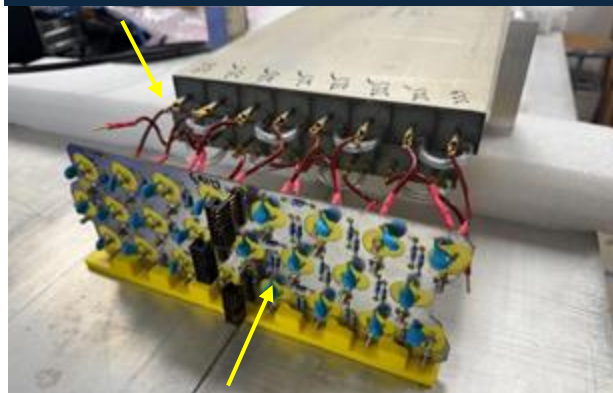

MDT readout hedgehog board

Faraday cage

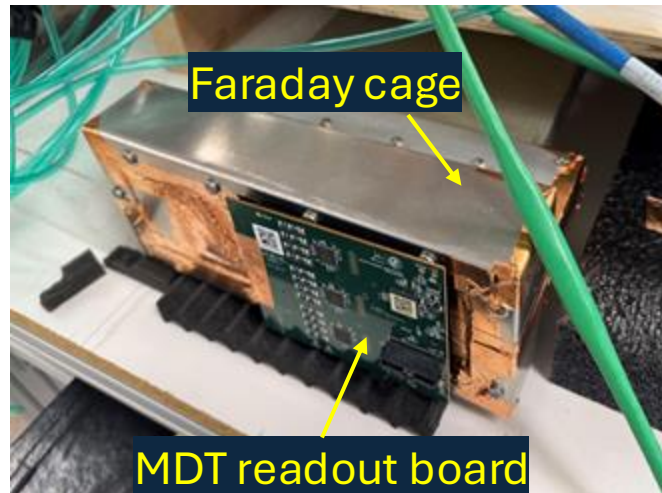

MDT readout board

Faraday cage (HV side)

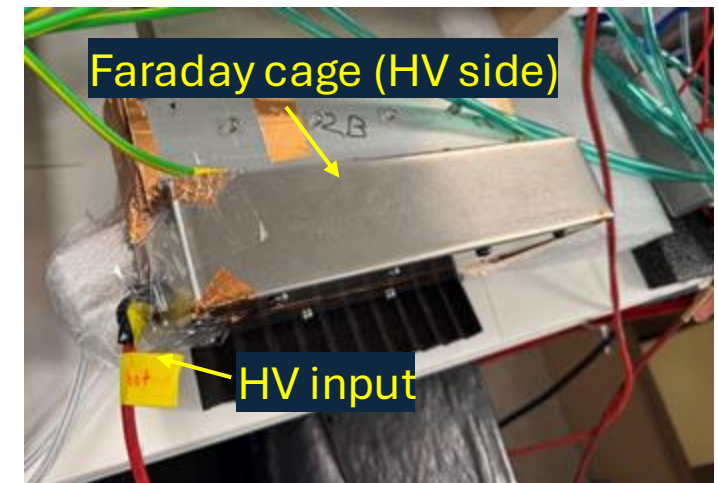

HV input

R&D: build and test squared tube prototype

University of Michigan

Garfield simulation of the square tube electric properties

1 inch square-tube simulation Ar:CO₂ 93:7, 1 atm, 1650 V

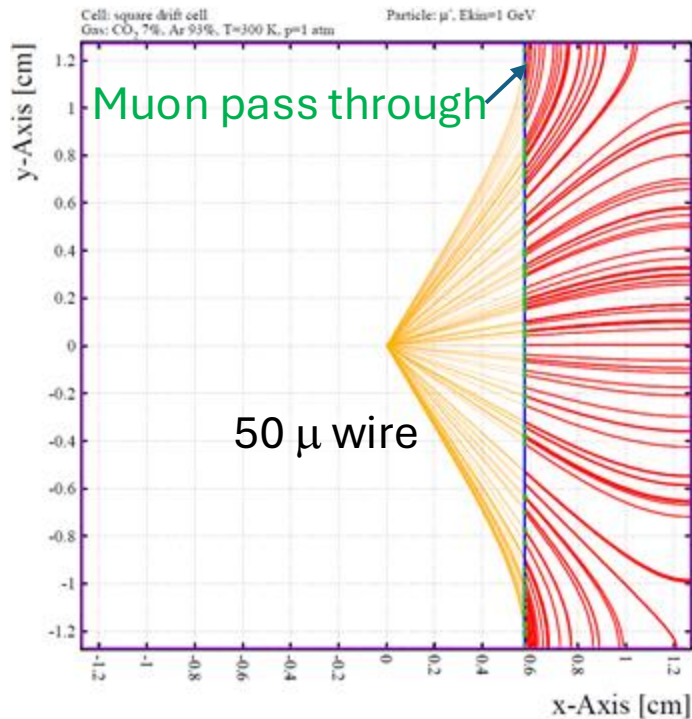
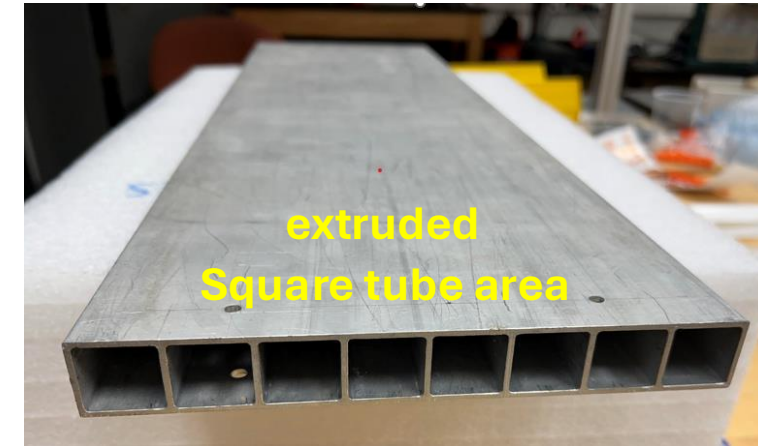

Ionized electrons along the muon track drift to wire

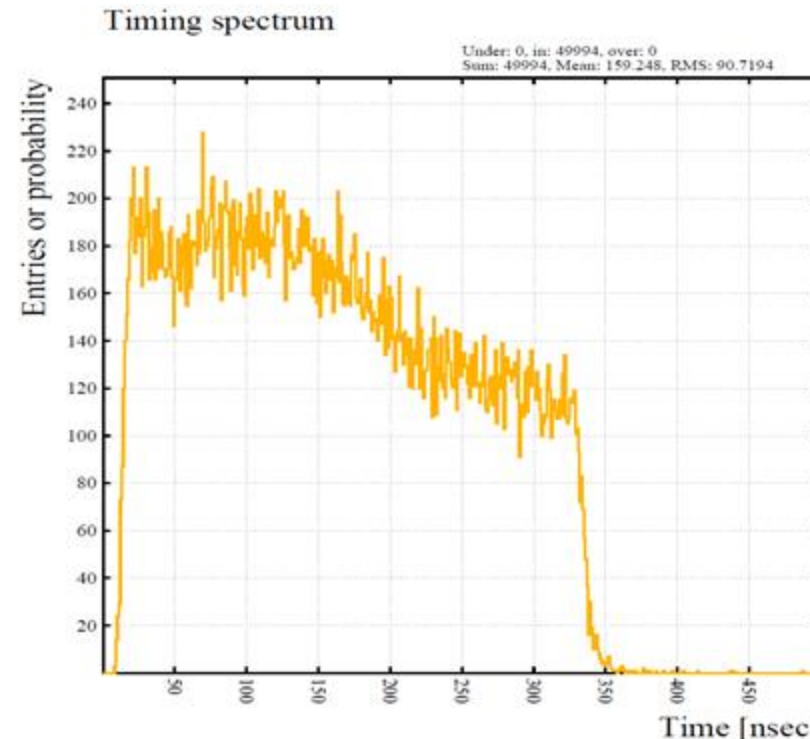

Drift time spectrum

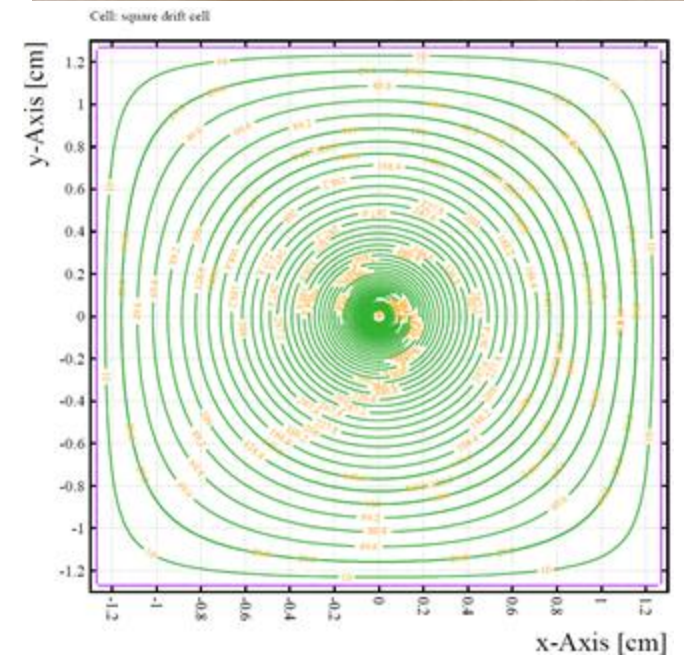

E-field potential contour

Cosmic Ray Test Station at University of Michigan

3D sMDT
reference
tracker with
spatial
resolution
of $\sim 100 \mu\text{m}$
per tube

Squared tube
prototype

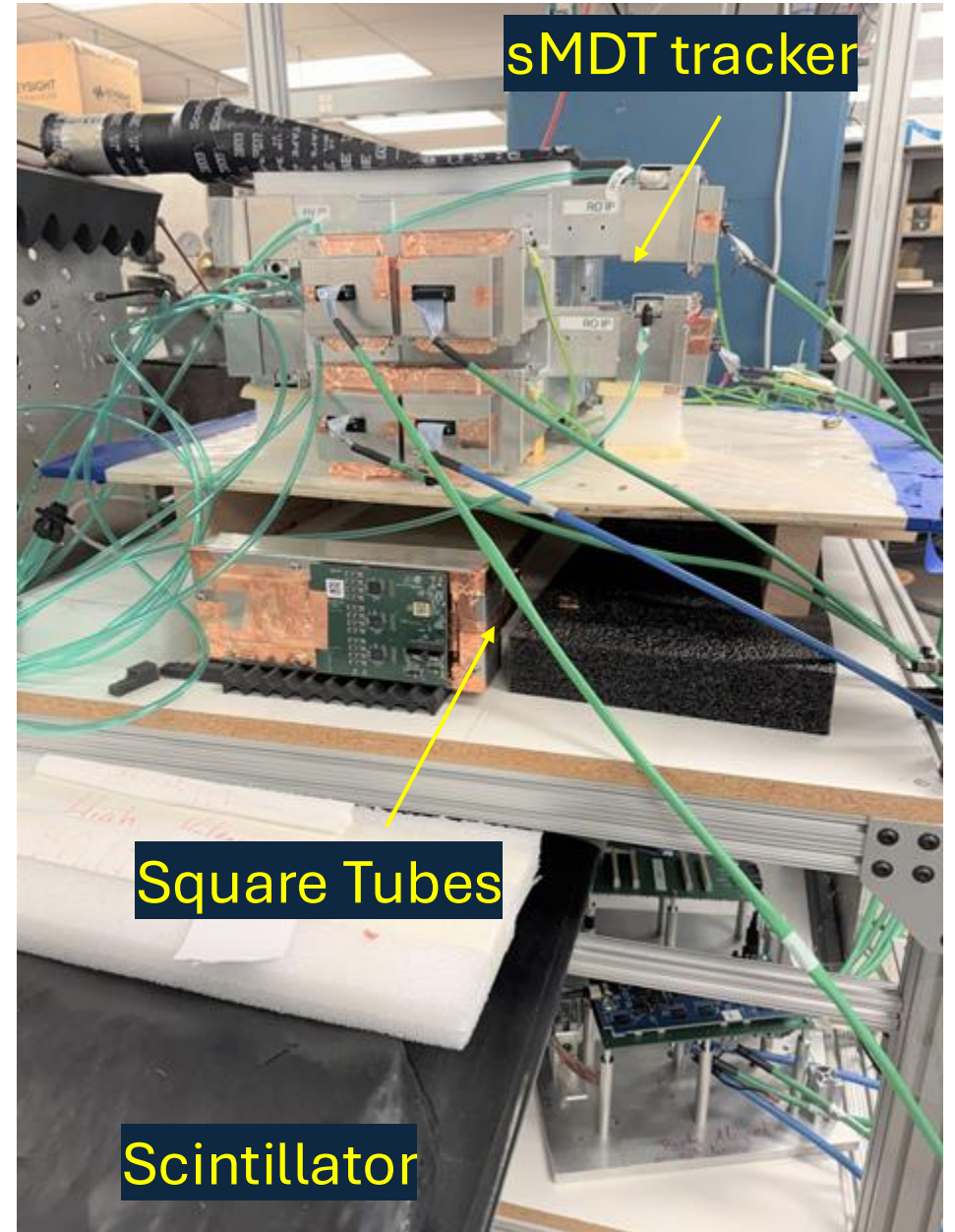
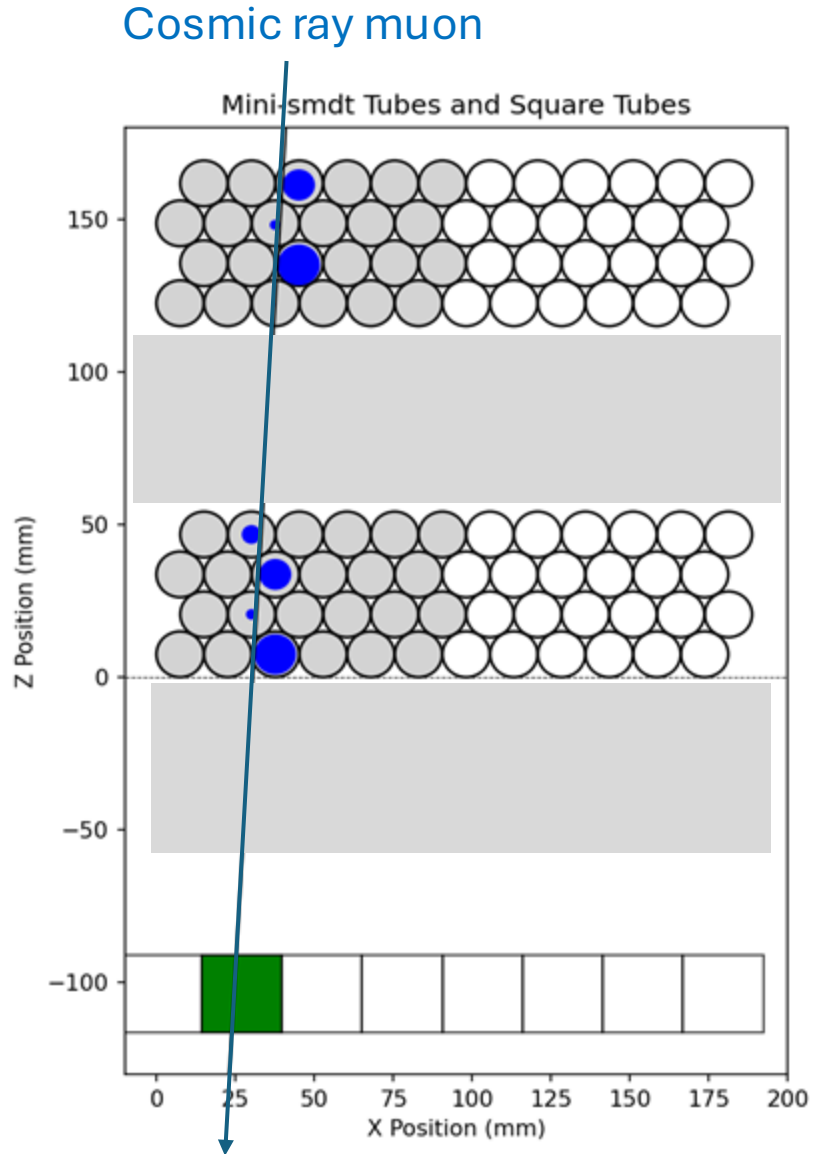

Square-tube ADC and Drift time (TDC) spectra

Square tube ADC
Ar:CO₂ 93:7,
1.65 bar, 2176 V

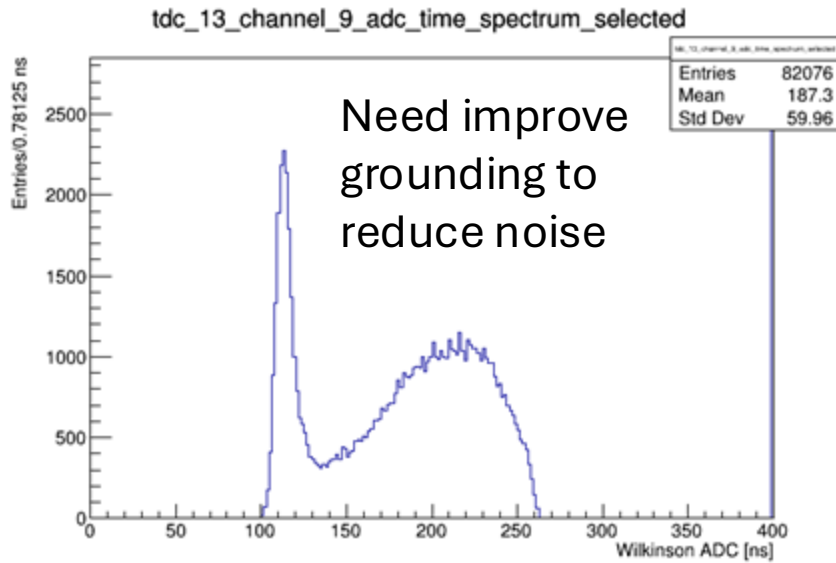

tdc_4_channel_20_adc_time_spectrum_selected

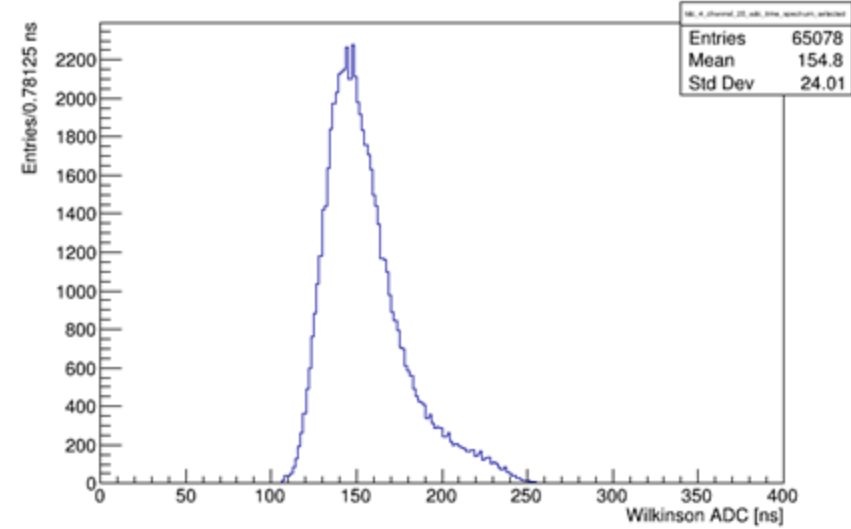

sMDT ADC
Ar:CO₂ 93:7,
3 bar, 2730 V

Require detailed calibration

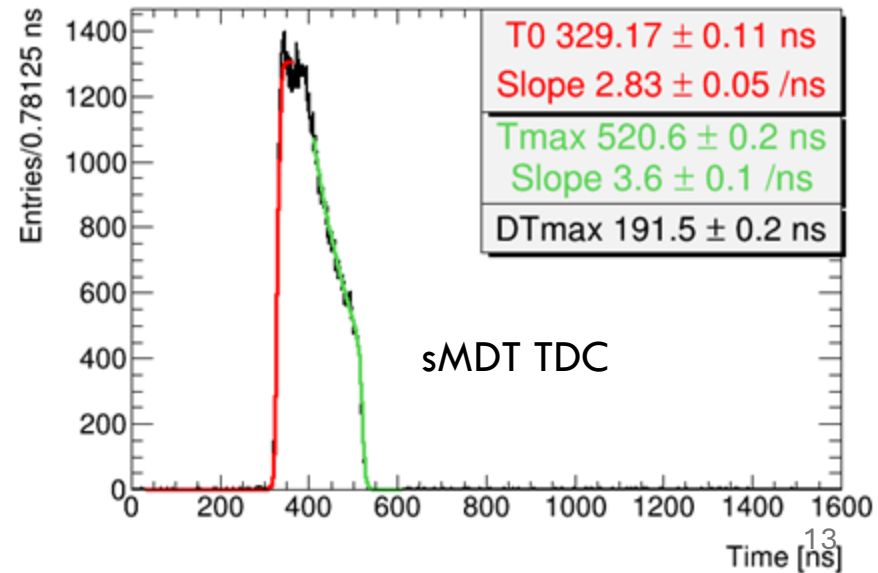
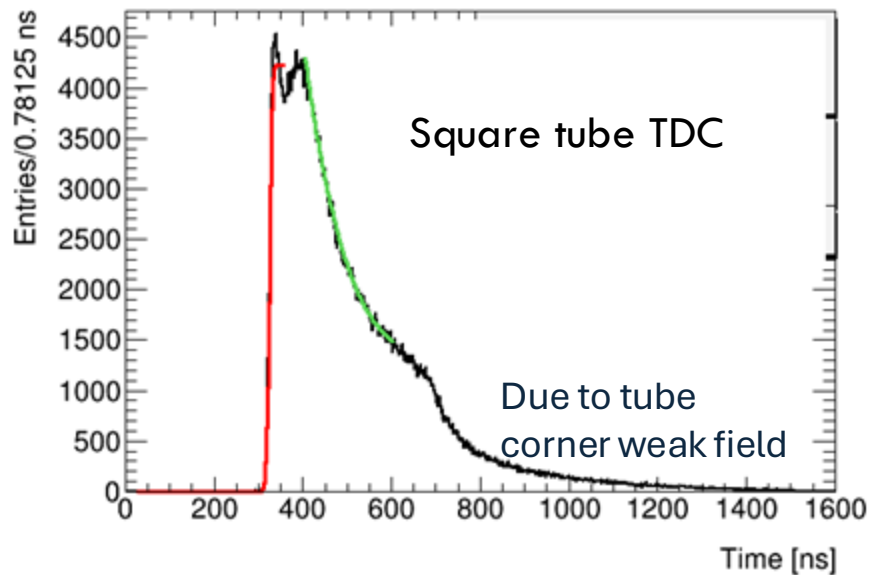

Study of Drift Gas Mixture

- Search for new environmentally friendly gas mixtures is necessary to reduce greenhouse gas emissions and costs as well as to optimize detector's performance
- Study the Ar:CO₂ mixture component ratio to maximize the detection precision
- Build and test/calibrate a gas mixture system. Study the gas gain with a small straw chamber using ⁵⁵Fe. SMDT chambers are used to study the tracking performance

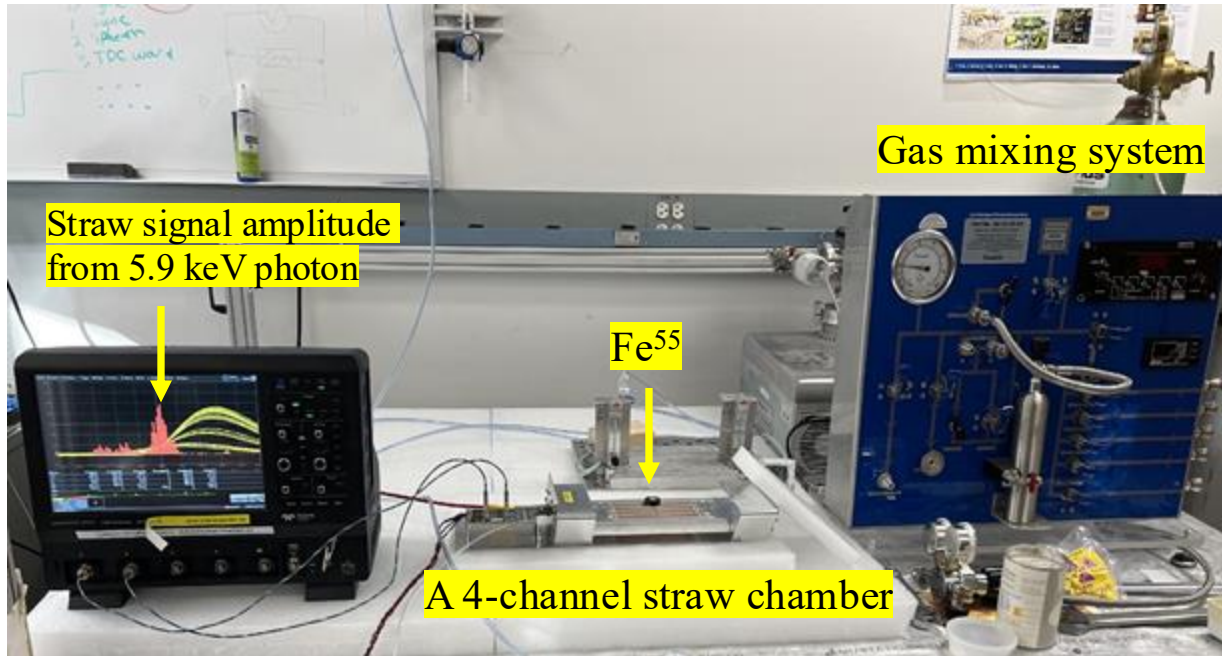

$$\begin{aligned}
 \text{gain} &= \frac{\text{output charge}}{\text{input charge}} \\
 &= \frac{(\text{mean pulse height}/2\text{mV}) \text{ fC} \times 10^{15}}{\text{No. of primary electrons} \times e C}
 \end{aligned}$$

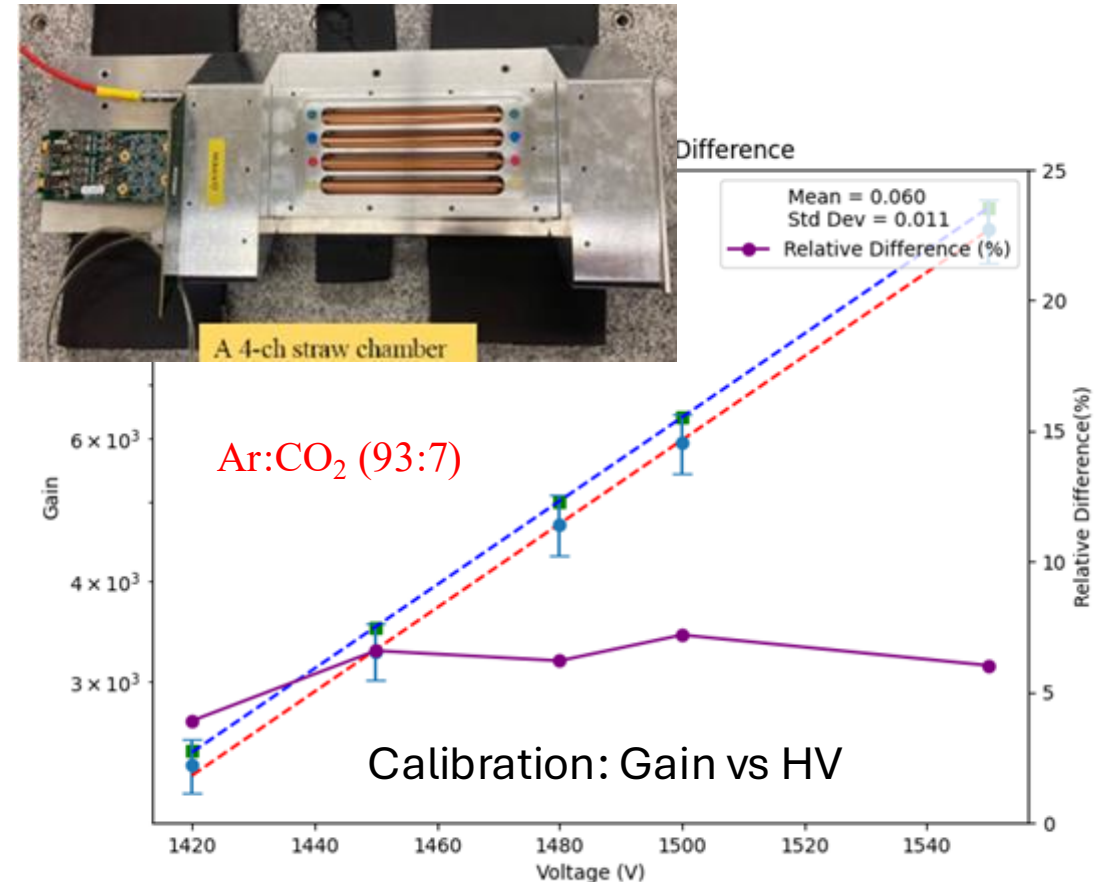

Compare between gas mixture and pre-mixed gas

Study Gas Mixture with Cosmic Ray Test

Drift time and Tracking Resolution Comparison

Using ATLAS sMDT muon chambers to study the drift time and resolution at pressure = 3 bar, drift gas from the gas mixture system, Ar:CO₂ mixtures of 93:7 (standard ATLAS muon gas), 80:20, and 70:30 with cosmic ray tests for maximum drift time and tracking resolution (per tube) comparison:

- More CO₂ component, longer drift times, and better tracking resolution (improvement by 15% and 22% for CO₂ fraction of 20% and 30% in the gas mixture compared to the standard ATLAS gas)

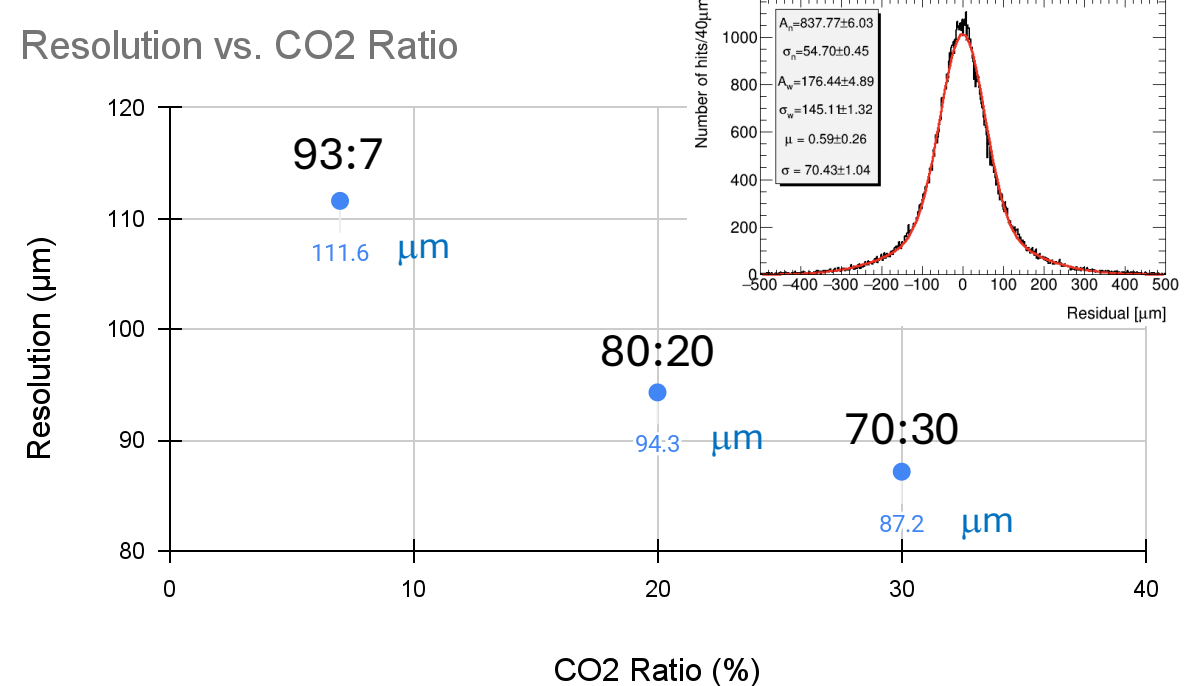
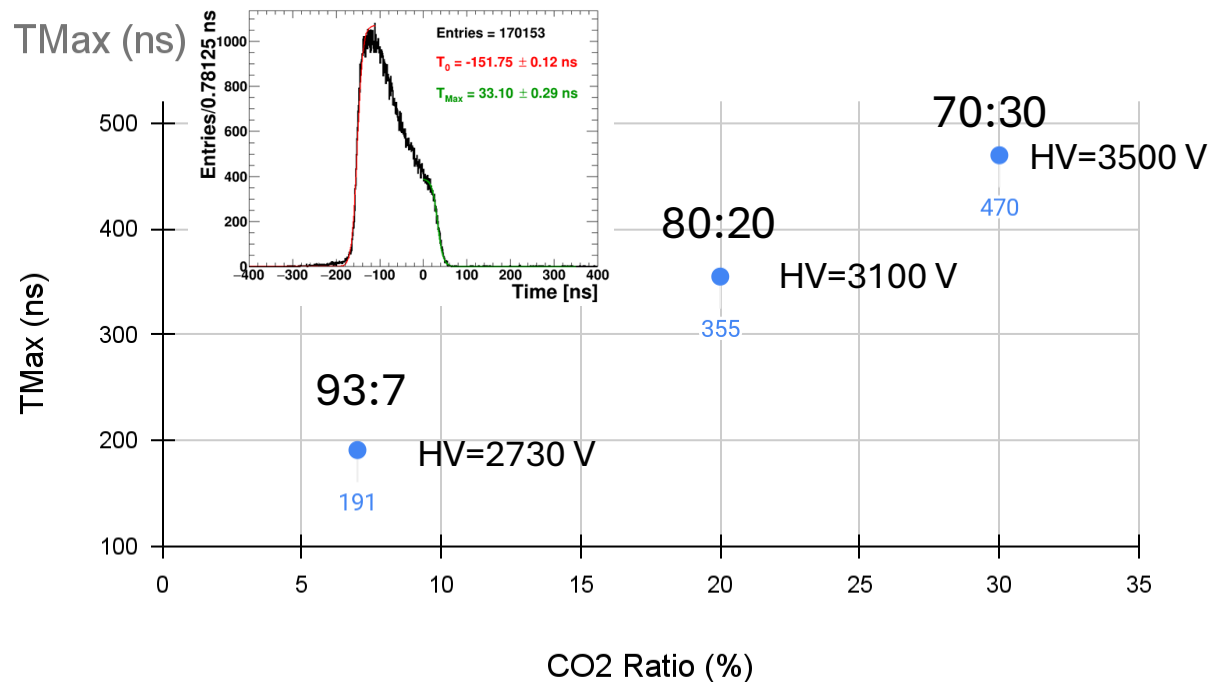

Scintillator

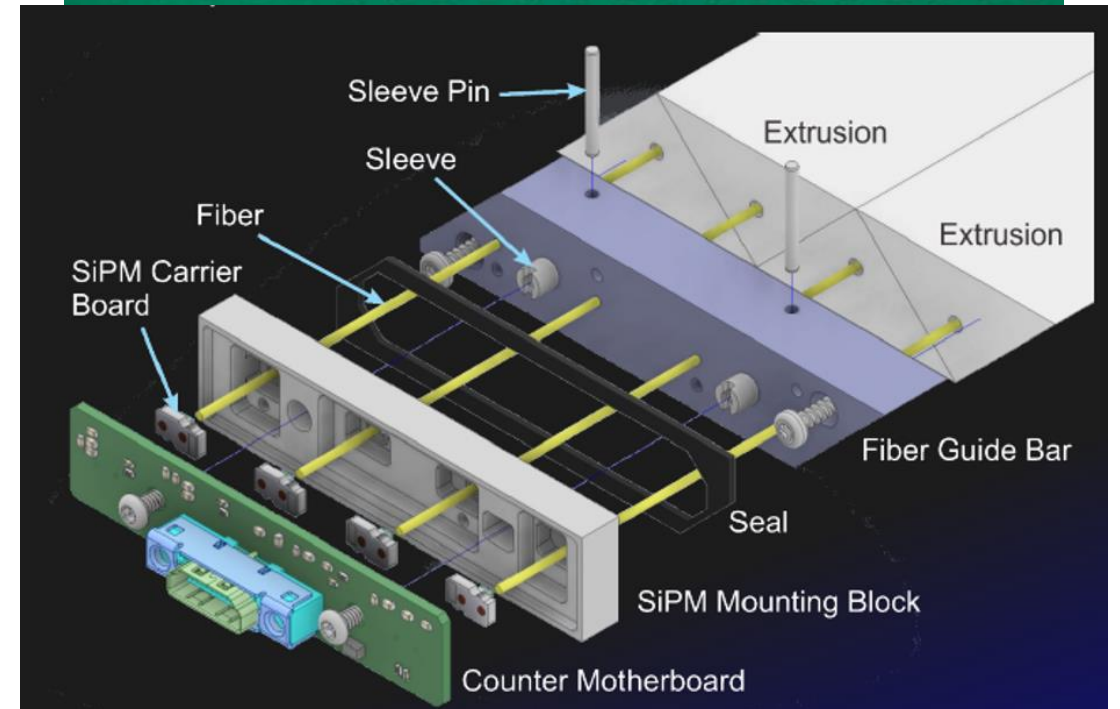
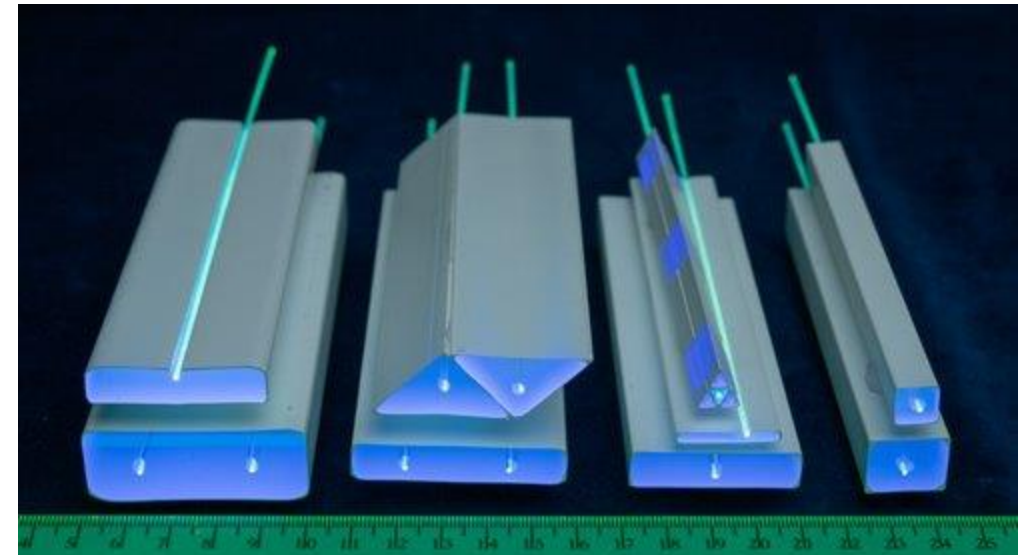
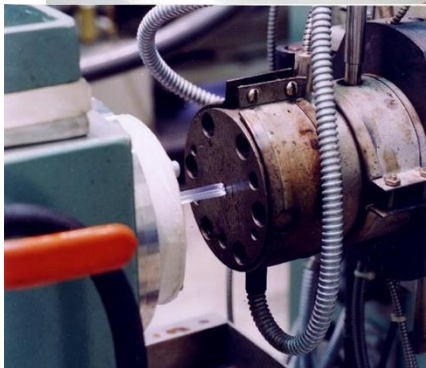
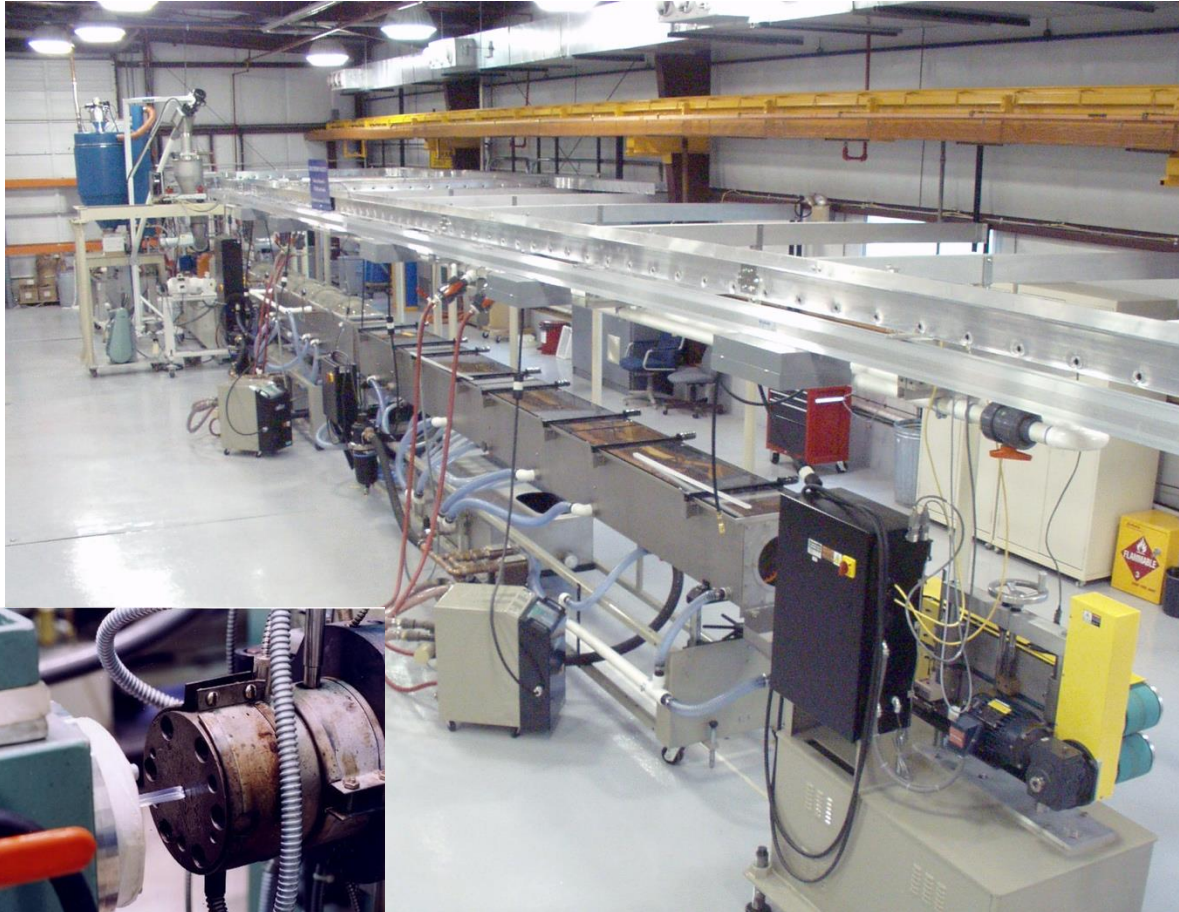

Strip Construction in Michigan's Lab

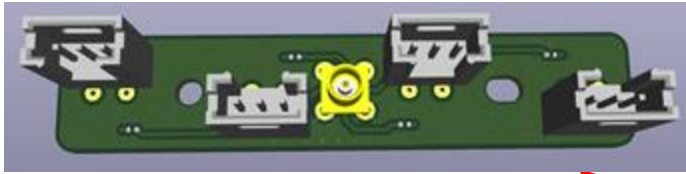

Front-End Board (producing now)



SiPM holder

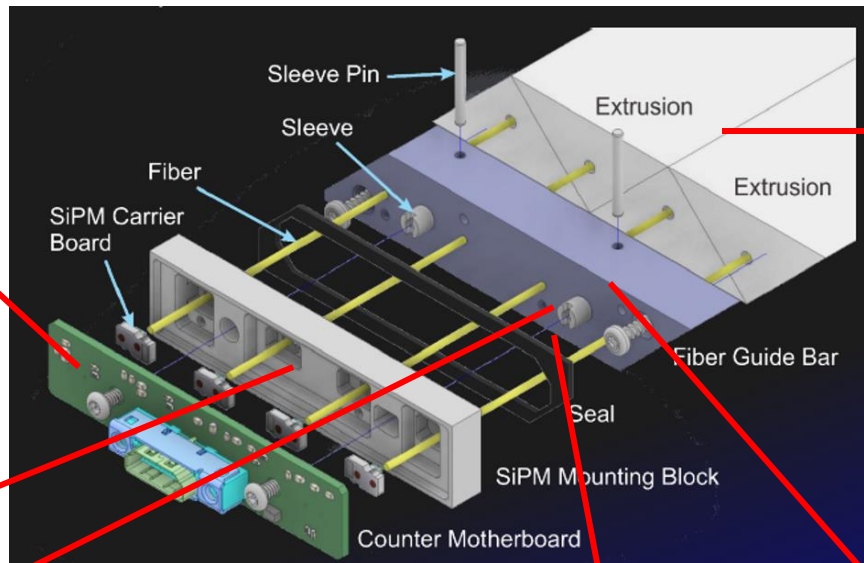

Group the strips

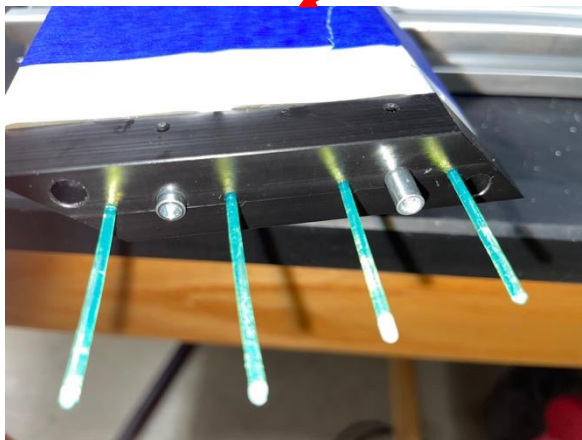
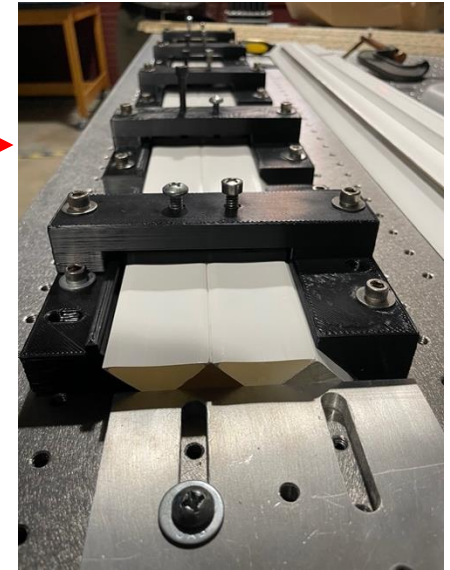

Connect strip, fibers and fiber guider



Polish and flat the surface



Drill holes on the fiber guider

DAQ module from CAEN

- CAEN DT5202, a 64-channel module for SiPM bias voltage and signal readout
- Each readout channel is composed of a Preamplifier, a Slow Shaper with peak sensing detector, and a Fast Shaper followed by a discriminator
- Dynamic range: 160 fC to 400 pC (i.e. from 1 to 2500 photo-electrons with 10^6 SiPM gain)
- Dual range: low gain = 60 v/v and high gain = 600 v/v for peak finding, max. trigger rate ~ 100 kHz
- 0.5 ns LSB for time of arrival (TOA) and time over threshold (TOT)

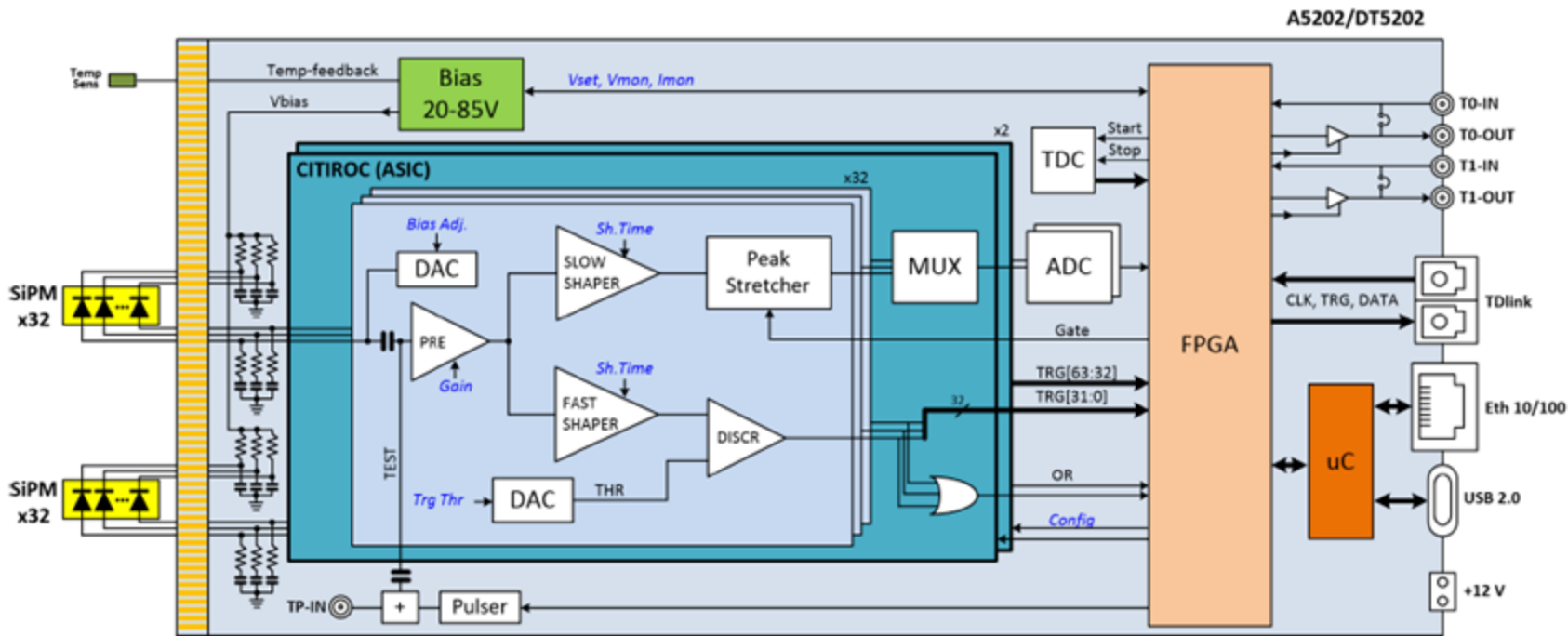

block diagram of the DT5202 unit



DT5202 unit

DAQ module from CAEN

- CAEN provided configuration GUI and online histogram monitoring (up to 8 channels plotted at a time)
- DAQ can record shaped pulse height, TOA and TOT at the same time

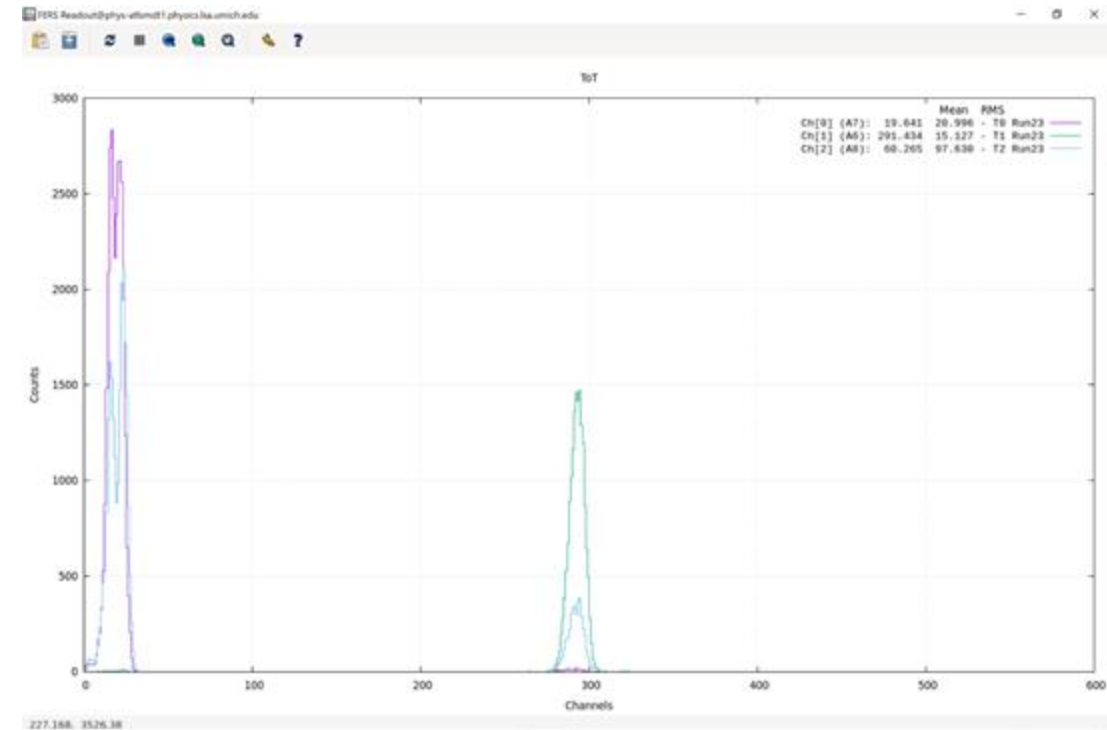
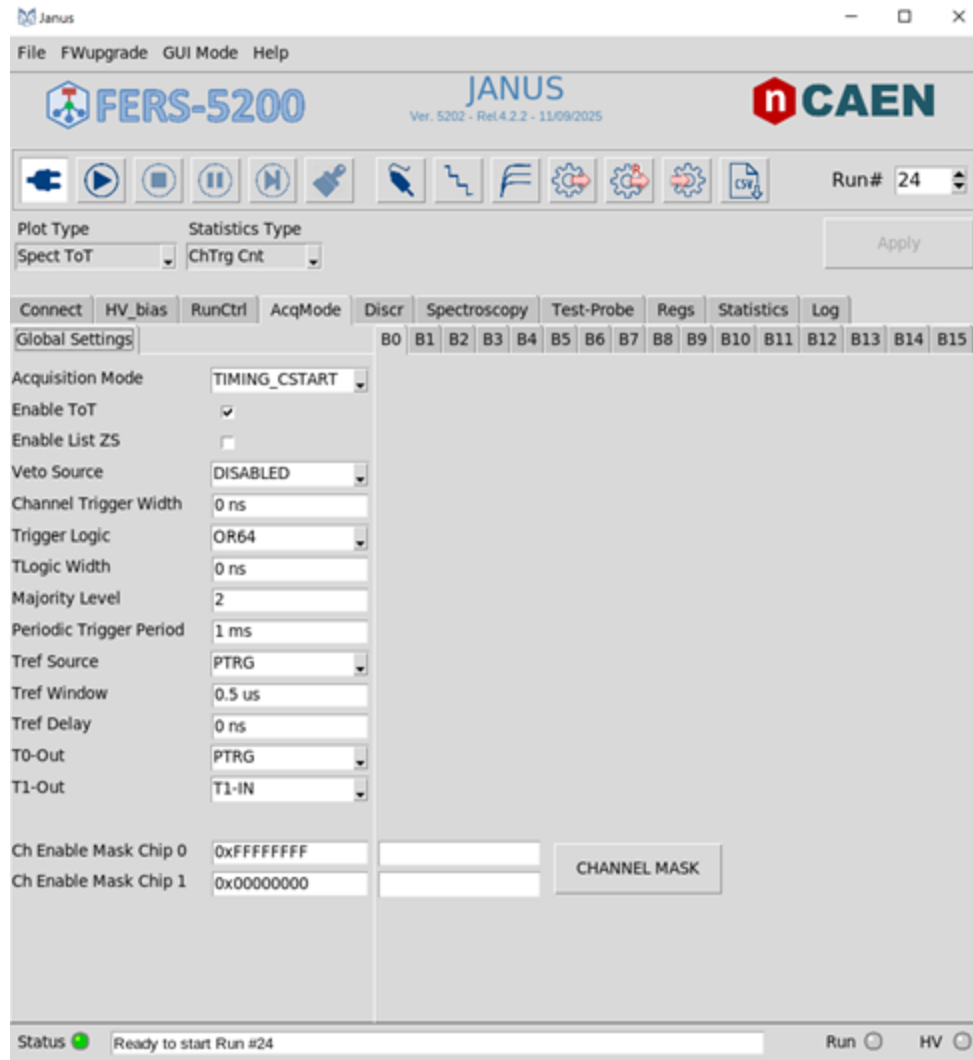

Summary

- A combination of drift tubes and scintillators for a muon system is a **high precision, fast timing, robust, and cost-effective** option to meet the muon detection requirements at FCC-ee
- Use a simplified detector layout (based on the ATLAS 3 cm diameter MDTs and the 2 cm triangle scintillation strips geometry) to estimate the total channel counting: $\sim 61.5k$
- **On going R&D:**
 - ❖ Square drift tube prototype, much cheaper than ATLAS round tubes, is built and used ATLAS MDT electronics for readout
 - Develop method to reduce the noise of the squared tube chamber
 - Develop techniques for calibration of the squared tube chamber to improve the resolution
 - ❖ Initial scintillator strip tests at Fermilab and Rome
 - Demonstrate spatial resolution: $\sigma = 2$ mm
 - Measured timing resolution: $\sigma = 380$ ps
 - ❖ Gas mixture system has been built and calibrated
 - Compared pre-mixed gas and the gas using the mixture system for gain measurement
 - Compared drift properties of different Ar:CO₂ mixtures
 - ❖ Plan - test beams and set up simulation programs
 - Scheduled test beam at CERN this year
 - Develop software based on Geant 4 simulation for overall performance of the muon system

Additional slides

R&D Proposal for A muon System Made of Drift Tubes and Scintillator Strips For FCC-ee

A combination of drift tubes and scintillators for a muon system is a **high precision, fast timing, Robust, and cost-effective** option to meet the muon detection requirements at FCC-ee. A modest support holds high strategic value of the R&D program.

Drift tube and Scintillator layout

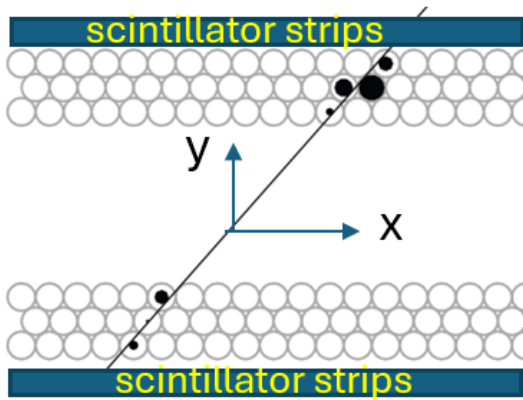

sMDT spatial resolution (2024 TB)

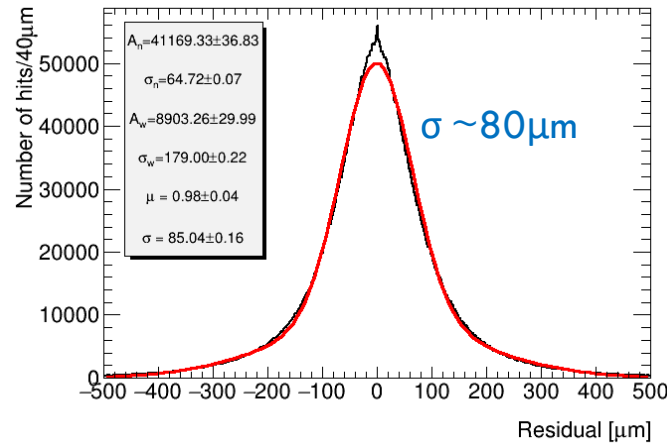

Scintillator strips module with SiPM

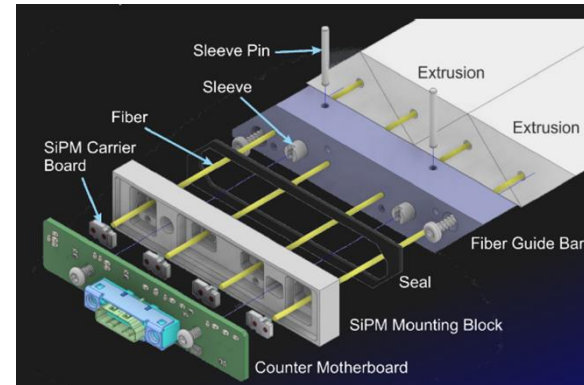

Scintillator Strip Test (Rome)

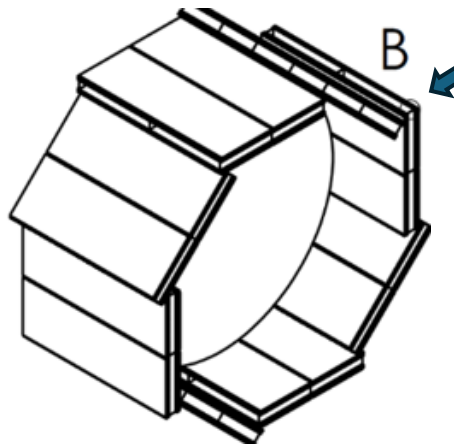
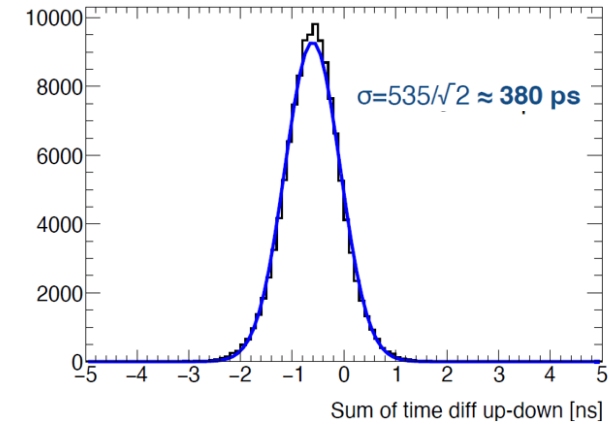

A drift tube + scintillator strip module (2m x 6m)

Build a 2-ML module (tube+strip) and the associated front-end readout electronics, with the goal of demonstrating both spatial and timing resolution performance with test beam experiment.

Layout for Geant4 simulation

ATLAS MDT chamber

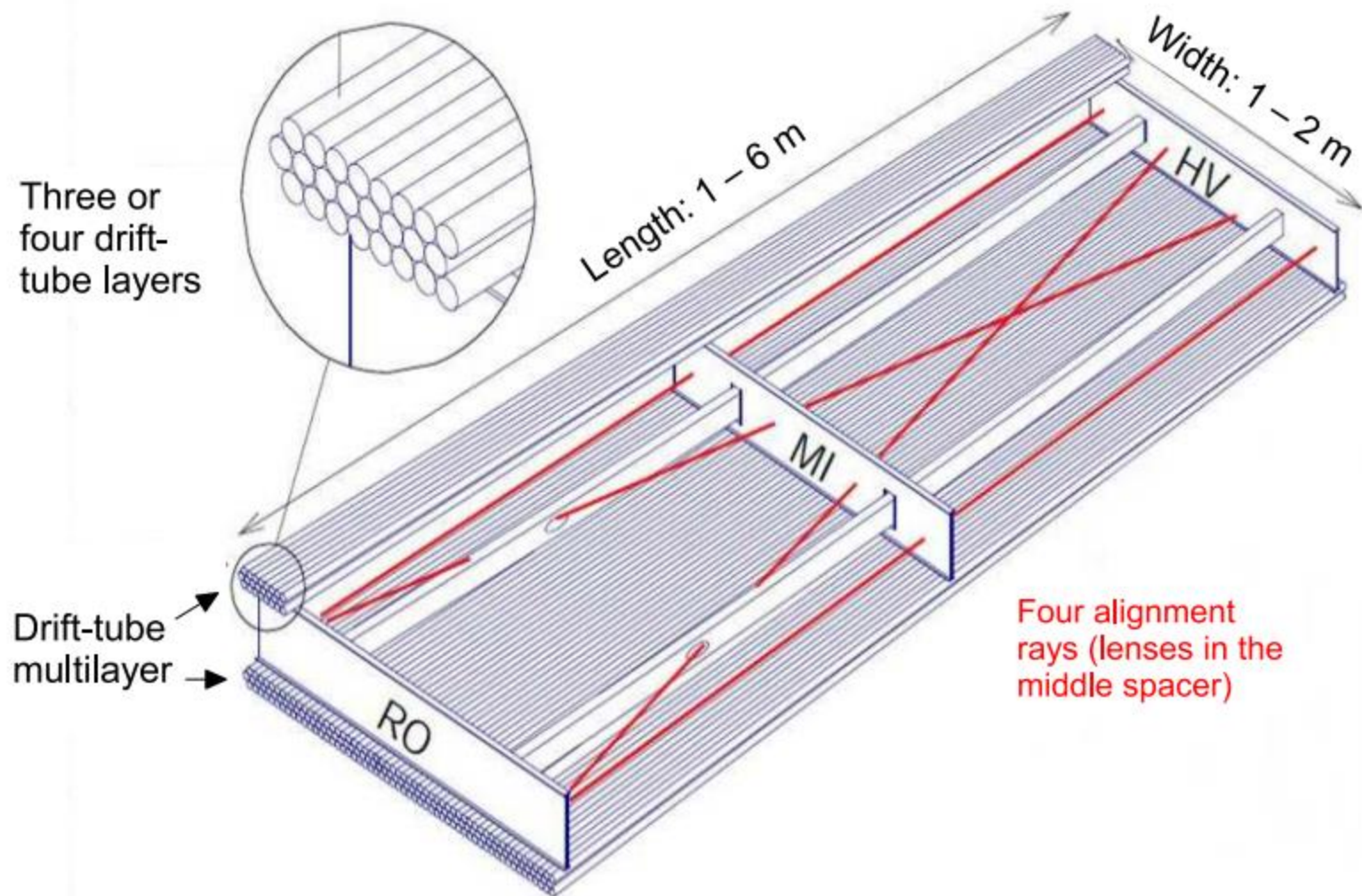

A Concept: Drift Tube and Scintillator Muon System

A combination of drift tubes and scintillators is a cost-effective option to meet the requirements of a muon detector at FCC-ee:

- Drift tubes and scintillator strips can be produced cost-effectively through extrusion
- Drift tubes provide good spatial resolutions
- Scintillators with SiPM readouts offer excellent timing information
- They have low channel counts and are robust!

Multiple layers of drift tubes for bending-plane spatial measurements with a hit resolution of $\sigma_{xy} \sim 100\mu\text{m}$

- Reconstruction of track segments,
- Reconstruction of decay vertices of long-lived particles

Triangular scintillator strip layers sandwiching the drift tubes for the z-coordinate and timing measurements with $\sigma_z \sim 1\text{mm}$ and $\sigma_t \sim 200\text{ps}$

- Triggers
- Time-of-flight information for massive stable particles, ...

This configuration design can be easily extended to 2-3 such layouts for independent momentum measurements (as ATLAS and CMS muon system)

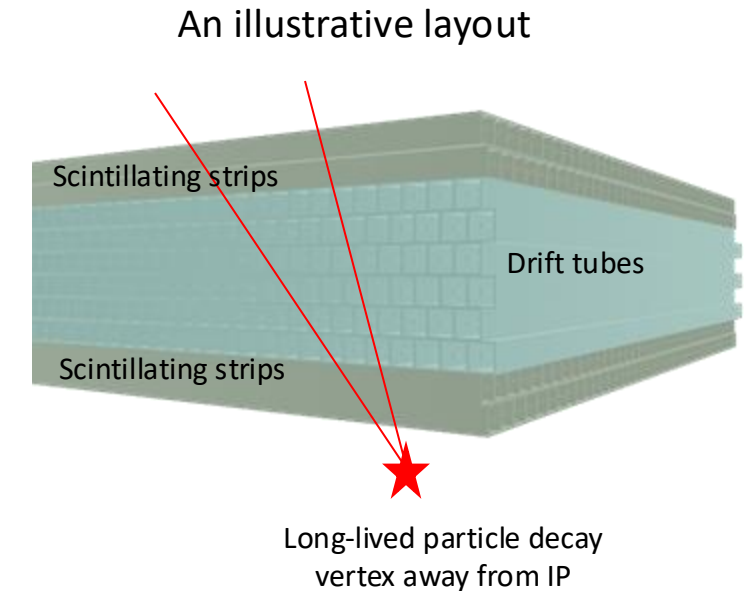

Possible Barrel Muon Detector Layout & Channel Counts

Solenoid central magnet

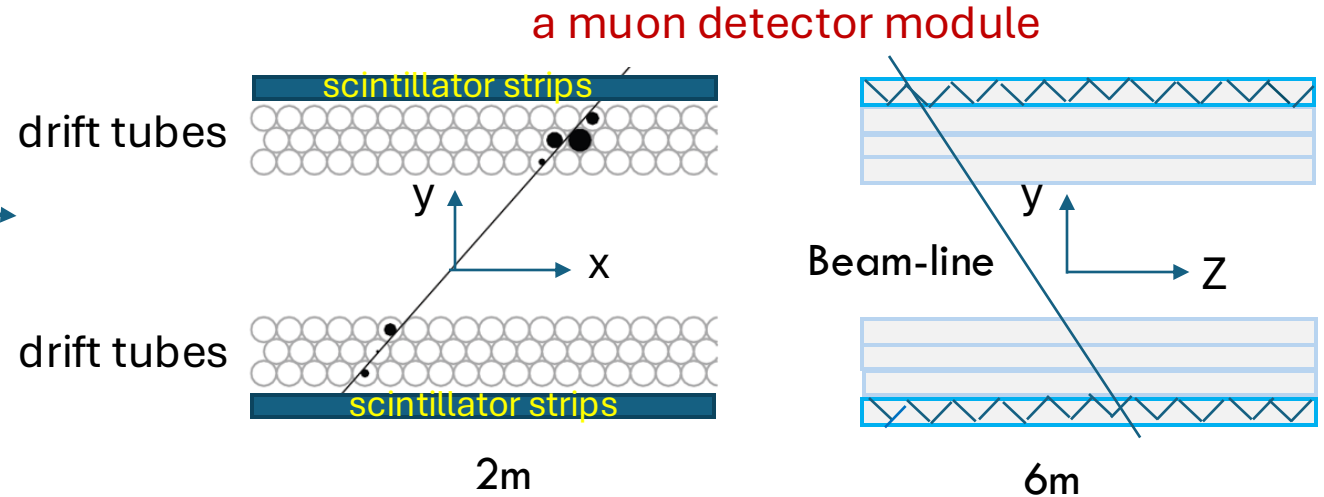
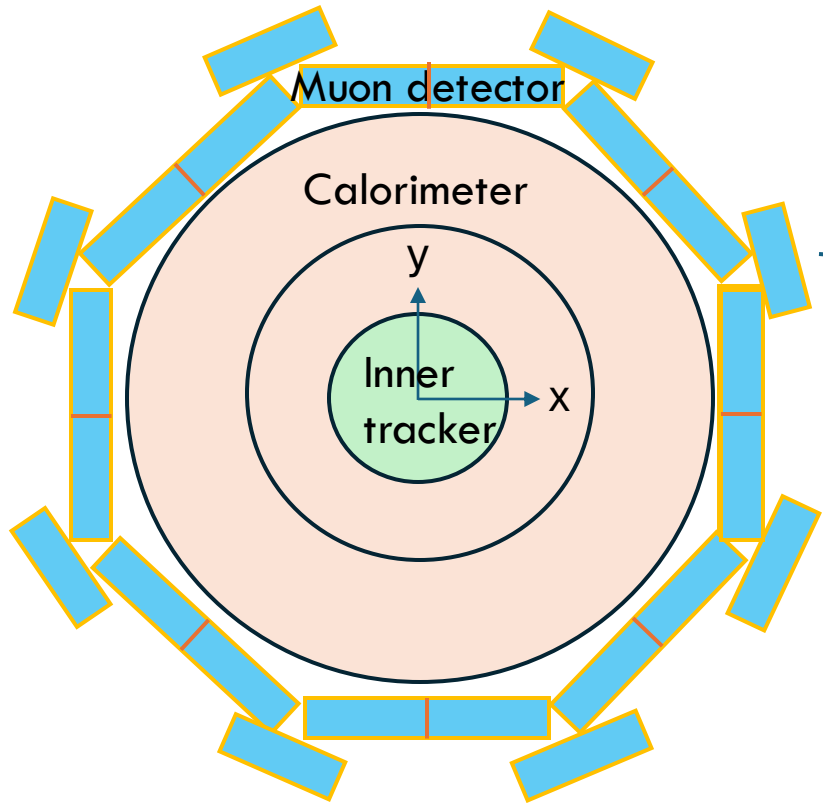

Using ATLAS BOL chamber as an example:

Each module of muon chamber size: 2m x 6m

Number of chambers in barrel: $(8 \times 3) \times 2 = 48$

Ref: Num. of ATLAS BOL chambers: 96

Each module consists of

384 drift tubes of diameter=1.5cm, 64 tubes/layer

Arranged in two multi-layers with a spacer of 35 cm

Total number of drift tubes: $(384 \times 3 \times 8 \times 2) = 18432$

Number of scintillator strips:

$(300 \times 2) \times 2 = 1200$ 4m-long scintillator strips / wider chamber

Total $1200 \times 8 = 9600$ 4m-long strips + 9600 2m-long strips

Endcap muon system layout and channel counts

- The end-cap chamber design will depend on the magnet configuration
- Assume solenoid central magnet, the end-cap field lines have larger components perpendicular to the beam line

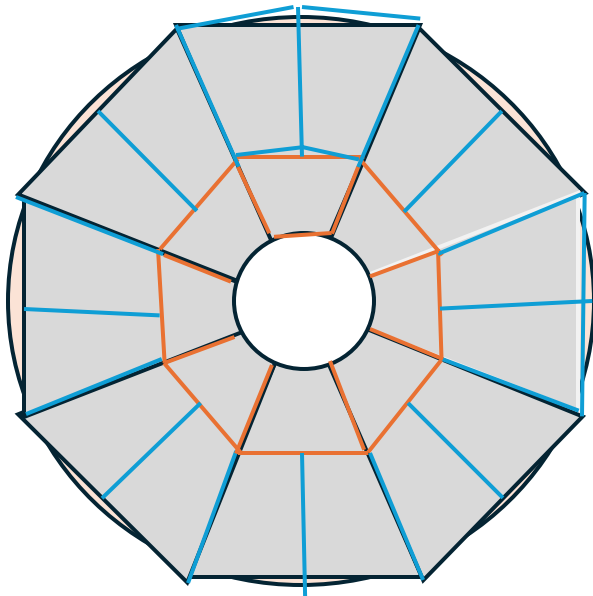

Schech of the endcap big-wheel of the muon system

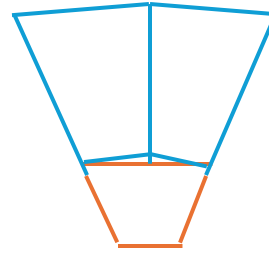

Each sector consisting of 3 chambers:
Lower chamber: $R = 1.0 - 2.5$ m
Top chambers (2): $R = 2.5 - 4.5$ m

Drift tube wire perpendicular to the beam line
Scintillator strips perpendicular to tubes, and beam line

Three tube layers: 408 tubes/small-chamber
708 tubes/large-chambers
Total number of tubes for 2 end-caps: **17,856**
Total number of scintillator strips for 2 end-caps: **6000**

Total number of drift tubes (3 cm in diameter) for barrel + endcaps of the muon system: **36,288**

Total number of scintillation strips (2 cm base): **25,200**

Total readout channels for the proposed muon system: 61,488

Study of a gas mixture system

- Use ^{55}Fe for gain study
- Calculate the gain with

$$\begin{aligned} \text{gain} &= \frac{\text{output charge}}{\text{input charge}} \\ &= \frac{(\text{mean pulse height}/2\text{mV}) fC \times 10^{15}}{\text{No. of primary electrons} \times e C} \end{aligned}$$

- An error of about 5% in the comparison between premixed gas and gas mixture output results

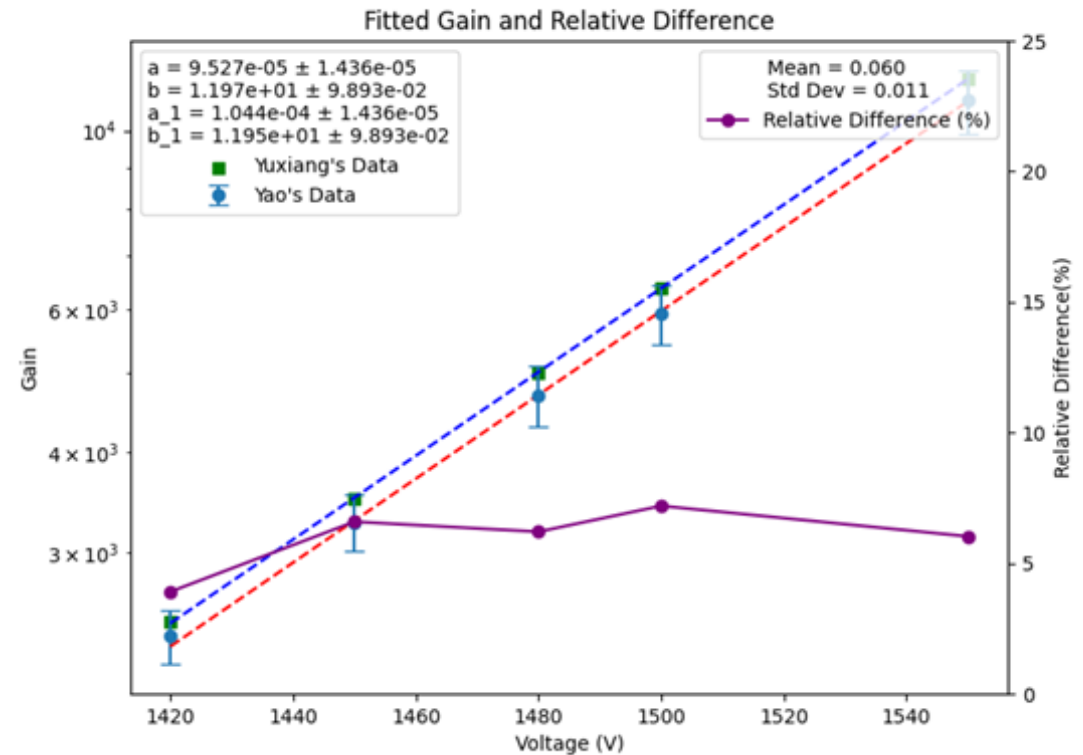
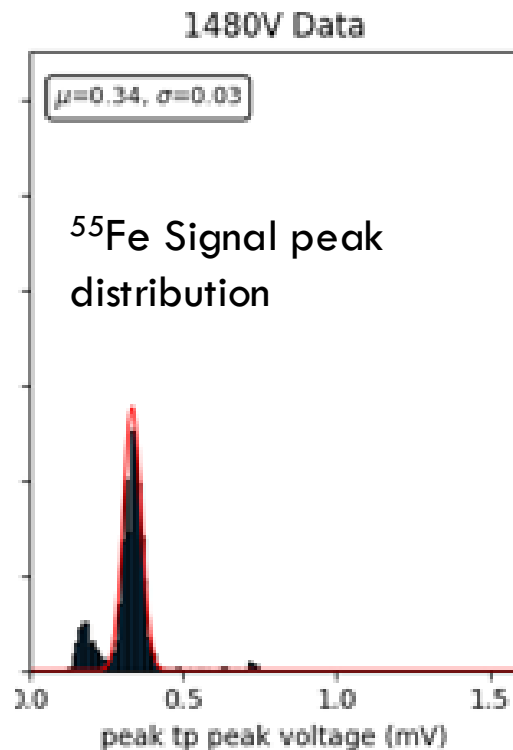

Compare between gas mixture and pre-mixed gas

Tracking resolution per tube for Ar:CO2 (70:30)

$$\sigma = \sqrt{\sigma_u \cdot \sigma_b} = 87.15 \text{ } \mu\text{m}$$

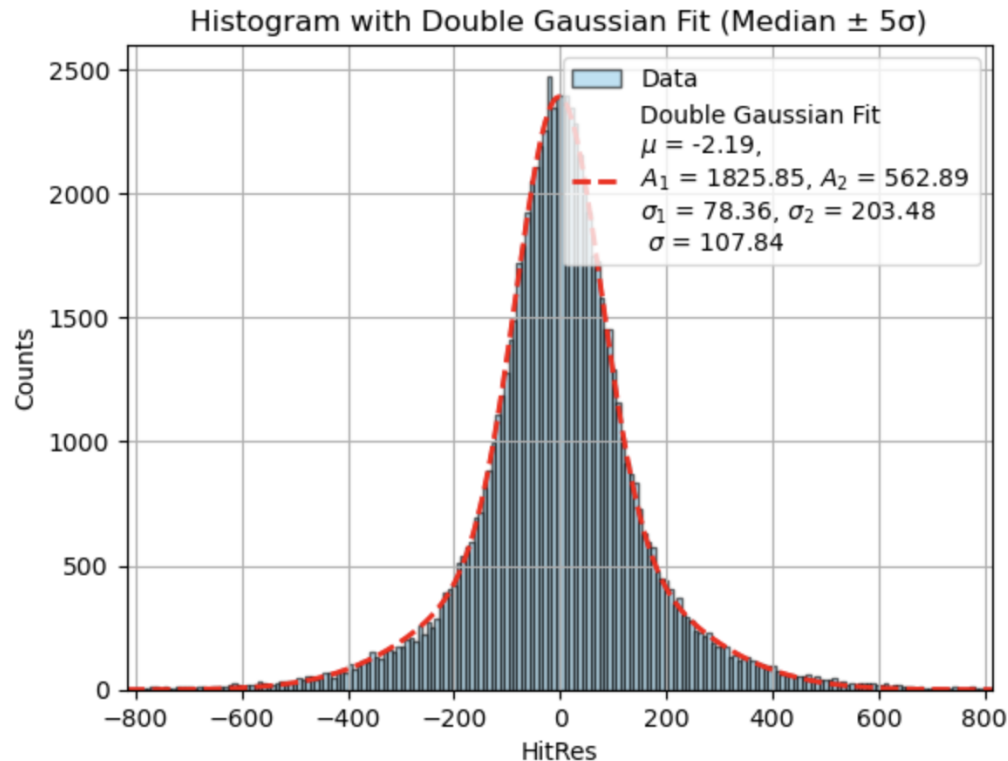

Unbiased residual distribution
(the tube under study is not included in fitting)

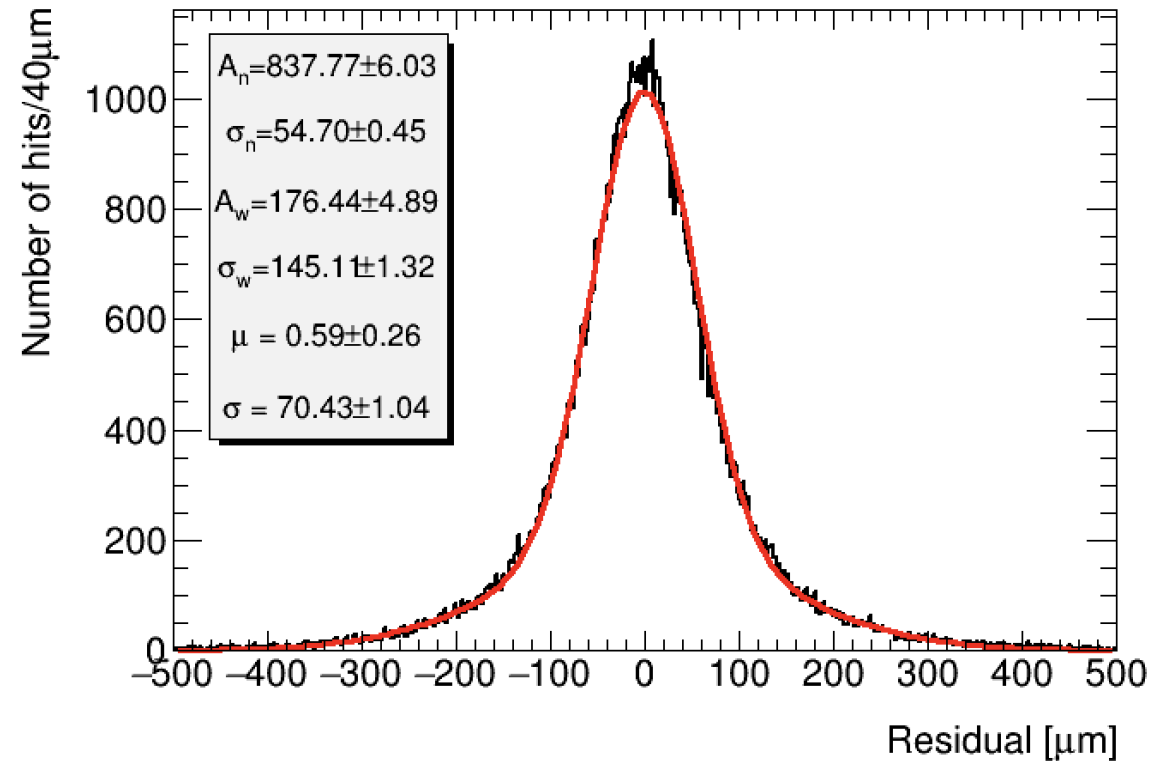

Biased residual distribution
(including all the tubes in track fitting)

Tracking resolution per tube for Ar:CO2 (80:20)

$$\sigma = \sqrt{\sigma_u \cdot \sigma_b} = 94.31 \mu\text{m}$$

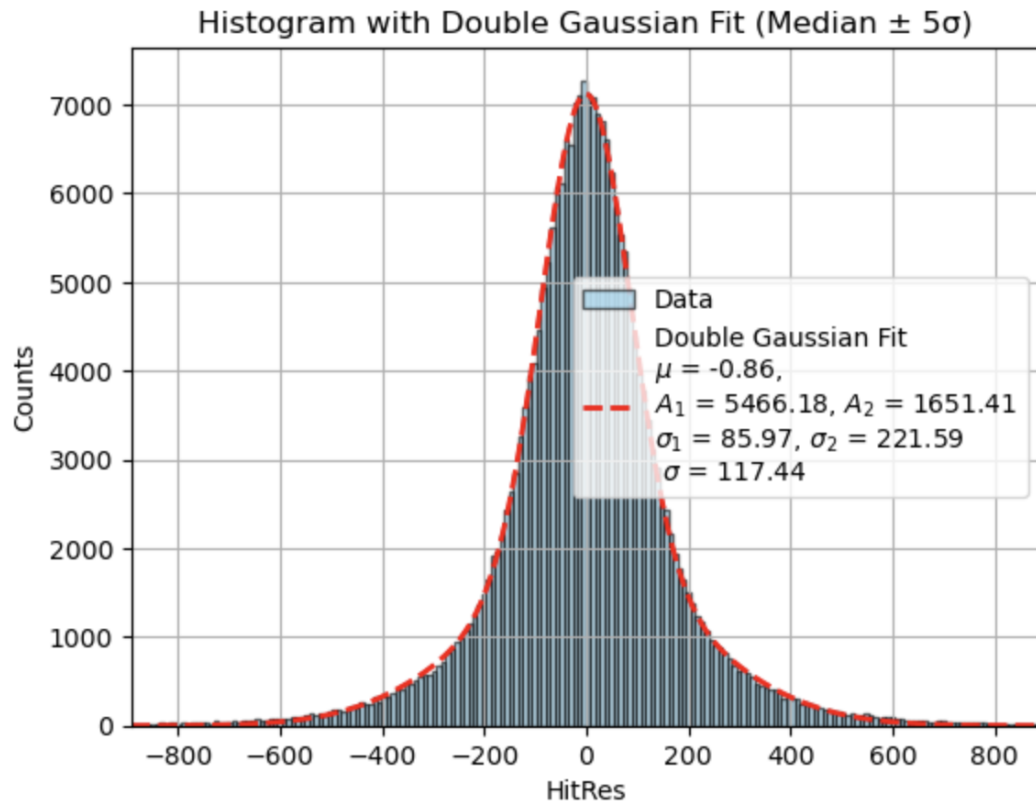

Unbiased residual distribution
(the tube under study is not included in fitting)

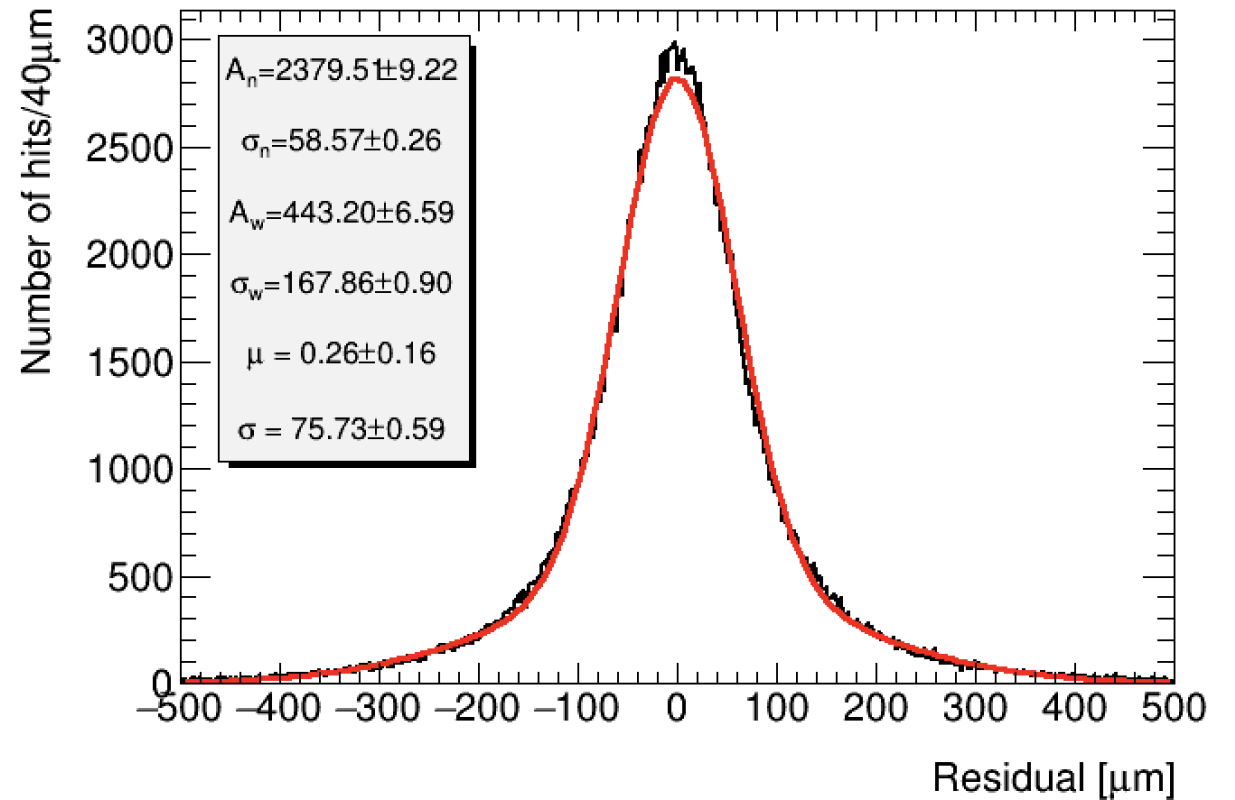

Biased residual distribution
(including all the tubes in track fitting)

Tracking resolution per tube for Ar:CO2 (93:7)

$$\sigma = \sqrt{\sigma_u \cdot \sigma_b} = 111.6 \mu\text{m}$$

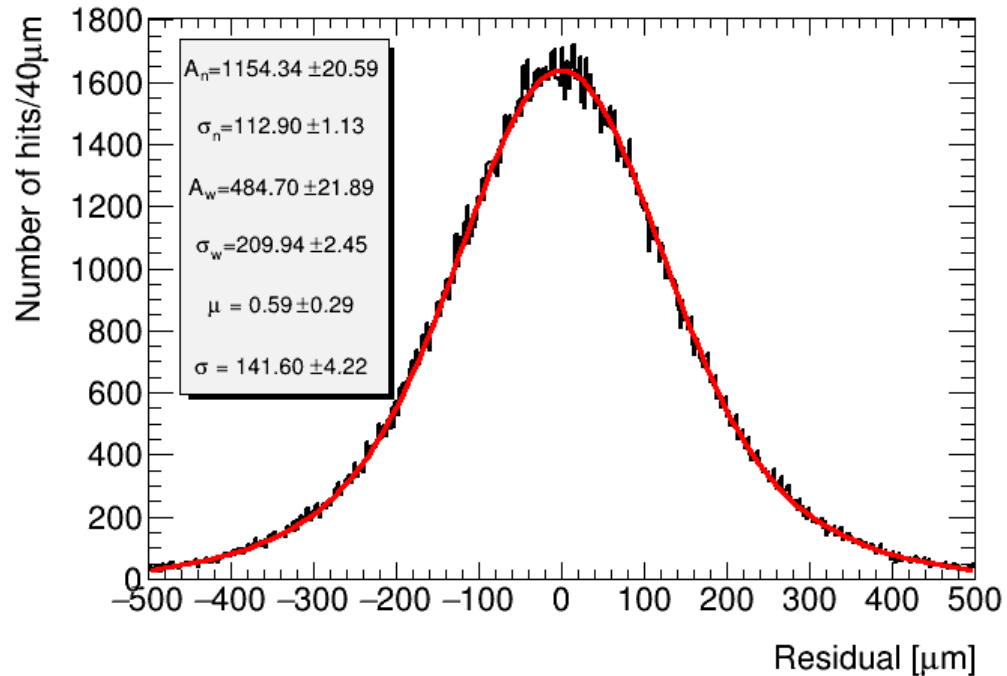

Unbiased residual distribution
(the tube under study is not included in fitting)

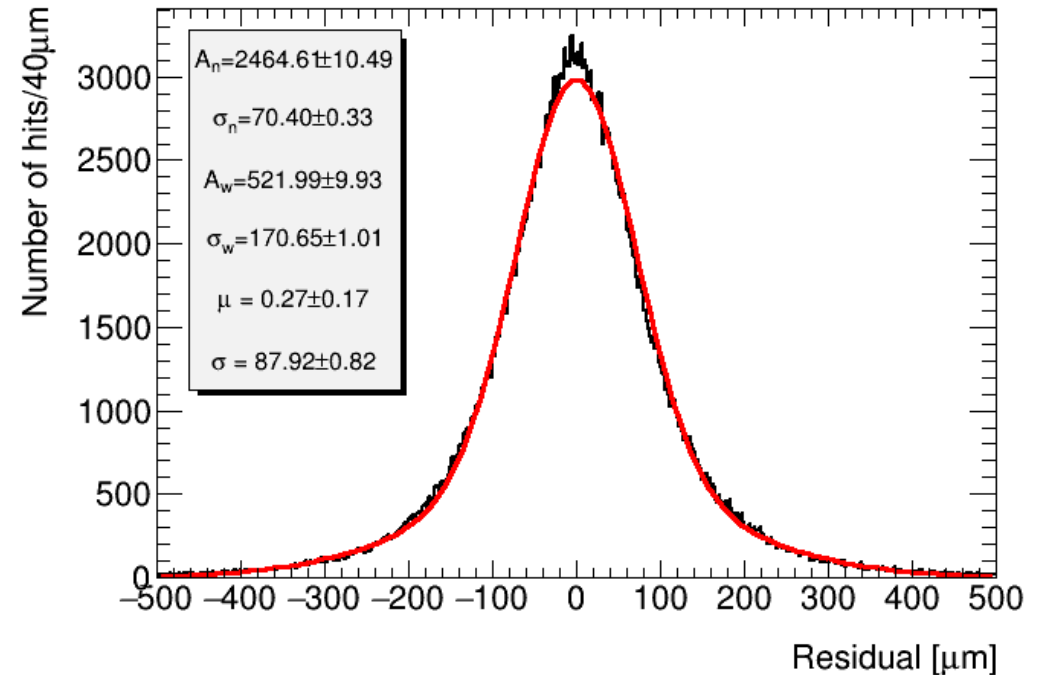

Biased residual distribution
(including all the tubes in track fitting)

Scintillator Strips to Make Prototypes

- We visited Fermilab scintillator extrusion facility and obtained >100 triangular strips
- Plan to build 2 small scintillator strip prototypes with SiPM readout to test the performance with cosmic rays and test beams
- Test beam scheduled at CERN in August and November this year

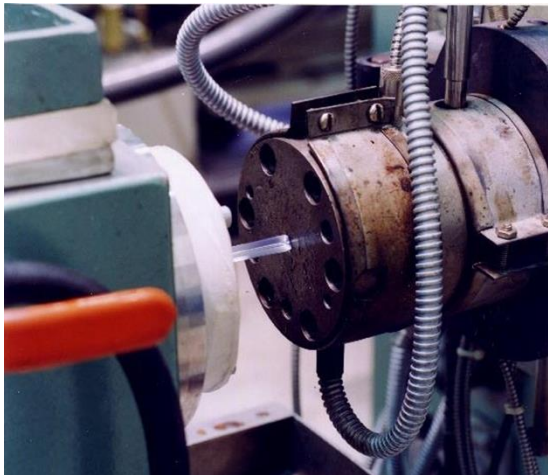

Scintillator strip extrusion at Fermilab



Strips (1 m long) brought back from Fermilab to UM to make prototypes

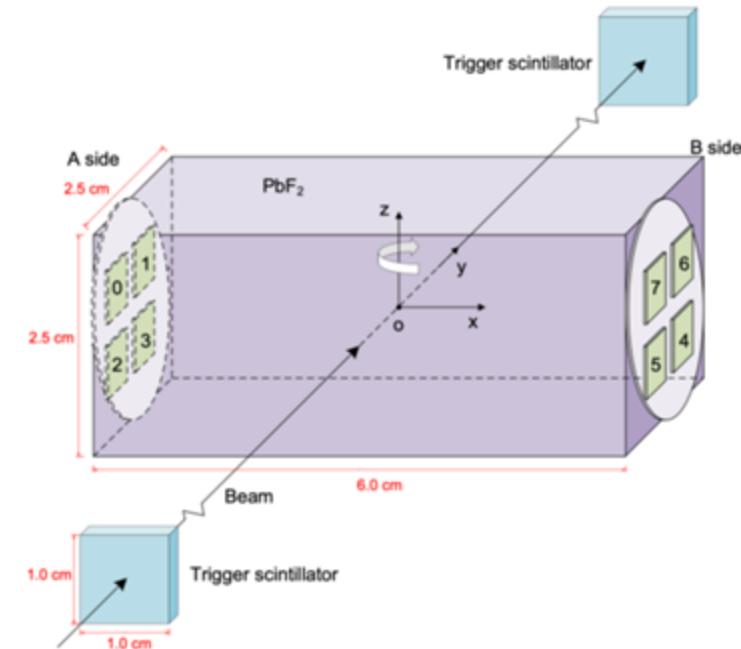

Experience with SiPM readout of FCC-ee dual readout R&D