

v_1 of ϕ in heavy ion collisions

Su Houg Lee



YONSEI
UNIVERSITY

1. Some previous STAR measurements at larger energies
2. Measurement near threshold
3. ϕ meson in medium: Sum rules, Lattice, ALICE, KEK E325
4. E-16 and E-88 experiment at JPARC
5. Some more insight

STAR Data

A talk by STAR at quark matter 25

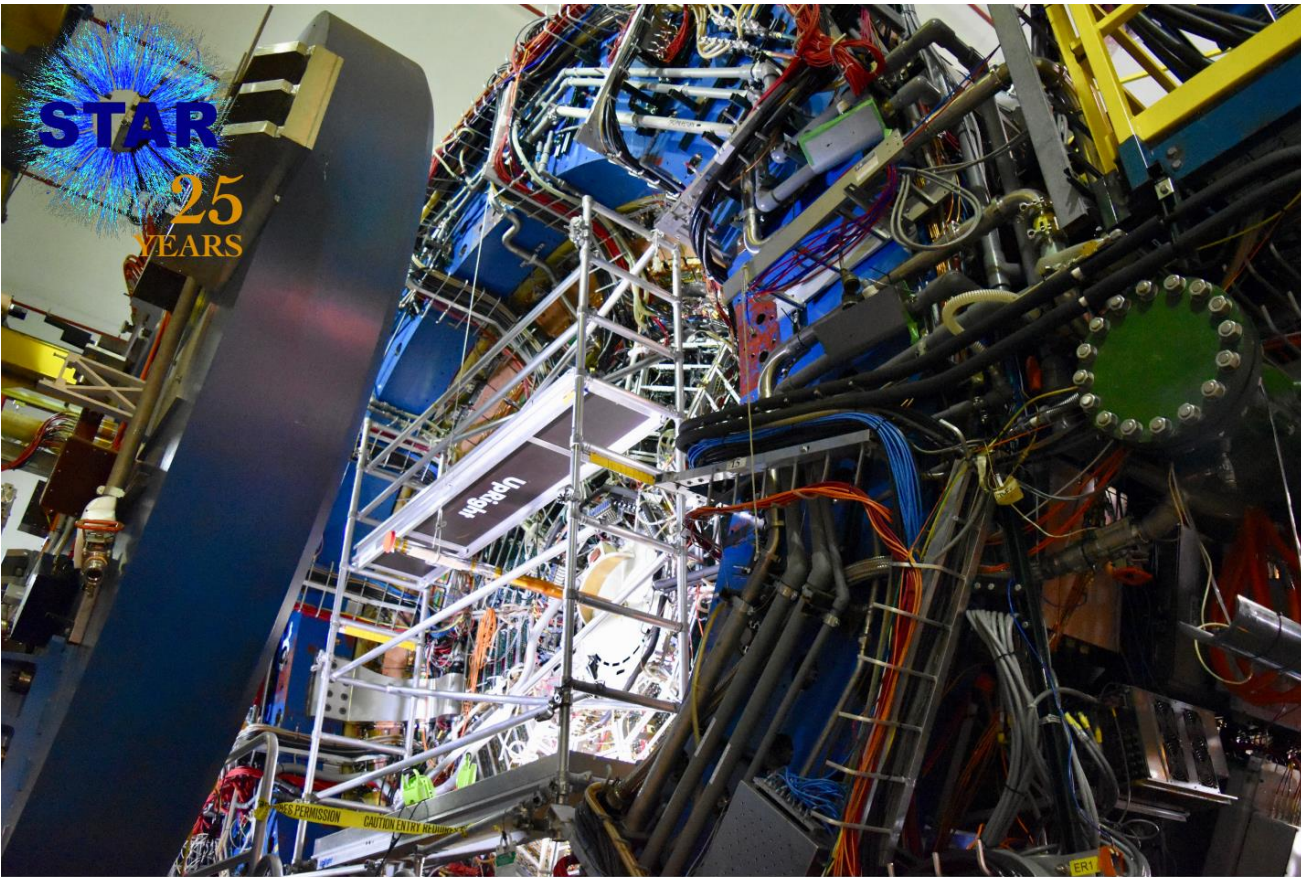

Experiment Overview: STAR

*Sooraj Radhakrishnan
(Kent State University)
for the
STAR Collaboration*

*Quark Matter 2025,
Frankfurt, Germany*

Supported in part by



U.S. DEPARTMENT OF
ENERGY

Office of
Science

KENT STATE
UNIVERSITY



Anisotropic Flow

- ❖ **Flow** is the measure of azimuthal anisotropy of particles
- ❖ **Azimuthal distribution of particles**

$$E \frac{d^3N}{dp^3} = \frac{d^2N}{2\pi p_T dp_T dy} \left\{ 1 + \sum_{n \geq 1} 2 v_n \cos [n(\phi - \Psi_n)] \right\}$$

$$v_n = \langle \cos [n(\phi - \Psi_n)] \rangle$$

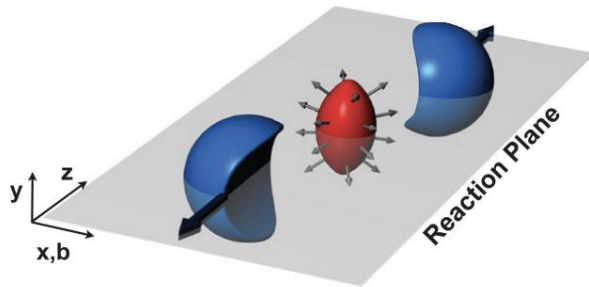

Why is v_n an important observable?

- ❖ Sensitive to the equation of state
- ❖ Sensitive to early times in the evolution of the system

R. Snellings, New J.Phys.13:055008 (2011) A. M. Poskanzer and S. A. Voloshin, Phys. Rev. C 58, 1671 (1998)

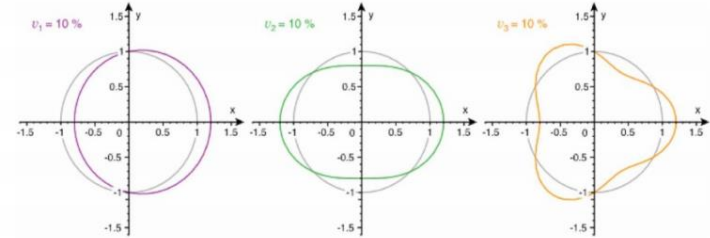

Directed flow(v_1) Elliptic flow(v_2) Triangular flow(v_3)

Directed flow

$$v_1 = \langle \cos(\phi - \Psi_1) \rangle$$

Sideward motion of emitted hadrons with respect to collision reaction plane

Elliptic flow

$$v_2 = \langle \cos(2(\phi - \Psi_2)) \rangle$$

Driven by the initial spatial asymmetry of the overlap region

Triangular flow

$$v_3 = \langle \cos 3(\phi - \Psi_3) \rangle$$

Driven by the shape of the initial collision geometry at low collision energies

Motivation: Directed flow (v_1)

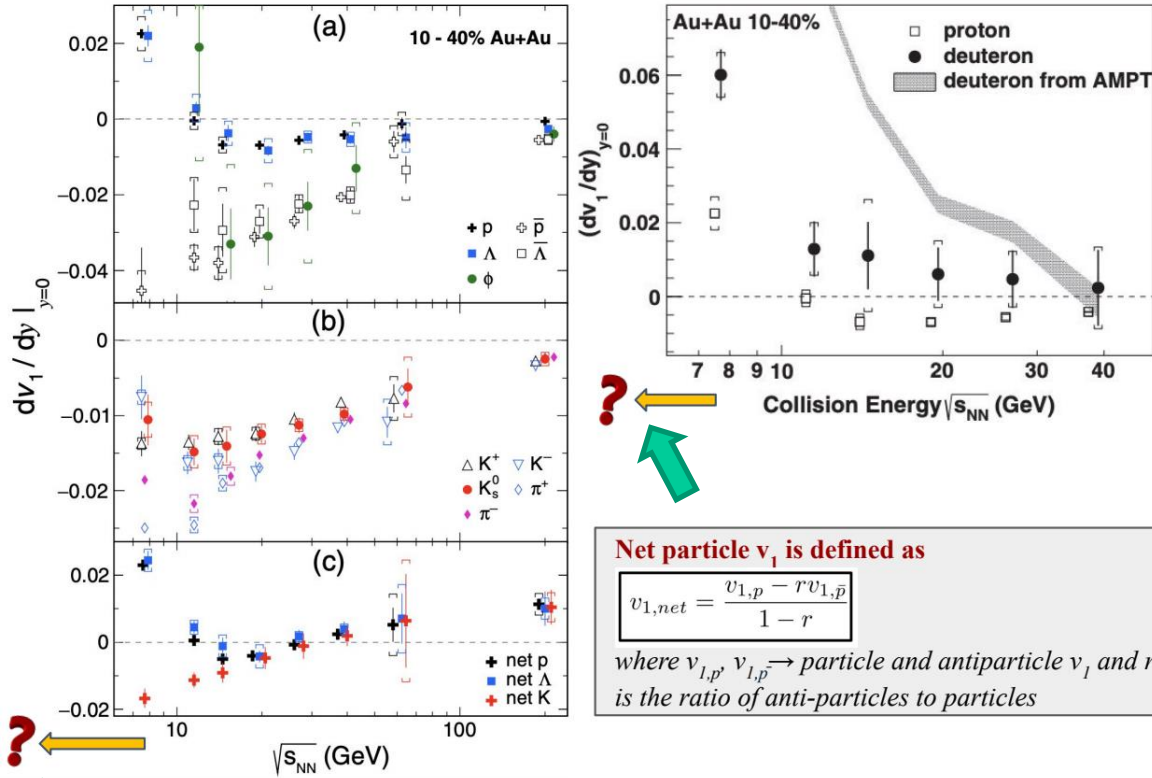

Net particle v_1 is defined as

$$v_{1,net} = \frac{v_{1,p} - r v_{1,\bar{p}}}{1 - r}$$

where $v_{1,p}$, $v_{1,\bar{p}}$ → particle and antiparticle v_1 and r is the ratio of anti-particles to particles

- ❖ dv_1/dy for proton contrary to mesons showed a non-monotonic trend as function of collision energy → **Change of sign**
- ❖ **Net particle** (the excess of a particle over antiparticle) gives contribution of transported quarks w.r.t produced
- ❖ Observed minima in v_1 slope of net-p and net- Λ between 11.5 and 19.6 GeV, *no minima observed for net-K*
- ❖ Light nuclei $d(v_1/A)/dy$ within systematic and statistical uncertainties → **test for nucleon coalescence mechanism**

STAR: Phys. Rev. Lett. 120, 062301 (2018); STAR: Phys. Rev. C 102, 044906 (2020)



Previous work: explained by separate flow of q and \bar{q} → coalescence

Directed flow of identified hadrons

- Directed flow sensitive probe of early time interactions and EoS

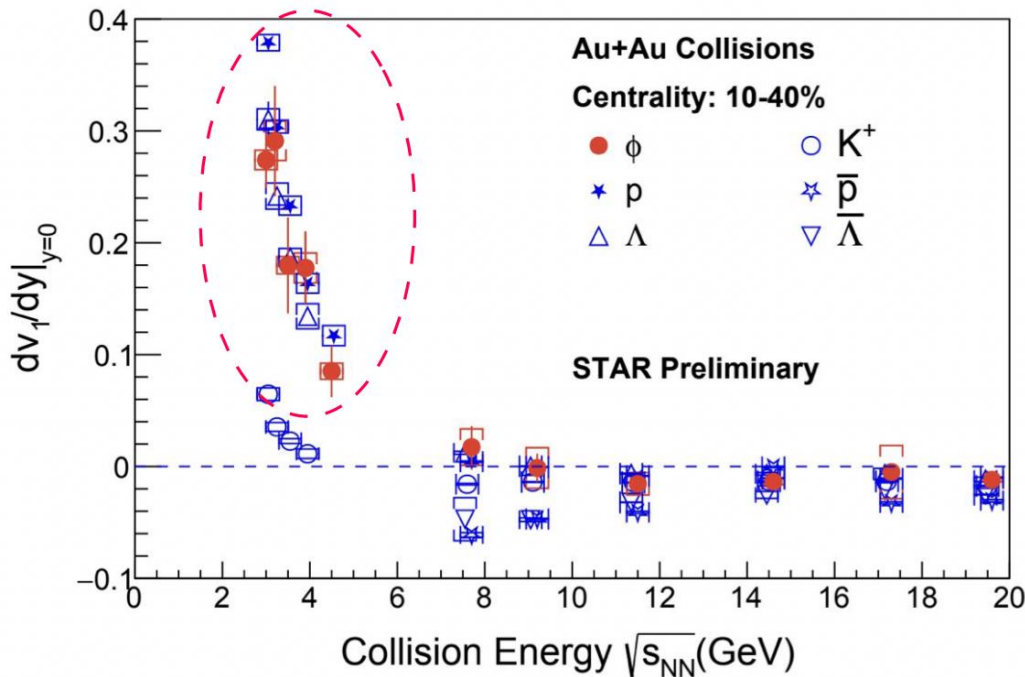

- Precision measurement of v_1 of various identified particles across the collision energies
- Kaons show sign change as protons, but with minimum between 4.5 and 7.7 GeV
- Unexpectedly large v_1 for ϕ mesons in the high μ_B region, similar v_1 as protons and Λ !



Near threshold via hadronic interaction $N + N \rightarrow N + N^* (> 1960 \text{ MeV}) \rightarrow N + (N + \phi)$

But no $N^* (> 1960 \text{ MeV})$ with $(N + \phi)$ decay in Particle data book

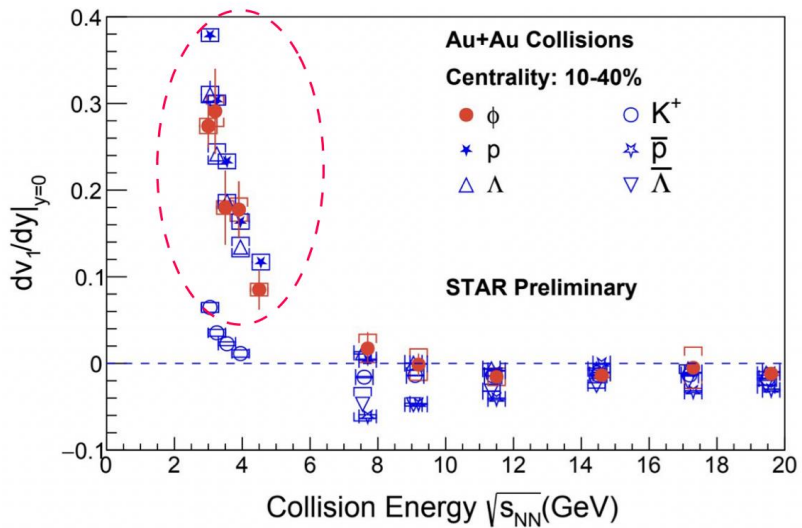

$N(1650)$ DECAY MODES

The following branching fractions are our estimates, not fits or averages.

| Mode | Fraction (Γ_i/Γ) |
|--|--------------------------------|
| Γ_1 $N\pi$ | 50–70 % |
| Γ_2 $N\eta$ | 15–35 % |
| Γ_3 ΛK | 5–15 % |
| Γ_4 $N\pi\pi$ | 20–58 % |
| Γ_5 $\Delta(1232)\pi$, D -wave | 6–18 % |
| Γ_6 $N\rho$ | 12–22 % |
| Γ_7 $N\rho$, $S=1/2$, S -wave | <4 % |
| Γ_8 $N\rho$, $S=3/2$, D -wave | 12–18 % |
| Γ_9 $N\sigma$ | 2–18 % |
| Γ_{10} $N(1440)\pi$ | 6–26 % |
| Γ_{11} $p\gamma$, helicity=1/2 | 0.04–0.20 % |
| Γ_{12} $n\gamma$, helicity=1/2 | 0.003–0.17 % |

Also, why no K^+ →

ϕ -N interaction, or ϕ in medium

- ϕ - N potential: Lattice

□ Long range part: attraction $2\text{-}\pi$

$$V(r \gg (2m_\pi)^{-1}) = -\alpha \frac{\exp(-2m_\pi r)}{r^2}, \quad \alpha \approx 91 \text{ MeV} \cdot \text{fm}^2$$

$$\Delta E_{2\pi-N} \approx \rho_{n.m} \int_{r_0} -\alpha \frac{\exp(-2m_\pi r)}{r^2} d^3x \leq 10 \text{ MeV}$$

→ Coupling to $2\text{-}\pi$

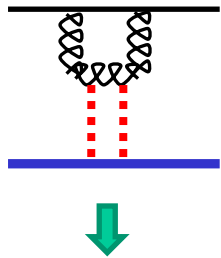

Not present in sum rules

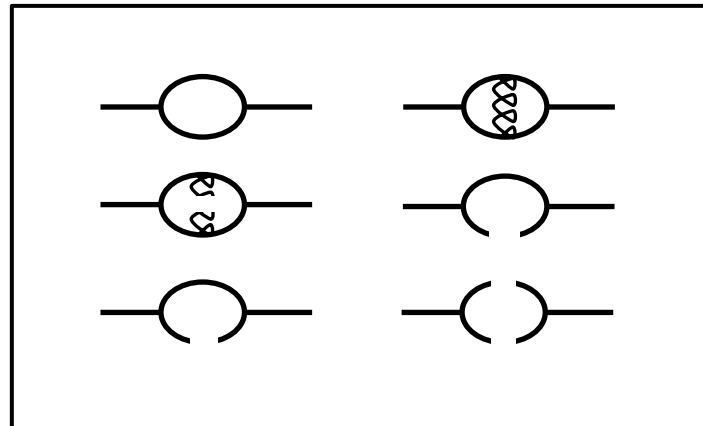

Y. Lyu et al (HAL) PRD106,074507(22)

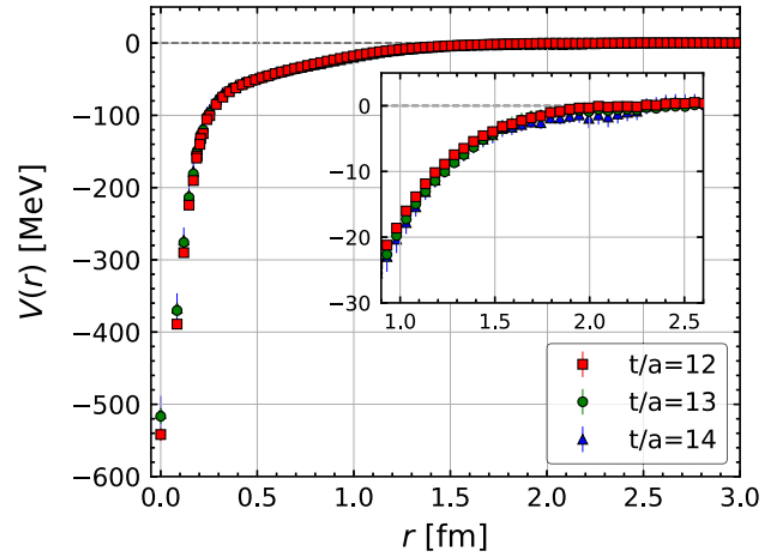
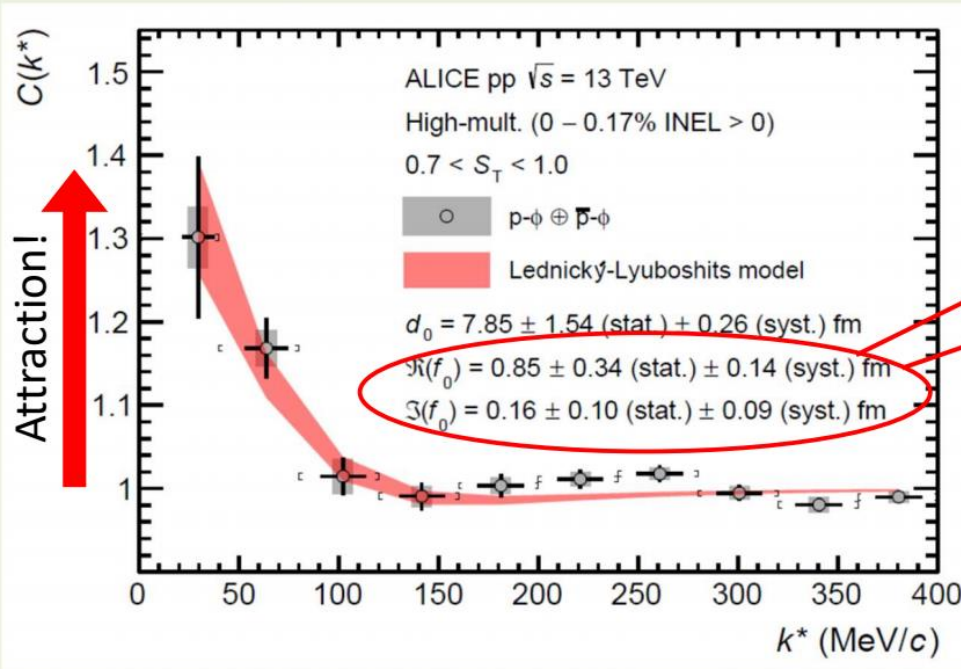

FIG. 1. The N - ϕ potential $V(r)$ in the ${}^4S_{3/2}$ channel as a function of separation r at Euclidean time $t/a = 12$ (red squares), 13 (green circles), and 14 (blue triangles).

- ϕ -N correlation: ALICE

ALICE: pp

ϕ N correlation function



★ Strongly attractive

★ Small absorption

Caution:

Spin averaged value with
 non-trivial weights
 (thanks to Kamiya-san!)

S. Acharya et al. (ALICE Coll.), Phys. Rev. Lett. **127**, 172301 (2021).

$$V_\phi(\rho) = -\frac{2\pi}{m_\phi} \rho \left(1 + \frac{m_\phi}{m_N}\right) a_0$$

$$\simeq -85 \frac{\rho}{\rho_0} \left(\frac{a_0}{\text{fm}}\right) \text{MeV}$$

- ϕ -in medium: KEK E325

Previous experimental results

KEK
E325

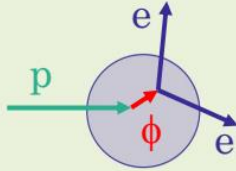

12 GeV
pA-reaction

slow ϕ s

Pole mass:

$$\frac{m_\phi(\rho)}{m_\phi(0)} = 1 - k_1 \frac{\rho}{\rho_0}$$

0.034 ± 0.007

intermediate
 ϕ s

Pole width:

$$\frac{\Gamma_\phi(\rho)}{\Gamma_\phi(0)} = 1 + k_2 \frac{\rho}{\rho_0}$$

2.6 ± 1.5



Measurement is being repeated with
 $\sim 100x$ increased statistics at the
J-PARC E16 experiment!

fast ϕ s

$$\beta\gamma = \frac{|\vec{p}|}{m_\phi}$$

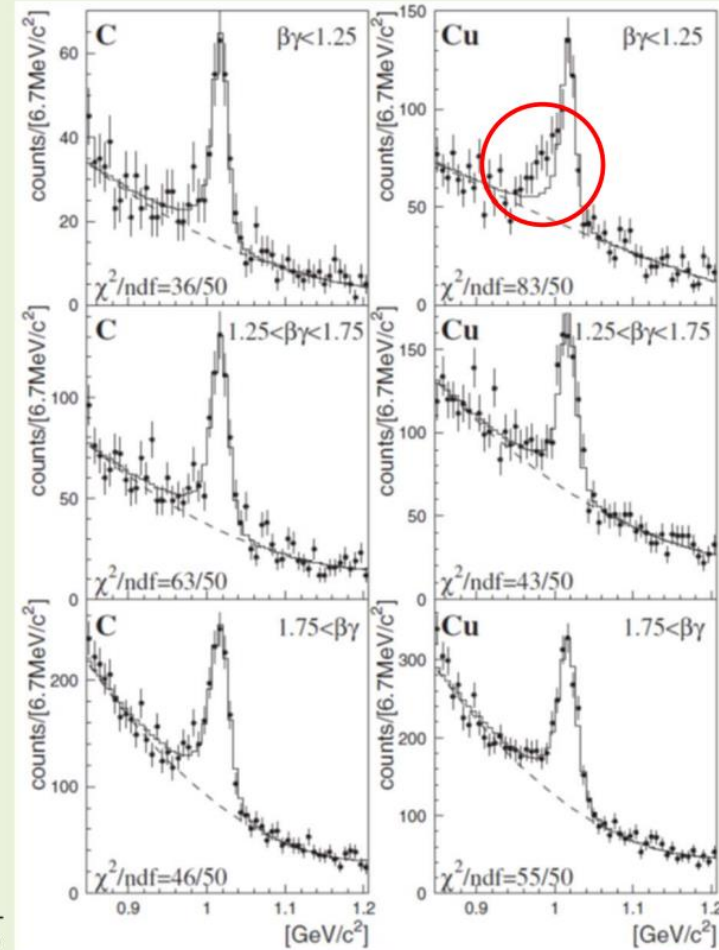

R. Muto et al. (E325 Collaboration), Phys. Rev. Lett. **98**, 042501 (2007).

- J/ψ-N potential: Lattice*

□ Long range part: attraction 2-π

$$V(r \gg (2m_\pi)^{-1}) = -\alpha \frac{\exp(-2m_\pi r)}{r^2}, \quad \alpha \approx 22, 23 \text{ MeV} \cdot \text{fm}^2$$

$$\Delta E_{2\pi-N} \approx \rho_{n,m} \int_{1\text{fm}} -\alpha \frac{\exp(-2m_\pi r)}{r^2} d^3x \leq 7 \text{ MeV}$$

→ Coupling to 2-π

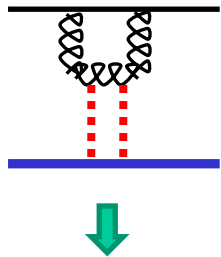

Not present in sum rules

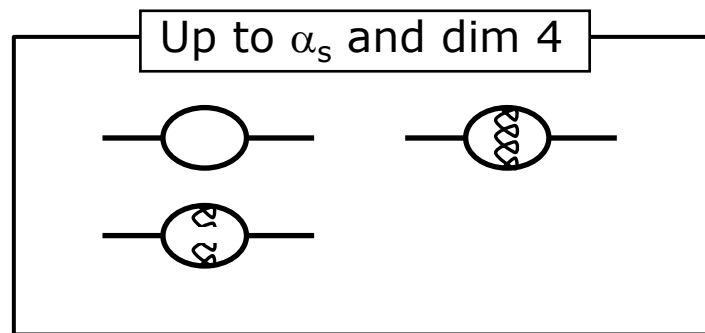

Y. Lyu et al (HAL) PLB860,139178(25)

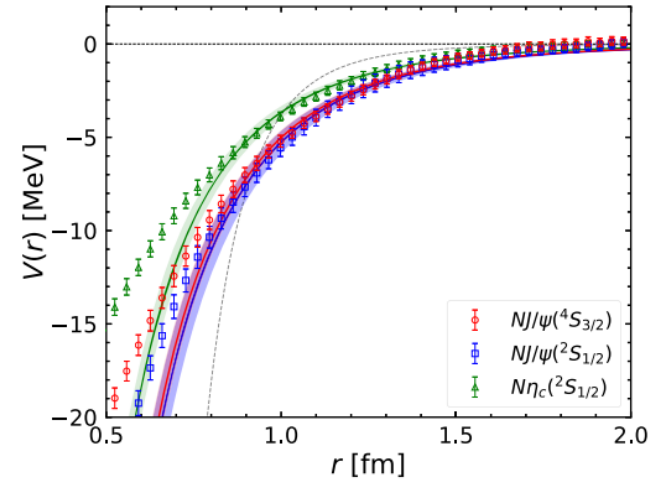

Fig. 2. The bands show the fit with the TPE function $V(r) = -\alpha e^{-2m_\pi r}/r^2$ to the long-range $N-c\bar{c}$ potential. The gray dashed line is the best fit with $V(r) = -\alpha/r^7$ for comparison.

□ Up to dim 6

| | Spin=0 | Spin=2 | Spin=4 |
|-------|---|--|--|
| Dim 4 | $g^2 G_{\mu\nu}^a G_{\mu\nu}^a$ | $g^2 G_{\alpha\mu}^a G_{\beta\mu}^a$ | |
| Dim 6 | $g^3 f^{abc} G_{\mu\nu}^a G_{\mu\alpha}^b G_{\nu\alpha}^c$ $g^2 D_\mu G_{\mu\alpha}^a D_\nu G_{\nu\alpha}^a$ | $g^2 D_\alpha G_{\mu\nu}^a D_\beta G_{\mu\nu}^a$ $g^2 D_\alpha G_{\beta\mu}^a D_\nu G_{\mu\nu}^a$ $g^2 D_\mu G_{\alpha\mu}^a D_\nu G_{\beta\nu}^a$ | $g^2 G_{\alpha\mu}^a D_\chi D_\delta G_{\beta\mu}^a$ |

But note $D_\nu G_{\mu\nu}^a = g \left(\bar{q} \gamma_\mu \frac{\lambda^a}{2} q \right)$

$g^4 \left(\bar{q} \gamma_\alpha \frac{\lambda^a}{2} q \right) \left(\bar{q} \gamma_\alpha \frac{\lambda^a}{2} q \right)$

$g^4 \left(\bar{q} \gamma_\alpha \frac{\lambda^a}{2} q \right) \left(\bar{q} \gamma_\beta \frac{\lambda^a}{2} q \right)$

Higher order in α but can couple to $2-\pi$

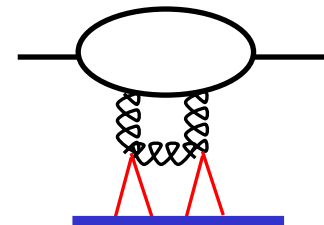

□ Contribution of 4-quark operator in J/ψ

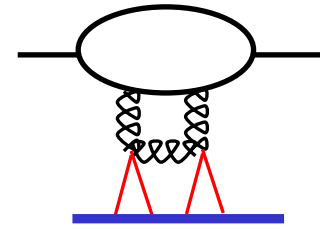

$$\left\langle g^4 \left(\bar{q} \gamma_\alpha \frac{\lambda^a}{2} q \right) \left(\bar{q} \gamma_\alpha \frac{\lambda^a}{2} q \right) \right\rangle$$

Also appears in $\rho - a_1$ sum rule (but to α): can separate into chiral symmetric and breaking parts

- Vacuum saturation (only chiral symmetry breaking part contributes)

$$\left\langle \left(\bar{q} \gamma_\alpha \frac{\lambda^a}{2} q \right) \left(\bar{q} \gamma_\alpha \frac{\lambda^a}{2} q \right) \right\rangle \rightarrow -\frac{8}{9} \langle \bar{q} q \rangle^2$$

- Fiertz transformation to extract 2- π contribution

$$\left\langle \left(\bar{q} \gamma_\alpha \frac{\lambda^a}{2} q \right) \left(\bar{q} \gamma_\alpha \frac{\lambda^a}{2} q \right) \right\rangle \rightarrow \sum_{i,j=u,d} \left(\dots + 2 \langle (\bar{q}_i \gamma_5 q_j) (\bar{q}_j \gamma_5 q_i) \rangle + \langle (\bar{q}_i \gamma_5 \gamma_\mu q_j) (\bar{q}_j \gamma_5 \gamma_\mu q_i) \rangle \right) \rightarrow +\frac{1}{6} \langle \bar{q} q \rangle^2$$

- Use linear density part of the chiral symmetry breaking operators
 \rightarrow 2- π and 2-K contributions leads to small attraction around 1 MeV

- ϕ -N potential: Lattice

□ Long range part: attraction $2-\pi$

$$V(r \ll (2m_\pi)^{-1}) = -\alpha \frac{\exp(-2m_\pi r)}{r^2}, \quad \alpha \approx 91 \text{ MeV} \cdot \text{fm}^2$$

$$\Delta E_{2\pi-N} \approx \rho_{n.m} \int_{r_0} -\alpha \frac{\exp(-2m_\pi r)}{r^2} d^3x \leq 30 \text{ MeV}$$

→ Coupling to $2-\pi$

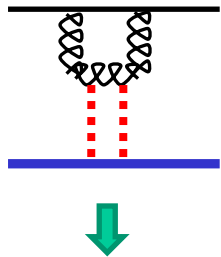

Not present in sum rules

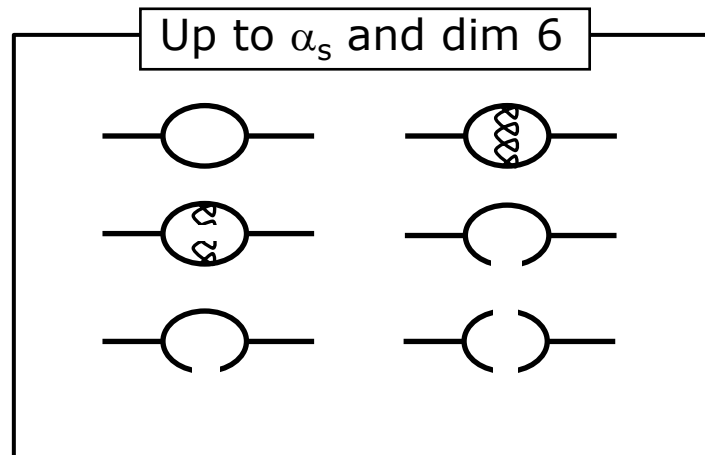

Y. Lyu et al (HAL) PRD106,074507(22)

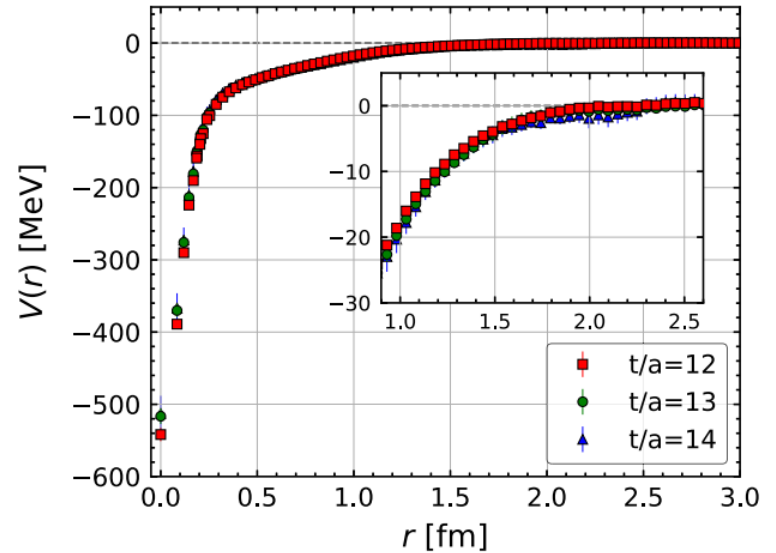
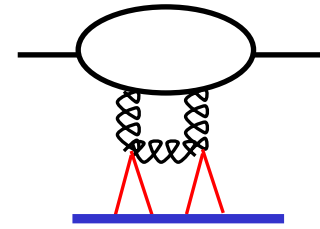

FIG. 1. The N - ϕ potential $V(r)$ in the ${}^4S_{3/2}$ channel as a function of separation r at Euclidean time $t/a = 12$ (red squares), 13 (green circles), and 14 (blue triangles).

□ Contribution of 4-quark operator in ϕ



$$\left\langle g^4 \left(\bar{q} \gamma_\alpha \frac{\lambda^a}{2} q \right) \left(\bar{q} \gamma_\alpha \frac{\lambda^a}{2} q \right) \right\rangle$$

Wilson coefficient is more complicated

- Naïve extension of J/ψ sum rules to ϕ gives larger attraction
- But Wilson coefficient is more complicated

$$\left\langle \left(\bar{q} \gamma_\alpha \frac{\lambda^a}{2} q \right) \left(\bar{q} \gamma_\alpha \frac{\lambda^a}{2} q \right) \right\rangle \rightarrow \sum_{i,j=u,d} \left(\dots + 2 \left\langle \left(\bar{q}_i \gamma_5 q_j \right) \left(\bar{q}_j \gamma_5 q_i \right) \right\rangle + \left\langle \left(\bar{q}_i \gamma_5 \gamma_\mu q_j \right) \left(\bar{q}_j \gamma_5 \gamma_\mu q_i \right) \right\rangle \right) \rightarrow + \frac{1}{6} \langle \bar{q} q \rangle^2$$

- Use linear density part of the chiral symmetry breaking operators
 - $2-\pi + 2-K$ contribution leads to attraction of around (less reliable) 2 MeV
 - Chiral symmetric operators should be non-trivial

ϕ -in medium: JPARC E-16 and E-88

E-16: $\phi \rightarrow e^+ e^-$ decay

E-88 : $\phi \rightarrow K^+ K^-$ decay



Contents lists available at [ScienceDirect](https://www.sciencedirect.com)

Journal of Subatomic Particles and Cosmology

journal homepage: <https://www.sciencedirect.com/journal/journal-of-subatomic-particles-and-cosmology>

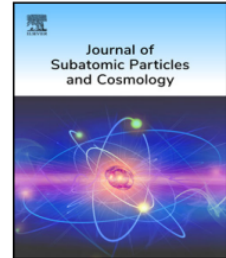

Full Length Article

Experimental investigation of vector mesons in medium through dielectron decay at J-PARC

Kazuya Aoki^{a,*}, Sakiko Ashikaga^b, Wen-Chen Chang^c, Tatsuya Chujo^d, Ren Ejima^e, Hideto En'yo^f, Shinichi Esumi^d, Dairon Rodriguez Garces^{g,h}, Hideki Hamagakiⁱ, Johann M. Heuser^h, Ryotaro Honda^a, Masaya Ichikawa^a, Daichi Ishii^j, Shunsuke Kajikawa^k, Jo Kakunaga^l, Koki Kanno^a, Akio Kiyomichi^m, Yusuke Hori^j, Chih-Hsun Lin^c, Yuhei Morino^a, Tomoki N. Murakami^f, Ryotaro Muto^a, Shunnosuke Nagafusa^j, Wataru Nakai^a, Satomi Nakasuga^j, Megumi Naruki^j, Toshihiro Nonaka^d, Hiroyuki Noumi^b, Shuta Ochiai^j, Makoto Ogura^j, Kyoichiro Ozawa^a, Adrian Rodriguez Rodriguez^h, Takao Sakaguchiⁿ, Hiroyuki Sako^o, Fuminori Sakuma^f, Susumu Sato^o, Shinya Sawada^a, Michiko Sekimoto^a, Kenta Shigaki^e, Kotaro Shirotori^b, Hitoshi Sugimura^a, Tomonori N. Takahashi^b, Tomohiro Taniguchi^j, Maksym Teklishyn^h, Alberica Toia^{g,h}, Rento Yamada^e, Kanako H. Yamaguchi^j, Yorito L. Yamaguchi^e, Shogo Yanai^j, Satoshi Yokkaichi^f

Table 1

E16 Run History and Plan. The first number on the rightmost column indicates the number of STS modules if associated with †; otherwise, it indicates the number of old SSD modules that were used for earlier runs. *Two out of ten GTR modules are only equipped with GTR1 and GTR2.

| Run | Year | User time | Targets | Configuration SSD+GTR+ HBD+LG |
|--------|-----------|-----------|----------------------------|-------------------------------------|
| Run 0a | Jun. 2020 | 159 h | C, Cu | 6+6+4+6 |
| Run 0b | Feb. 2021 | 110 h | C, Cu | 6+8+6+6 |
| Run 0c | May. 2021 | 134 h | C, Cu | 6+8+6+6 |
| Run 0d | Jun. 2023 | 10.5 h | C, Cu | 10 [†] +10*+8+8 |
| Run 0e | Apr. 2024 | 206 h | C, Cu | 8 [†] +10*+8+8 |
| Run 1 | TBD | 1280 h | C, Cu | 10 [†] +10*+8+8 |
| Run 2 | TBD | 2560 h | C, Cu, Pb, CH ₂ | 26 [†] +26+26+26 |

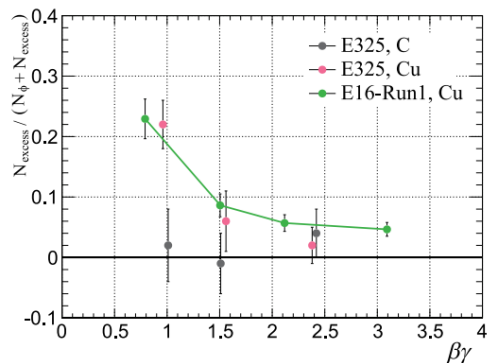

Fig. 6. Excess fraction plotted as a function of $\beta\gamma$ of ϕ mesons. Black (pink) points are the results for the C (Cu) target measured by KEK-E325 experiment [7]. Green points are the expectation in Run 1 [26]. (For interpretation of the references to color in this figure legend, the reader is referred to the web version of this article.)

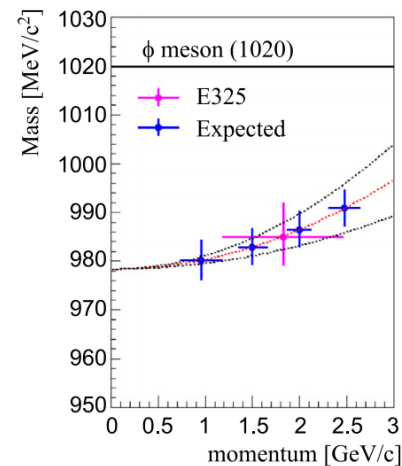

Fig. 7. Dispersion relation. Pink point represents the E325 results. Blue points depict the expectation when 1.7 times Run 1 statistics are collected. Dotted lines show a theoretical prediction extrapolated up to 3 GeV/c. [26]. (For interpretation of the references to color in this figure legend, the reader is referred to the web version of this article.)

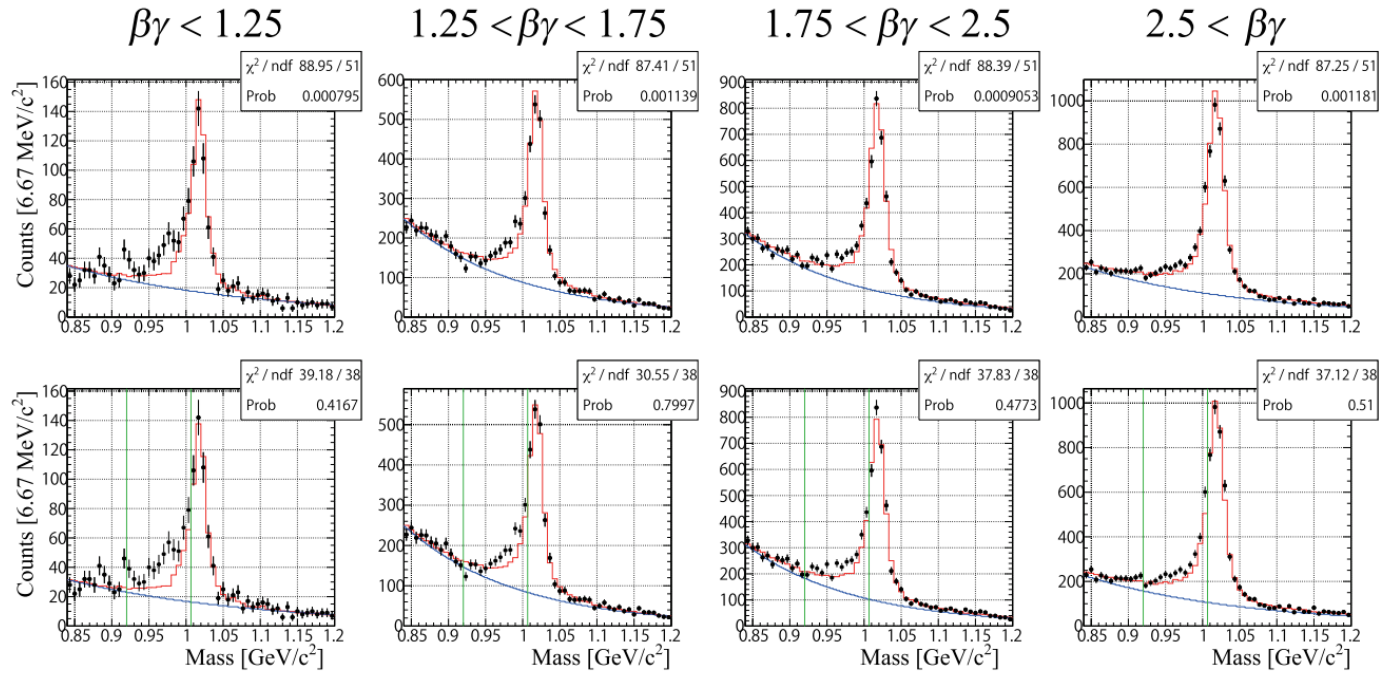

Fig. 5. Invariant mass distributions expected in Run 1. The plots are divided into four samples according to $\beta\gamma$ of the e^+e^- pairs. Black points are expected in Run 1. Red lines show the expected line shape assuming the vacuum shape. The upper four panels are obtained when the data is fitted for the entire region, while the lower four panels are obtained when the area between the green lines is eliminated from the fit. [26]. (For interpretation of the references to color in this figure legend, the reader is referred to the web version of this article.)

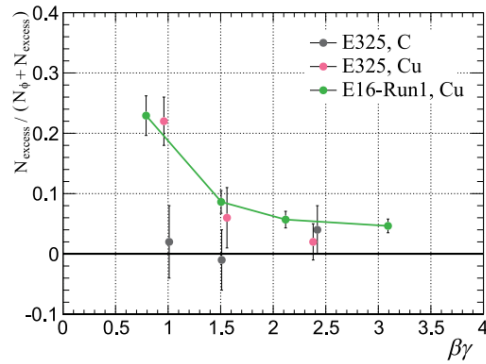

Fig. 6. Excess fraction plotted as a function of $\beta\gamma$ of ϕ mesons. Black (pink) points are the results for the C (Cu) target measured by KEK-E325 experiment [7]. Green points are the expectation in Run 1 [26]. (For interpretation of the references to color in this figure legend, the reader is referred to the web version of this article.)

Research activities (experiment)

$\phi \rightarrow K^+K^-$ experiment with E16 spectrometer (E88)

As a results of this Reimei Program, we won Kakenhi Kiban S.
1.6B yen in JFY2025-2029

The budget for E88 is secured.

Experimental Setup

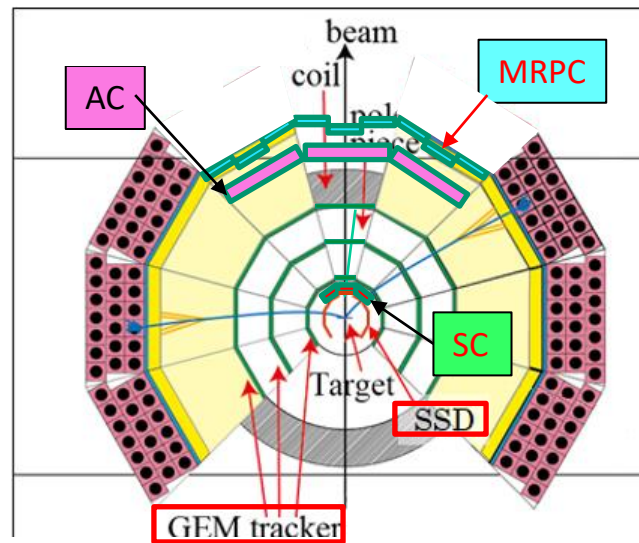

Acceptance (p+Cu)

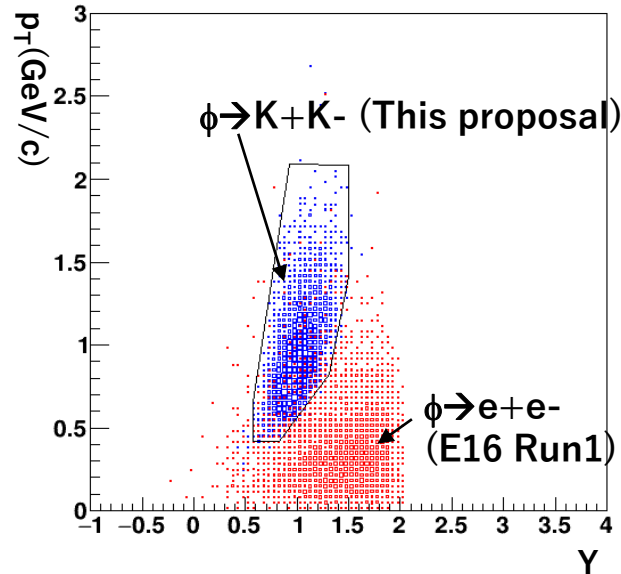

K decay angle vs momentum

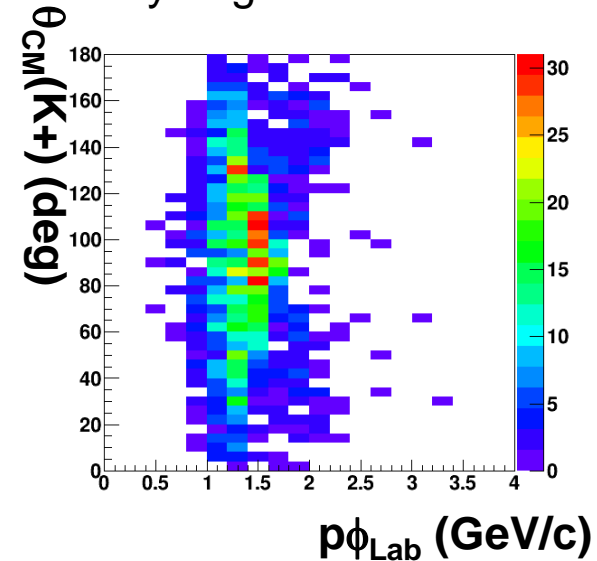

- High-statistics invariant mass spectrum measurements (800x KEK-E325)
 - 1M $\phi \rightarrow K^+K^-$ events in p+C, p+Cu and p+Pb in 30-day
 - Good acceptance overlap with $\phi \rightarrow e^+e^-$
- Kaon-ID detectors (Multi-layer Resistive Plate Chamber (MRPC), Aerogel Cherenkov detector (AC), and Start Timing Counter (SC))
- ~100% acceptance for Kaon decay angles in $\phi \rightarrow K^+K^-$ to distinguish ϕ polarization

Chiral symmetry restoration and hadron mass

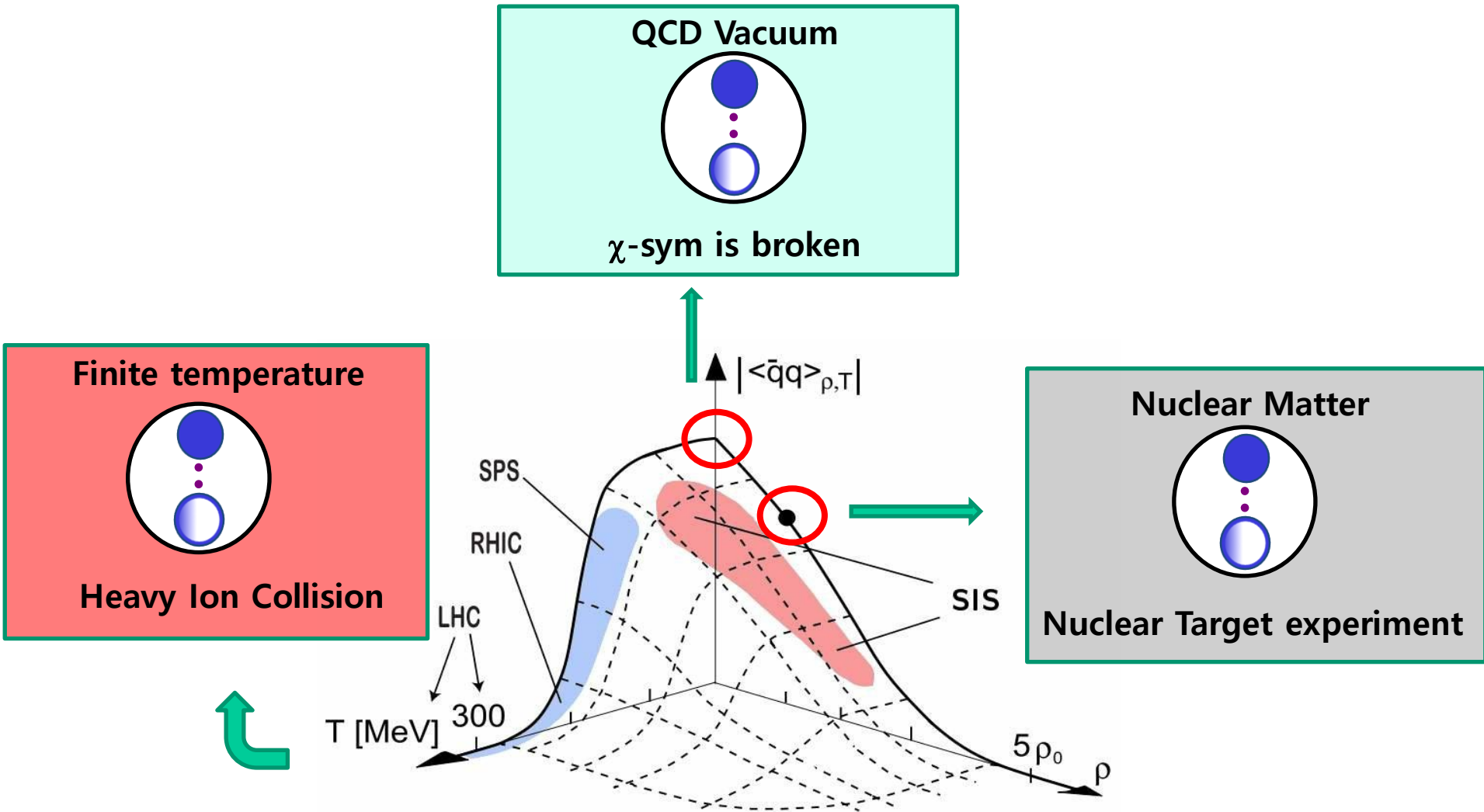

Vector meson in Flavor SU(3) symmetry and broken symmetry

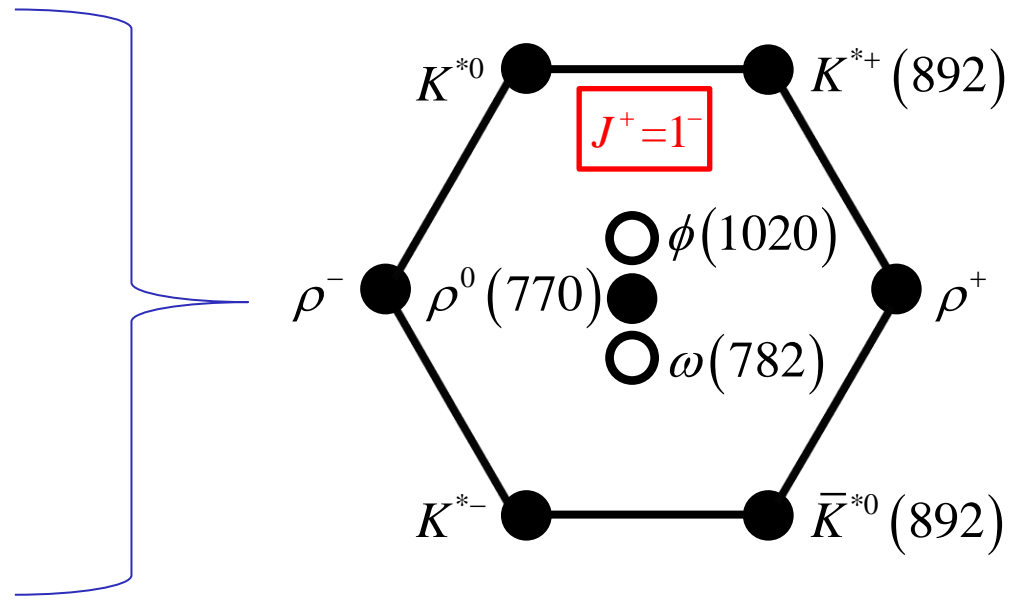
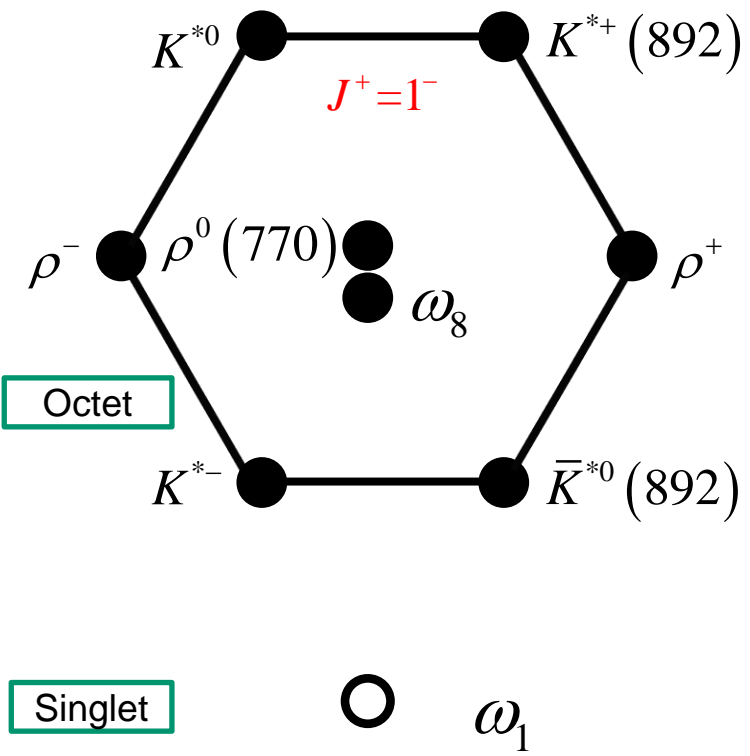

$$\omega_1 = \frac{1}{\sqrt{3}}(\bar{u}u + \bar{d}d + \bar{s}s)$$

$$\omega_8 = \frac{1}{\sqrt{6}}(\bar{u}u + \bar{d}d - 2\bar{s}s)$$

Mixing due to $m_s \gg m_d \sim m_u$

$$\phi(1020) = \bar{s}s$$

$$\omega(782) = \frac{1}{\sqrt{2}}(\bar{u}u + \bar{d}d)$$

Spin-1 Flavor Octet

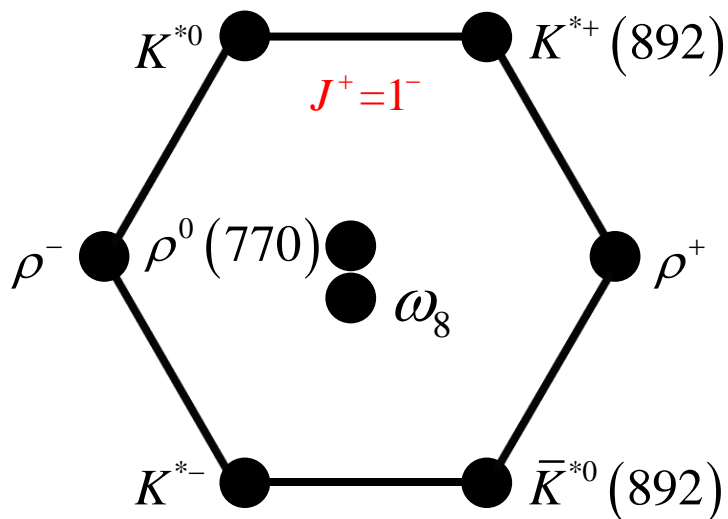

Chiral Partner

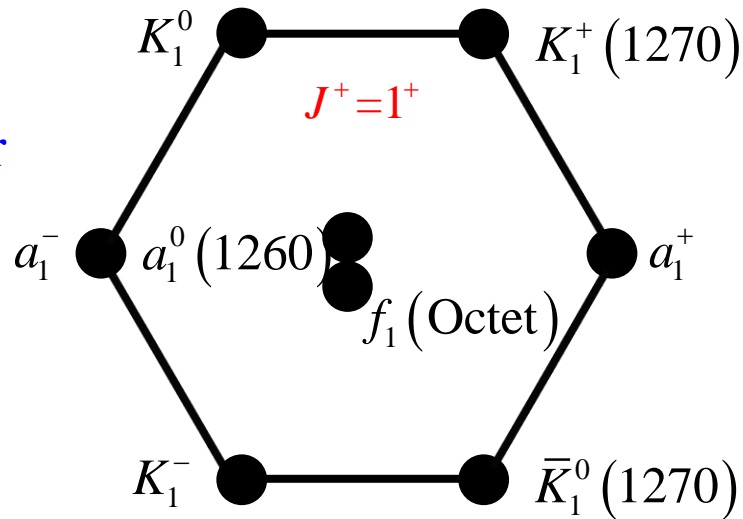

Spin-1 Flavor Singlet



No Chiral Partner

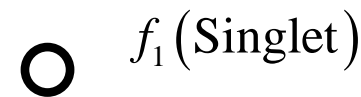

$$\phi(1020) = \bar{s}s$$

$$\omega(782) = \frac{1}{\sqrt{2}}(\bar{u}u + \bar{d}d)$$

$$m_s \gg m_d \sim m_u$$

$$\omega_1 = \frac{1}{\sqrt{3}}(\bar{u}u + \bar{d}d + \bar{s}s)$$

$$\omega_8 = \frac{1}{\sqrt{6}}(\bar{u}u + \bar{d}d - 2\bar{s}s)$$

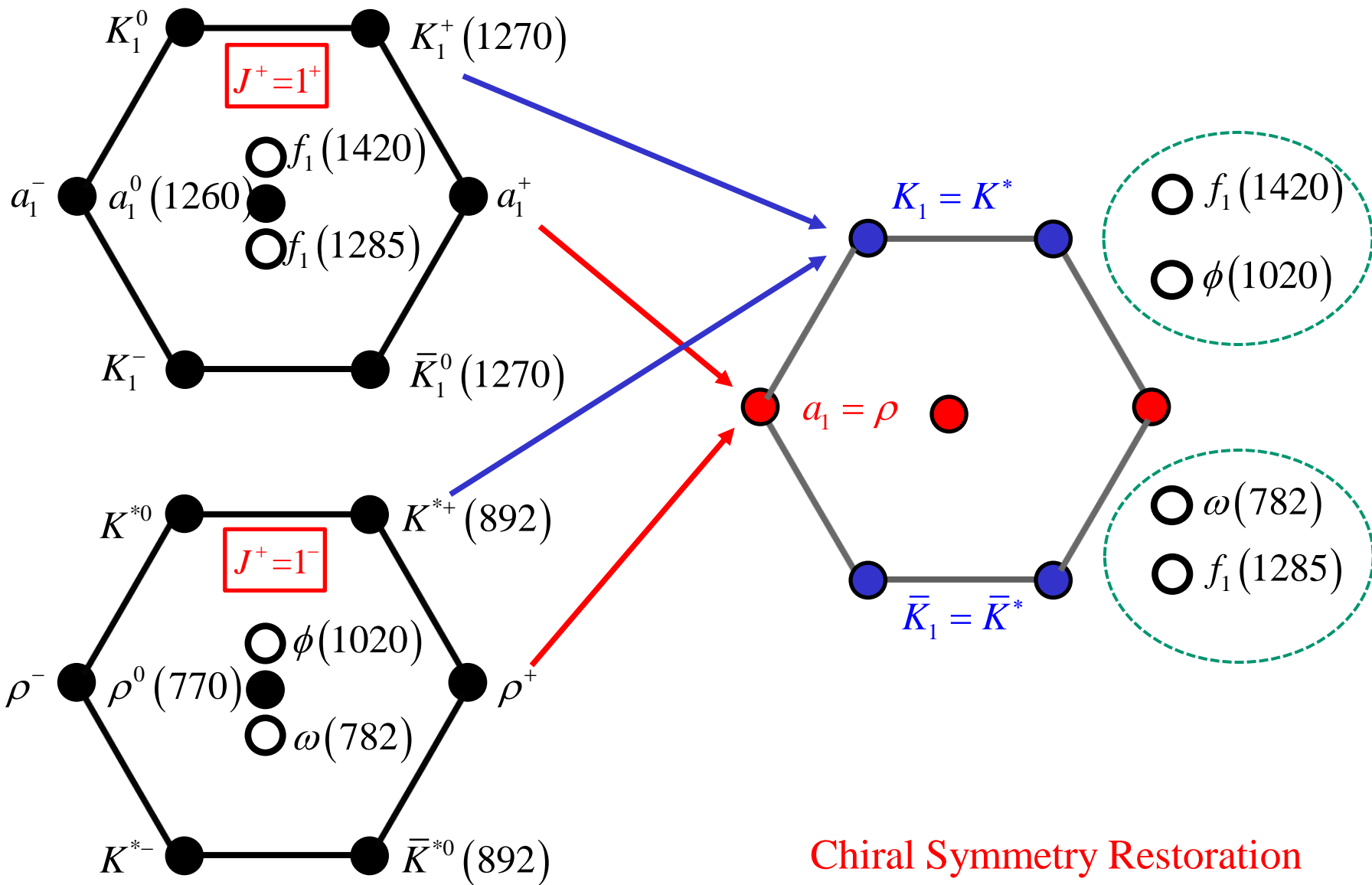

Broken Chiral Symmetry

Which vector meson should one study in medium

1) Hadrons with small width: ϕ is the best candidate

J-PARC E16, E88

| $J^{PC}=1^{--}$ | Mass | Width | $J^{PC}=1^{++}$ | Mass | Width |
|-----------------|---------|---------|-----------------|------|---------|
| ρ | 770 MeV | 150 MeV | a_1 | 1260 | 250–600 |
| ω | 782 | 8.49 | f_1 | 1285 | 24.2 |
| ϕ | 1020 | 4.266 | f_1 | 1420 | 54.9 |
| $K^*(1^-)$ | 892 | 50.3 | $K_1(1^+)$ | 1270 | 90 |

2) Chiral partner: K^* and K_1 is the best candidate

- Decay mode of chiral partners typically has one more pion

$$m_{K^*} - m_{K_1} \propto \langle \bar{q}q \rangle$$

$$K^* \rightarrow K\pi, \quad K_1^- \rightarrow \begin{cases} \rho(\pi\pi) + K \\ \pi + K^*(K\pi) \end{cases}$$

3) If possible measurement of $f_1(1420)$ is also interesting (parity partner of ϕ)

$$m_\phi - m_{f_1(1420)} \propto \langle \bar{s}s \rangle + \text{other}$$

$$\phi \rightarrow K + K \quad f_1(1420) \rightarrow K + K^*(K\pi)$$

Which vector meson should one study in medium

1) Hadrons with small width

J-PARC E16, E88

| $J^{PC}=1^{--}$ | Mass | Width | $J^{PC}=1^{++}$ | Mass | Width |
|-----------------|---------|---------|-----------------|------|---------|
| ρ | 770 MeV | 150 MeV | a_1 | 1260 | 250–600 |
| ω | 782 | 8.49 | f_1 | 1285 | 24.2 |
| ϕ | 1020 | 4.266 | f_1 | 1420 | 54.9 |
| $K^*(1^-)$ | 892 | 50.3 | $K_1(1^+)$ | 1270 | 90 |

2) Use condensate based Operator Product Expansion (OPE) methods

- Can identify Chiral symmetry breaking effects

$$\langle \bar{q}q \rangle$$

$$q \rightarrow \exp(i\gamma_5 \vec{\alpha}) q$$

$$\Pi^{K^*K^*} - \Pi^{K_1K_1} = \frac{1}{V} \int d^4x e^{iqx} \left[\langle \bar{s}\gamma^\mu q(x), \bar{q}\gamma^\mu s(0) \rangle - \langle \bar{s}i\gamma^5\gamma^\mu q(x), \bar{q}i\gamma^5\gamma^\mu s(0) \rangle \right] = \frac{c_4}{q^4} \langle m_s \bar{q}q \rangle + \frac{c_6}{q^6} \langle \bar{s}s \bar{q}q \rangle \dots$$

- Can relate them to mass

$$\Pi(q^2) = \frac{1}{\pi} \int ds \frac{\text{Im}\Pi(s)}{s - q^2}$$

$K1/K^*$ production in heavy ion collision

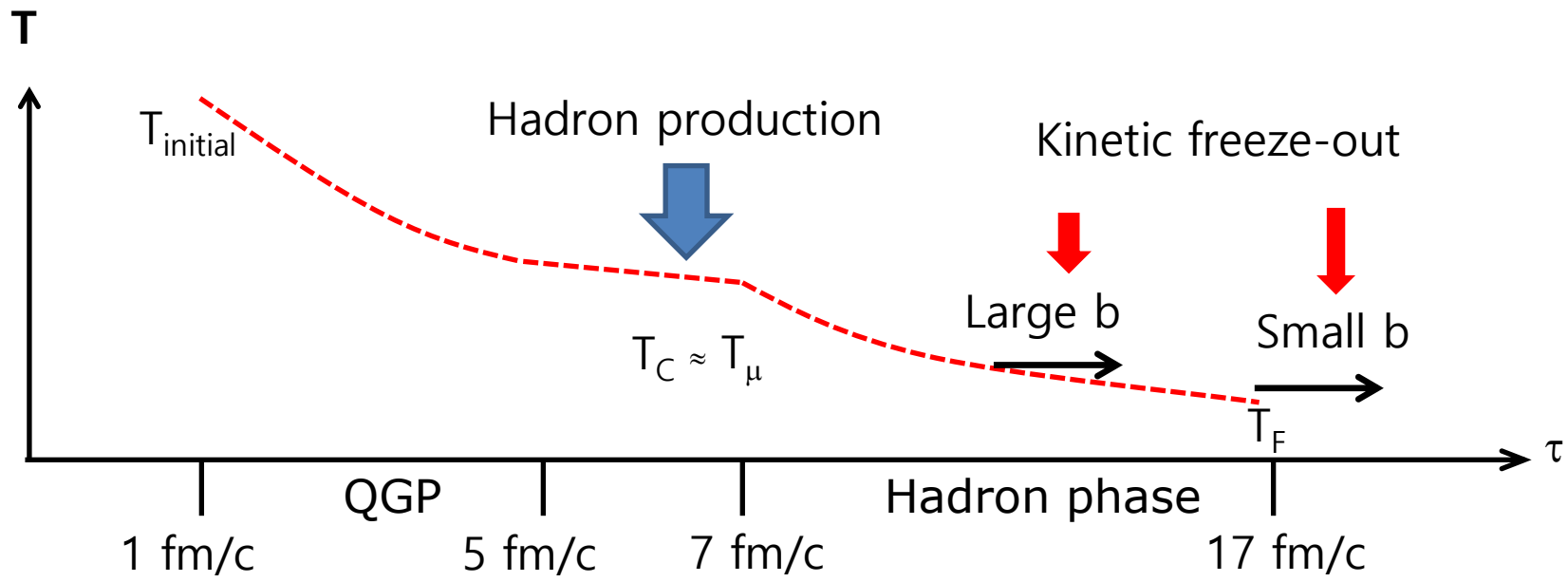
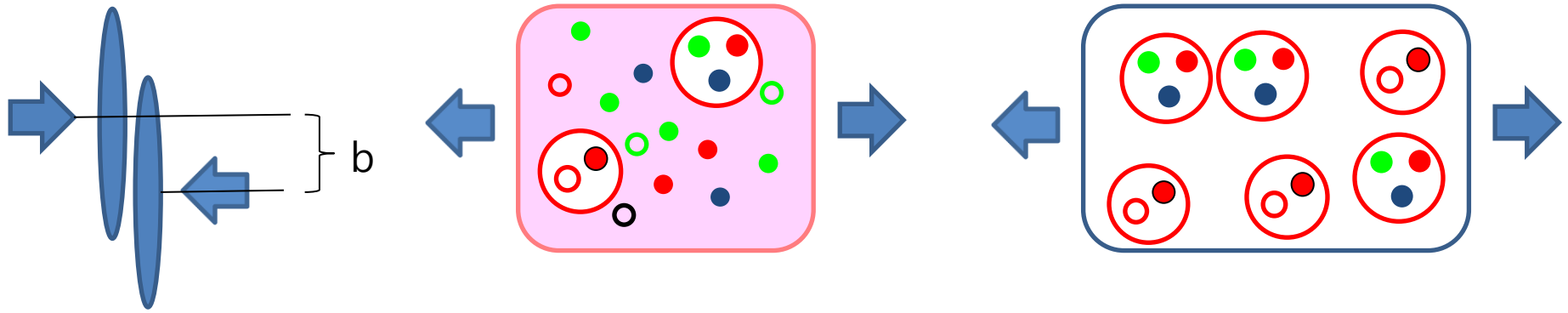

5) K_1/K^* vs Centrality

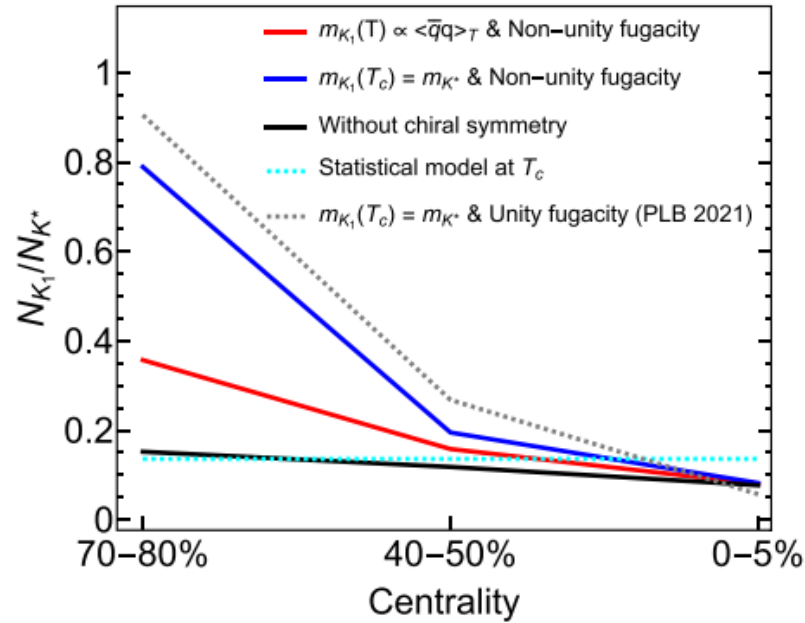

FIG. 5. The yield ratio K_1/K^* in Pb+Pb collisions at $\sqrt{s_{NN}} = 5.02$ TeV at three centralities of 0–5%, 40–50%, and 70–80% for various scenarios.

5) K1/K* vs Centrality



Study of K_1 meson production in pp collisions with ALICE

SU-JEONG JI⁽¹⁾ ON BEHALF OF THE ALICE COLLABORATION | ¹⁾ PUSAN NATIONAL UNIVERSITY



SIGNAL EXTRACTION

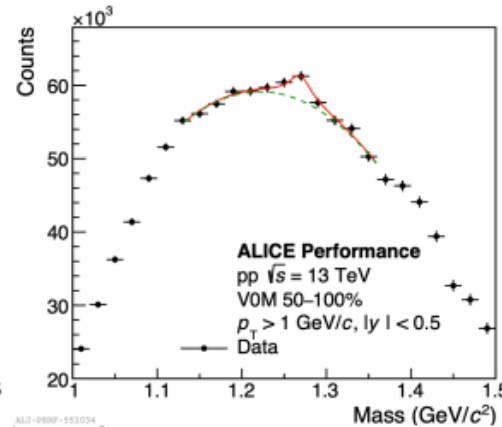
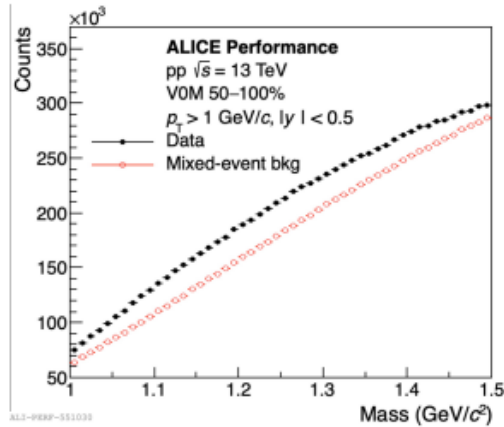

Signal: $\pi^\pm \pi^\mp K^\pm$ pairs

Background:

$$\pi^\pm \pi^\pm K^\mp, \pi^\pm \pi^\pm K^\pm$$

pairs from mixed event

(30 events, $\Delta z_{vtx} \leq 2$ cm)

Fit Function: Breit-Wigner
+ quadratic fn.

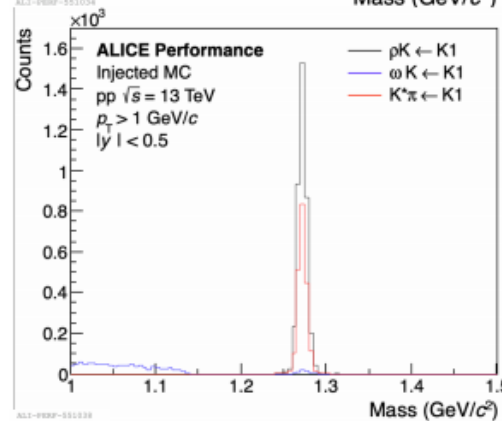

The signal peak is seen at 1270 MeV/c² in data.

6) K1/K* at JPARC

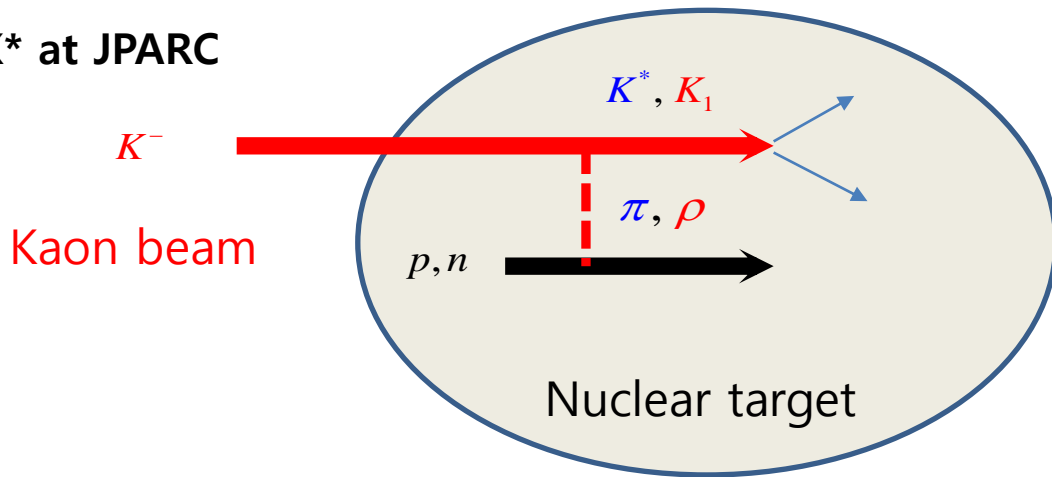

$$K_1^- \rightarrow \begin{pmatrix} \rho^0 K^- \\ \rho^- \bar{K}^0 \end{pmatrix} \quad \begin{pmatrix} \pi^0 K^{*-} \\ \pi^- \bar{K}^{*0} \end{pmatrix}$$

$$\bar{K}_1^0 \rightarrow \begin{pmatrix} \rho^+ K^- \\ \rho^0 \bar{K}^0 \end{pmatrix} \quad \begin{pmatrix} \pi^+ K^{*-} \\ \pi^0 \bar{K}^{*0} \end{pmatrix}$$

Obtained angular distributions for K* and K₁ meson decays

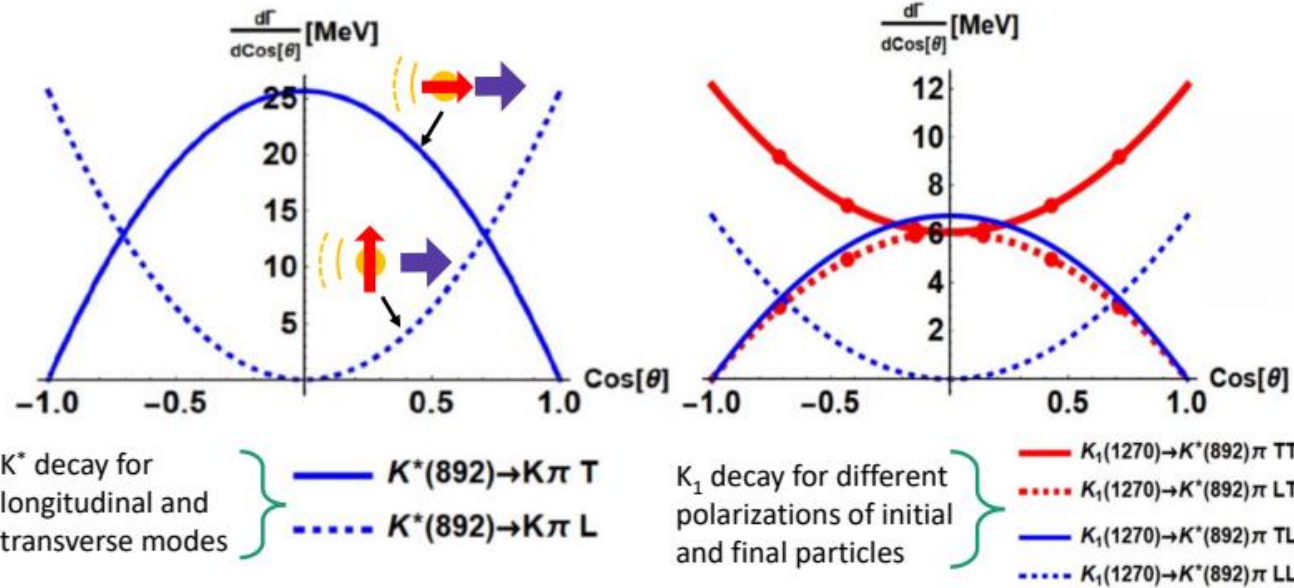

I.W. Park, H. Sako, K. Aoki, P. Gubler and S.H. Lee, arXiv:2403.18288 [hep-ph].



Second collaborative work by theorists and experimentalists as a result of the REIMEI project!

- Possible future experiment to measure masses of chiral partners

→ K_1 excitation energy measurement at JPARC

Decay mode of K_1 ($\Gamma=90\text{MeV}$)

| Decay mode | Fraction |
|---------------------------------|----------|
| $K_1(1270) \rightarrow K \rho$ | 42 % |
| $K_1(1270) \rightarrow K^* \pi$ | 16 % |

