



Design of the Readout Electronics for Scintillator-Based Multi-Neutron Detector Array

25th IEEE Real Time, 2026

--Chengjun Zhang #55

➤ Scintillator-Based Multi-neutron Detector Array

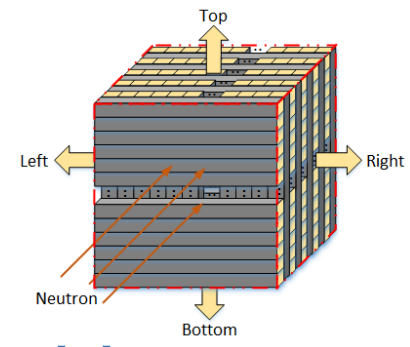

➤ FEM (front-end readout electronics module)

- SiPM integration & signal transmission
- SiPM signal matching

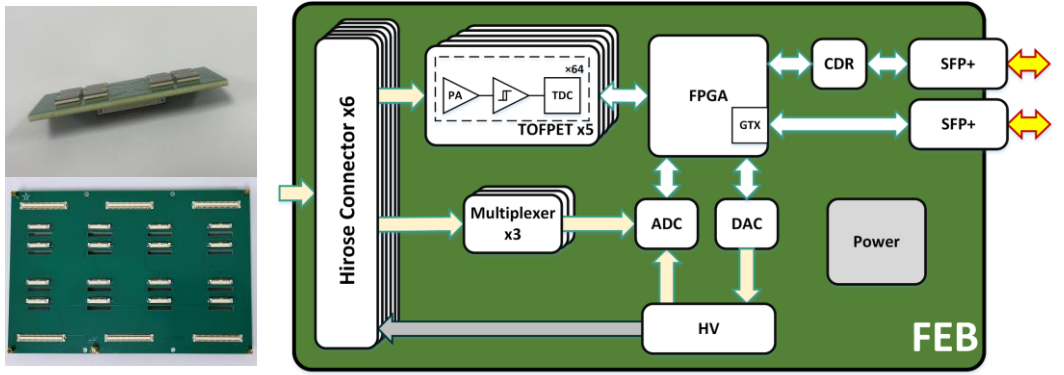
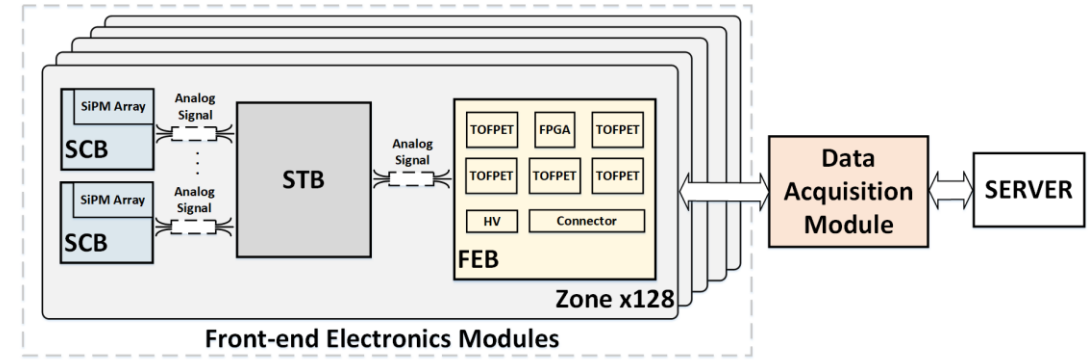

➤ DAM (Data acquisition module):

- Trigger selection scheme: Two-dimensional annular timing map based on image convolution principle

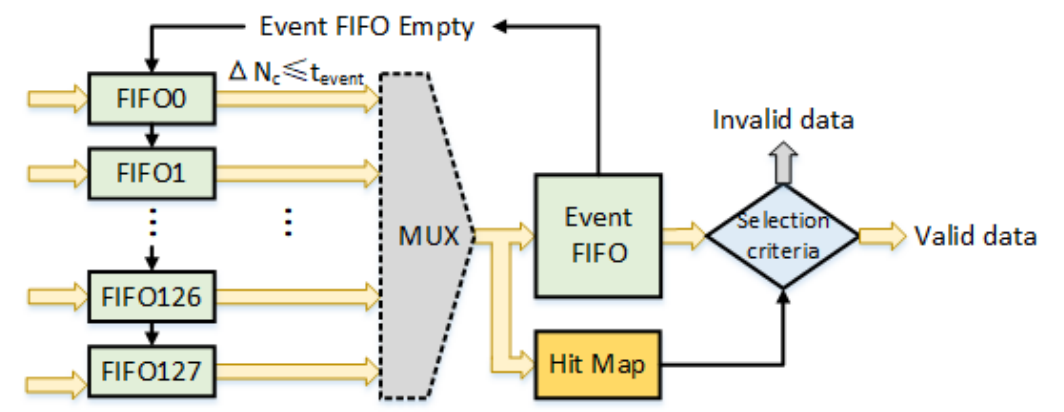
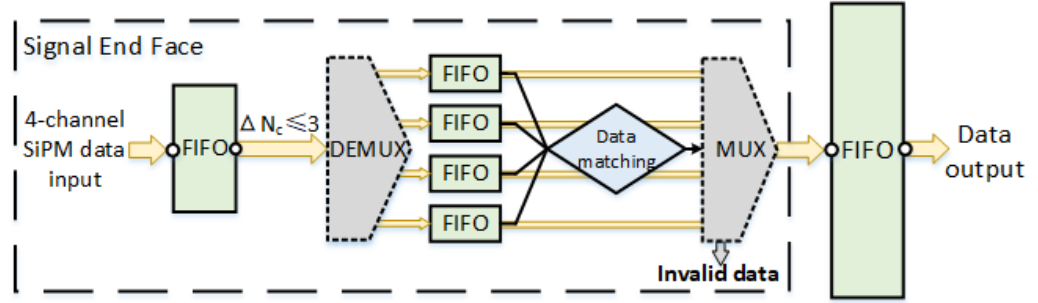



Design of the Readout Electronics for Scintillator-Based Multi-Neutron Detector Array

25th IEEE Real Time, 2026

--Chengjun Zhang #55

➤ Experimental Setup

- Small-scale plastic scintillator array
- Four parallel detector units
- 4 SCBs, 2 pSTBs, 2 FEBs, 1 DAM

➤ Test Result

- Good time resolution: better than 110ps
- Good position resolution: 1.2cm
- Fulfilling the readout electronics requirements

