



Electronics for Two-Dimensional Magnetic-Field Measurement in a Polarized-Light Helium Optically Pumped Magnetometer

25th IEEE Real Time, 2026 --Xuan Wang

- Field direction from amplitudes of transmitted harmonics

$$R_{DC/2\omega} = \frac{3 \cos^2 \varphi - 1}{\sin^2 \varphi}$$

$$R_{2\omega/\omega} = \frac{\Omega}{2} \tan \varphi$$

$$\Omega \propto \sqrt{\cos^2 \varphi + \sin^2 \alpha \cdot \sin^2 \varphi}$$

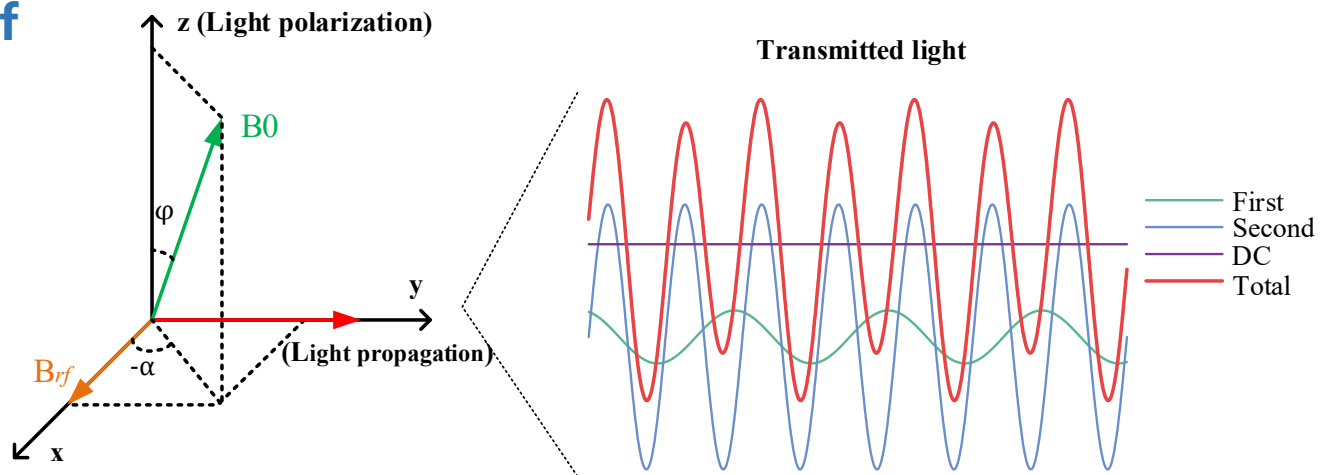

- Compact electronics board
 - DDS-based RF field generation
 - ADC acquisition and digitization
 - Real-time data processing

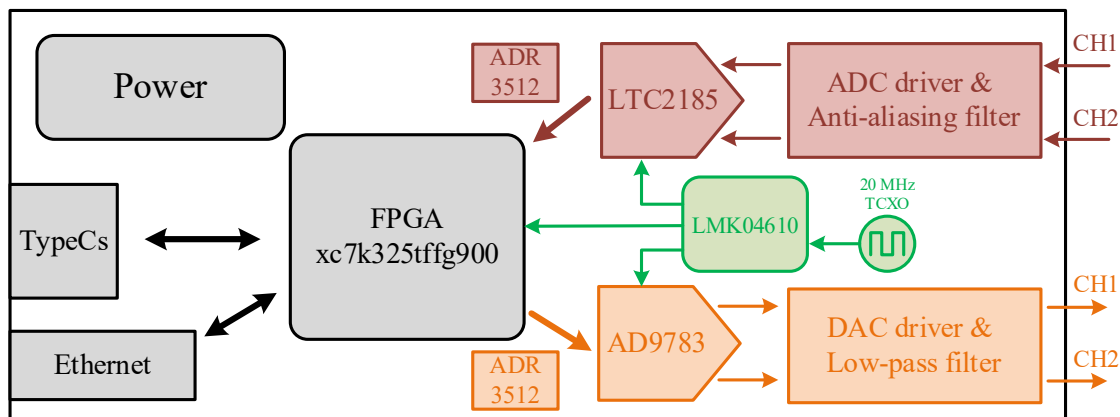

- FPGA Logic
 - Phase-coherent DDSs
 - Digital LIA
 - Control module

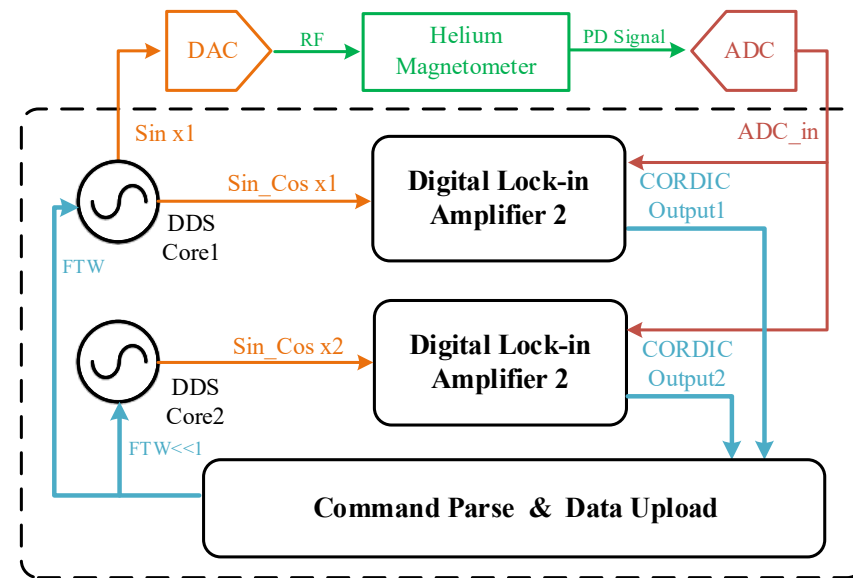



Electronics for Two-Dimensional Magnetic-Field Measurement in a Polarized-Light Helium Optically Pumped Magnetometer

25th IEEE Real Time, 2026 --Xuan Wang

➤ Experimental Setup

- Magnetically shielded environment
- High-stability laser
- Low-noise current source
- Ethernet communication

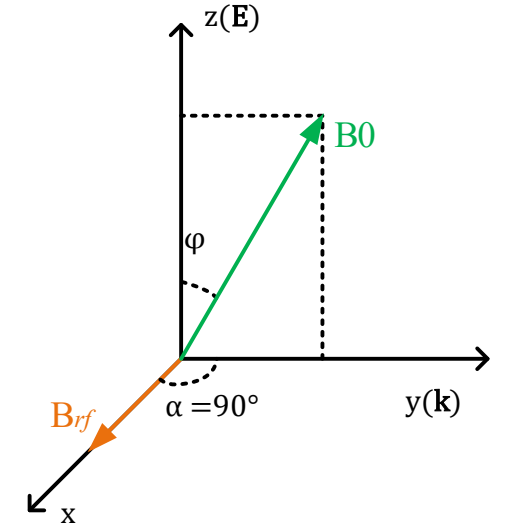
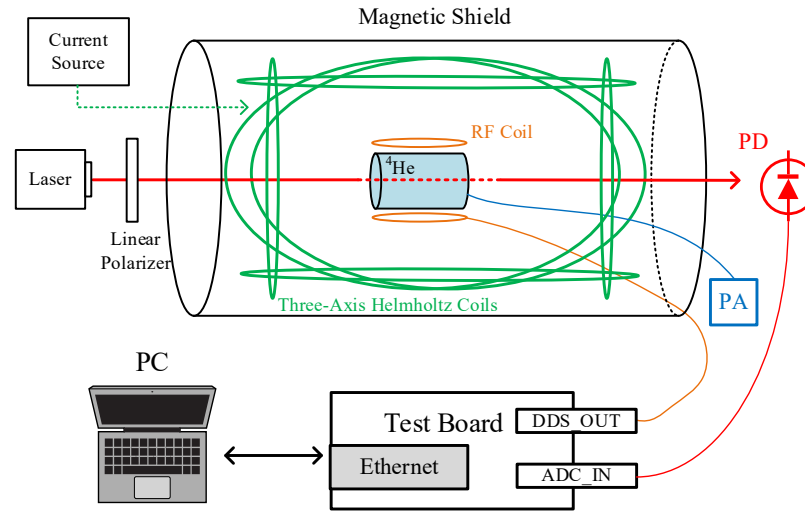

➤ Measurement Results

- Harmonic measurements agree with expectations
- High bandwidth --1 kHz
- High accuracy in 2D field sensing; error $\approx 0.005^\circ$ near 90°

