

# Electronics for Two-Dimensional Magnetic-Field Measurement in a Polarized-Light Helium Optically Pumped Magnetometer



Xuan Wang<sup>1</sup>, Yu Wang<sup>1</sup>, Jiajun Yuan<sup>1</sup>, Changqing Feng<sup>1</sup>

## Introduction

- The helium optically pumped magnetometer (He-OPM) is a room-temperature, high-sensitivity magnetic-field sensor with broad application.
- With linearly polarized optical pumping, a single laser beam inherently carries magnetic-field direction information. Different field directions produce distinct harmonic components in the transmitted signal.
- This work develops dedicated electronics for linearly polarized He-OPMs to accurately measure these harmonic components and extract magnetic-field information.
- A compact electronics board was designed. Experimental results demonstrate good performance in two-dimensional magnetic-field direction measurements.

## Scheme

### Principle

The He-OPM operates based on optical pumping and magnetic resonance. Under linearly polarized light, the transmitted signal contains DC, fundamental, and second harmonic components. According to the theory, the amplitude ratios  $R_{DC/2\omega}$  and  $R_{2\omega/\omega}$  depend on the field direction. Assuming the orientation angles are defined as shown in the figure, these ratios can be expressed as follows:

$$R_{DC/2\omega} = \frac{3 \cos^2 \varphi - 1}{\sin^2 \varphi}$$

$$R_{2\omega/\omega} = \frac{\Omega}{2} \tan \varphi$$

where  $\Omega$  is the Rabi frequency

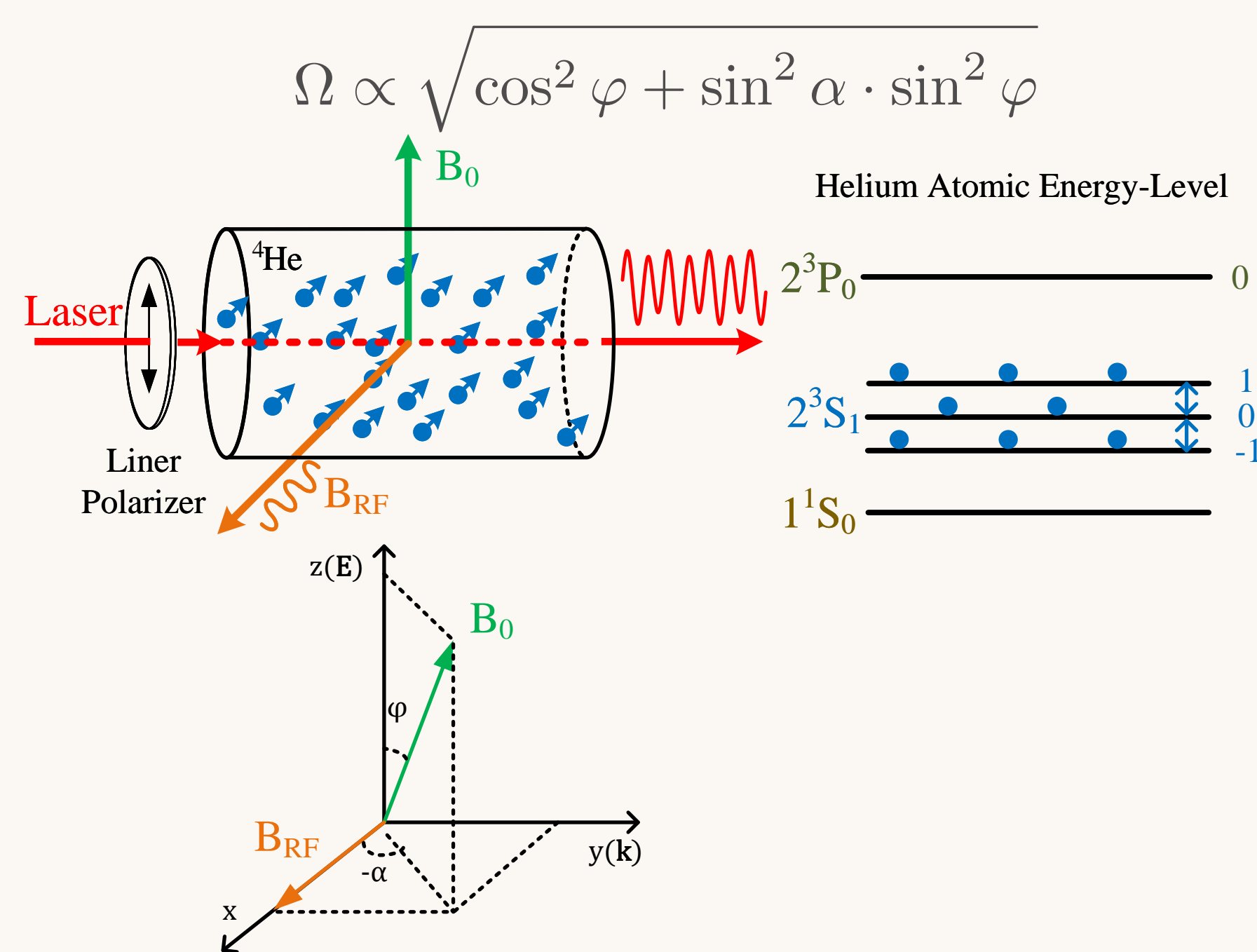

### Board Design

- RF magnetic field generation based on DDS to drive magnetic resonance.
- Acquisition of the PD signal with digitization by a high-speed ADC.
- Low-noise, low-drift analog front-end circuits and a low-phase-noise clock source are employed to minimize electronic noise.
- Real-time data processing in the FPGA to extract magnetic field information.

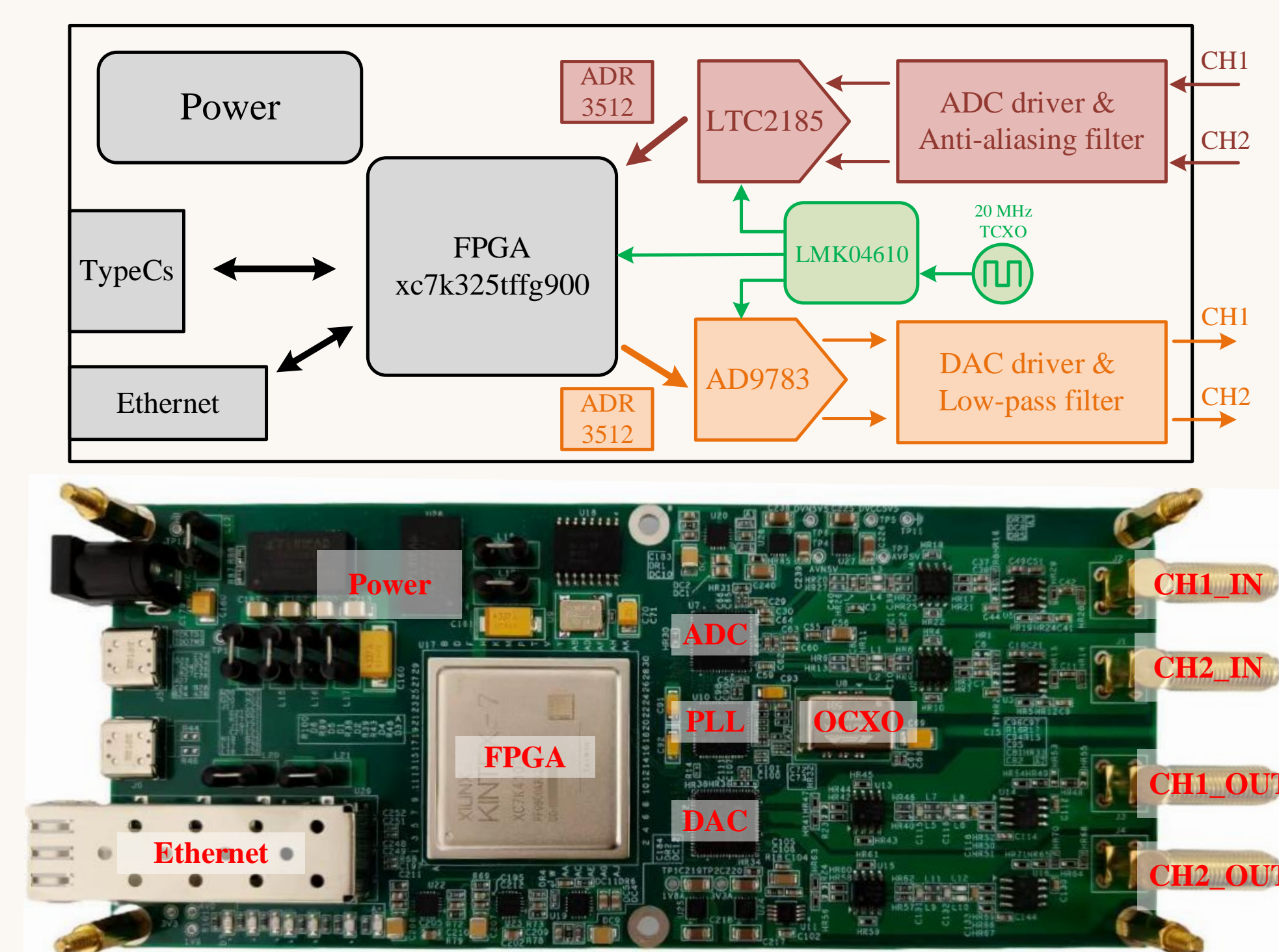

### FPGA Logic

- Two DDS modules with a frequency ratio of 2 generate phase-coherent reference signals, and the fundamental sine is output to the DAC.
- The digital lock-in amplifier consists of mixers, low-pass filters, and a phase-amplitude extraction module based on the CORDIC algorithm.
- The low-pass filtering stage consists of a CIC filter for decimation followed by a fourth-order RC-type IIR filter.

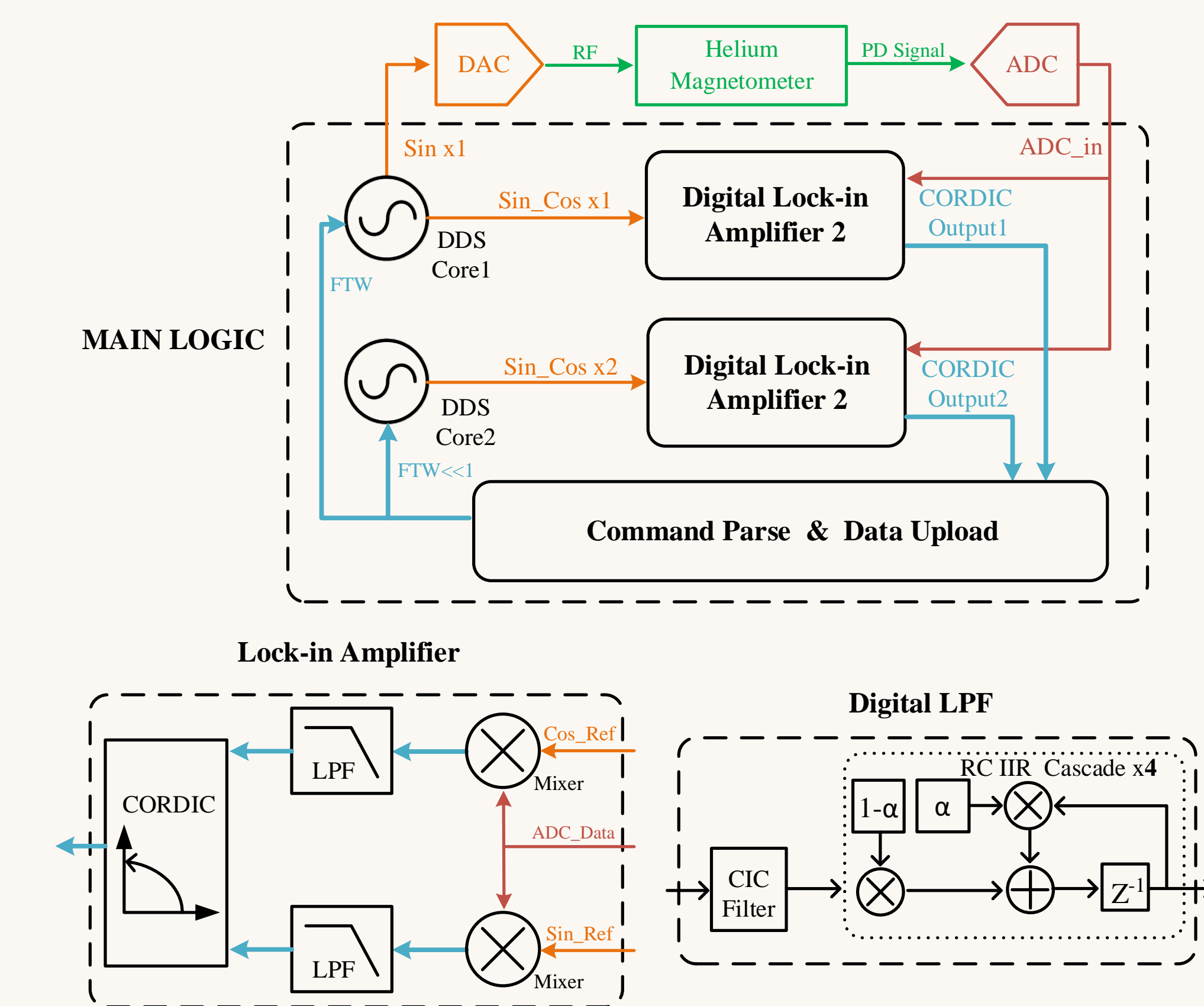

## Test and Result

### Experimental Setup

- Magnetically shielded environment with field generated by three-axis Helmholtz coils.
- High-stability laser and low-noise current source.
- PD and electronics board placed outside the shield.
- Data transmitted to PC via Gigabit Ethernet.

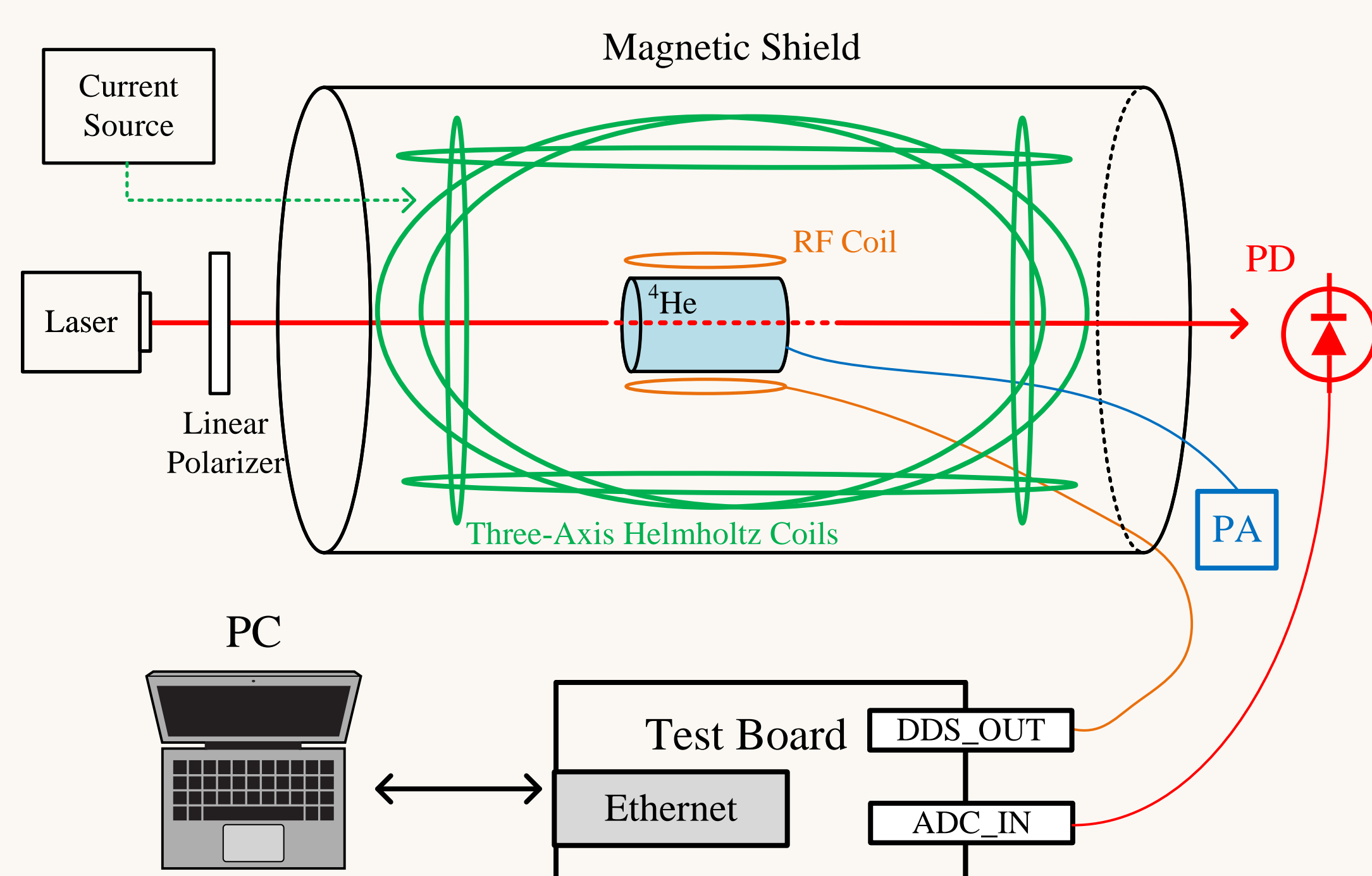

### Measurement Results

During the measurement,  $\alpha$  was fixed at  $90^\circ$ , with  $\varphi$  as the variable angle. The DC, fundamental, and second harmonic amplitudes were measured for known  $\varphi$  values. The measured results agree well with the theoretical predictions.

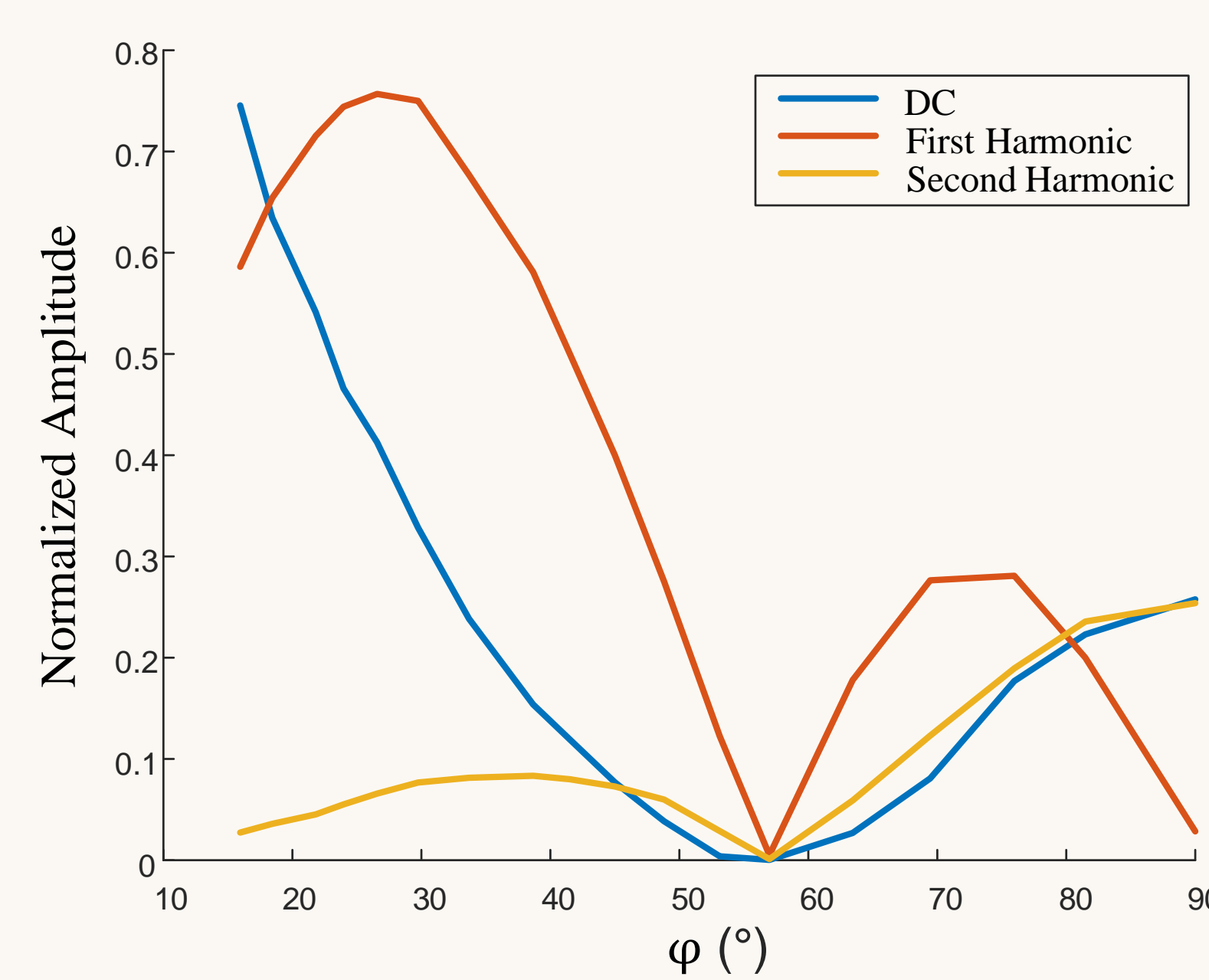

In this case,  $\Omega$  remains constant. This constant was determined by performing a linear fit of  $R_{2\omega/\omega}$  versus  $\tan \varphi$  for known  $\varphi$  values. The results exhibit good linearity. Subsequently,  $\varphi$  can be determined directly from measurements of  $R_{2\omega/\omega}$ .

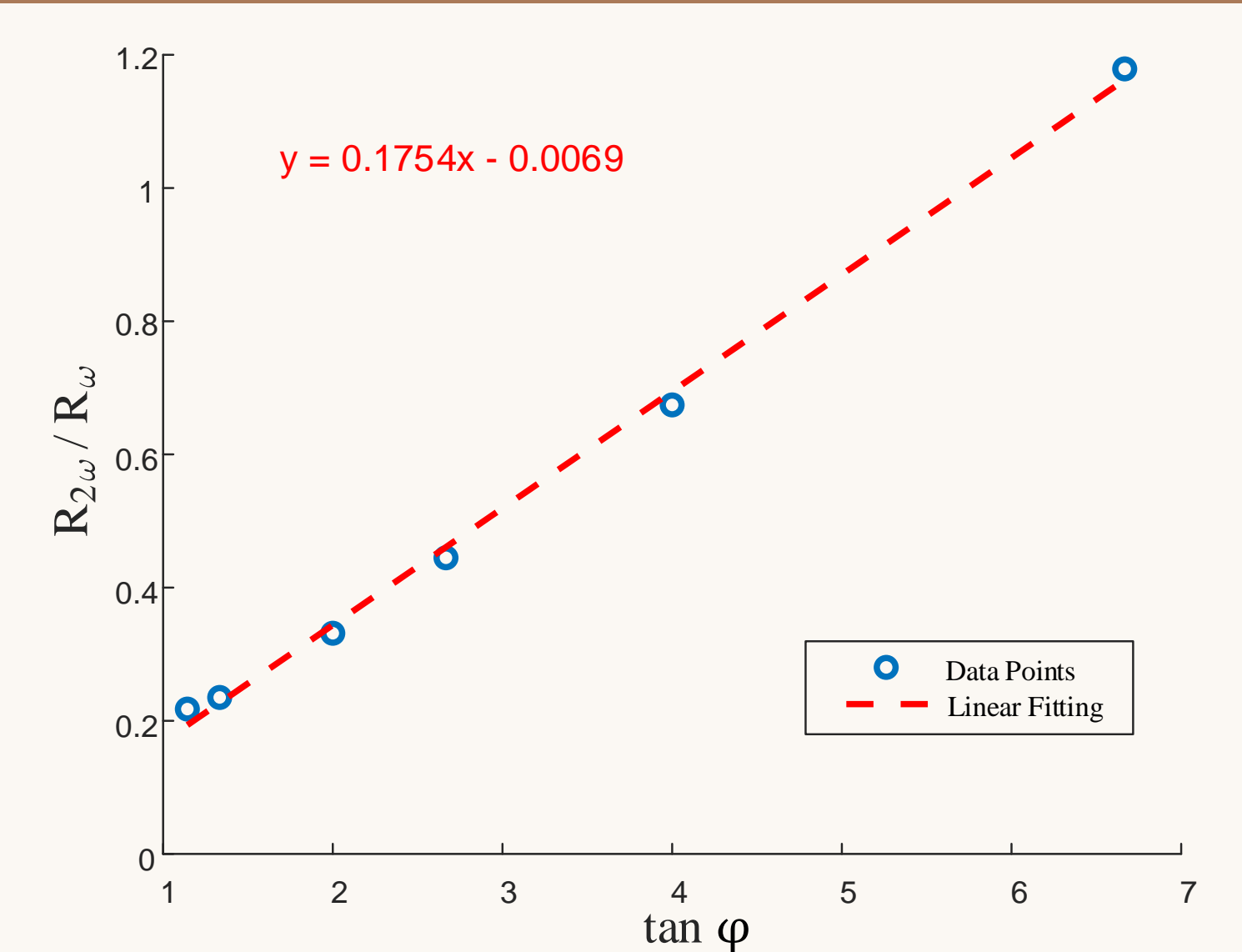

The measurement error of  $\varphi$  varies with angle and increases in certain regions where the harmonic amplitudes are relatively small. Around  $90^\circ$ , the measurement error is approximately  $0.005^\circ$ .

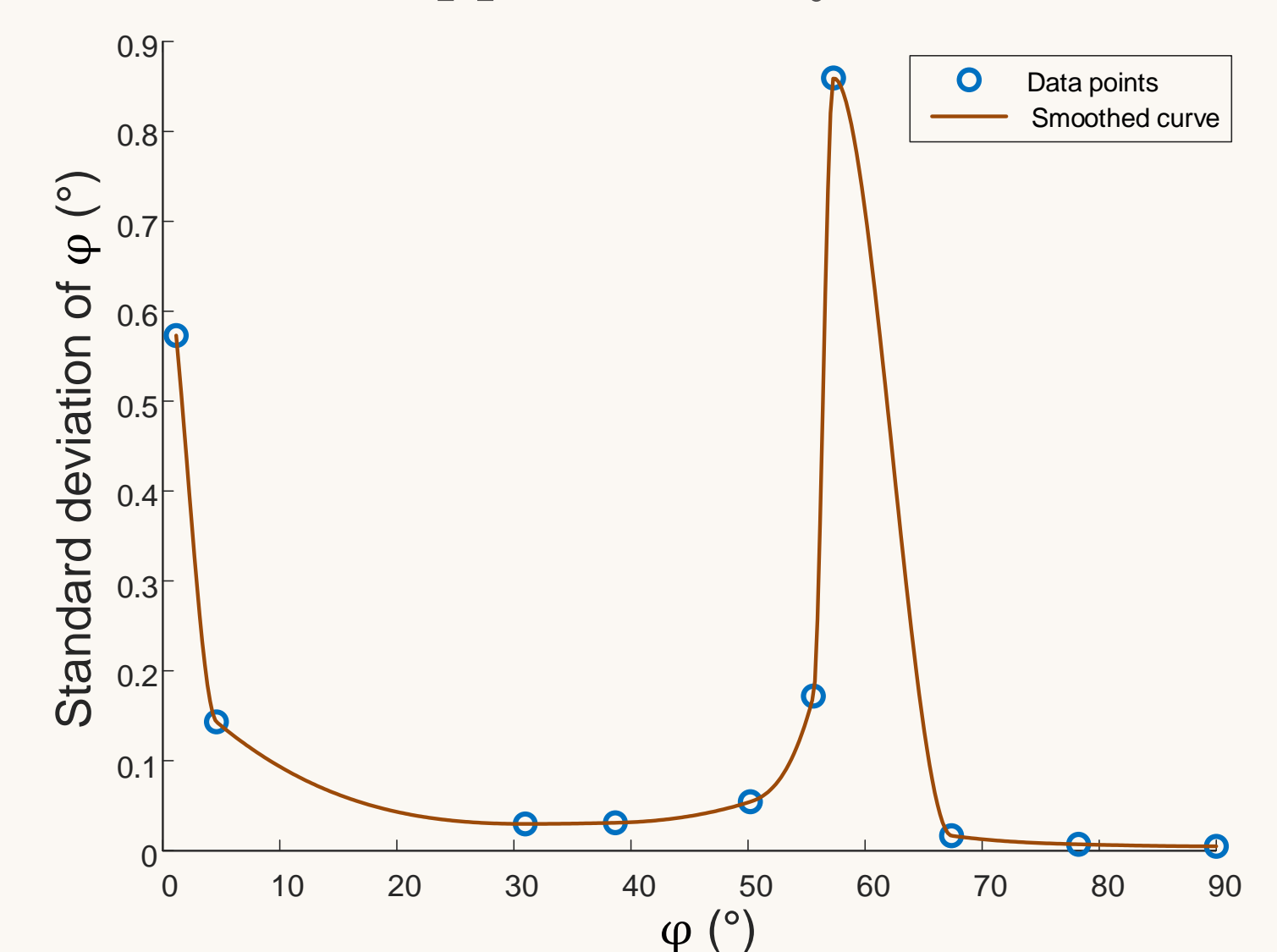

## Conclusion

- The electronics board operates as intended, and the FPGA logic performs as designed. The system is capable of accurately measuring the direction of a two-dimensional magnetic field.
- Currently, only the first and second harmonics are utilized. Future work will focus on suppressing DC drift—mainly caused by laser instability and low-frequency noise—and achieving accurate DC measurement, enabling full three-dimensional magnetic field sensing.