

TRIGGER AND DAQ SYSTEM FOR THE MUEDM EXPERIMENT

Carlo Veo^{a,b}, on behalf of the muEDM collaboration

^aUniversità di Pisa, ^bINFN Sezione di Pisa

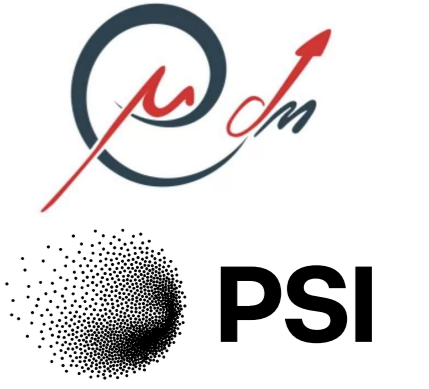

The **muEDM experiment** aims to measure the **muon electric dipole moment** (EDM) with a sensitivity of $\sigma d \leq 6 \times 10^{-23} e \cdot \text{cm}$. It will employ one of the high-intensity **muon beam** at the Paul Scherrer Institute (PSI) in Switzerland, exploiting for the first time two key techniques to test the existence of the muon EDM: a fast magnetic pulse generated by the **kicker coils** to stop and store muons in a storage orbit of 30 mm radius, and the **frozen-spin method** using two cylindrical electrodes to maintain the muon spin direction fixed with respect to its momentum. By measuring the **asymmetry in the emission** of decay positrons along and opposite to the magnetic field of the main solenoid, the experiment can directly probe the presence of a muon EDM.

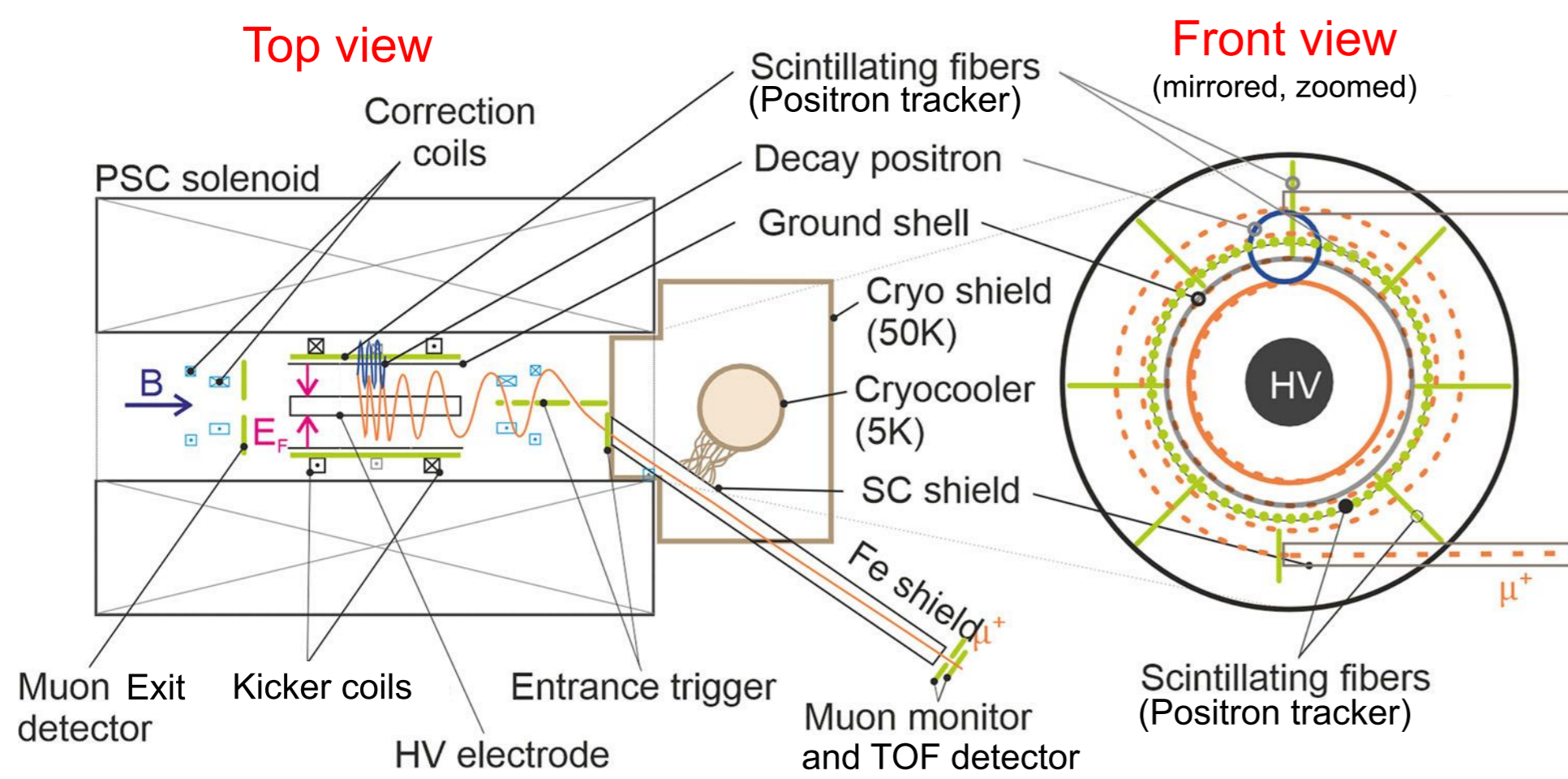

Requirements for the TDAQ

Trigger:

- Generate a fast and low jitter (< 5 ns) signal to start the data acquisition (DAQ) and energize the kicker coils;
- Select muons suitable for storage ($\sim 4 \times 10^{-3}$ of total muons) and veto the others.

For the DAQ:

- Acquisition window larger than 10 μs to records pre-trigger hits and muon decays;
- Multi-hit capability on each channel;
- $\lesssim 1$ ns intrinsic time resolution;
- Channel-to-channel synchronization < 100 ps;
- 1500 channels or more.

The Trigger Detector

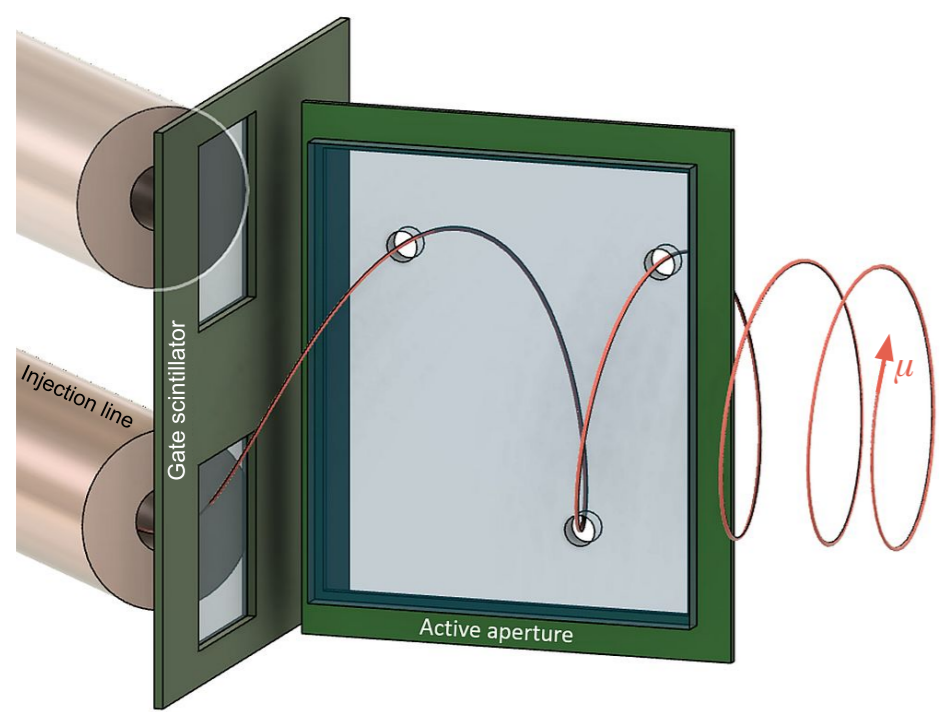

- **Gate detector:** $35 \times 35 \text{ mm}^2$ scintillator tile with a thickness of $50 \mu\text{m}$ read out by four SiPMs.
- **Aperture detector:** 5 mm-thick scintillator tile read out by eight SiPMs connected in parallel. The tile includes six apertures, three for each muon injection line, positioned around the expected muon trajectories.

The **trigger logic** is defined by the **gate** in **anti-coincidence** with the **aperture**.

- A global **busy signal** prevents generation of trigger signals during DAQ operations or kicker downtime (~ 1 ms).

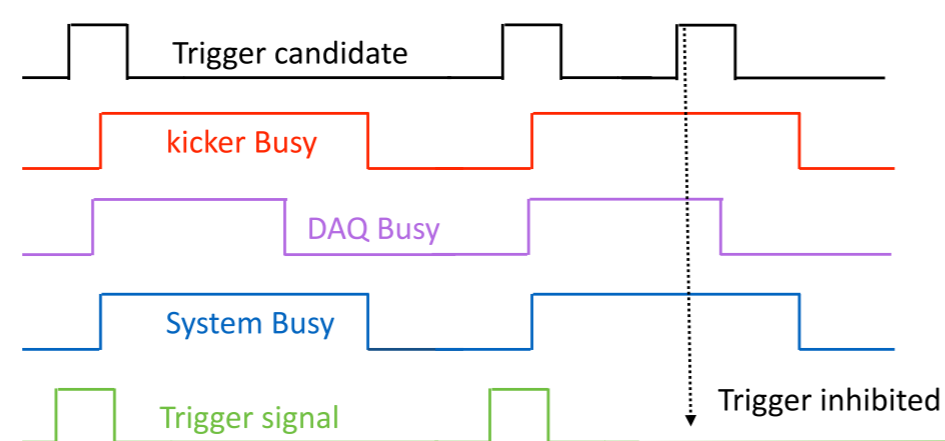

Test Beam in 2025

- 6 FERS + Concentrator (25 FERS in final configuration);
- Trigger received via LEMO cables used to open a $20 \mu\text{s}$ gate;
- For each hit time-of-arrival (ToA) and time-over-threshold (ToT) are saved;
- Single channel hit rate for slow control purpose.

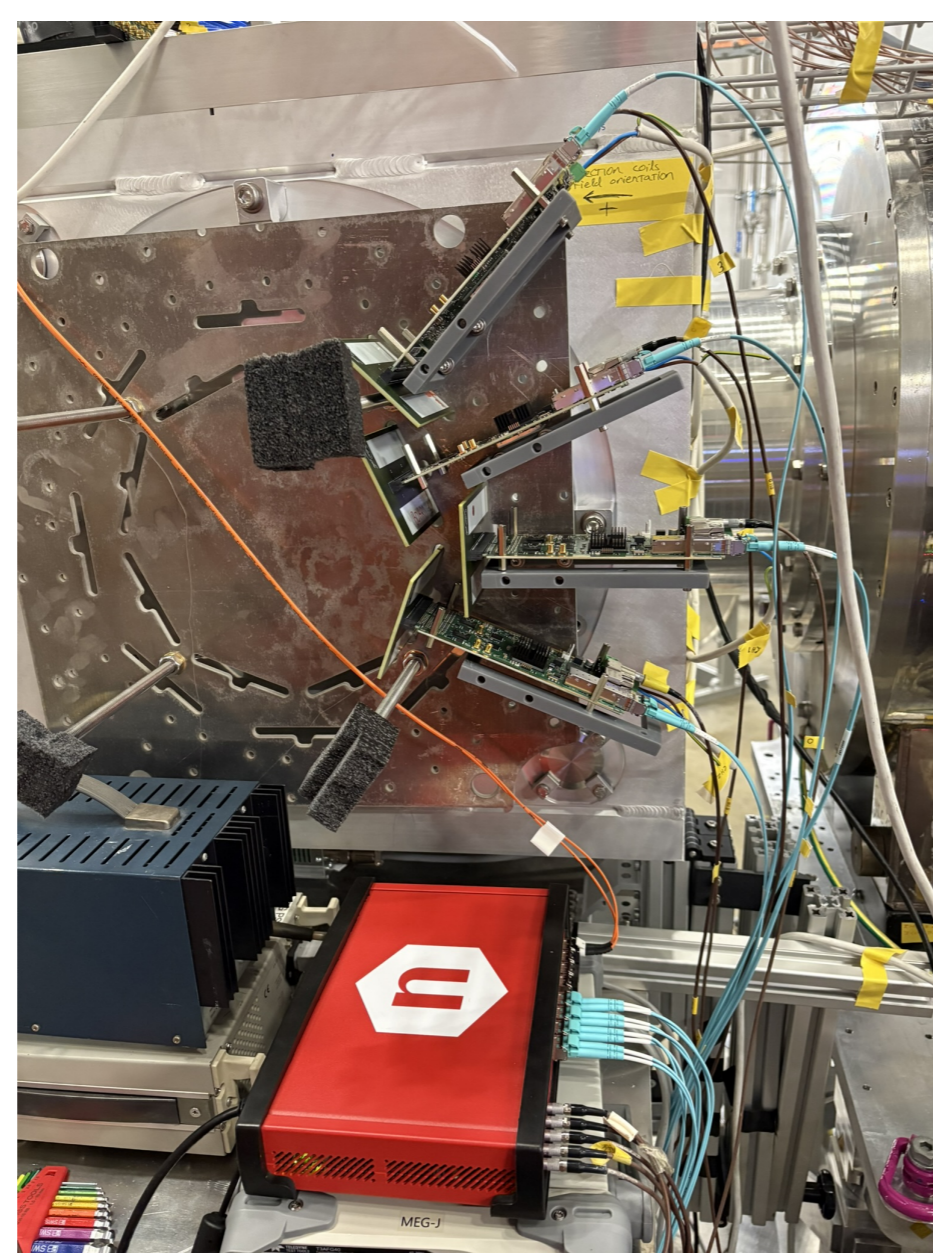
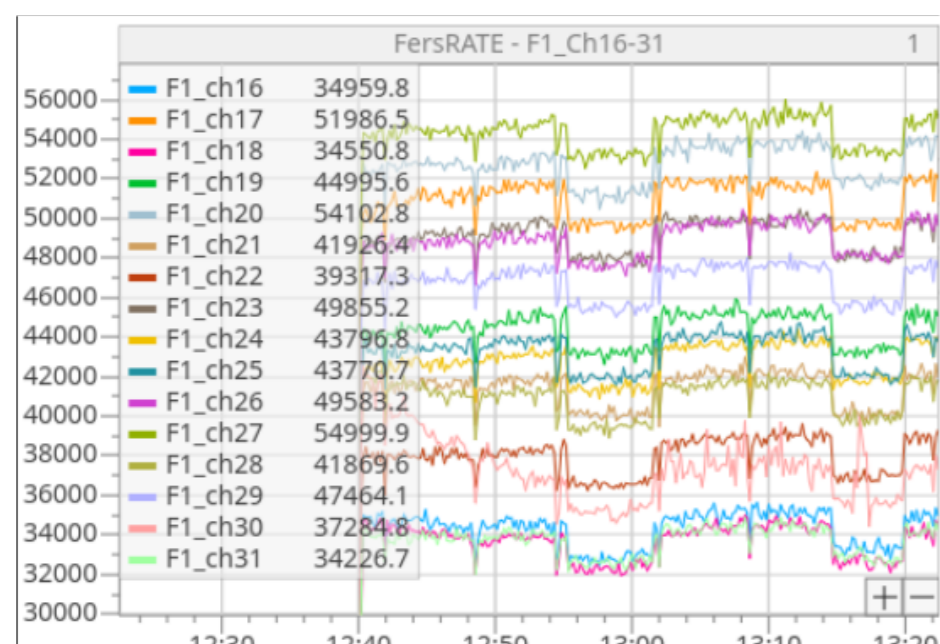
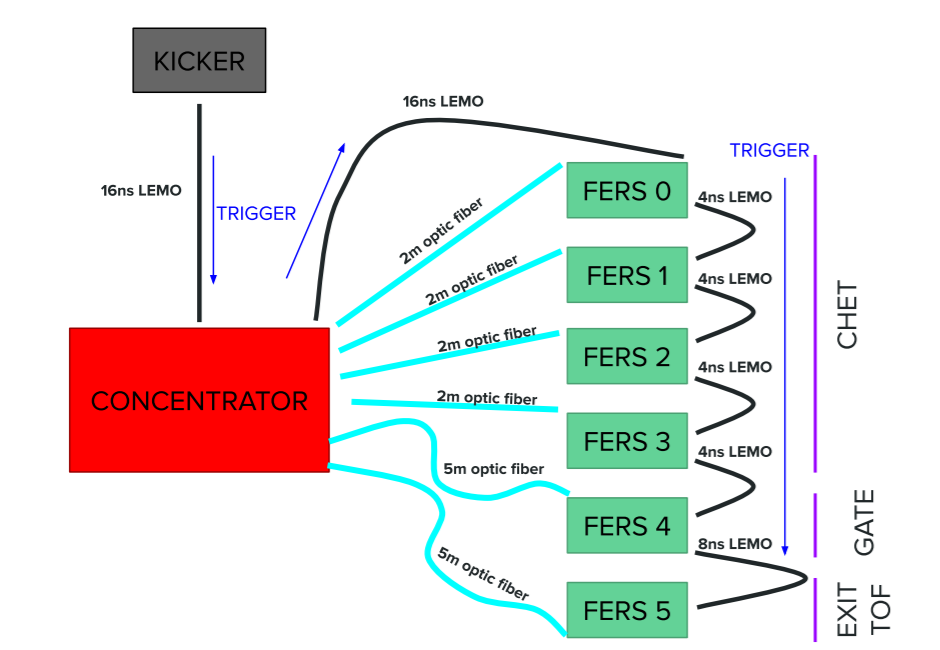

DAQ Hardware: CAEN FERS-5200



FERS-A5202

- 64 input channels;
- Internal SiPM biasing (A7585D PS module), signal preamplification and discriminator (Citiroc-1A chip);
- Charge (QDC) and time (TDC) measurements with multi-hit TDC (0.5 ns time resolution).

FERS-A5203

- CERN picoTDC chip (resolution 3.125 ps);
- Used for time-of-flight measurement.



DT5215 Concentrator board

- Handling of up to 128 FERS boards with TDLINK optic fibers;
- Time synchronization;
- Bridge for commands and data packets between computer and the FERS boards.

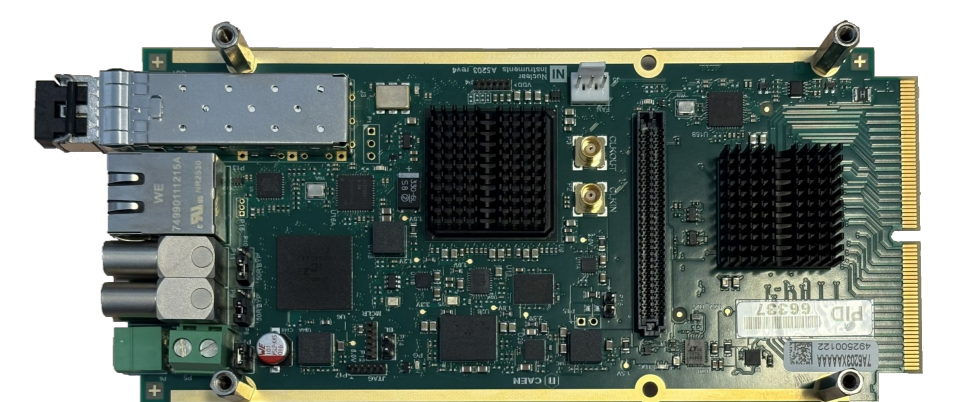

DAQ Software

Development of an independent *C++* library to control and configure multiple FERS boards.

- It relies on CAEN functions which directly communicate to the hardware;
- Boards are configured using an XML file;
- Library implemented initially into a command-line program and subsequently into a **MIDAS** frontend.

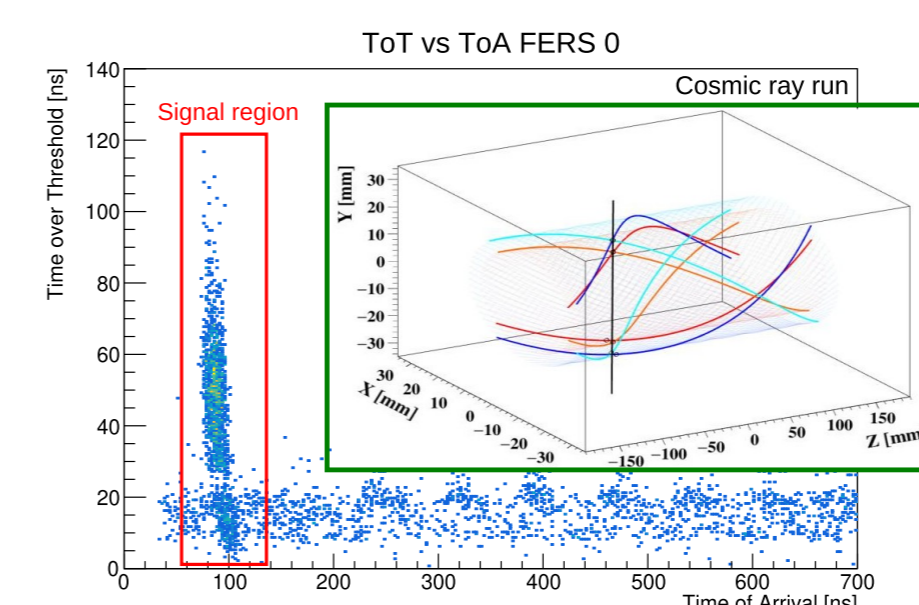

Laboratory tests with MIDAS software, the positron tracker, and cosmic rays.

Online Database Browser	
Equipment / FersDAQ / Settings	
Key	Value
▼ FersDAQ	
Conc0	
FLab0	
FLab1	
ID	1 (0x1)
AcqMode	TIMING
HVVBias	0
MaximumCurrent	1
HVDynamicRange	4.5
HVFine	*
Masks	*
PairCntWindow(ns)	[0] 0xFFFFFFFF (4294967295)
PairCntWindow(ns)	[1] 0xFFFFFFFF (4294967295)
BunchTrgSrc	TLOGIC
ToT	1 (0x1)

