

Distributed Modeling and Simulation Methods for Digital Tokamaks

(25th IEEE Real Time Conference - La Biodola, Elba, Italy)



Guo Heru, Yuan Qiping, Zhou Pengyu, Xiao Bingjia

1 Institute of Energy, Hefei Comprehensive National Science Center, Hefei, China.

2 Institute of Plasma Physics, Hefei Institutes of Physical Science, Chinese Academy of Sciences, Hefei, China.



Abstract Tokamak devices consist of numerous tightly coupled subsystems, making traditional single-model simulations insufficient for future fusion reactors. Accurate dynamic characterization requires collaborative modeling under unified standards. Simulation platforms must support independent subsystem development, seamless system-level integration, and multi-rate asynchronous execution. This paper proposes a distributed collaborative modeling and simulation solution for digital tokamaks based on the Plasma Control Simulation Verification Platform (PCSVP). It provides standardized interfaces for subsystem integration, a multi-rate asynchronous data management mechanism to handle heterogeneous response frequencies, and an asset management toolchain for traceable, reusable, and low-threshold collaborative development. The approach significantly improves integration efficiency and accelerates large-scale model iteration.

Challenges

- Large-scale strongly coupled multi-subsystem tokamak systems
- Heterogeneous frequencies and multi-timescale co-simulation
- Large-scale collaborative model and parameter management

Solutions

- Distributed collaborative simulation method
- Multi-rate asynchronous simulation mechanism
- Distributed model management method

Experimental Validation and Results

Deploy three system models (controller, power supply, and plasma) on different nodes for closed-loop control simulation to test the correctness of the distributed simulation method, and compare the results between the distributed closed-loop simulation and the standalone simulation.

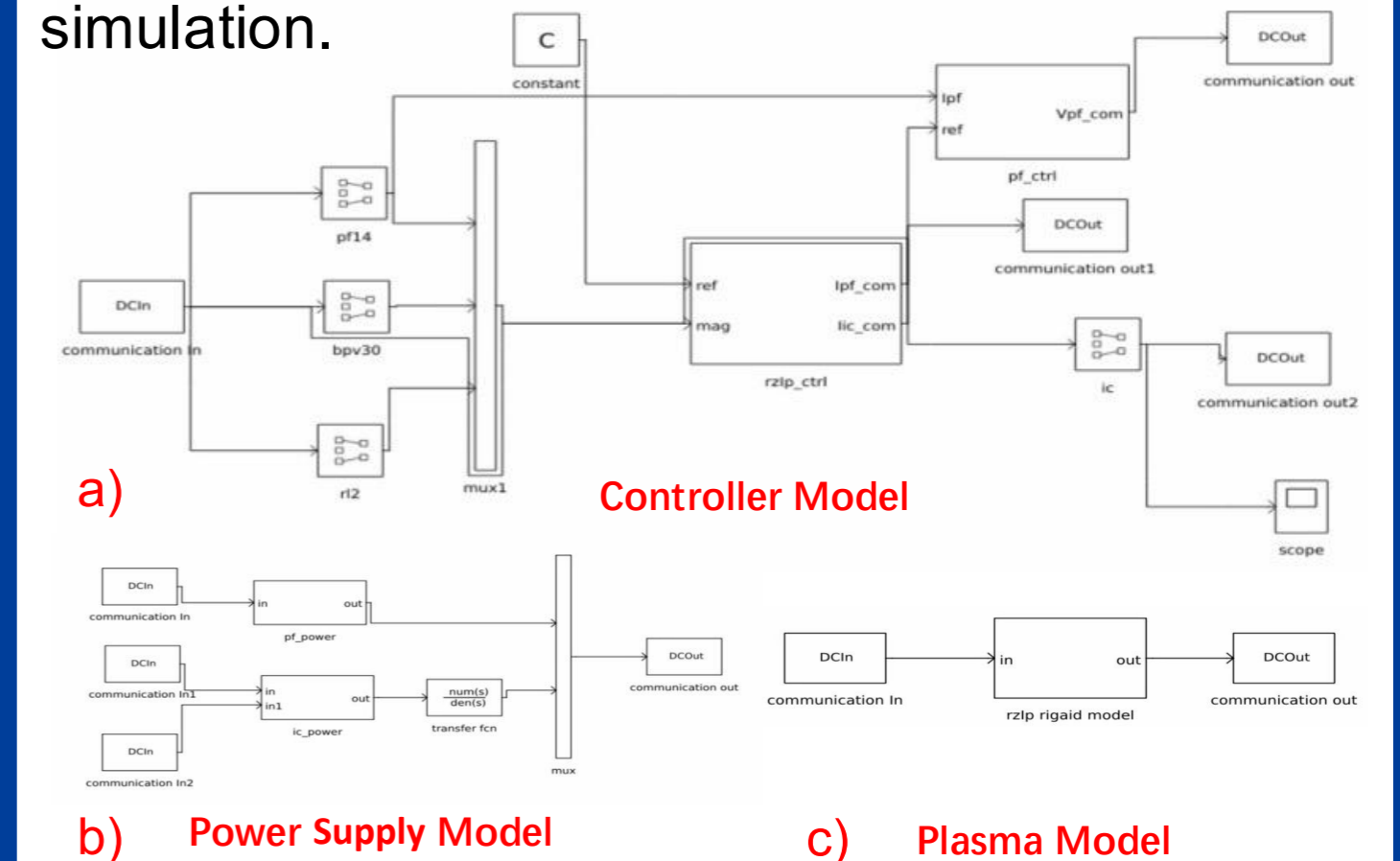

Fig. 4. Port connection coordination mechanism between distributed models

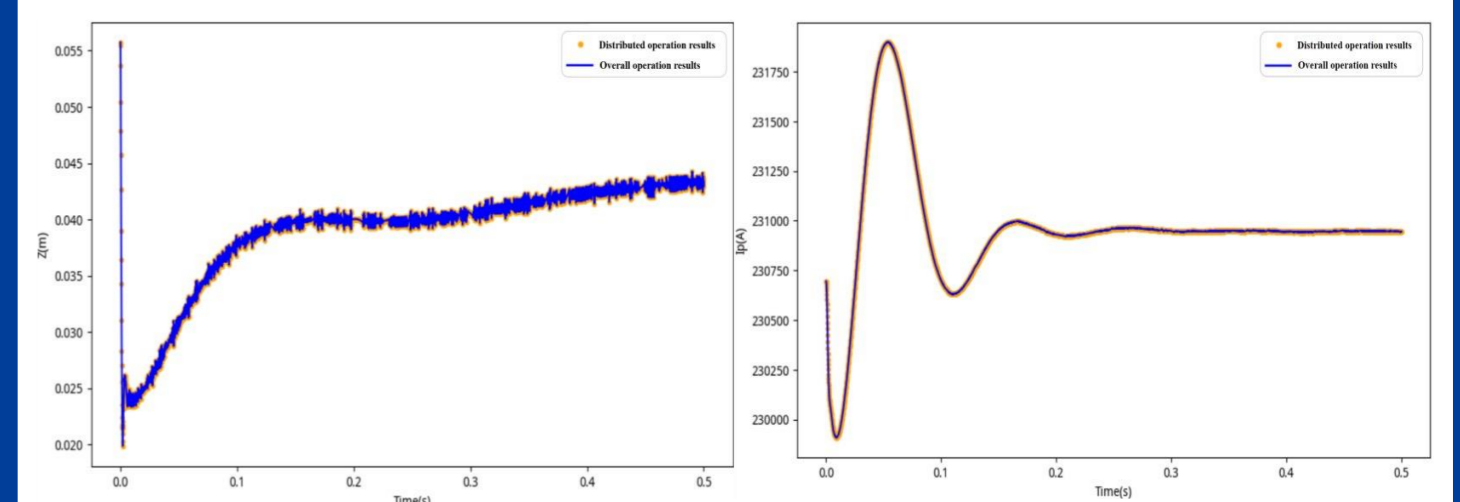

Fig. 5. Port connection coordination mechanism between distributed models

Results show that:

- Distributed and monolithic simulations produce consistent waveforms;
- Closed-loop execution remains stable;
- Multi-rate subsystem coordination operates correctly.

These results demonstrate the effectiveness of the proposed distributed simulation methods and mechanisms.

Contributions

- ① Distributed collaborative simulation method for digital tokamaks;
- ② Low-intrusion distributed decomposition method;
- ③ Multi-rate asynchronous simulation mechanism;
- ④ Centralized topology coordination mechanism;
- ⑤ Distributed model management method.

Distributed Collaborative Simulation Method

① Distributed Collaborative Simulation

Subsystem models are deployed on distributed simulation nodes and connected through standardized interfaces. A master-node coordination mechanism manages:

- Node registration;
- Model synchronization;
- Connection establishment;
- Simulation scheduling.

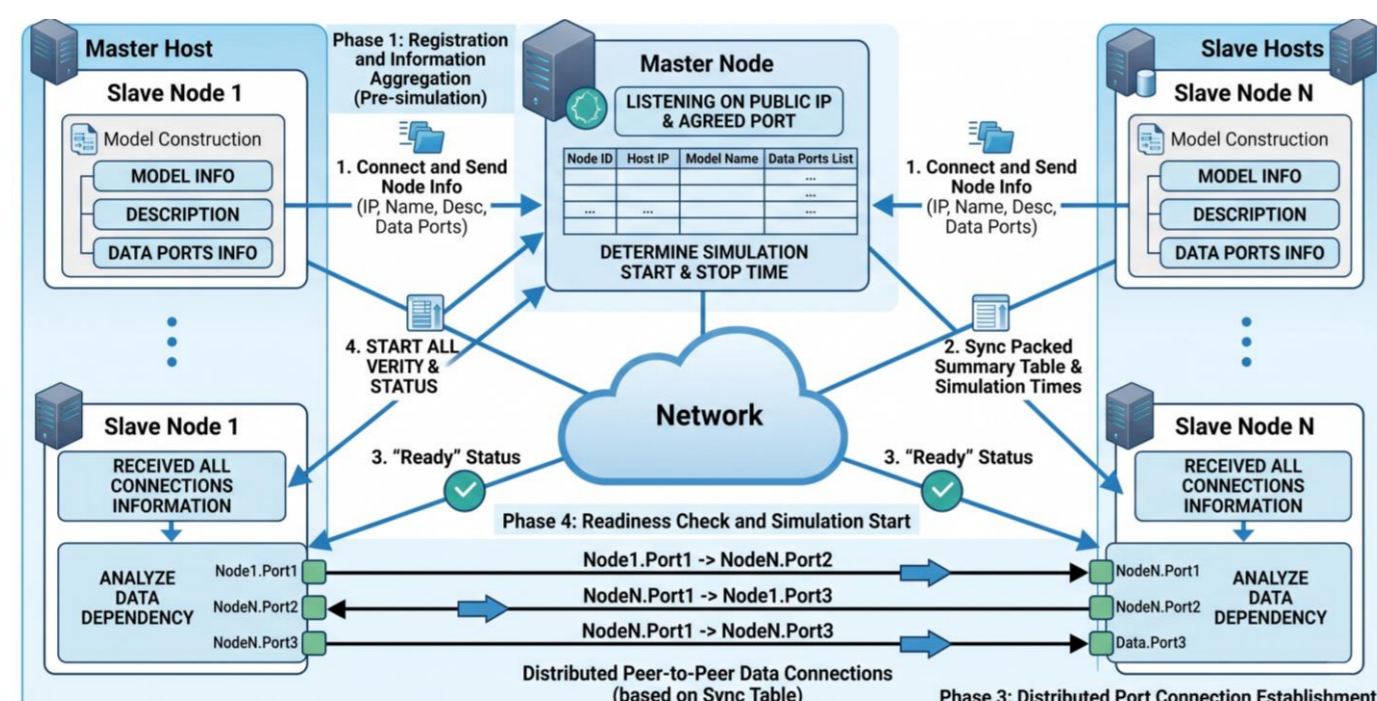

Fig. 1. Port connection coordination mechanism between distributed models

② Low-Intrusion Distributed Decomposition

A central-controller-based decomposition method is proposed for distributed closed-loop simulations.

The controller performs:

- Global topology reconstruction;
- Hidden loop analysis;
- Global starting-point determination;
- Implicit dependency injection.

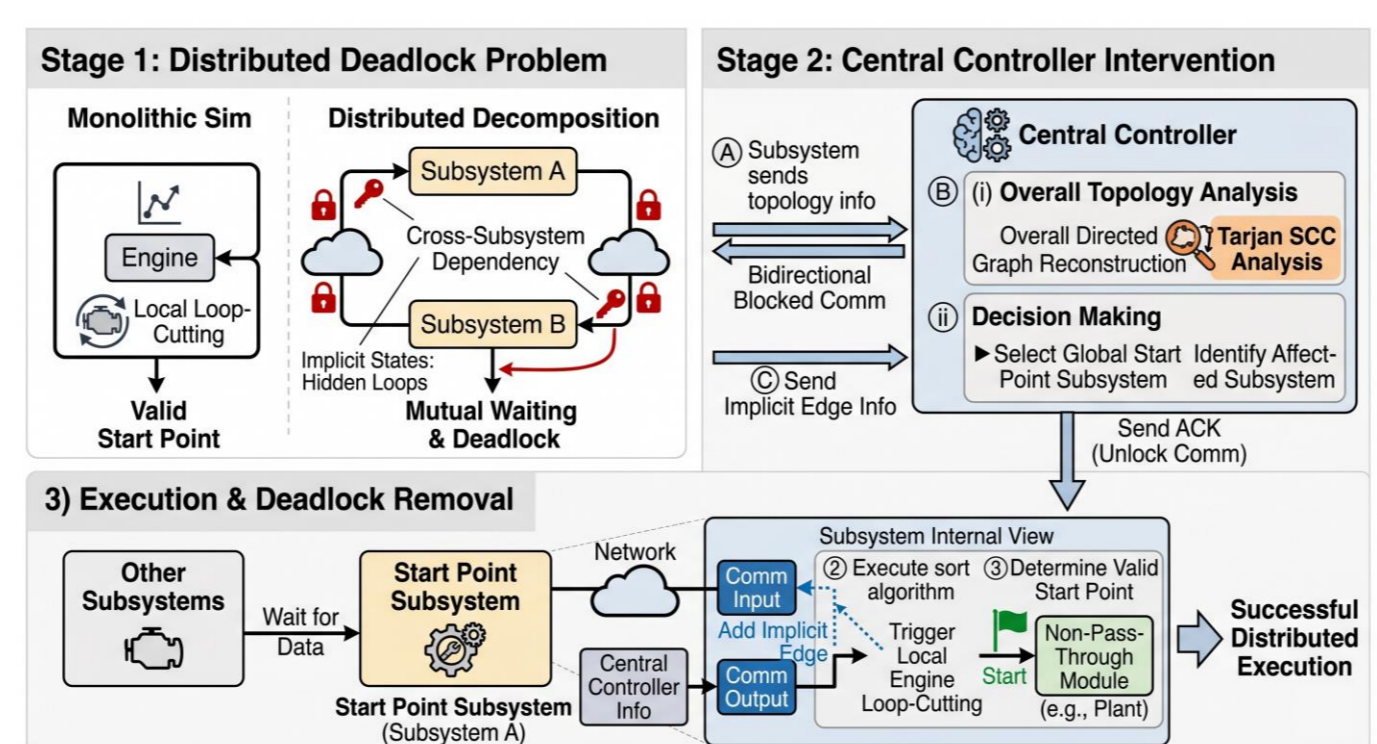

Fig. 2. Simulation execution order establishment mechanism

③ Multi-Rate Asynchronous Co-Simulation

Different subsystem models operate at different frequencies and time scales. A multi-rate asynchronous mechanism based on:

- Timestamp alignment;
- Asynchronous buffering;
- Historical data access;
- Causal blocking;

is introduced to support stable heterogeneous co-simulation.

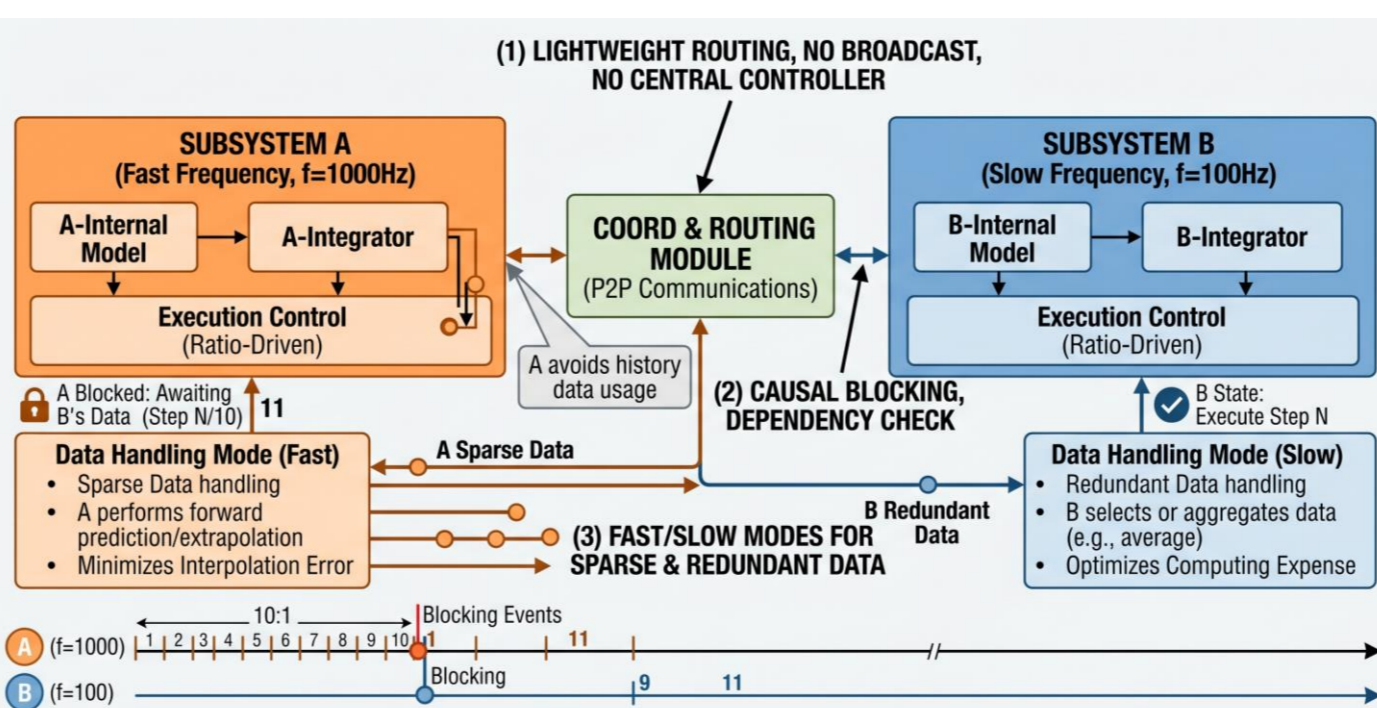

Fig. 3. A multi-rate asynchronous mechanism

④ Distributed Model Management Method

A distributed model management method is proposed to support large-scale collaborative modeling and continuous model iteration. The method provides:

- Standardized model organization;
- Distributed model management;
- Model sharing and reuse;
- Collaborative development support;
- Traceable model iteration.

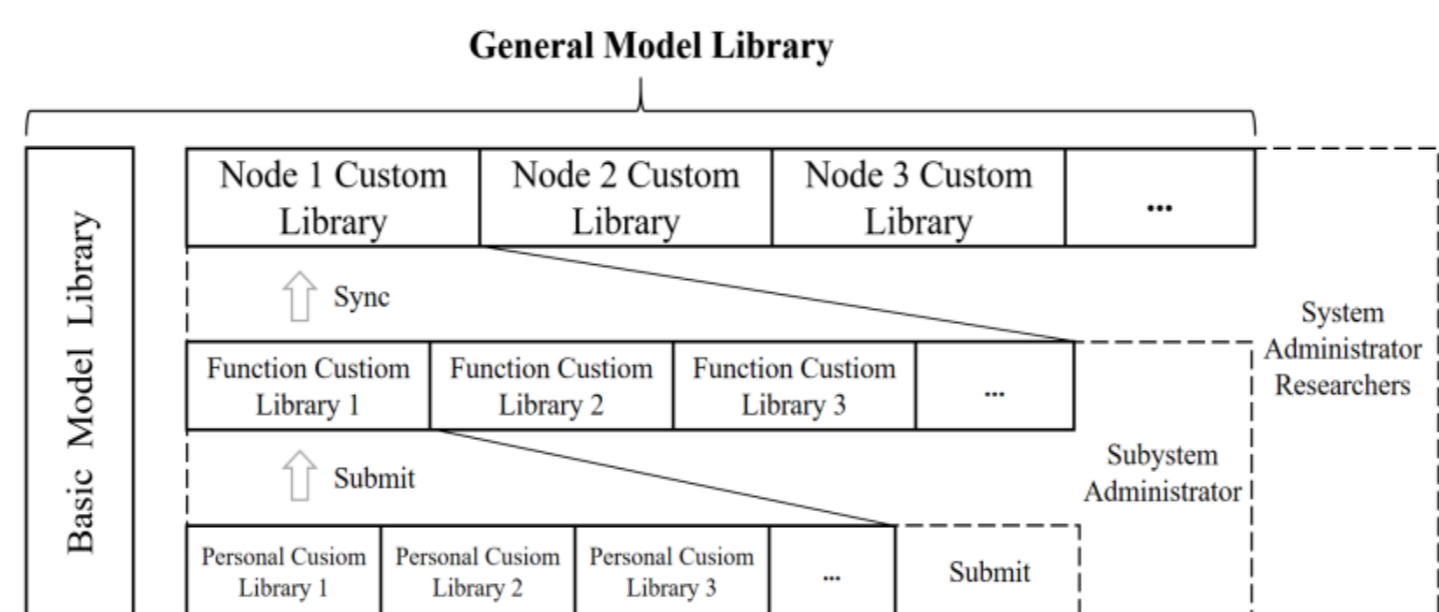

Fig. 4. Distributed model management pattern diagram

Conclusion

A distributed modeling and simulation method for digital tokamaks is proposed based on PCSVP. Through distributed collaborative simulation methods, low-intrusion decomposition methods, multi-rate asynchronous simulation mechanisms, and distributed model management methods, the proposed solution enables scalable large-scale co-simulation and efficient collaborative development.