

Development of Algorithms for the End-To-End System Simulation, Mode Analysis and Performance Optimization for a Generic and Multi-Tokamak High-frequency Magnetic Diagnostic System

presented by Duccio Testa, Swiss Plasma Center (SPC), EPFL

Alessandro Pau, Clelia Marie Albert, Filippo Bertini, Jan Jakub Frybes, Jean-Pierre Svantner

Ecole Polytechnique Fédérale de Lausanne (EPFL), Swiss Plasma Center (SPC), CH-1015 Lausanne, Switzerland

An innovative and very detailed end-to-end system modelling and analysis tool has been developed and applied to test on simulated and real data the actual measurement capabilities of a generic high frequency (HF) magnetic diagnostic system. This software package can run both in real-time (RT) and post-pulse, and it is applicable to both discrete (Mirnov and LTCC) and extended (Saddle Loops) inductive magnetic sensors. This package can be run in a multi-tokamak environment through appropriate interfacing with the EuroFusion IMAS and DEFUSE frameworks, and it is applicable to both existing, such as TCV and JET, and foreseen tokamaks, such as ITER, DTT, and DEMO. The main goals of this RT-compatible software package are three-fold: (1) generate synthetic data to test the HF magnetic diagnostics and general analysis algorithms; (2) obtain estimates of the intrinsic measurement uncertainties and then assess the actual vs. intended system measurement performance for correctly detecting individual components in the frequency spectrum of HF magnetic instabilities; (3) analyse HF coherent modes to provide their most important and RT-relevant observables: mode frequency, amplitude and {toroidal, poloidal} mode numbers. This has paramount consequences for any RT application where, as an example, we wish to detect the onset of a magnetic island and then determine whether, and which, corrective actions need to be taken to stabilize the discharge. This end-to-end modelling tool has been initially applied on simulated data extracted from a large database of magnetic instabilities observed in the TCV and JET tokamaks, which include relatively low frequency (Neoclassical) Tearing Modes at $\sim[1 \rightarrow 10]$ kHz, fishbones and sawbones at $\sim[10 \rightarrow 30]$ kHz, Geodesic Acoustic Modes, Alfvén Eigenmodes and more generally Energetic Particle Modes in the range from 50kHz to multiMHz. When then using actual data from the different HF magnetic diagnostic systems available on these two existing tokamaks, this comparison allows testing the intended vs. the actual measurement performance and the RT control stability and effectiveness for these instabilities. The algorithm has then been adapted to account for the specific features of the ITER AJ (Mirnov and LTCC-1D) and AI (Saddle Loops) magnetic diagnostics as currently designed, hence testing their measurement capabilities, specifically for RT control applications. A test application is also finally developed for the magnetic diagnostic system currently foreseen for DEMO and DTT.

GENERAL WORKFLOW OF THE ANALYSIS PACKAGE

- STEP #1:** signal generation, from the nominal $true B_{TRUE}(k,t)$ and $\delta B_{TRUE}(k,t)$ to the one actually used for all the ensuing analyses for one single k-sensor $B_{MEAS}(k,t)$ and $\delta B_{MEAS}(k,t)$
- STEP #2:** signal generation, from the measured individual k-signal $B_{MEAS}(k,t)$ and $\delta B_{MEAS}(k,t)$ to the ensemble for ALL sensors used in the analyses $\{B, \delta B\}_{MEAS}(t)$
- STEP #3:** signal processing to attempt to obtain the nominal $true$ Eigenmodes used to construct $\{B, \delta B\}_{TRUE}(t)$, and all their main characteristics: frequency, amplitude, toroidal and poloidal mode numbers \rightarrow this step ends with the evaluation of the overall **Detection Score** for the analysis of each specific simulation

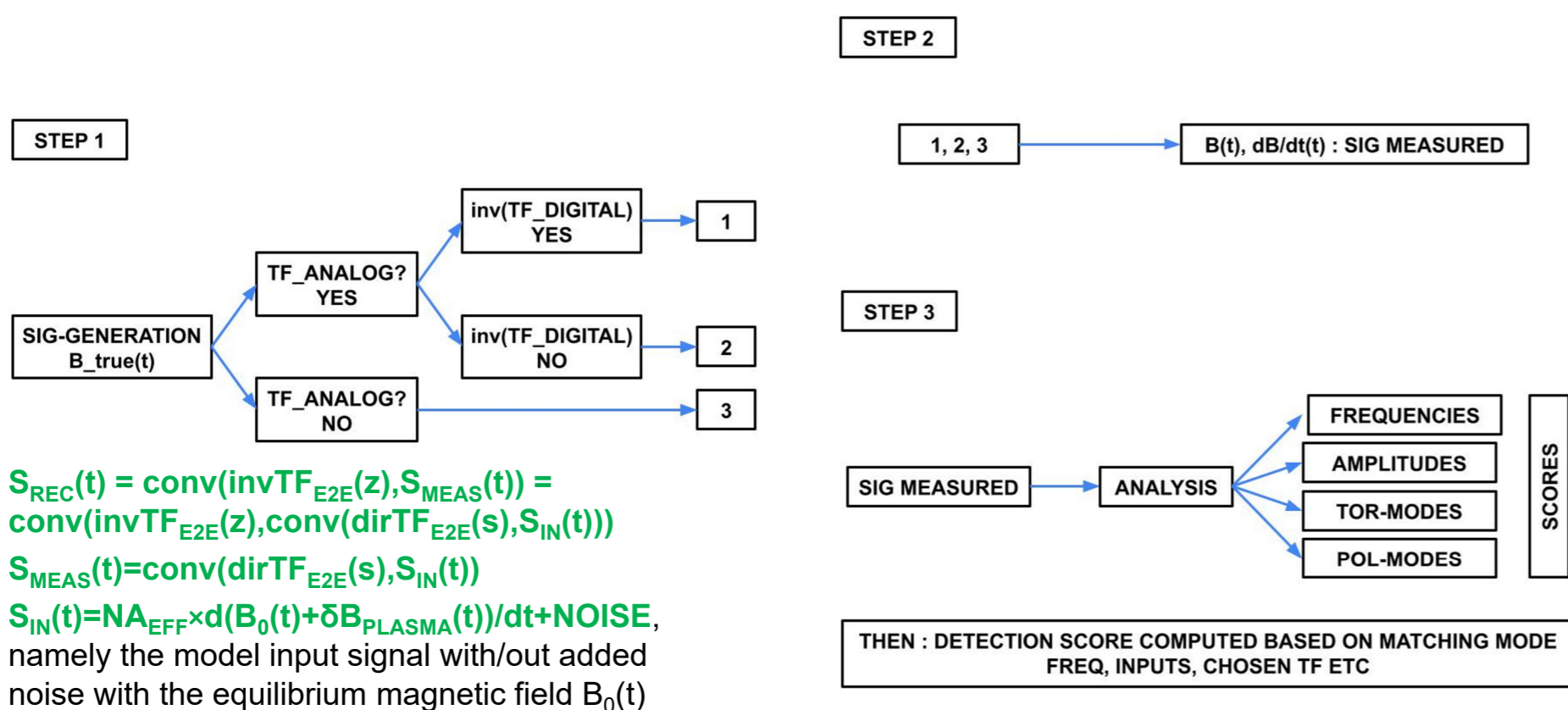

- $S_{REC}(t) = \text{conv}(\text{invTF}_{E2E}(z), S_{MEAS}(t)) = \text{conv}(\text{invTF}_{E2E}(z), \text{conv}(\text{dirTF}_{E2E}(s), S_{IN}(t)))$
- $S_{MEAS}(t) = \text{conv}(\text{dirTF}_{E2E}(s), S_{IN}(t))$
- $S_{IN}(t) = NA_{EFF} \times d(B_0(t) + \delta B_{PLASMA}(t))/dt + \text{NOISE}$, namely the model input signal with/out added noise with the equilibrium magnetic field $B_0(t)$

SCHEMATIC BLOCK-DIAGRAM FOR THE DAQ FOR THE MAGNETIC DIAGNOSTIC SYSTEMS IN ITER: SIGNAL CALIBRATION

- Analogue TF(s):** model the end-to-end direct analogue transfer function $\text{dirTF}_{E2E}(s)$, directly from measurements and/or using known values for the {sensors, cabling, DAQ-modules} electrical characteristics
- Digital TF(z):** construct the end-to-end inverse digital transfer function $\text{invTF}_{E2E}(z)$, where $z = \exp(st_{SDAQ})$ is the digital variable and $t_{SDAQ} = 1/f_{SDAQ}$ is the acquisition sampling time, using different models: bilinear (Tustin), **Levy-Denis-Schnabel** (LDS), Impulse Invariant Discretization (IID) to account for different features in the signal/analyses
- There are then three signals that can be analysed, and the results compared for:
 - $S_{IN}(t)$, namely the model input signal with/out noise;
 - $S_{MEAS}(t) = \text{conv}(\text{dirTF}_{E2E}(s), S_{IN}(t))$, namely the model input signal convoluted with $\text{dirTF}_{E2E}(s) \rightarrow$ the actual nominal measurements at the end of the whole DAQ line \rightarrow hence **POSSIBLY VERY DIFFERENT FROM $S_{IN}(t)$!**
 - $S_{REC}(t) = \text{conv}(\text{invTF}_{E2E}(z), S_{MEAS}(t)) = \text{conv}(\text{invTF}_{E2E}(z), \text{conv}(\text{dirTF}_{E2E}(s), S_{IN}(t))) \rightarrow$ the fully calibrated signal, which in principle should resemble $S_{IN}(t)$ more closely than $S_{MEAS}(t)$

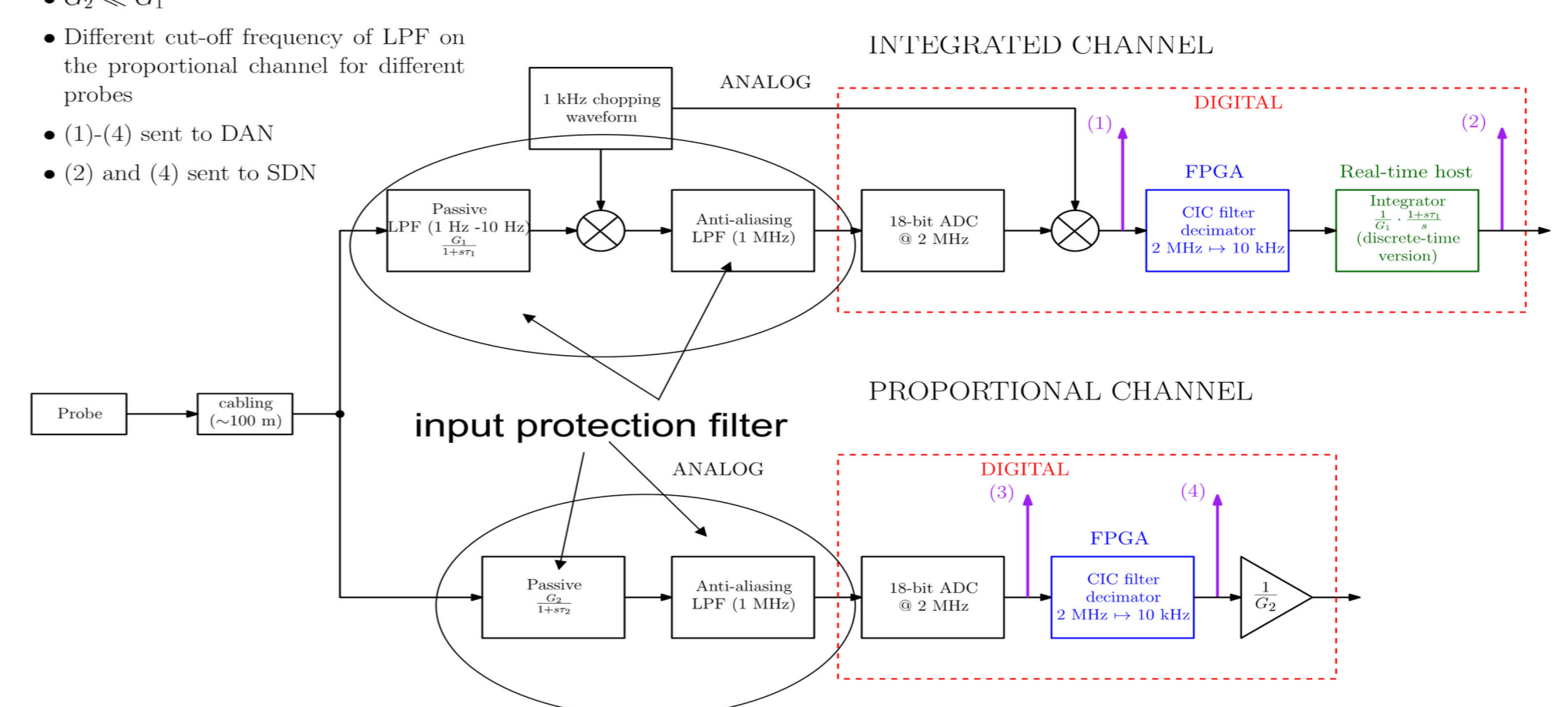

IMPLEMENTATION OF MULTIPLE SOURCES OF NOISE

- in-vessel noise due to pick-up of spurious signals from nearby power-supplies for active coils: wideband up to ~ 10 kHz, multi-colours and multi-harmonics
- ex-vessel noise due to pick-up of spurious signals from nearby power-supplies for active heating systems (NBI, ICRF, ECH): wideband up to ~ 100 kHz, multi-colours and multi-harmonics
- ex-vessel electrical and bit noise in the DAQ: wideband up to the DAQ acquisition frequency f_{SDAQ} , single-colour

PRODUCING A RELEVANT SYNTHETIC SIGNAL

$$S_{IN,k}(\omega; \{\phi, \theta\}_k; t_p) = \{ \text{Impulses}(\omega; t_p) \}_k + \{ \text{NOISE}(\omega; t_p) \}_k + \left\{ \begin{array}{l} \cos(\alpha(\theta_k)) \\ \sin(\alpha(\theta_k)) \end{array} \right\} \int_{-\infty}^{\infty} d\omega_{CONT}(\omega, t_p) + \sum_{n,m} A_{n,m} \exp(-in\phi_k) \exp(-im\theta_k) \exp(-i\omega_{n,m}t_p)$$

$\delta B_{PLASMA}(t)$ is a time series with a continuum background (EM fluctuations), multiple discrete temporal and spatial components (Eigenmodes), frequency- and time-dependent noise, impulses (discrete events: ELMs, sawteeth, pellets, etc ...) and accounts for the position and orientation of the sensor as mounted on the wall

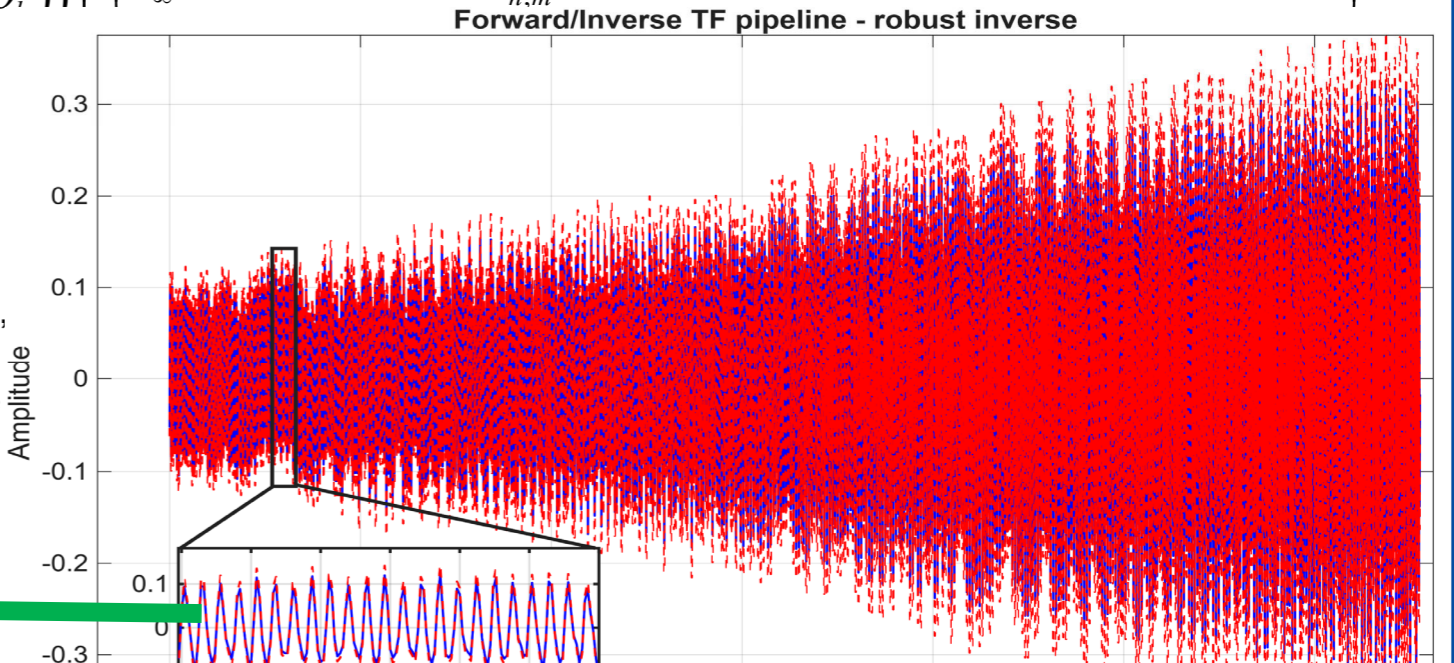

EXCEPTIONALLY ROBUST SIGNAL CALIBRATION PIPELINE MAKES $S_{REC}(t)$ AND $S_{IN}(t)$ VIRTUALLY INDISTINGUISHABLE

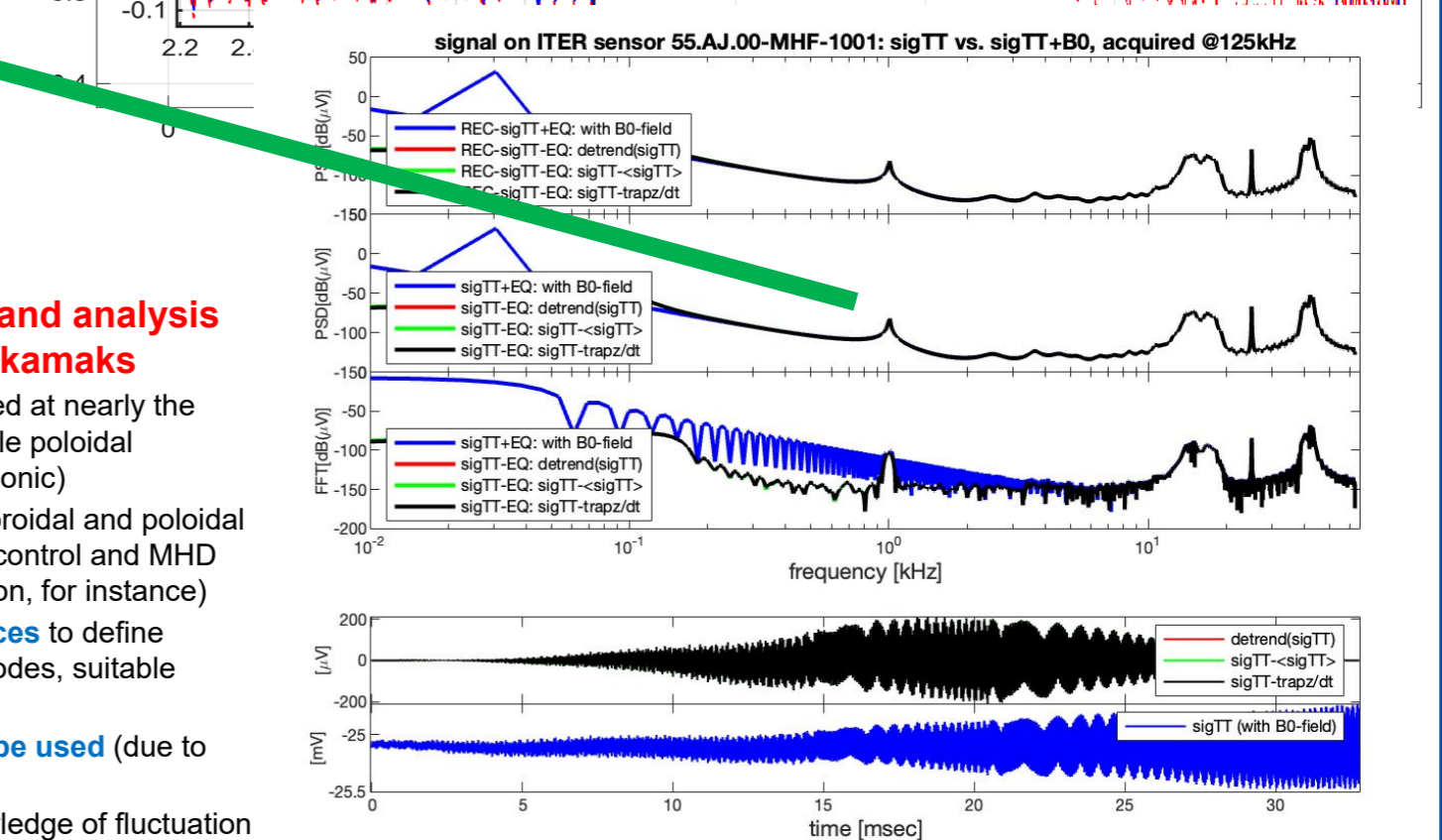

- challenges for measurement and analysis of magnetic fluctuations in tokamaks**
- multiple degenerate modes expected at nearby the same frequencies (usual case: multiple poloidal harmonics for the same toroidal harmonic)
- need precise ± 1 determination of toroidal and poloidal mode numbers for (active) feedback control and MHD spectroscopy (island width and location, for instance)
- must satisfy measurement tolerances to define correct and wrong detection of the modes, suitable thresholds then have to be defined
- uneven spatial sampling needs to be used (due to potential loss of sensors over time)
- blind RT analysis: no previous knowledge of fluctuation spectra can/should be used

IMPLEMENTING THE CALCULATION OF THE DETECTION SCORE FOR SYNTHETIC DATASETS

The **Detection Score** (DS) for each simulation/analysis is computed as follows:

- DS calculated separately for the toroidal and poloidal analyses
- DS=1.00 for perfect detection, penalized using the joint probability function of obtaining the output results, with their intrinsic error σ_{OUT} over each simulation run, and then the scatter over all N_{SIM} simulations, within the input values with their intrinsic expected measurement accuracy σ_{IN}
- DS further penalized proportionally to the bi-directional number of missed components, namely input (output) components that are NOT found in the output (input)

$$DetectionScore(y_{IN}) = \int_{-\infty}^{+\infty} dx \frac{1}{\sqrt{2\pi}\sigma_{IN}} \exp\left[-\frac{(x - y_{IN})^2}{2\sigma_{IN}^2}\right] \times \int_{-\infty}^{+\infty} dx \frac{1}{\sqrt{2\pi}\sigma_{OUT}} \exp\left[-\frac{(x - y_{OUT})^2}{2\sigma_{OUT}^2}\right] - \text{penalty}(\text{MissedModes})$$

Penalty for Missed Modes (PMM)

- Input spectrum with K modes
 - Expecting K output modes
 - Possibly 2K bi-directional missed components
 - If we fail them all, then we must have DS=0
- \rightarrow **PMM=1.00/2K for each missed bi-directional component**

IMPLEMENTING MULTIPLE ANALYSIS METHODS

- Frequency decomposition: temporal-FFT and PSD analysis using multiple methods (periodogram, ARMA models)
- Spatial decomposition –toroidal and poloidal: spatial-DFT (tor-only), Linear Phase Fit (LPF) (tor+pol), Linear Signal Combination (LSC) (tor-only), Sparse Representation (SS-H2) (tor+pol)
- Toroidal mode number decomposition: time traces for the most RT-relevant modes**

SENSORS FOR THE ITER MAGNETIC DIAGNOSTIC SYSTEMS

- AJ sensors:** ~ 50 x Mirnov-1D and ~ 250 x LTCC-1D, for LF and HF measurements
- max. HF effective bandwidth ~ 350 kHz limited by cabling length ~ 100 m
- measurements capabilities up to toroidal/poloidal mode numbers $|n| \sim 20$ and $|m| \sim 35$
- useful for measuring HF Tearing Modes, and Energetic Particle Modes
- signals usable in real-time for plasma control vs. magnetic instabilities
- AJ saddle loops:** only LF measurements
- effective bandwidth ~ 5 kHz determined by wall time constant $\tau_{wall} \sim 30$ msec
- useful for measuring low $[m,n]$ modes
- useful for measuring LF Tearing Modes, Resistive Wall Modes and Locked Modes

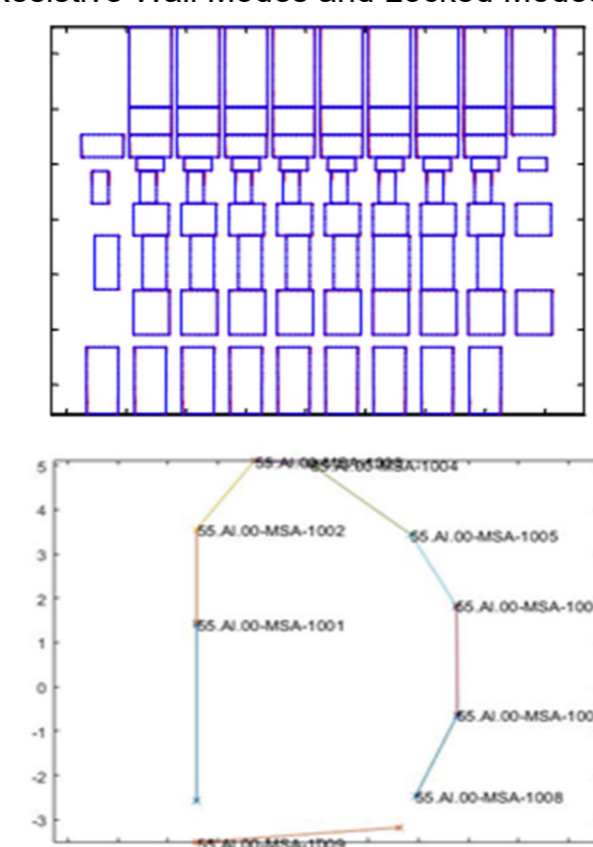
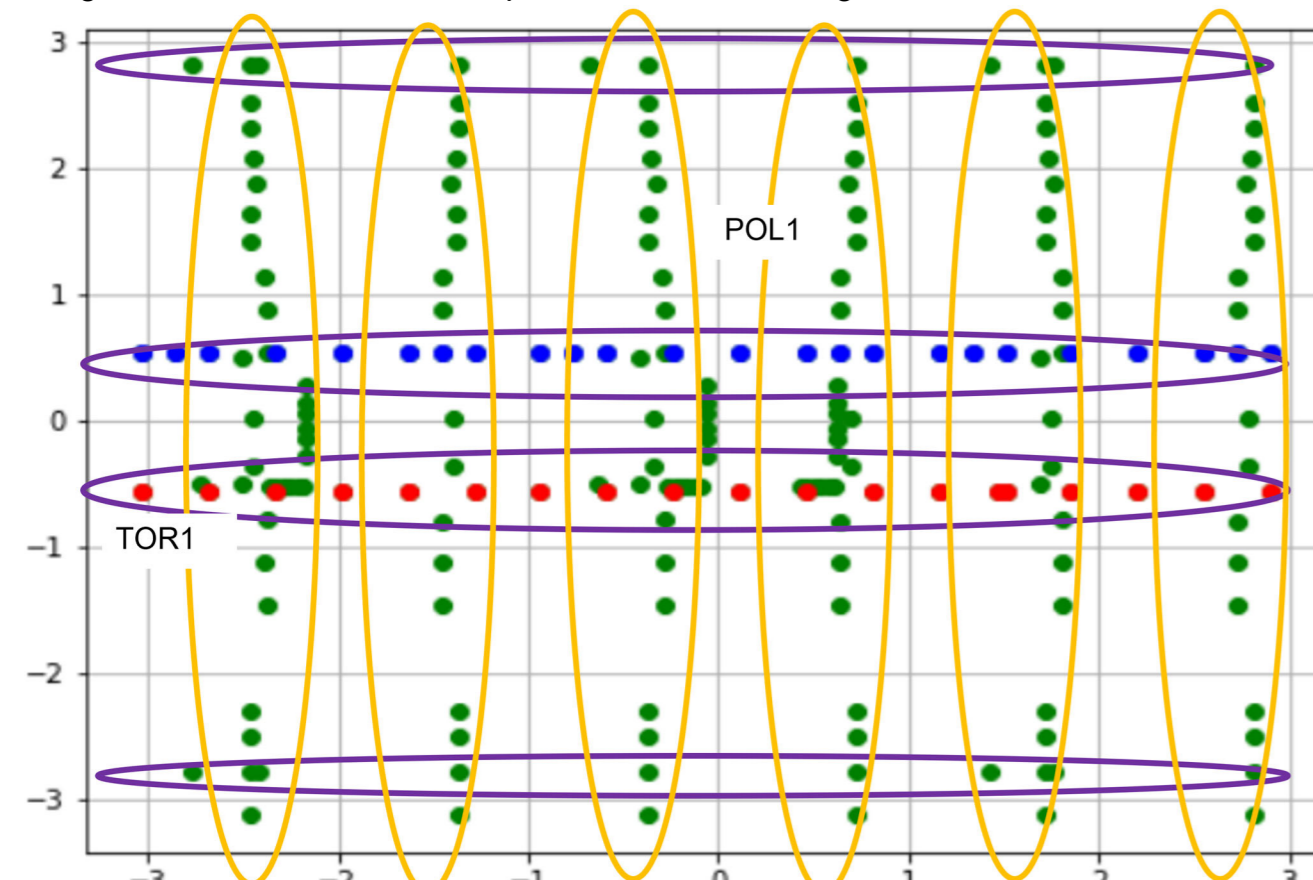

CONCLUSIONS

- A software package has been created and is being developed to professional standards to analyse real and synthetic data for a generic high-frequency magnetic diagnostic system for a generic tokamak fusion device
- The analysis package includes end-to-end propagation of errors from the diagnostic side to the methods employed for the different analyses
- The analysis package allows to obtain the detection score for any HF magnetic diagnostic system comparing multiple analysis methods, allowing detailed knowledge of the actual measurement capabilities of the diagnostics
- All these steps allow forecasting the actual measurement capabilities for real-time applications: detection (and then control) of a large spectrum of magnetic instabilities**
- Integration within the EuroFusion IMAS and DEFUSE analysis frameworks is ongoing, for deployment on ITER and DTT**
- Upon suitable agreement, the analysis package can be distributed to interested users worldwide**