

Application of the FPGA Coprocessor TM FAST for Siemens S7-1500 PLCs in Neutron Scattering

H. Kleines, JCNS, Forschungszentrum Jülich

Abstract: The Siemens FPGA Coprocessor TM FAST for Siemens S7-1500 PLCs support processing times in the order 50ns, which is several magnitudes below the PLC cycle time, as well as count rates in the order of a few MHz. Since TM FAST supports isochronous mode, the TM fast processing cycle can be synchronized with PLC tasks as well with the PROFINET or PROFIBUS decentral devices. This allows the usage of TM FAST in motion applications, e.g. for the readout of encoders with protocols not support by standard Siemens PLC modules or for the synchronization between detectors and motion axes.. Another typical application is the readout of simple detectors, e.g. neutron monitors or Helium-3 proportional counters. Due to the lower limit of PLC cycle times and the limited IO size of TM FAST, it has only limited capabilities for the readout of time resolved detectors which requires careful consideration.

Siemens TM FAST

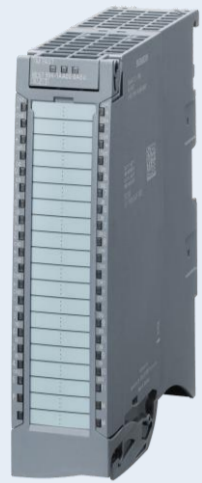

- FPGA coprocessor for S7-1500
- central or decentral (ET 200MP) configuration
- Supports **isochronous mode** => suitable for motion applications
- 24 V IOs: 200 kHz
- 5 V IOs
 - RS485/RS422: 2 MHz
 - TTL: 200 kHz
 - Signal type, direction, termination, delay configurable in FPGA code

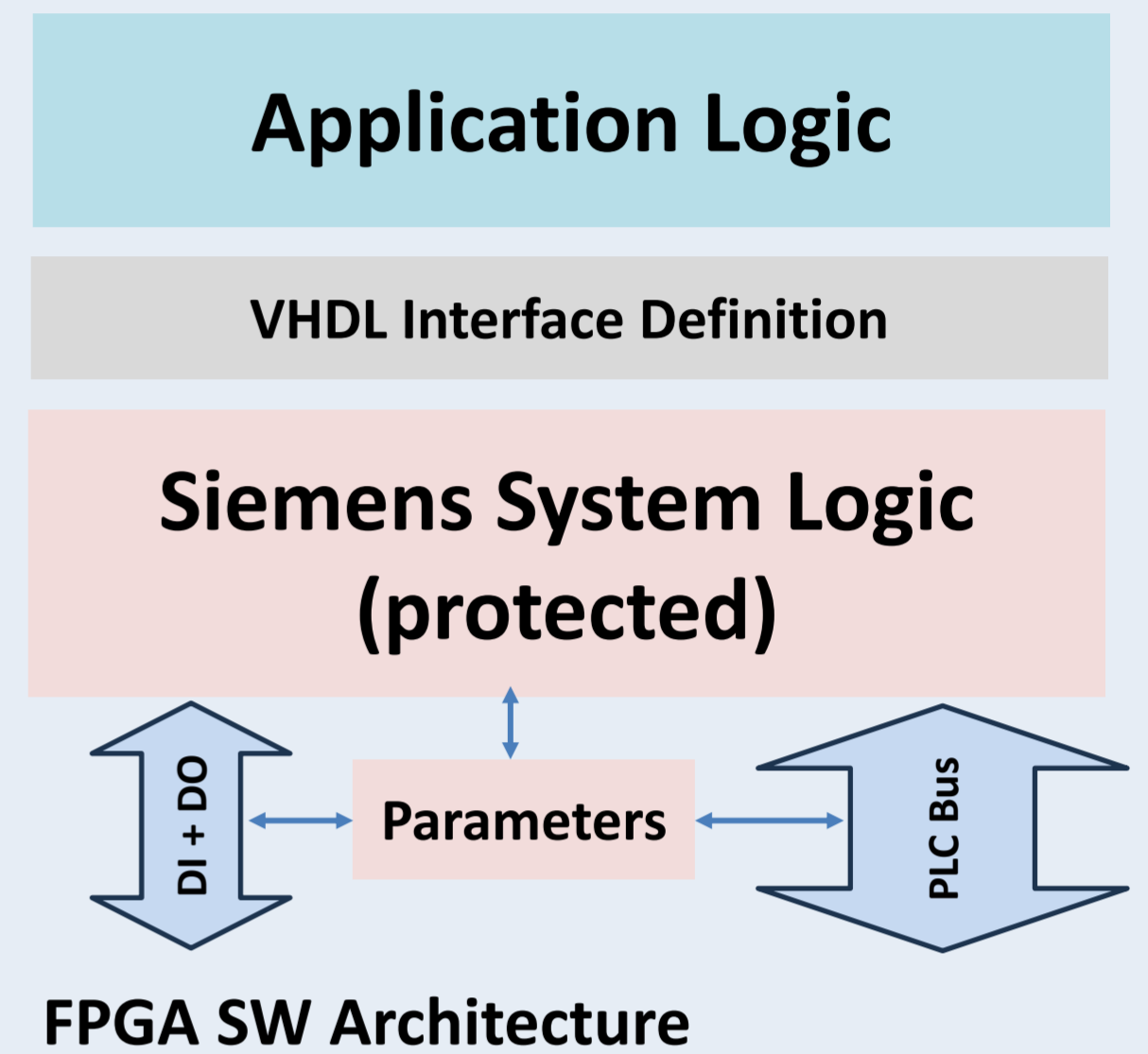
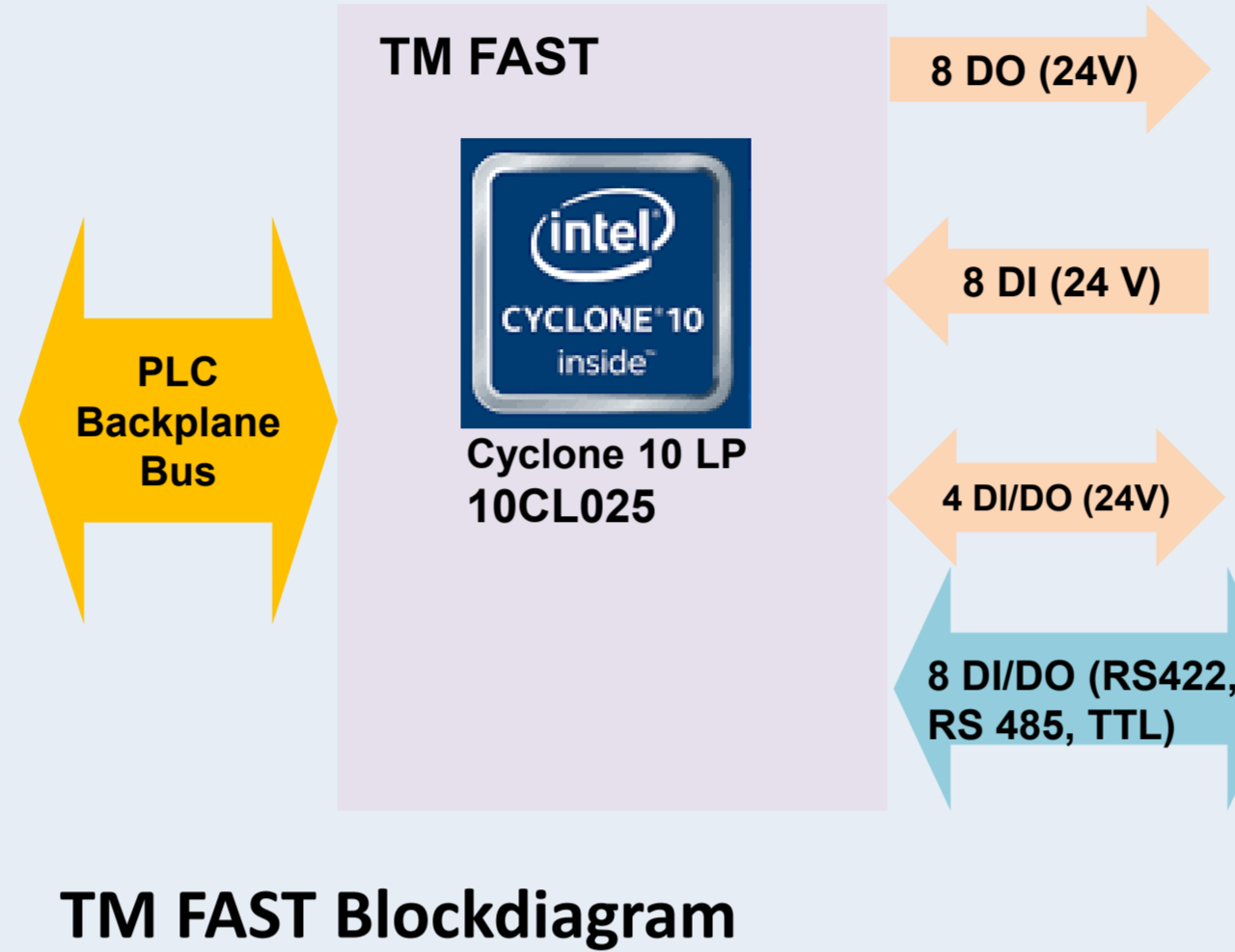

Development/Test System

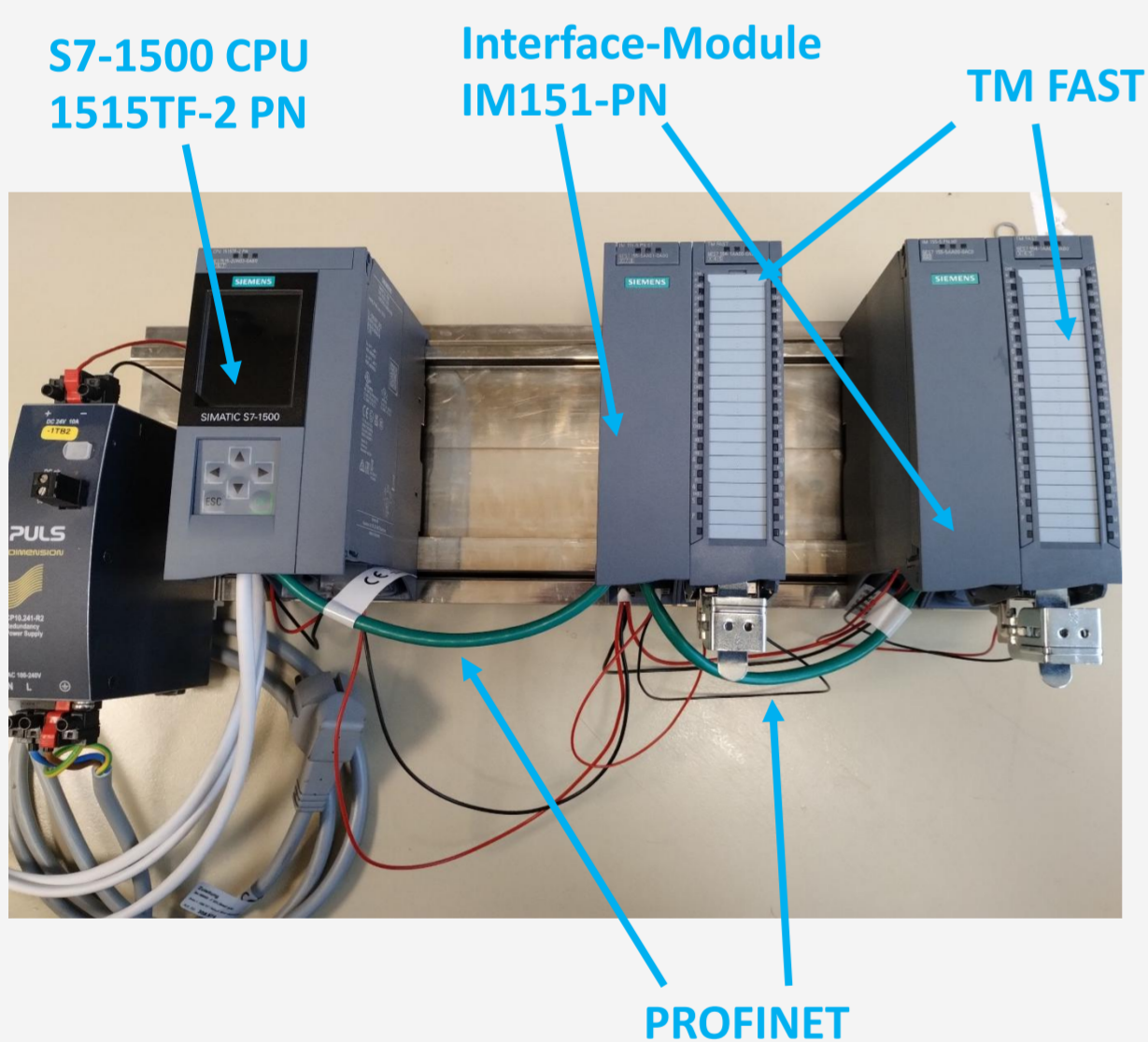

Required Tools

- Intel® Quartus® Prime Lite Edition
 - Synthesis, place&route,....
- Questa-Intel FPGA Starter Edition
 - Simulation
- Siemens Multi FieldBus Configuration Tool (MFCT)
 - Image file creation + download
- Intel FPGA Download Cable (USB-Blaster)
 - Debugging, alternative download option
- TIA Portal Library LTMFAST
- In GitHub: Few VHDL examples provided by Siemens

Possible Applications

- Fast Digital IO
 - Oversampling possible
 - PWM,
 - pulse train output
 - Timers,
 - counters,
- Encoder readout
 - Hiperface, Endat, Biss-C
 - SSI-Encoders with non-standard position resolution
-

Application 1: SSI Encoder Readout

- Nanotec stepper motor ST4118 with NM1-SSI encoder
- SSI frame: 51 bit long with 33 Bit position value
- not supported by Siemens TM PosInput 1 and 2.
- Open source VHDL code for SSI encoder in a TM Fast environment available from Siemens in GitHub => Modification of Siemens VHDL code



Application 2: ³He Neutron Proportional Tube readout

- Count Rate: order of 100 kHz
- Dead Time: order of 1 μs
- Classical solution: CPCI counter module
- Avoid CPCI?
- Port CPCI Counter FPGA code to TM Fast
- Conversion of NIM + TTL to RS422 required
- Discriminator output pulse duration too short?
- Non-time-resolved mode: Performance of TM Fast ok
- Time-resolved mode: TM Fast only possible with monitor tubes due to restricted data width (32 Bytes)

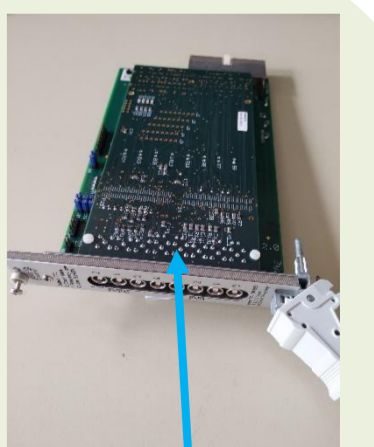

CPCI Counter Module

