

25nd IEEE Real Time Conference

Repurposing acquisition devices into trigger-based timing synchronization of break-down events during MITICA high voltage holding experiments

A. Rigoni Garola¹, L. Lotto^{1,2}, G. Manduchi^{1,3}, T. Patton¹, R. Ghiraldelli³, C. Taliercio^{1,3},
M. Boldrin¹, L. Trevisan¹, P. Cinetto¹, P. Barbato¹, and G. Chitarin¹

¹*Consorzio RFX (CNR, ENEA, INFN, Università di Padova, Acciaierie Venete SpA), Corso Stati Uniti 4, 35127
Padova, Italy*

²*CRF - University of Padova, 35131 Padova, Italy*

³*Istituto per la Scienza e la Tecnologia dei Plasmi, CNR, Padova, Italy*

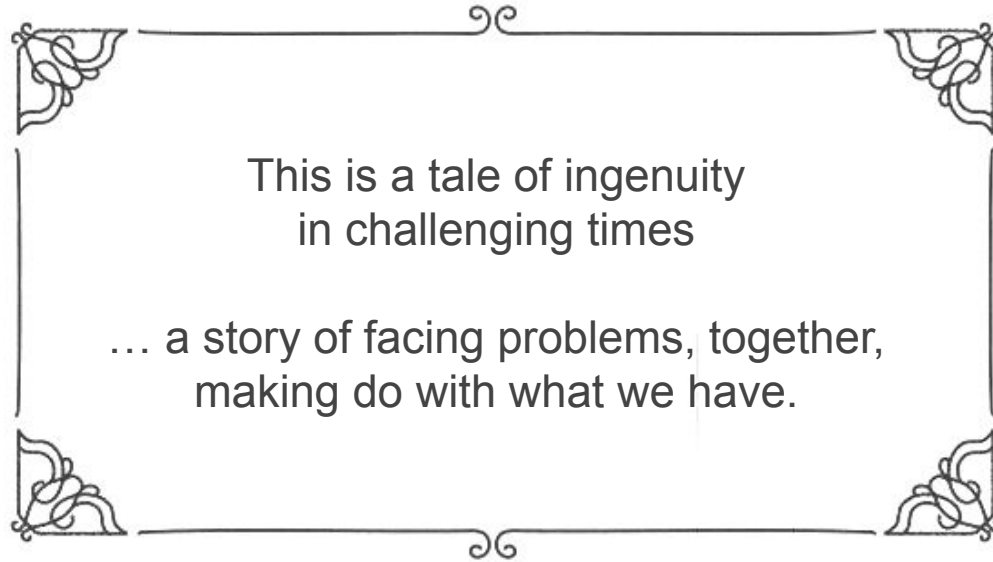

This is a tale of ingenuity
in challenging times

... a story of facing problems, together,
making do with what we have.

MITICA HV Holding Experiments

MITICA: a full-scale prototype of the heating Neutral Beam Injectors hosted at the Consorzio RFX Neutral Beam Test Facility, built for the ITER experiment.

Mitica is a particles accelerator that requires the capability to withstand a continuous voltage of **1MV** across the vacuum gaps insulating the beam source from the grounded vessel.

The HV Tests aim at verifying that the system can be successfully conditioned to sustain the 1MV continuous operation in the expected vacuum conditions ($1e-7 \sim 1e-4$ mbar).

Why Precise Timing of Currents:

The Main target for the arc-current sensors was to watch for the site of possible failures, by looking at the shape of signals and the actual relative timing between current waveforms along the line.

FORTUNATELY NO FAILURES HAVE BEEN OBSERVED DURING THE CAMPAIGN

All expected Breakdowns were located in BSV

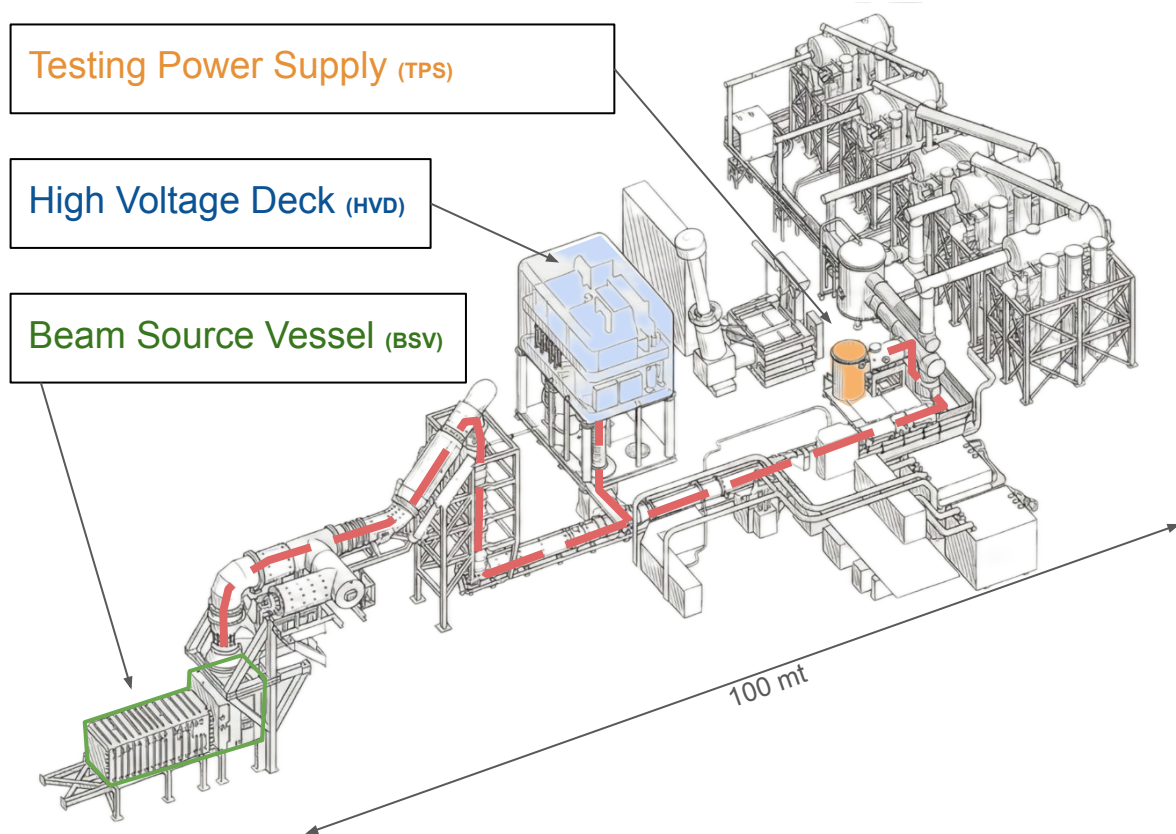

MITICA HV Holding Experiments

Long gap insulation in vacuum is a hard modelling problem, since the breakdown physics is still not completely understood and the phenomena are driven by many parameters: gas pressure, surface area of the electrodes, material compounds, surface roughness, local electric fields, glow effects, voltage ramp-up, specific geometry of components etc..

CONDITIONING PROCEDURE:

The chosen conditioning procedure consisted in the **repetitive reach of the breakdown voltage** with a first rapid ramp up to 90% of the last BD level, and a softer rising guided by pressure envelope, microcurrent activity, and X-ray radiation.

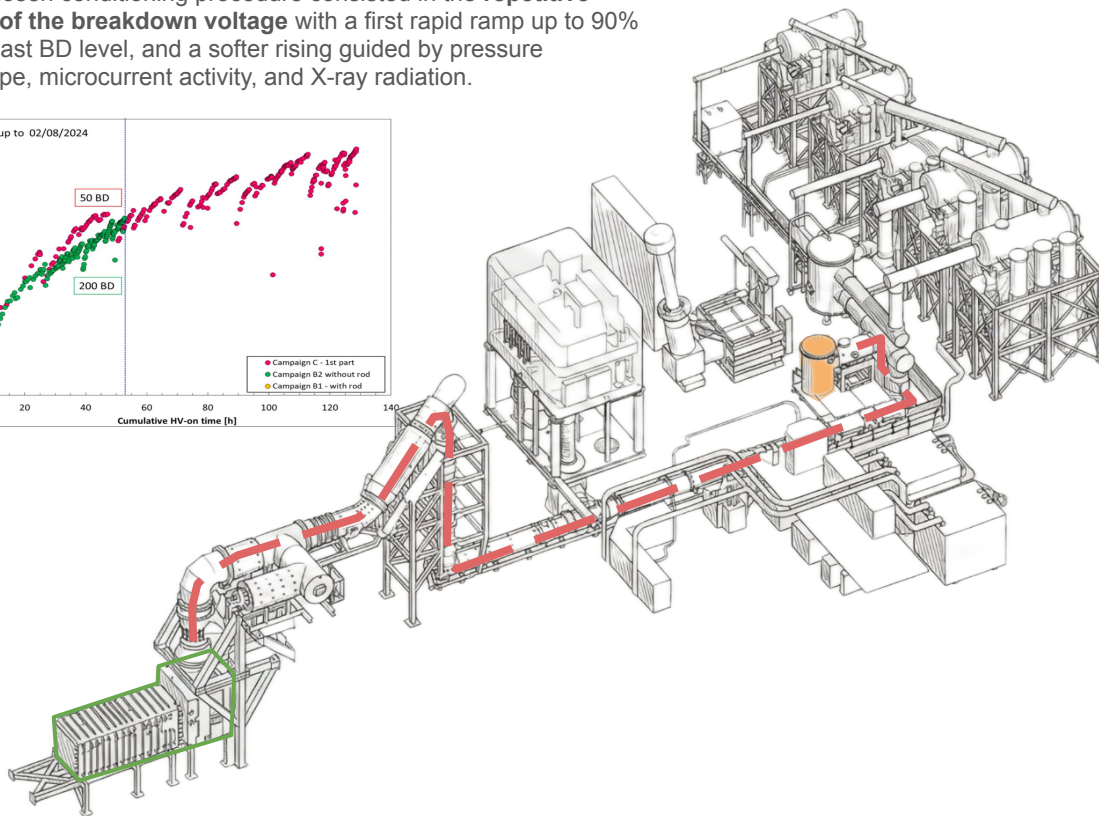
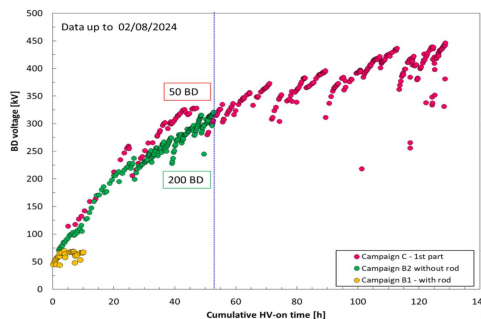
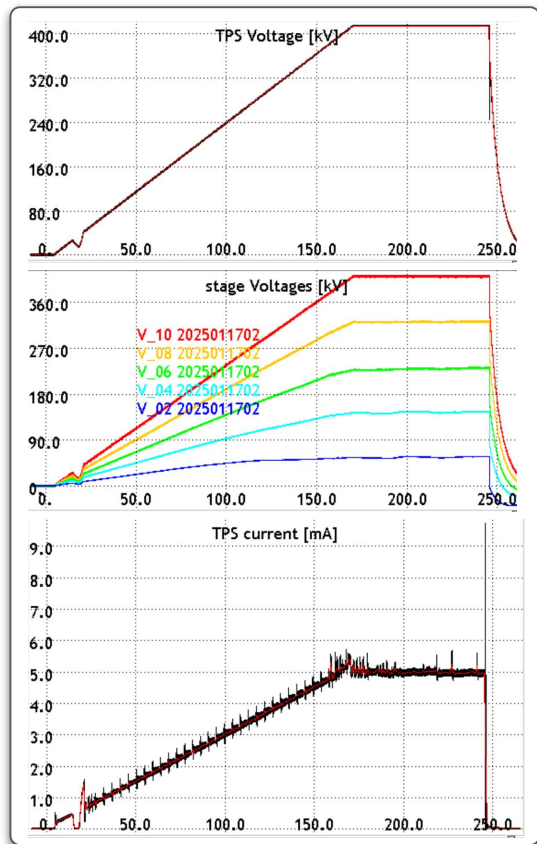

MITICA HV Holding Experiments

Strong insulation was the main requirement of the current diagnostic system: 4 fast current transformer (CT) with 17MHz bandwidth were placed inside the vacuum vessel to collect the impulsive arc current events, at the 1MV (ME10) electrode and at three large floor plates (GP00). Other 8 slow galvanic sensors were designed to acquire the micro currents associated with the pre-discharge activity in vacuum high voltage operations.

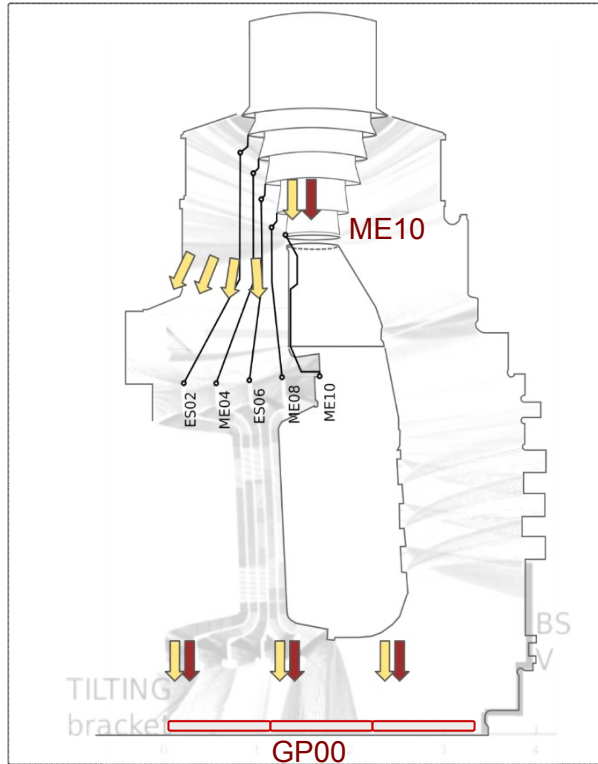

MAIN OBJECTIVES:

- Strong insulation
- At least 40MHz bandwidth
- Sub-microsecond time synchronization among BD sensors on “distant” components

SENSORS:

- 1 x ME10-CT (50kA 17MHz, 1 As)
- 3 x GP00-CT (50kA 17MHz, 1 As)
- 2 x Rogowski Coils (100kA, 1.8MHz)

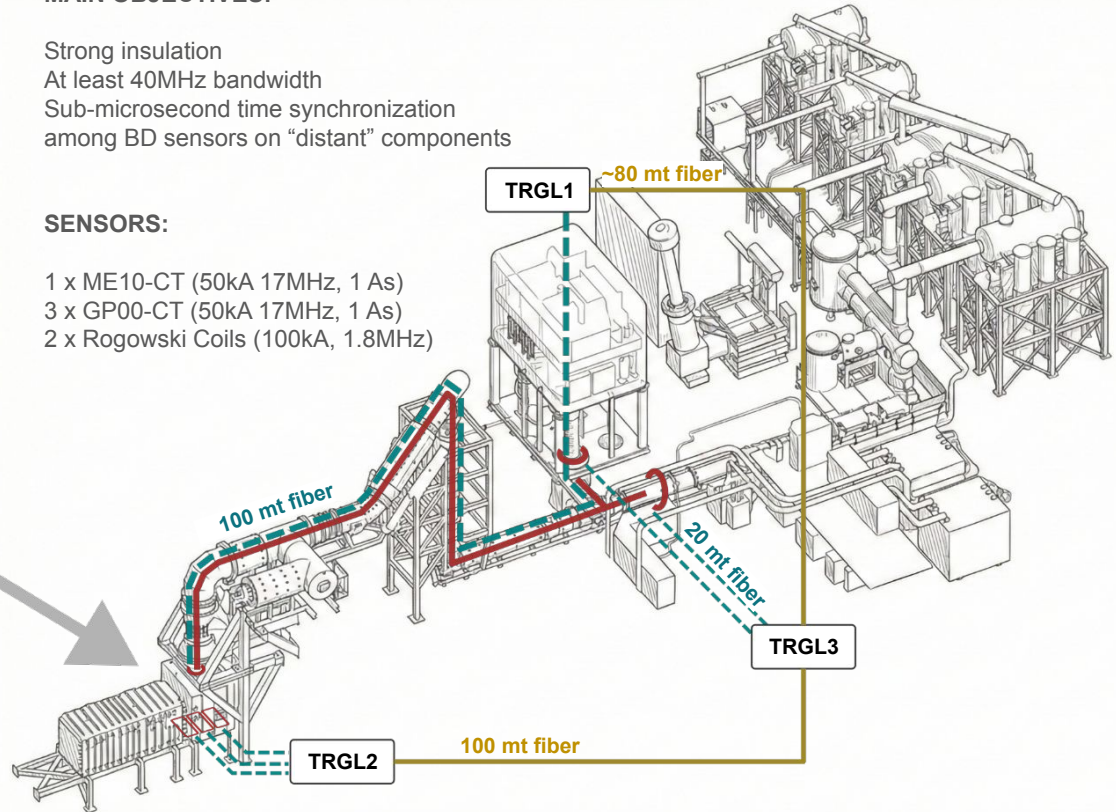

RedPitaya *rfx_stream* battery powered transient recorder

The HV CT signal is acquired by a StemLab 125-14 RedPitaya board having a 125 Msps input with a 14 bit ADC

The Main advantage of this choice has been the small form factor and the possibility to battery power the device to guarantee complete galvanic insulation.

A custom firmware (*rfx_stream*) has been implemented to convert RP into a stream transient recorder capable to be operated with MDSplus.

[13th IAEA TM 2021 CULHAM - RedPitaya applications at the NBTf beam source SPIDER](#)

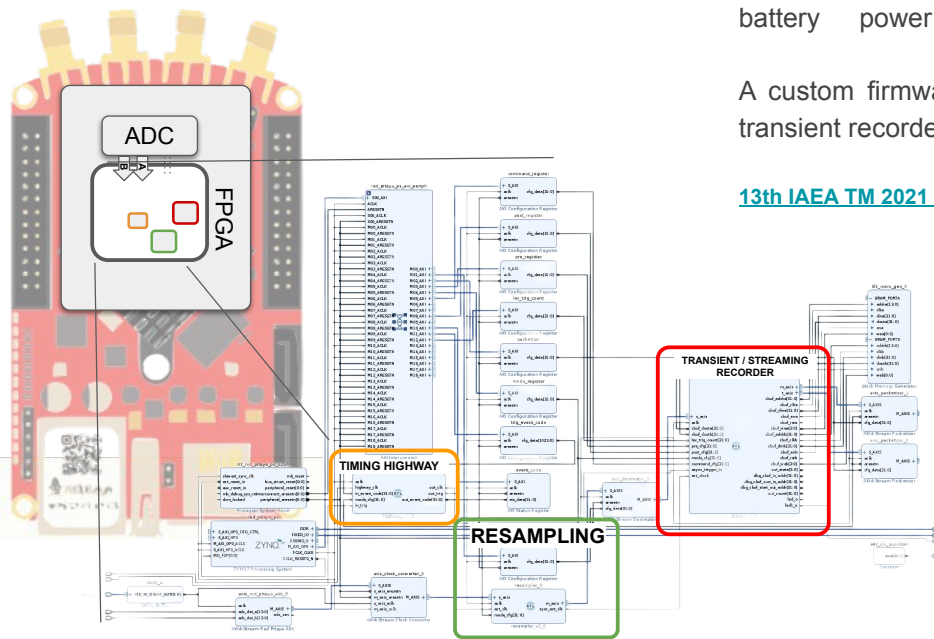

Characteristics of the firmware: (golden features of a transient recorder)

1. The recorder automatically re-arm
2. The clock can be considered constant within the transient
3. The recorder can listen **both** from internal and external trigger at the same time.
4. On **any** record event the board **generates a trigger out**
5. The **trigger source is recorded** for each transient
6. The pre-trigger buffer covers the max trigger delay on the overall interconnected devices

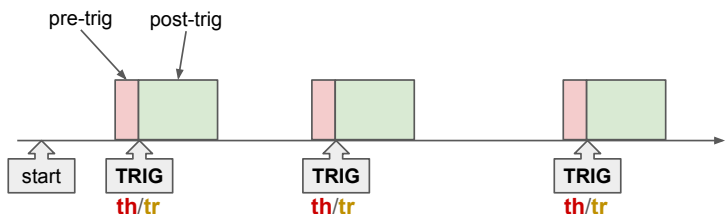

ME10 Current Transformer

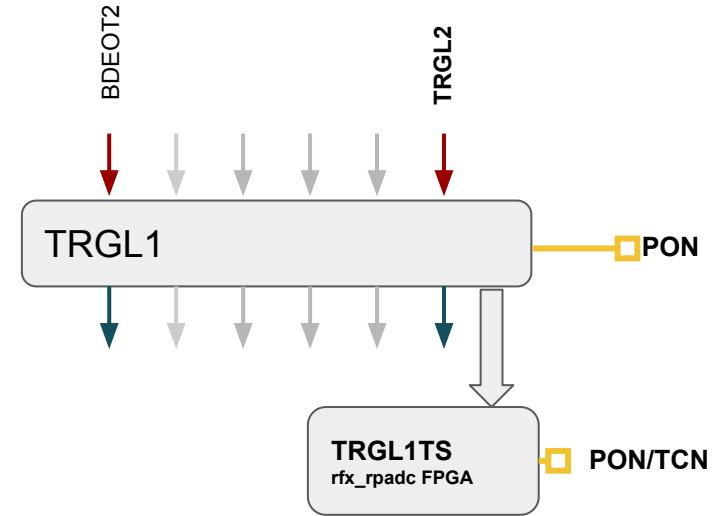
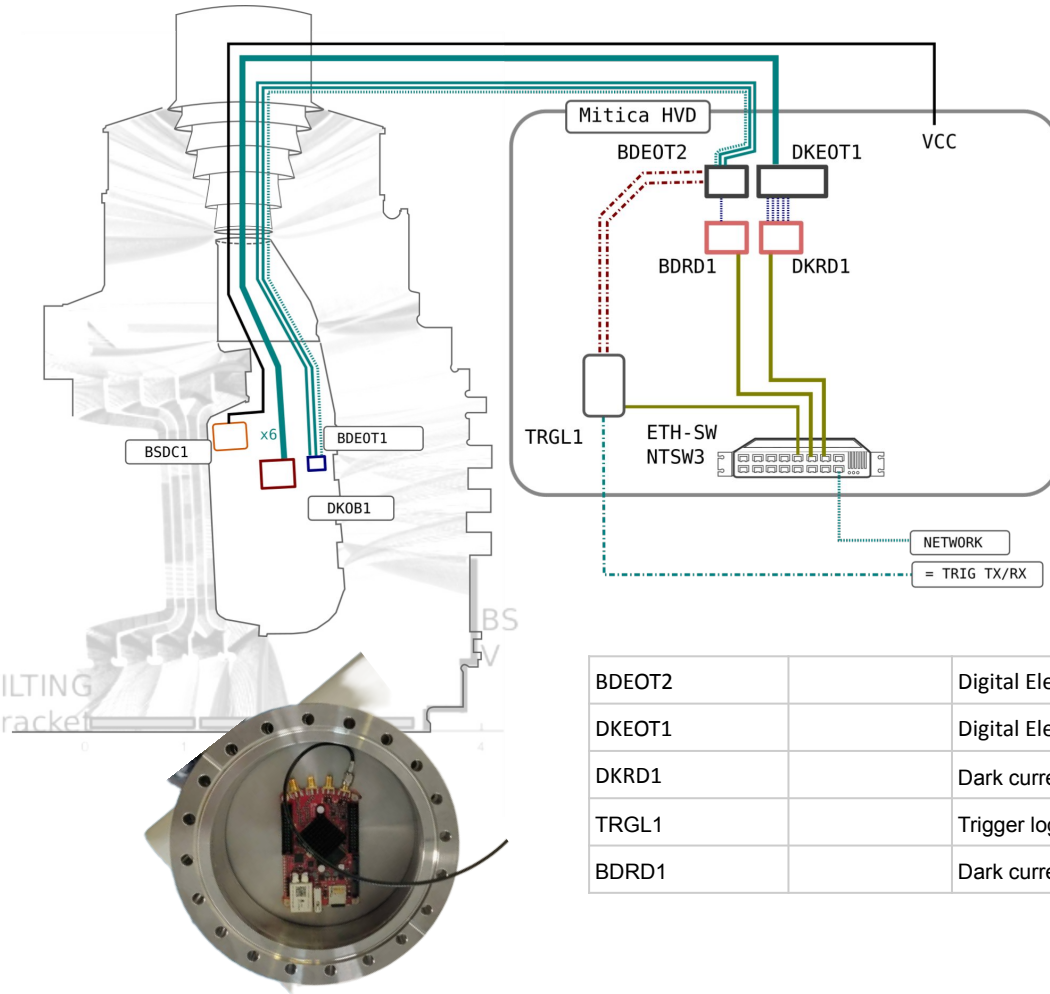

BDEOT2		Digital Electro Optical Converter	Custom component
DKEOT1		Digital Electro Optical Converter	Custom component
DKRD1		Dark current optical readout	STEMlab Redpitaya 125-14
TRGL1		Trigger logic	Custom component FPGA L8 Trigger HUB
BDRD1		Dark current COM port	Custom component FPGA readout

BSCM2 Vessel Current Diagnostics

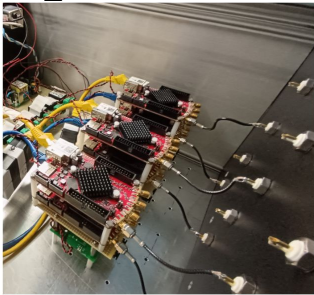
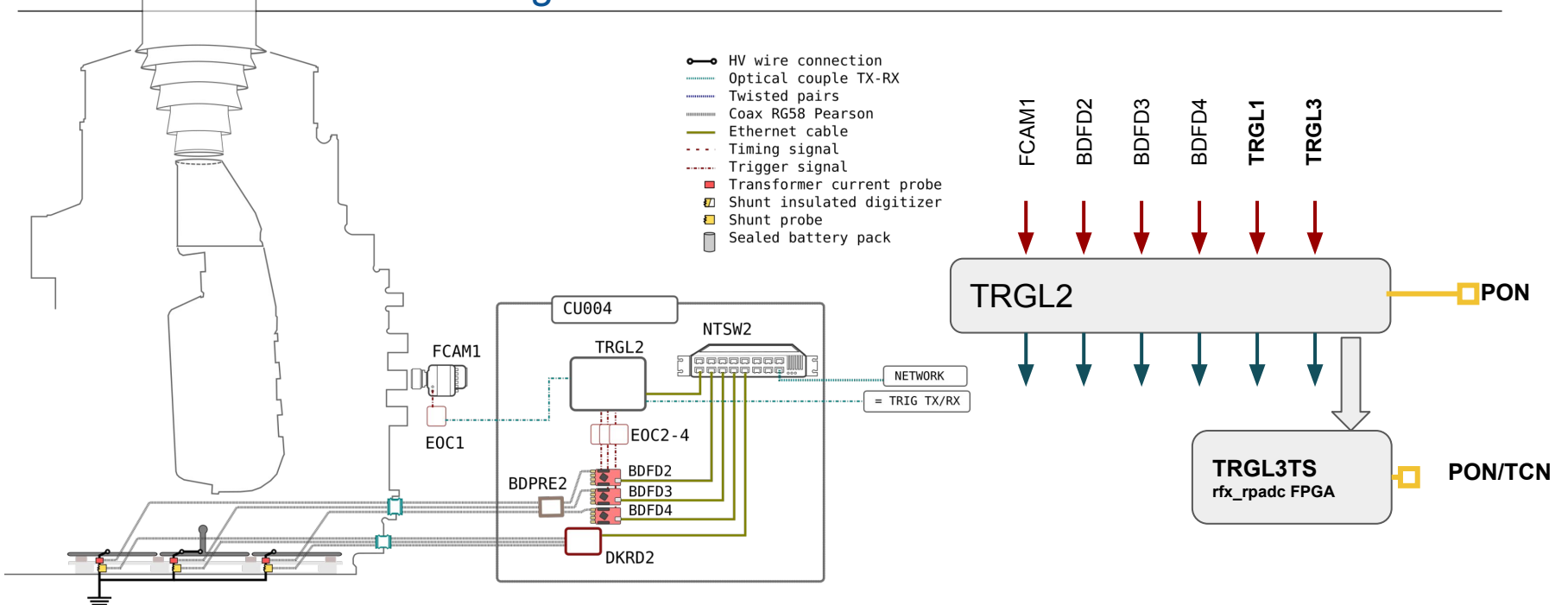

FAST CURRENT PROBES

TRGL2		Trigger logic	Custom component FPGA L8
BDFD2-4		Breakdown Fast Digitizer	3 x STEMlab Redpitaya 125-14
EOC1-4		Optical insulator	2 x Lotto boards RemTrigDev (senza ESP)
DKRD2		Dark current ADC	3 x STEMlab Redpitaya 125-14 ??
BDPRE2		Breakdown Signal Limiter Amp	

BLC - Rogowski Coils Current Diagnostics

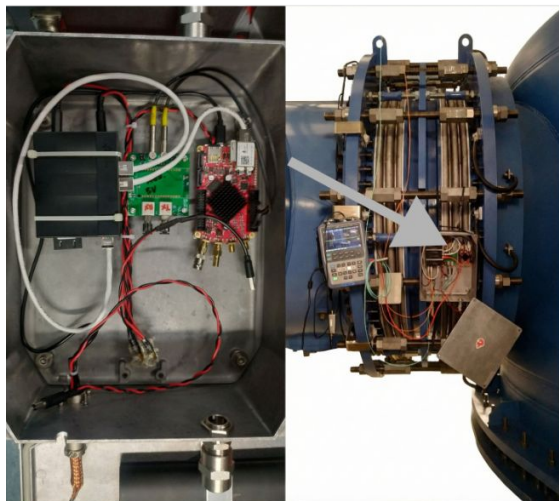
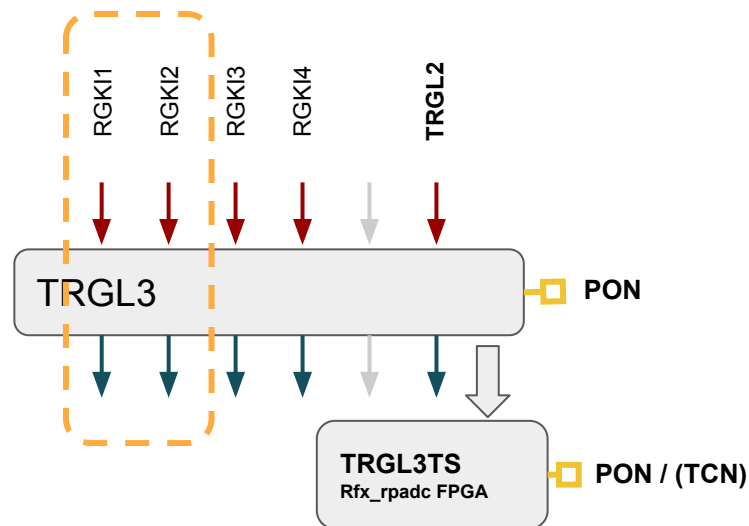
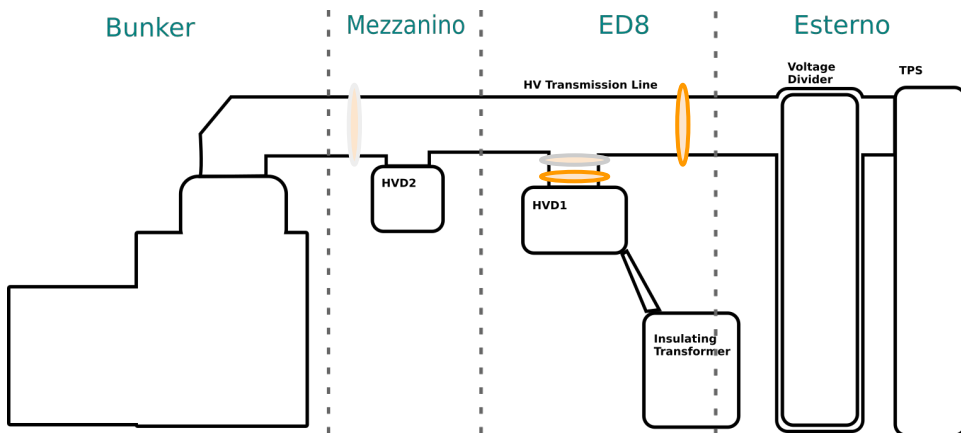

TRGL3		Custom component FPGA L8
RGK1-4	Rogowski 1-4	Custom component Sealed RP 125-14 BOX
RGKT1-4	Trigger RX/TX	Custom component L8 Trigger TX/RX Optical converter

Measuring BD events - Timing approach

Timing for a transient “short” event can be approached in two main methods:



Sync: all devices that are triggered or collect trigger have a synchronized time clock (either internal or external). Ex: NTP, PTP, WhiteRabbit

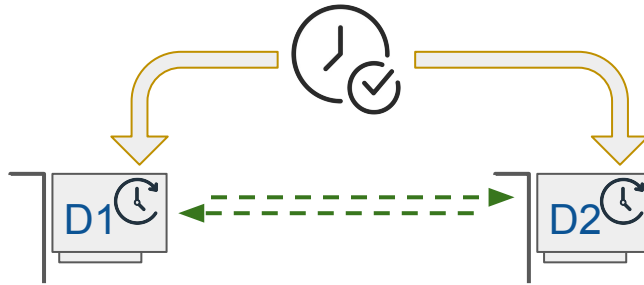

PRO:

- No need for measuring trigger delay
- Local data recorded is already timestamped

CONS:

- Needs time-aware network (1588, WR)
- Complex hardware



Async: the trigger is collected to a single time reference and adjusted with the delay of signal TOF along connecting components. The time reference is then kept in sync with the absolute time

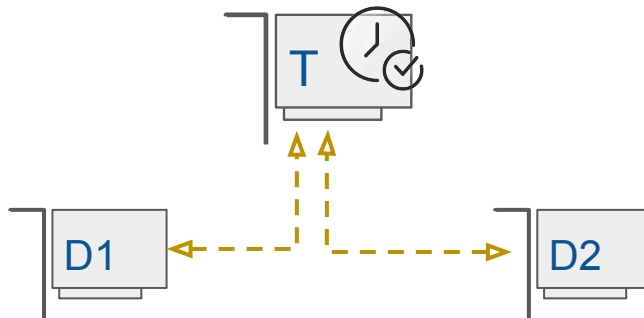

PRO:

- No need for complex hardware
- The trigger distribution could be also used as the time recorder

CONS:

- Requires time delay assessment of both device internal timing and cables
- Non self-consistent measure (complex system)

Measuring BD events - Why we went for the “hard” way

Sync {
NTP: NOT ENOUGH
PTP: fair enough but: not all components were compliant, out of stock HW IEEE-1588 PHY boards
WR: overkill, and: components not compliant and almost any capable device was out of stock

Async **Direct Link: Relative trigger acquisition on trigger HUBs**

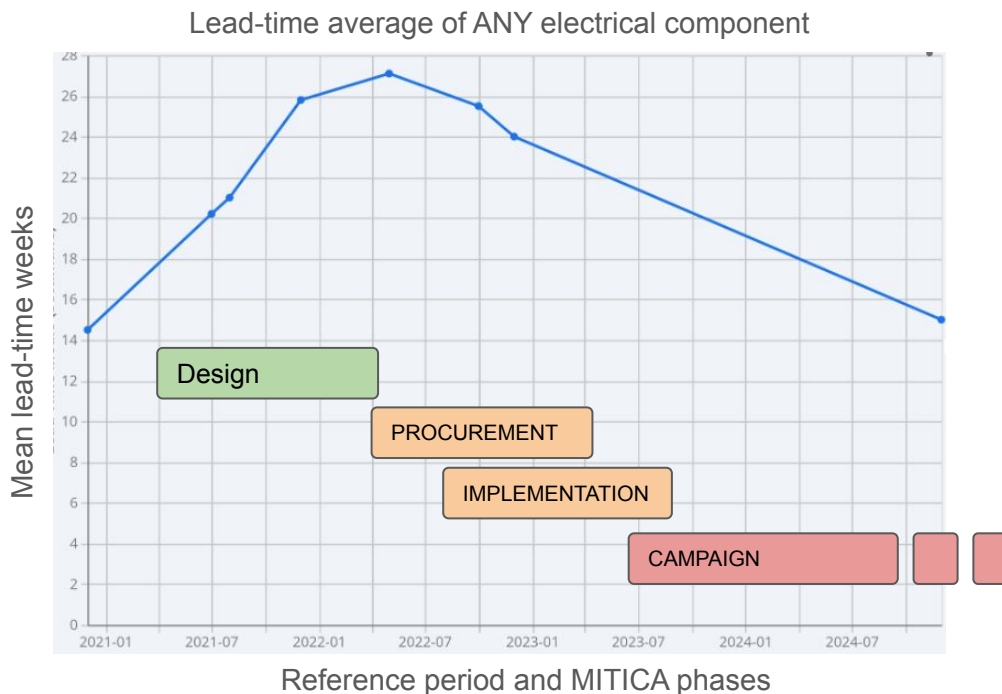

Timing HUB relative trigger time recording

The idea is to make the trigger multiplexer (responsible for the distribution of the trigger among the devices) able to measure the relative time between different trigger events.

We used the **same** Implementation of **TRANSIENT RECORDER** (*rfx_stream*) with activation threshold set to **0x0** (any active bit over threshold) so the signal recorded is **the encoded pattern of trigger envelope on each channel**.

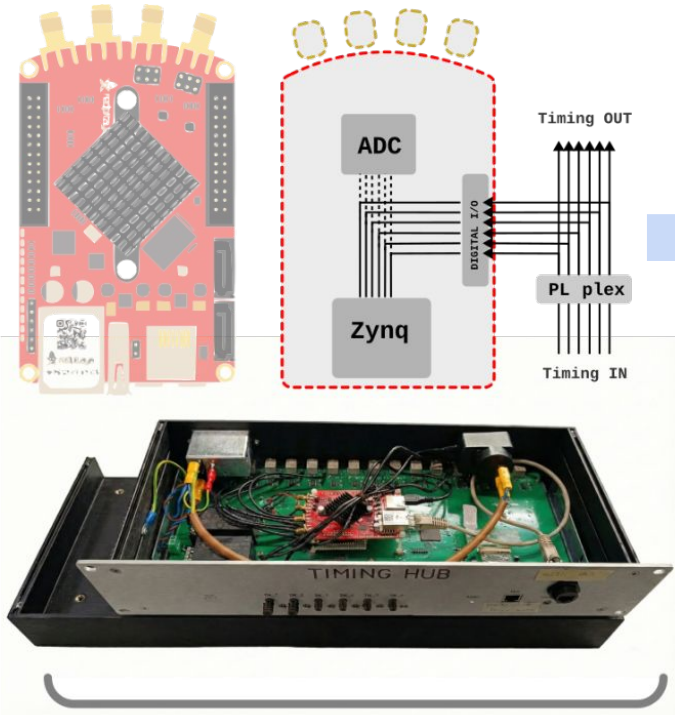

Timing HUB

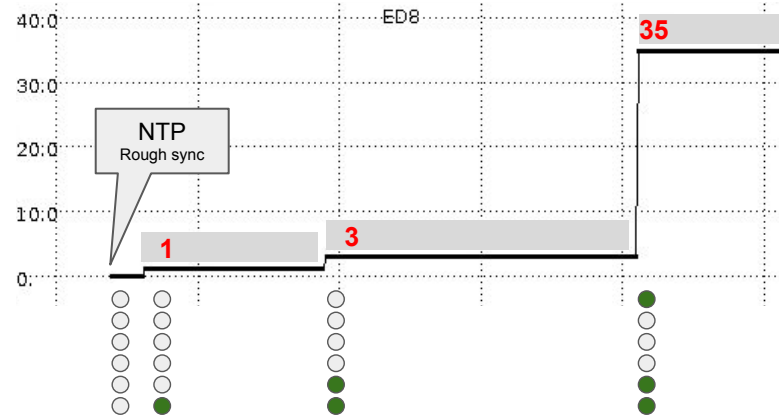

The ports relative to the acquisition of logical values coming from the ADC in a parallel bus was directly assigned to 6 input ports with LVDS logic (TMDS33 signals) through level shifters that convert the logical output of the trigger's CPLD into a differential input signal.

THE ONLY EFFORT HAS BEEN TO REROUTE THE BUS IN CONSTRAINT FILE !

Relative Trigger time from DAQ signal

```
def getTriggerRelTimes(self, trigSignal):  
    """  
    Extract relative arrival times of triggers  
    """  
    times = np.zeros(self.NUM_INPUTS, dtype=int)  
    mask = 0x0
```

```
    parentIdx = self.PARENT_PORT_ID  
    if parentIdx is not None:  
        mask = 0x1 << parentIdx
```

```
    firstTimeIdx = None
```

```
    for sample in range(len(trigSignal)):  
        # Check for new bits  
        if (trigSignal[sample] & ~mask) != 0:
```

```
            # find new flipped channels  
            newBits = trigSignal[sample] & ~mask  
            mask |= newBits
```

```
            for idx in range(self.NUM_INPUTS):
```

```
                # find which new triggers has been recorded
```

```
                if newBits & (0x1 << idx):
```

```
                    # Keep track of the index of the first received trigger
```

```
                    if firstTimeIdx is None: firstTimeIdx = sample
```

```
                    # Record time offset in ns from the first recorded trigger
```

```
                    times[idx] = (sample - firstTimeIdx) * self.SAMPLE_NS
```

```
    return times
```

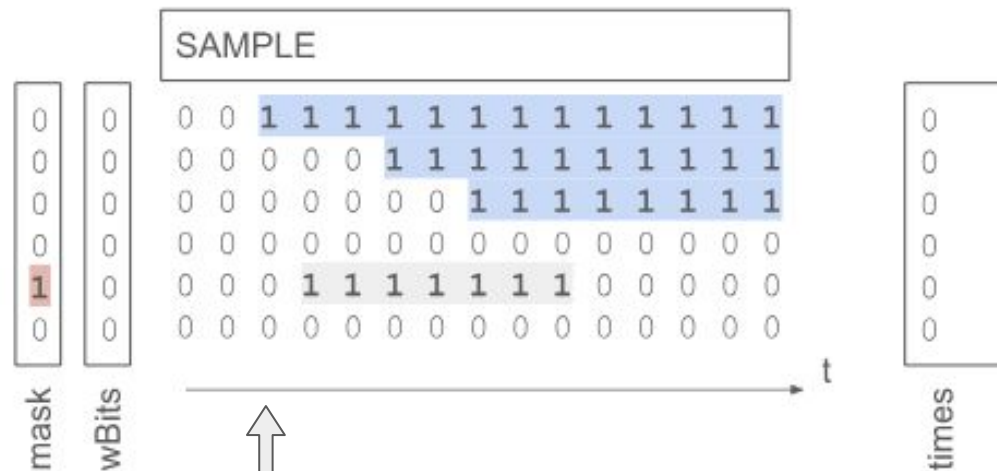

Timing HUB relative trigger time recording

The HUB records the relative time among all the trigger-out signals emitted by devices. This is not the real event time though, each trigger must be back-projected of the internal delay caused by the propagation along wires and the circuit logic.

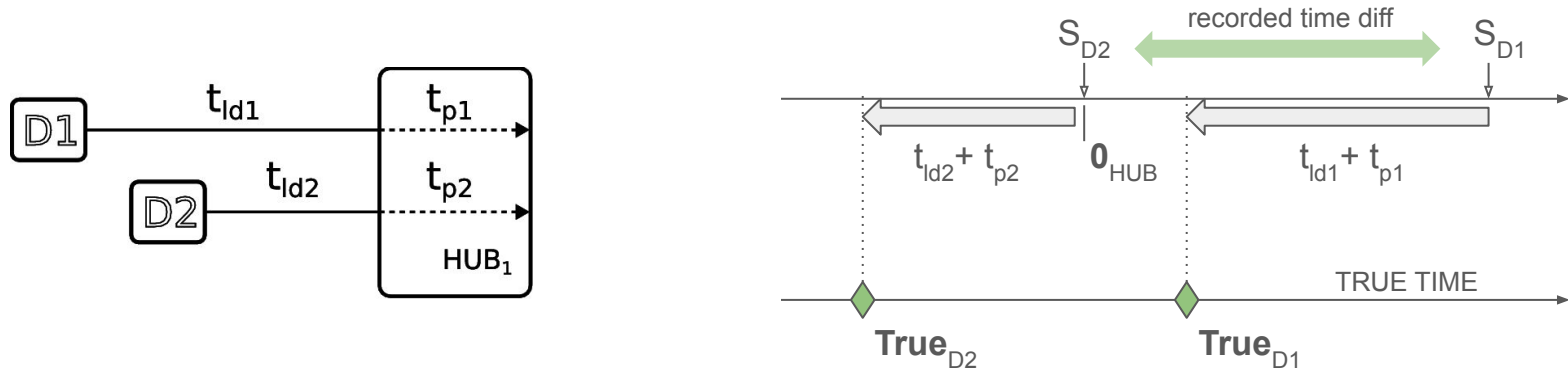

For each device:

- Trigger IN is only generating an external trigger event, it is not involved in the overall timing computation.
- Trigger OUT collects timing from device in the HUB and the total delay of the line is used to correct the recorded event.

Interconnected Timing HUBs Synchronization

Timing Hubs can be connected to others with a tree topology accounting each measured trigger of any Hub as a group of time instants, each of them measured from the time of the Hub first trigger.

Given the following assumptions:

1. A connected HUB occupy one of the IO trigger ports, but the port **does not propagate the trigger to itself**.
2. A child HUB propagates the trigger from parent but **does not count its time**, in particular because of (1) it needs to avoid using recorded time as the first trigger event (child HUB relative ZERO).

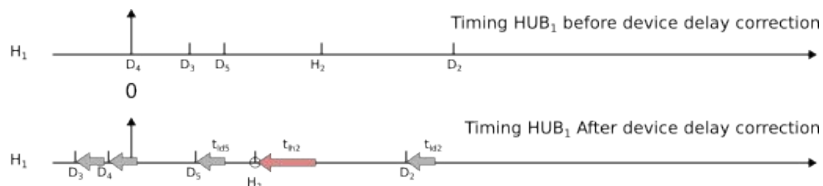
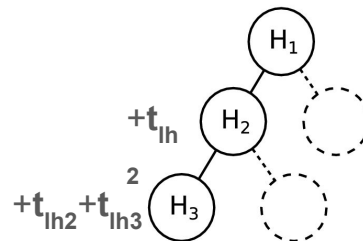
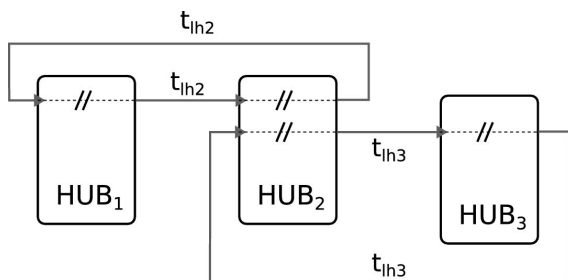

Time delay calibration

Since the FPGA in the Trigger HUB can activate output lines autonomously, it is in principle able to perform self calibration of the lines delays. The system is almost ready to perform self calibration, however for lack of time in the implementation phase in the HV test campaign we pre-computed delays manually.

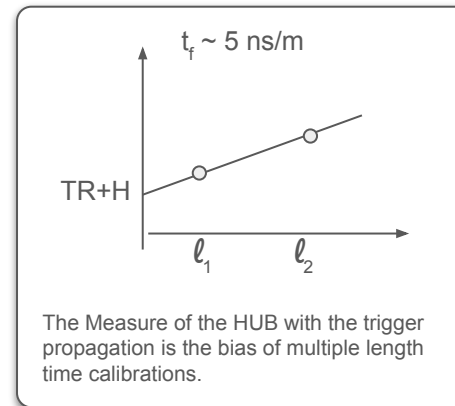
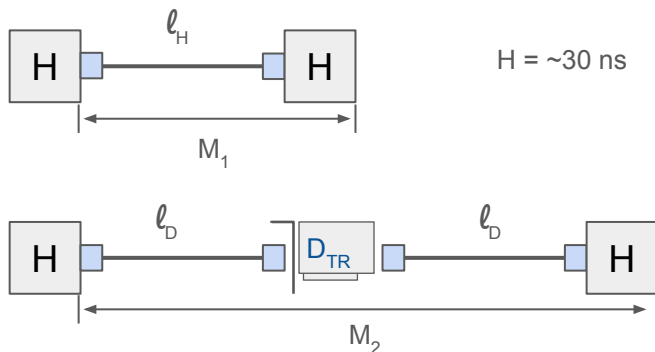

The collected parameters are assigned to a MDSplus device that carries out the synchronization of the signals.

1. Time transient device signal
2. Topology connections among Trigger HUBs
3. Channel parameters

Comment: IP:

RP Signal:

Parent Idx: Child 1 Idx: Child 2 Idx: Child 3 Idx: Child 4 Idx:

Delay: Hub Path:

In Signal Path:

Internal dynamic delay

Redpitaya transient recorder acquires signals with a trigger on signal level, but it depends on parameters:

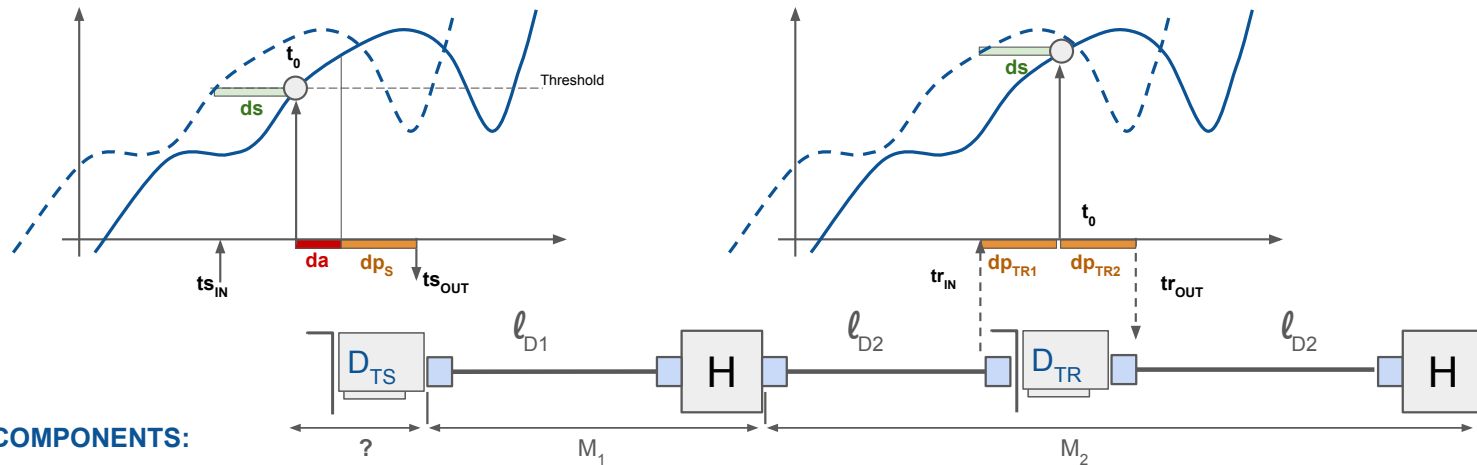

TIMING COMPONENTS:

- **ds [sensor delay]**: delay of the sensor and connection wires (from sensor to device, i.e. RG58)
- **da [activation delay]**: this is a **DYNAMIC** quantity that **DEPENDS ON PARAMETERS** (i.e. sampling freq, num samples threshold, etc.)
- **dp [propagation time]**: this depends on the internal propagation on logic (can be obtained from synthesis)

TAKE AWAY MESSAGE: An effective time aligned acquisition device must provide:

- A. THE THRESHOLD DELAY: ($da + dp_s$)
- B. For each trend sequence a flag to identify the TRIGGER SOURCE (either threshold or external)

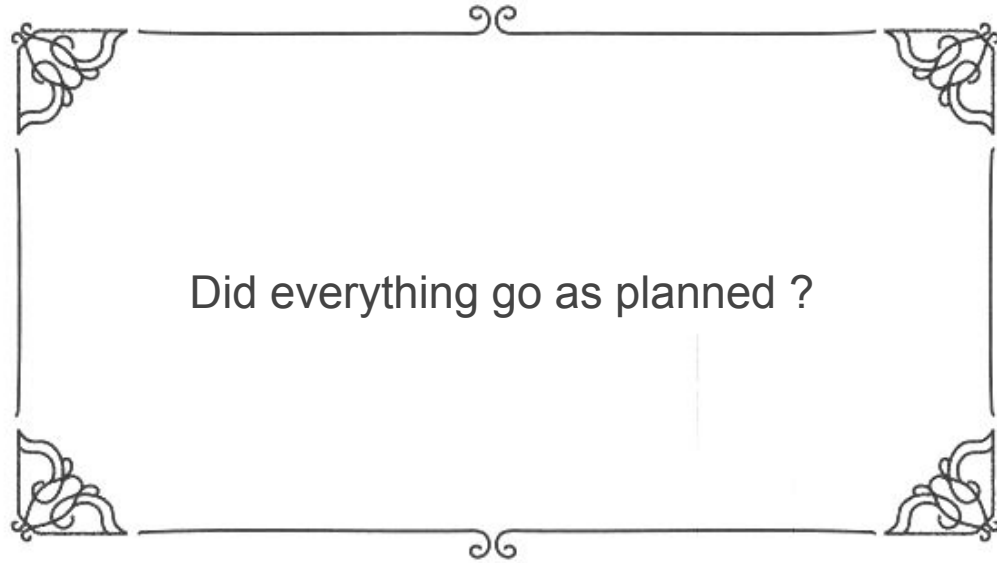

Did everything go as planned ?

Electrostatic discharge - False Trigger events generation

Even though the overall acquisition was designed for noise immunity and galvanic insulation, in the current measurement on the GP00 component (current detector towards three sections in the lower plane of the BSV), **repeated false events occurred at high voltage levels**, characterized by signals with the typical RC discharge shape.

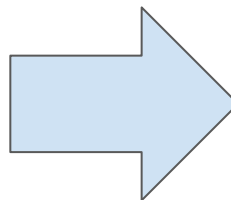
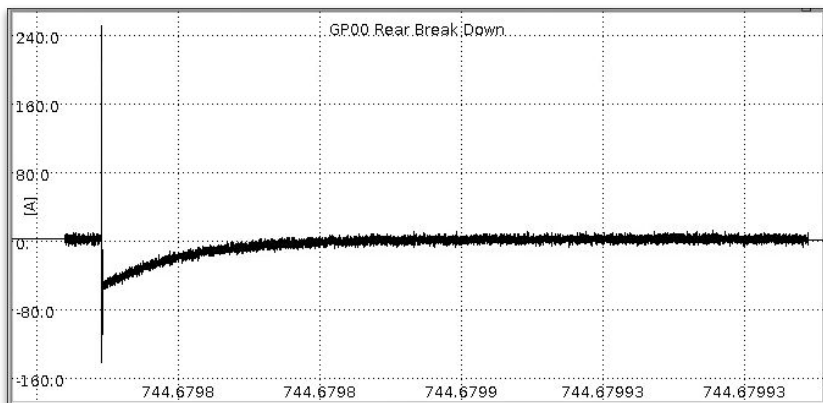

One first mitigation was to disable trigger distribution from the signals coming from GP00, although many events have been already recorded.

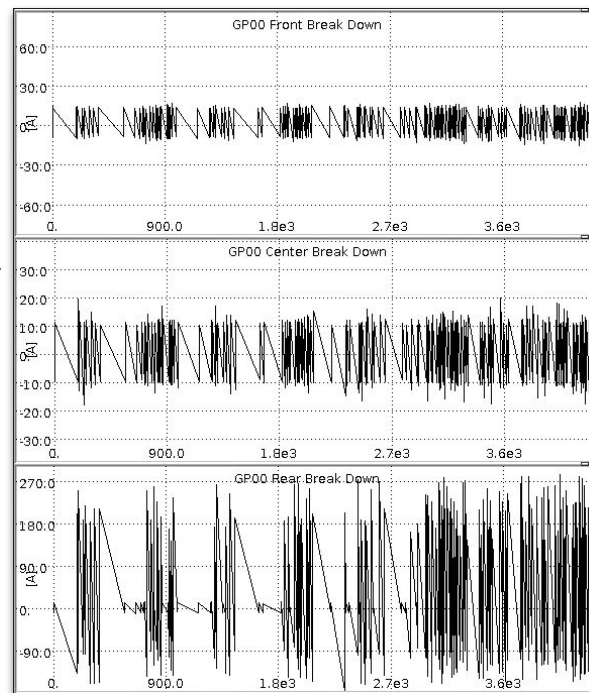

#2024071918

BD event unsupervised classification

As a clean out attempt for fake events we trained a 1D Convolutional Autoencoder (AE1DF) on signal segments from a 10K HV database. The autoencoder embeds a resampled shape into an embedded latent space of 32 dimensions.

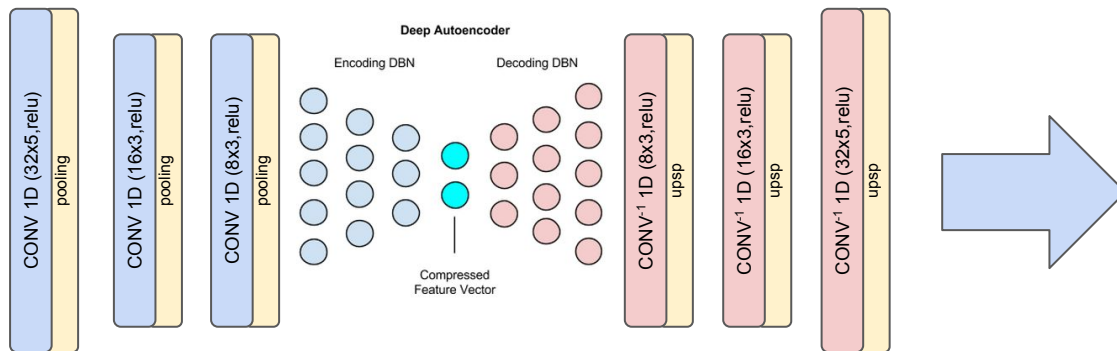

Loss Formula

The total loss is composed of two primary terms: (1) a point-wise amplitude-weighted \mathcal{L}_{amp} (MSE) and (2) a local burst energy-weighted \mathcal{L}_{energy} (MSE)

$$\mathcal{L}_{amp} = \frac{1}{N} \sum_{i=1}^N (y_i - \hat{y}_i)^2 \cdot w_i$$

$$w_i = 1.0 + 5.0 \cdot |y_i|$$

(1)

$$\mathcal{L}_{energy} = \frac{1}{N} \sum_{i=1}^N (E_i - \hat{E}_i)^2$$

$$E_i = \frac{1}{W} \sum_{j=i-W/2}^{i+W/2} y_j^2$$

(2)

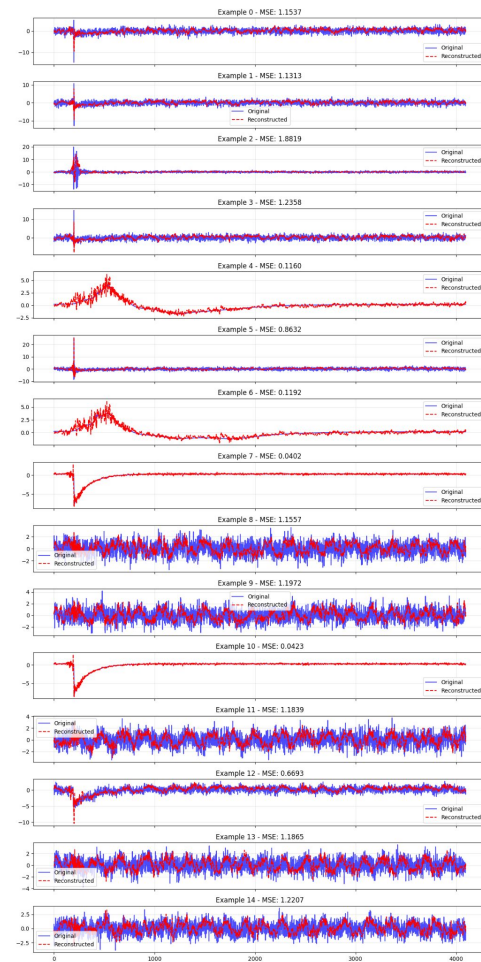

BD event unsupervised classification

Once the Autoencoder is trained we inspect an cluster the latent space defining how to group the desired clusters. This has been done using a T-SNE algorithm (with perplexity=30) passing a bidimensional space to k-means with 4 classes.

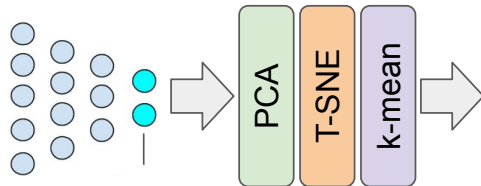
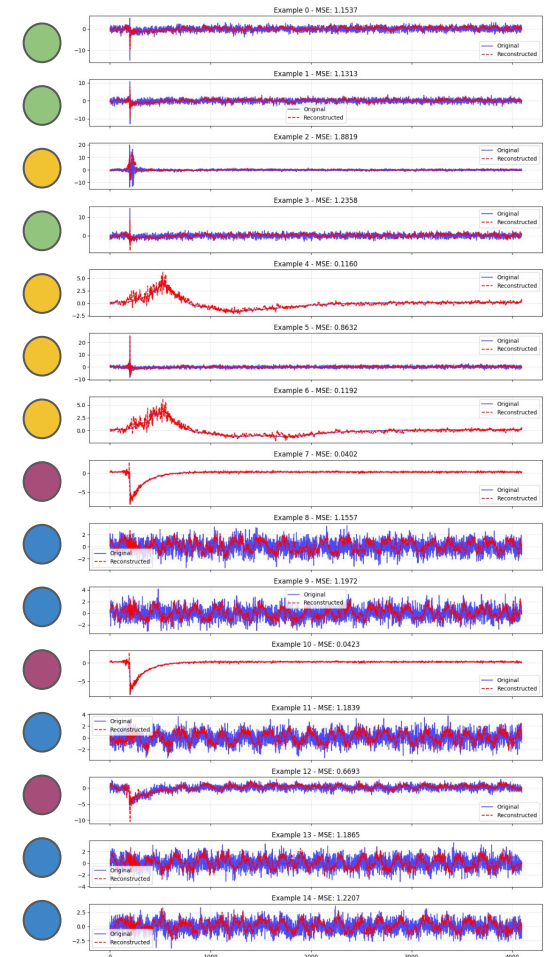
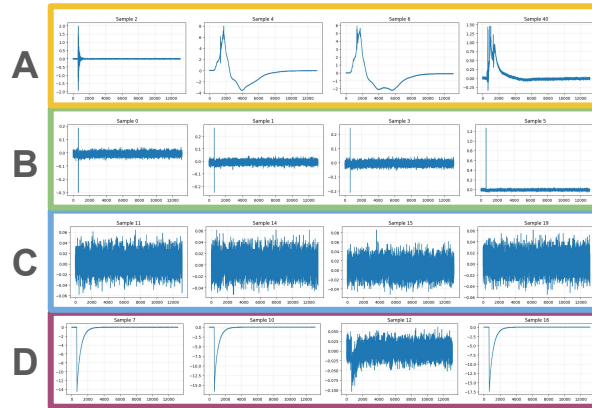
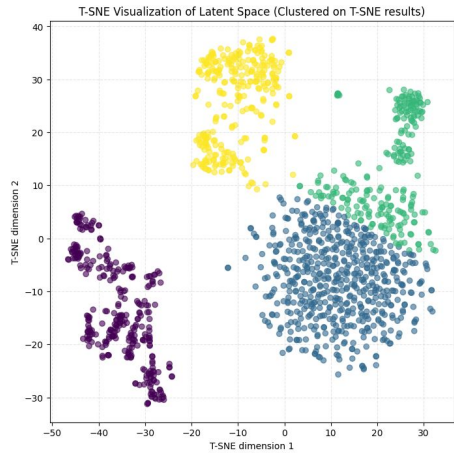

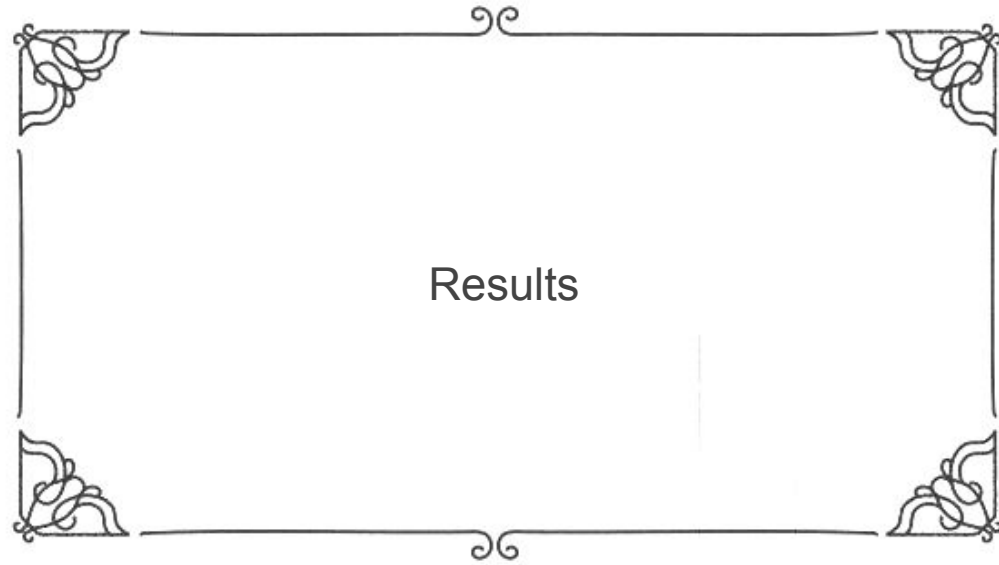

Results

Examples of successful time reconstruction of events

Once cleaned we can see two examples of the reconstructed timing showing the propagation delay of the actual arc from the internal vessel to the transmission line at the rogowski sensors.

A draft cross correlation among signal shows few nanosecond delay among the plates of the GP00 and **1.5** microseconds delay from the GP00 and the Rogowski coils. This result is partially unexpected and is probably caused by the core-snubber component (a 5 m length magnetic core concatenated with the line) that is introducing a delay 3x higher than the sole line model.

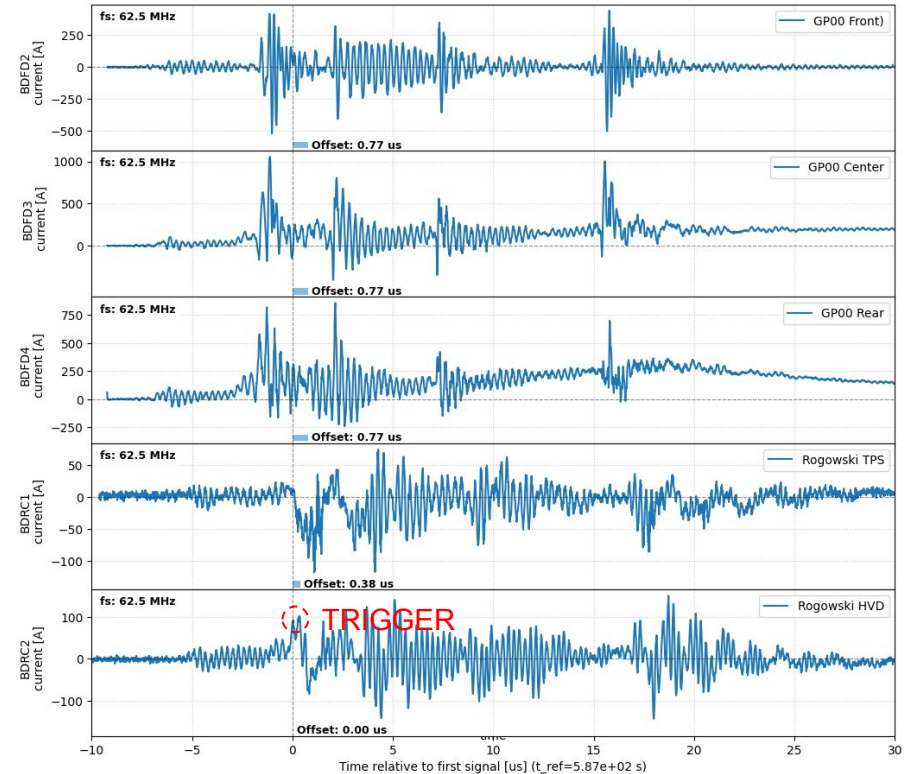
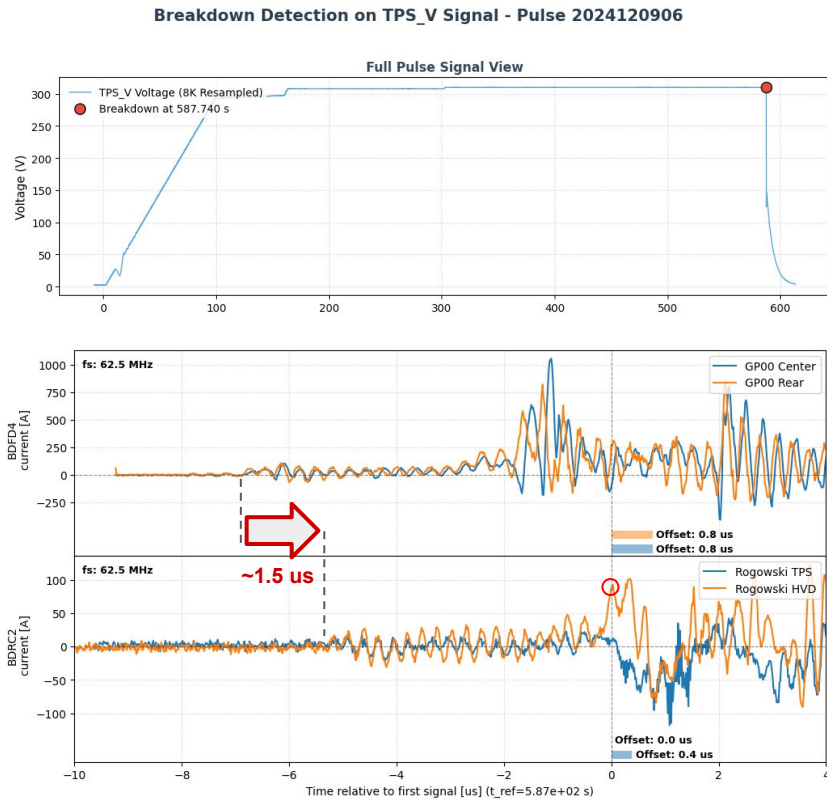

Examples of successful time reconstruction of events

A draft cross correlation shows **1.5** microseconds delay from the GP00 and the Rogowski coils.

The actual knowledge of the TOF in the trigger propagation allows to compensate the delay among signals and look for a fake “local” system where all waveforms overlap each other, suitable for Fourier analysis.

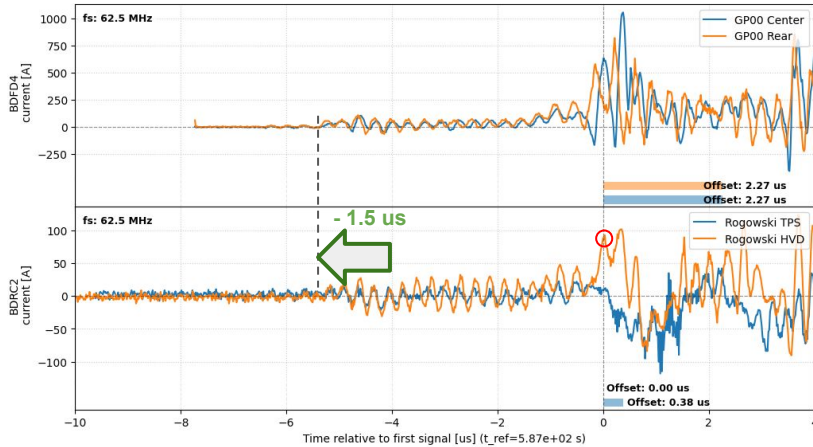

A stable HF oscillation at ~3.5 MHz appears before the BD providing a possible observable precursor (4 us ahead).

#2024120906

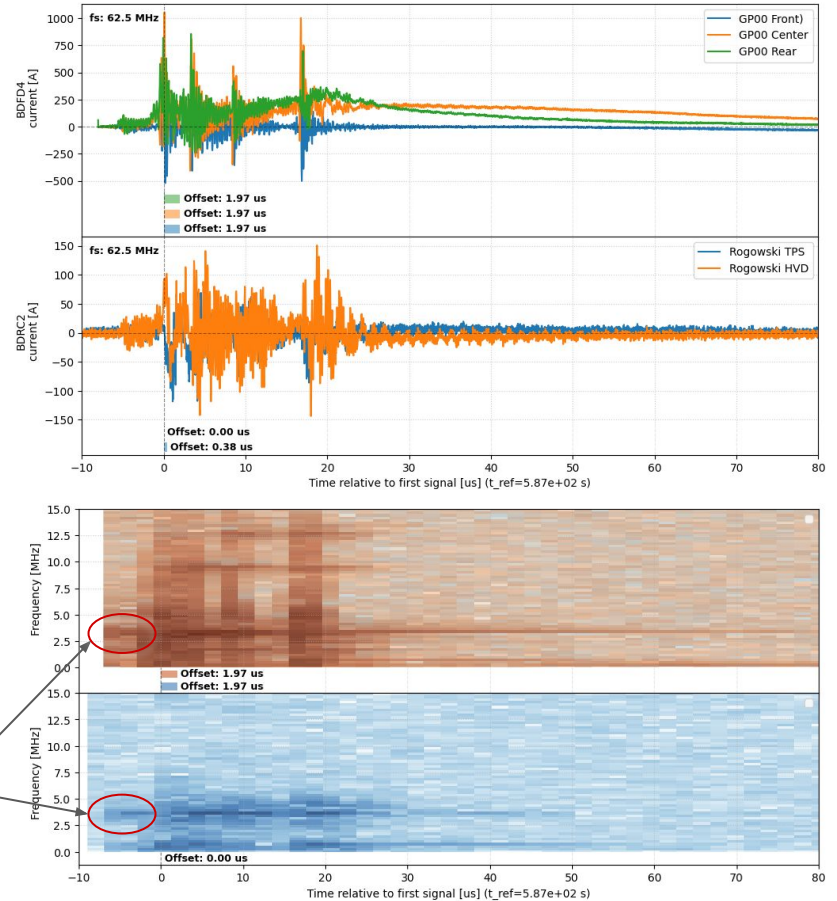

Examples of successful time reconstruction of events

The trigger distribution has been able to effectively trigger events that were under the threshold for many devices

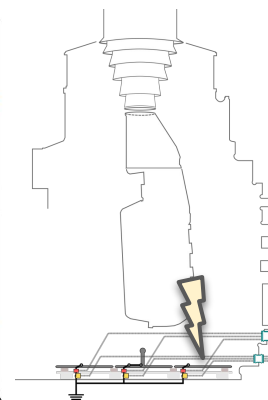
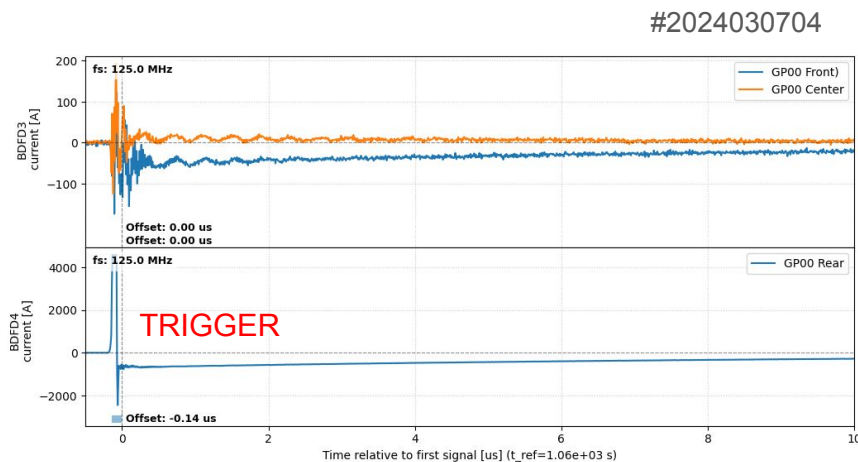
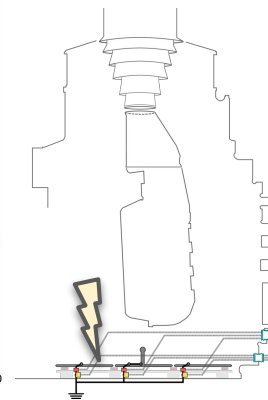
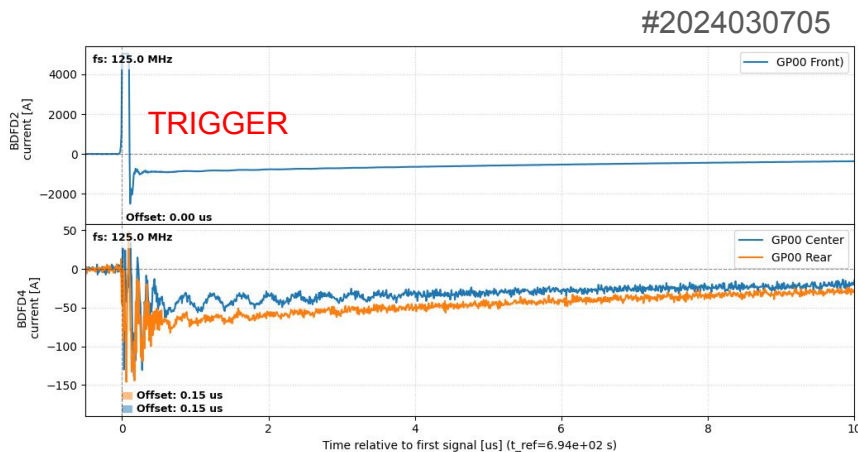
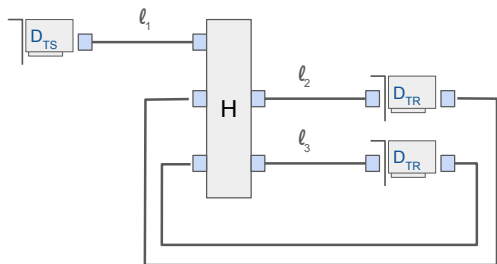

Examples of successful time reconstruction of events

Once cleaned we can see two examples of the reconstructed timing showing the propagation delay of the actual arc from the internal vessel to the transmission line at the rogowski sensors.

A draft cross correlation among signal shows few nanosecond delay from the plates of the GP00 and one microsecond delay in the Rogowski.

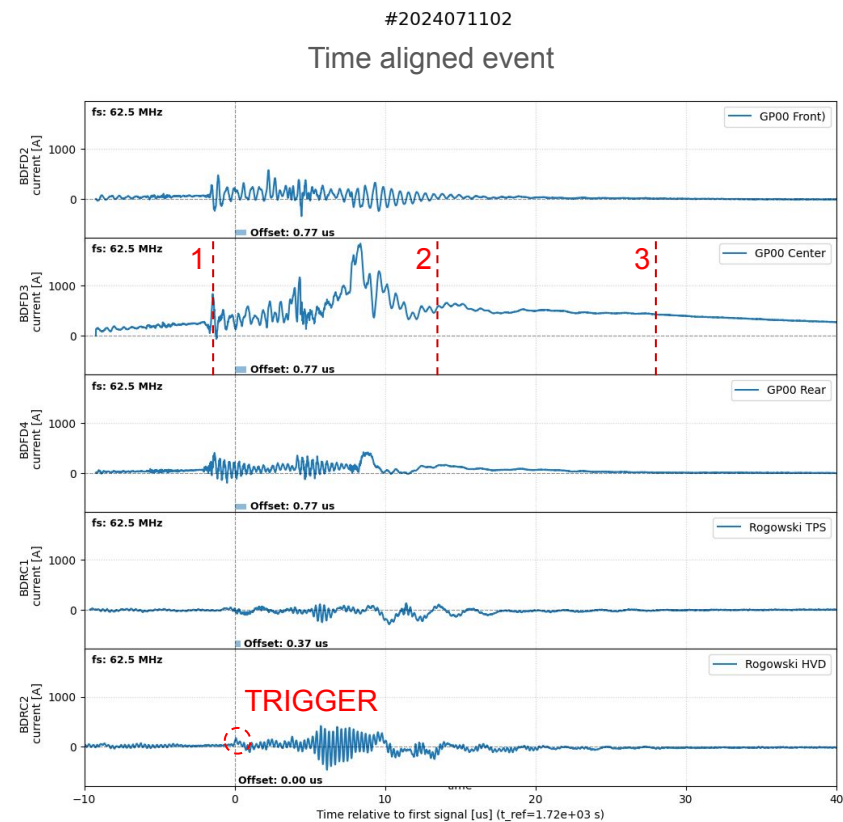
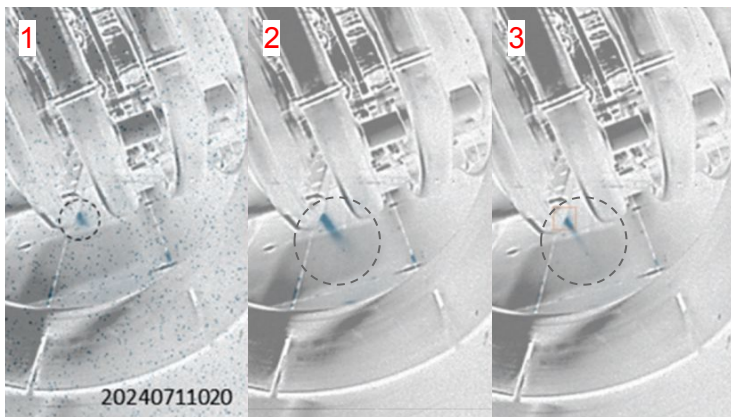
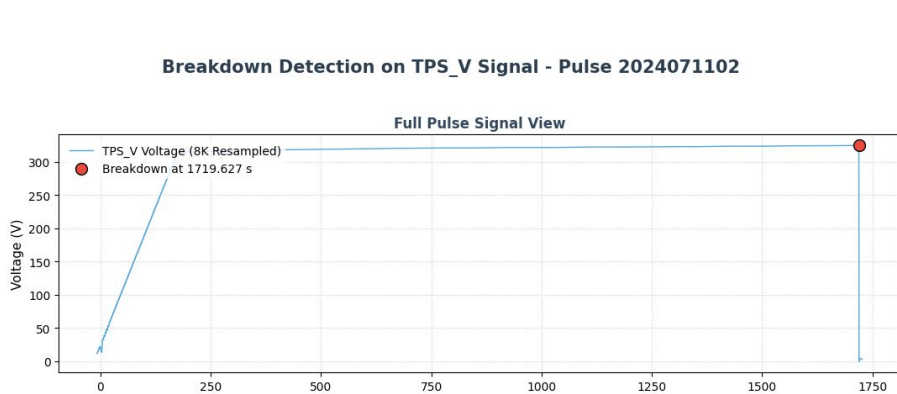

Conclusions

This contribution reported a successful attempt to build a simple precise timing reconstruction system relating breakdown event in MITICA HV test campaign.

We proved that, by a simple change of few lines of codes, we can turn a transient recorder into a sub microsecond time reconstruction device, without need for clock distribution and synchronization.

This has been possible thanks to the ingenuity and synergy among researchers and technicians that faced hard environmental constraints with new ideas and custom solutions.

Thanks for your kind attention!