

# Design and Evaluation of DAQ Architectures for Prompt-Gamma Timing in Particle Therapy

**Mas Milian, F.;** Data, E. M.; Cerello, P.; Fernandez Moreira, M. D.; Ferrero, V.; Mereghetti, A.; Montalvan, D.; Pennazio, F.; Pullia, M. G.; Ranjbar, S.; Rivas Ortiz, I. B.; Sacchi, R.; Vignati, A.; Fiorina, E.; Giordanengo, S.

INFN, Turin division, Turin, Italy

UNITO, University of Turin, Physics Department, Turin, Italy

CNAO, Centro Nazionale di Adroterapia Oncologica, Pavia, Italy.

UESC, State University of Santa Cruz, DEC, BA, Brazil,

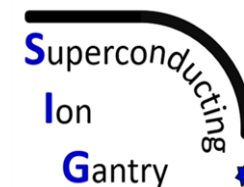

\* [fmasmilian@gmail.com](mailto:fmasmilian@gmail.com), [masmilia@to.infn.it](mailto:masmilia@to.infn.it)

## SUMMARY

- Introduction
- DAQ1: CAEN DT5742 digitizer-based system
- DAQ2: CERN PicoTDC-based system
- DAQ3: CAEN DT5203-based system with analog inputs
- Current status. DAQ4: CAEN DT5203-based architecture with 64 digital LVDS inputs
- Conclusions

# Introduction

## Principles of Prompt-Gamma Timing for Range Verification

- Shift in the Bragg peak position can modify the dose delivered to the tumor and to healthy tissues.
- **PGT is a technique for in vivo and in beam, range monitoring** based on the time correlation between the primary particles and the PG produced by nuclear interactions.
- Because PG are emitted on a **sub-nanosecond timescale** their TOF distributions contain information about the beam path and interaction profile.
- **Does not require mechanical collimation.**

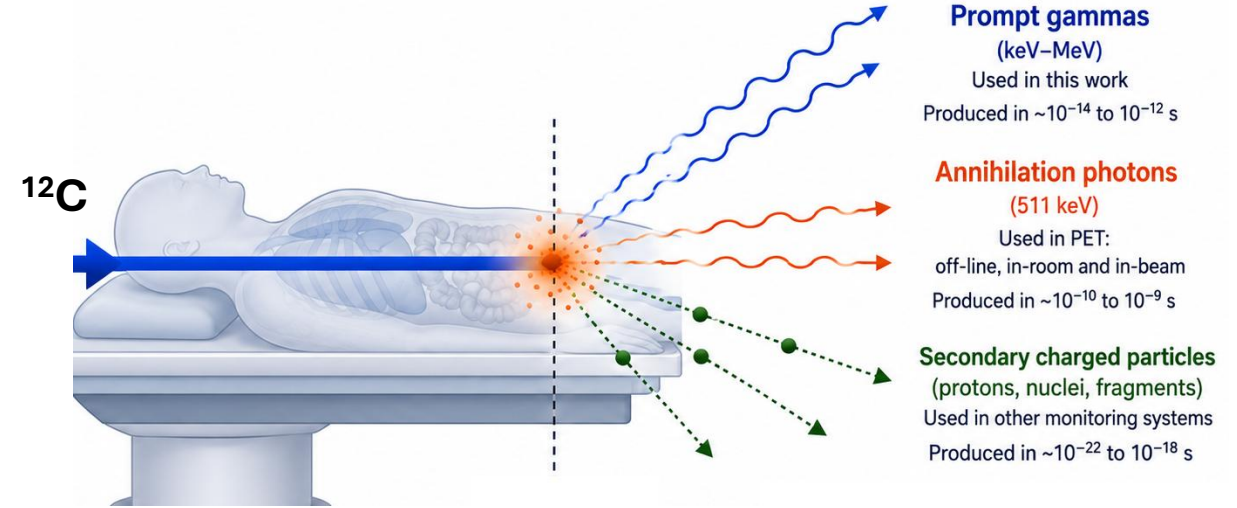
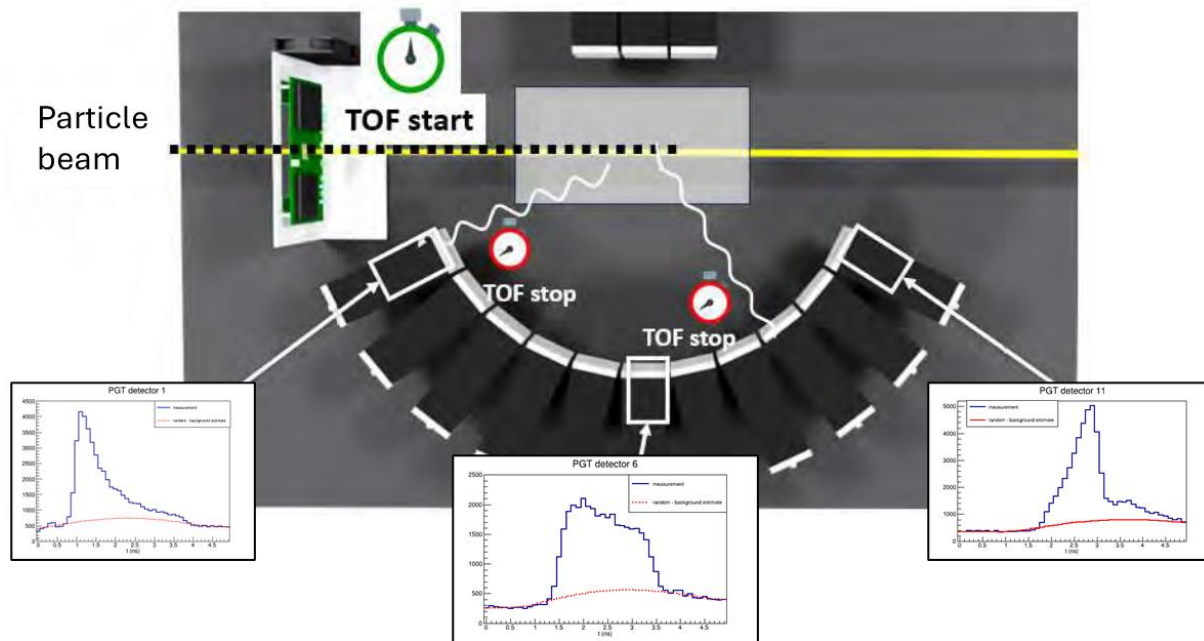

## Spatiotemporal Emission Reconstruction MLEM-based solution

<https://doi.org/10.1088/1361-6560/ac5765>

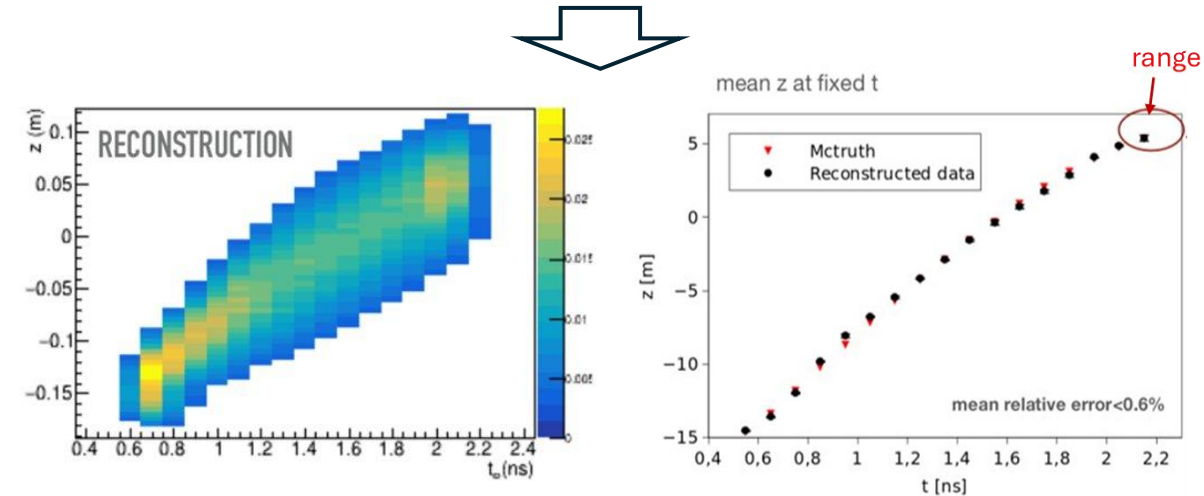

Courtesy of F. Pennazio, V. Ferrero and E. Fiorina.

## Final Goal: A Fully Integrated System for Dose Delivery and Range Verification in Particle Therapy

### System specifications

- The target system must operate at clinical rates and provide precise time-of-arrival measurements
- **Primary-particle:** timing resolution below **100 ps**, at rates up to  **$10^8 \text{ cm}^{-2} \text{ s}^{-1}$** .
- **Prompt-gamma:** gamma energies above **511 keV**, with **<100 ps** timing resolution at rates up to  **$10^5 \text{ events/s}$** .
- **Synchronized primary-gamma TOF** calculation within a **tens-of-nanoseconds** detection window.
- Acquisition-chain validation using dedicated reconstruction models.

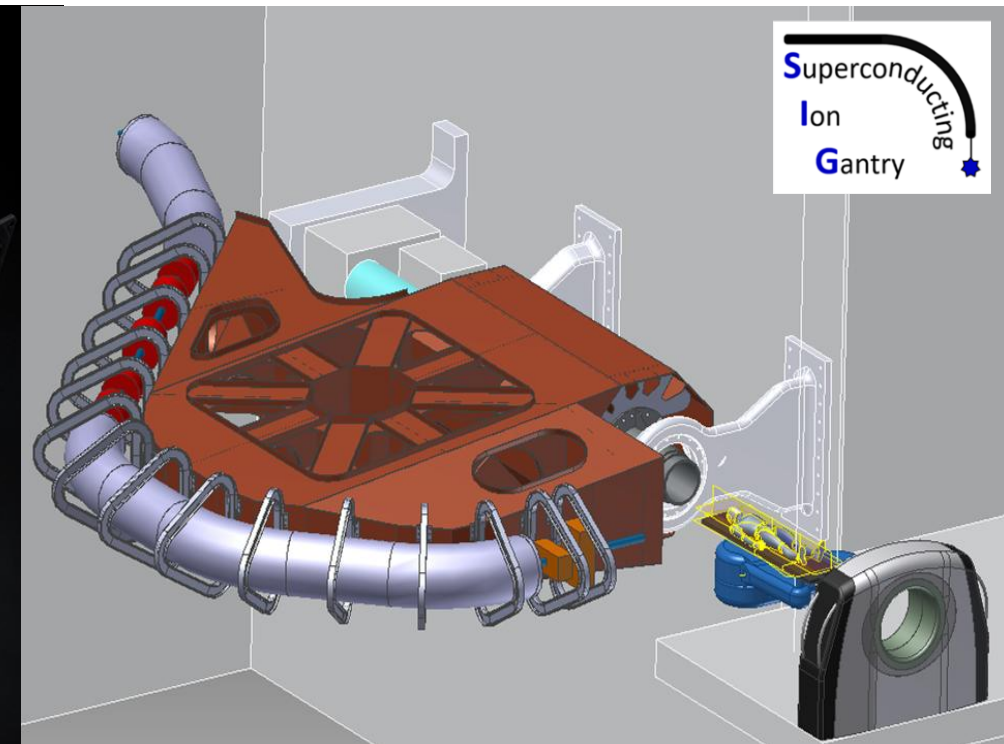
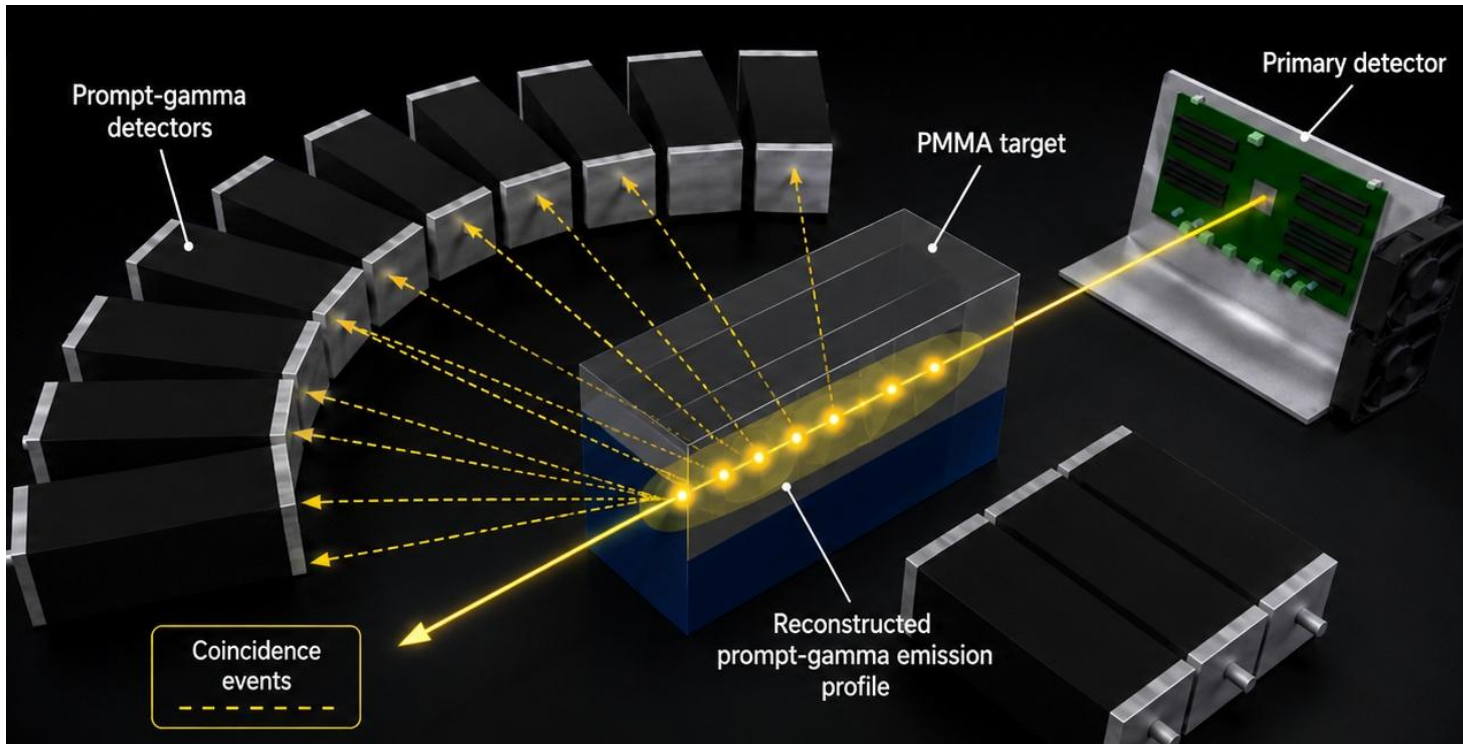

# DAQ1: CAEN DT5742 digitizer-based system

DAQ1, was based on the **CAEN DT5742** Digitizer

## Primary detector

### LGAD Detector

- **Single particle** detection. **Fast signals:  $\sim 2$  ns**
- Operated with gain for protons and without gain for carbon ions
- 11 strips, each with an active area of  $2.2 \text{ mm}^2$
- **Readout 8-channels amplifier board**
- **Time resolution:  $\sim 60$  ps** ( $140$  ps FWHM)

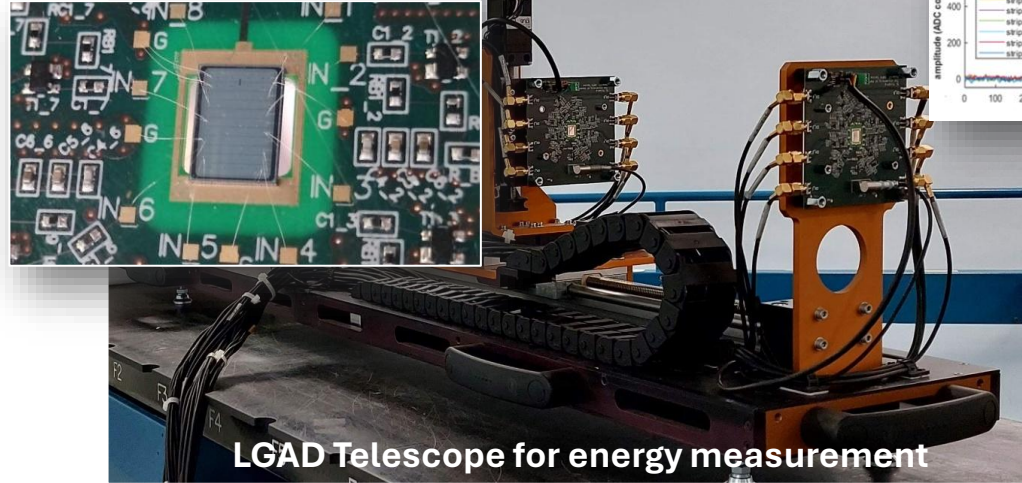

LGAD Telescope for energy measurement

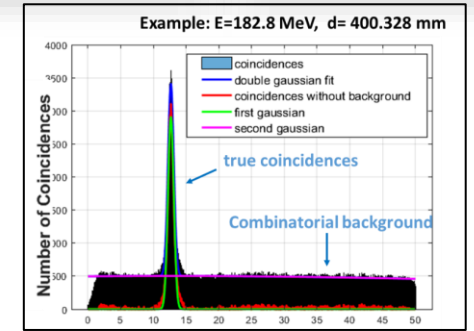
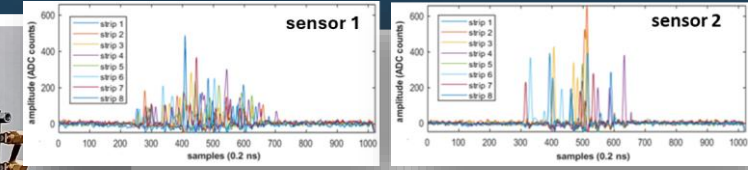

<https://doi.org/10.3389/fsens.2025.1654578>

## Secondary detector

### LaBr<sub>3</sub>:Ce coupler to a PMT

- Crystal size:  $3.81 \text{ cm} \times 3.81 \text{ cm}$
- Signal duration:  $\sim 300$  ns
- **Timing resolution:  $\sim 120$  ps** ( $\sim 283$  ps FWHM)

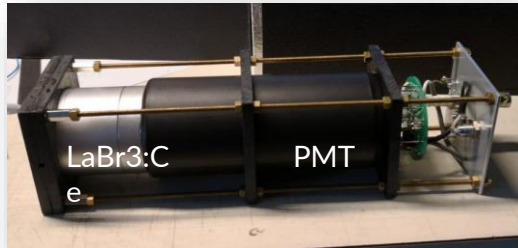

## CAEN DT5742 DAQ System

- **8 primary channels** and **2 secondary channels**
- **sampling rate of 2.5 GS/s**
- **Self-triggered on secondary channels**
- **Threshold above the 511 keV annihilation peak**
- $\sim 400$  ns waveform window
- $\sim 2.5$  kHz average trigger rate
- **TOA extracted offline using CF applied to digitized waveforms**

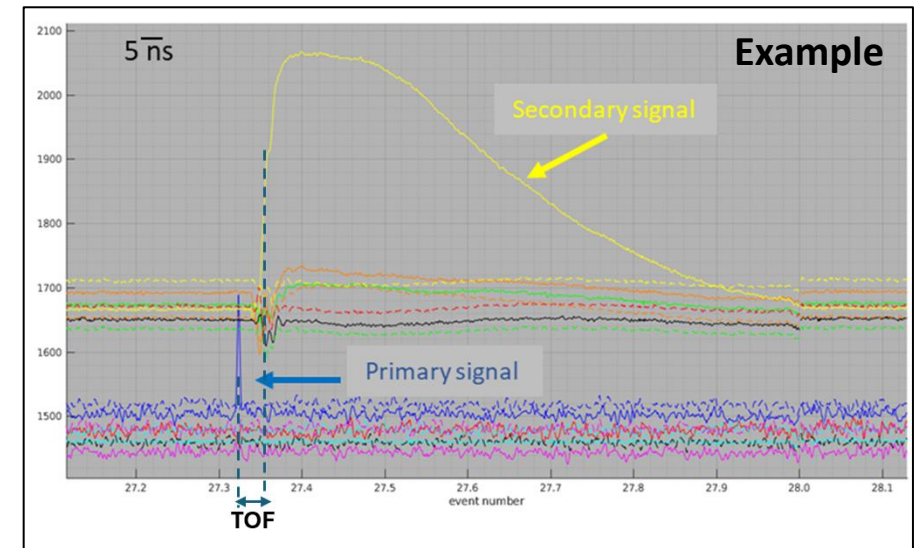

This architecture provided good timing performance, but the maximum duty cycle was only about **0.4%**.

# DAQ1: CAEN DT5742 digitizer-based system

## Experimental Tests at CNAO (Italy)

- Sub-clinical beam intensity
- **227 MeV protons ( $\sim 10^7$  p/s)** and **399 MeV/u carbon ions ( $\sim 10^6$  p/s)**

Comparison between:

- **Homogeneous PMMA target ( $15 \times 15 \times 20 \text{ cm}^3$ )**
- **PMMA target with a 4 cm air cavity**

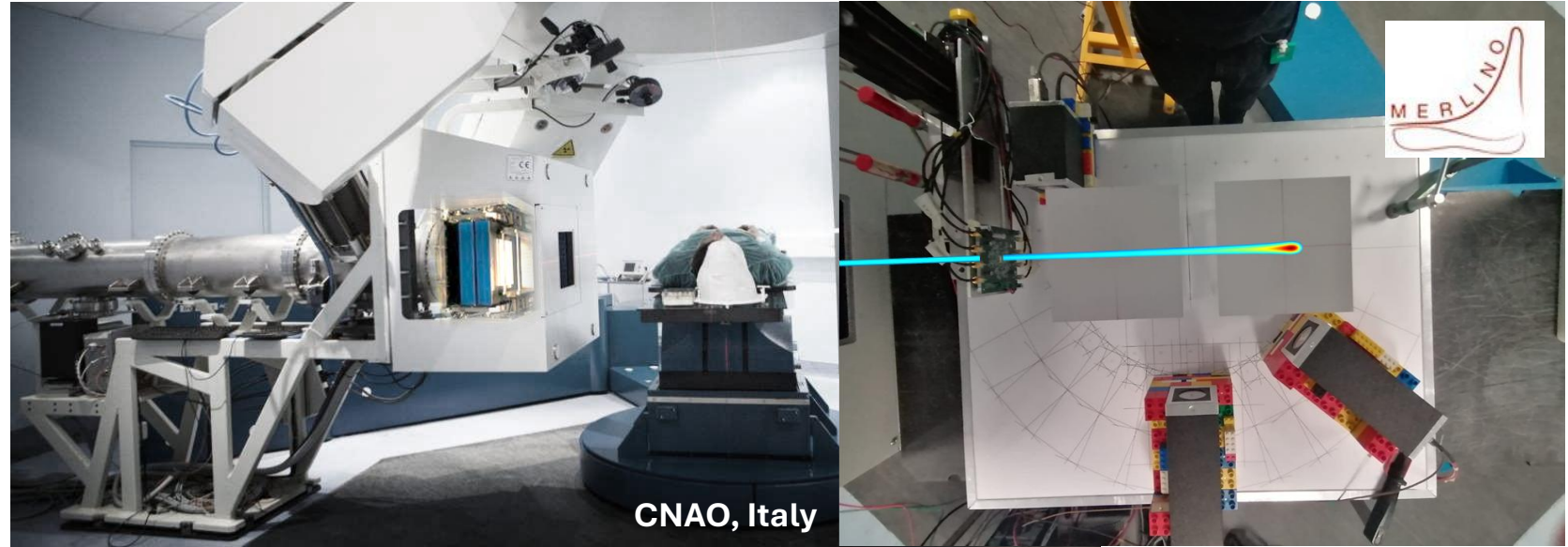

## Results

- **Air gaps broadened the distributions due to increased particle range.**
- Distributions were normalized to the air-gap-independent initial region.
- **Reduced prompt-gamma production was observed inside the air gap.**
- **Results were consistent with the expected range shift.**

### PGT TOF distribution

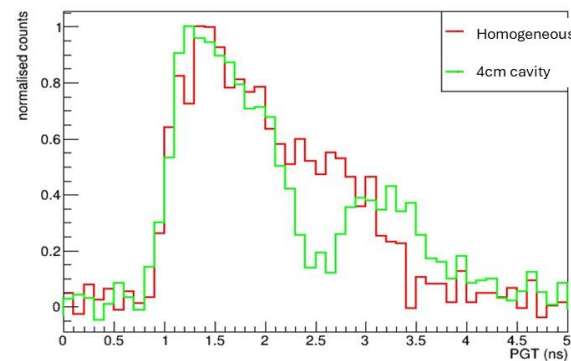

Protons

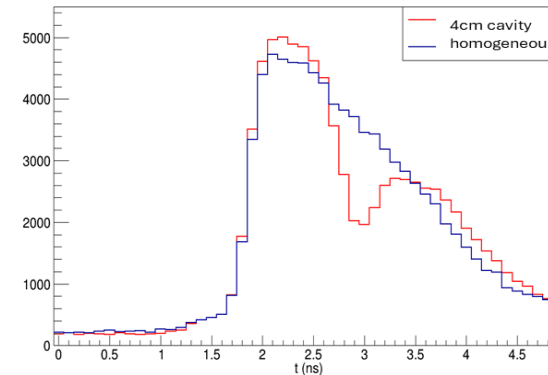

Carbon ions

### Proton range difference

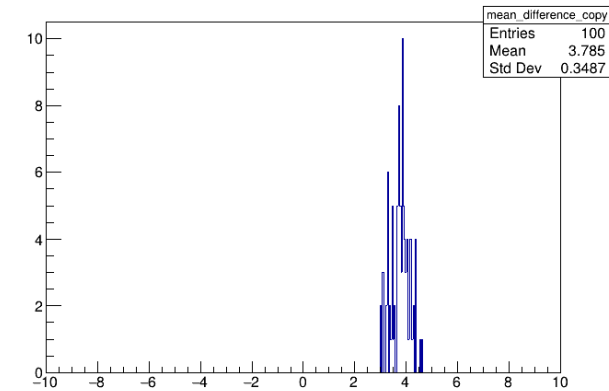

$3.8 \pm 0.3 \text{ cm}$ , no outliers.

<https://doi.org/10.48550/arXiv.2511.21344>

**Demonstrated that prompt-gamma timing is sensitive to changes in the beam path.**



## Positive outcomes

- **Accurate TOA** extraction from **primary** and **secondary** analog signals.
- Operation at average carbon-ion rates of  $10^6$  particles/s (sub clinical)
- **Simultaneous acquisition** of primary and secondary detector signals.
- 511 keV gamma events filtered using energy thresholds.

## Limitations

- **Low duty cycle** (~0.4%) and **long acquisition times** (tens of minutes).
- Limited scalability due to the use of only **8 primary channels**.

**DAQ1 was useful for proof-of-concept studies, but it was not scalable enough for clinical-rate operation**

# DAQ2: CERN PicoTDC-based system

DAQ2 was developed using the **CERN PicoTDC**

## Primary Detector Upgrade

- **ESA-ABACUS** particle-counting system
- **LGAD**, fast digital LVDS pulses  $\sim 2$  ns for single-particle
- **6 ABACUS ASICs**, 144 channels
- **Improved duty cycle. Dead time:  $\sim 10$  ns**
- **Detection efficiency:  $\sim 50\%$  for protons and  $\sim 90\%$  for carbon ions**

## ABACUS ASIC ( $\times 6$ )

- 110 nm CMOS technology
- 24 channels per ASIC (144 channels total)
- CSA dynamic range: **4–150 fC**

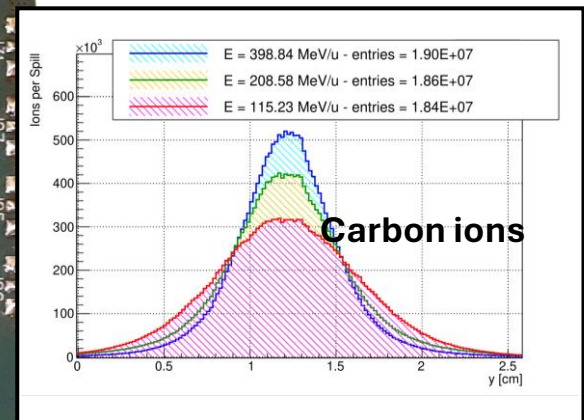
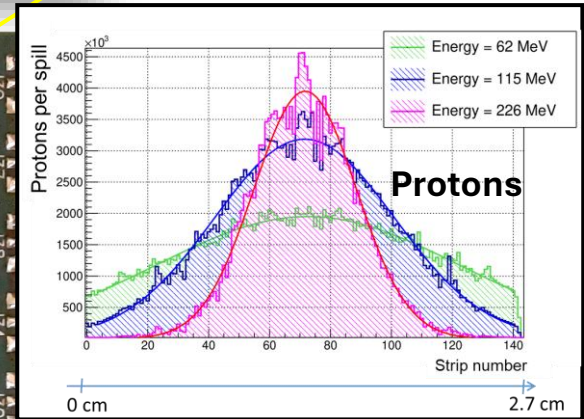
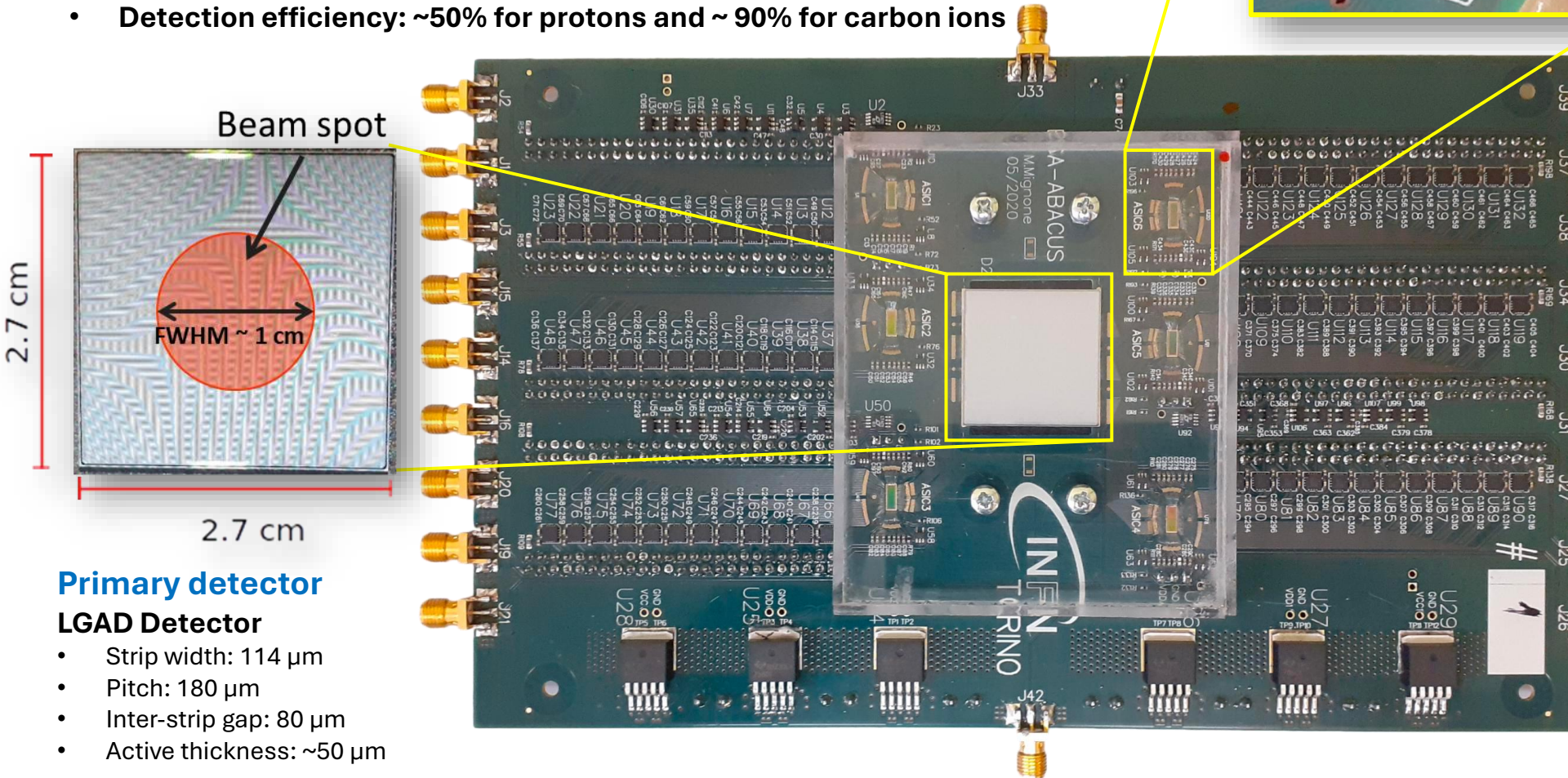
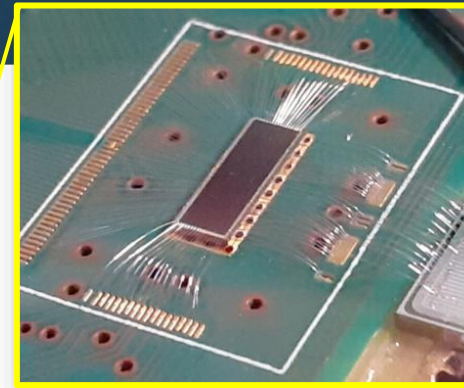

<https://doi.org/10.1016/j.nima.2025.170712>

# DAQ2: CERN PicoTDC-based system

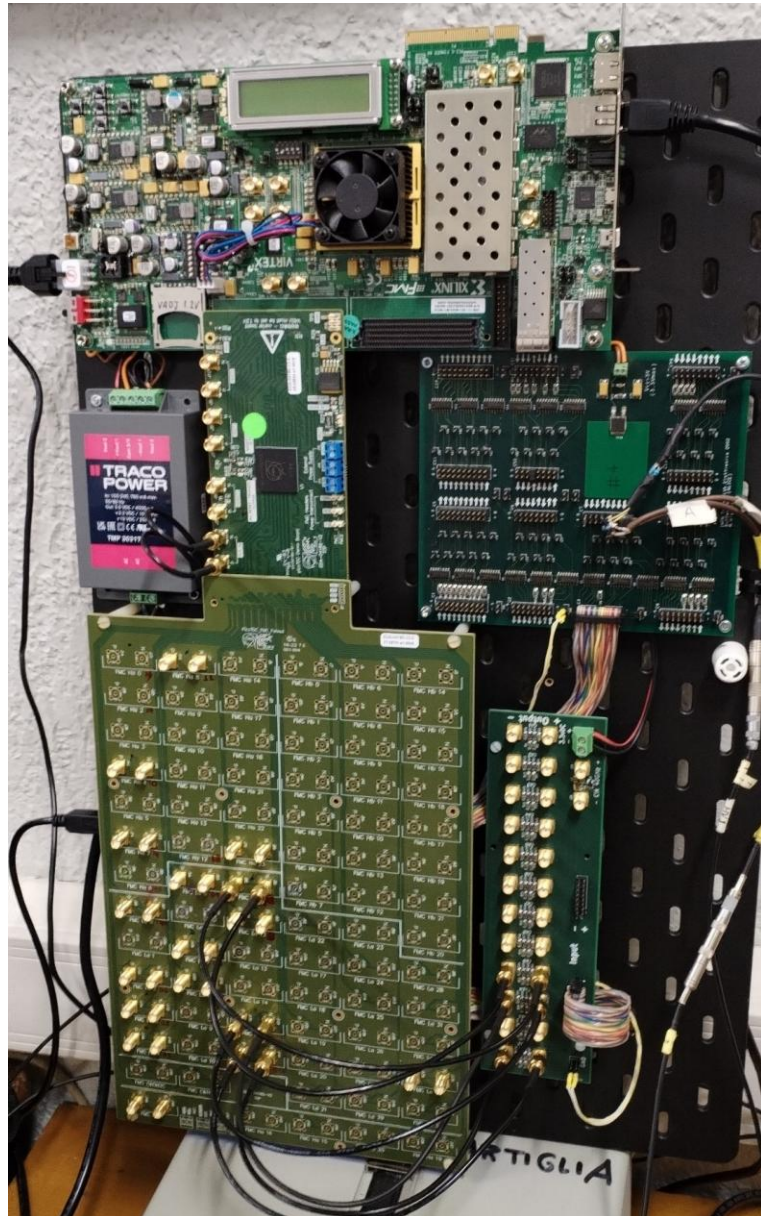

## CERN PicoTDC Demo Board

- **64 input channels (LVDS18)** and measures both TOA and TOT.
- Time LSB is **3.05 ps**, with a dynamic range of **205 microseconds**.
- streaming or triggered mode.
- Custom 12-channel level-translation board developed to convert **LVDS25** to **LVDS18**:
  - 8 primary signals from ESA-ABACUS
  - Up to 3 signals from secondary detectors

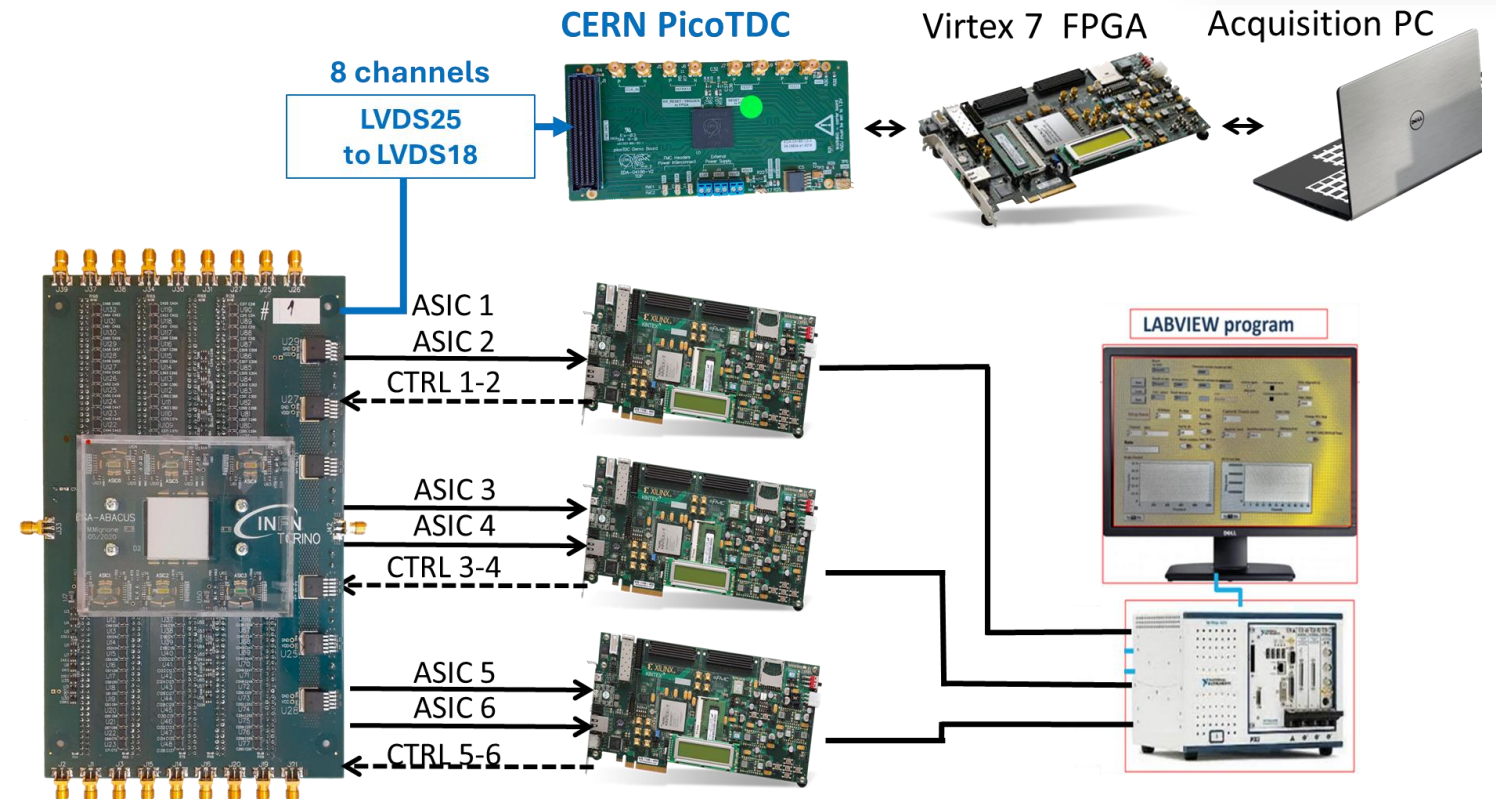
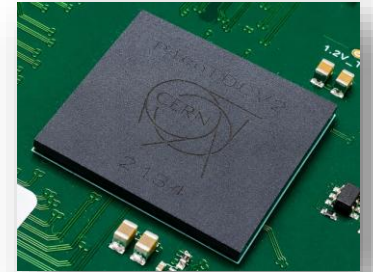

moving from waveform to high-resolution TDC timing, more suitable for high-rate acquisition.

# DAQ2: CERN PicoTDC-based system

## Experimental Tests at CNAO (Primaries Only)

- Clinical  $^{12}\text{C}$ -ion beam intensities: 20%, 50%, 100%
- **Seven energies** from 115.23 to 398.84 MeV/u
- **Triggered mode with 50 kHz external trigger**
- PicoTDC operated with 800-clock latency and 799-clock acquisition windows ( $\sim 20 \mu\text{s}$ ).
- **10 s acquisitions**
- No global trigger timestamp implemented (*rollover correction used instead*)

## TOA Channel Map

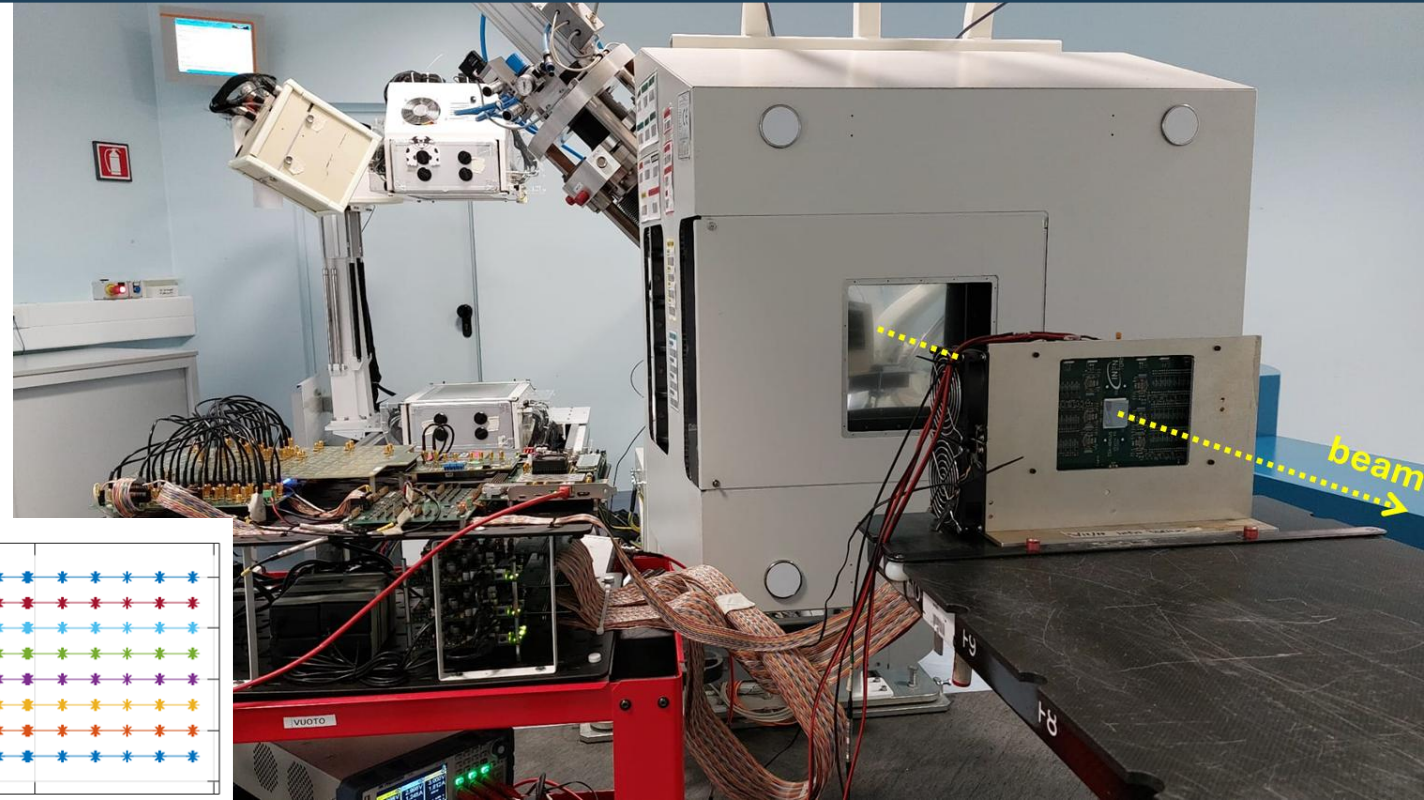
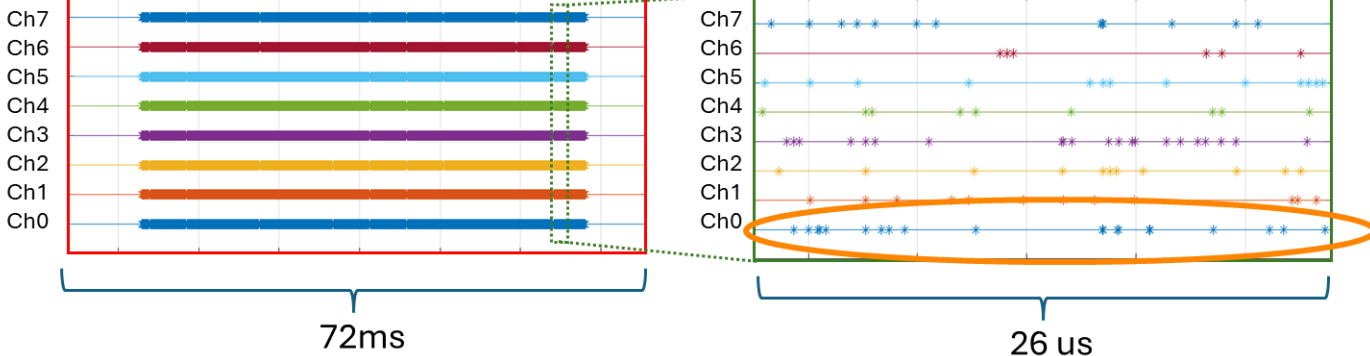
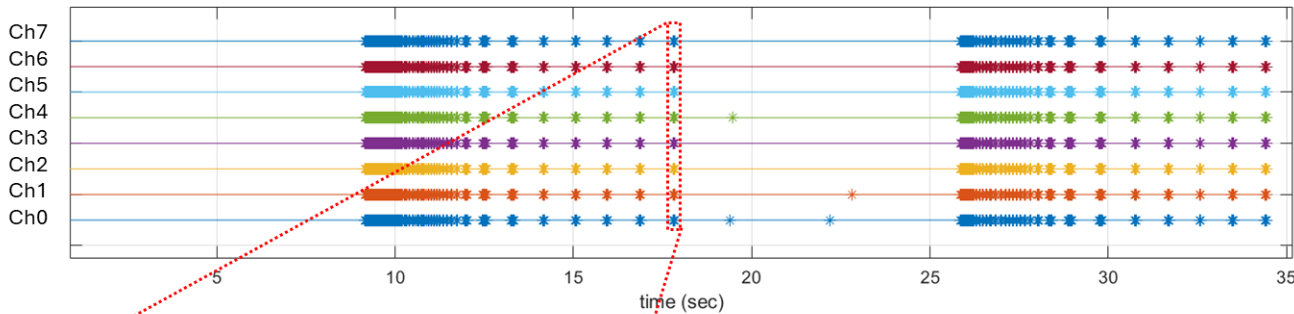

## Results

- **Proper operation within 20  $\mu\text{s}$  windows**
- **Temporal discontinuities appeared at high particle rates**, probably due to internal buffer saturation

# DAQ2: CERN PicoTDC-based system



Measurement of the RF period during betatron extraction

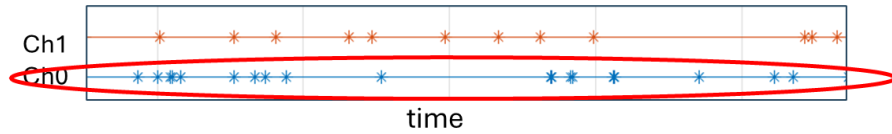

## Results

- The RF period was obtained from the hit inter-arrival time distribution and compared with the expected value.
- Agreement within 500 ps was observed in most cases.
- This showed that the system could preserve the time structure of the clinical carbon-ion beam.

## Inter-arrival time distribution (one channel)

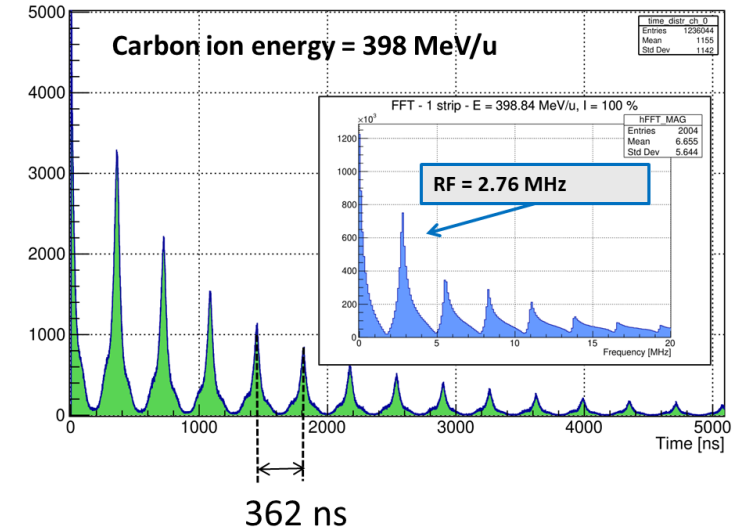
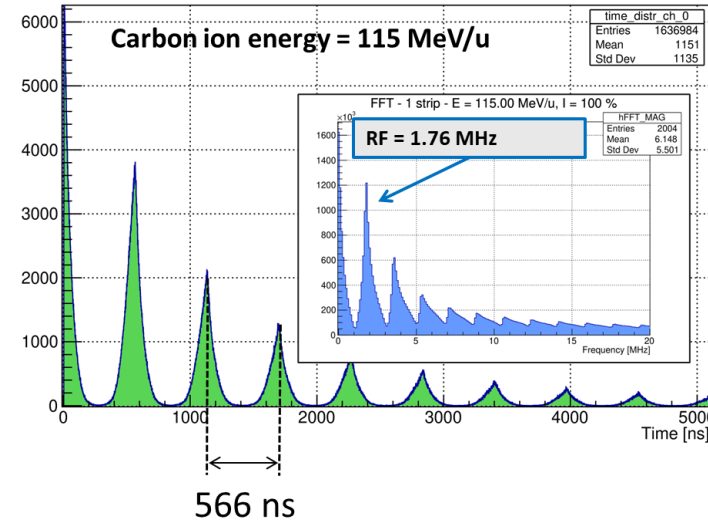

## Measured RF periods

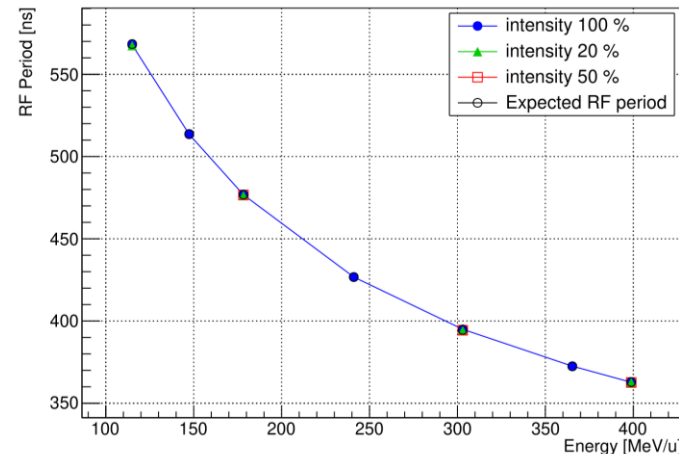

## Differences between RF periods

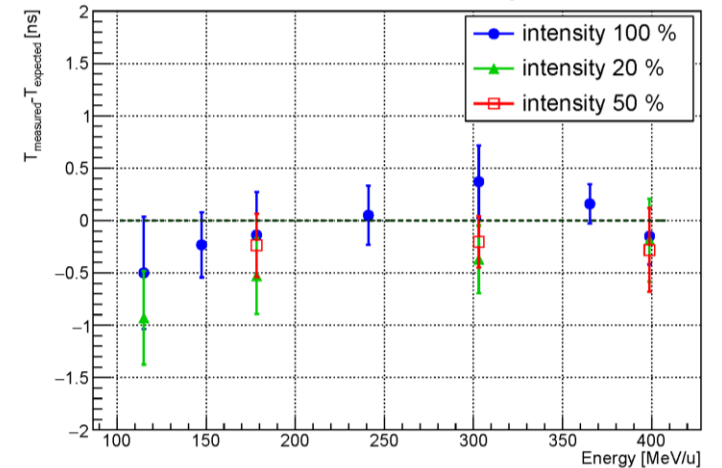

# DAQ2: CERN PicoTDC-based system

## Acquisition with secondary detector

- A CFD module, splitter, and adapters were used to generate LVDS signals from the secondary detector (sigma 10ps, FWHM ~24 ps)
- The secondary signal in ch8 was delayed by **56 ns** for trigger generation.
- Signals from ESA-ABACUS connected to PicoTDC ch 0–7.
- PicoTDC operated with 10-clock latency and 9-clock acquisition **windows** or 250 ns.

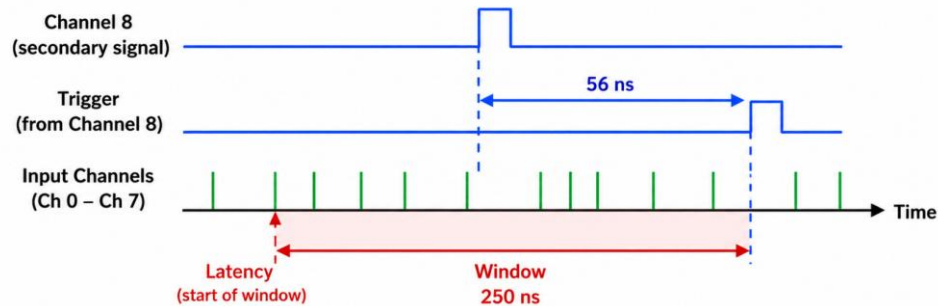

Coincidence tests with radioactive sources and two SiPMs achieved **~200 ps** time resolution

This confirmed that the timing chain was suitable for prompt-gamma timing.

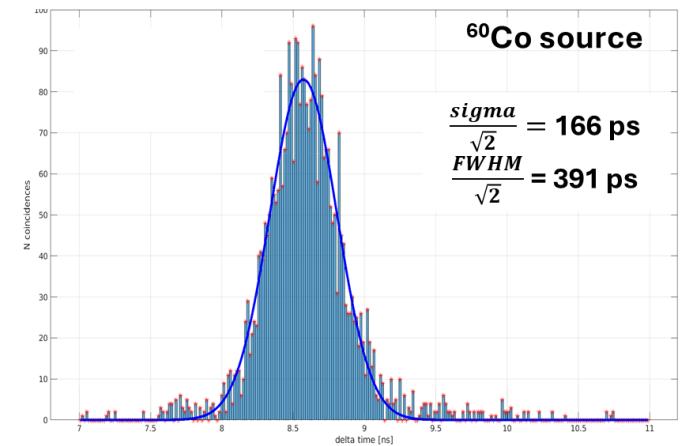
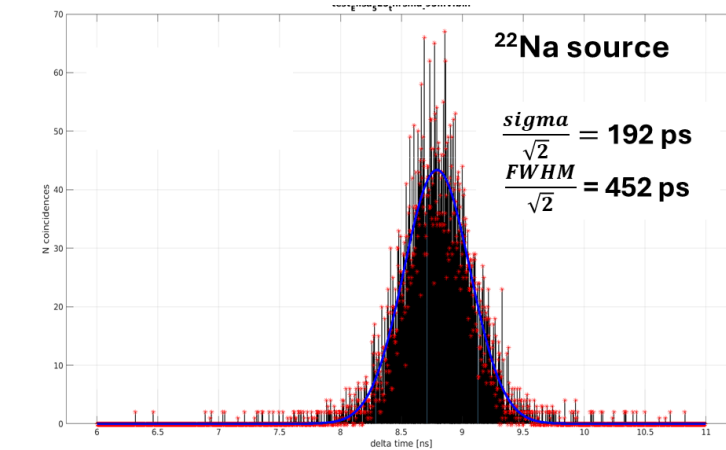
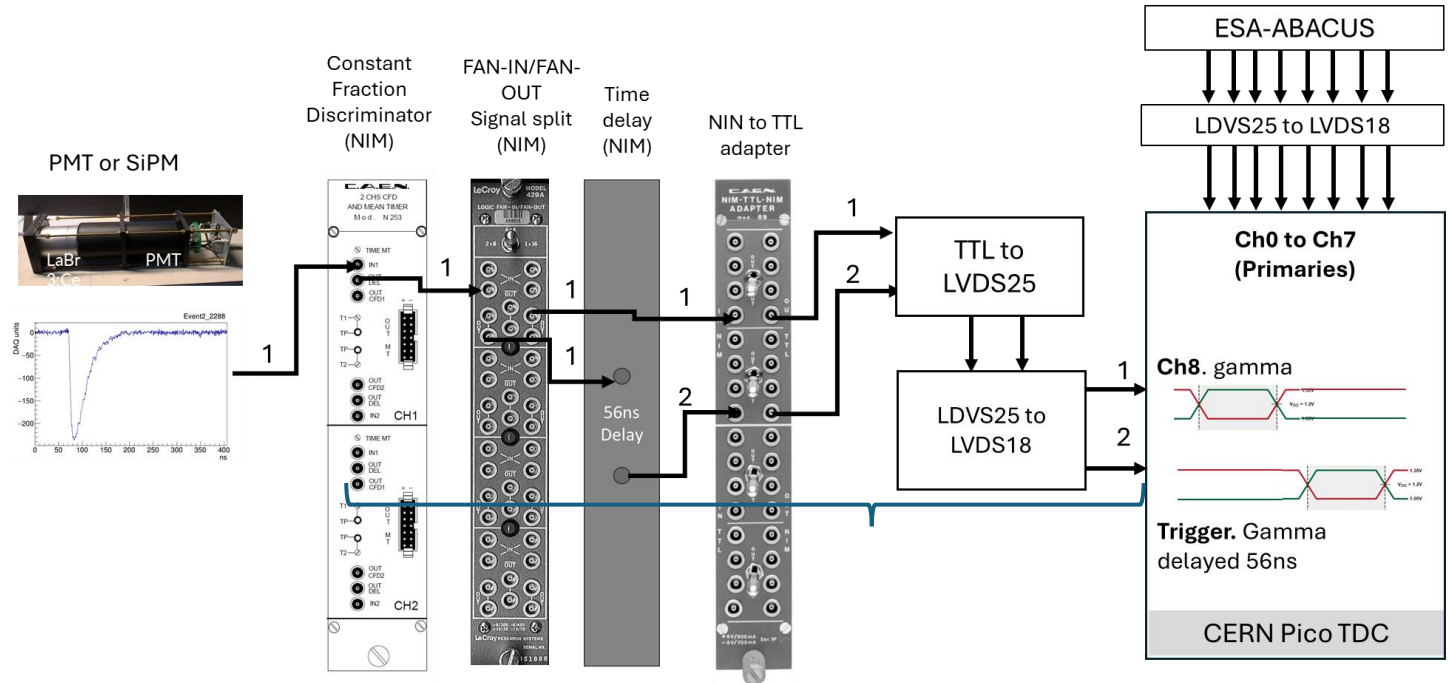

# DAQ2: CERN PicoTDC-based system

## Experimental test at CNAO

- **398.84 MeV/u carbon beam** at clinical rates and a three-slabs PMMA phantom.
- 511 keV gamma events were filtered by the CFD module.
- The acquisition time was **10 seconds**

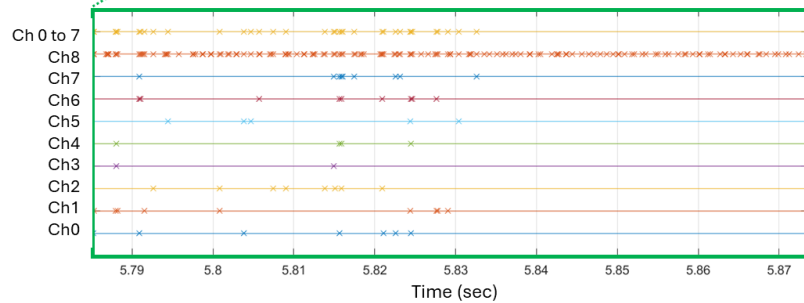
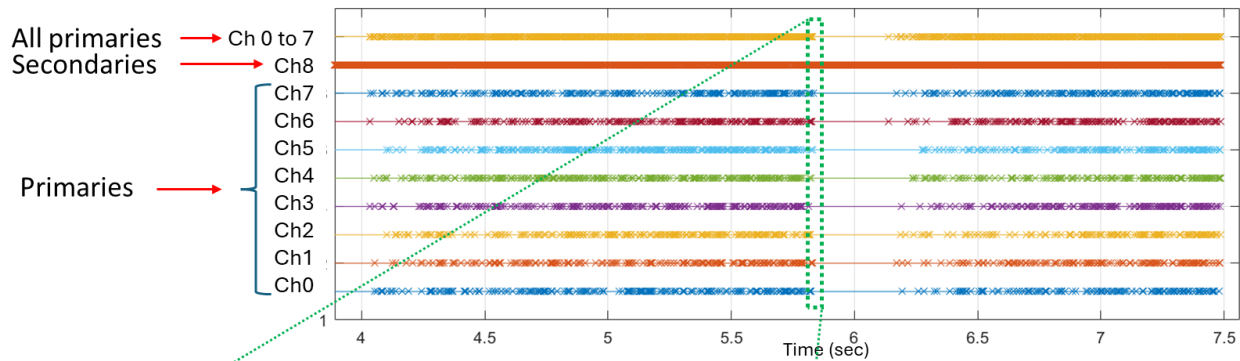

Example of triggered-mode spill acquisitions at clinical rates using 8 strips and 1 SiPM (discontinuities removed).

## PGT TOF distribution

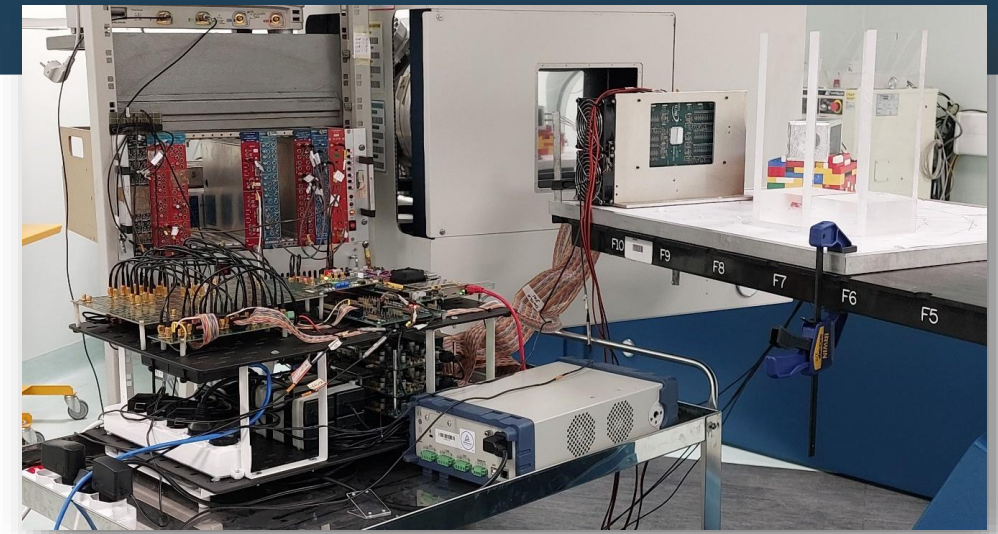
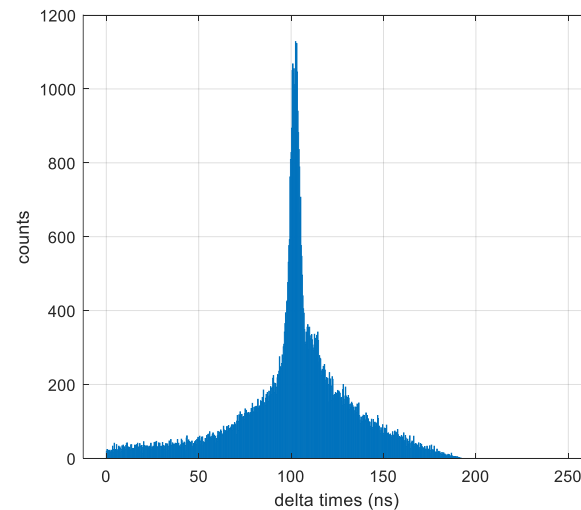

## Positive outcomes

- The system **achieved high-resolution TDC measurements** and the first successful acquisitions at **clinical rates**.
- **Higher duty cycle** and shorter acquisition times
- **High-resolution TDC measurements (~10 ps)**.

## Limitations

- The PMMA slabs could not be resolved in the **TOT distribution**.
- **Time-walk correction using the secondary TOT was required but not yet implemented**.
- **PMTs gave better timing resolution**, but they entered **overcurrent conditions at clinical rates**. **SiPMs were adopted**.

Shortly afterward, CAEN released the DT5203 PicoTDC, integrating analog inputs and simplifying the DAQ architecture.

# DAQ3: CAEN DT5203-based system with analog inputs

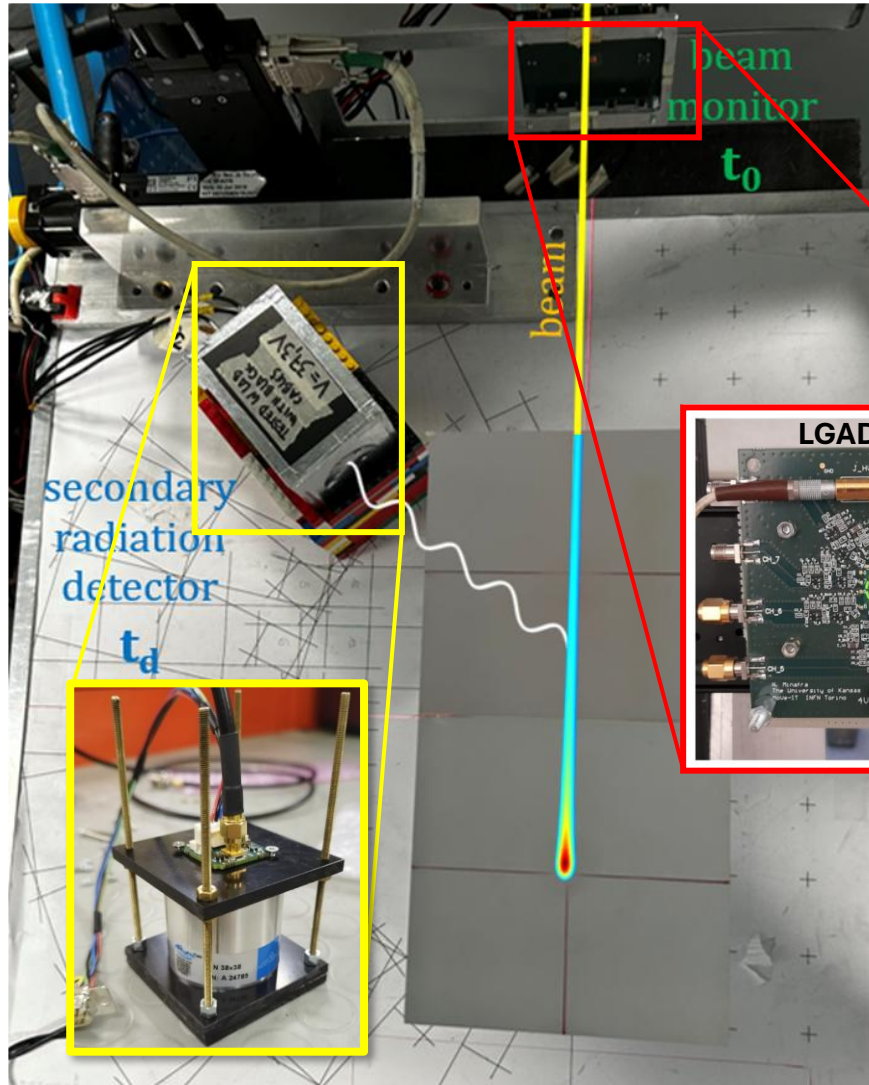

## DAQ3 architecture

- Adoption of the CAEN DT5203 PicoTDC-based system.
- Same timing resolution (3.125 ps).
- Support both analog and digital adapters (16-channel analog or 64-channel LVDS digital inputs.)
- Direct ESA-ABACUS LVDS connection supported (1.45 V max).
- Simplified acquisition software interface (Janus)
- Global trigger timestamping with forward and backward trigger matching.

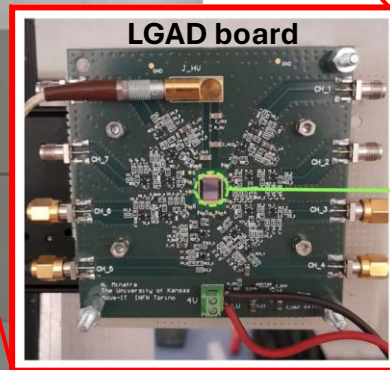

DT5203

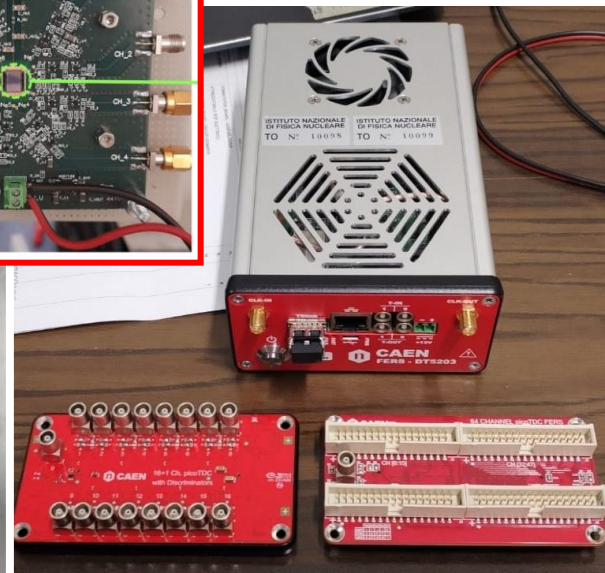

A5256

A5255



## Detectors setup

- 8-channel no gain LGAD board for primary <sup>12</sup>C detection connected to the odd A5256 channels
- Secondary detector LaBr<sub>3</sub>(Ce) (3.81×3.81 cm) coupled to a 5×5 SiPM matrix with custom analog summation, connected to channel 0 as trigger source.
- Laboratory timing resolution with <sup>60</sup>Co: ~340 ps

# DAQ3: CAEN DT5203-based system with analog inputs

## Experimental test at CNAO

- 399 MeV/u  $^{12}\text{C}$  beam at 10% clinical intensity ( $5 \times 10^6$  particles/s).
- 511 keV gamma filtered by the trigger and channel 0 threshold.
- SiPM positioned at 45° and 90° from isocenter.
- Compared
  - homogeneous PMMA target
  - PMMA target with 4 cm air gap

## DT5203 configuration

- Trigger mode (leading and trailing edge), 3.125 ps LSB.
- Latency: 300 ns; window: 600 ns.
- Energy selection and time walk correction from TOT

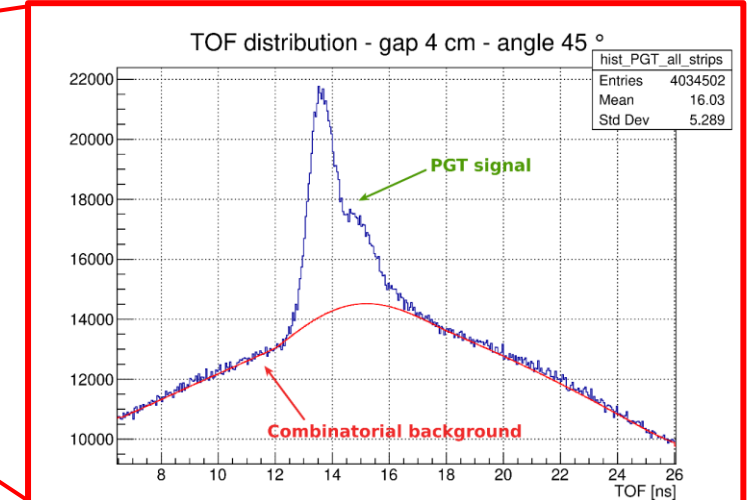
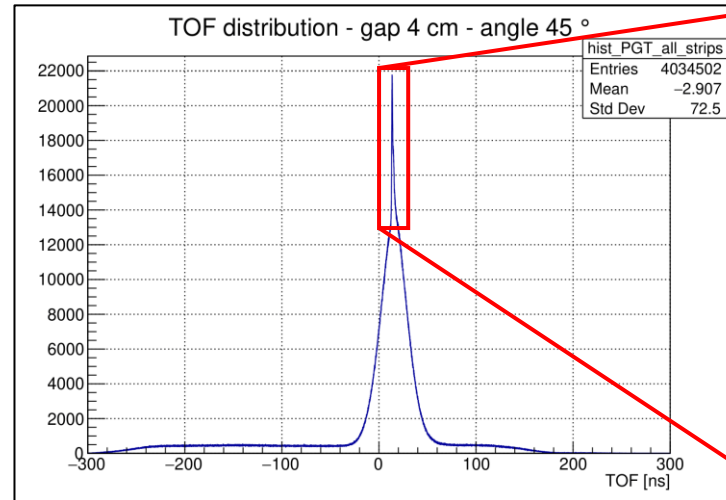
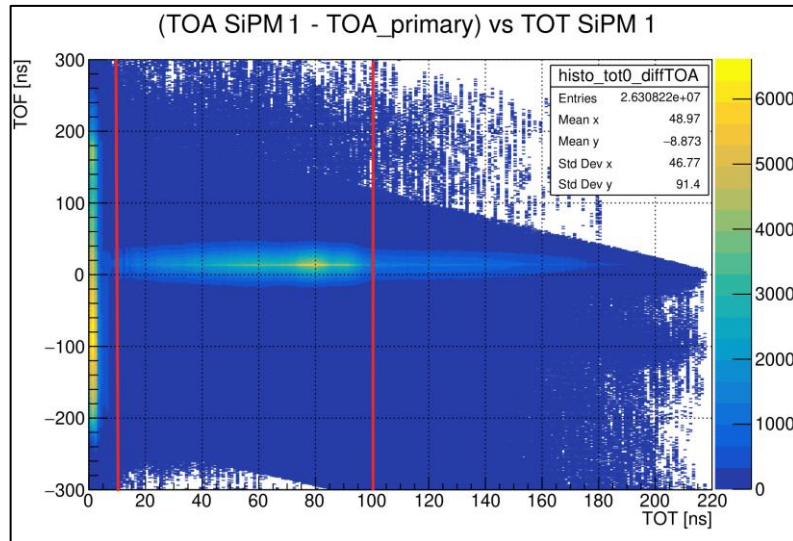
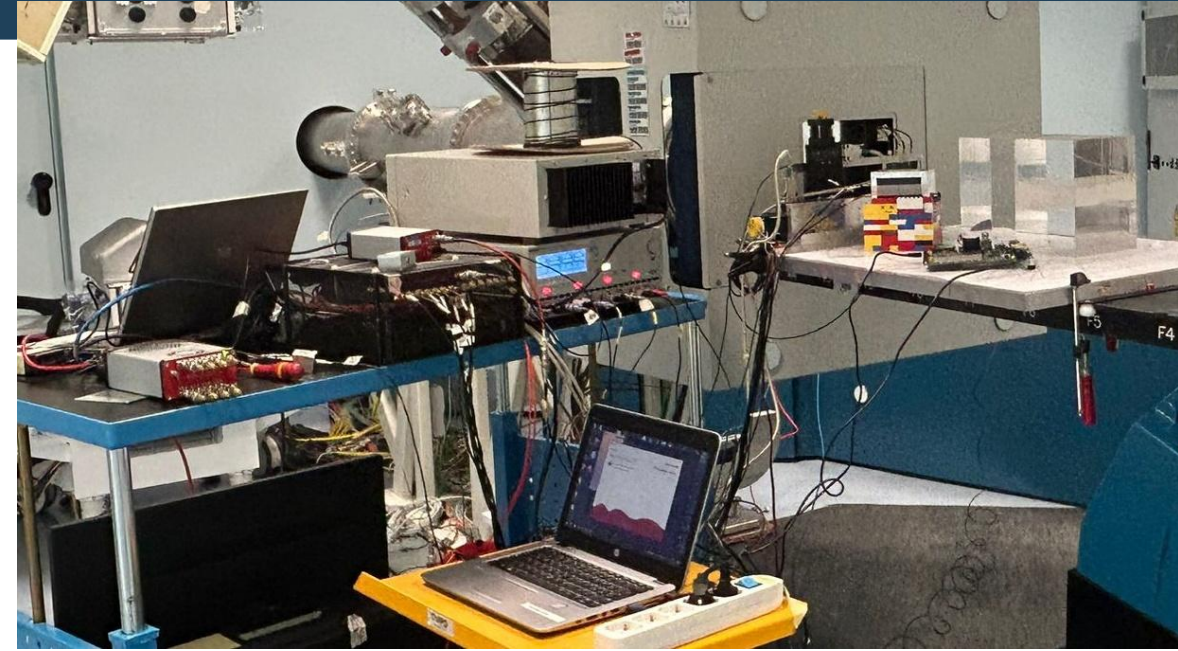

A correlation peak is observed above the combinatorial background

Important Indication that true primary-gamma coincidences could be identified

# DAQ3: CAEN DT5203-based system with analog inputs

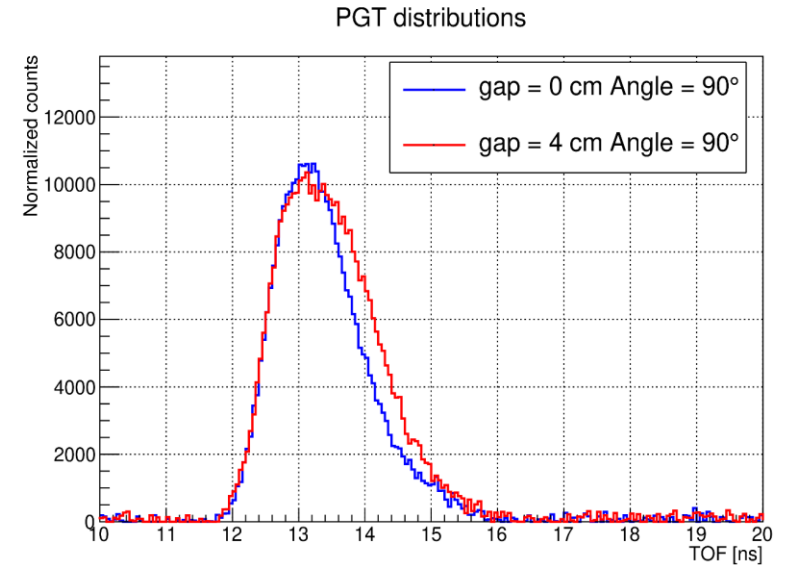
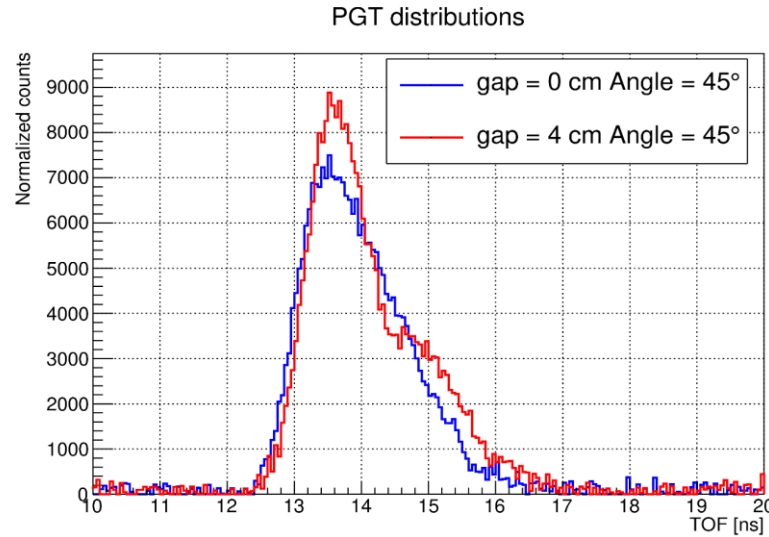
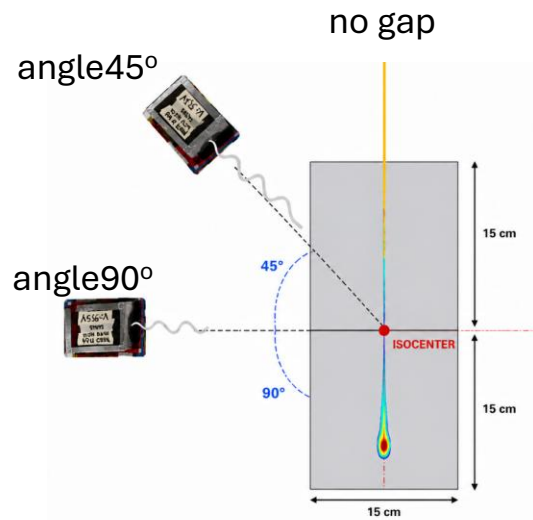

## Results

- **Reduced prompt-gamma production inside the air gap** and a broader distribution due to the longer particle range
- **Timing resolution was sufficient to resolve the expected difference** between the two configurations.

## Limitations

- **Trigger timestamp discontinuities** due to buffer saturation
- Low number of analog inputs limited the true coincidence rate and increase the combinatorial background.

## Positive outcomes

- **Demonstrated the detection of a 4 cm air cavity between PMMA blocks at 10% of clinical carbon-ion intensity.**
- The coincidence time resolution of the **LaBr<sub>3</sub> plus SiPM plus PicoTDC system** was about **250 ps**.

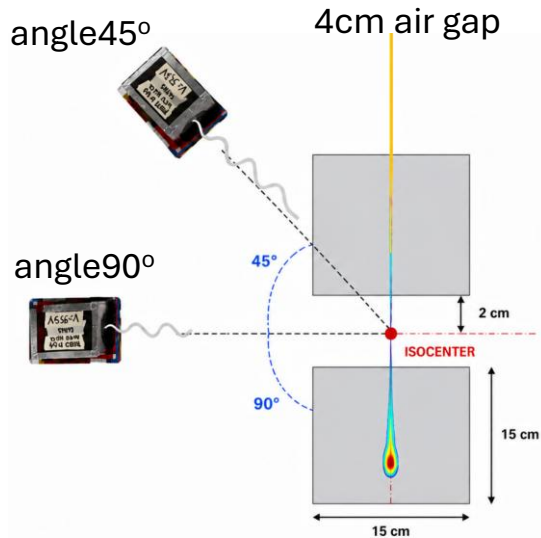

# Current status. DAQ4: CAEN DT5203-based architecture with 64 digital LVDS inputs

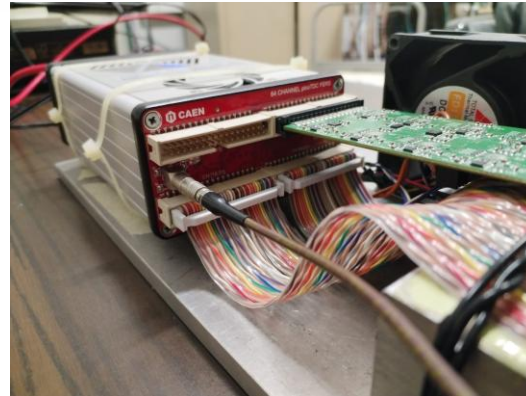
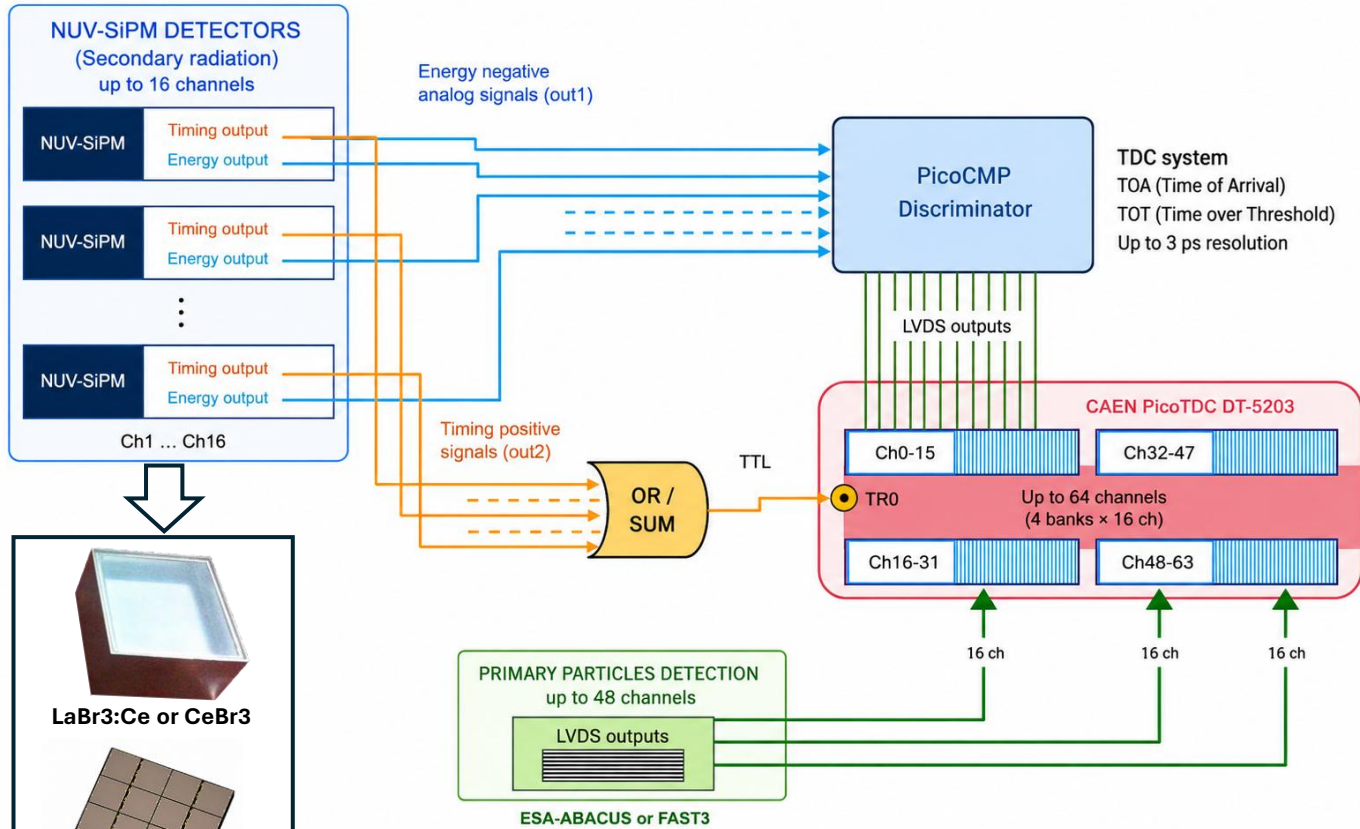

## Status of the project

- More compact and high-rate system.
- For the primary detector: **ESA-ABACUS** or **FAST3 ASICs**, in order to maximize the number of primary channels.
- Secondary detector: testing **NUV-SiPMs** (providing fast timing and energy-proportional signals)
- Evaluating LVDS conversion using the **16-channel PicoCMP discriminator** developed by INFN Genova.

The objective: a compact DAQ architecture with more channels, better rate capability, and simpler integration



## Conclusions

- **Successive DAQ architectures** for PGT range verification were **experimentally evaluated**.
- **Digitizer-based** systems showed **good timing performance** but **limited duty cycle** and **scalability**.
- **CERN PicoTDC** and **CAEN DT5203** systems achieved **TOA** resolutions of **tens of ps** for **primaries** and **~250 ps** for **secondaries**, demonstrating **PGT feasibility at clinical rates**.
- **Current developments** target compact high-rate **DT5203** architectures with **64 digital inputs** and **NUV-SiPM** secondary detectors.



# Conclusions

- **Successive DAQ architectures** for PGT range verification were **experimentally evaluated**.
- **Digitizer-based** systems showed **good timing performance** but **limited duty cycle** and **scalability**.
- **CERN PicoTDC** and **CAEN DT5203** systems achieved **TOA** resolutions of **tens of ps** for **primaries** and **~250 ps** for **secondaries**, demonstrating **PGT feasibility at clinical rates**.
- **Current developments** target compact high-rate **DT5203** architectures with **64 digital inputs** and **NUV-SiPM** secondary detectors.

**Despite these promising results, collaborations on new DAQ developments are welcome.**

**Thank you for your attention!**

# Backup

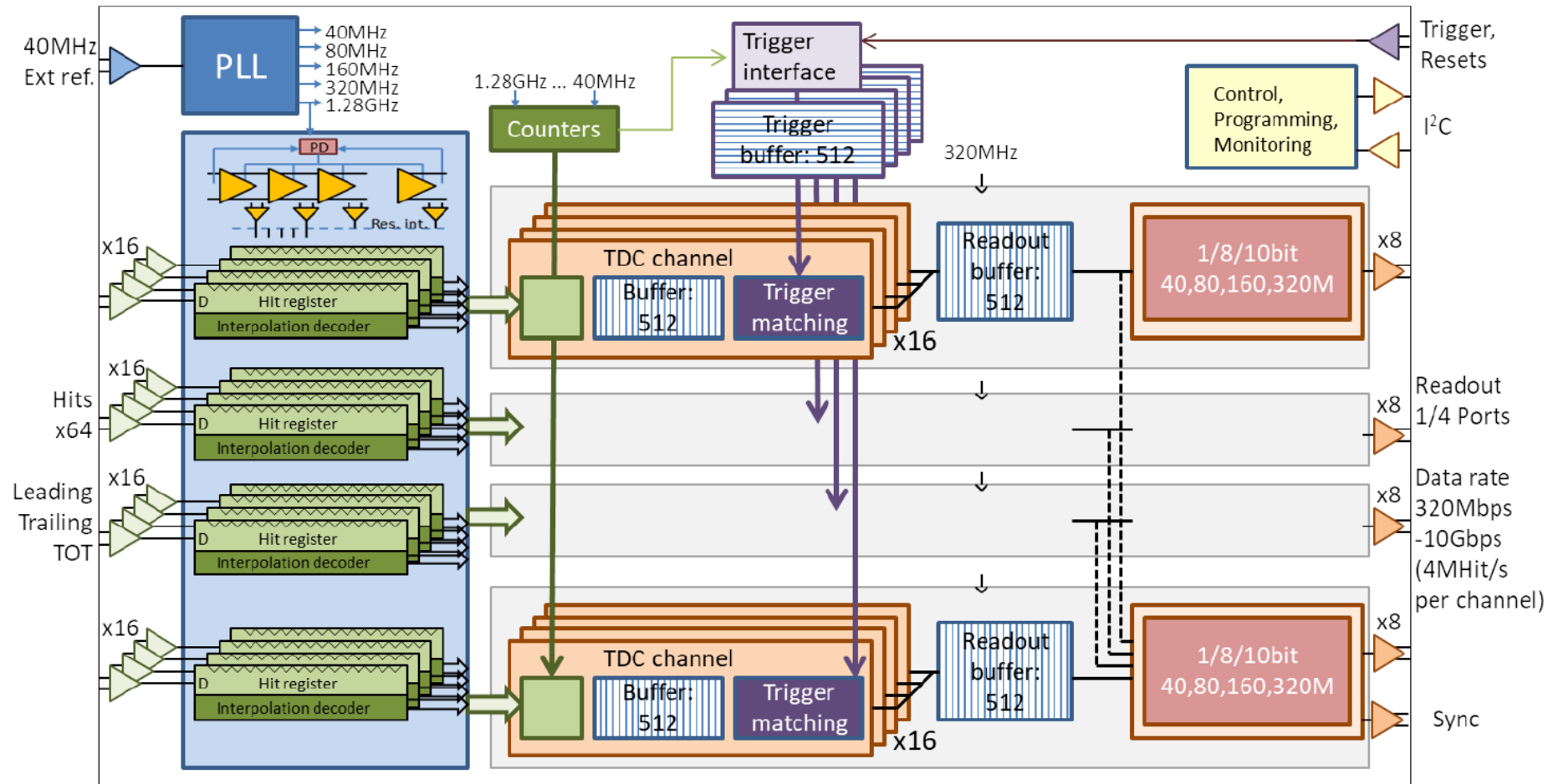

**Figure 1.** Architecture and data flow in 64 channel PicoTDC.

<https://doi.org/10.1088/1748-0221/18/07/P07012>

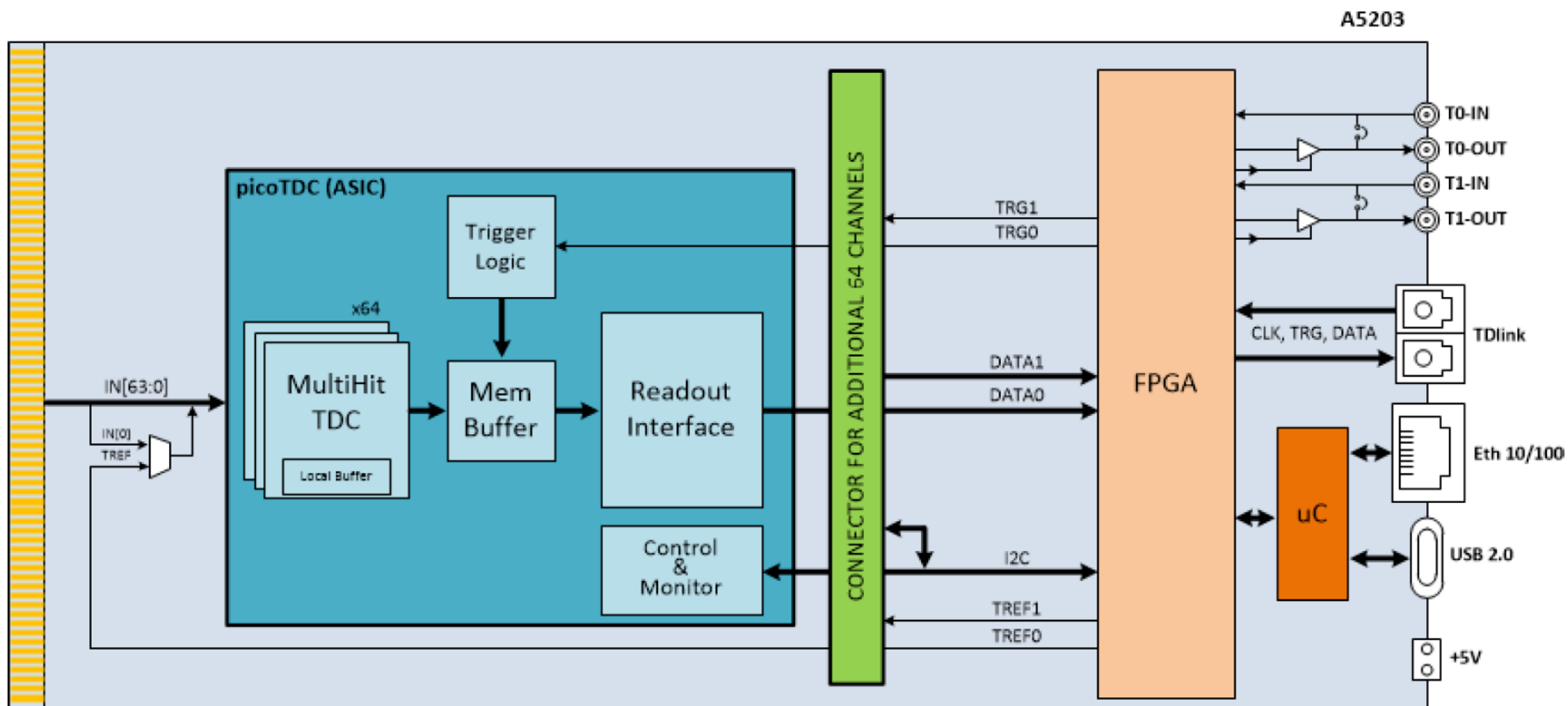

**Fig. 1.1:** Simplified block diagram of the A5203/DT5203 FERS-5200 unit.