

Timing Distribution Method via 10-km Optical Fibers at the J-PARC for the Hyper-K Project

Che-Sheng Lin^{A,B},

Eitaro Hamada^A, Ian Benjamin Heitkamp^C, Yota Hino^{A,B}, Ryotaro Honda^{A,B}, Ken Sakashita^{A,B}

^AKEK IPNS, ^BSOKENDAI, ^CTohoku University

This work is supported by the JST K-program
(Grant No. JPMJKP24J2).

T2K (Tokai to Kamioka)/HK Experiment

Long-baseline neutrino oscillation experiment

- Neutrino Oscillation

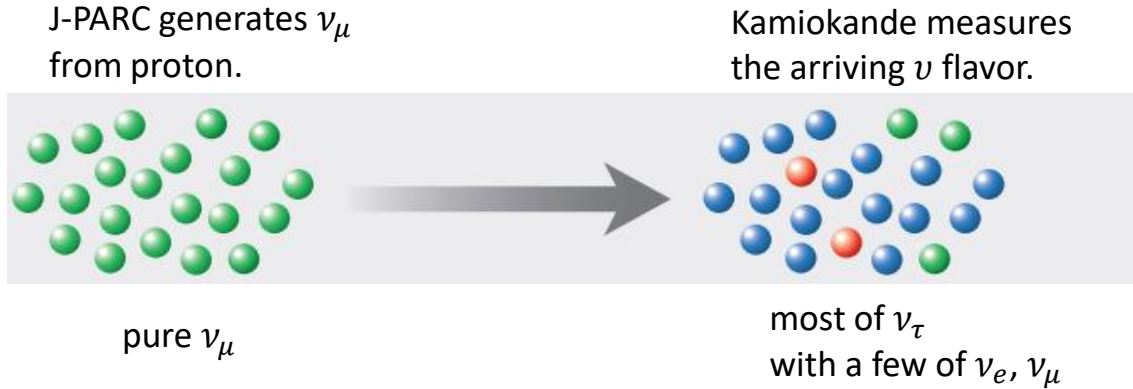
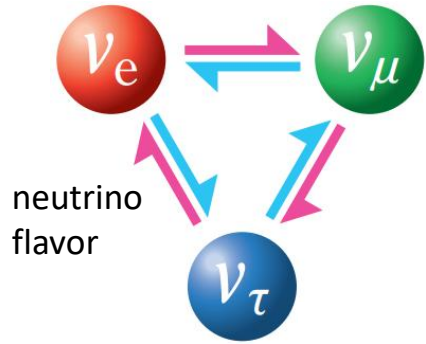

- Neutrino flavors change after traveling some distance.

- T2K Experiment

- Super-Kamiokande

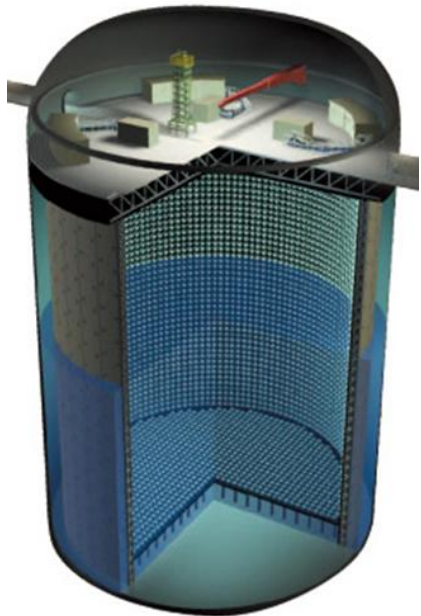

- Near Detectors

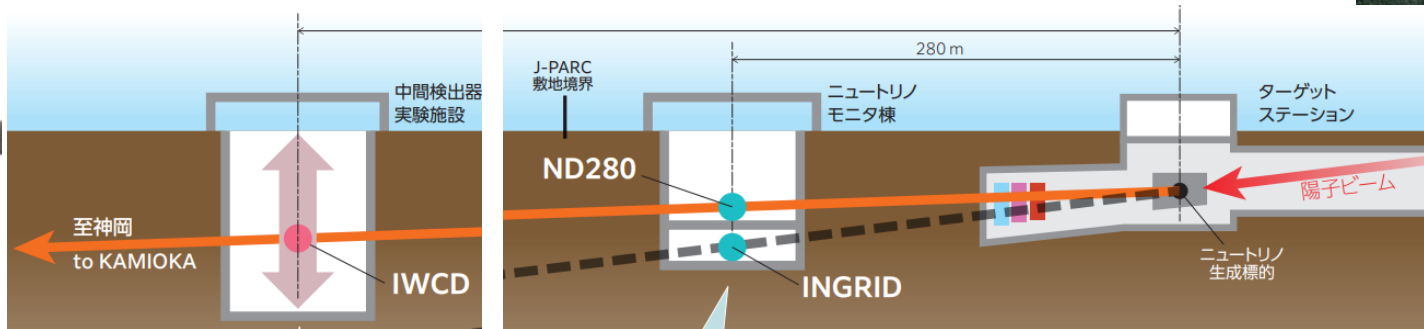

- J-PARC

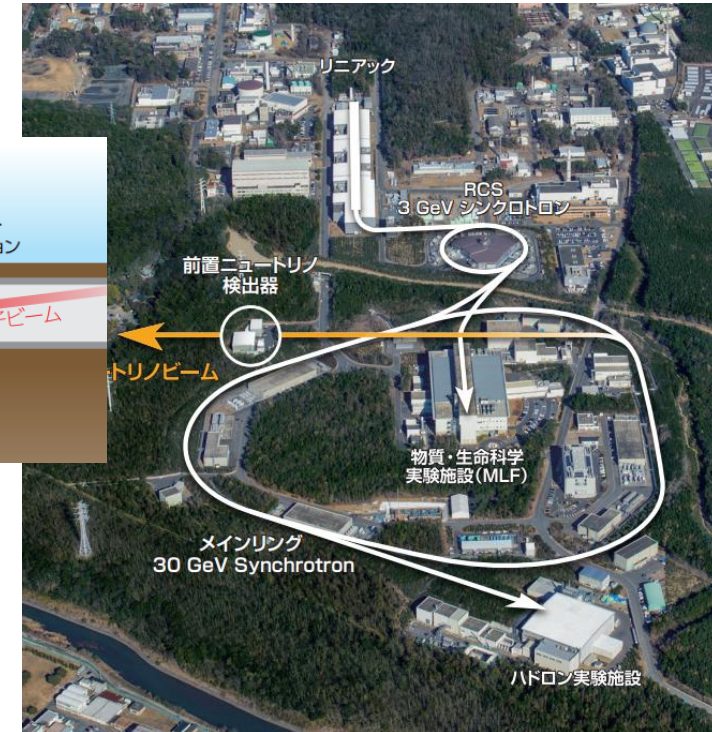

- Muon neutrino (ν_μ) beam is generated from the J-PARC main-ring (MR) proton beam.
- The neutrino flavor is measured by Super-Kamiokande after traveling 295 km.

J-PARC Site of T2K Experiment

Fast-extraction (FX) and beam kicking pulse signal

- Neutrino beam

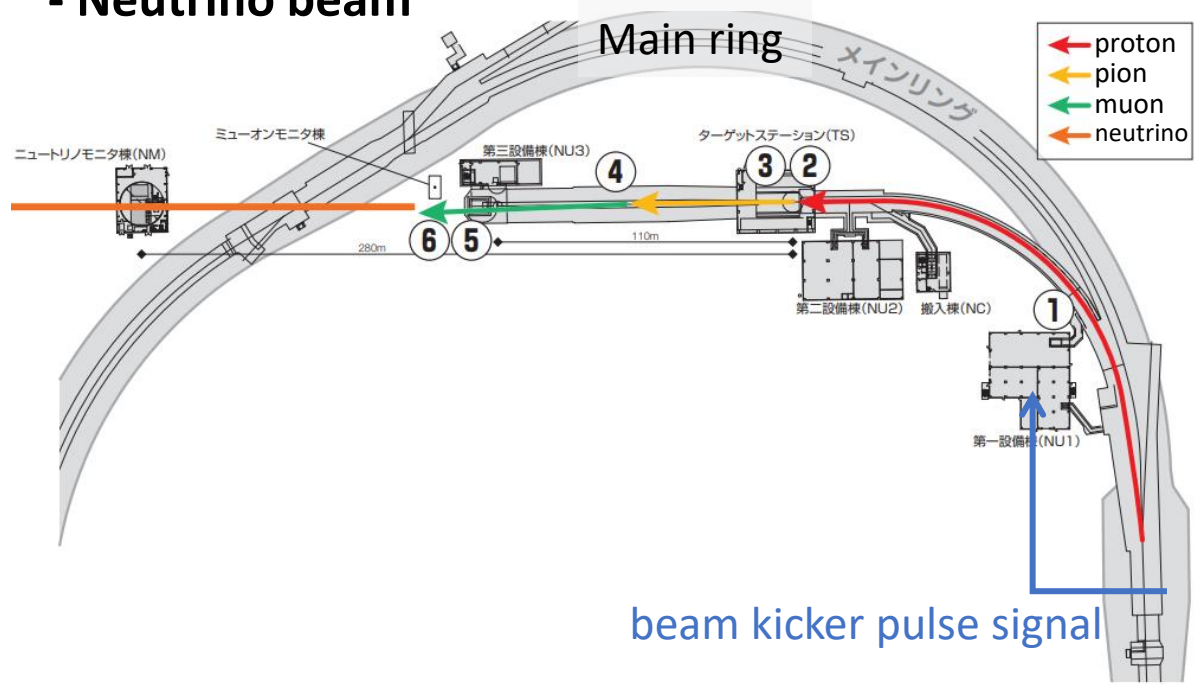

- The MR delivers a beam kicker timing pulse signal.

- MR fast-extraction (FX) mode

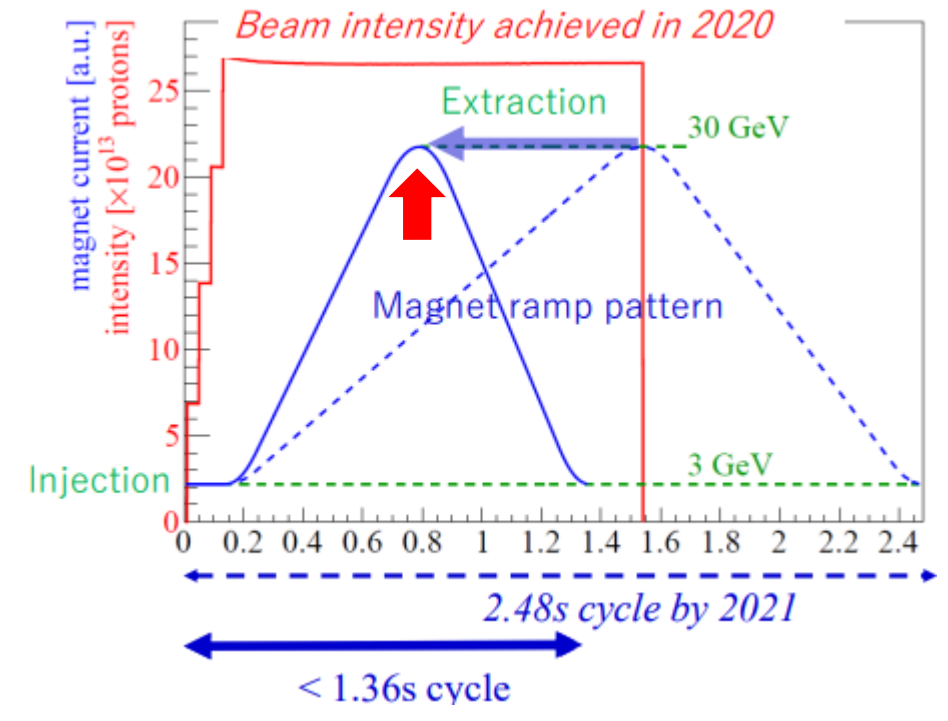

- The period of the fast-extraction (FX) mode is 1.3s.

Timing Distribution System

Distribute the beam trigger and spill number

- Neutrino beam

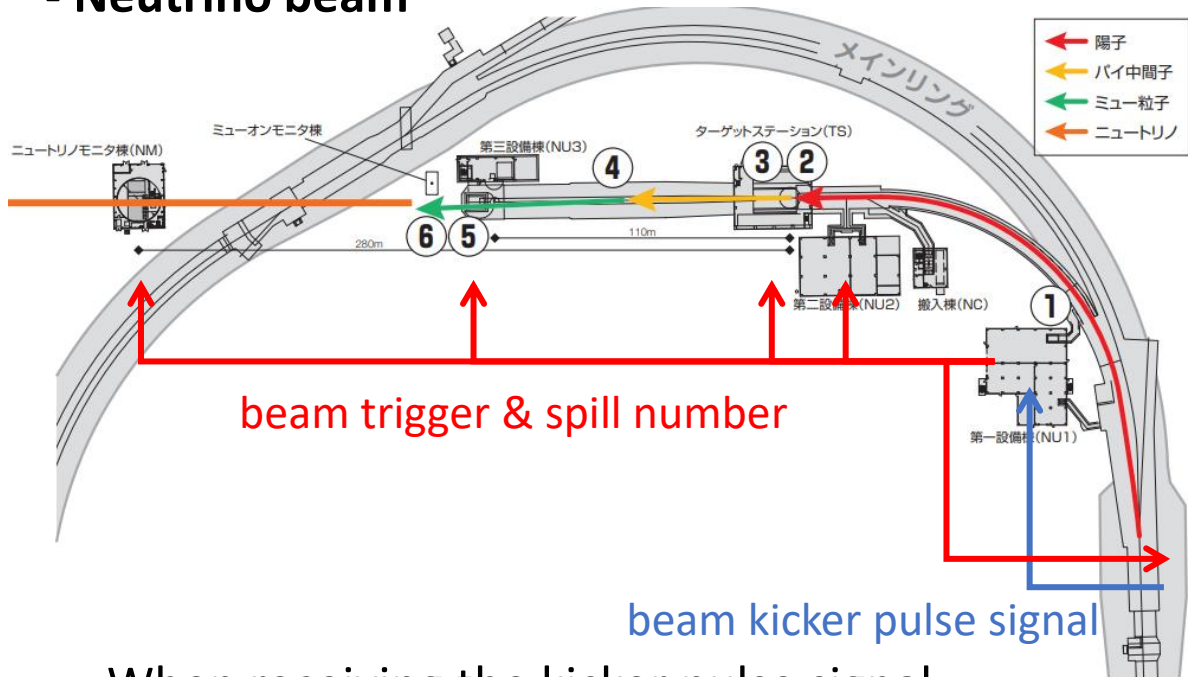

- When receiving the kicker pulse signal, the timing distribution system distributes the **beam trigger pulse signal** and **spill number** to each neutrino facility.

- Requirements:

- Beam trigger pulse signal with spill number
- No trigger loss
- Timing accuracy < 1 ns
- Transmission distance > 10km
- Transmission latency < 1 ms

- Local time clock (LTC) at the J-PARC site

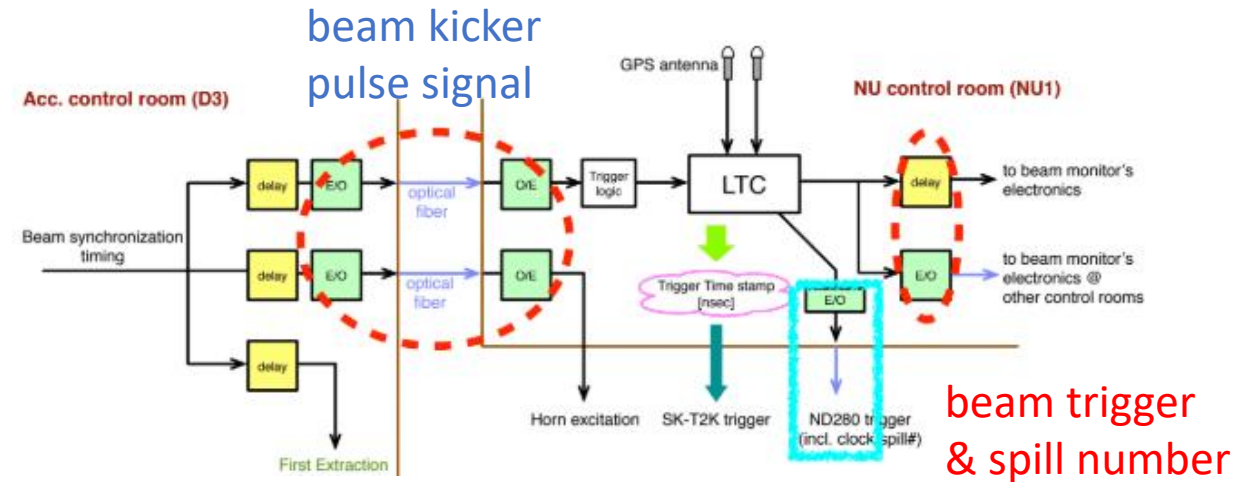

- Developed during the K2K era over 20 years ago.
- Several modules have exceeded their production lifespan and are no longer available.
- The system occasionally suffers from signal dropouts.
- ➔ We aim to develop a **new transmission method** to replace the current system for the future Hyper-K experiment.

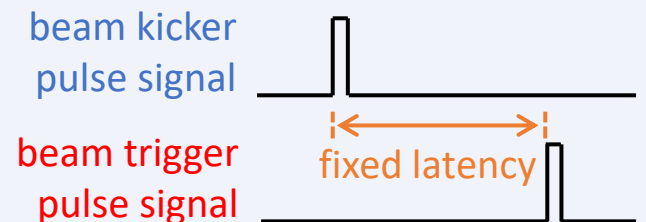

1. Timing Distribution Method
2. Phase Compensation Method
3. Implementation

Method of Timing Distribution System

Principle: digitize analog pulse signals for transmission

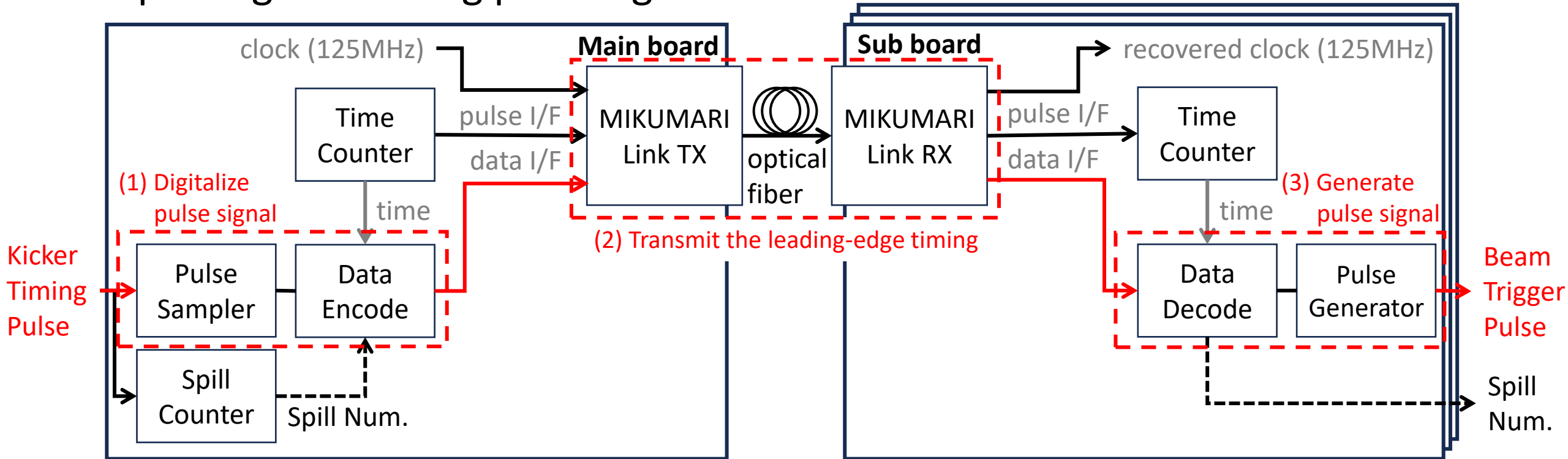

- Principle:

Digitize analog pulse signals for transmission

(1) Main board:

Digitalize the pulse signal.

(2) MIKUMARI link protocol:

Transmit the leading-edge timing of pulse signal.

(3) Sub board:

Generate the pulse signal at the corresponding timing.

Method of Timing Distribution System (0)

Prepare the synchronize time counter

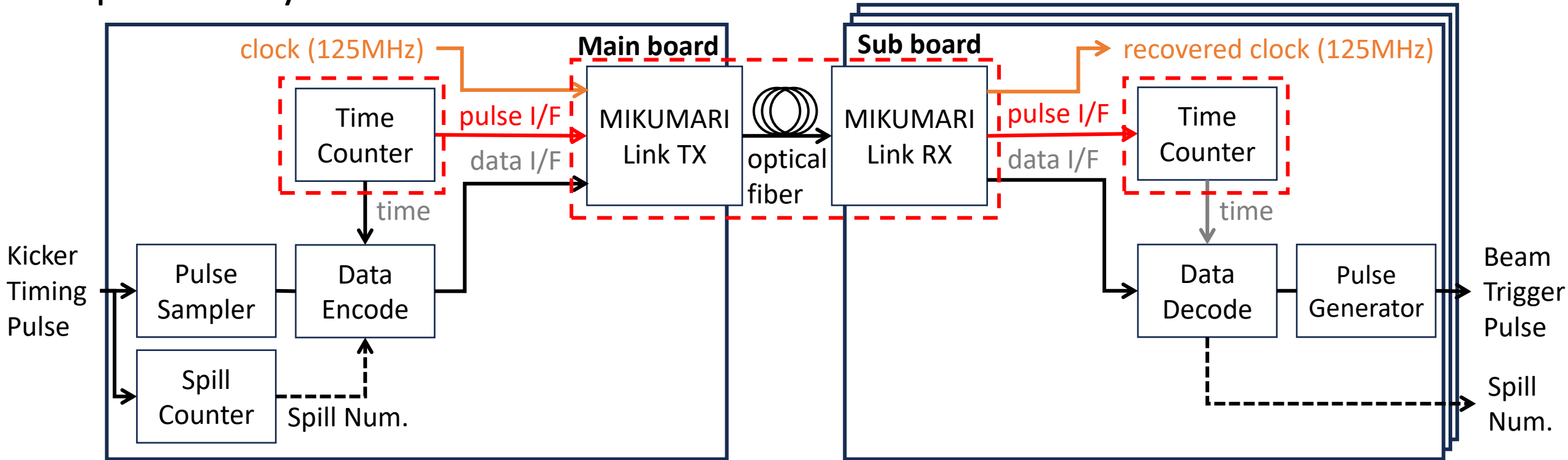

(0) Prepare the synchronize time counters:

- (0.1) MIKUMARI signal serves as a reference clock to **recover the synchronized clock on the Sub board.**
- (0.2) Periodically **synchronize the time counter** via **pulse I/F**. The time counter values have a fixed offset, which depends on the transmission latency of the pulse I/F.

Note: interface (I/F) of MIKUMARI link protocol:

1) clock I/F:

- synchronous clock signal of **125 MHz (8 ns).**

2) pulse I/F:

- pulse signal with **fixed latency** and 3-bit data width.

3) data I/F:

- DC-balanced data frame (a few 8-bit characters)
- transmission **latency with slight uncertainty**

Method of Timing Distribution System (1)

Digitalize the kicker timing pulse signal

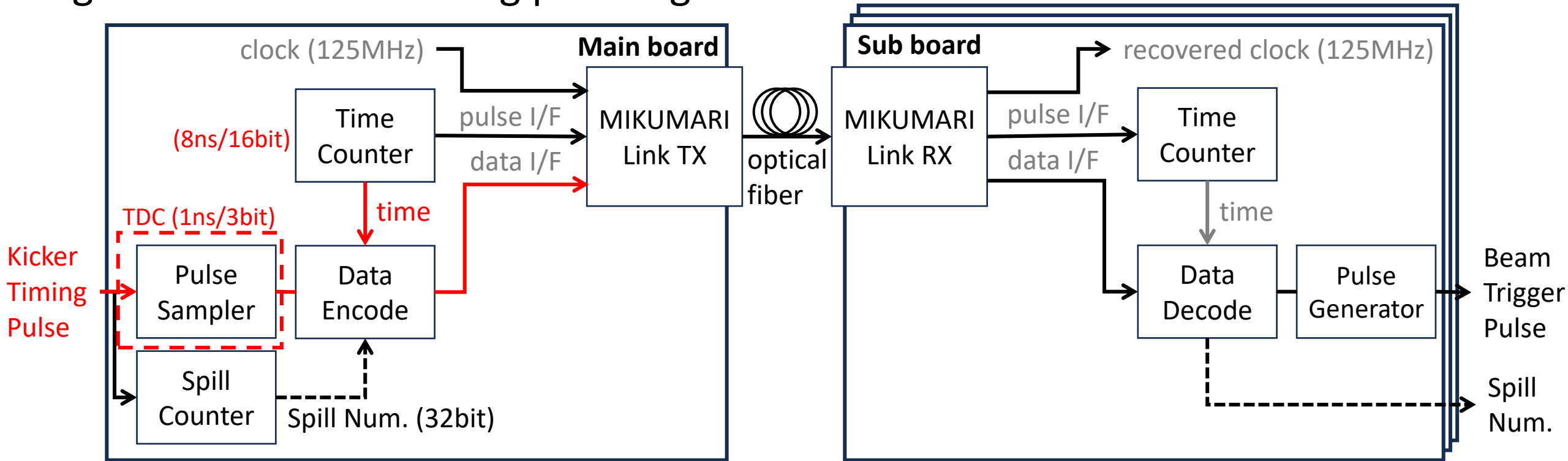

(1) Digitalize the kicker timing pulse signal:

- (1.1) Measure the **leading-edge timing** of the pulse signal.
(1 ns-resolution TDC implemented by the ISERDES primitive.)
- (1.2) **Measured timing** = timing counter + pulse sampler
(8ns/16bit) (1ns/3bit)
- (1.3) **Spill number** for identifying the beam trigger (32bit).

Note: 1ns TDC (1-to-8 ISERDES)

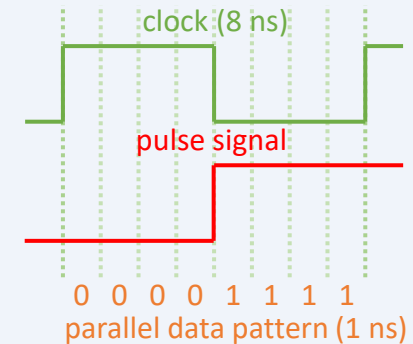

Method of Timing Distribution System (2)

Transmit the leading-edge timing and spill number

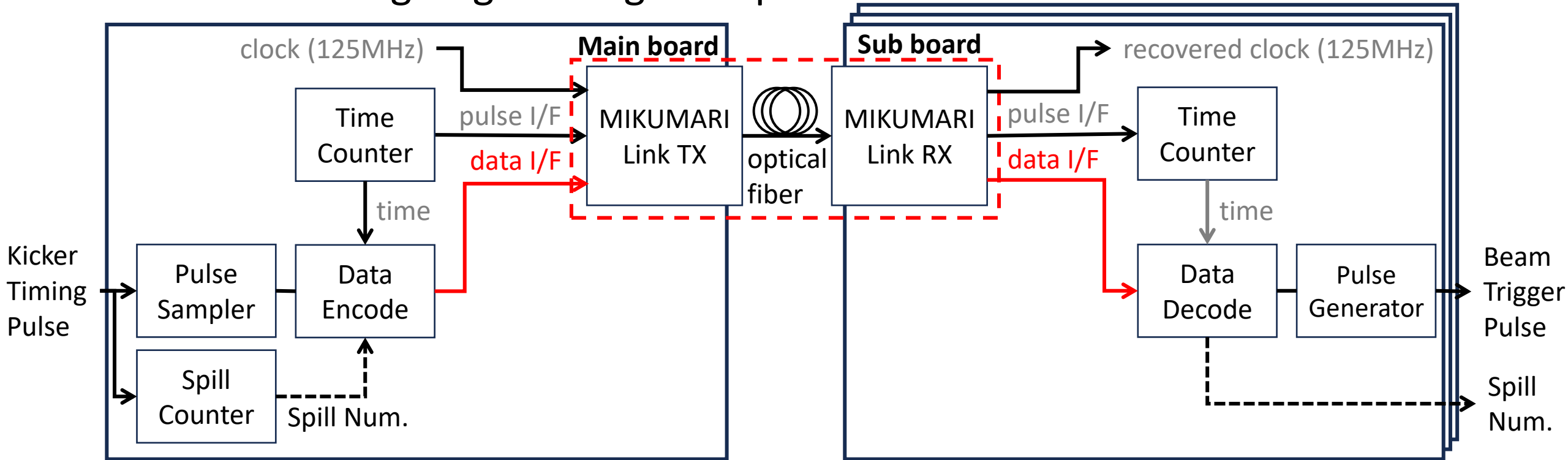

(2) Transmit the leading-edge timing and spill number:

- (2.1) Transmit the information of pulse signal by **data I/F**
leading-edge timing + spill number
(16+3 bit) (16 bits)
(spill number: 32 bits(total)/16 bits (delivered))

Note: interface (I/F) of MIKUMARI link protocol:

- 1) clock I/F:
 - synchronous clock signal of 125 MHz (8 ns).
- 2) pulse I/F:
 - pulse signal with fixed latency and 3-bit data width.
- 3) data I/F:
 - DC-balanced data frame (a few 8-bit characters)
 - transmission latency with slight uncertainty

Method of Timing Distribution System (3)

Generate the pulse signal at the corresponding timing

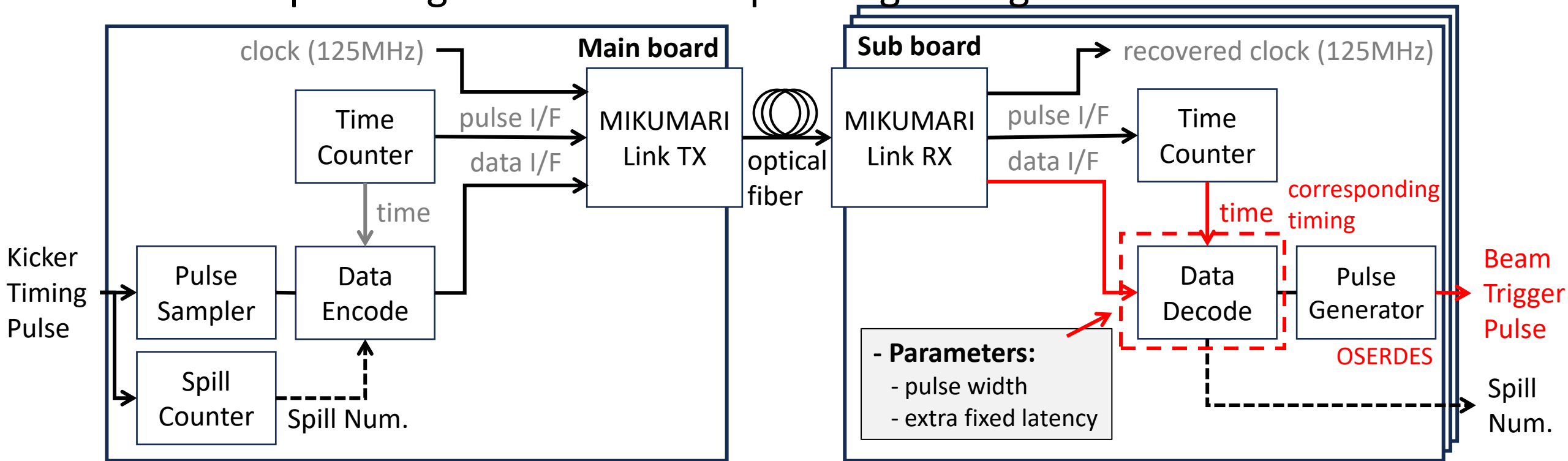

(3) Generate the pulse signal at the corresponding timing:

(3.1) Generate the pulse signal at the corresponding timing.
(leading-edge timing + **pulse width**)

Note: transmission latency: data I/F > pulse I/F
→ add an **extra fixed latency** to ensure receiving of data from the data I/F.

(3.2) Use the OSERDES primitive to achieve 1ns accuracy.

Time counter
(main board)

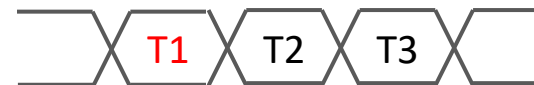

Kicker timing
pulse signal

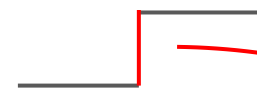

Time counter
(sub board)

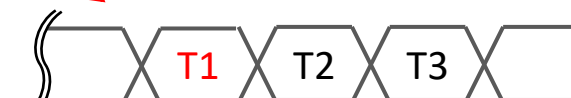

Beam trigger
pulse signal



1. Timing Distribution Method
2. Phase Compensation Method
3. Implementation

Phase drift of 10km Optical Fiber Link

Phase shift caused by temperature

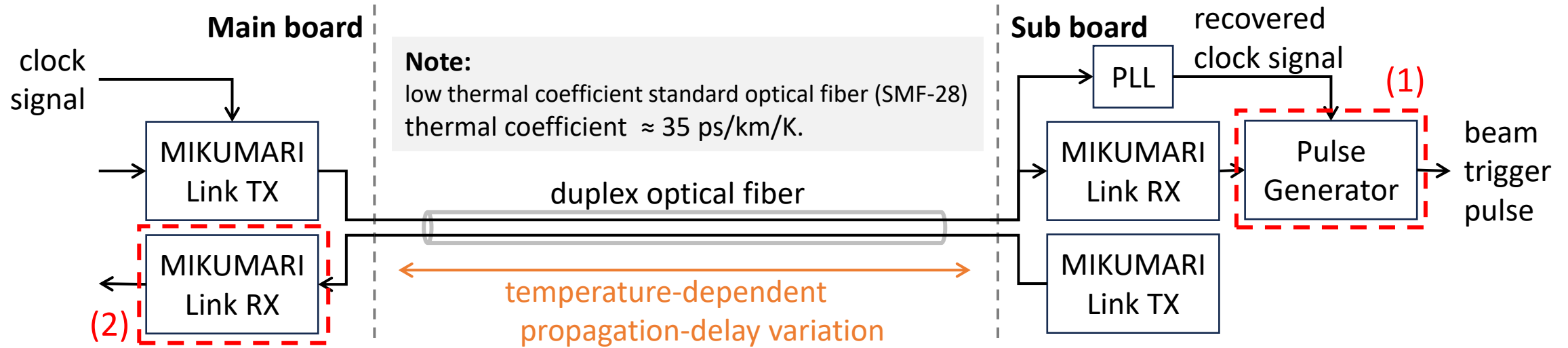

- For a 10-km optical fiber link, temperature-dependent propagation delay variations **cannot be neglected**.

(1) Drift of beam trigger pulse signal:

Pulse signal generation is based on the recovered clock signal

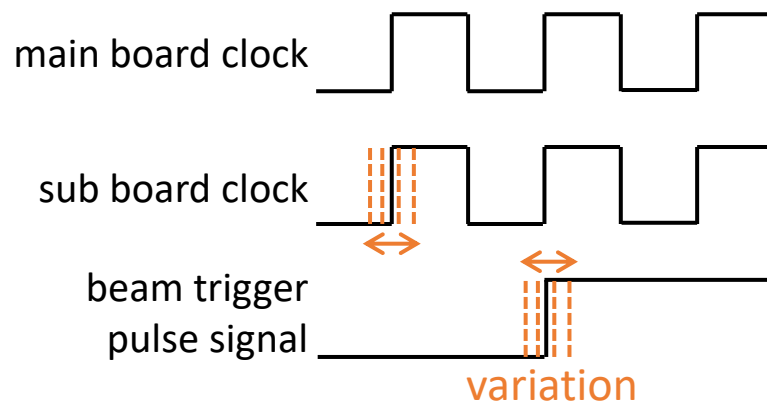

(2) Decoding error of MIKUMARI RX of main board:

Decoding by the MIKUMARI RX on the main board relies on the main-board clock.

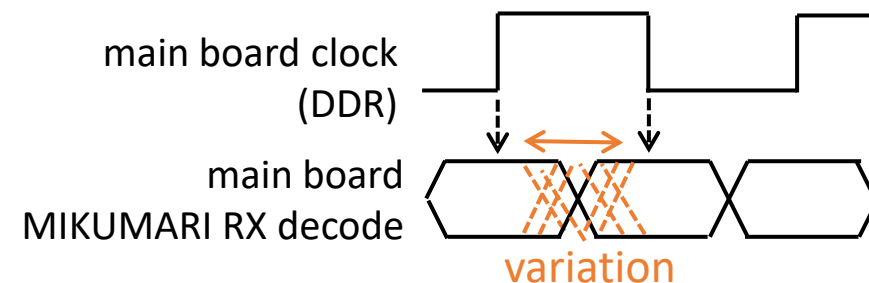

Phase compensation of 10km Optical Fiber Link

Phase measurement and compensation

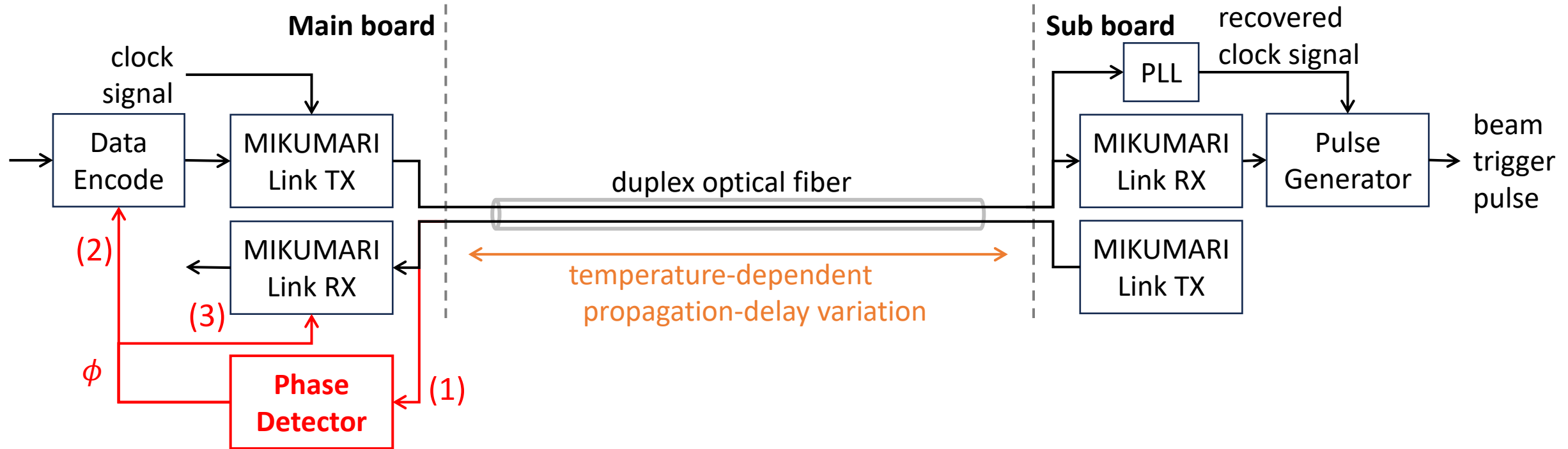

- (1) The temperature-dependent phase shift can be measured by comparing the **returned MIKUMARI modulated clock** signal with the **local main-board clock**.
- (2) Leading-edge timing is added to the phase compensation to **mitigate the drift of beam trigger pulse signal**.
$$T_{pulse w/\phi} = T_{pulse} - \phi/2$$
- (3) MIKUMARI RX of main board dynamically adjusts the IDELAY taps and bit slip based on the measured phase shift to **keep the sampling point centered**.

Phase Measurement

Digital dual mixer time difference (DDMTD)

- The DDMTD **down-converts** a high-frequency clock signal into a low-frequency beat signal.

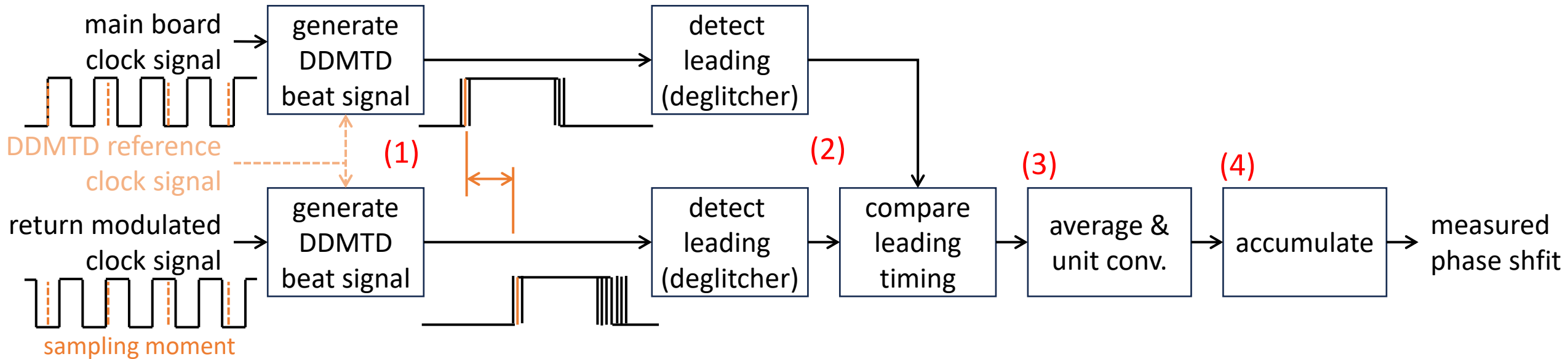

(1) The DDMTD reference clock signal with **slightly lower frequency** is used to sample the measured clock signals, and generate the DDMTD beat signal with lower-frequency. ($f_{DDMTD} = f_{measured} - f_{reference}$)

(2) The DDMTD beat signal preserves the measured clock signal phase.

➔ The phase difference can be measured from the DDMTD beat signal phase difference.

(3) Multiple phase samples are averaged to obtain a stable phase estimate.

(4) The measured phase is accumulated to track long-range phase shift.

Phase compensation

For leading-edge timing of pulse signal

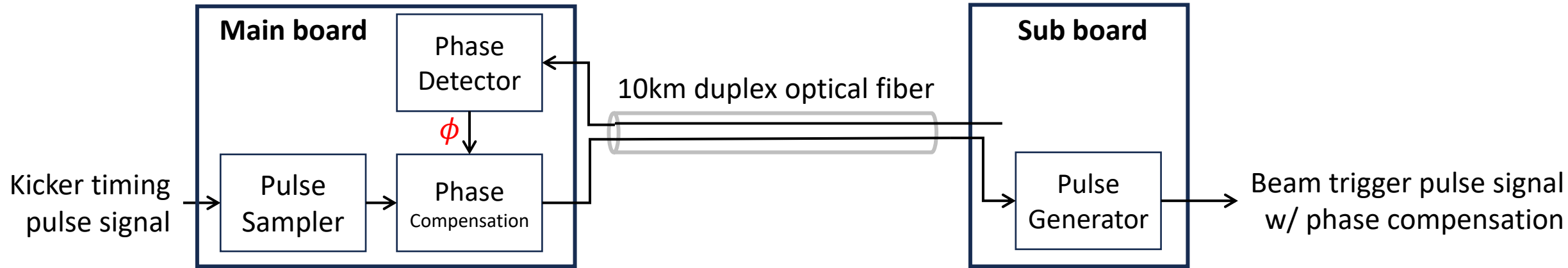

- Phase detector

- Measure the **phase shift** (ϕ)

- Phase compensation

- Since the measured phase shift is round trip variation, the leading-edge timing of pulse signal (T_{pulse}) compensates half of phase shift.

$$- T_{pulse\ w/\ \phi} = T_{pulse} - \phi/2$$

- Pulse sampler

- 1 ns-resolution TDC
- 8-to-1 OSERDES
- unit interval: 1 ns

- Pulse generator

- Achieve the fine compensation
- 8-to-1 OSERDES + **ODELAY primitive**
- unit interval: **78 ps**

1. Timing Distribution Method
2. Phase Compensation Method
3. Implementation

Testbench of Timing Distribution System

Tested by a 10km optical fiber

- Fiber Optic Cassette

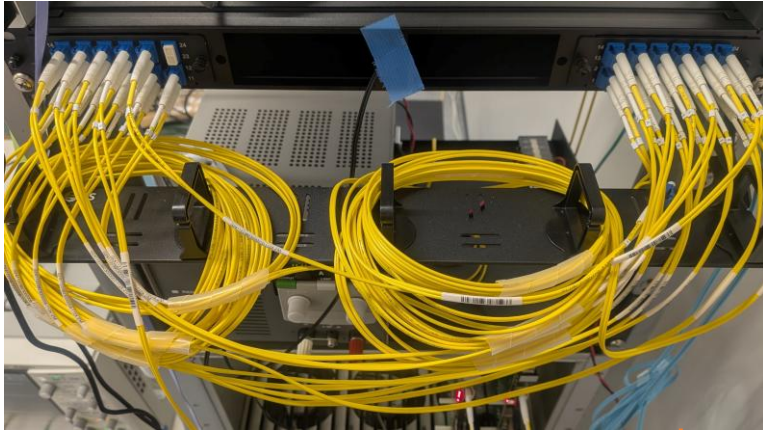

- Thermo recorder



- AMANEQs

10 km optical fiber

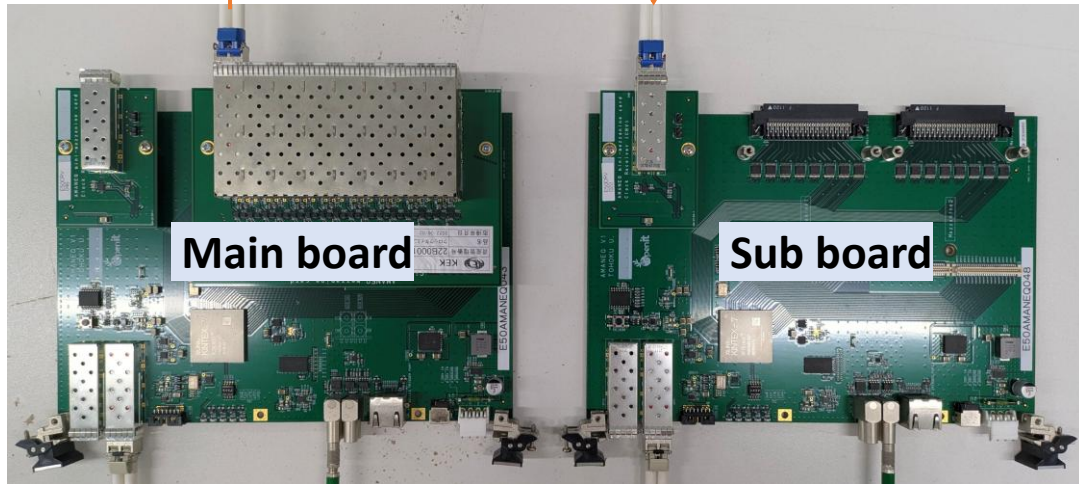

PC

Kicker timing
pulse signal

PC

Beam trigger
pulse signal

- AMANEQ: a general main electronics for trigger-less data acquisition system
- FPGA: Kintex-7, XC7K-160T-2FFG676-2
- PLL: CDCE62002
- NIM_IN: SN65LVDS348PWR
- NIM_OUT: SN65CML100D
- SFP: SFP1G-LX-31 (1G/1310nm/20km)
- Optical fiber: 24F MTP-MTP trunk cable (1310nm/1km)
fiber patch cable (1310nm/2m)
- Fiber Optic Cassette: FHD-1MTP12LCOS2AF
- Oscilloscope: KEYSIGHT DSOS054A (2GHz Upgrade)
- Thermo recorder: TANDD TR-71nw

- The testbench of timing distribution system is implemented by AMAENQs.

- NIM input of Main board receives the pulse signal.

- NIM output of Sub board generates the pulse signal.

- Pulse information is transmitted by 10 km optical fiber with MIKUMARI link protocol.

- Main board measures phase shift.

- Thermo recorder records the room temperature.

Result of Phase Shift and Room Temperature

Tested by a 10km optical fiber

2m optical fiber (1day)

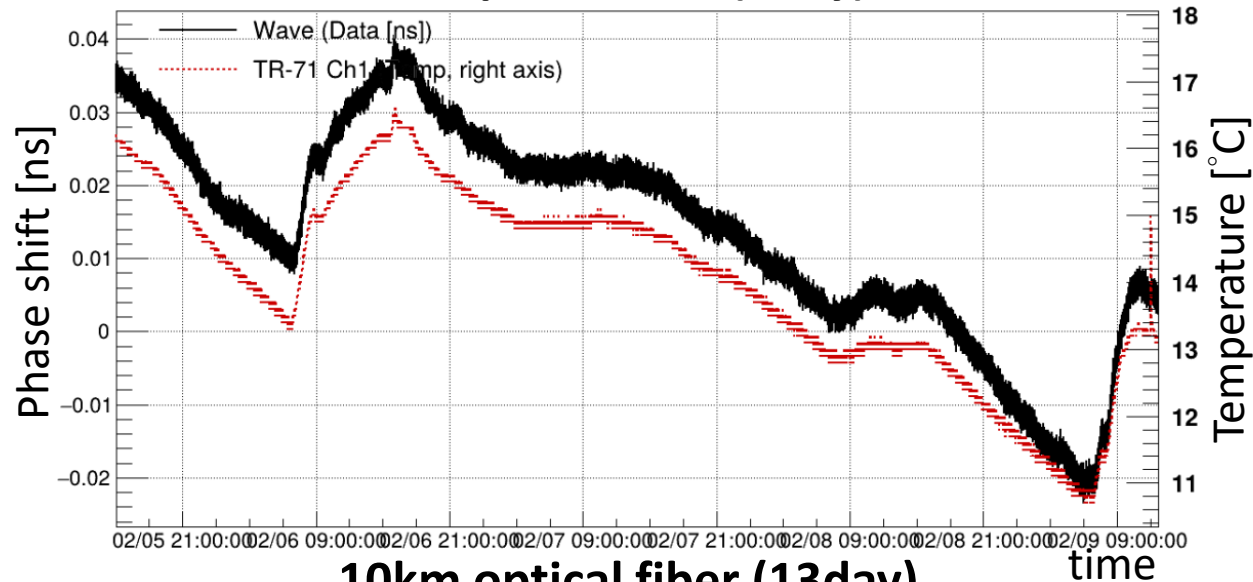

- Red : room temperature
- Block : measured phase shift

- The measured **phase shift** clearly **tracks** the **room temperature** variation.

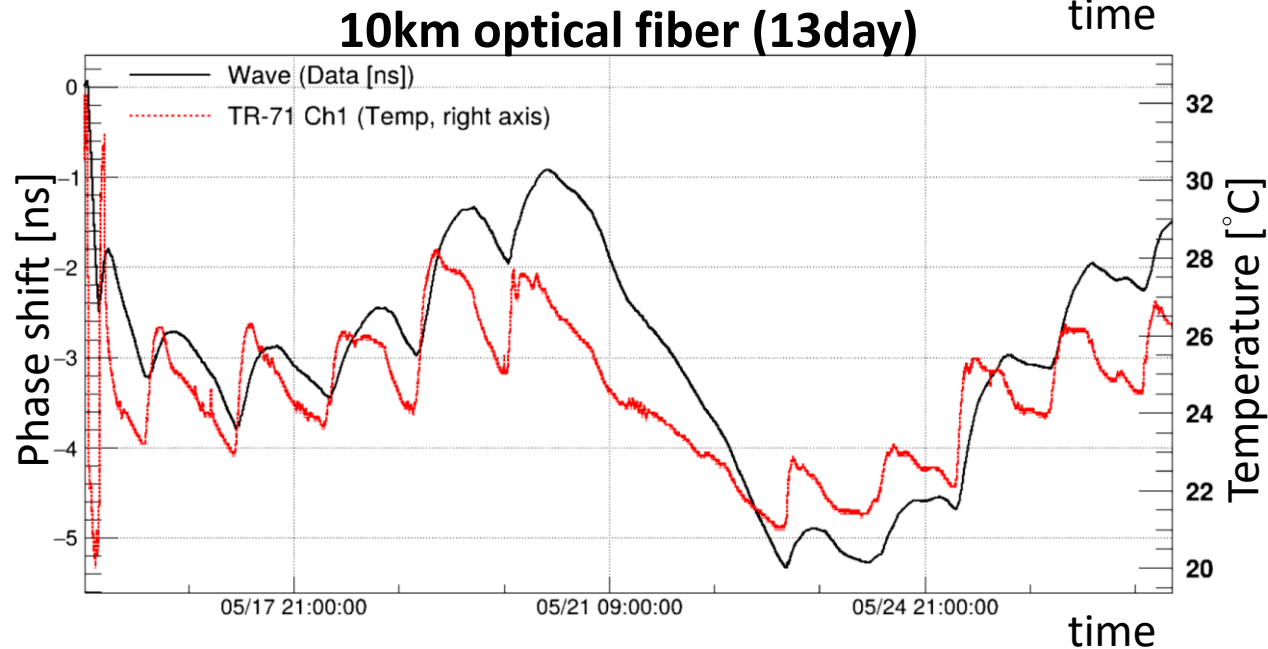

- The phase shift of the 10km optical fiber are significantly larger than the 2m one.

Measured signals on Oscilloscope

Tested by a 10km optical fiber

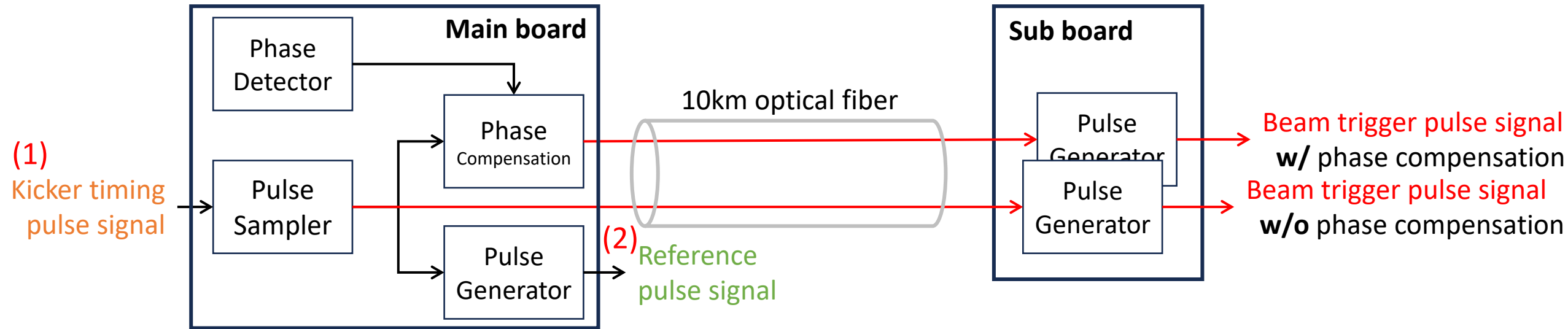

(1) Trigger the **kicker timing pulse signal**

- Evaluate the pulse signal transmission performance.

(2) Trigger the **reference pulse signal**

- Evaluate the phase compensation performance.
- Suppress sampling-timing uncertainty.

Result of Time Synchronization System

Tested by a 10km optical fiber

1) Transmission latency & Timing accuracy :

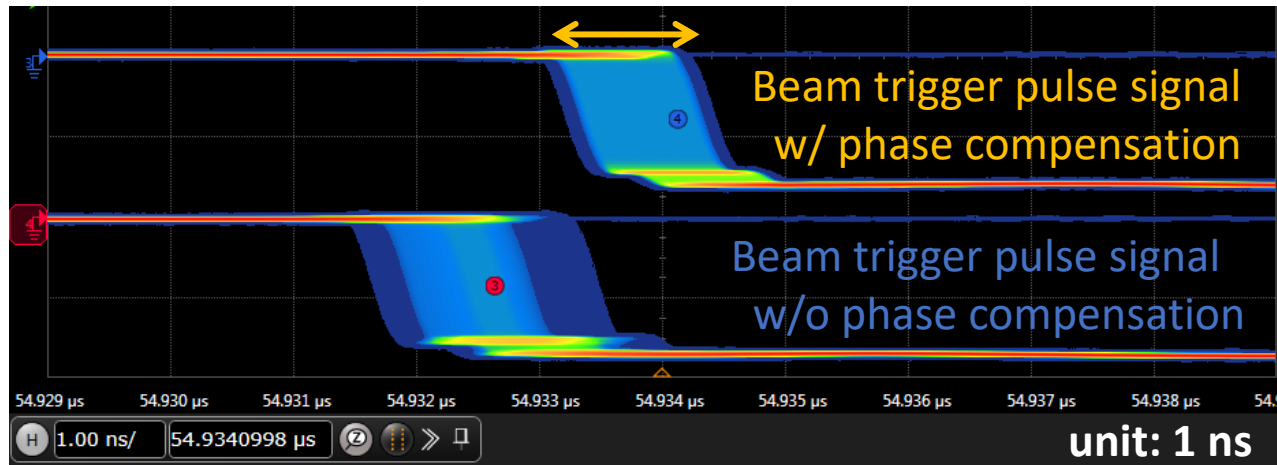

- Kicker timing pulse signal as trigger
- Transmission latency: (requirement <1 ms)
 - Time interval: 54.934 μ s (with extra latency of 5 μ s)
- Timing accuracy:
 - Range (Max-Min): 1.223 ns

3) Stability:

- Testing time \approx 11 days
- Room temperature variation \approx 12 $^{\circ}$ C
- Clock phase shift \approx 5 ns
- The MIKUMARI RX on the main board maintains the sampling point at the center based on the measured phase shift.

- # of transmitted pulse signal: 9,352,060,226
- No trigger loss was detected.
- Probability of trigger loss: $< 3.2 \times 10^{-10}$ @95%CL

2) Phase compensation performance:

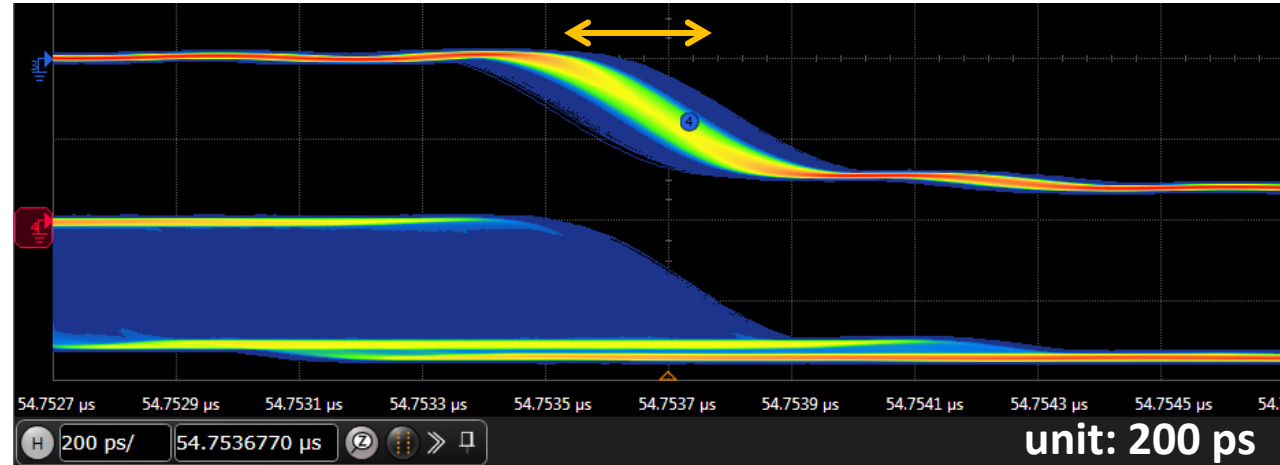

- Reference pulse signal as trigger
- Phase compensation performance :
 - Range (Max-Min): 287.754 ps
 - Std Dev: 34.996 ps

The testing results
confirmed requirements.

Conclusion

Development of the new pulse signal transmission method

- **Motivation:** replace the current timing distribution system of T2K experiment at J-PARC site.
- **Principle: digitize the analog pulse signal** for transmission.
 - (1) Main board: digitalize the pulse signal.
 - (2) MIKUMARI link protocol: transmit the leading-edge timing of pulse signal.
 - (3) Sub board: generate the pulse signal at the corresponding timing.
- **Advantage:**
 - (1) Enables flexible transmission of multi-channel pulse signals or additional information via a duplex optical fiber.
 - (2) Mitigates the drift of the pulse signal caused by ambient temperature variation.
- **Test results** using a 10-km optical fiber:
 - Timing accuracy : 1.22 ns - Transmission latency: fixed 54.92 μs (with extra latency of 5 μs)
 - Probability of trigger loss: $< 3.2 \times 10^{-10}$ @95%CL
- ➔ Confirmed requirements.
- **Future:** implement it for the timing distribution system of Hyper-K experiment.

Backup

MIKUMARI

Clock distribution system based on clock-duty-cycle-modulation (CDCM)

- MIKUMARI link

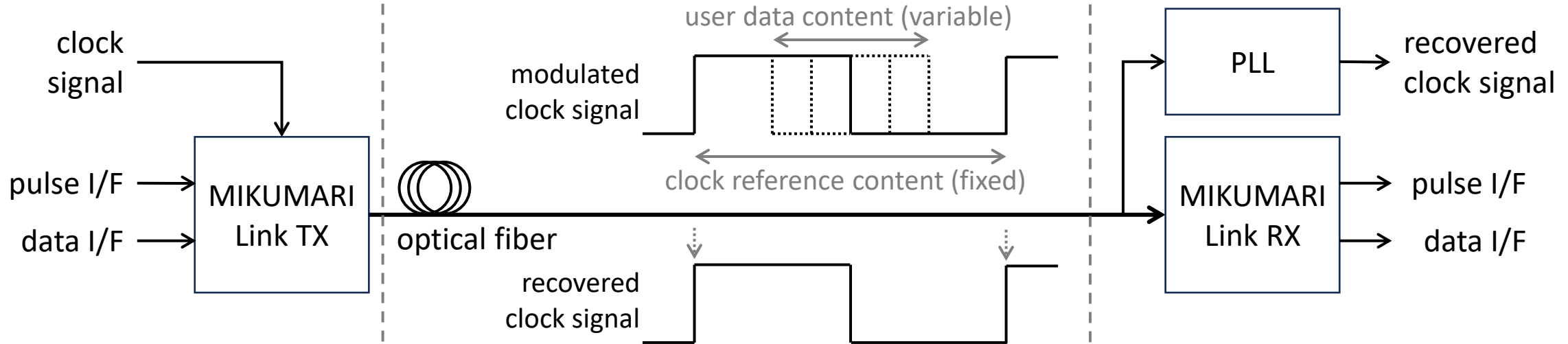

- MIKUMARI modulated clock signal:

- characteristic

- fixed leading-edge interval carrying clock reference.
- variable duty cycle embedding user data.

- transmitter

- modulated by **OSERDES** (Serializer) primitive of FPGA.

- receiver

- used as the **PLL** (Phase-Locked Loop) reference to recover clock signal.
- decoded by **IDELAY** and **ISERDES** (Deserializer) primitive of FPGA.

- MIKUMARI link interface (I/F):

- pulse I/F

- 3-bit data width.

- **fixed transmission latency.**

- data I/F

- **DC-balance data frame** (a few 8-bit characters)
- transmission latency **with a few uncertainty**

Method of Time Synchronization System (2)

Sample and Generate the Kicker Timing

- I/O SERDES

- Serial/Deserial Converter

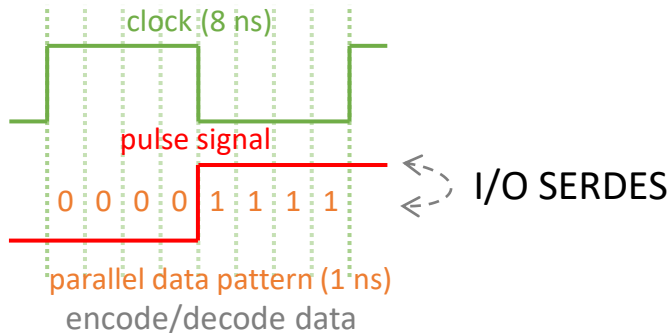

- Converting ratio: 1-to-8

- Timing resolution: 8 ns \rightarrow 1 ns

- Pulse Sampler (1ns TDC)

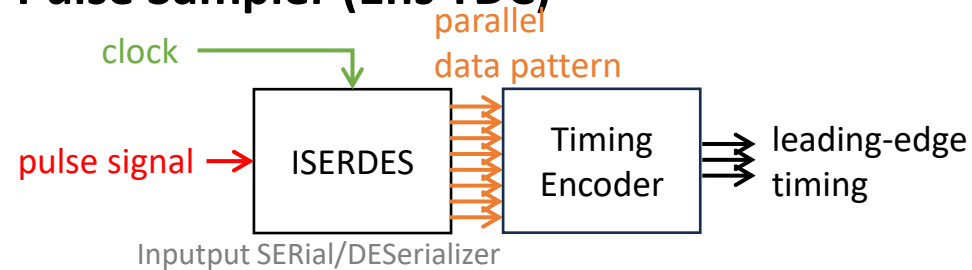

- ISERDES samples the data pattern of pulse signal.

- Timing encoder converts the data pattern to leading-edge timing

- Pulse Generator

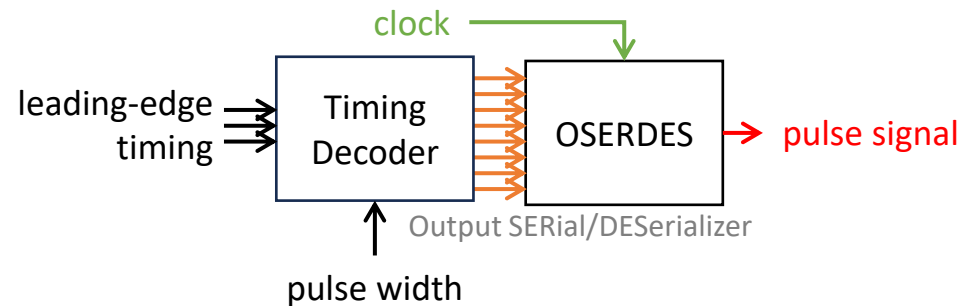

- Only the leading-edge timing is delivered by MIKUMARI link protocol.

- Timing decoder generates the data pattern by the leading-edge timing and pulse width parameter.

- OSERDES generates the pulse signal.

Extra Fixed Latency

To ensure timely pulse generation.

Note:

- 1) The latency of the data I/F are longer than the pulse I/F, and has a **small uncertainty**.
- 2) The pulse I/F has higher **priority** than the data I/F.

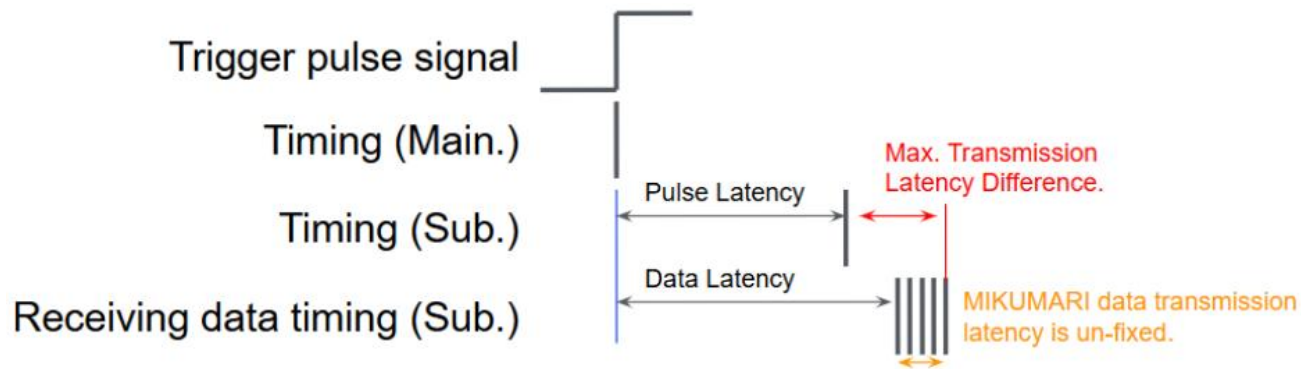

- To ensure timely pulse generation, the added extra fixed latency must be enough long.
- **Larger than the maximum of transmission latency difference** between the MIKUMARI data and pulse I/F.

- Transmission latency difference of MIKUMARI I/F

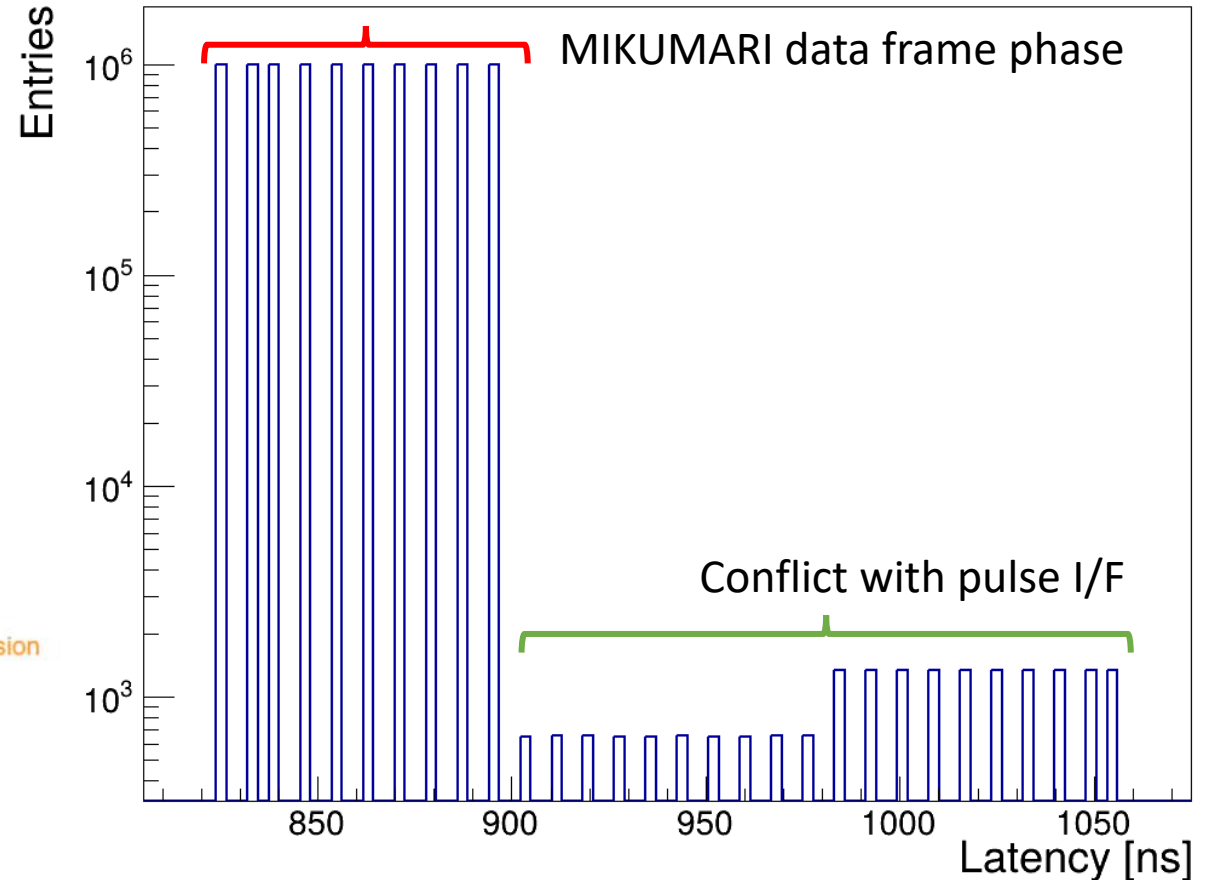

- The maximum of transmission latency difference is acceptable.
- **Extract fixed latency > 1060 ns**

A Main Electronics for Network Oriented Trigger-less Data Acquisition System

- The AMANEQ is generic electronic board for StrDAQ system.
- By modifying the FPGA firmware and exchanging the mezzanine card, the AMANEQ can achieve various purposes.

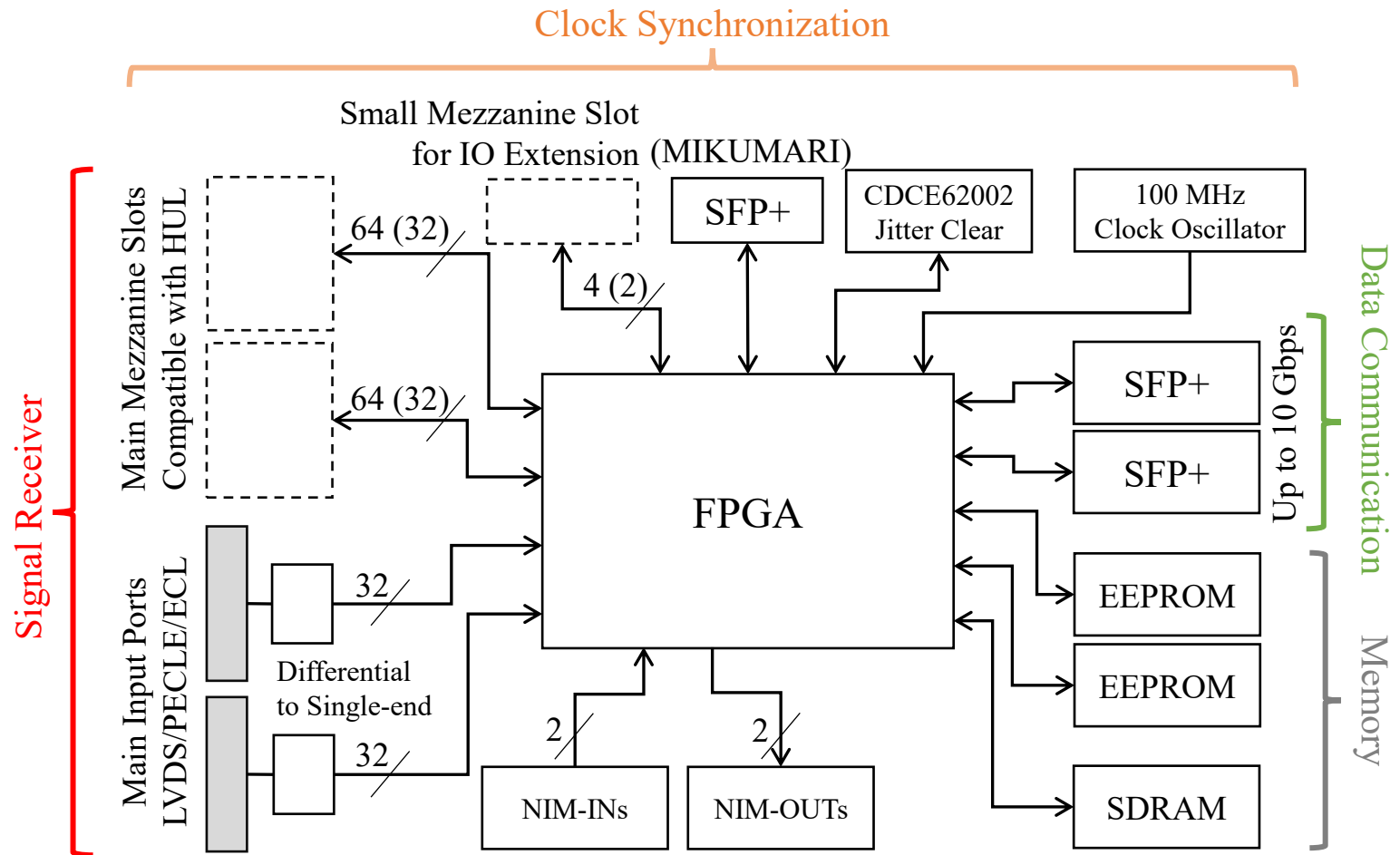
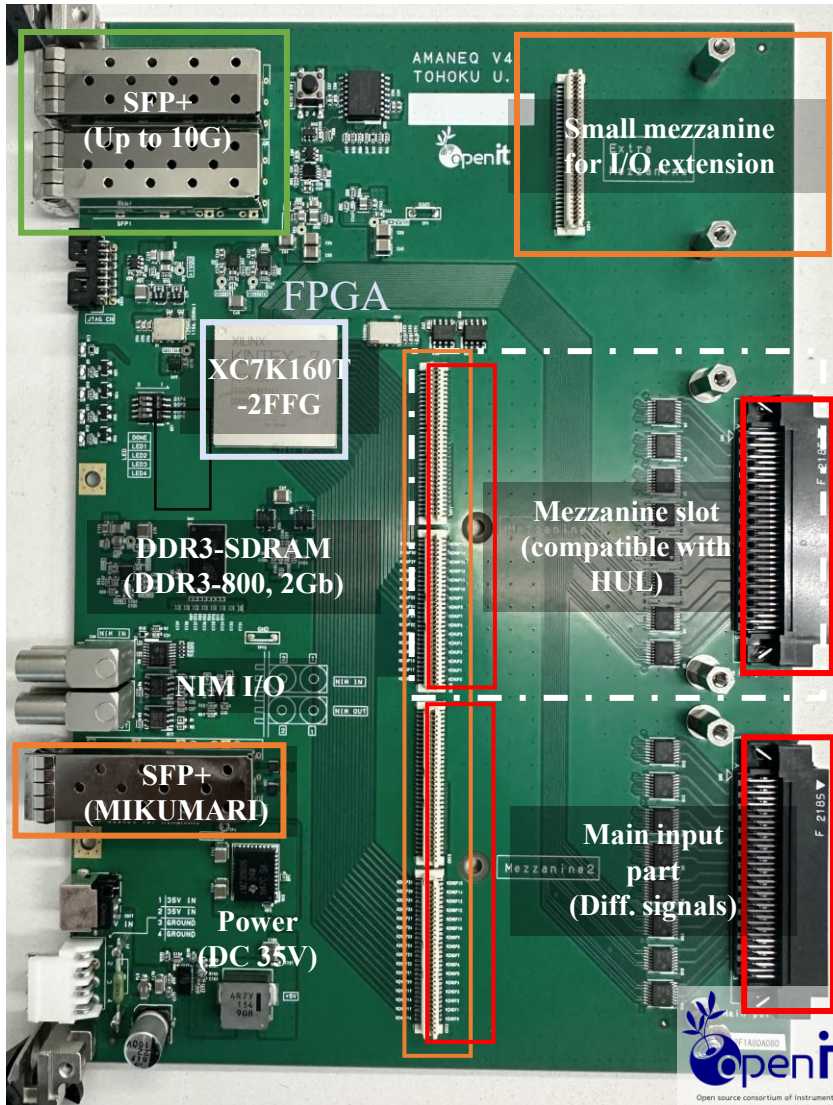

Evaluate DDMTD phase measurement

By ODELAY of MIKUMARI TX on sub board

