

# Real-time DAQ System for Muon-Spin Spectroscopy

---

MARIUS SNELLA KÖPPEL ON BEHALF OF  
MUSIP COLLABORATION

25TH IEEE REAL TIME CONFERENCE  
25.05.2026 ELBA

PAUL SCHERRER INSTITUT



**ETH** zürich

# TABLE OF CONTENTS

The background image shows a laboratory environment. A prominent feature is a large, thick blue cable bundle that is organized and held together by several white paper labels. One label clearly shows '3-A', and another shows '1-B'. The cables are connected to a metal structure, possibly part of a detector or data acquisition system. In the background, there are various pieces of equipment, including what looks like a control panel or a rack of modules, and a large cylindrical object, possibly a component of a particle accelerator or detector.

01 | MuSR at PSI

02 | HV-MAPS & DAQ

03 | Results

# **$\mu$ SR Principle**

**Muon Spin Rotation/Relaxation/Resonance**

# **$\mu$ SR Principle**

## **Muon Spin Rotation/Relaxation/Resonance**

- **Material Science Technique**
- **Measure local magnetic fields**

# **$\mu$ SR Principle**

## **Muon Spin Rotation/Relaxation/Resonance**

- **Material Science Technique**
- **Measure local magnetic fields**
- **Battery materials / Superconducting materials**

# **$\mu$ SR Principle**

## **Muon Spin Rotation/Relaxation/Resonance**

- **Material Science Technique**
- **Measure local magnetic fields**
- **Battery materials / Superconducting materials**

**1. Implant spin polarized muons in sample material**

# **$\mu$ SR Principle**

## **Muon Spin Rotation/Relaxation/Resonance**

- **Material Science Technique**
- **Measure local magnetic fields**
- **Battery materials / Superconducting materials**

**1. Implant spin polarized muons in sample material**

**2. Muon spin evolves in internal and external magnetic field**

# **$\mu$ SR Principle**

## **Muon Spin Rotation/Relaxation/Resonance**

- **Material Science Technique**
- **Measure local magnetic fields**
- **Battery materials / Superconducting materials**

- 1. Implant spin polarized muons in sample material**
- 2. Muon spin evolves in internal and external magnetic field**
- 3. Measure anisotropic decay to positrons**

# $\mu$ SR Principle

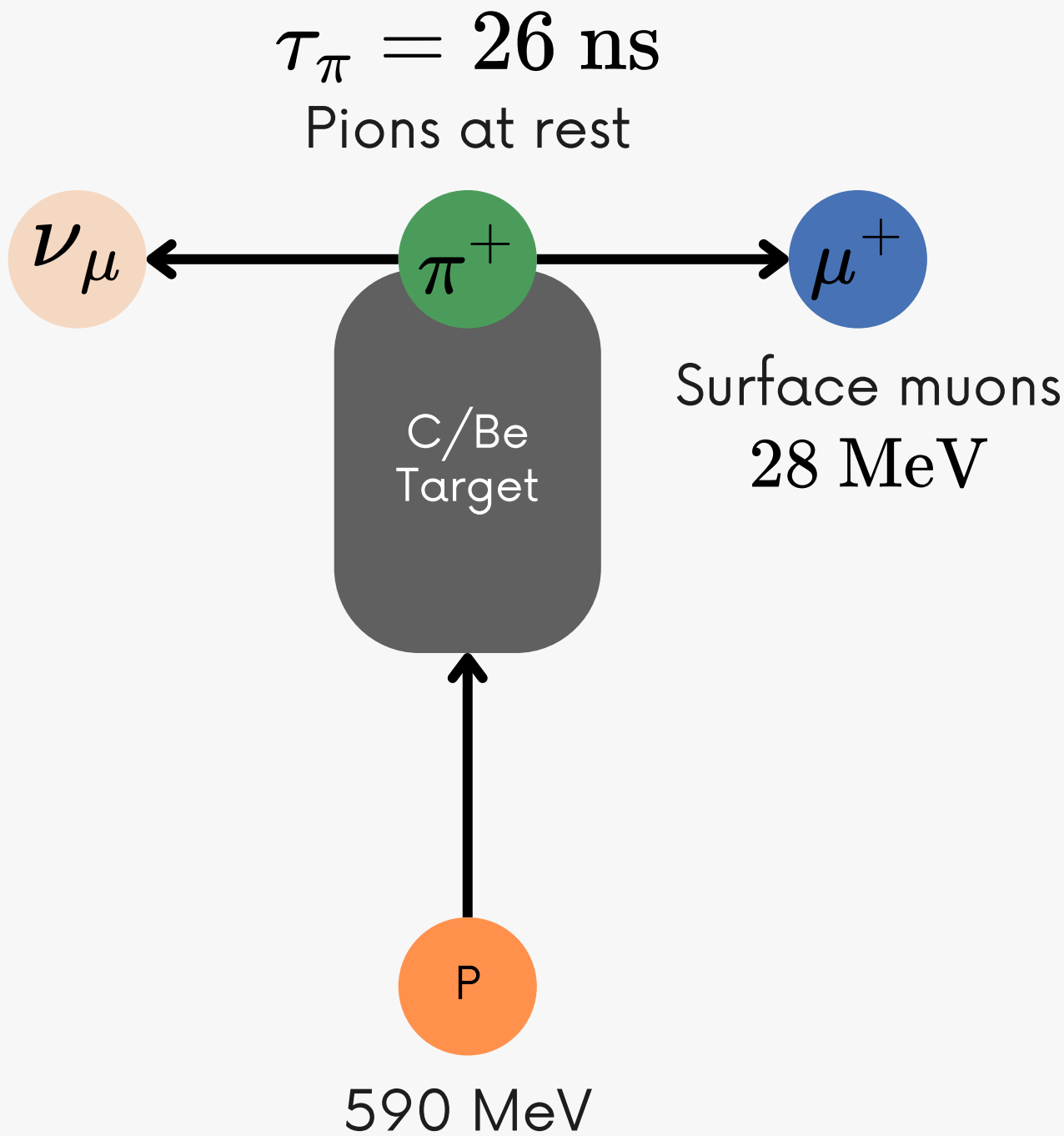

# $\mu$ SR Principle

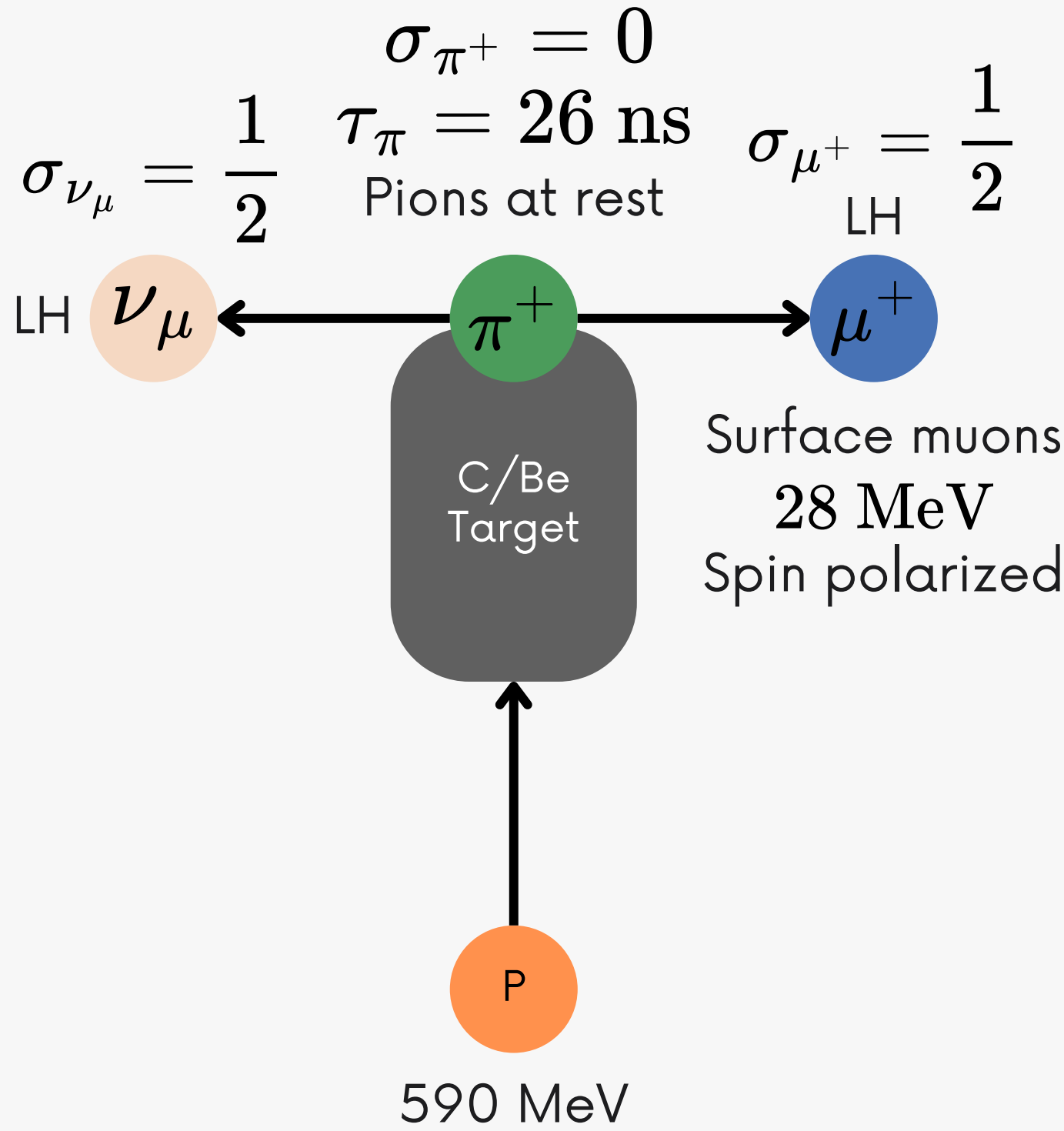

# $\mu$ SR Principle

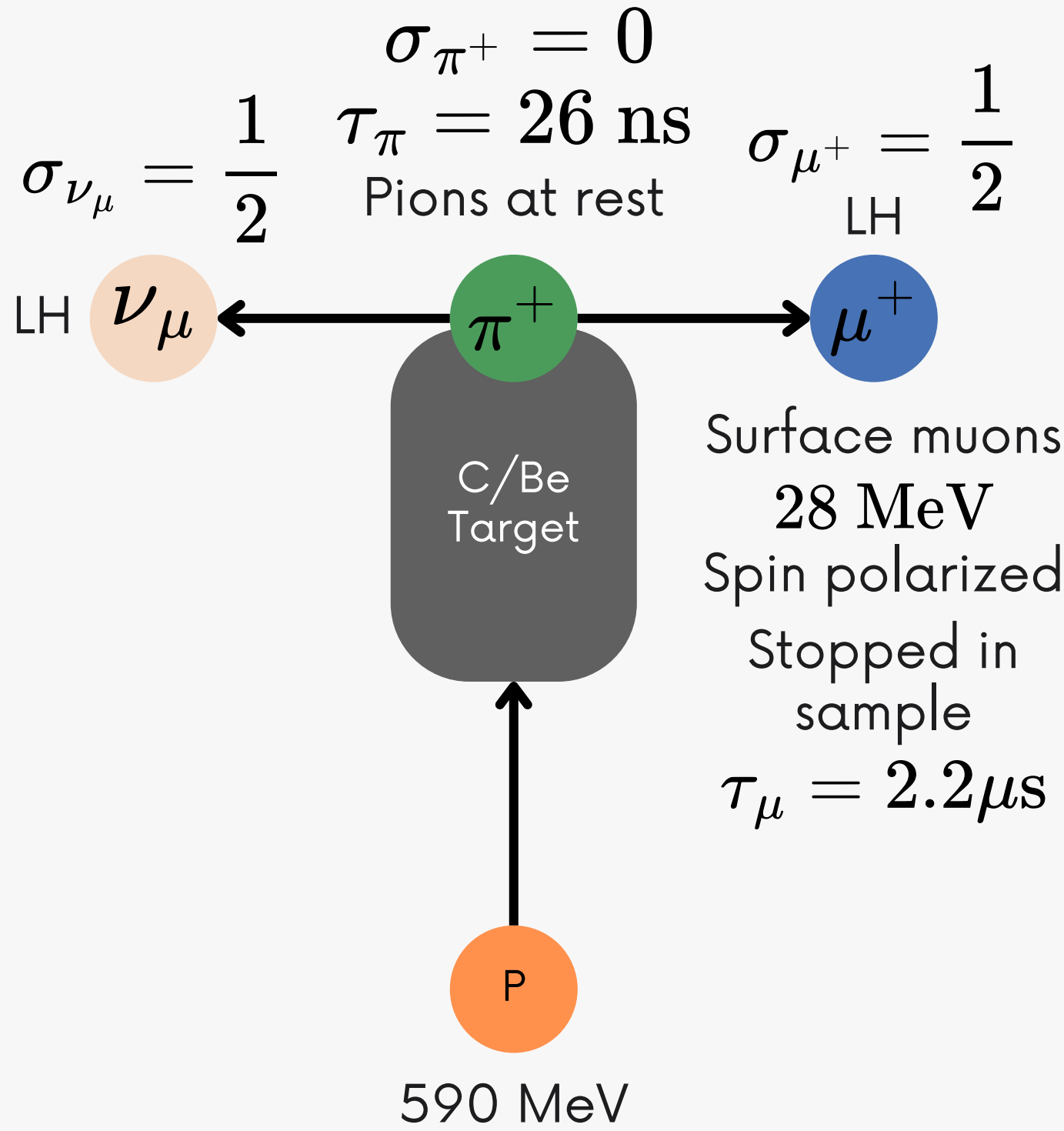

# $\mu$ SR Principle

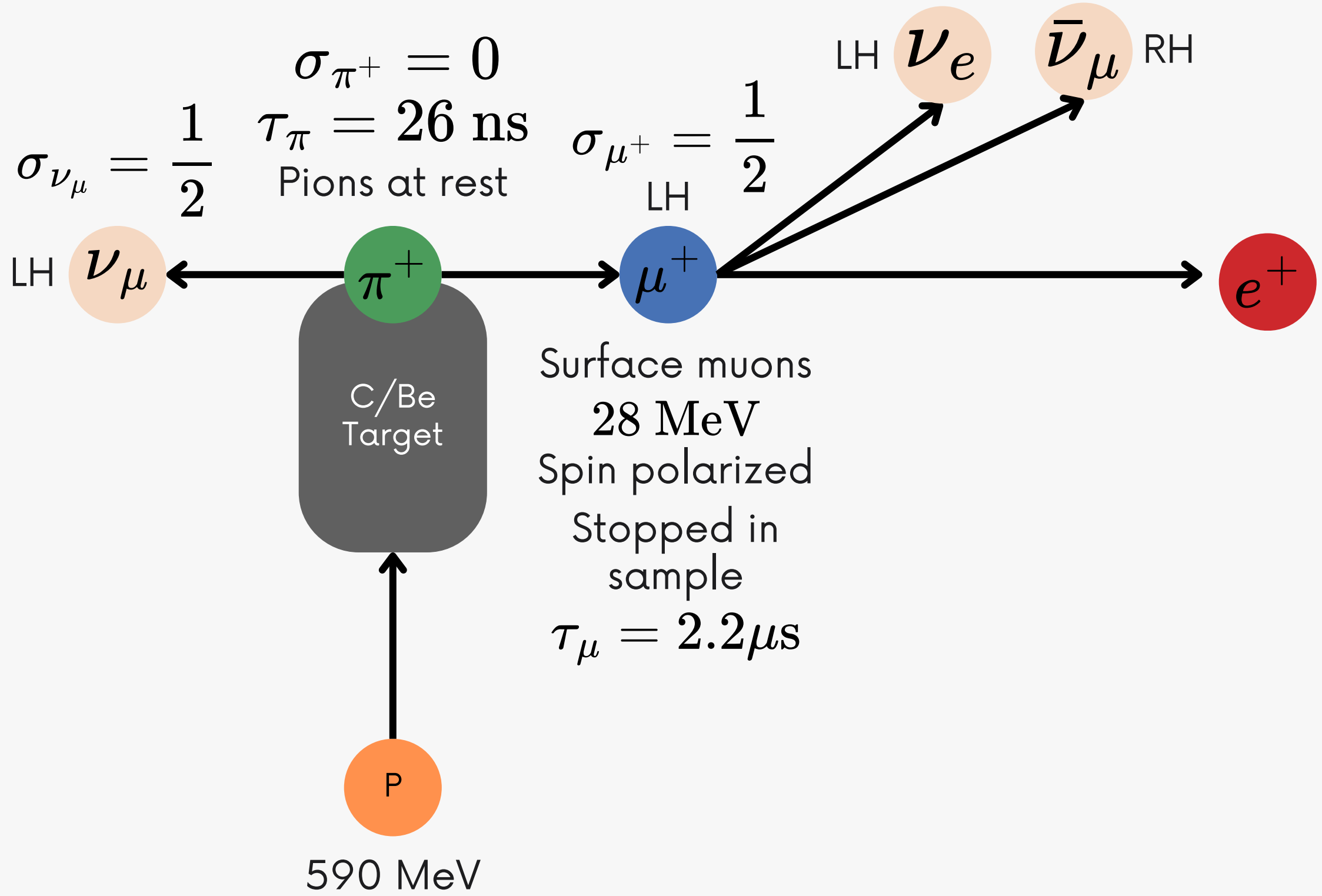

# $\mu$ SR Principle

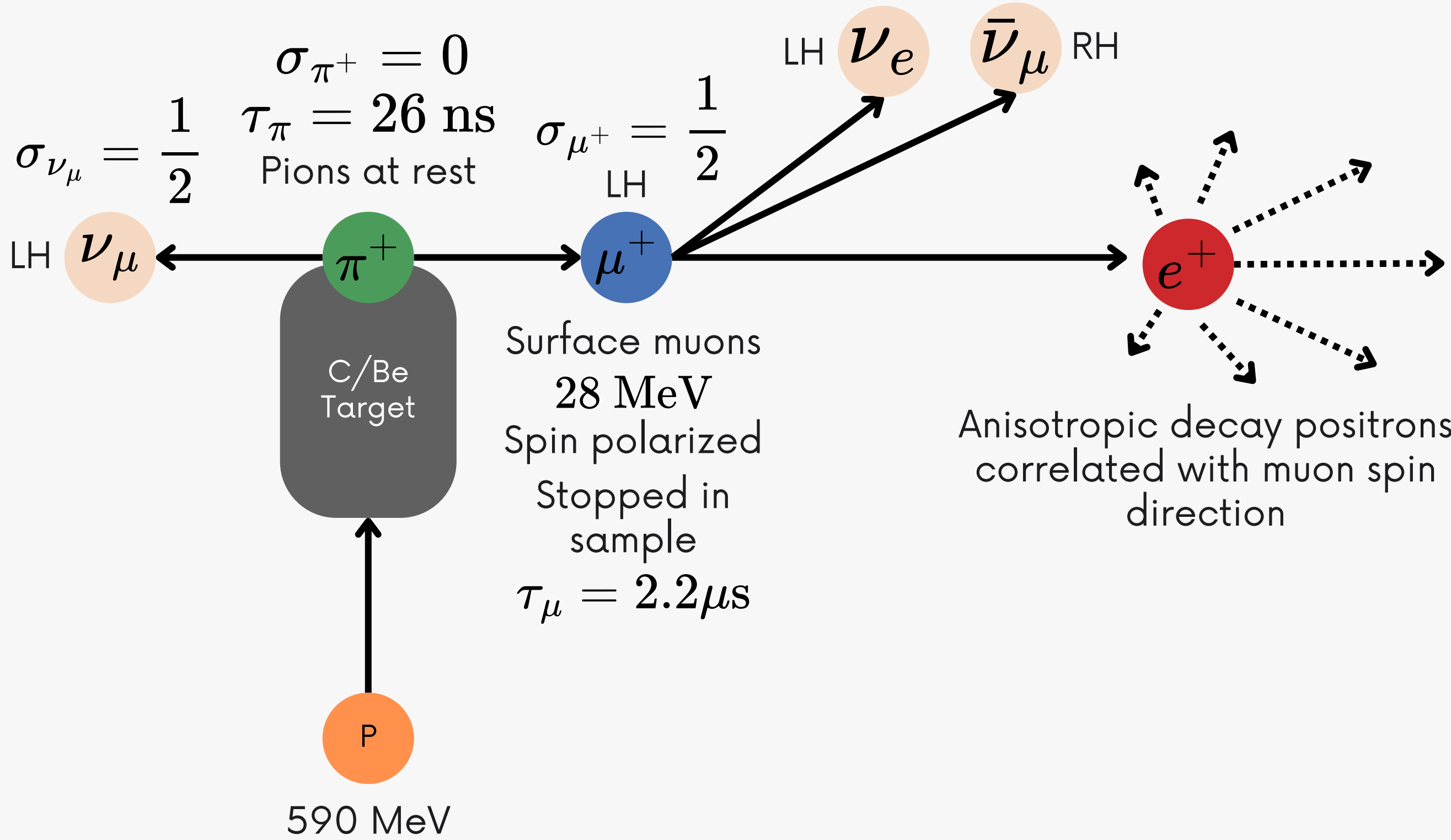

# $\mu$ SR Principle

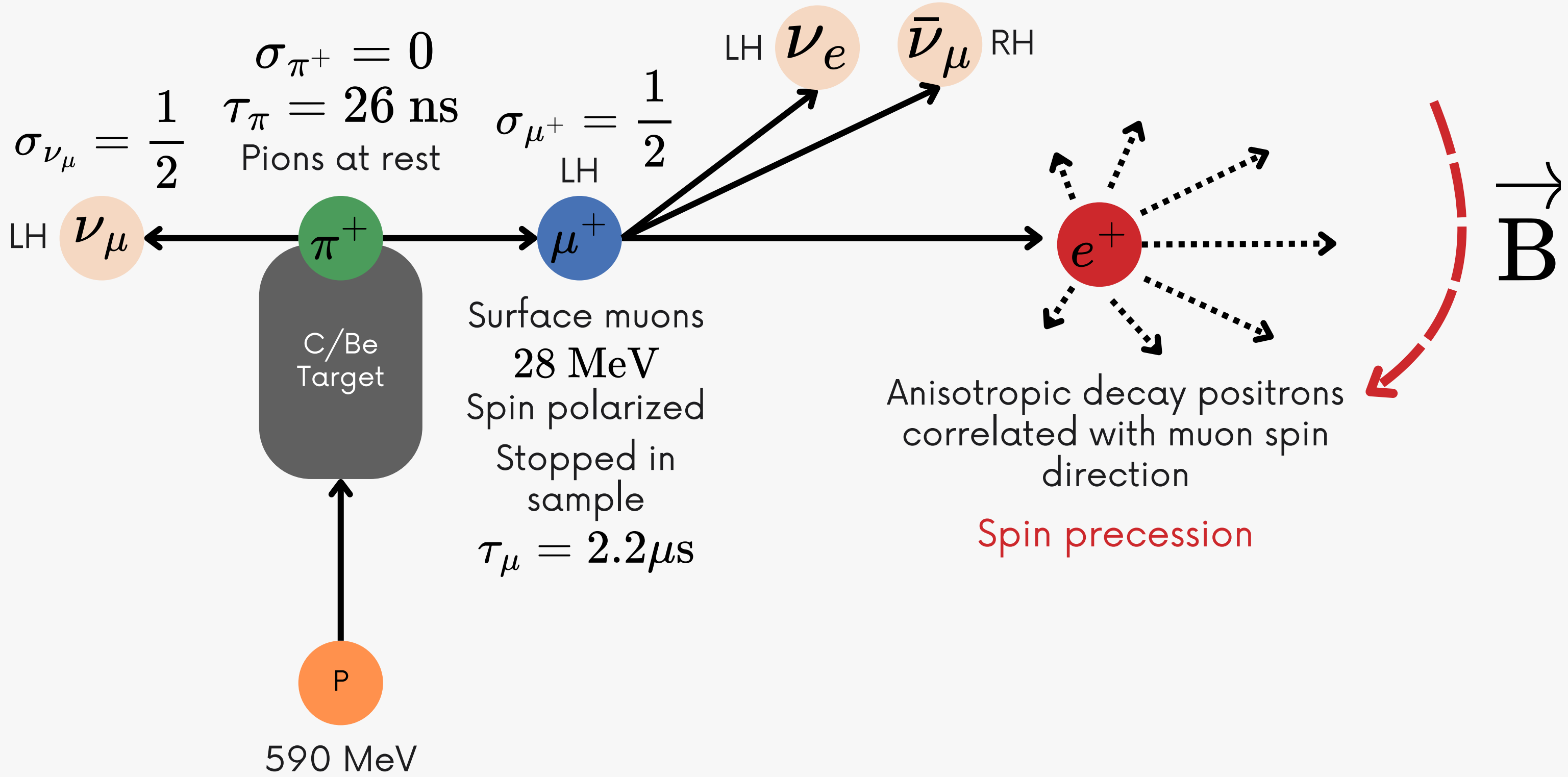

# μSR Principle

$$N(t) = N_{bkg} + N_0 \cdot e^{-\frac{t}{\tau_\mu}} \cdot (1 + A_{sym} \cdot e^{-t \cdot lam} \cdot \cos(2 \cdot \pi \cdot f \cdot t + \varphi))$$

$N_{bkg}$ : Background  
 $N_0 \cdot e^{-\frac{t}{\tau_\mu}}$ : Exponential muon decay  
 $A_{sym}$ : Intrinsic asymmetry parameter of weak decay  
 $e^{-t \cdot lam}$ : Relaxation function of temporal decrease of the polarization degree  
 $\cos(2 \cdot \pi \cdot f \cdot t + \varphi)$ : Angle between positron and muon spin direction  
 $f$ : Larmor frequency of muon spin precession

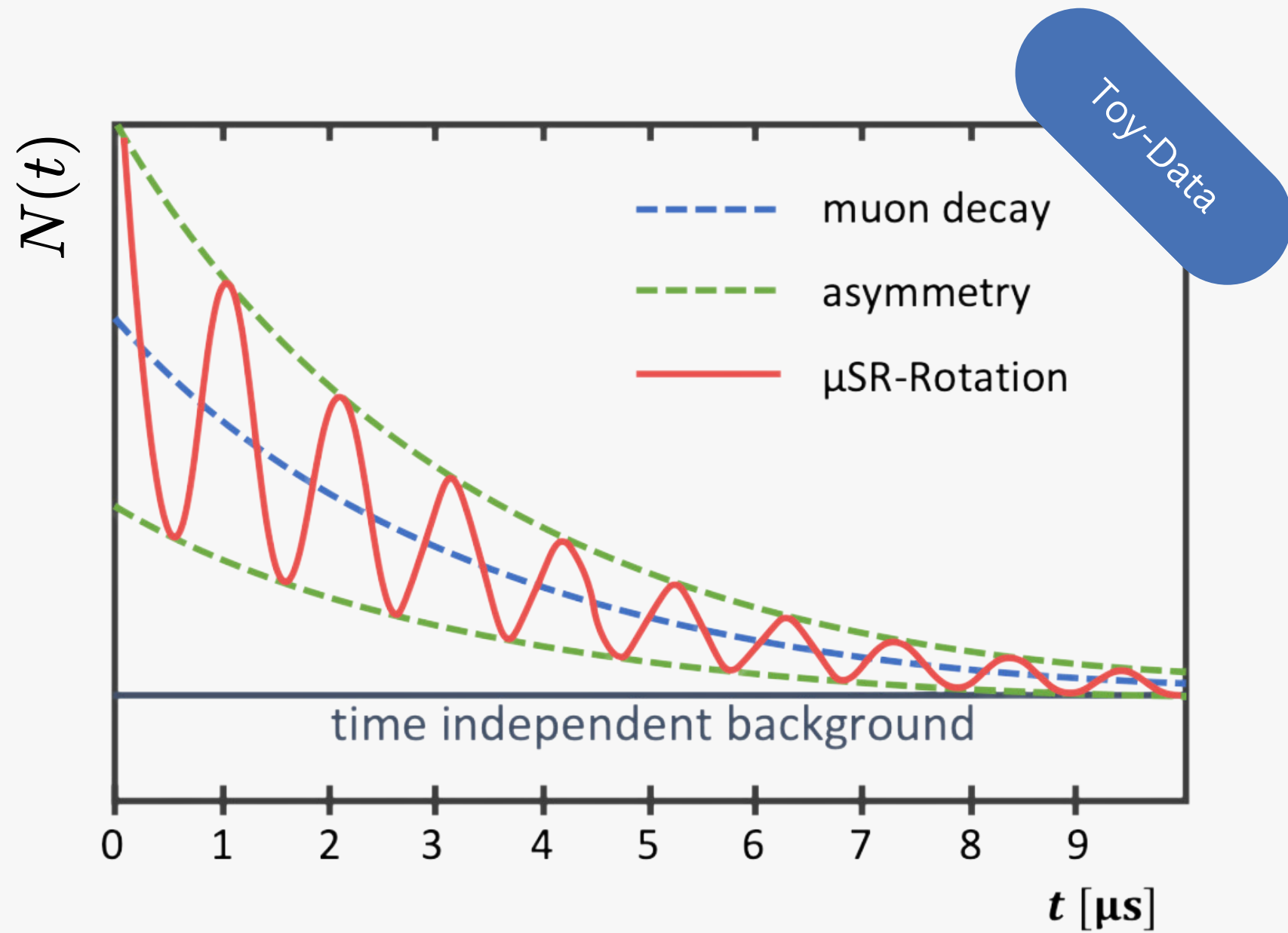

## Positron detector

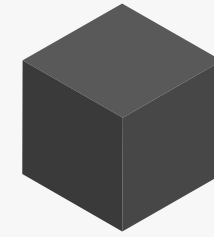

$2 \cdot \pi \cdot f$   $\vec{B}$

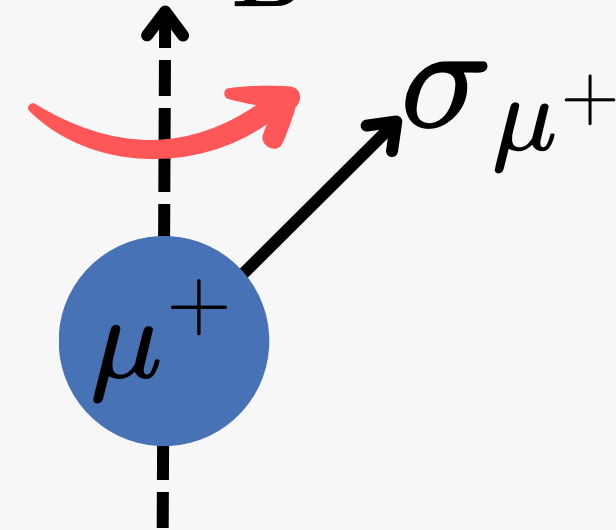

# $\mu$ SR Principle

$$N(t) = N_{bkg} + N_0 \cdot e^{-\frac{t}{\tau_\mu}} \cdot (1 + A_{sym} \cdot e^{-t \cdot lam} \cdot \cos(2 \cdot \pi \cdot f \cdot t + \varphi))$$

$N_{bkg}$ : Background  
 $N_0 \cdot e^{-\frac{t}{\tau_\mu}}$ : Exponential muon decay  
 $A_{sym}$ : Intrinsic asymmetry parameter of weak decay  
 $e^{-t \cdot lam}$ : Relaxation function of temporal decrease of the polarization degree  
 $\cos(2 \cdot \pi \cdot f \cdot t + \varphi)$ : Angle between positron and muon spin direction  
 $f$ : Larmor frequency of muon spin precession

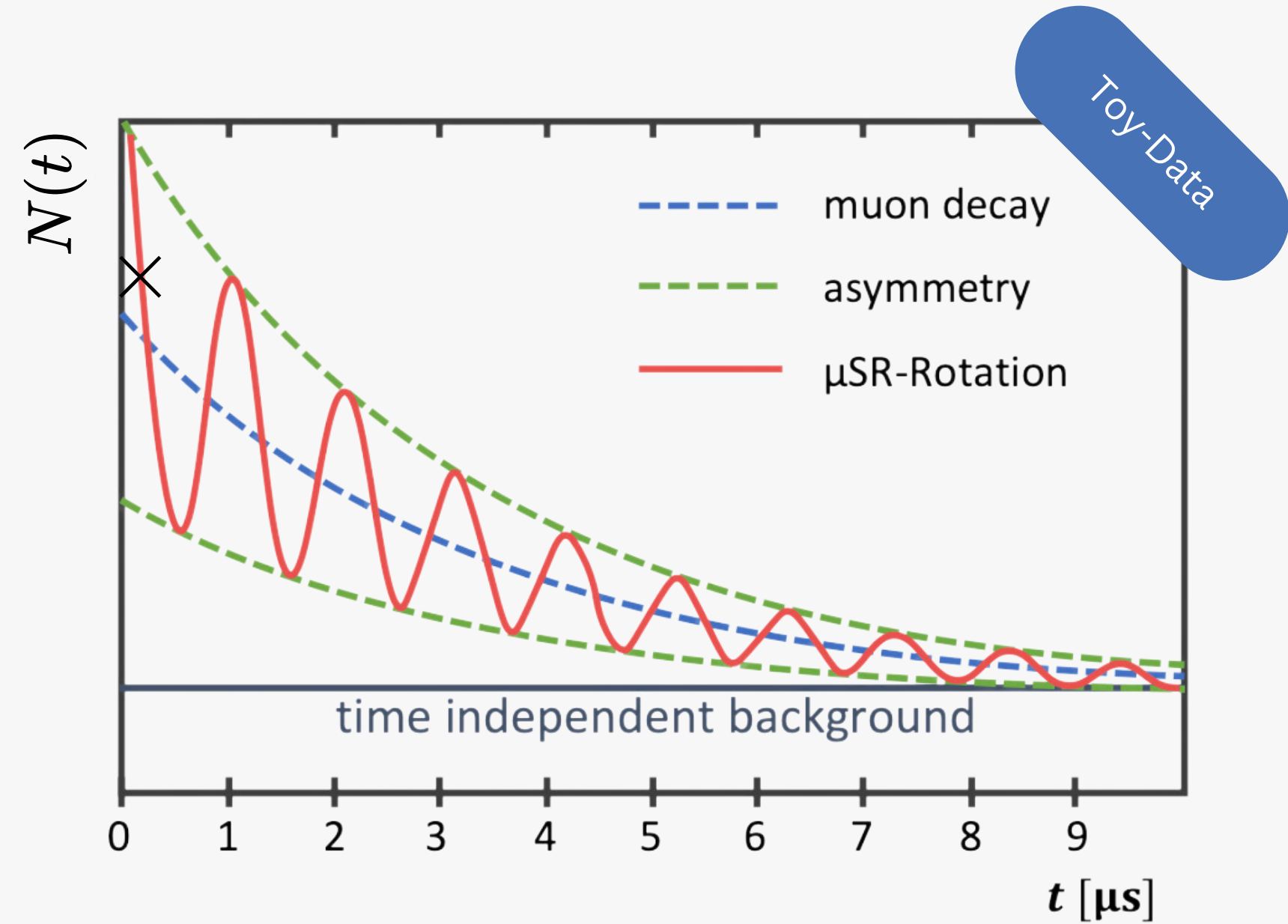

## Positron detector

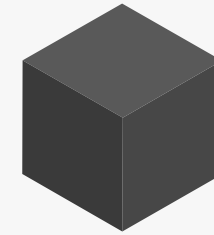

$2 \cdot \pi \cdot f$   $\vec{B}$

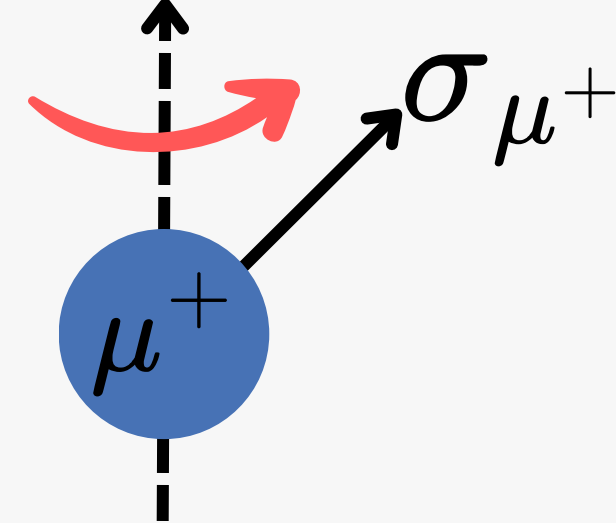

# μSR Principle

$$N(t) = N_{bkg} + N_0 \cdot e^{-\frac{t}{\tau_\mu}} \cdot (1 + A_{sym} \cdot e^{-t \cdot lam} \cdot \cos(2 \cdot \pi \cdot f \cdot t + \varphi))$$

$N_{bkg}$ : Background  
 $N_0 \cdot e^{-\frac{t}{\tau_\mu}}$ : Exponential muon decay  
 $A_{sym}$ : Intrinsic asymmetry parameter of weak decay  
 $e^{-t \cdot lam}$ : Relaxation function of temporal decrease of the polarization degree  
 $\cos(2 \cdot \pi \cdot f \cdot t + \varphi)$ : Angle between positron and muon spin direction (Larmor frequency of muon spin precession)

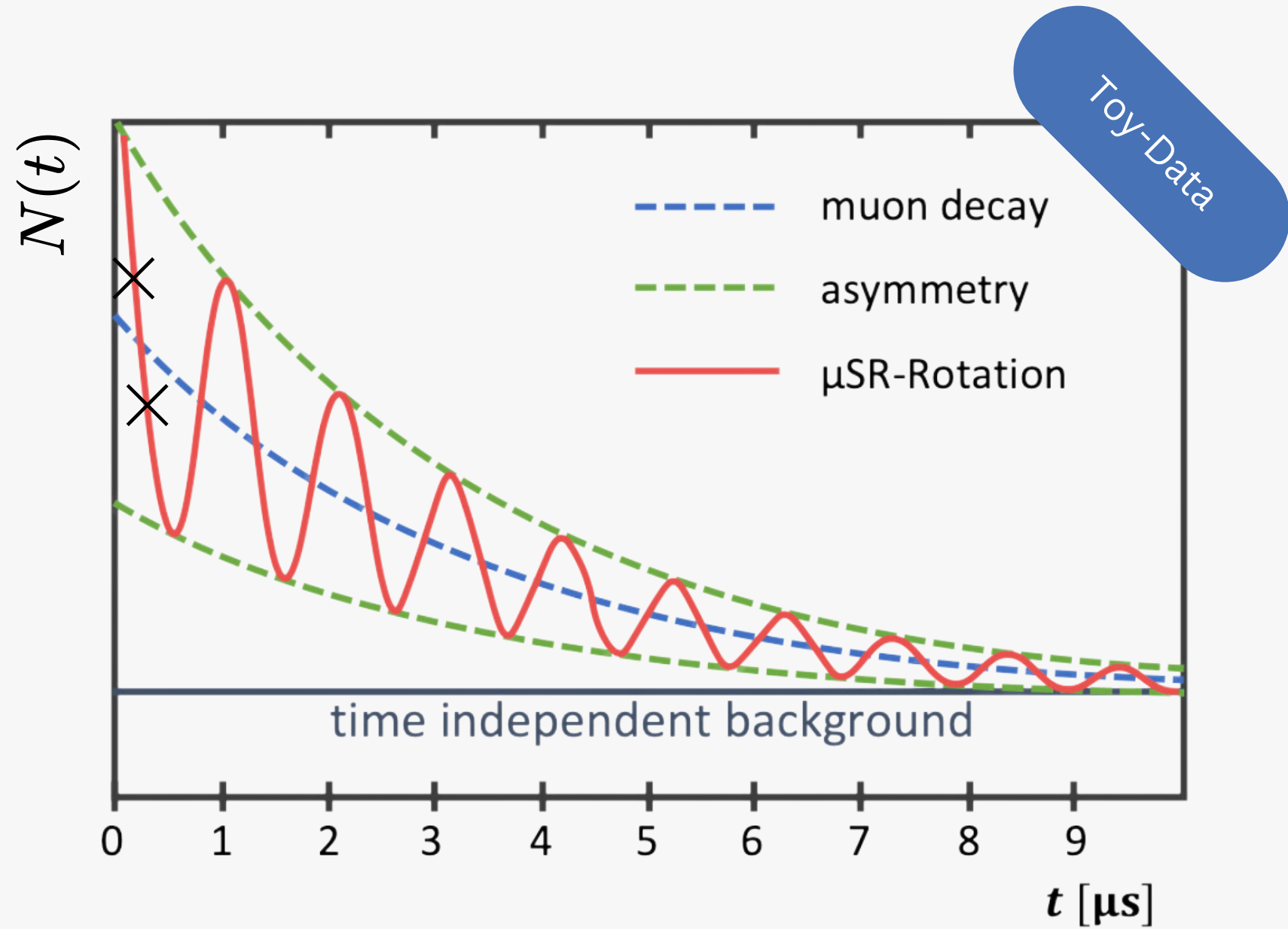

## Positron detector

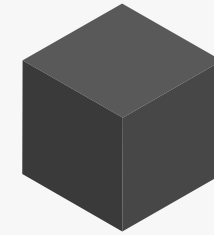

$2 \cdot \pi \cdot f$   $\vec{B}$

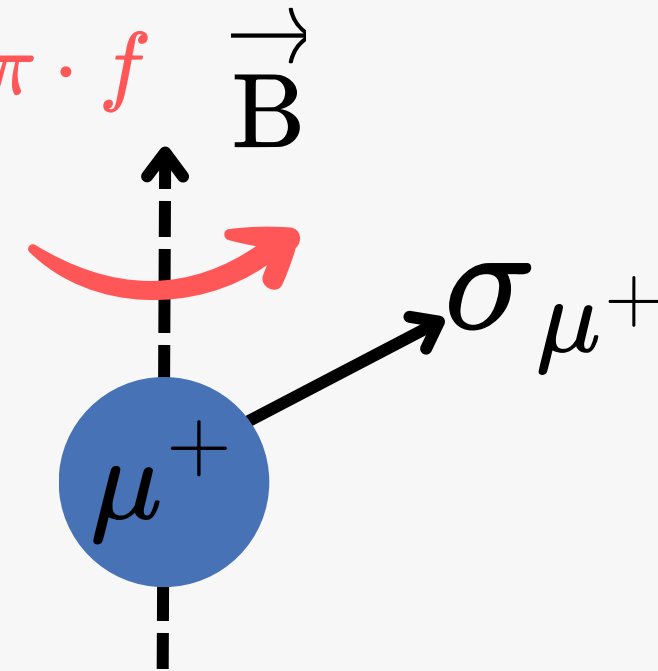

# $\mu$ SR Principle

$$N(t) = N_{bkg} + N_0 \cdot e^{-\frac{t}{\tau_\mu}} \cdot (1 + A_{sym} \cdot e^{-t \cdot lam} \cdot \cos(2 \cdot \pi \cdot f \cdot t + \varphi))$$

$N_{bkg}$ : Background  
 $N_0 \cdot e^{-\frac{t}{\tau_\mu}}$ : Exponential muon decay  
 $A_{sym}$ : Intrinsic asymmetry parameter of weak decay  
 $e^{-t \cdot lam}$ : Relaxation function of temporal decrease of the polarization degree  
 $\cos(2 \cdot \pi \cdot f \cdot t + \varphi)$ : Angle between positron and muon spin direction (Larmor frequency of muon spin precession)

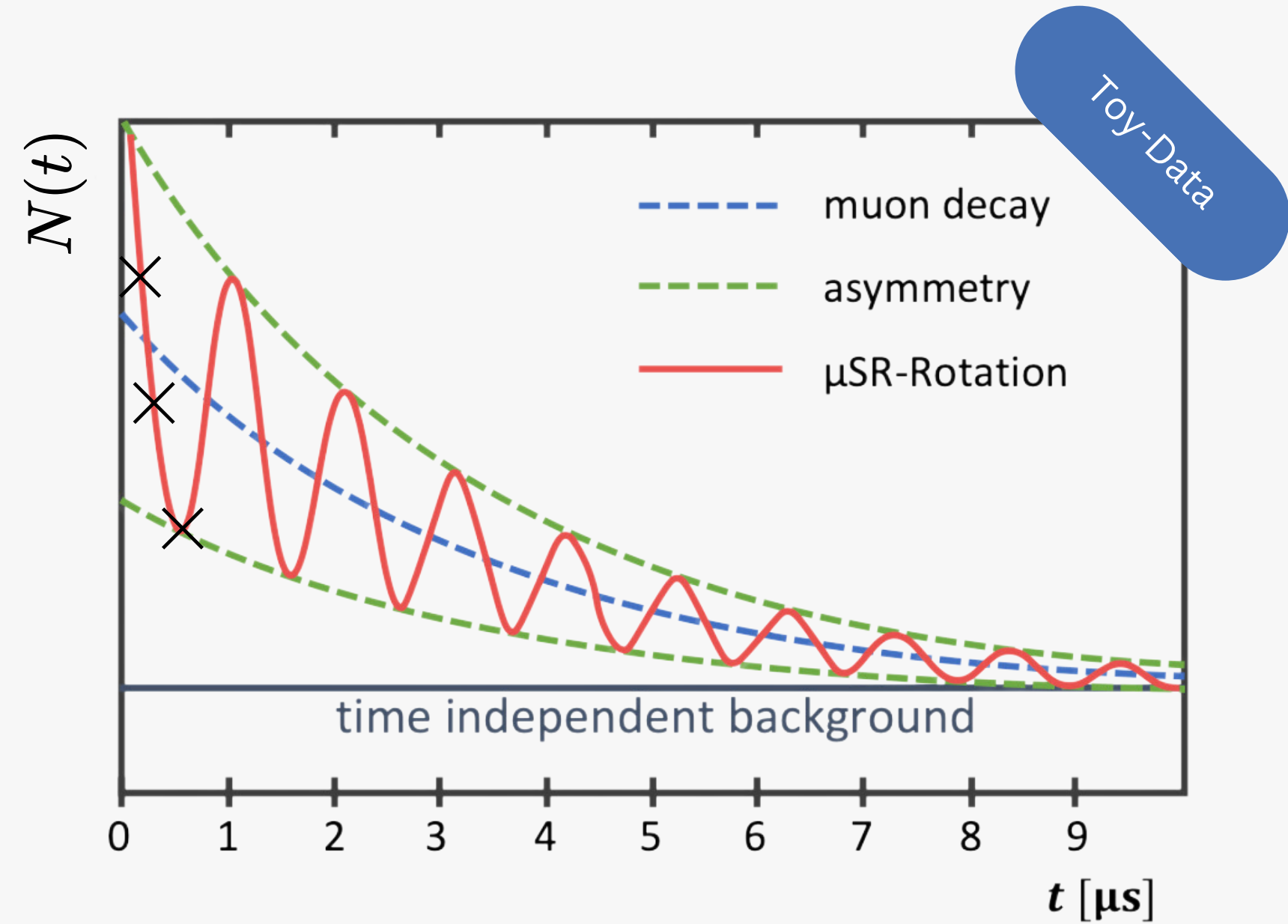

## Positron detector

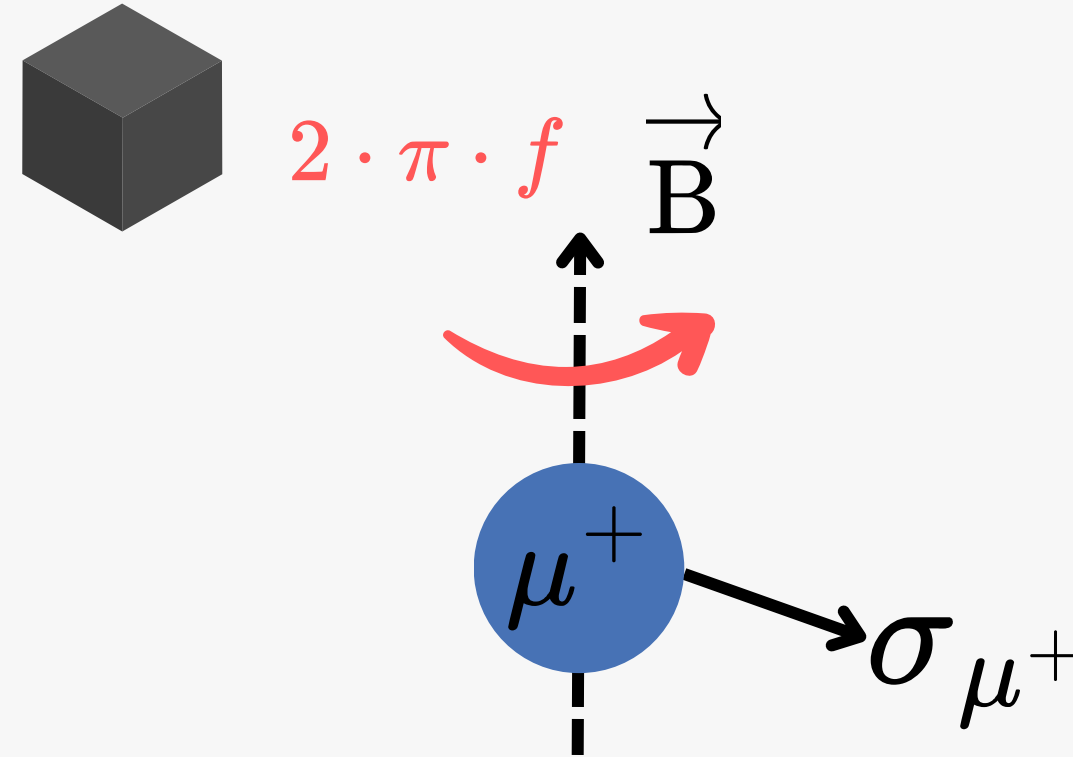

# μSR Principle

$$N(t) = N_{bkg} + N_0 \cdot e^{-\frac{t}{\tau_\mu}} \cdot (1 + A_{sym} \cdot e^{-t \cdot lam} \cdot \cos(2 \cdot \pi \cdot f \cdot t + \varphi))$$

$N_{bkg}$ : Background  
 $N_0 \cdot e^{-\frac{t}{\tau_\mu}}$ : Exponential muon decay  
 $A_{sym}$ : Intrinsic asymmetry parameter of weak decay  
 $e^{-t \cdot lam}$ : Relaxation function of temporal decrease of the polarization degree  
 $\cos(2 \cdot \pi \cdot f \cdot t + \varphi)$ : Angle between positron and muon spin direction  
 $f$ : Larmor frequency of muon spin precession

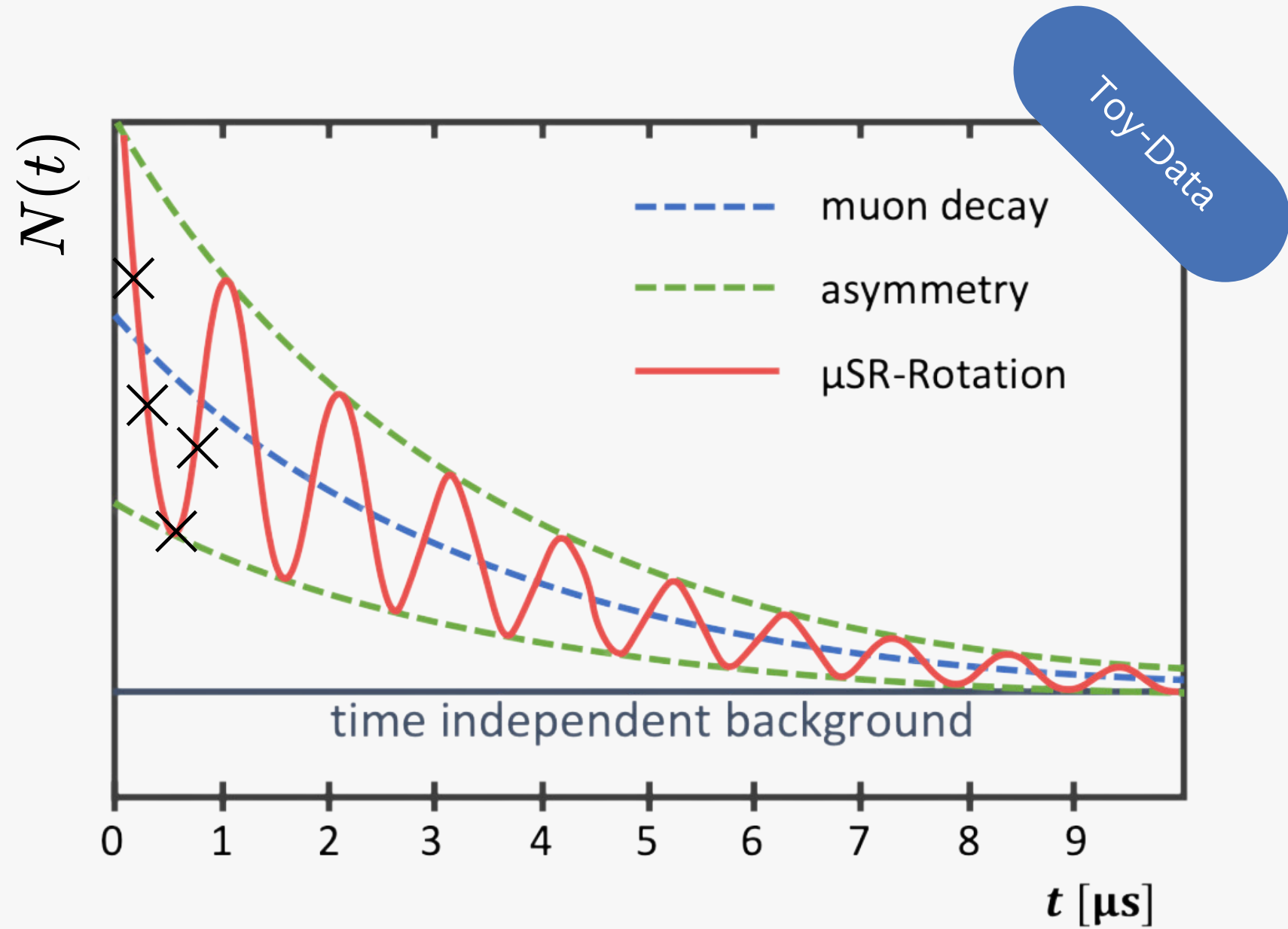

## Positron detector

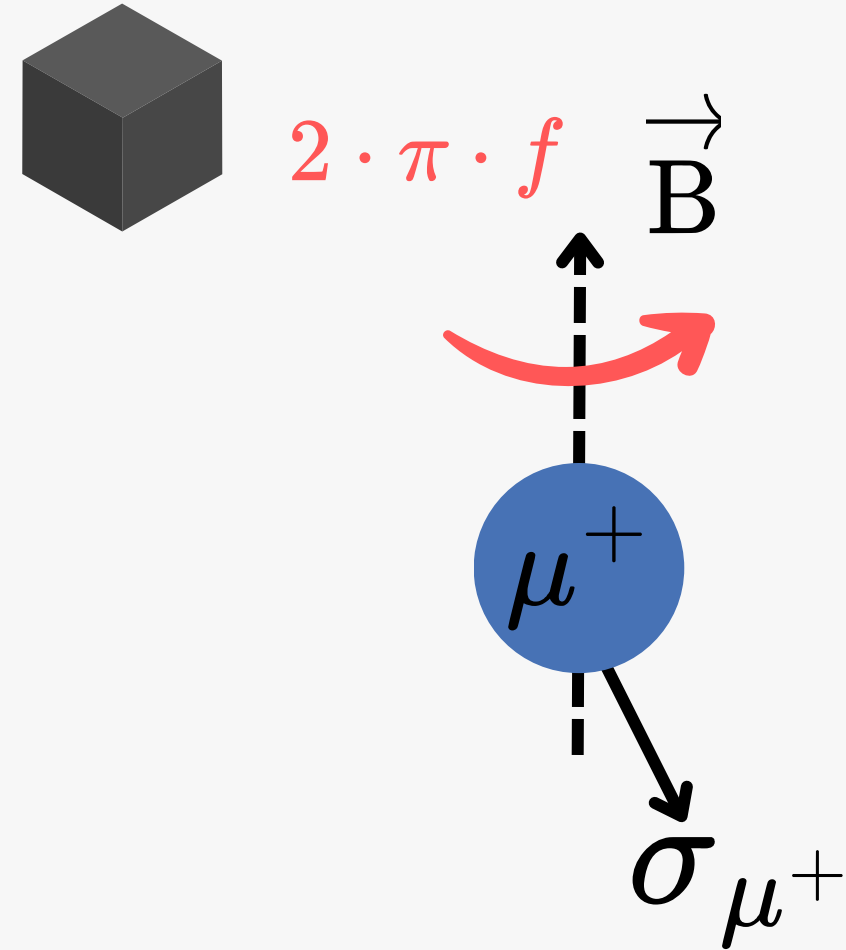

# μSR Principle

$$N(t) = N_{bkg} + N_0 \cdot e^{-\frac{t}{\tau_\mu}} \cdot (1 + A_{sym} \cdot e^{-t \cdot lam} \cdot \cos(2 \cdot \pi \cdot f \cdot t + \varphi))$$

$N_{bkg}$ : Background  
 $N_0 \cdot e^{-\frac{t}{\tau_\mu}}$ : Exponential muon decay  
 $A_{sym}$ : Intrinsic asymmetry parameter of weak decay  
 $e^{-t \cdot lam}$ : Relaxation function of temporal decrease of the polarization degree  
 $\cos(2 \cdot \pi \cdot f \cdot t + \varphi)$ : Angle between positron and muon spin direction (Larmor frequency of muon spin precession)

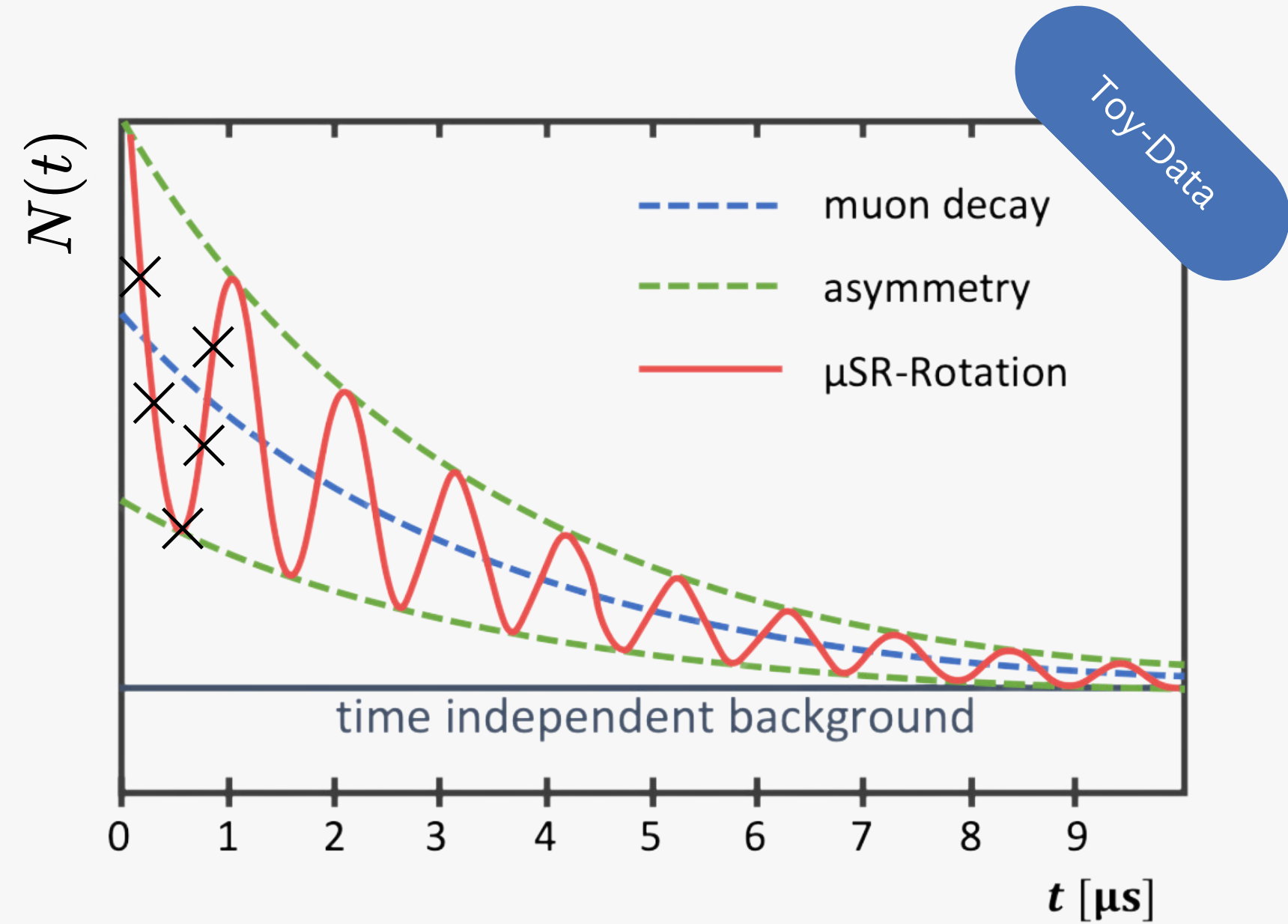

## Positron detector

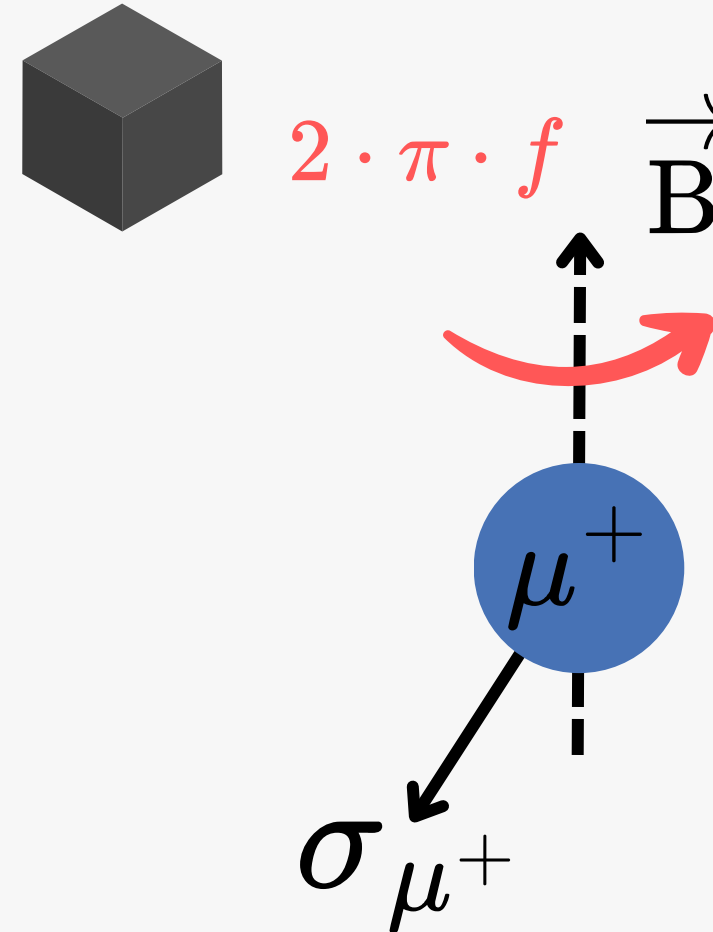

# μSR Principle

$$N(t) = N_{bkg} + N_0 \cdot e^{-\frac{t}{\tau_\mu}} \cdot (1 + A_{sym} \cdot e^{-t \cdot lam} \cdot \cos(2 \cdot \pi \cdot f \cdot t + \varphi))$$

$N_{bkg}$ : Background  
 $N_0 \cdot e^{-\frac{t}{\tau_\mu}}$ : Exponential muon decay  
 $A_{sym}$ : Intrinsic asymmetry parameter of weak decay  
 $e^{-t \cdot lam}$ : Relaxation function of temporal decrease of the polarization degree  
 $\cos(2 \cdot \pi \cdot f \cdot t + \varphi)$ : Angle between positron and muon spin direction (Larmor frequency of muon spin precession)

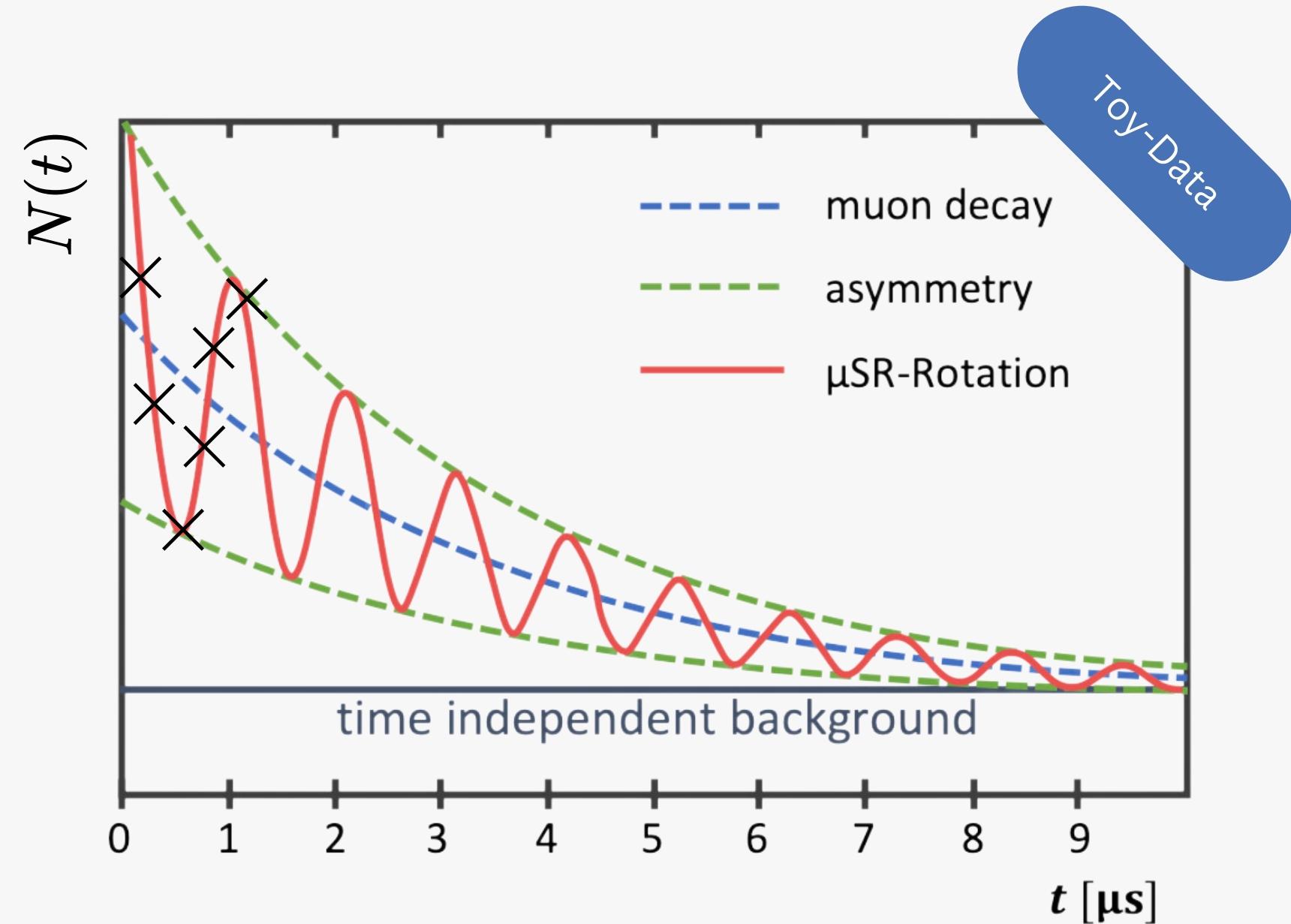

## Positron detector

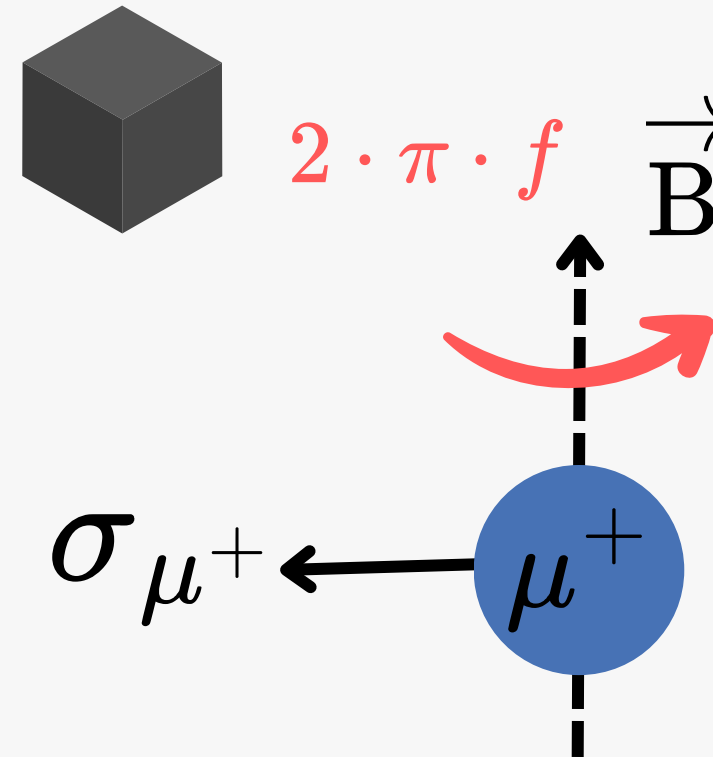

# μSR Principle

$$N(t) = N_{bkg} + N_0 \cdot e^{-\frac{t}{\tau_\mu}} \cdot (1 + A_{sym} \cdot e^{-t \cdot lam} \cdot \cos(2 \cdot \pi \cdot f \cdot t + \varphi))$$

$N_{bkg}$ : Background  
 $N_0 \cdot e^{-\frac{t}{\tau_\mu}}$ : Exponential muon decay  
 $A_{sym}$ : Intrinsic asymmetry parameter of weak decay  
 $e^{-t \cdot lam}$ : Relaxation function of temporal decrease of the polarization degree  
 $\cos(2 \cdot \pi \cdot f \cdot t + \varphi)$ : Angle between positron and muon spin direction (Larmor frequency of muon spin precession)

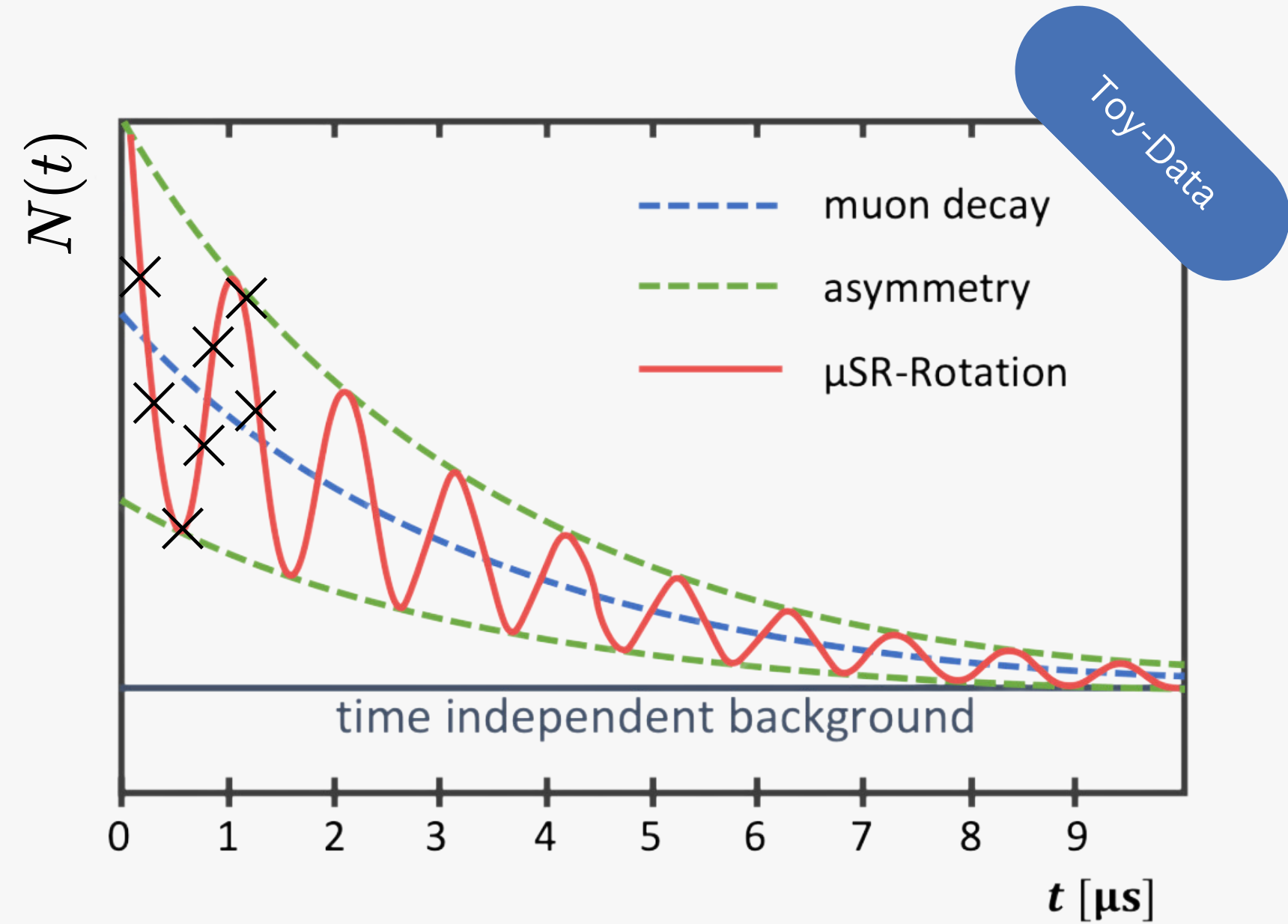

## Positron detector

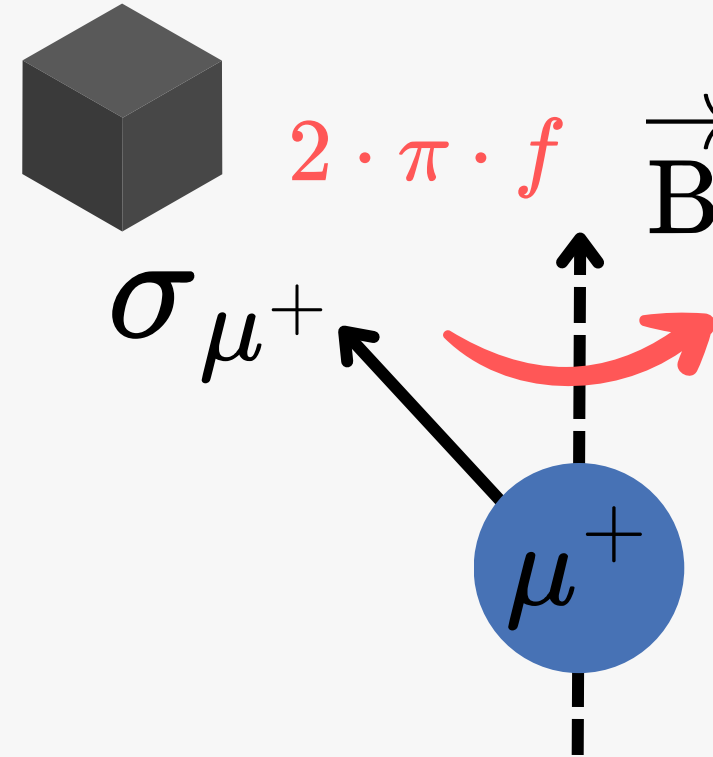

# $\mu$ SR Principle

$$N(t) = N_{bkg} + N_0 \cdot e^{-\frac{t}{\tau_\mu}} \cdot (1 + A_{sym} \cdot e^{-t \cdot lam} \cdot \cos(2 \cdot \pi \cdot f \cdot t + \varphi))$$

$N_{bkg}$ : Background  
 $N_0 \cdot e^{-\frac{t}{\tau_\mu}}$ : Exponential muon decay  
 $A_{sym}$ : Intrinsic asymmetry parameter of weak decay  
 $e^{-t \cdot lam}$ : Relaxation function of temporal decrease of the polarization degree  
 $\cos(2 \cdot \pi \cdot f \cdot t + \varphi)$ : Angle between positron and muon spin direction (Larmor frequency of muon spin precession)

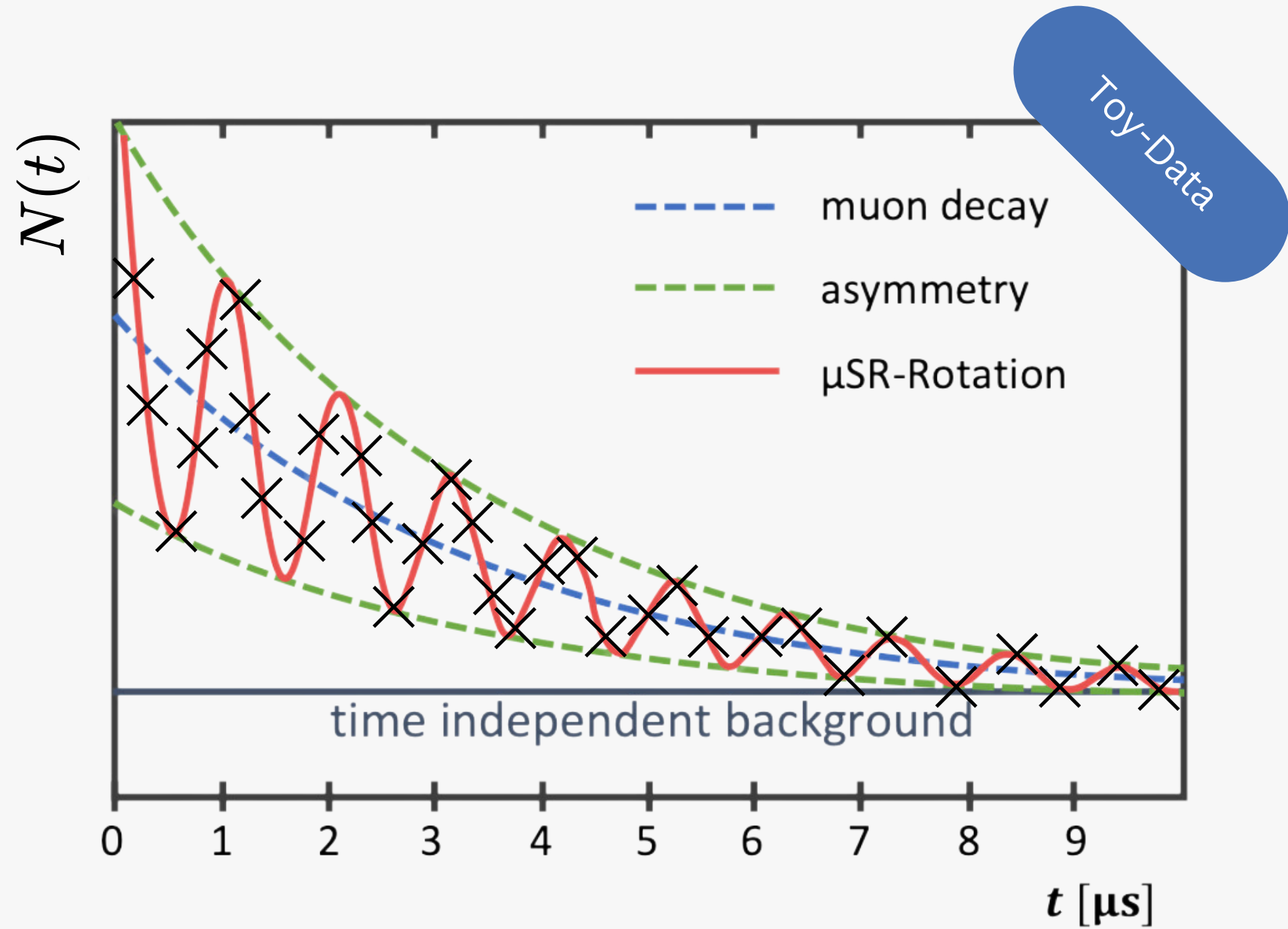

## Positron detector

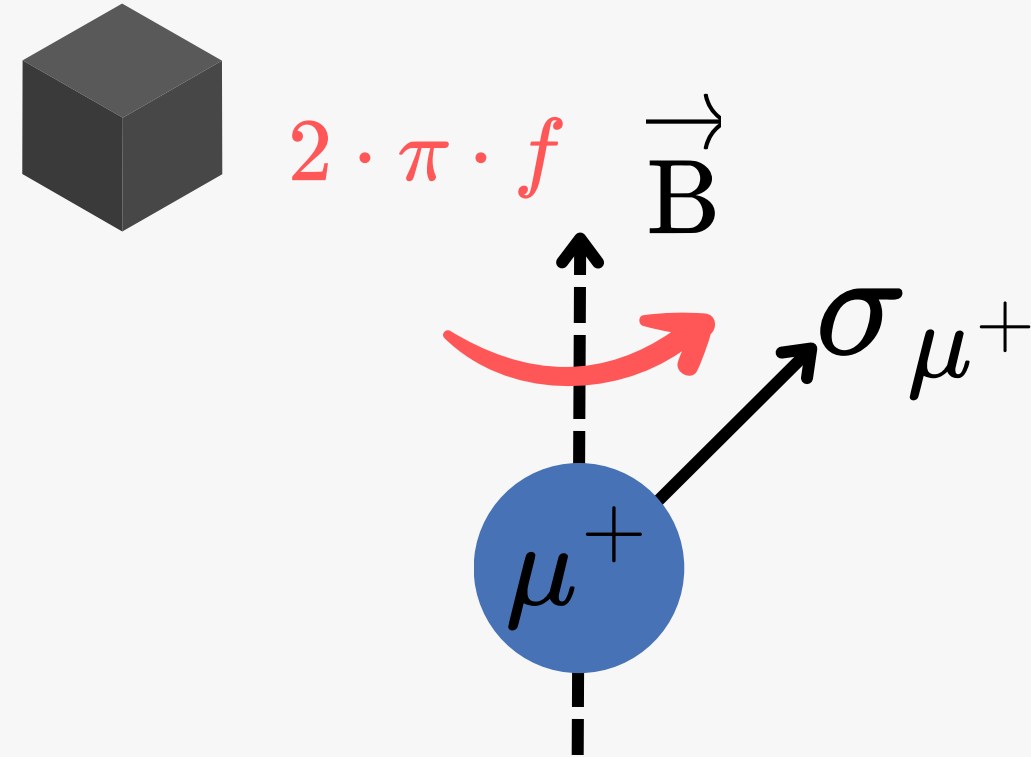

# Scintillator-based Detector (Current Generation)

## Measure:

- Time of Arrival of muon and positron
- Temporal asymmetry between forward and backward signals

## Limitations:

- No positional information of muon
- Rate limitation
  - Maximal 1 muon per time frame
  - Limited observation time
    - 40 kHz (18 kHz acceptance)

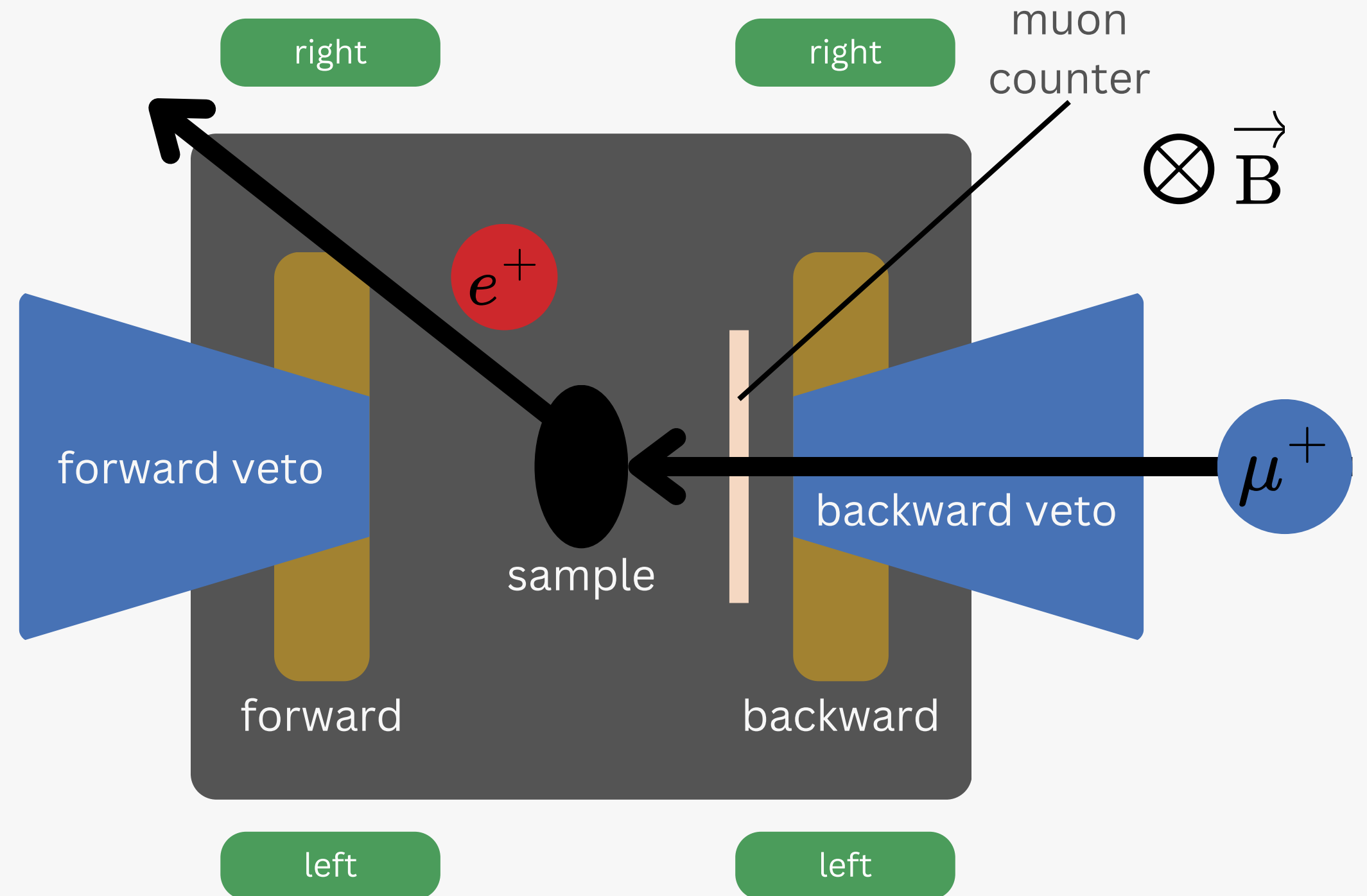

Adapted from: General Purpose Surface-Muon Instrument (GPS). User Guide.

# Scintillator-based Detector (Current Generation)

## Measure:

- Time of Arrival of muon and positron
- Temporal asymmetry between forward and backward signals

## Limitations:

- No positional information of muon
- Rate limitation
  - Maximal 1 muon per time frame
  - Limited observation time
    - 40 kHz (18 kHz acceptance)

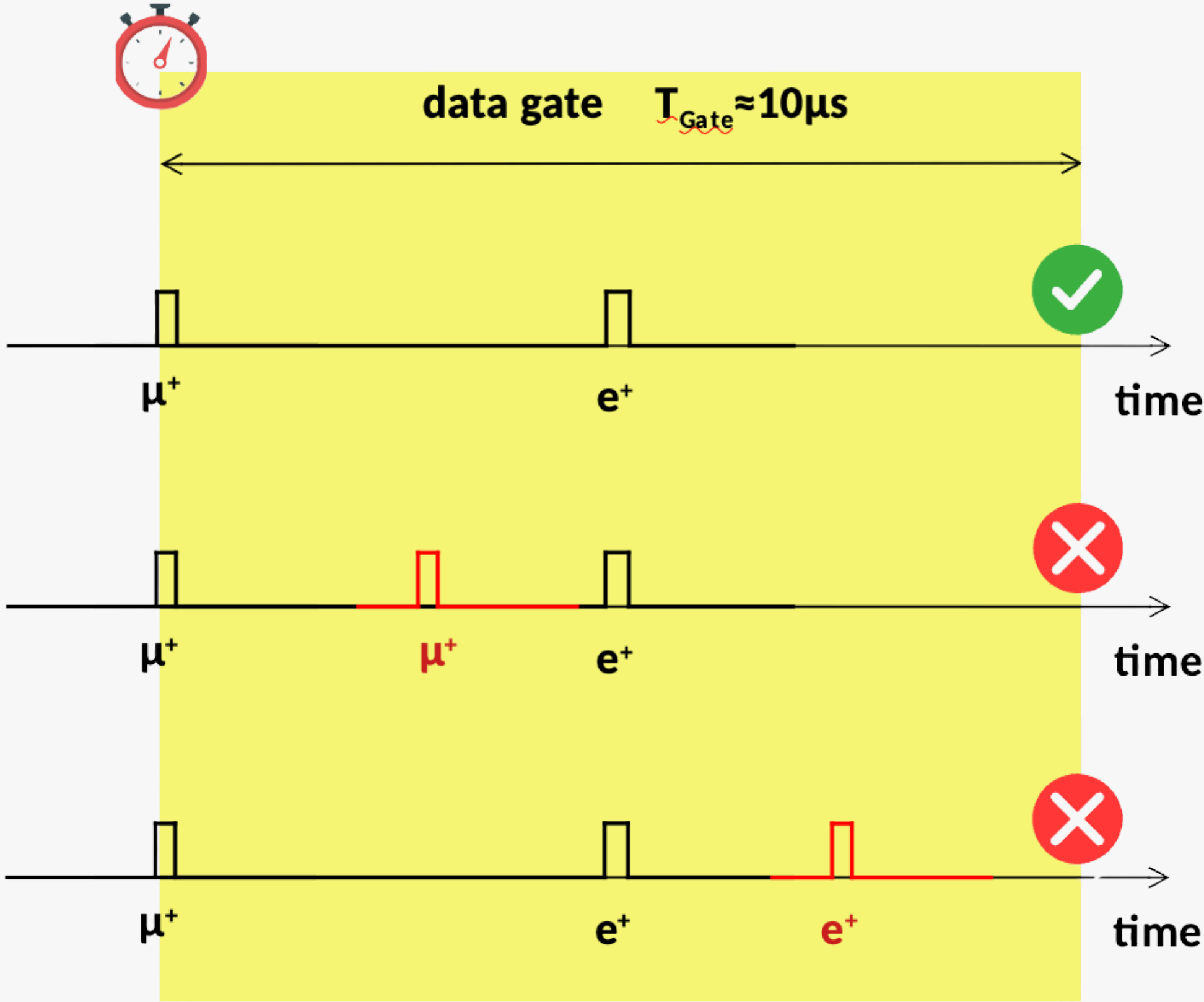

# Scintillator-based Detector (Current Generation)

## Measure:

- Time of Arrival of muon and positron
- Temporal asymmetry between forward and backward signals

## Limitations:

- No positional information of muon
- Rate limitation
  - Maximal 1 muon per time frame
  - Limited observation time
    - 40 kHz (18 kHz acceptance)

Accepted rate ( $R_{acc}$ )  
versus  
incoming rate ( $R_{\mu}$ )

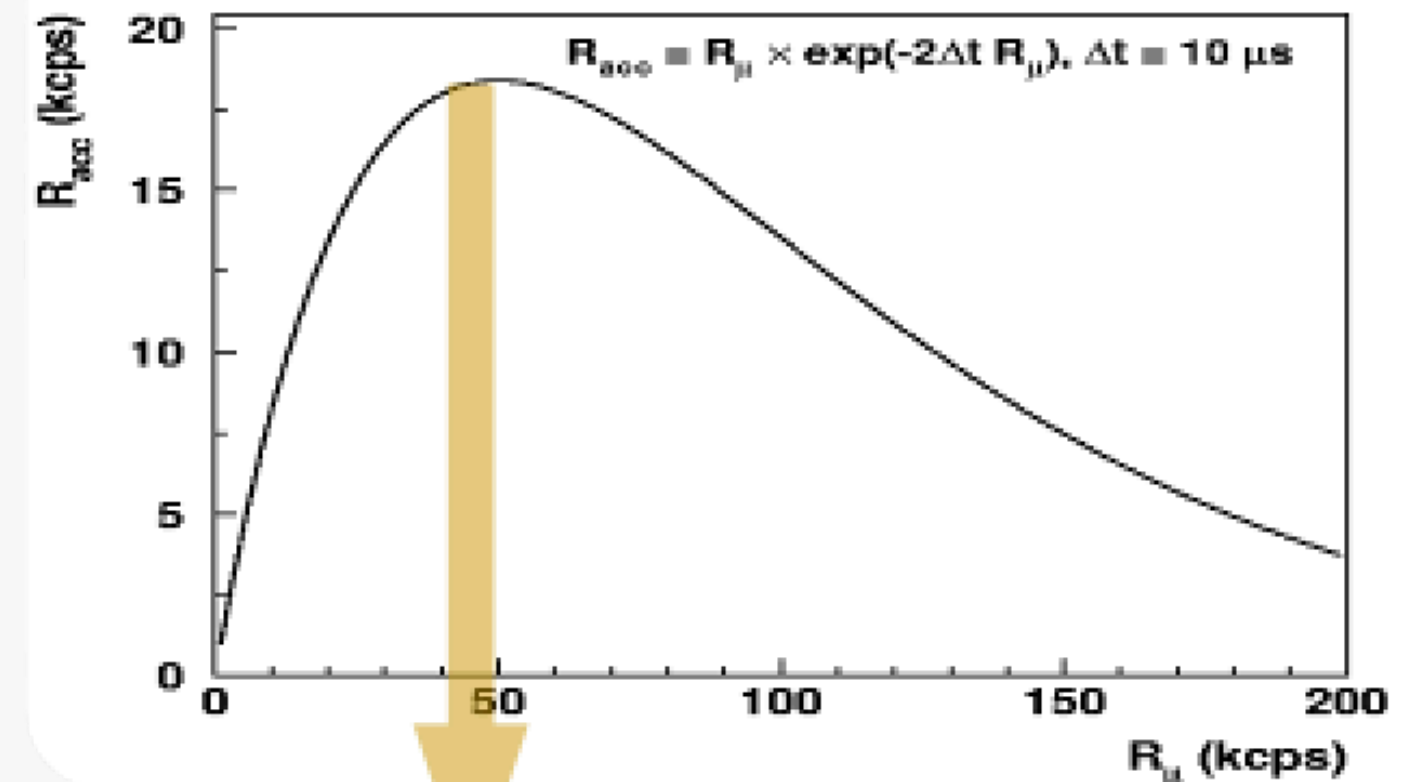

Current rate limit for  $T_{Gate} = 10 \mu s$  is  $\sim 40k$   
 $\mu^+/s$

# HIPA facility

HIMB: Muon flux \* 100  
à  $10^{10}$  surface muons/s  
Confirmed in realistic simulations!

Particle Physics (mu3e)

Material Science (vx- $\mu$ SR)

590-MeV Ring  
cyclotron

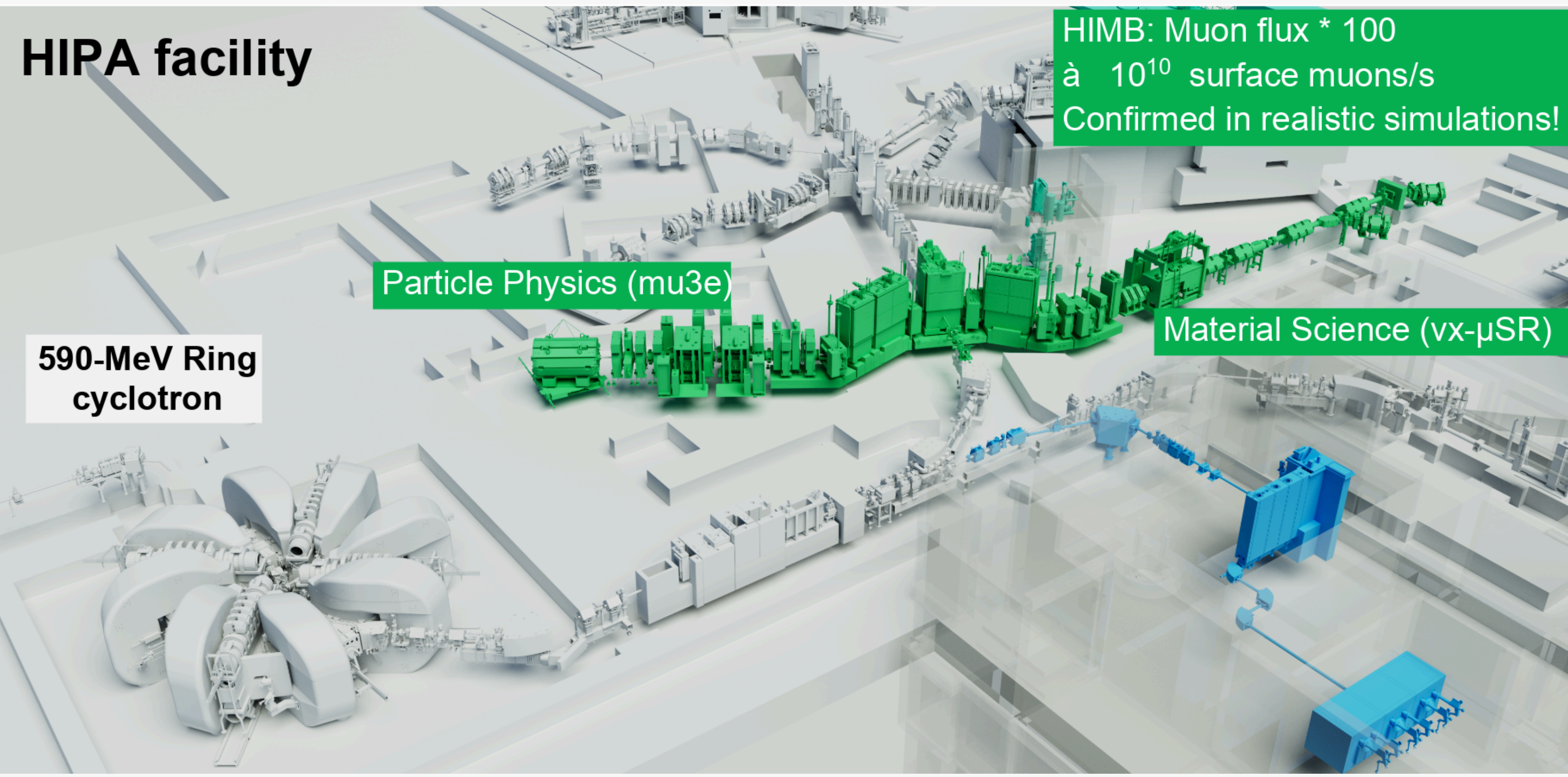

# Scintillator-based Detector (Current Generation)

## Measure:

- Time of Arrival of muon and positron
- Temporal asymmetry between forward and backward signals

## Limitations:

- No positional information of muon
- Rate limitation
  - Maximal 1 muon per time frame
  - Limited observation time
    - 40 kHz (18 kHz acceptance)

## Current Setup:

- Keep current version of GPS
- Have a new one to move in at any time
- 50% of all MuSR publications at PSI using GPS at one point

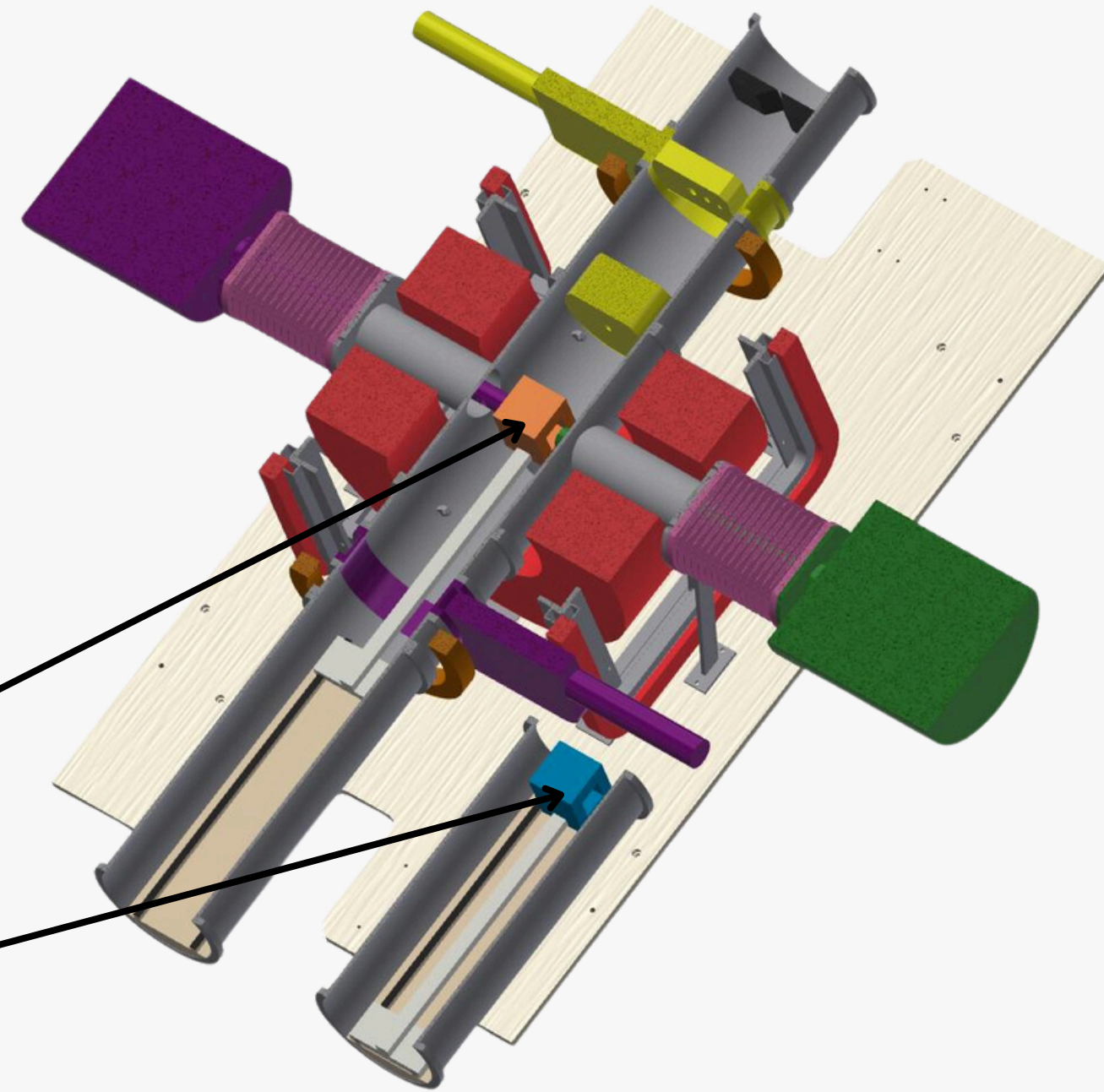

# Next Generation

MULTI—new detector, new logic, new science

K.H. Chow<sup>a,\*</sup>, R.F. Kiefl<sup>b,c</sup>, S. Chan<sup>c</sup>, R.I. Miller<sup>b,c</sup>, P. Amadruz<sup>c</sup>, R. Poutissou<sup>c</sup>,  
B. Hitti<sup>c</sup>, D. Arseneau<sup>c</sup>

**First segmented detector from 2003**

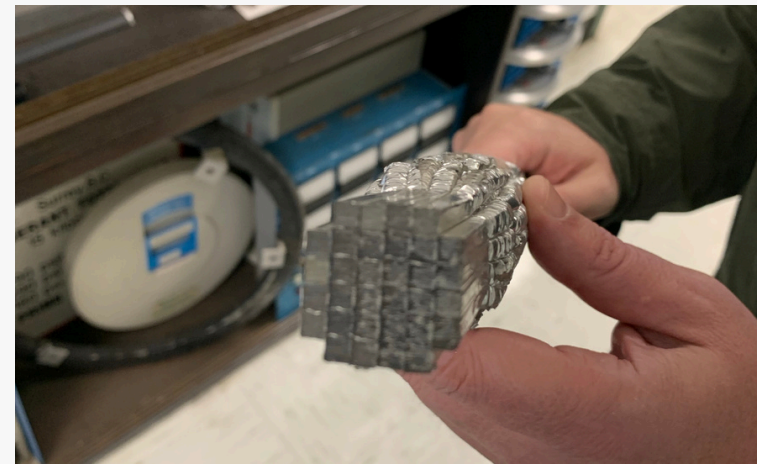

Position-sensitive detectors for muon spectroscopy:  
Design goals, constraints and perspectives







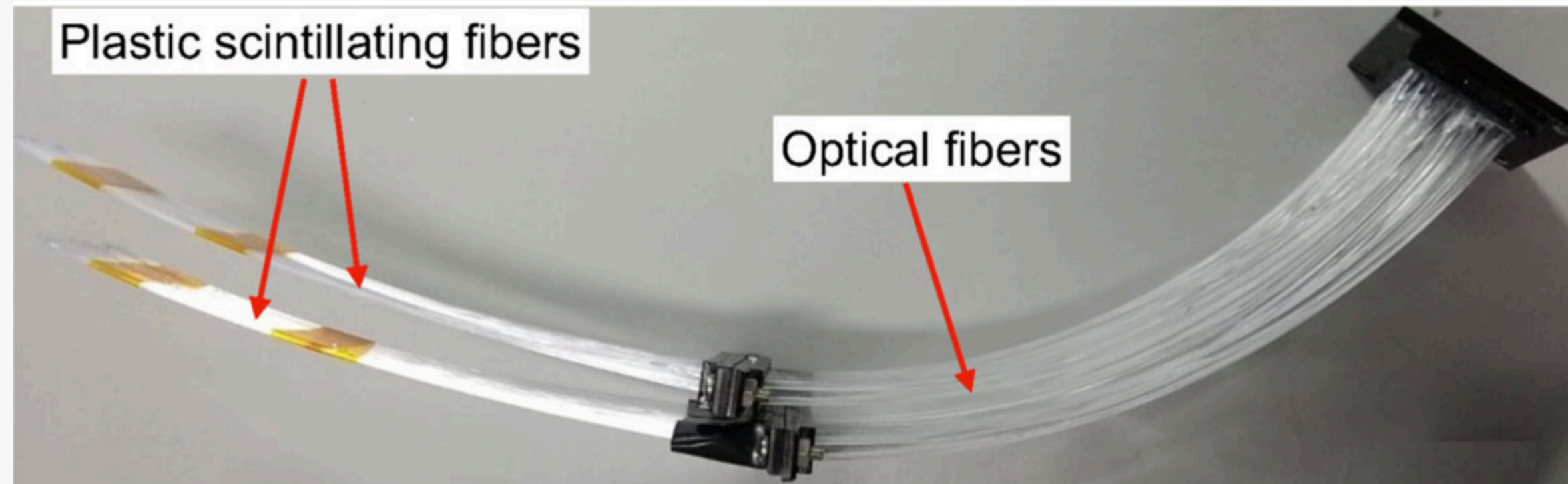



T. Shiroka<sup>a,\*</sup>, R. De. Renzi<sup>a</sup>, C. Bucci<sup>a</sup>, R. Scheuermann<sup>b</sup>, E. Morenzoni<sup>b</sup>

**Idea of using Si-Pixel around since 2006**

# Next Generation



## Development of muon spin imaging spectroscopy

Takato Sugisaki<sup>1,2,8,9</sup>  · Kenji M. Kojima<sup>2,8</sup>  · Mototsugu Mihara<sup>1,8</sup>  ·  
Yoko Kimura<sup>1,8</sup> · Yutaka Mizoi<sup>3,8</sup>  · Gen Takayama<sup>1</sup>  · Daiki Nishimura<sup>4</sup> ·  
Masaomi Tanaka<sup>5,8</sup>  · Soshi Ishitani<sup>1</sup>  · Gerald Morris<sup>2</sup>  · Donald Arseneau<sup>2</sup> ·  
Rahim Abasalti<sup>2</sup> · Deepak Vyas<sup>2</sup> · Mitsunori Fukuda<sup>1</sup> · Wataru Sato<sup>6</sup> ·  
Runa Yasuda<sup>7</sup>  · Ryo Taguchi<sup>1</sup> 

Accepted: 22 February 2024

# TABLE OF CONTENTS

01 | MuSR at PSI

02 | HV-MAPS & DAQ

03 | Results

# High Voltage Monolithic Active Pixel Sensors (HV-MAPS)

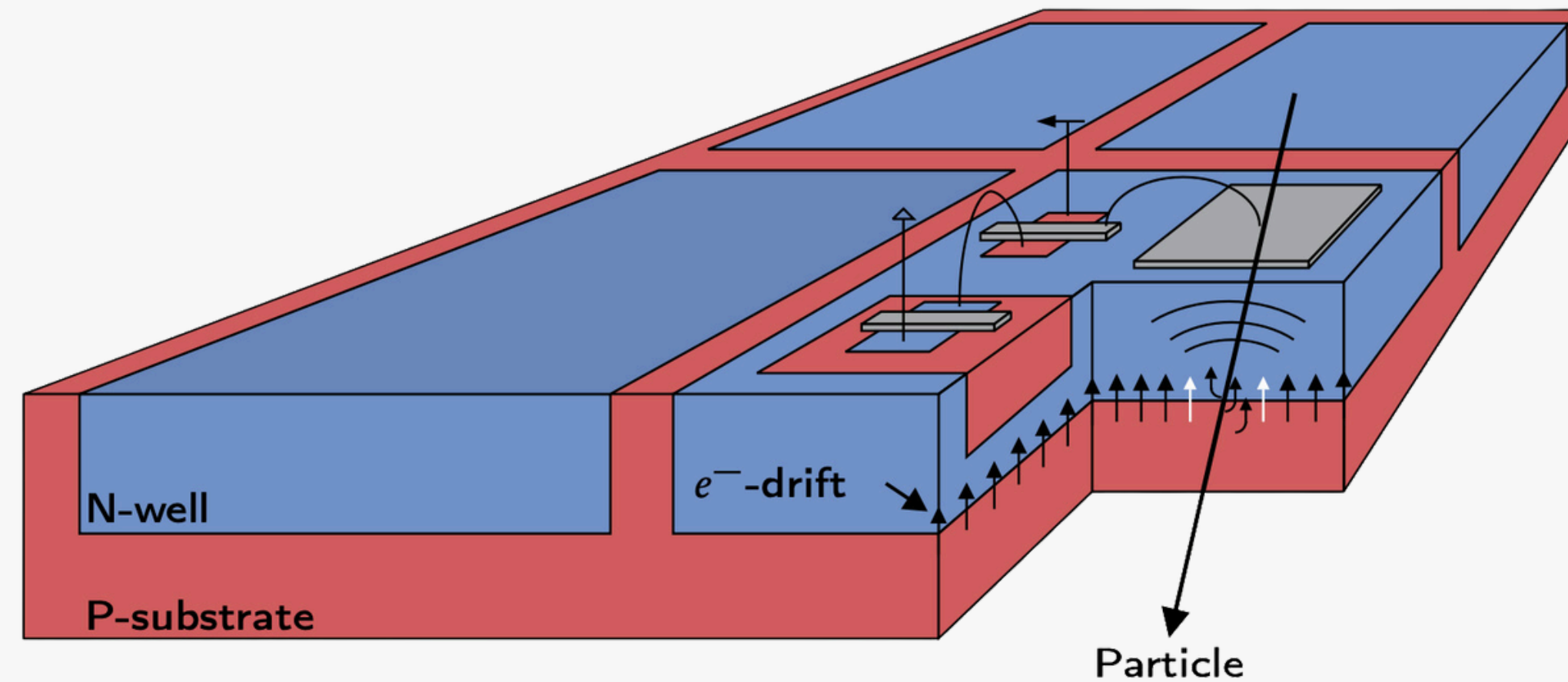

Ivan Perić et al., NIM A582 (2007) 876-885

- High Voltage Monolithic Active Pixel Sensors
- **Thinned** down to **50 μm**
- Fast charge collection via **drift**
- **Time resolution** of a few **ns**
- **Digitalization** and **zero suppression** on the chip

# High Voltage Monolithic Active Pixel Sensors (HV-MAPS)

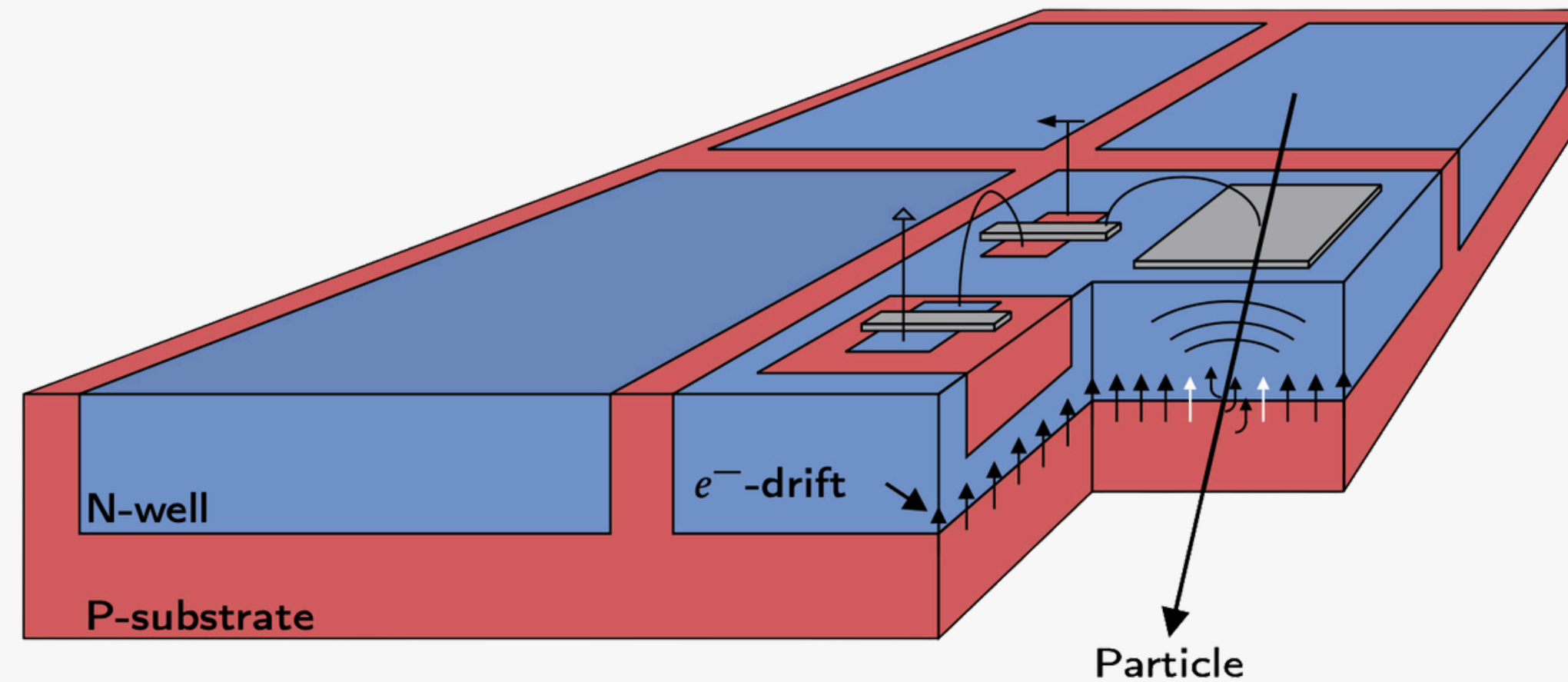

Ivan Perić et al., NIM A582 (2007) 876-885

- High Voltage Monolithic Active Pixel Sensors
- **Thinned** down to **50 μm**
- Fast charge collection via **drift**
- **Time resolution** of a few **ns**
- **Digitalization** and **zero suppression** on the chip

**good vertex resolution and momentum measurement**

# Quad Module (Next Generation)

## 2 x 2 MuPix11 Module:

- (4 x 4) qcm active area
- 50 - 100 um sensor thickness

## MuPix:

- Pixel Matrix: 256 x 250
- Pixel Size: (80 x 80)  $\mu m^2$
- Time Binning: 8 ns (125 MHz readout)
- Datalink Speed: 3 x 1.25 Gbit/s

copper layer for cooling

Designed by Lukas Mandok

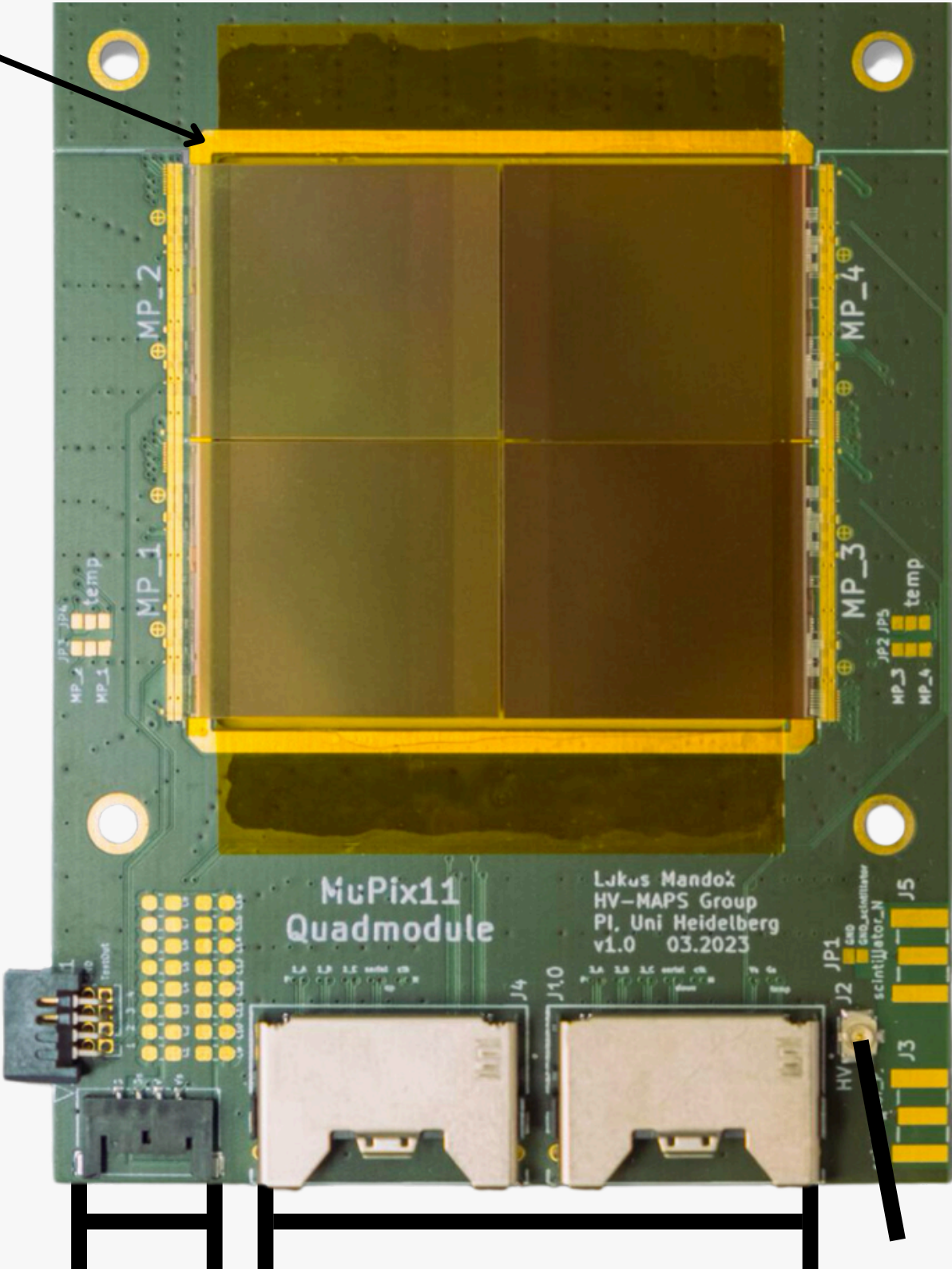

4 cm

LV Data HV

# Quad Module (Next Generation)

## 2 x 2 MuPix11 Module:

- (4 x 4) qcm active area
- 50 - 100 um sensor thickness

## MuPix:

- Pixel Matrix: 256 x 250
- Pixel Size: (80 x 80)  $\mu m^2$
- Time Binning: 8 ns (125 MHz readout)
- Datalink Speed: 3 x 1.25 Gbit/s

copper layer for cooling

Designed by Lukas Mandok

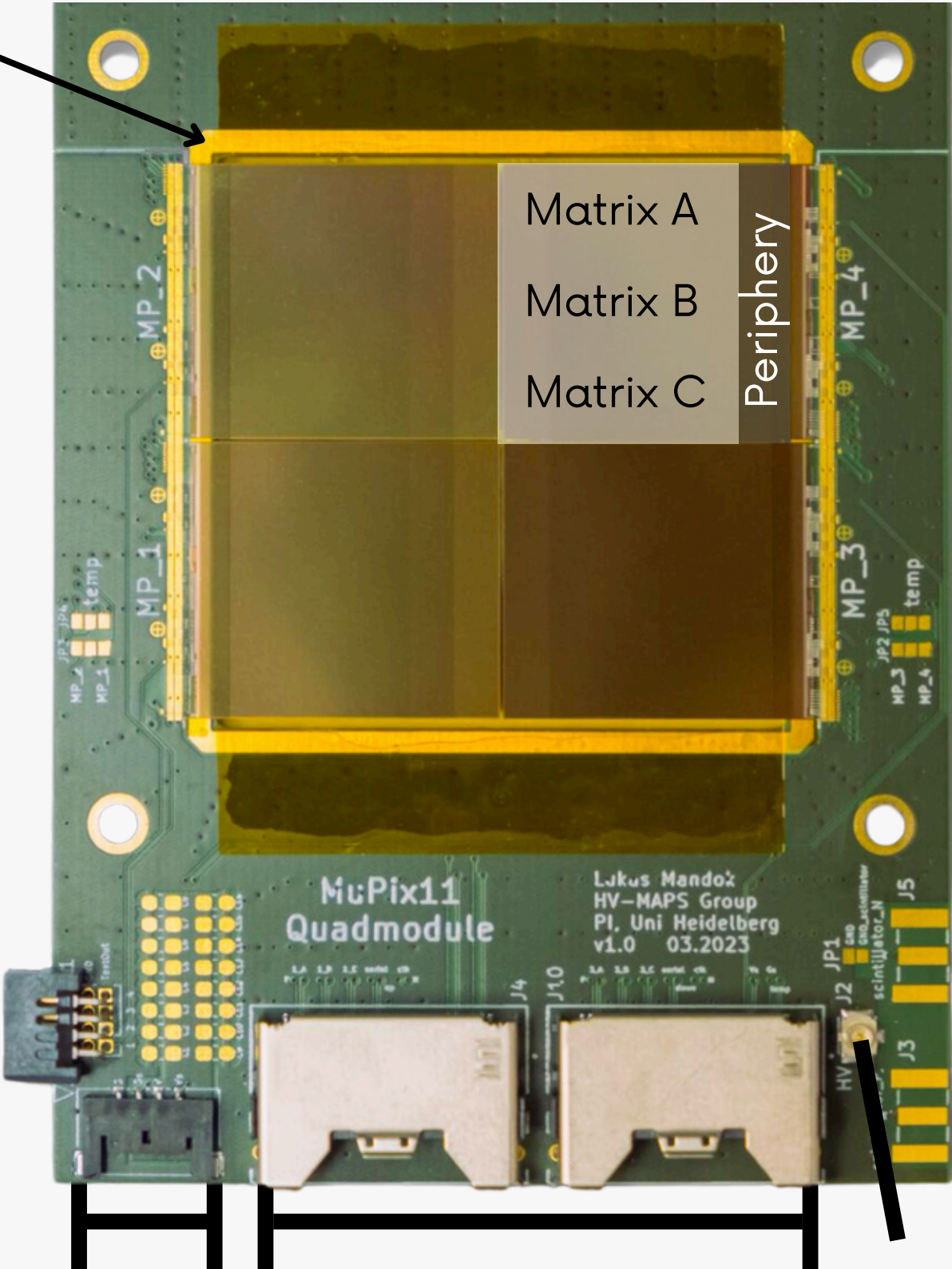

4 cm

LV

Data

HV

# Readout of MuPix

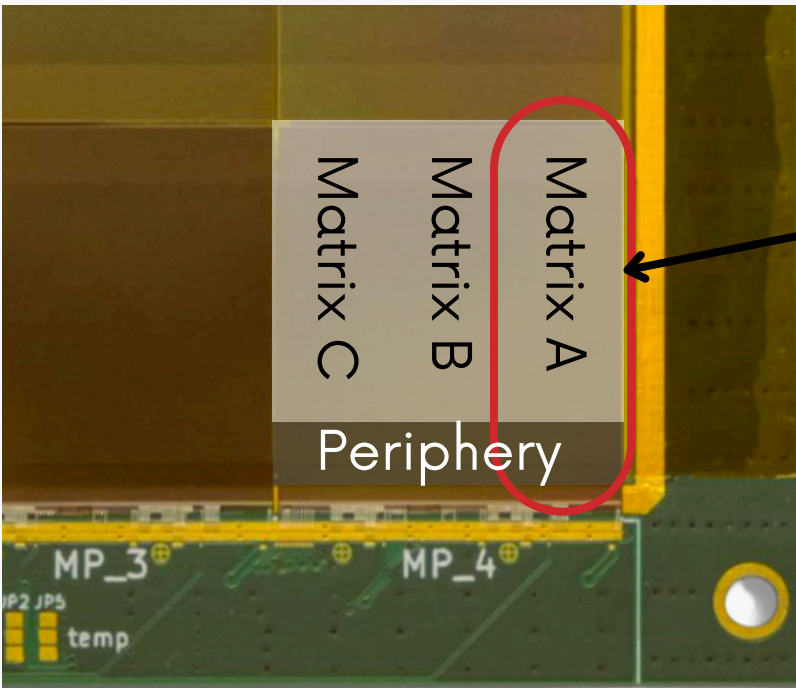

col

row

					2	
	1				3	
			2			
	3				1	
Periphery						

# Readout of MuPix

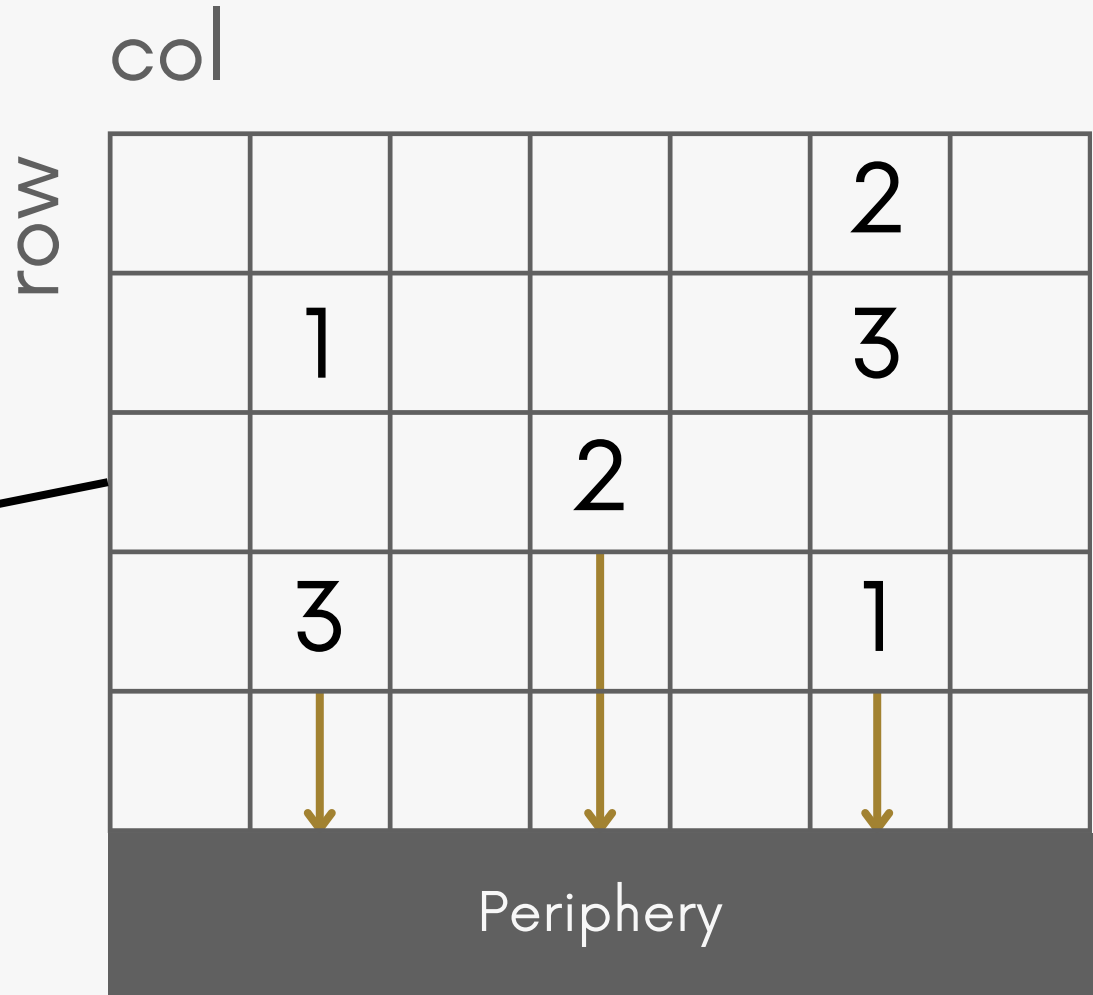
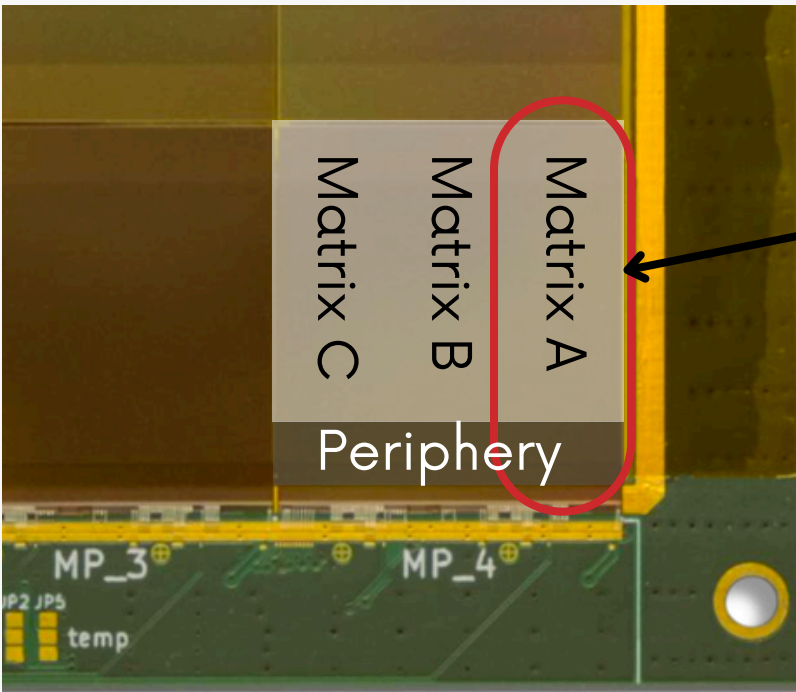

# Readout of MuPix

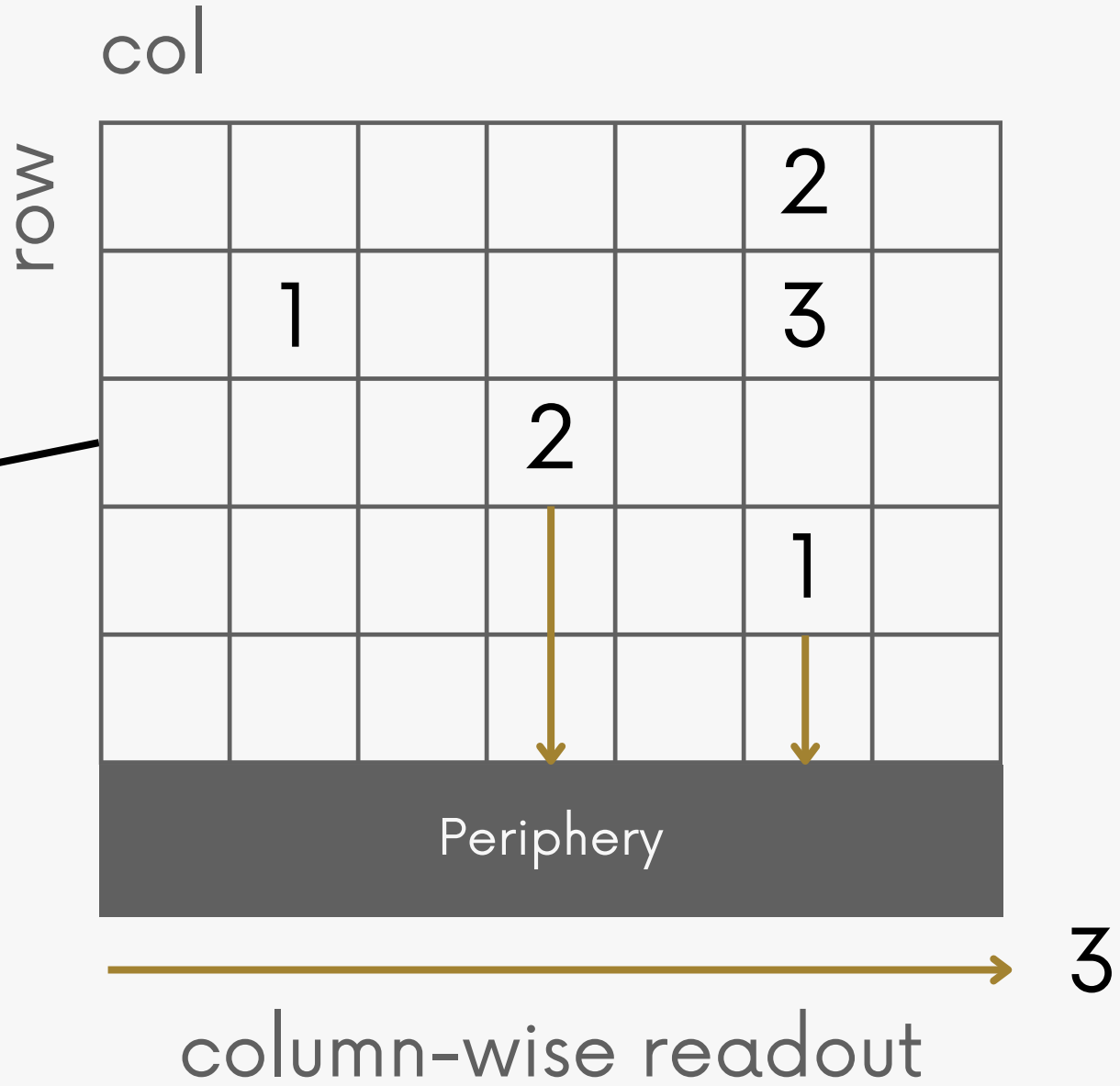
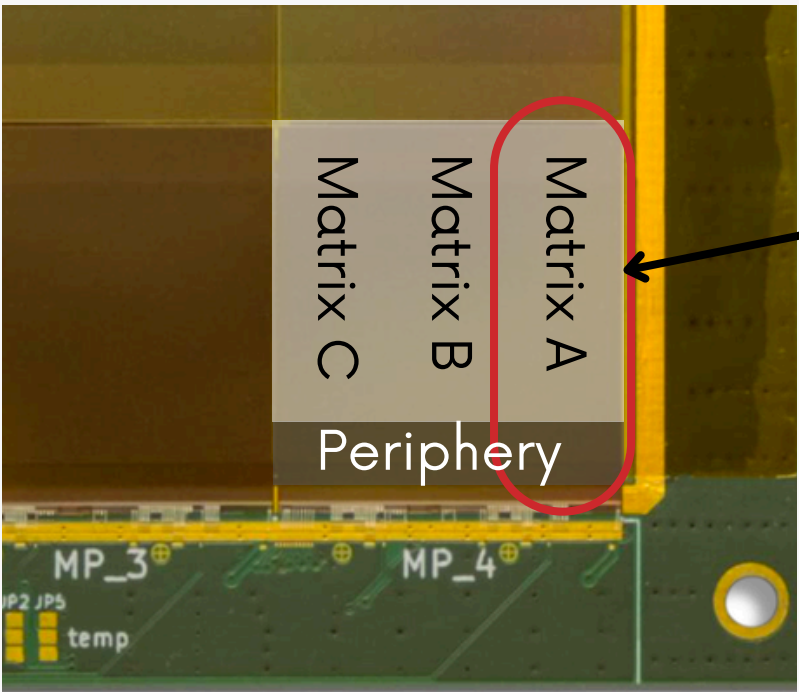

# Readout of MuPix

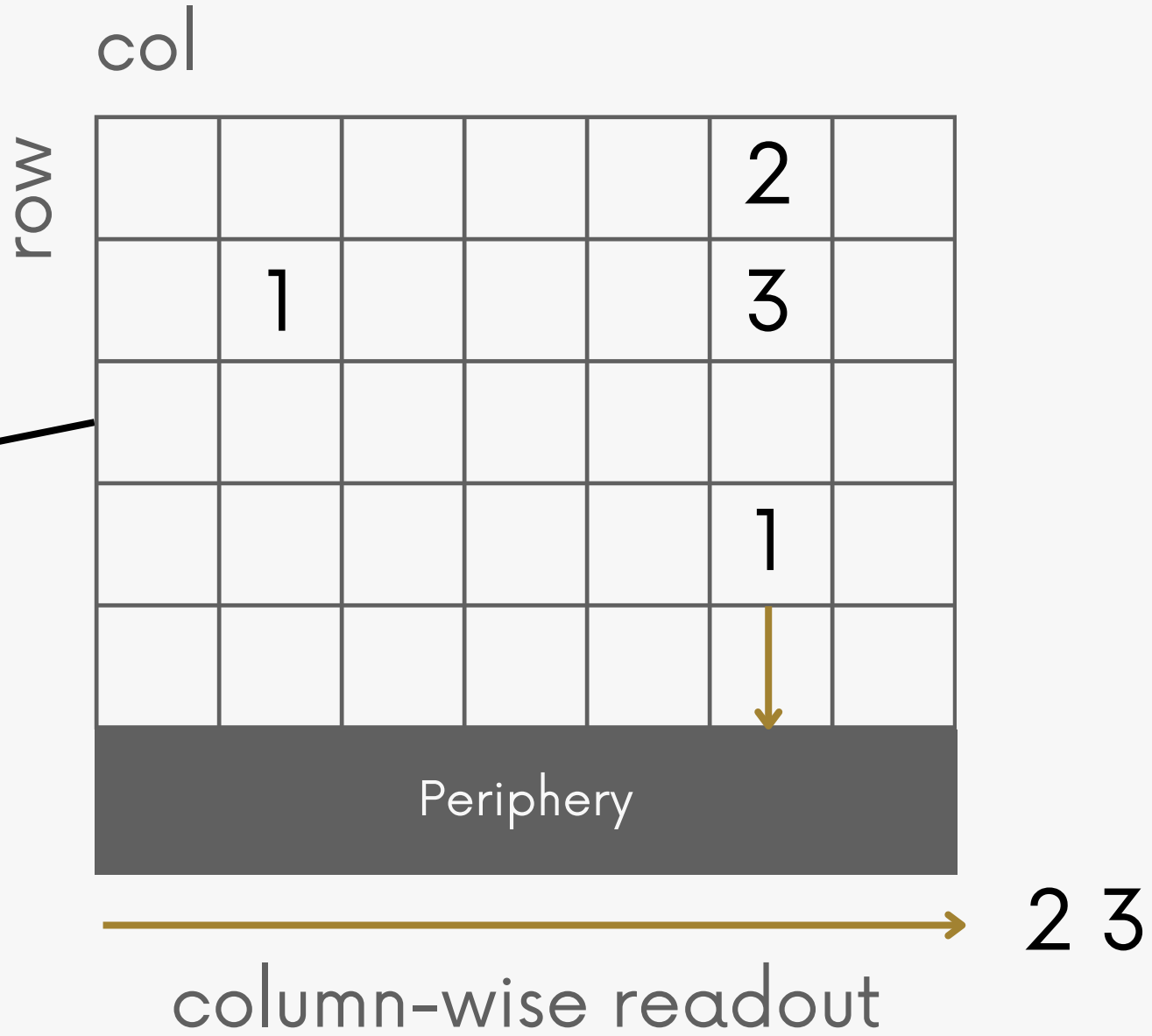
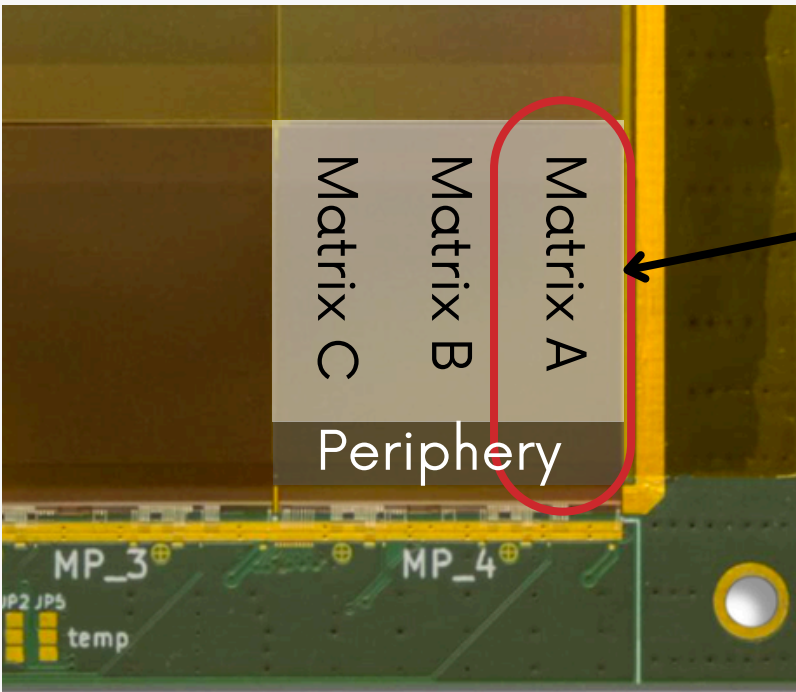

# Readout of MuPix

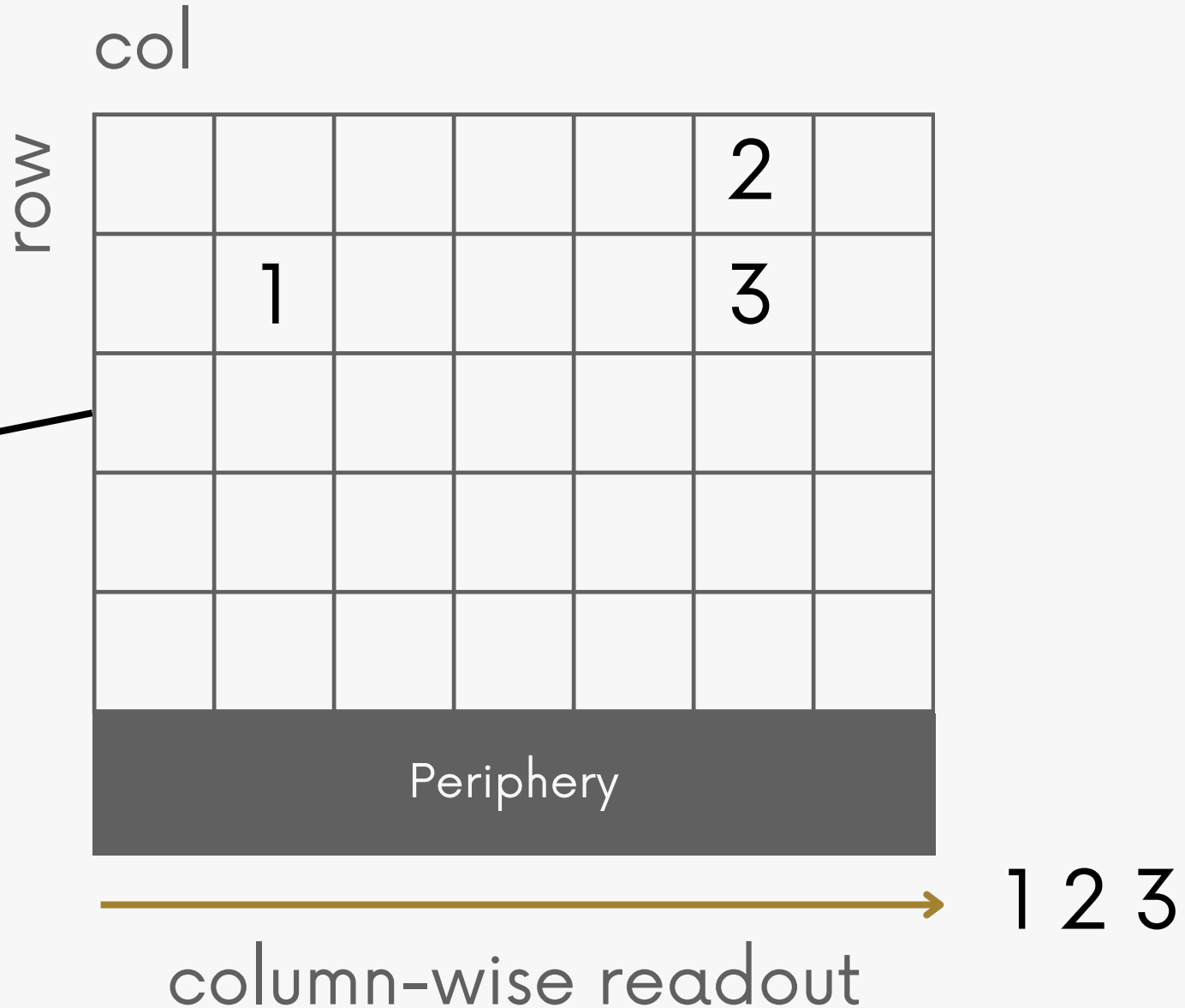
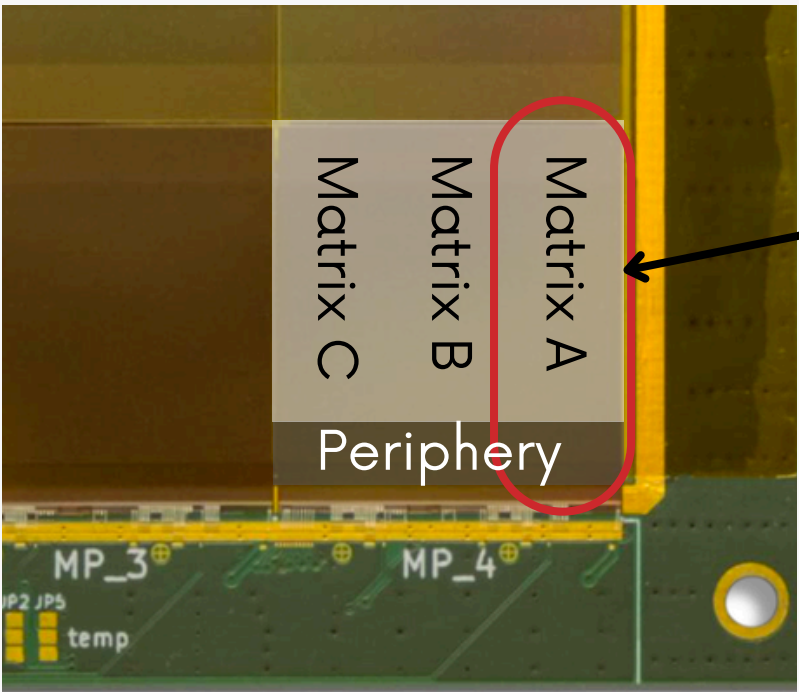

# Readout of MuPix

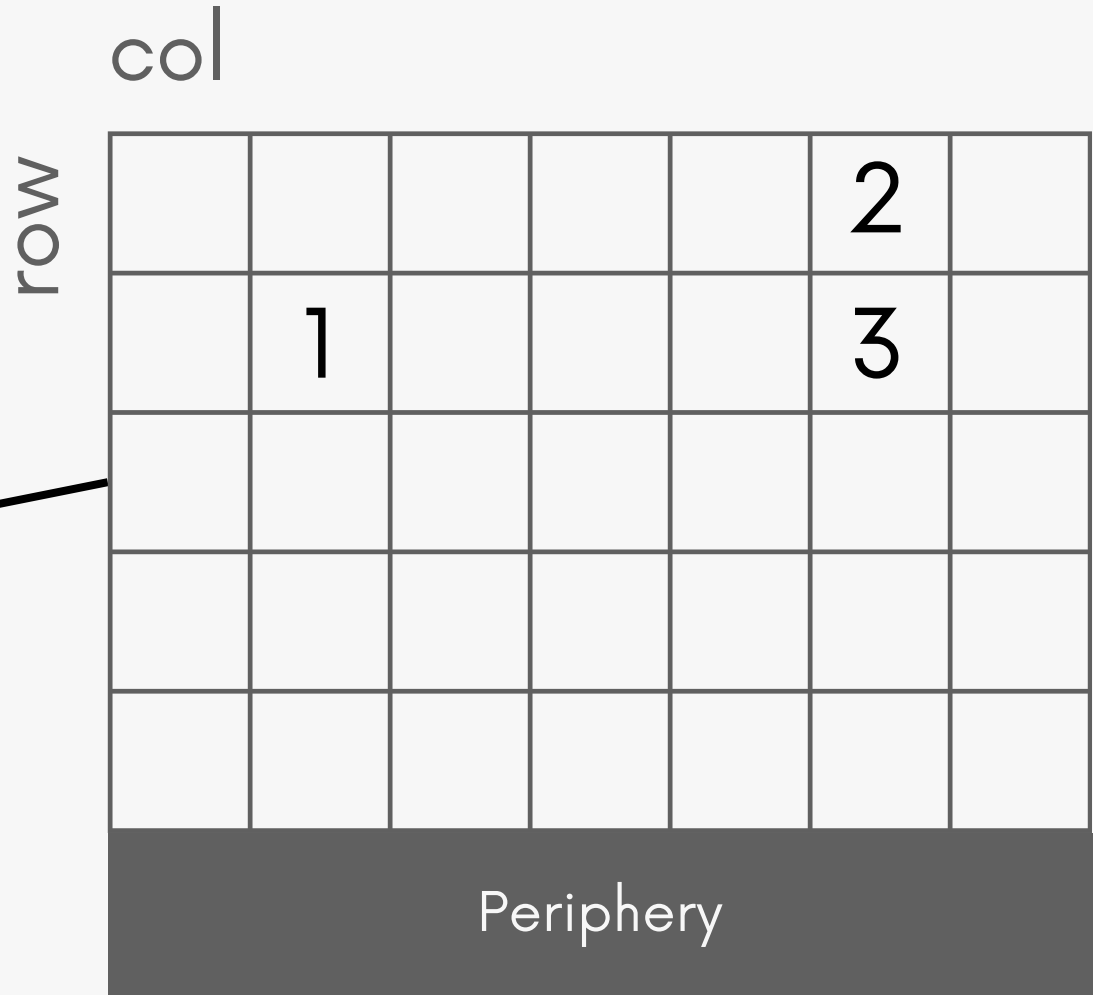
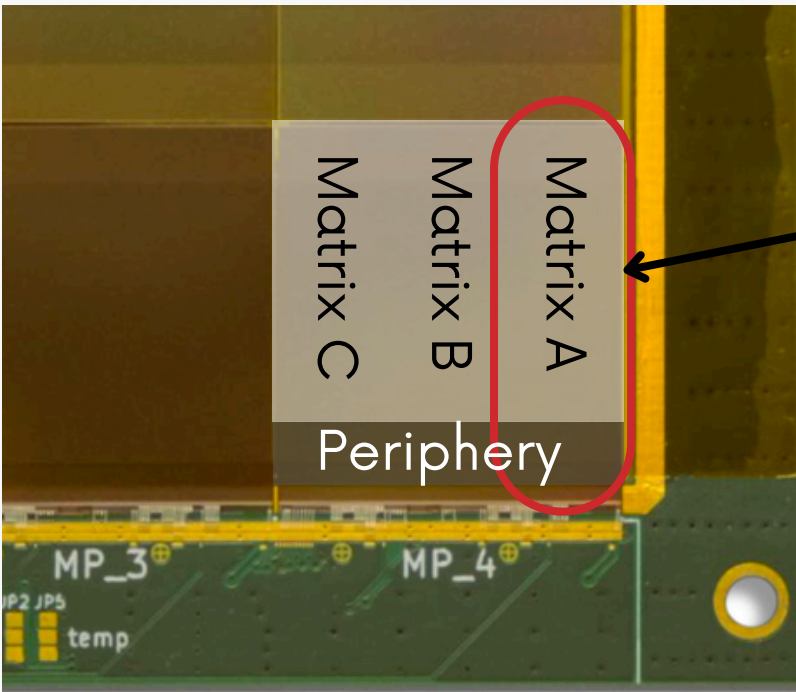

column-wise readout → 1 2 3

**DAQ challenge: up to 3 links of continuous 1.25 Gbit/s unsorted hit data**

## Front-end FPGA Board

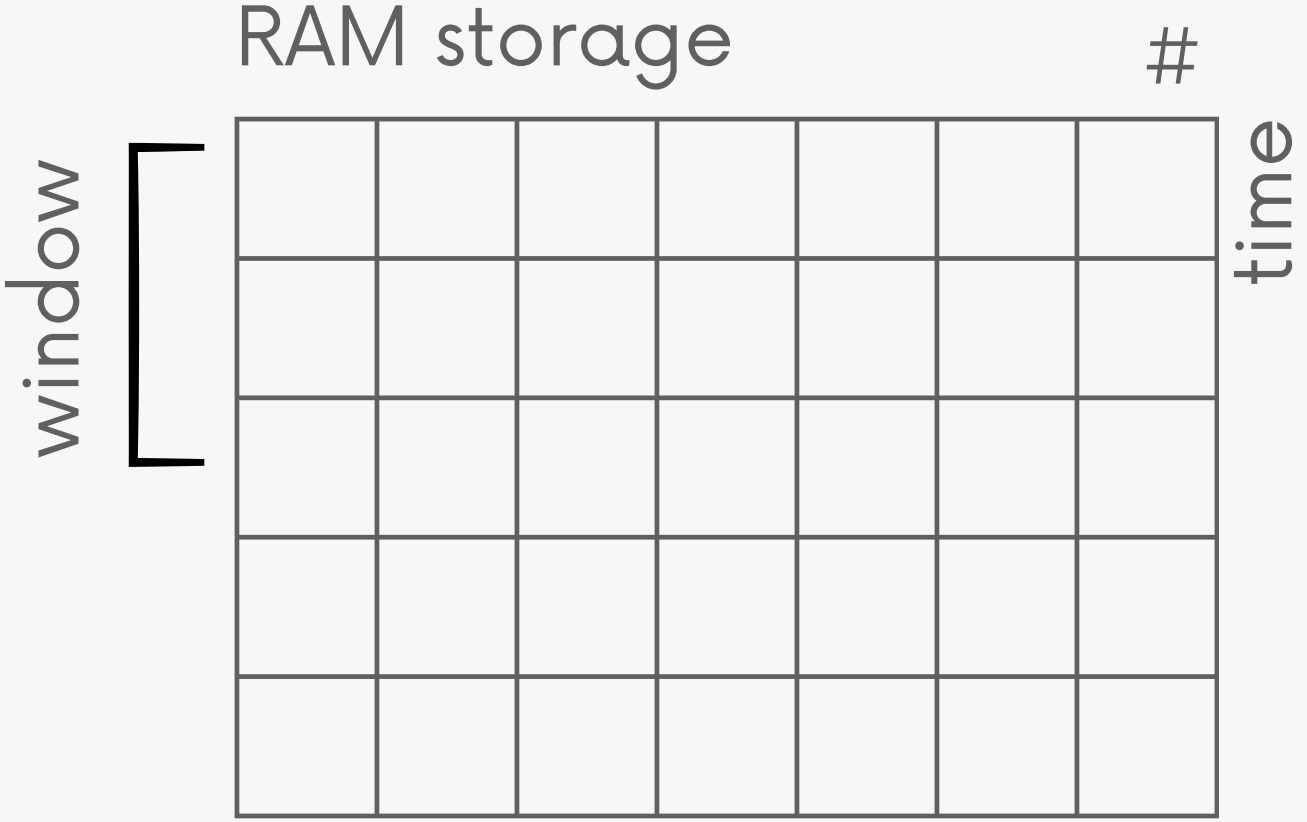

Ann-Kathrin Perrevoort PhD Thesis

# Readout of MuPix

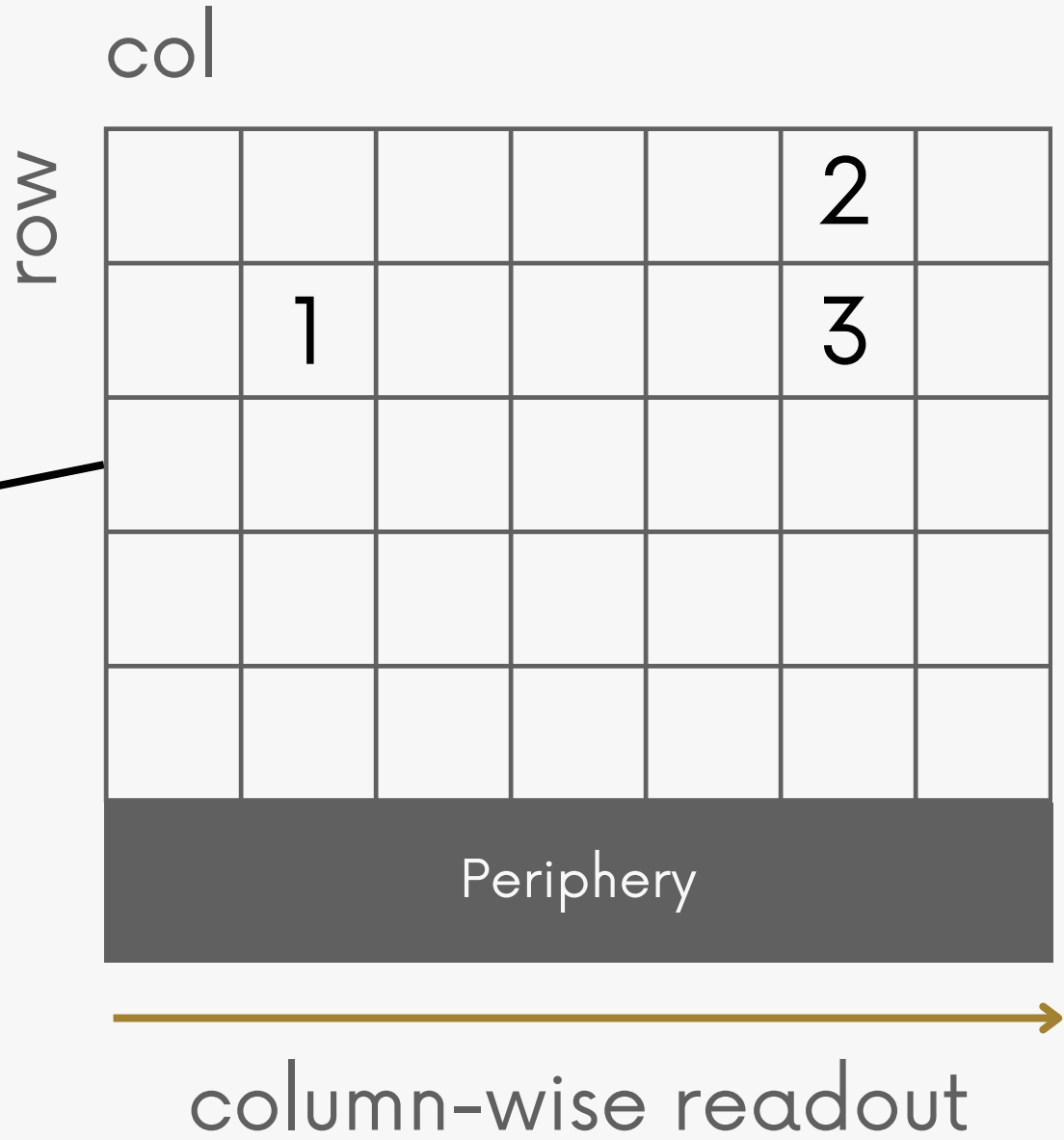
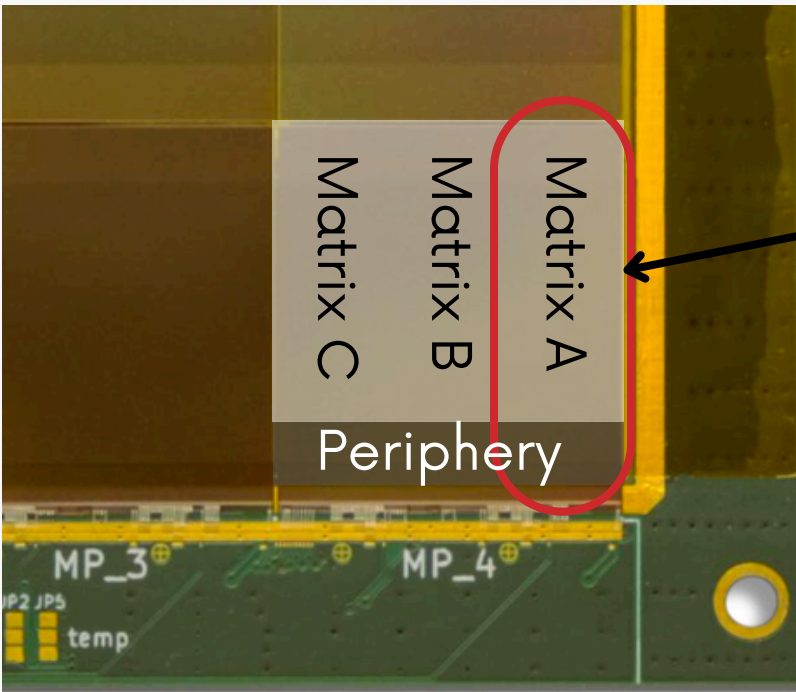

1 2

## Front-end FPGA Board

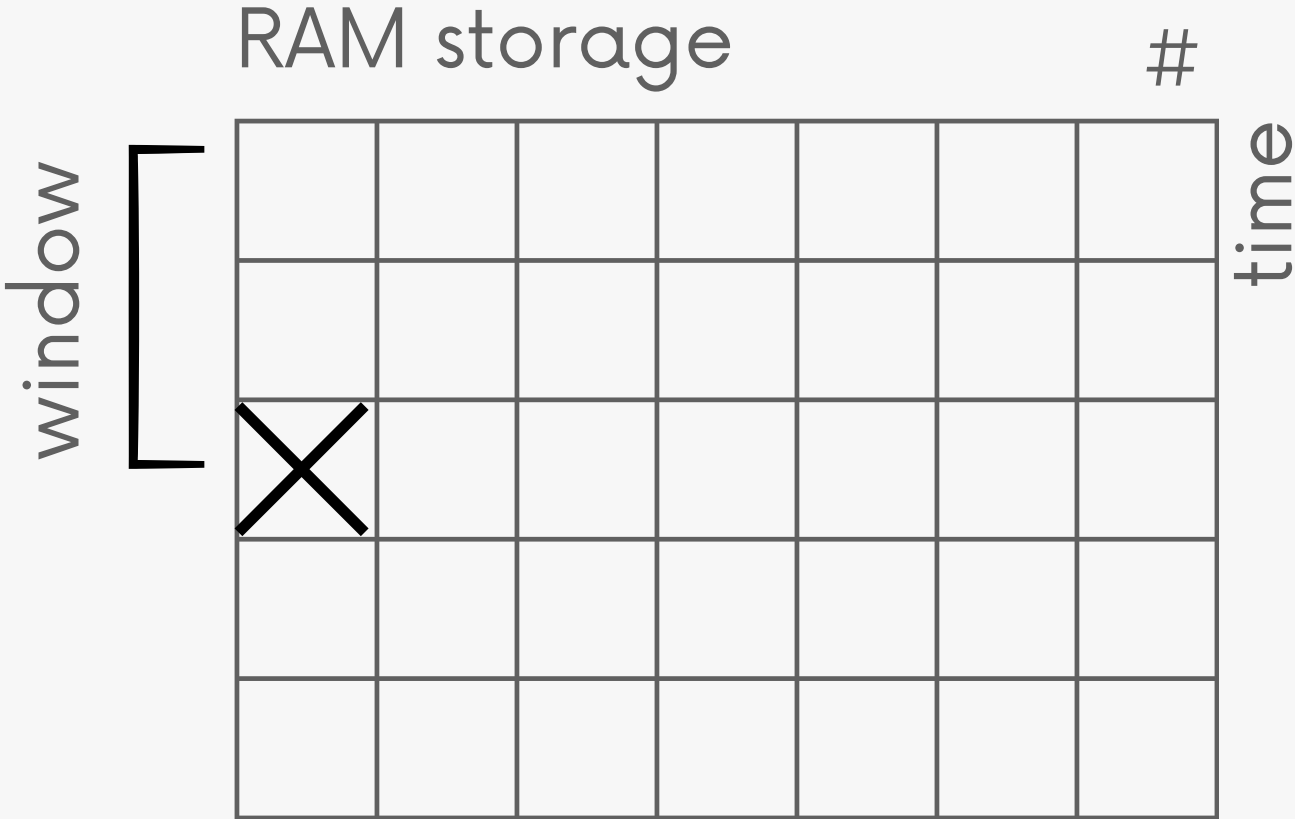

Ann-Kathrin Perrevoort PhD Thesis

**DAQ challenge: up to 3 links of continuous  
1.25 Gbit/s unsorted hit data**

# Readout of MuPix

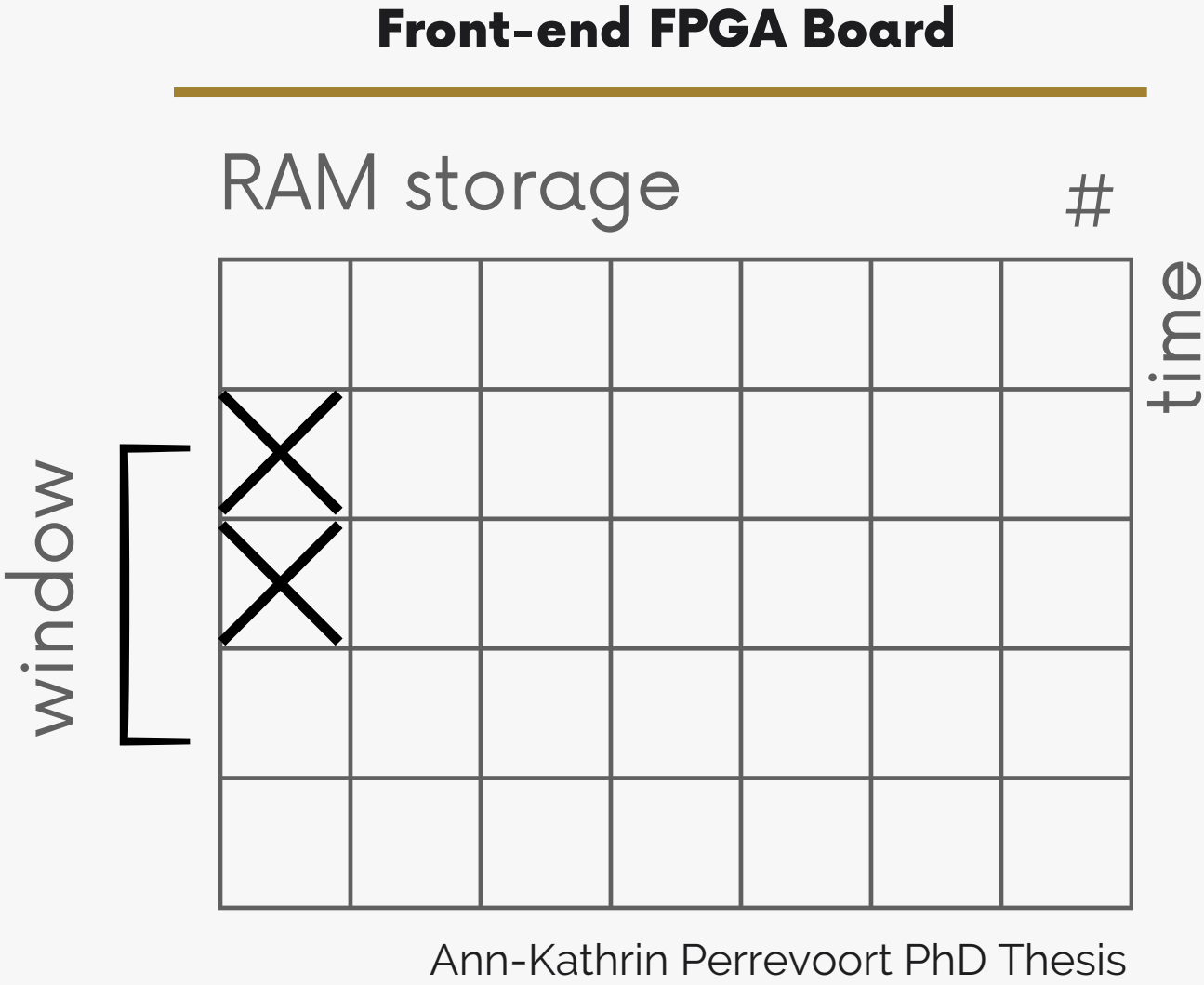
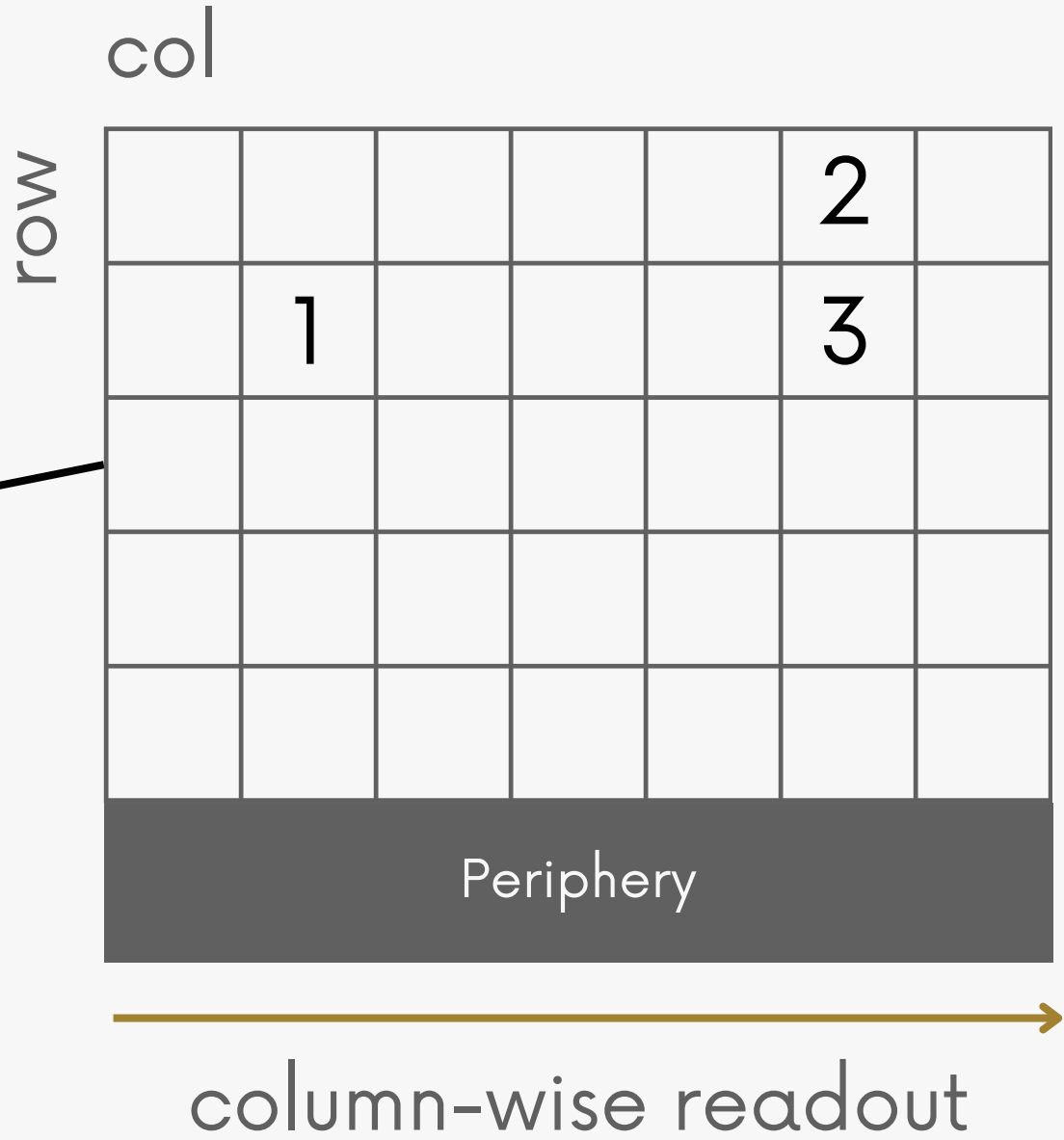
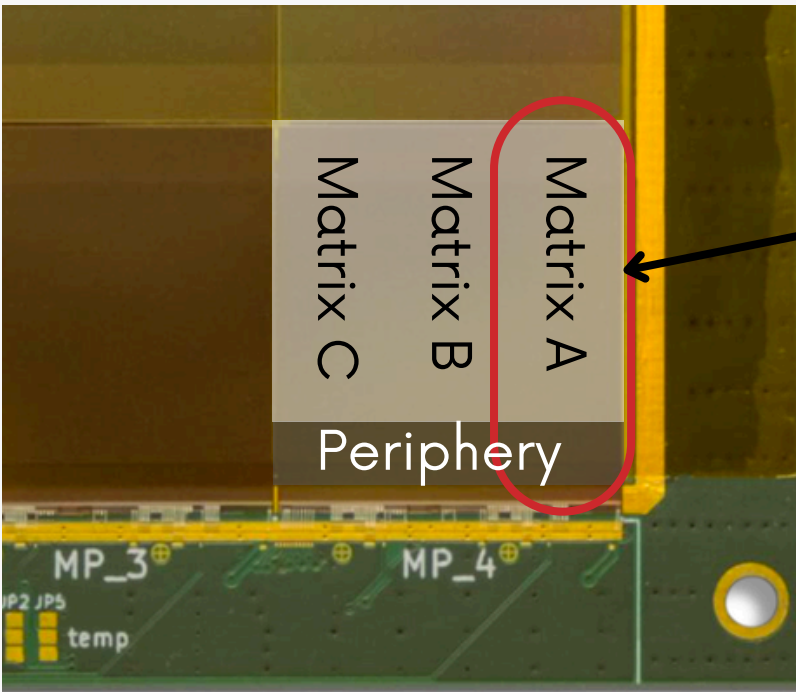

**DAQ challenge: up to 3 links of continuous  
1.25 Gbit/s unsorted hit data**

# Readout of MuPix

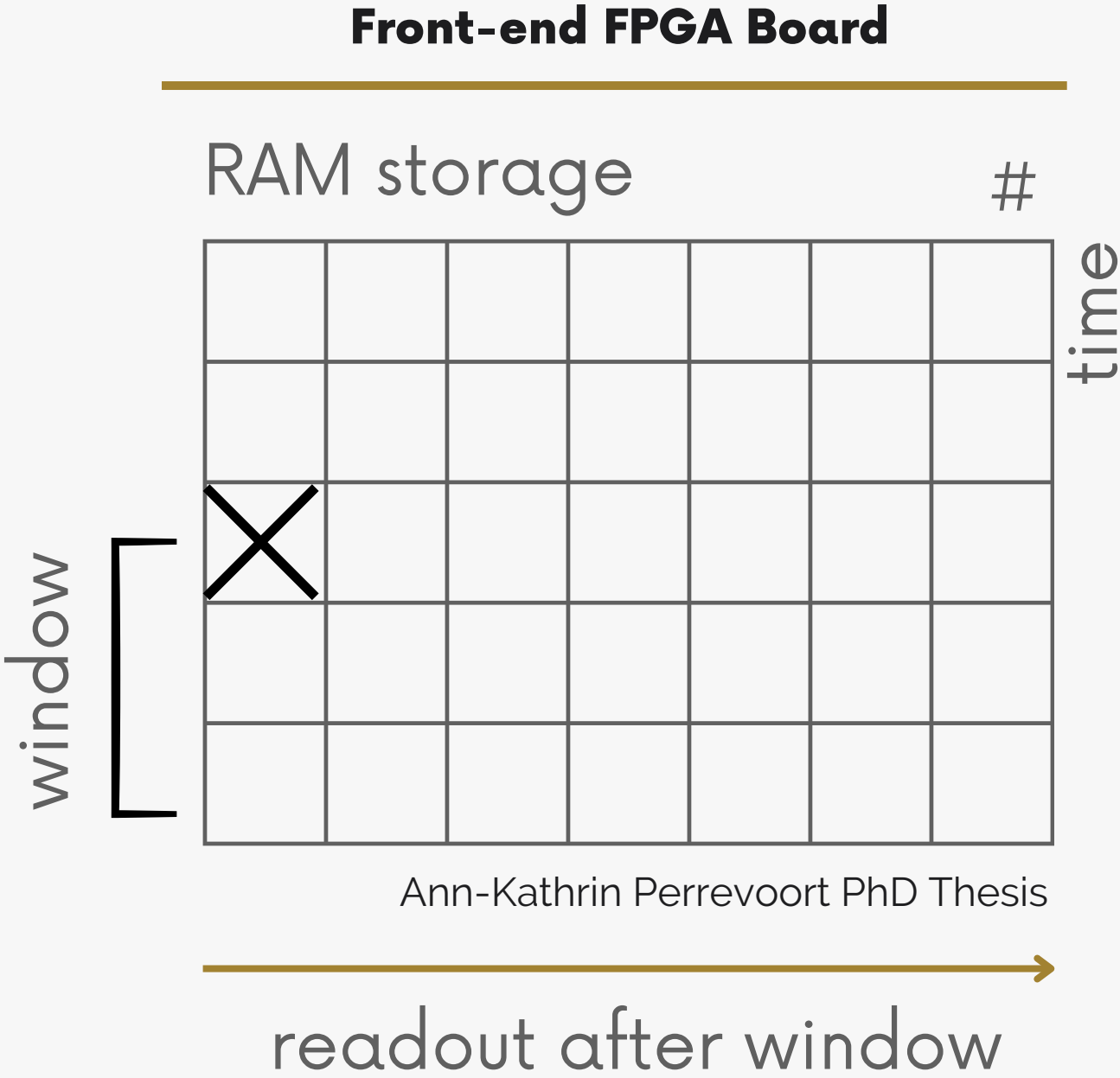
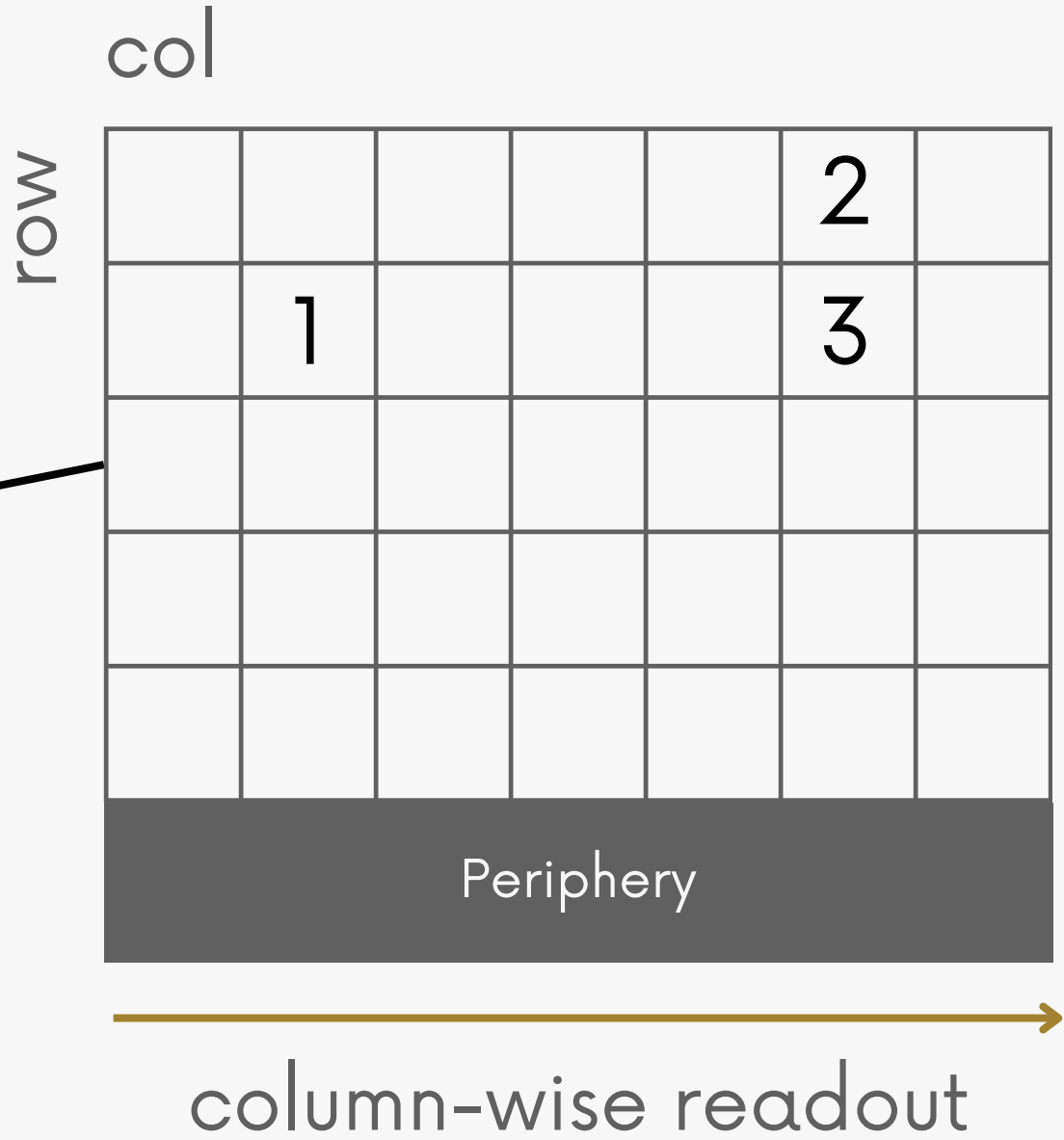
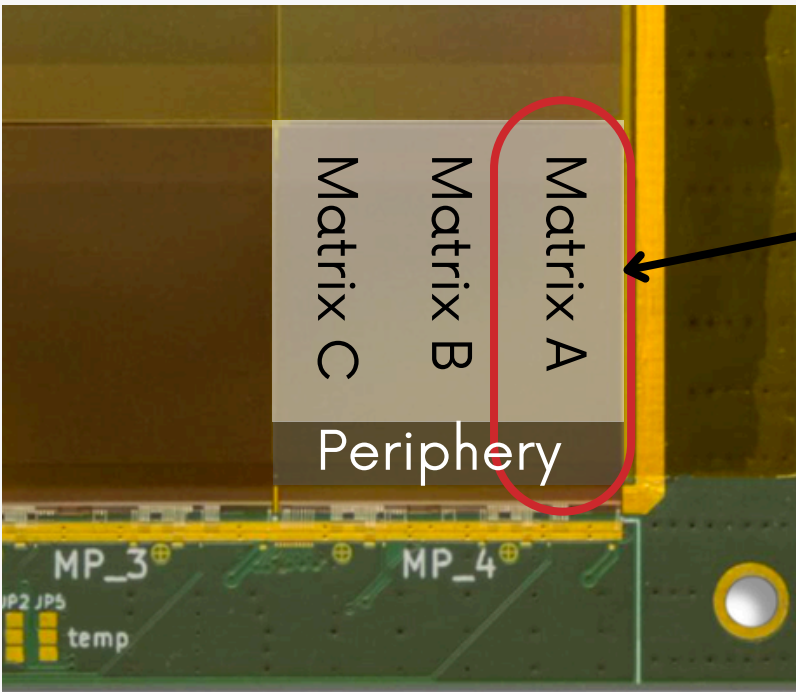

**DAQ challenge: up to 3 links of continuous 1.25 Gbit/s unsorted hit data**

# Readout of MuPix

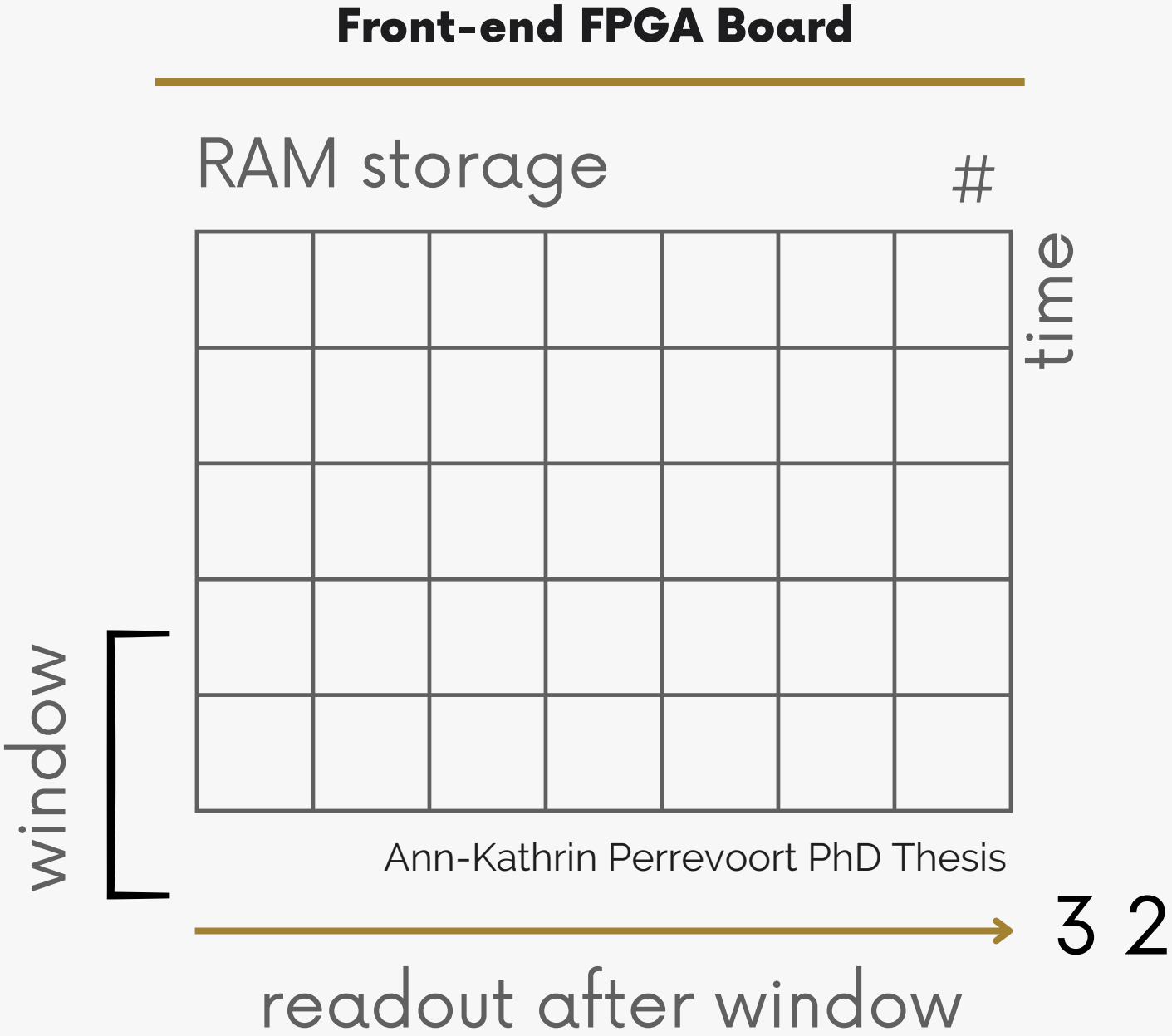
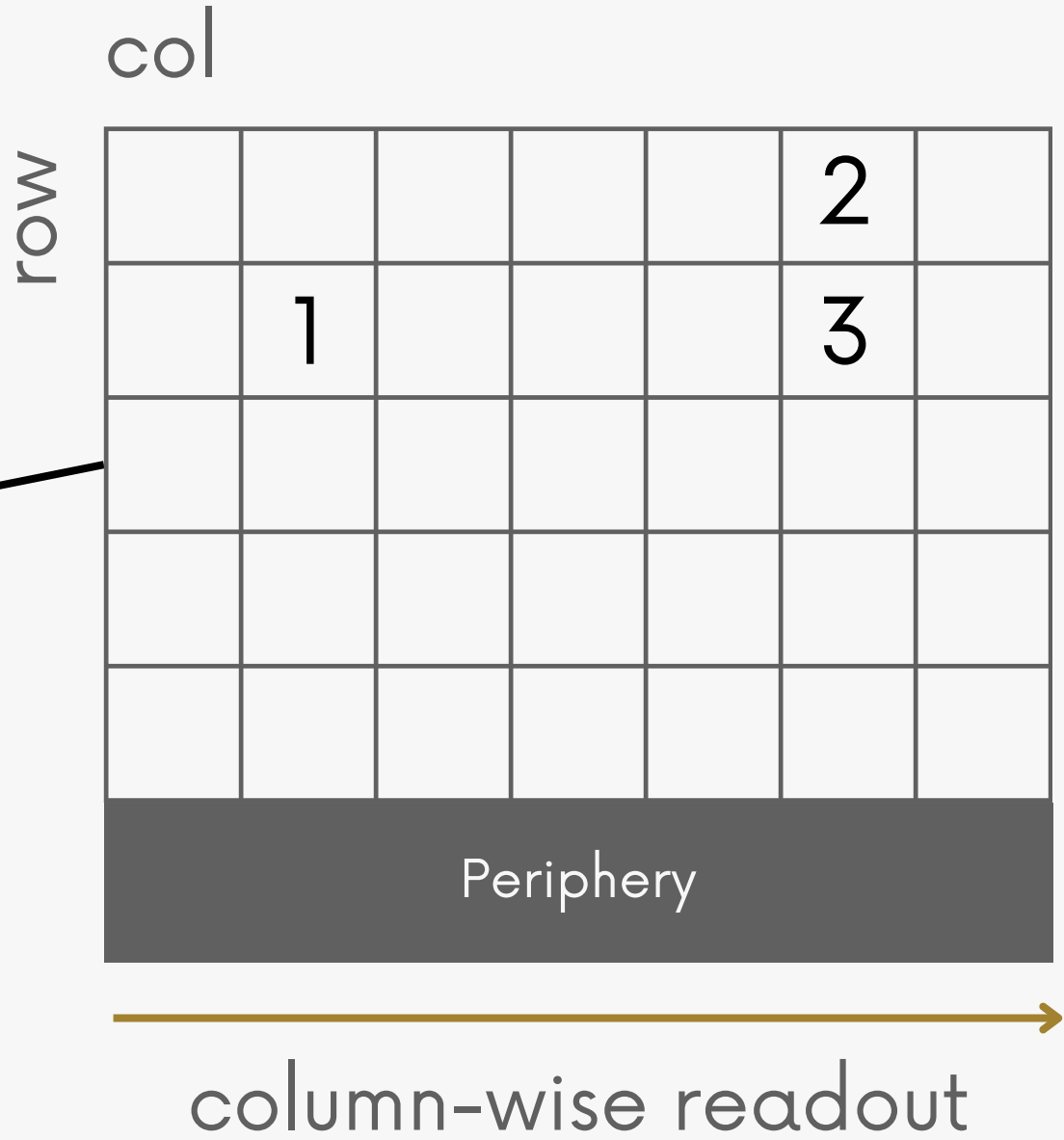
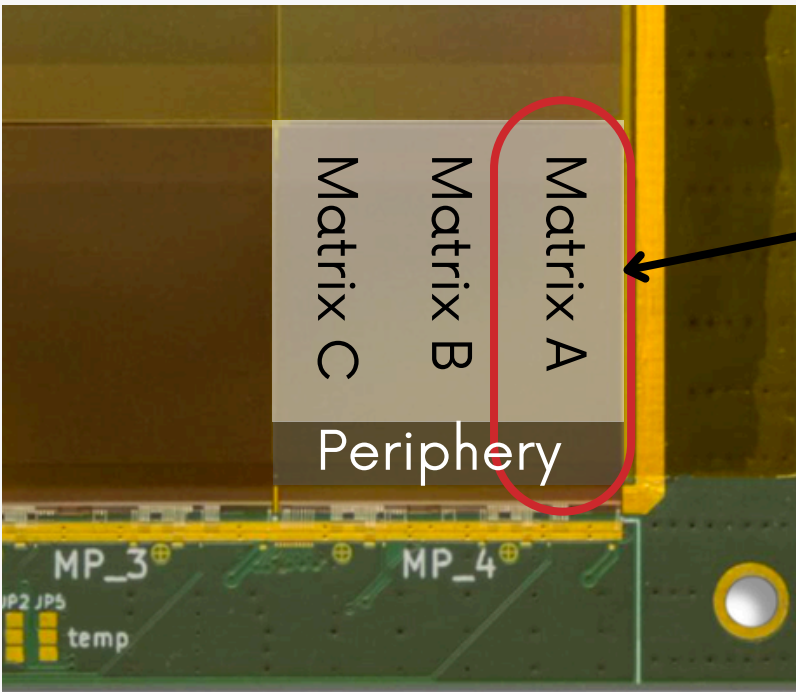

**DAQ challenge: up to 3 links of continuous 1.25 Gbit/s unsorted hit data**

# Front-end FPGA Board

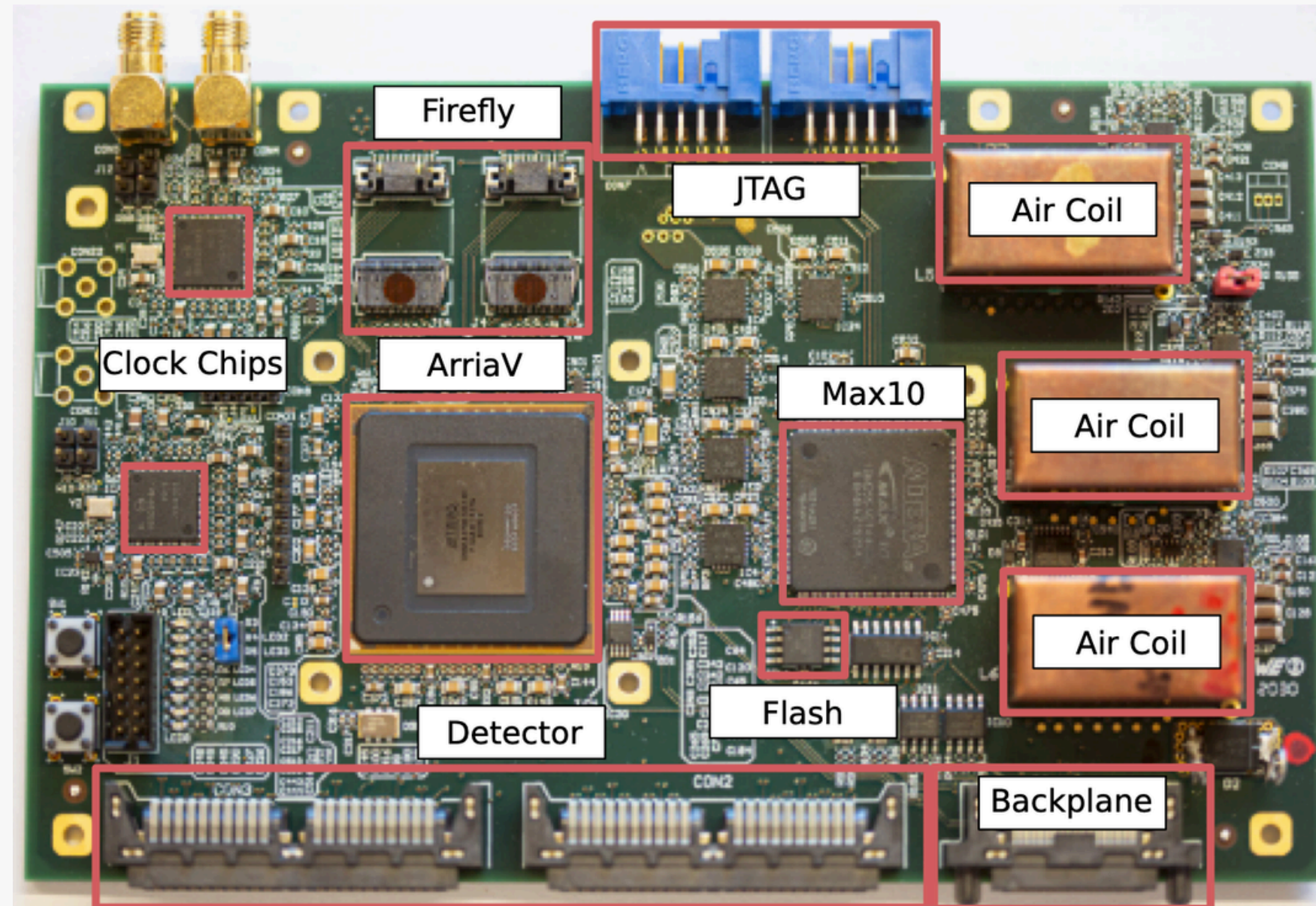

- Receives data from the detectors
- **Sorts** the **data** in time
- From electrical to optical
- **Send a package every  $16\mu s$**

# PC Interface FPGA Board

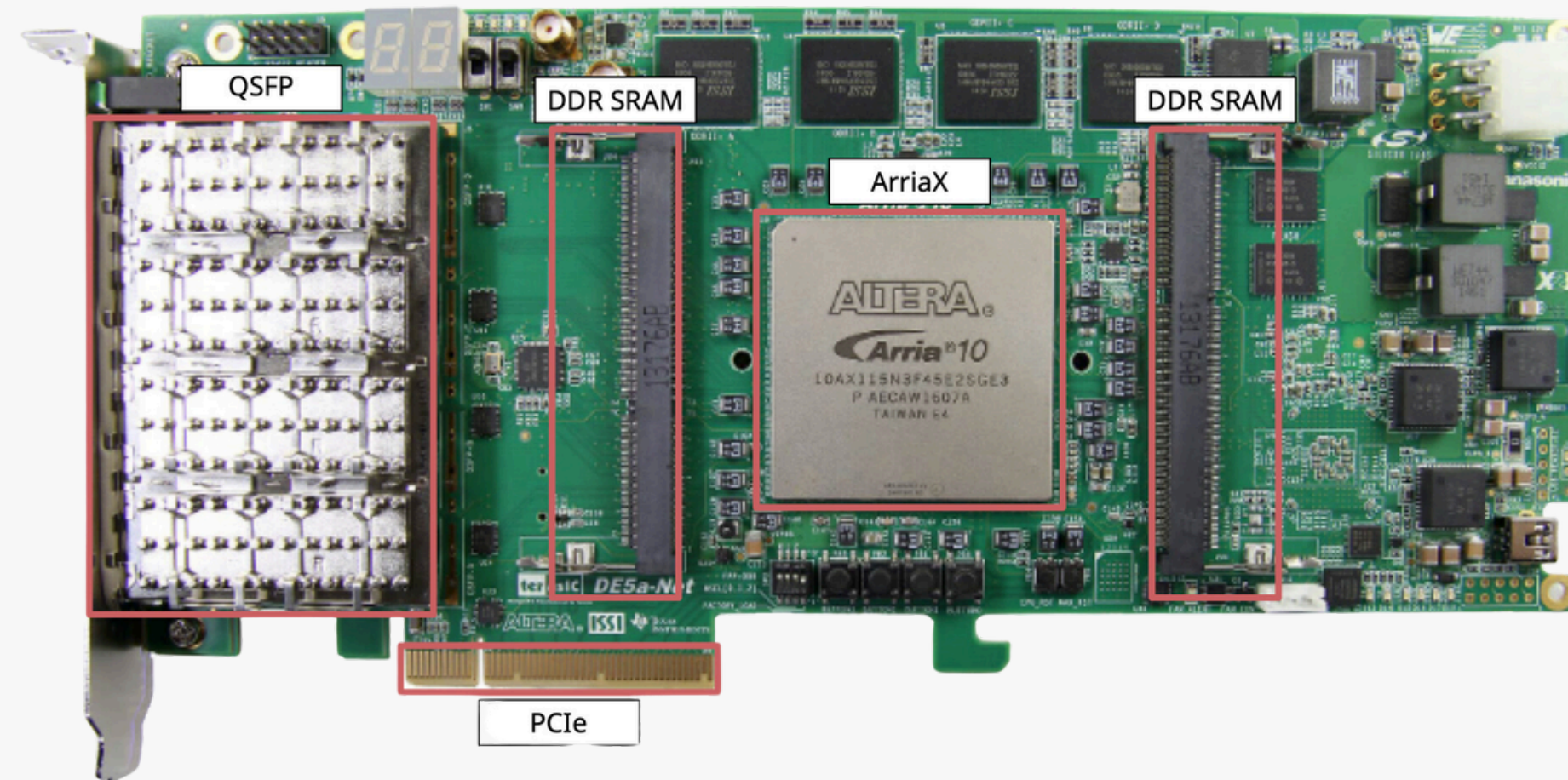

- Connected via 8-lane **PCIe** 3.0 to PC
- **Synchronisation** of different **FEBs**

- Terasic DE5e-Net board
- **DDR 3/4** memory for data buffering

# Pixel-based Detector - $xy$ - $\mu$ SR

Downstream  
layers

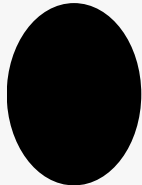

Sample

Upstream  
layers



# Pixel-based Detector - $xy$ - $\mu$ SR

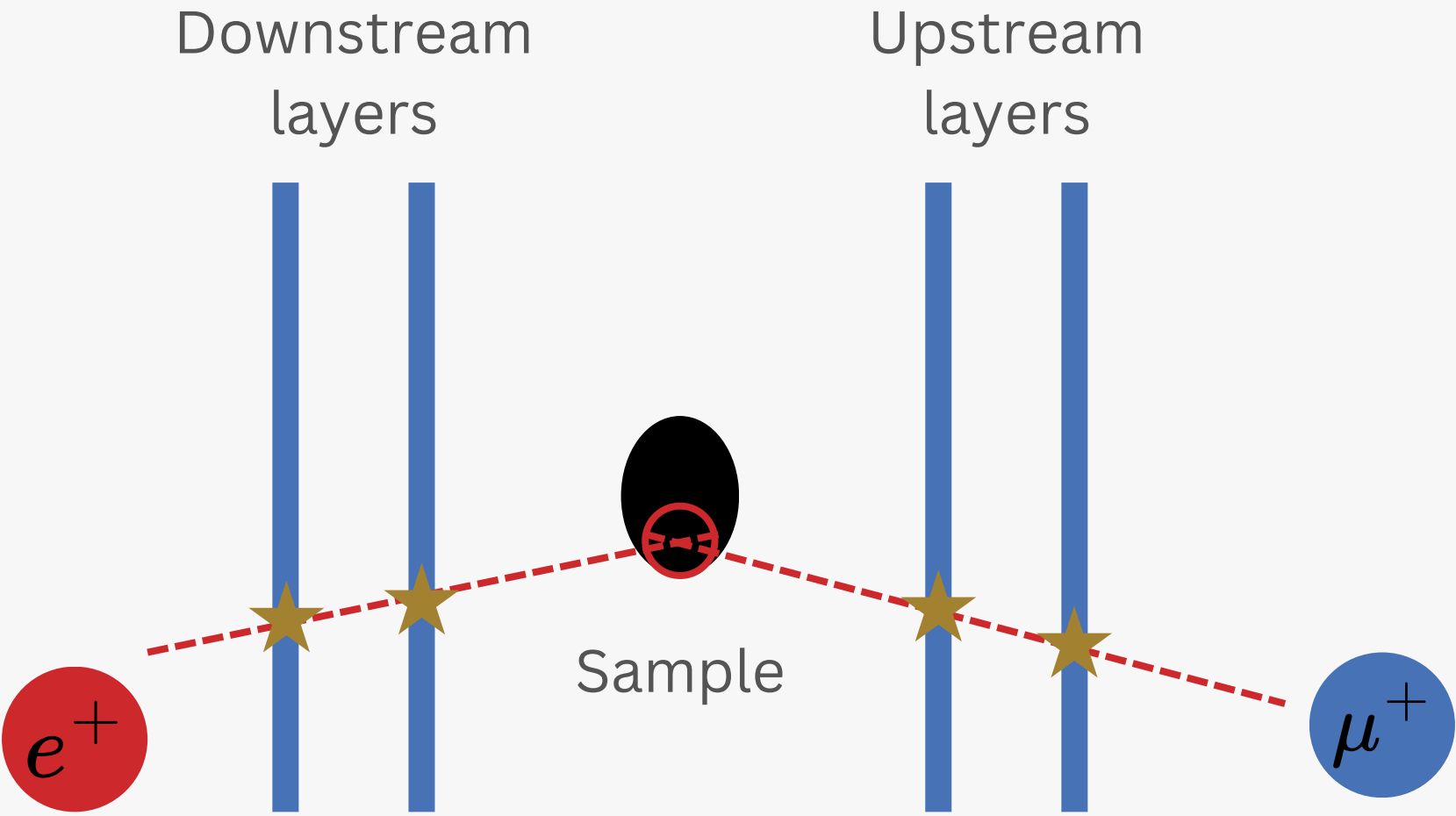

- 2 layer **tracking** using pixel sensors
- **Vertex** reconstruction with [corrvreckan](#) 

# Pixel-based Detector - $xy$ - $\mu$ SR

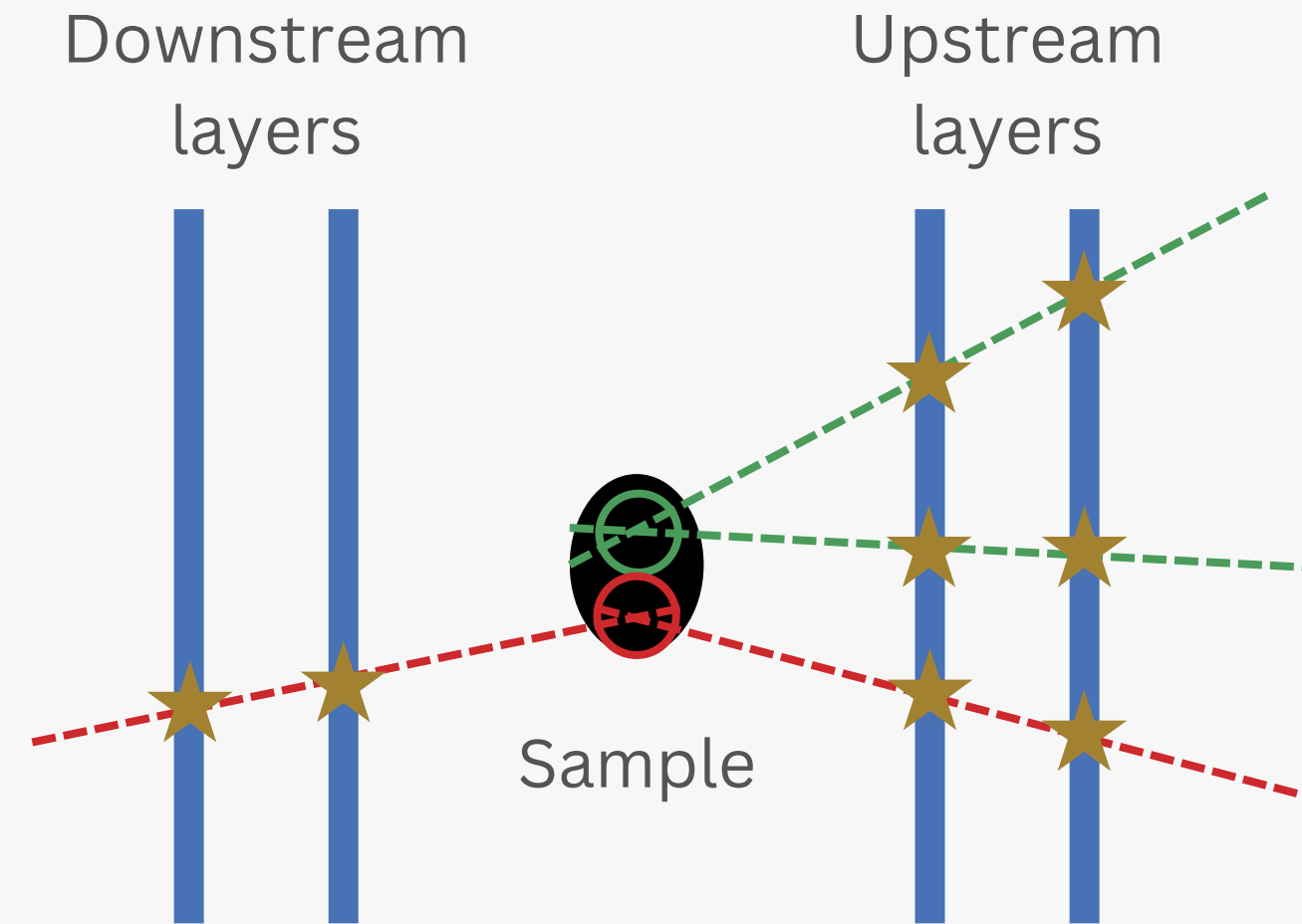

- 2 layer **tracking** using pixel sensors

- **Vertex** reconstruction with [corrvreckan](#) 

- **Increase** muon rate by **10 - 100** times
- Several **smaller** samples at once
- Probe **local** domains of the samples

# Pixel-based Detector - xy- $\mu$ SR

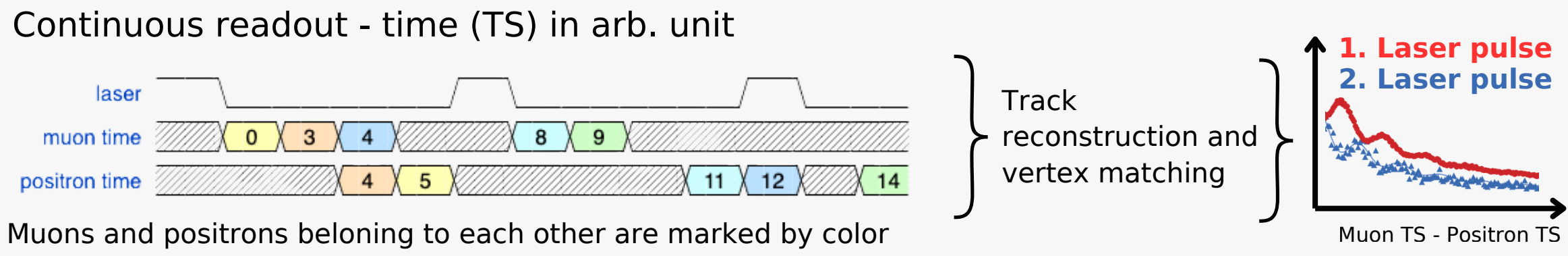
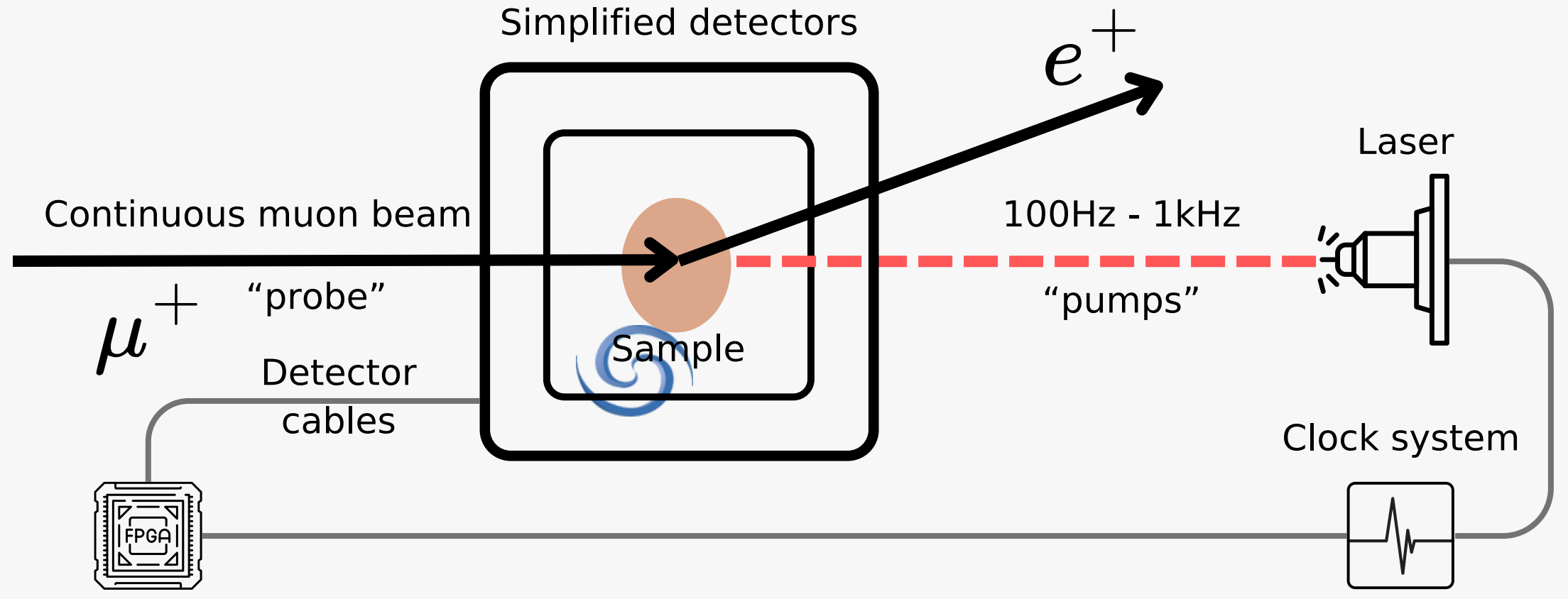

- Perform **triggerless** pump-probe xy- $\mu$ SR
- **Sort** muons according to their arrival time **relative** to the pump stimulus

# TABLE OF CONTENTS

01 | MuSR at PSI

02 | HV-MAPS & DAQ

03 | Results

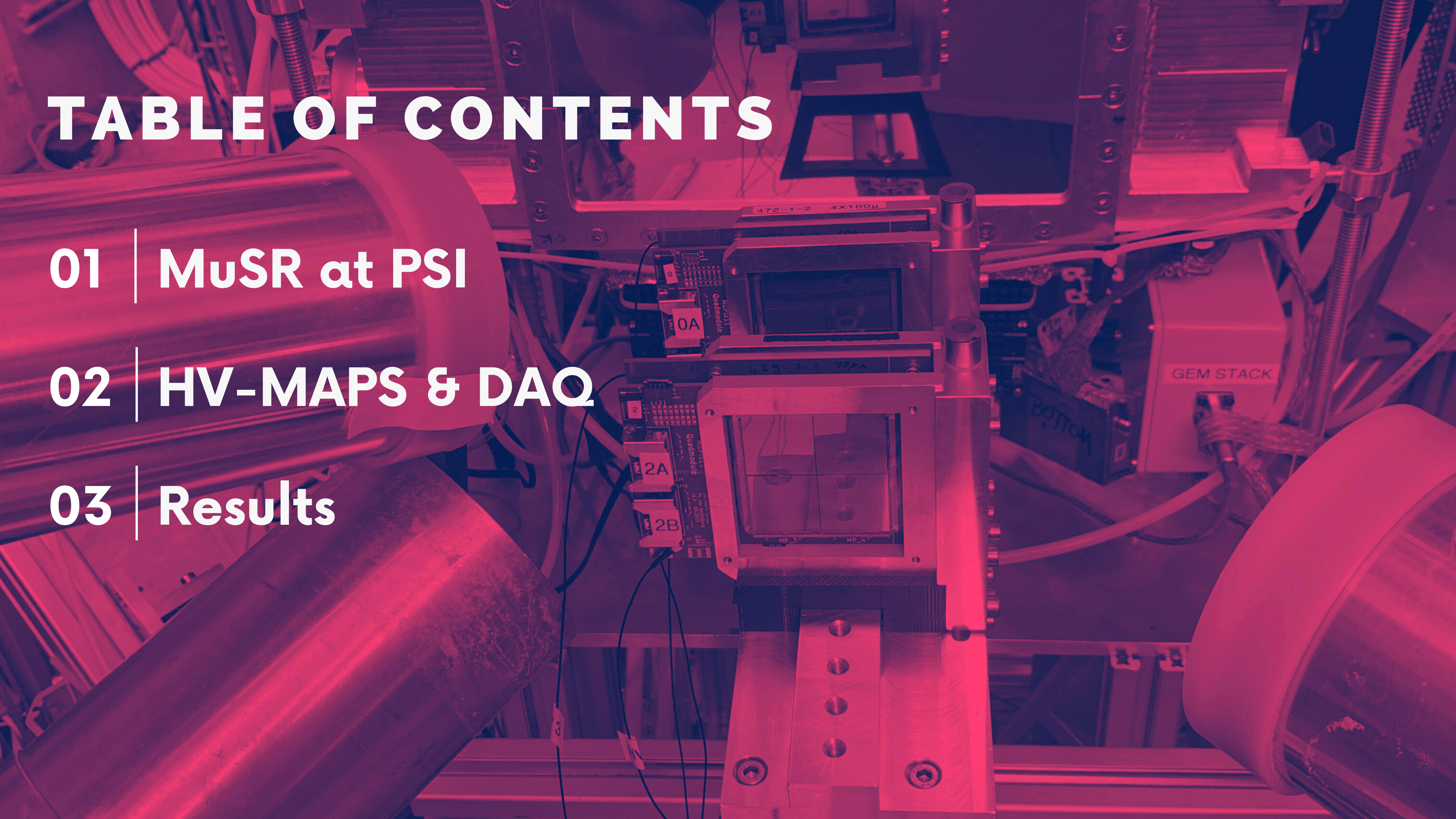

# Testbeam Telescope

- Transversal polarized surface muon beam @ PSI - PiE3 beamline (09/2023, 09/2024)
- Goals:
  - Measuring vertex resolution  $< 1$  mm
  - Measuring spin rotation
  - Mapping magnetic field in sample



# Setup 09/2023

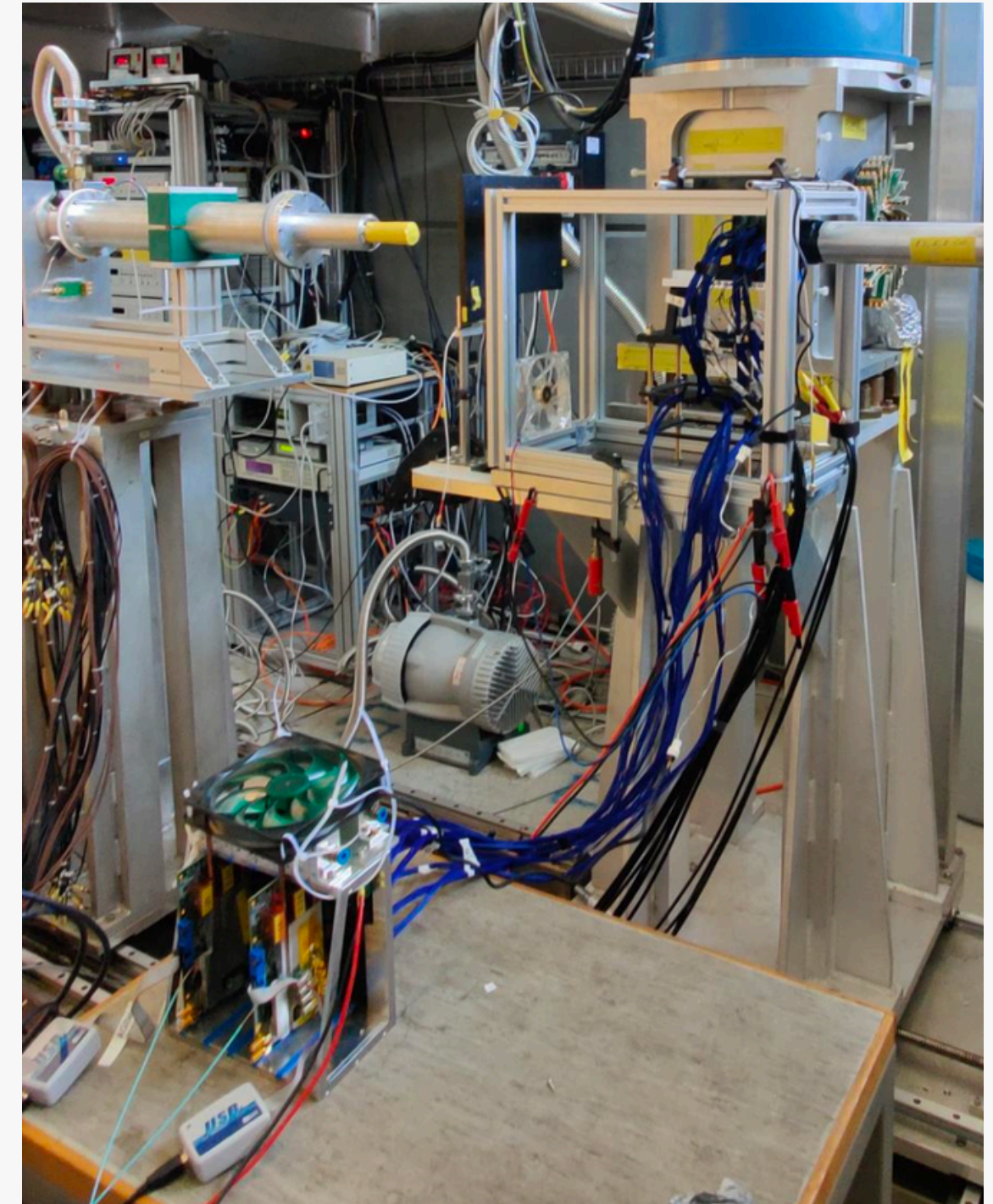

Image from Lukas Mandok BTTB Talk

# Setup 09/2023

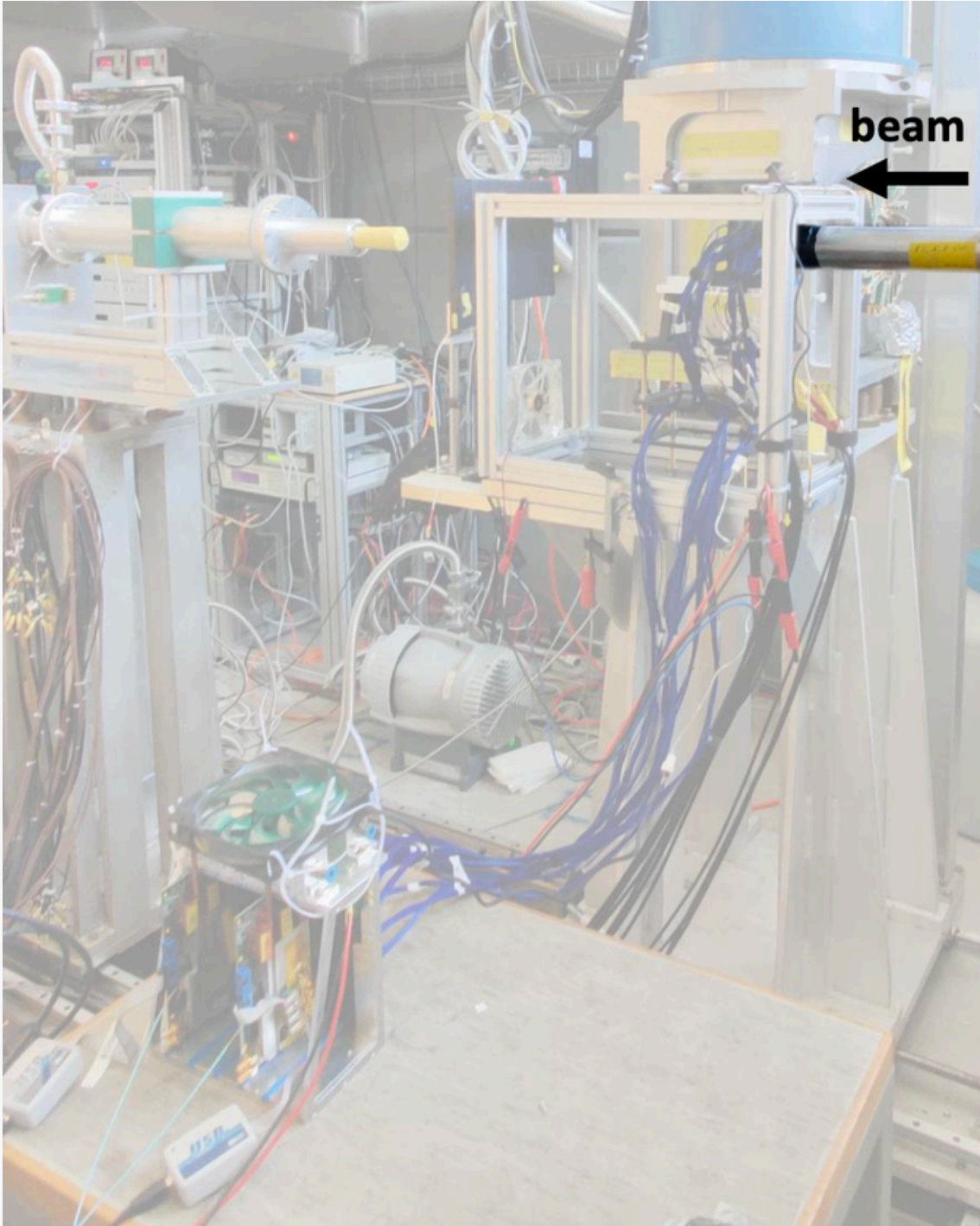
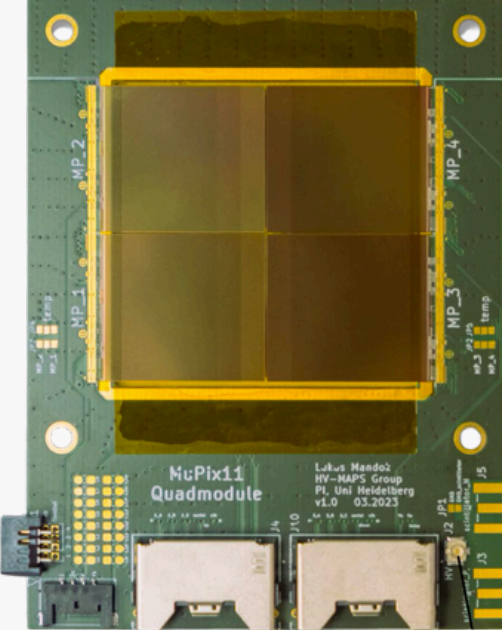

Image from Lukas Mandok BTTB Talk

# Setup 09/2023

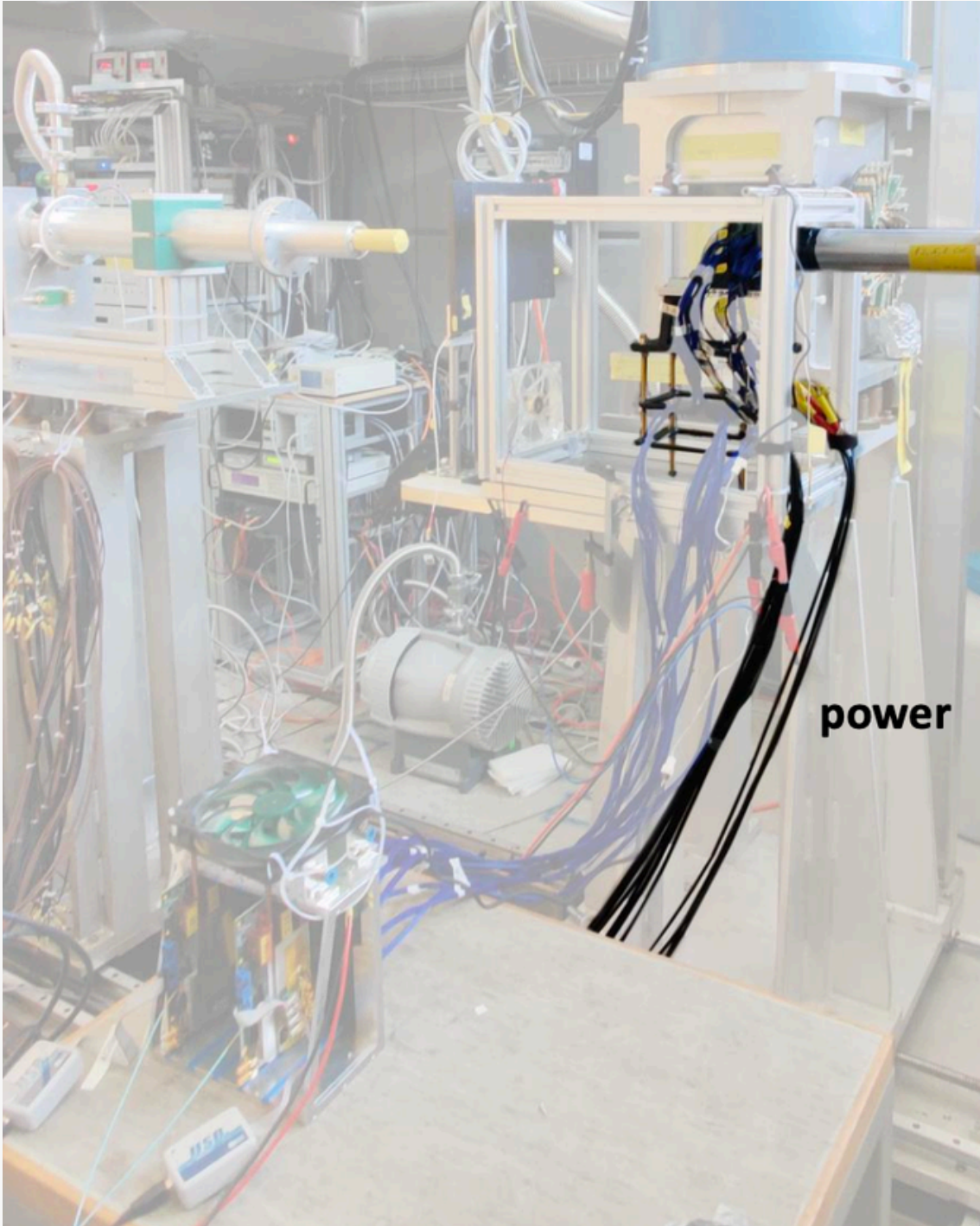
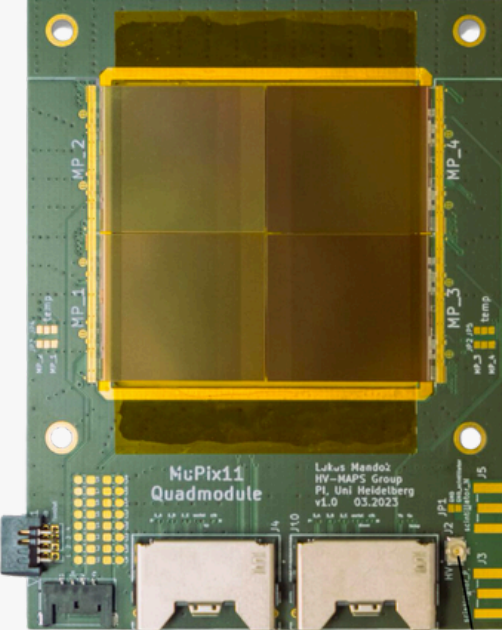

Image from Lukas Mandok BTTB Talk

# Setup 09/2023

## DAQ

- 3 data-links per sensor × 1.25 Gbps

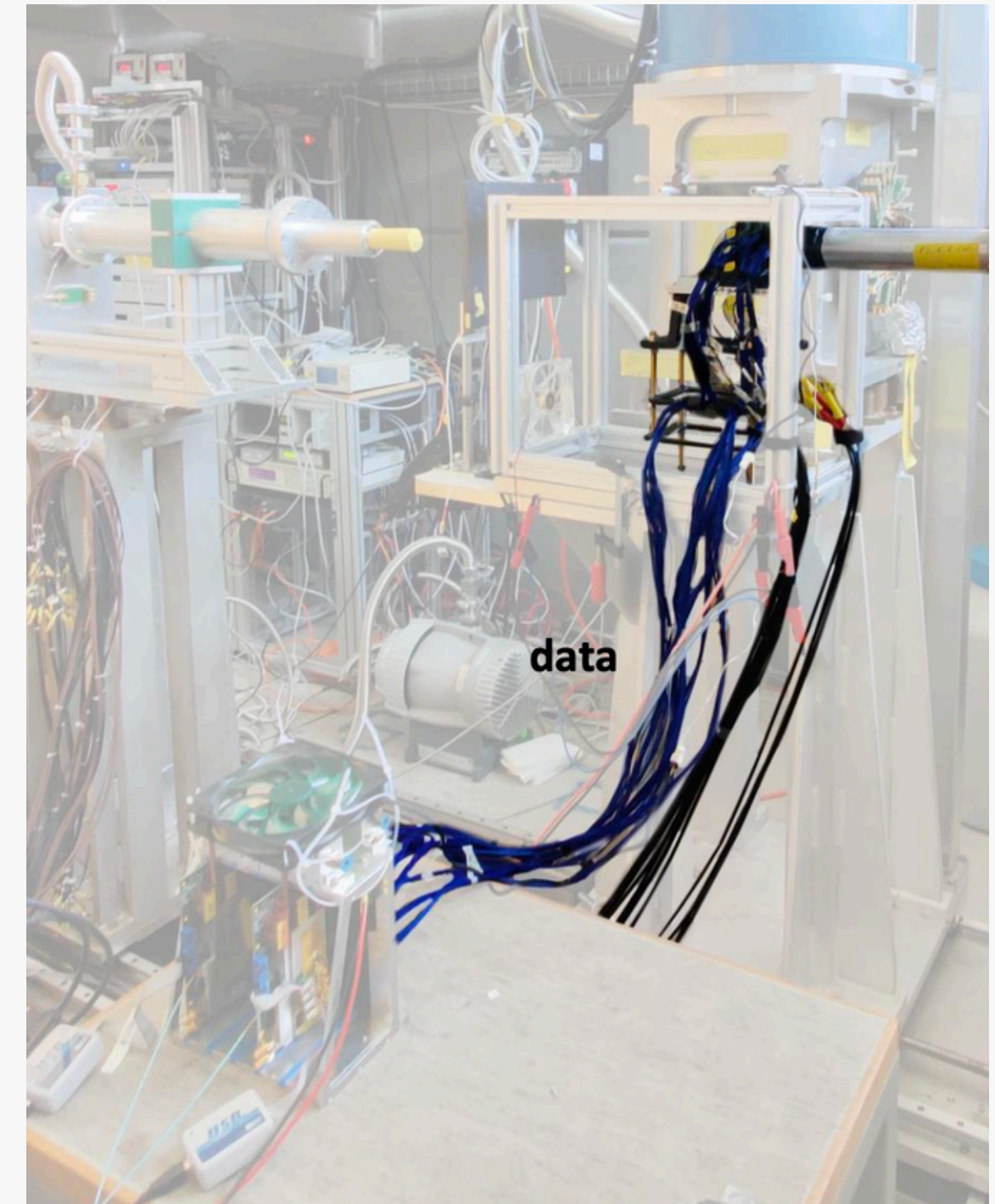
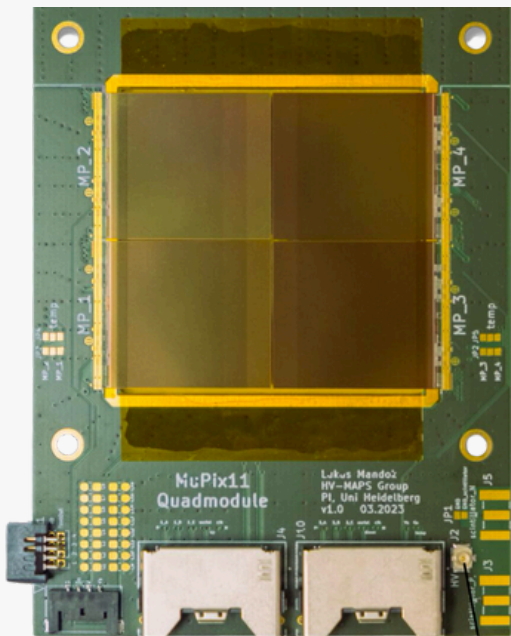

Image from Lukas Mandok BTTB Talk

# Setup 09/2023

## DAQ

- 3 data-links per sensor × 1.25 Gbps
- Mu3e soft- and hardware

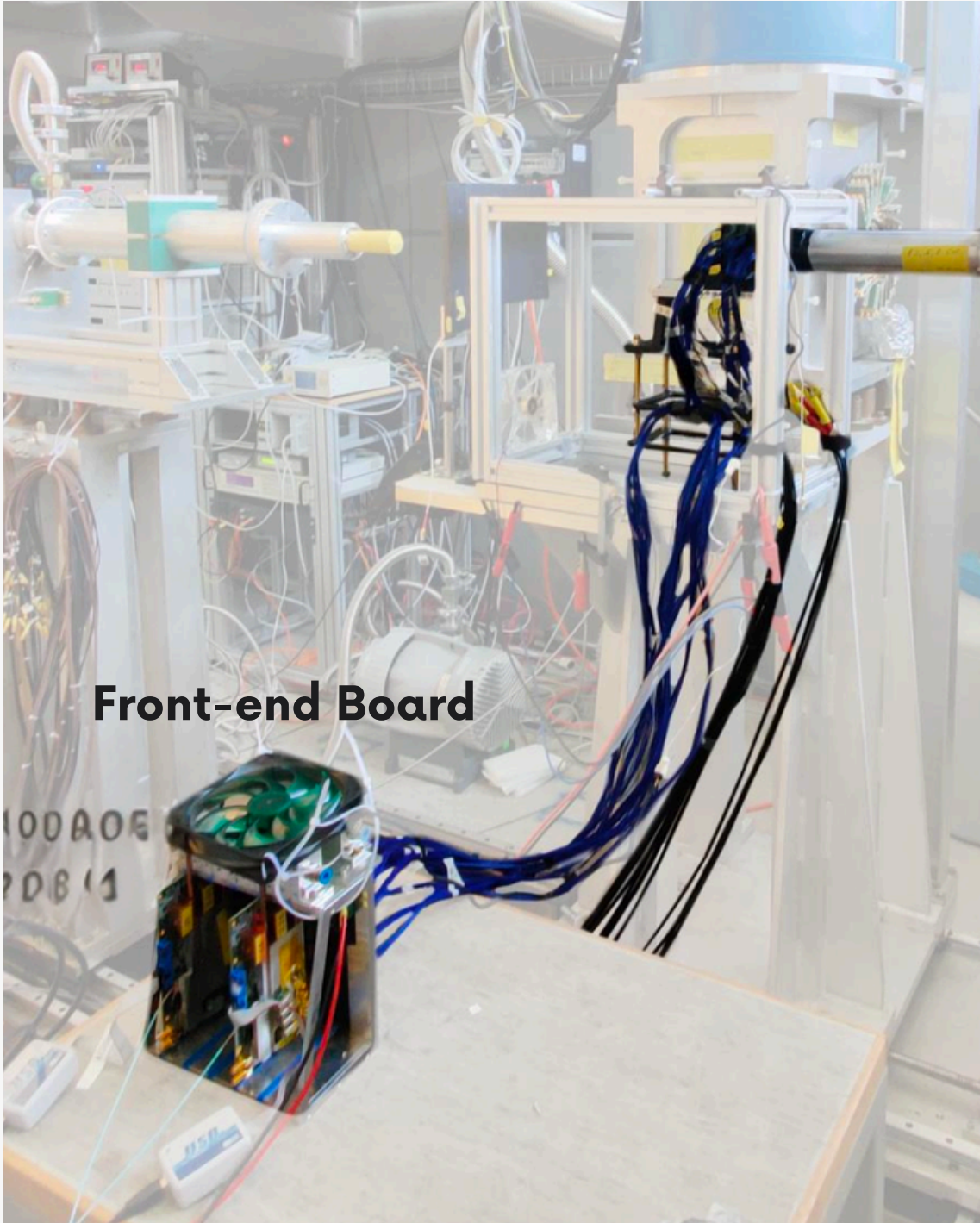
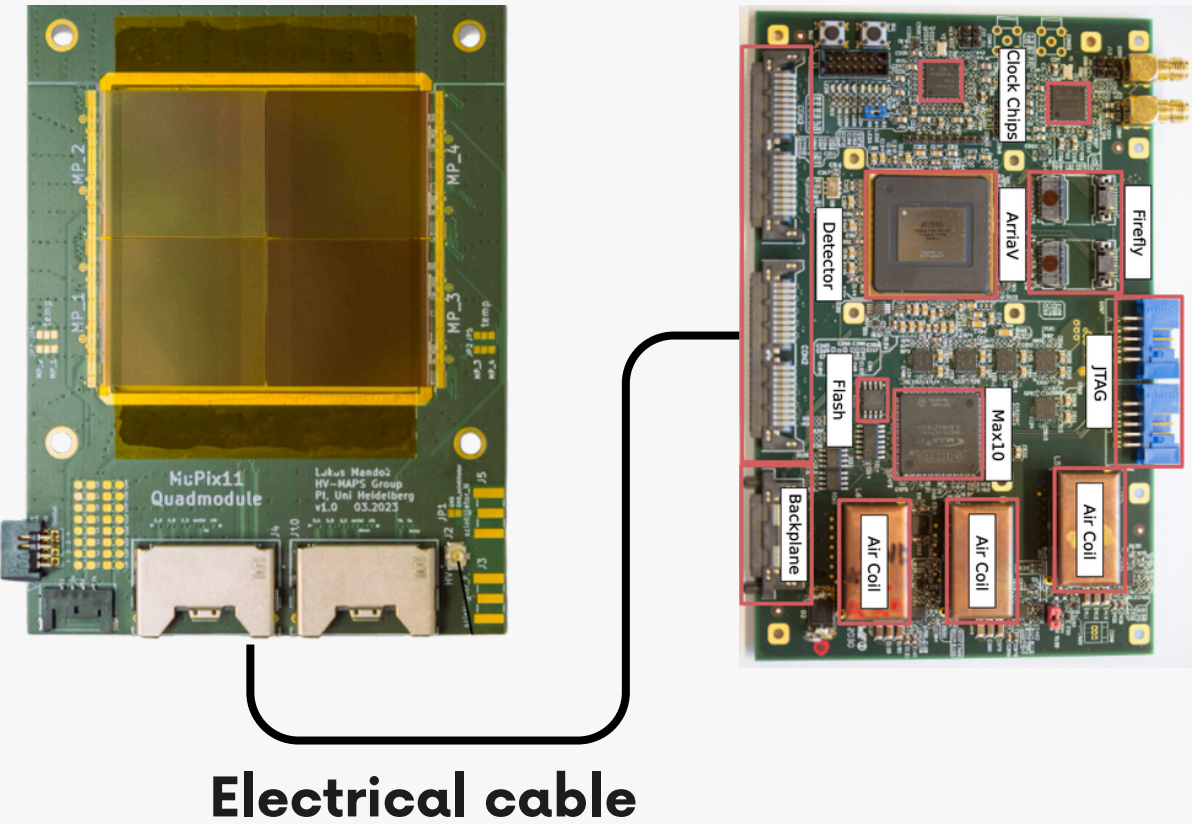
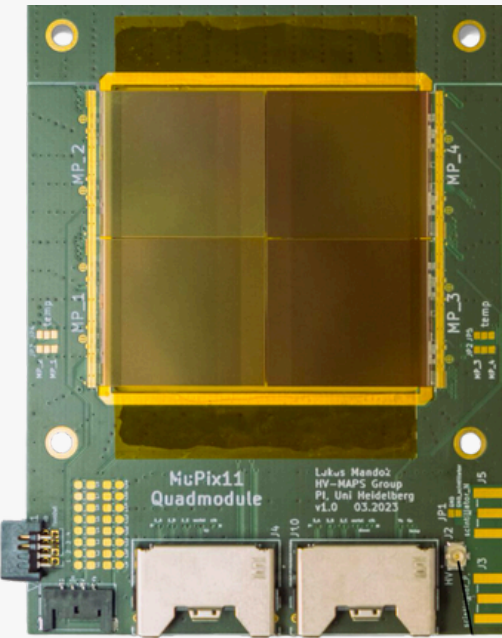

Image from Lukas Mandok BTTB Talk

# Setup 09/2023

## DAQ

- 3 data-links per sensor × 1.25 Gbps
- Mu3e soft- and hardware



Electrical cable

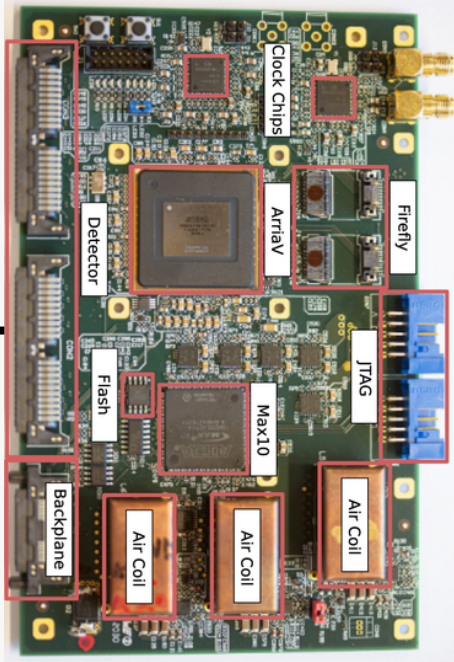

Optical cable

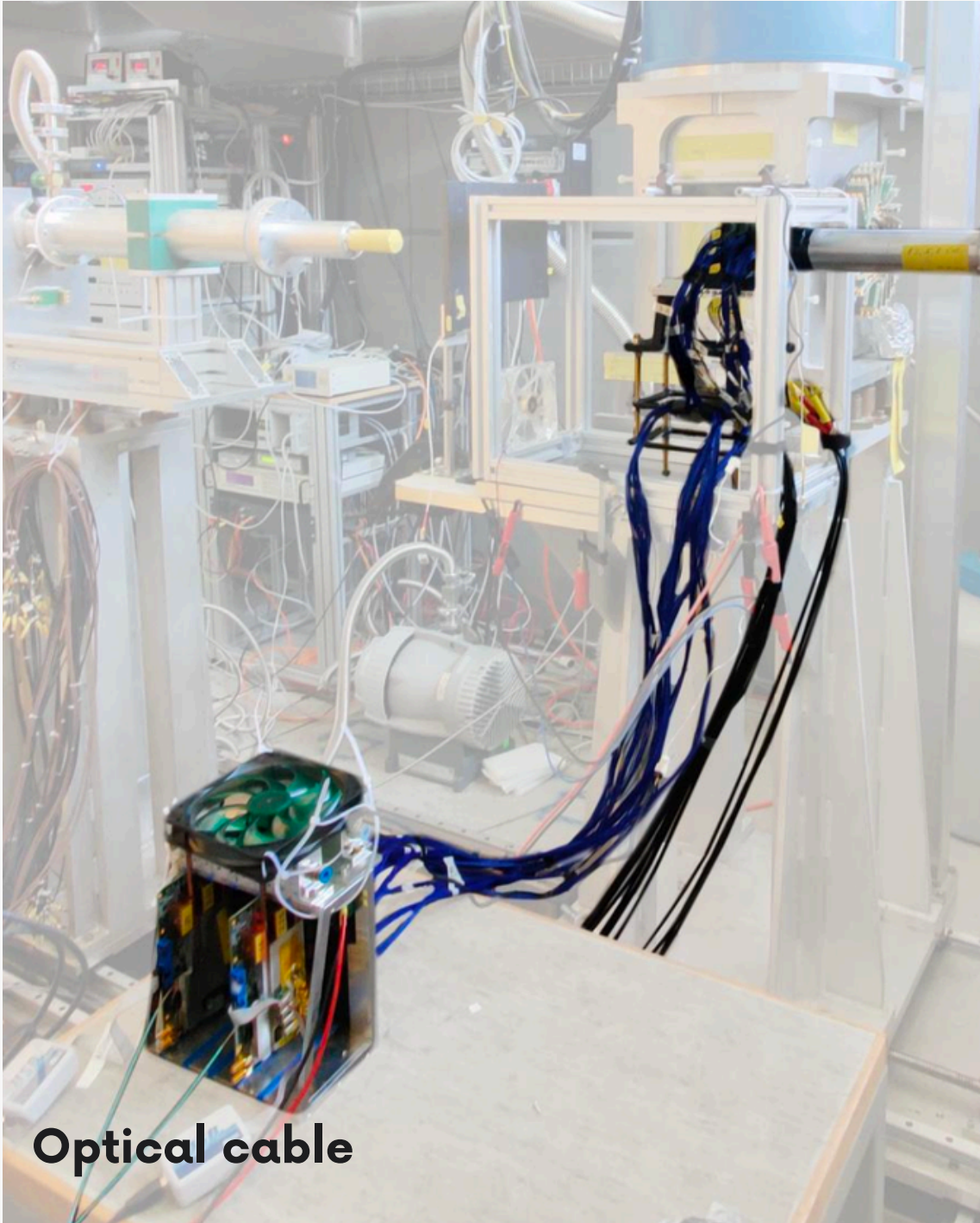
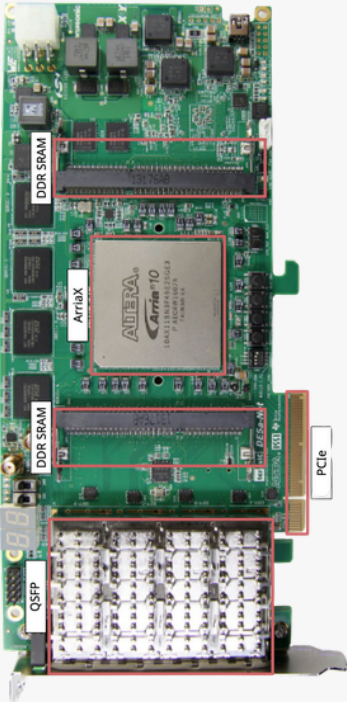

Optical cable

Image from Lukas Mandok BTTB Talk

# Setup 09/2023

## DAQ

- 3 data-links per sensor × 1.25 Gbps
- Mu3e soft- and hardware

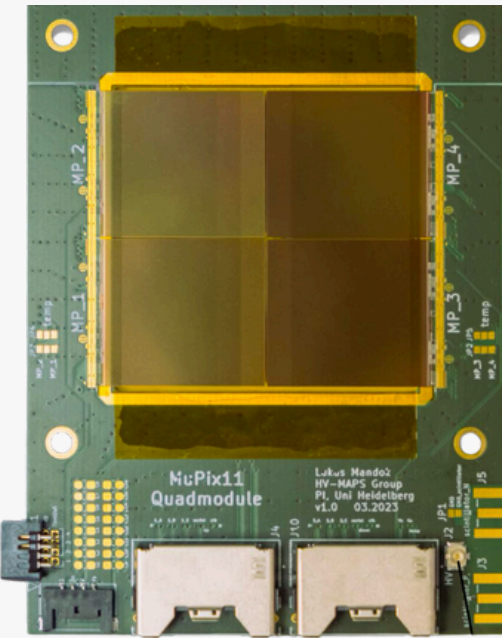

Electrical cable

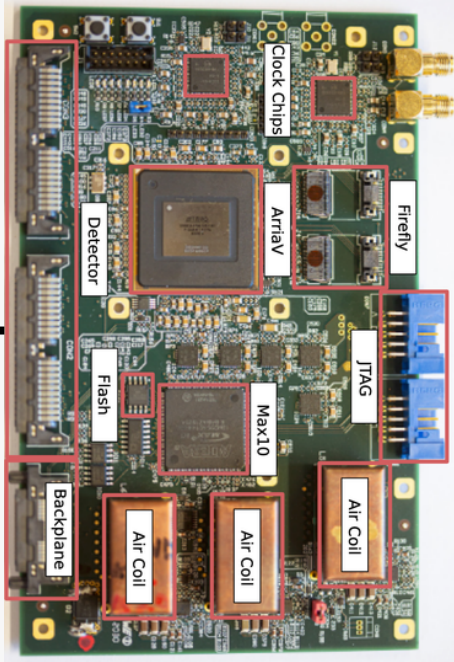

Optical cable

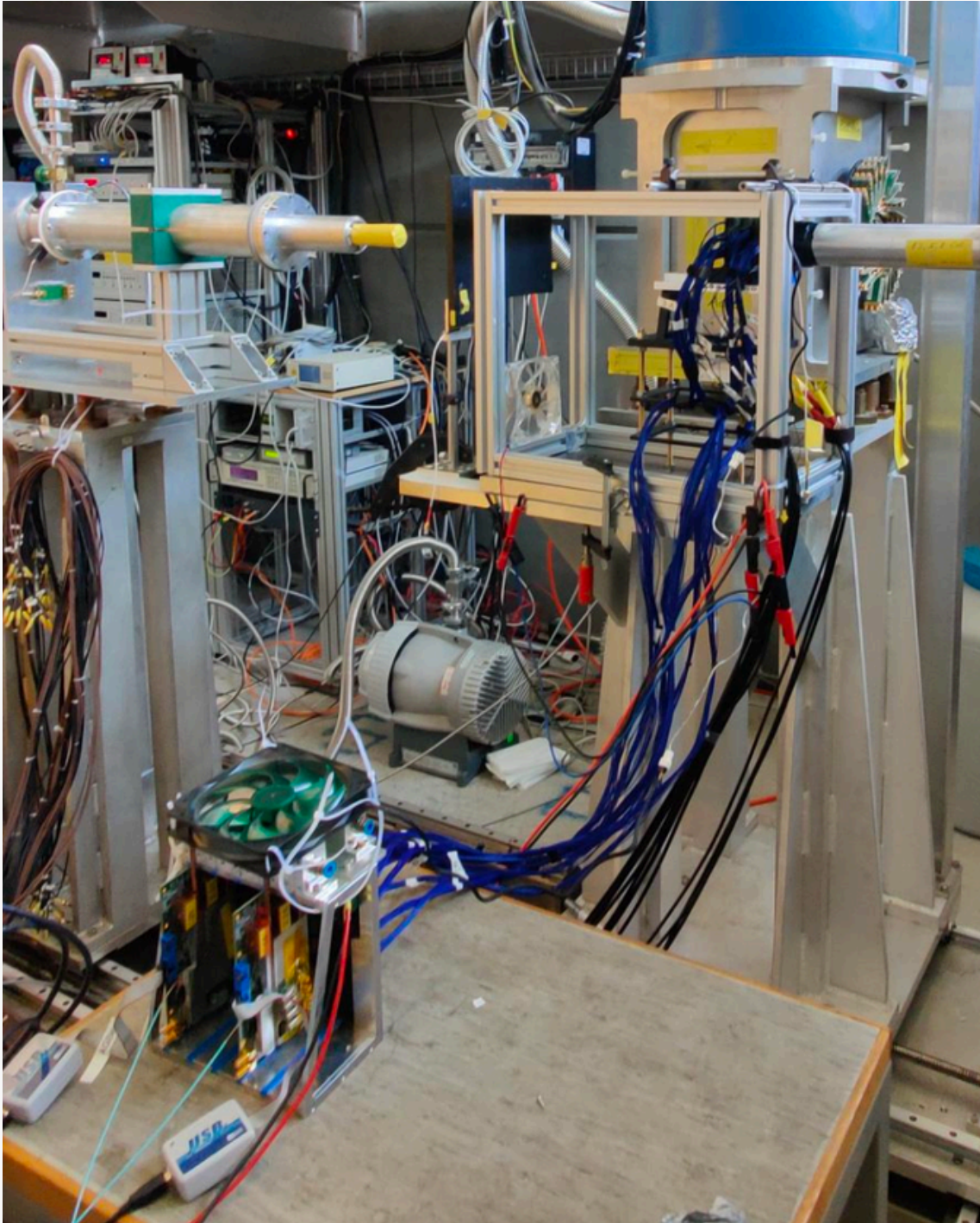
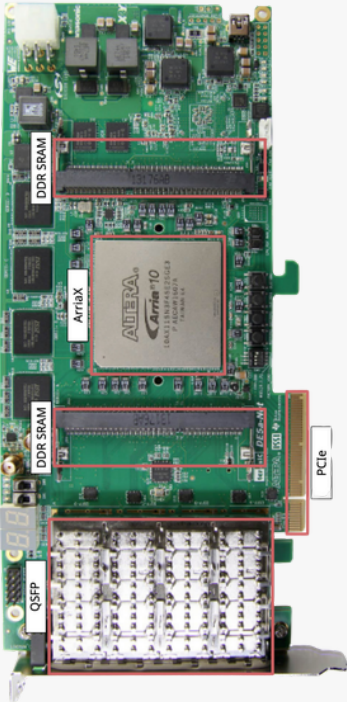
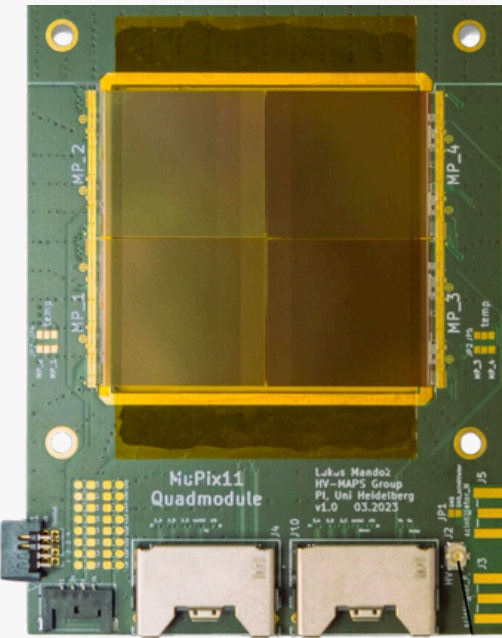

Image from Lukas Mandok BTTB Talk

# Setup 09/2023

## DAQ

- 3 data-links per sensor × 1.25 Gbps
- Mu3e soft- and hardware
- Light sensitive sensors



Electrical cable

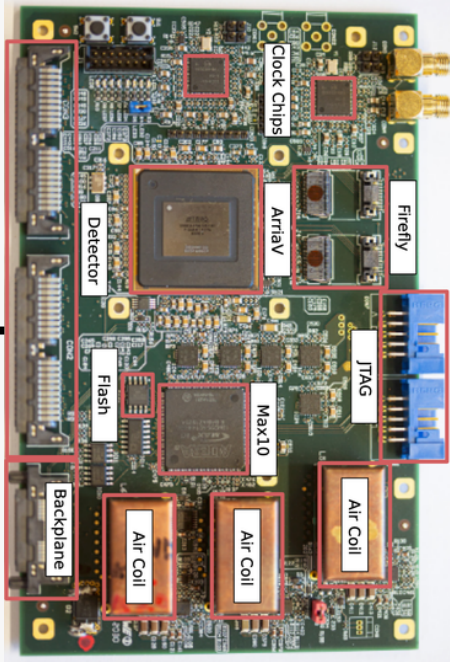

Optical cable

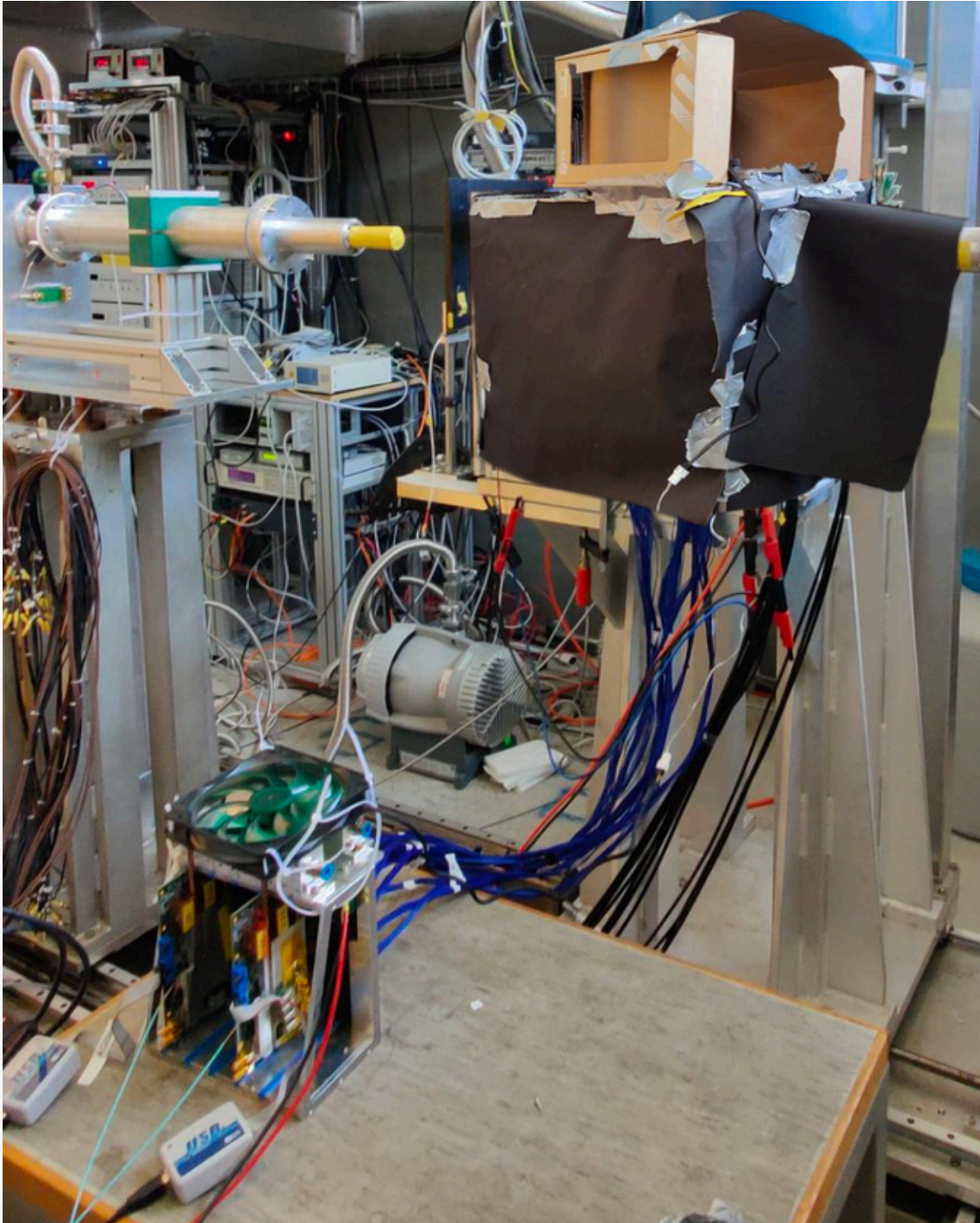
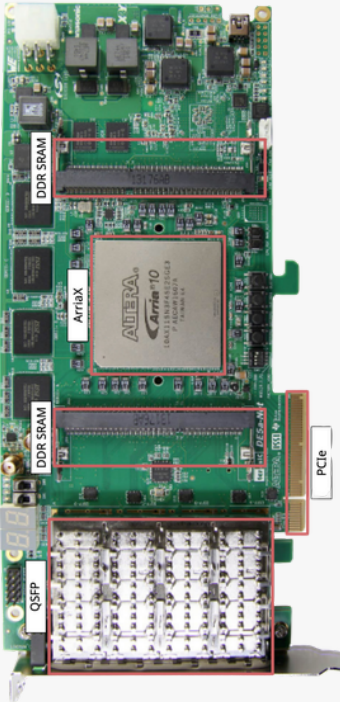
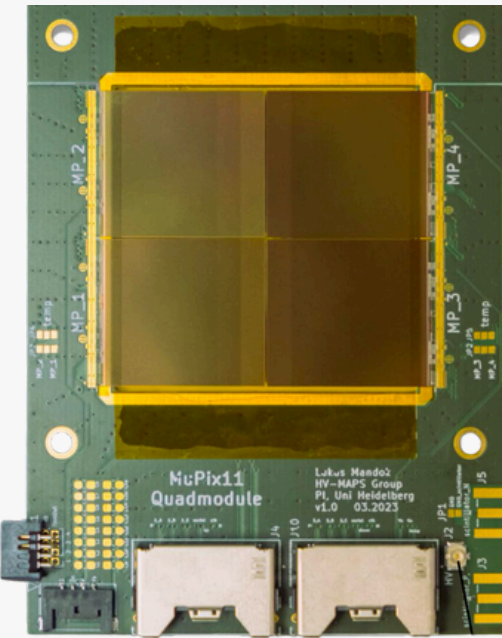

Image from Lukas Mandok BTTB Talk

# Setup 09/2024

## DAQ

- 3 data-links per sensor  $\times$  1.25 Gbps
- Mu3e soft- and hardware
- Light sensitive sensors



Electrical cable

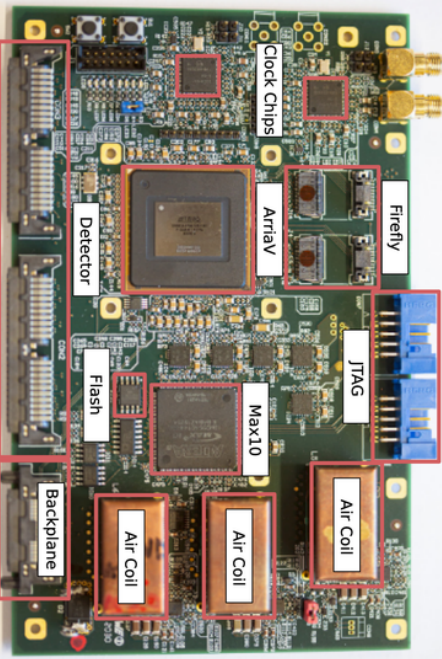

Optical cable

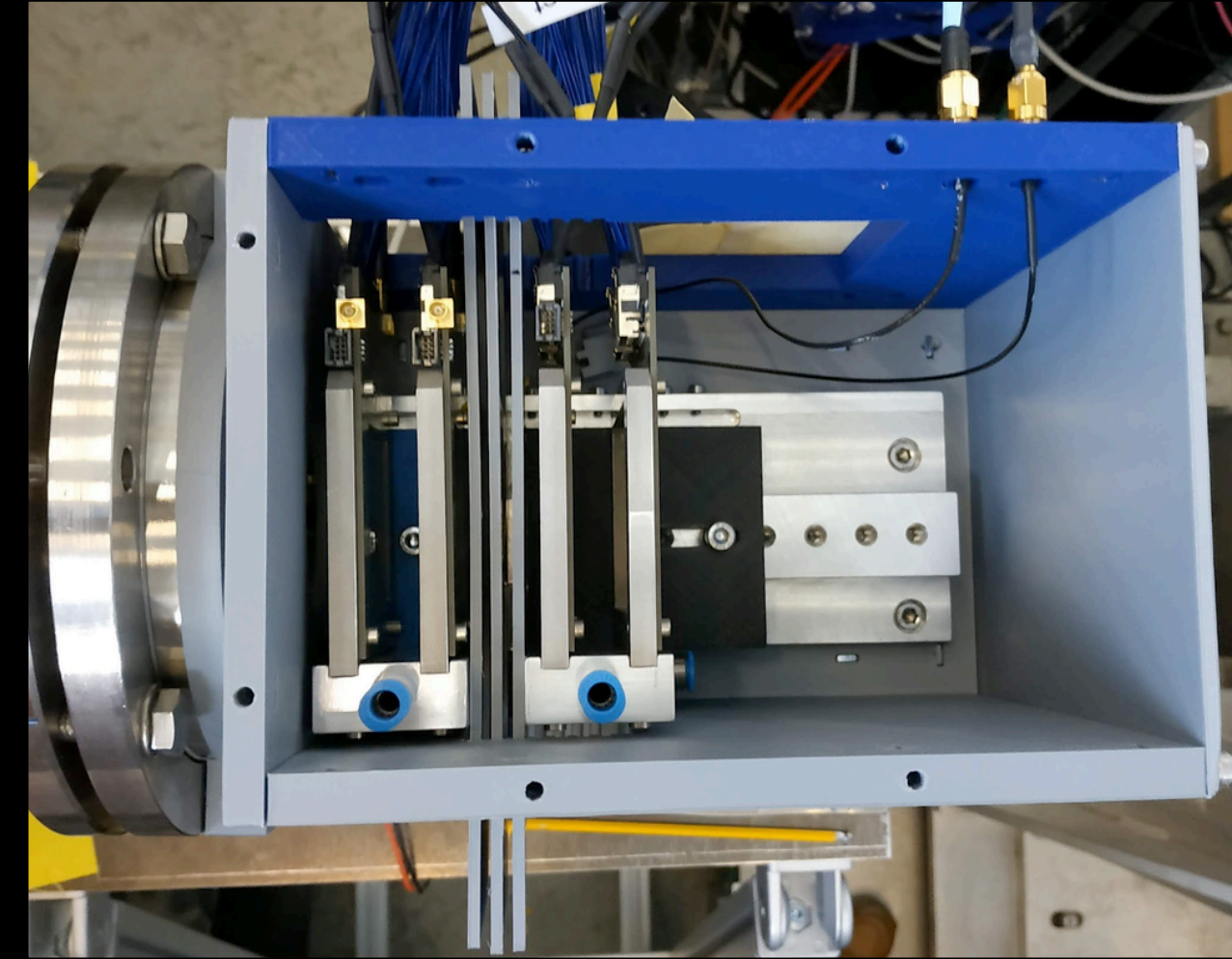
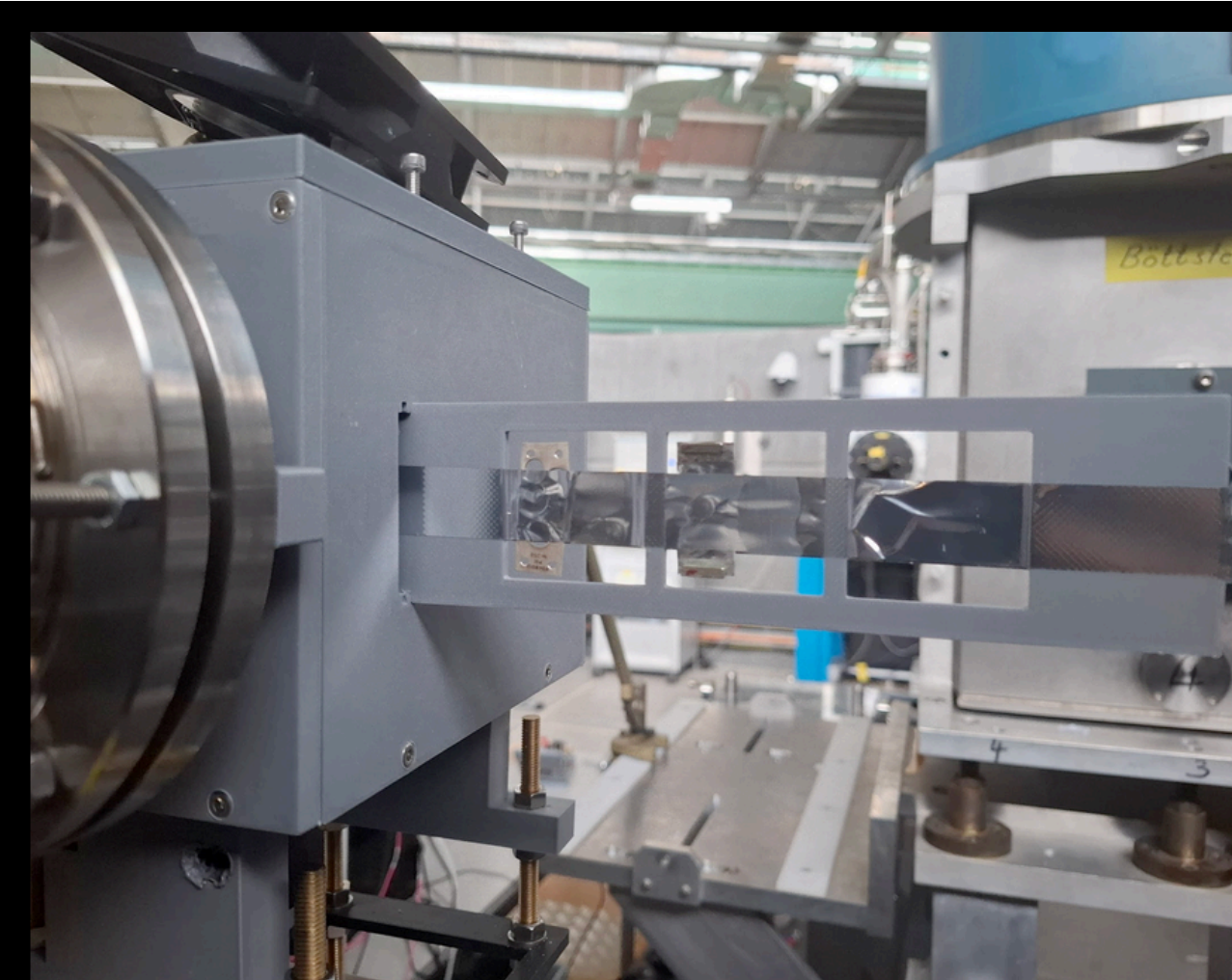
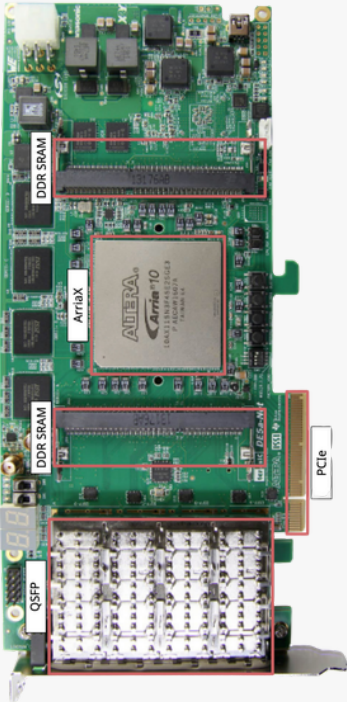

# Setup 08/2025 and 11/2025

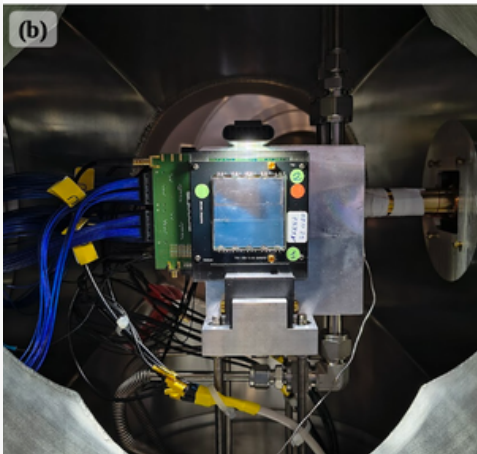
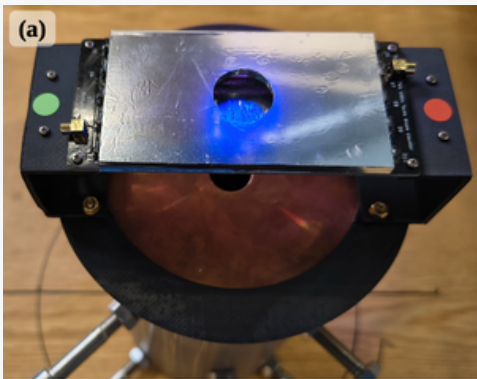
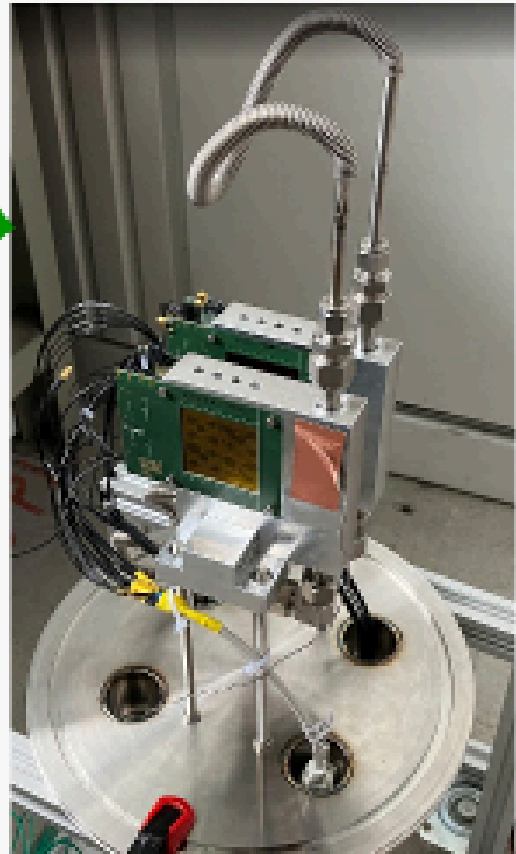
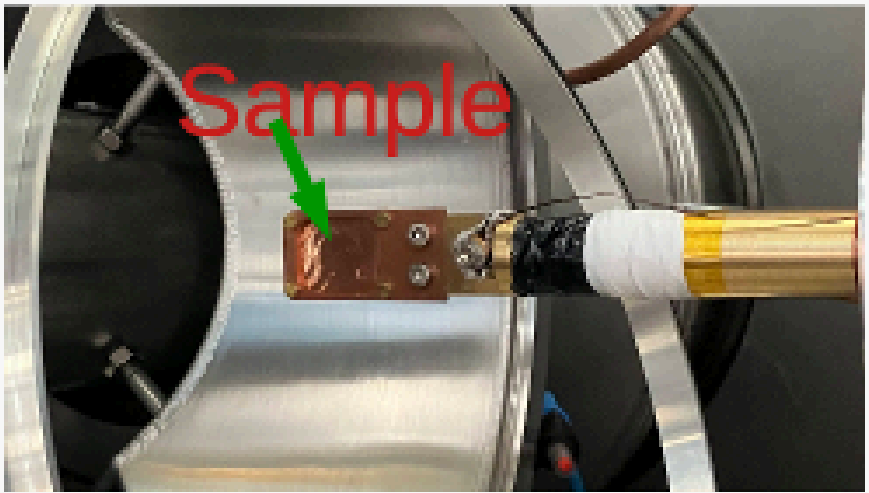
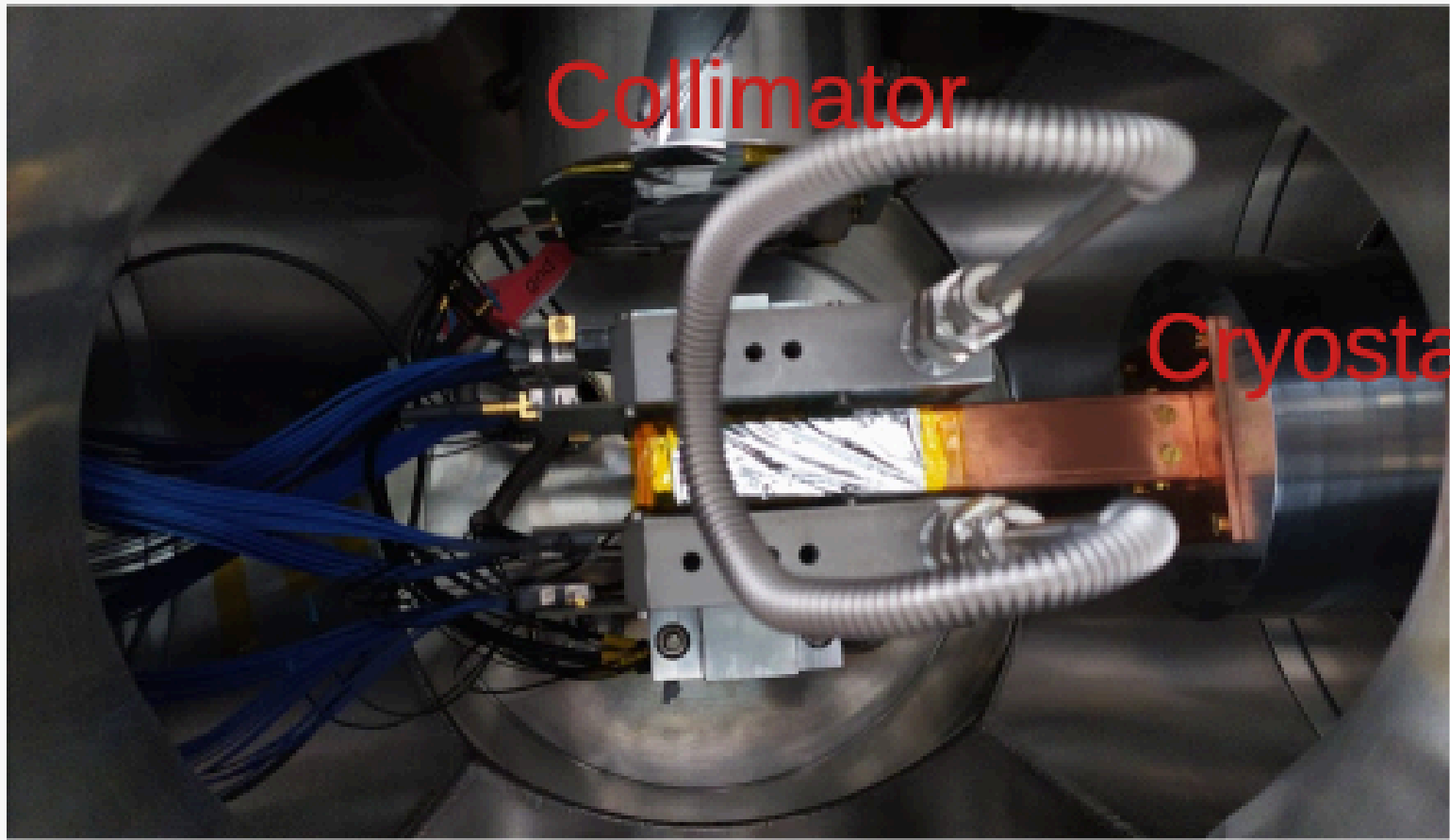
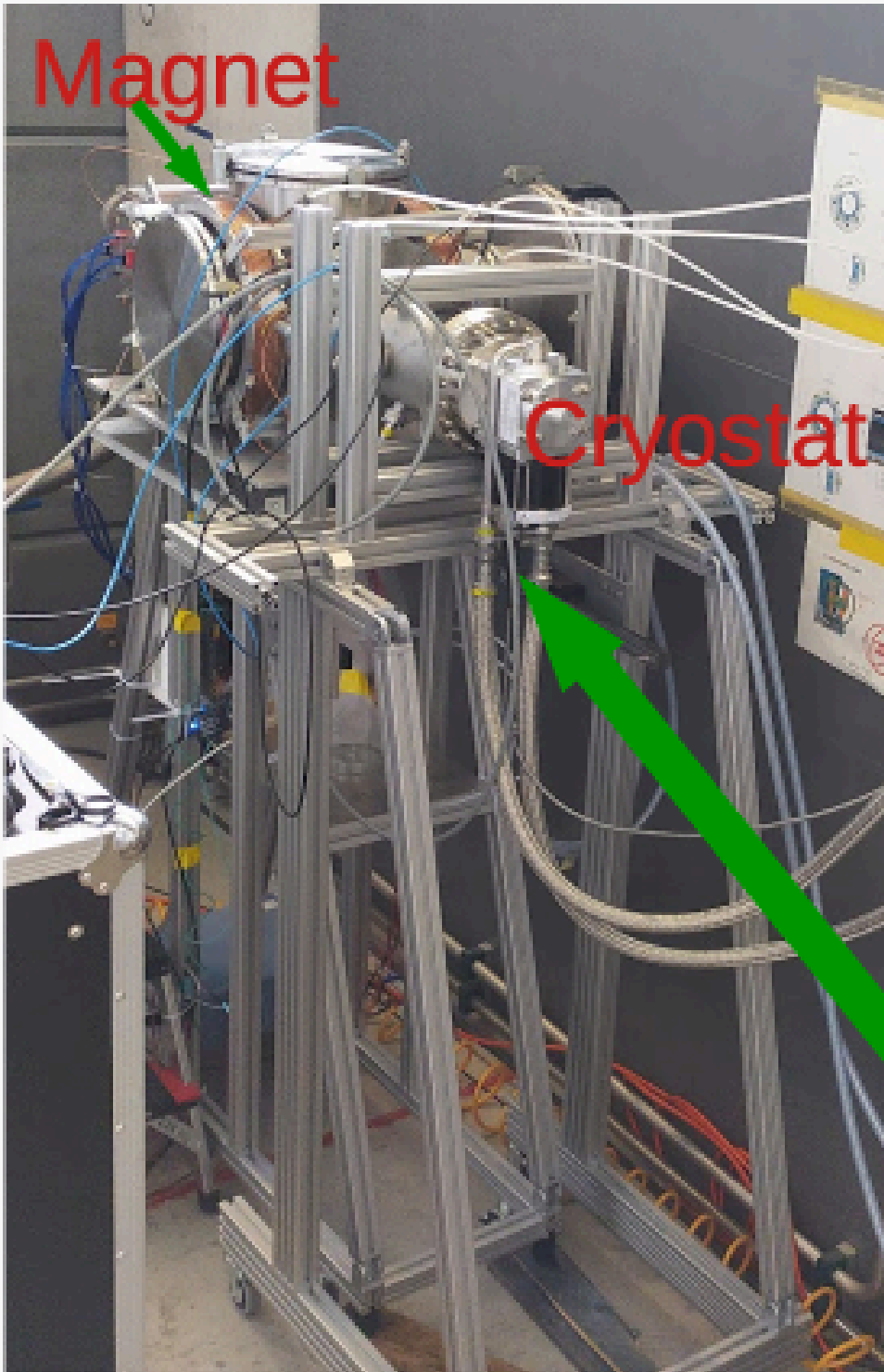

- First MuPix11 operation in vacuum ( $\sim 10^{-7}$  mbar) / water cooling
- First operation near a cryostat
- Plastic Scintillators for timing

# Right now! In "Real-Time"

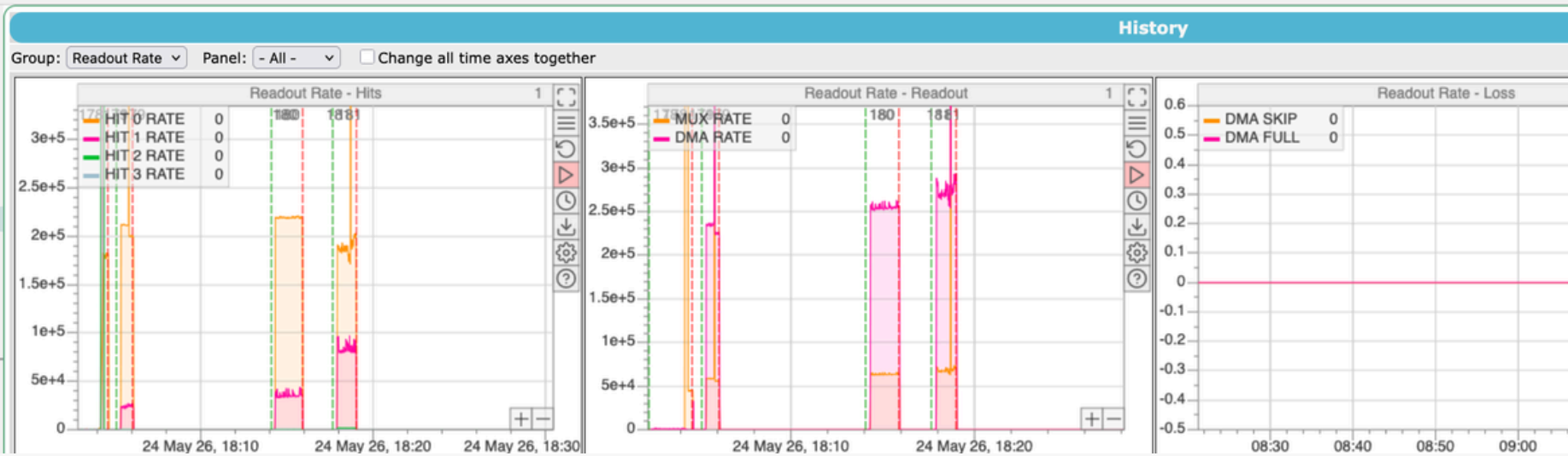

- Musip
- Status
- Transition
- ODB
- Messages
- Elog
- Alarms
- Programs
- Buffers
- History
- MSCB
- Sequencer
- PySequencer
- Event Dump
- Help
- Quads
- DQM
- Mudas
- msetpoint
- msetpoint cfg
- MuTRIG
- LVDS
- HIPA Status
- Documnetation
- Keithley

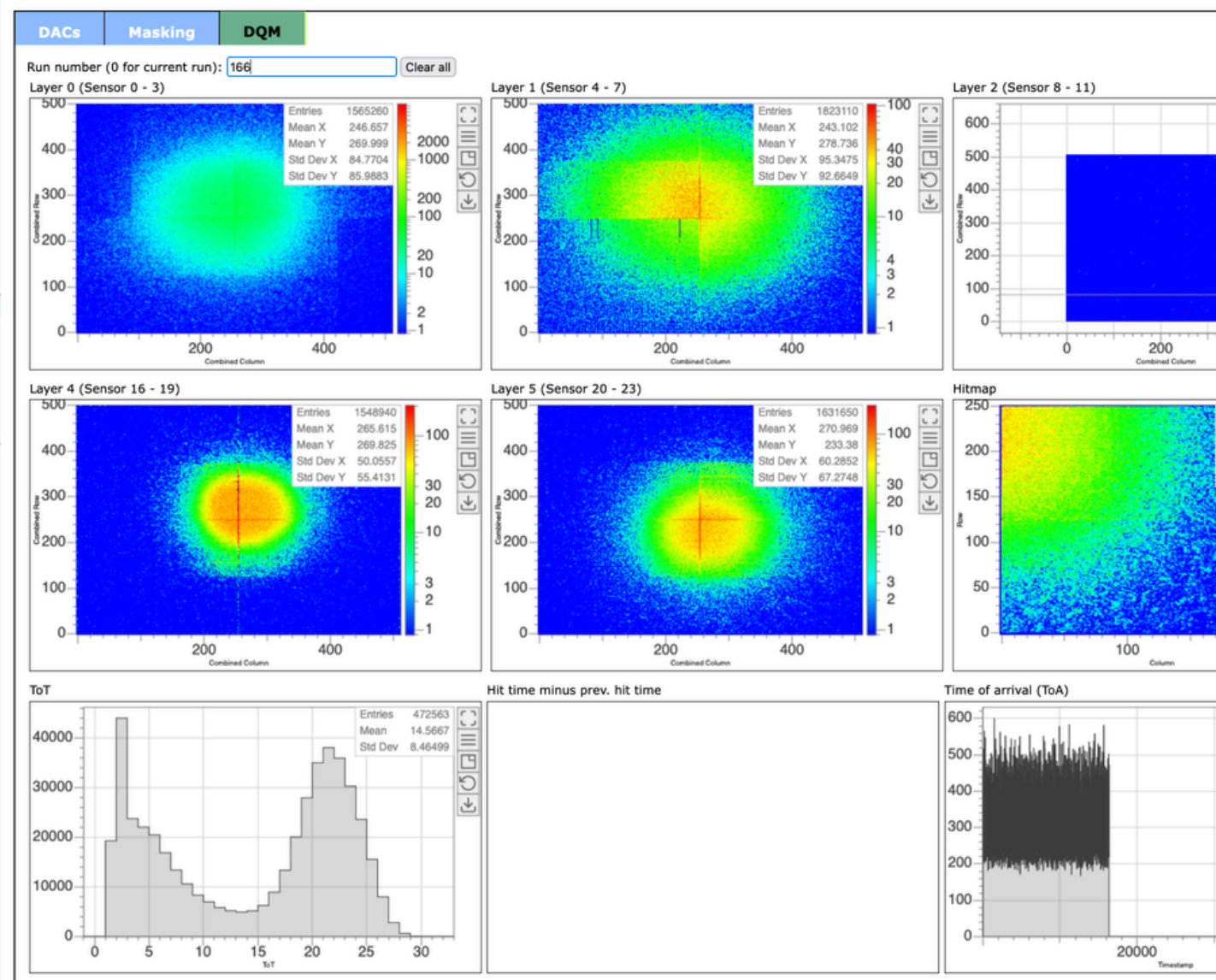

### Run Status

**Run 183**  
Running  
Start: Sun May 24 19:47:43 2026  
Running time: 13h31m16s  
Alarms: On  
Restart: Off  
Data dir: /home/mu3e/musip/online/  
1779693072 09:11:12.163 2026/05/25 [HV Frontend,ERROR] [hvBox\_quads\_fe.cxx:62:fe\_error,ERROR] Error reading MSCB HV4 at "mscb382:2".

### Equipment

Equipment +	Status	Events	Events[/s]	Data[MB/s]
Quads	Quads@localhost	48673	1.0	0.008
LVSUPPLY0	Ok	48397	1.0	0.000
LVSUPPLY1	Ok	48397	1.0	0.000
Quad HV	Ok	812	0.0	0.000
Readout	Readout@localhost	0	0.0	0.000
AnaMusip	Disabled		0.0	0.000
Pump	Ok	3710	0.2	0.000
SCSHV20	Frontend stopped	0	0.0	0.000
Omega	Ok	0	0.0	0.000
LS340	Ok	0	0.0	0.000
K2450	Ok	0	0.0	0.000
compressor	Running	0	0.0	0.000
EPICS	EPICS Frontend@localhost	811	0.0	0.000
Chiller	Running	0	0.0	0.000

### Logging Channels

Channel	Events	MB written	Compr.	Disk Level
#0: run00183.mid.lz4	147894	69.542	18.4%	44.3%
Lazy Label	Progress	File Name	# Files	Total

### Clients

mhttpd [localhost]	Quads [localhost]	HV Frontend [localhost]
ana [localhost]	Readout [localhost]	MOptima [localhost]
Sequencer [localhost]	Omega [localhost]	K2450_SC [localhost]
PySequencer [localhost]	Power Frontend TestBench [localhost]	Sumitomo_Compressor [localhost]
Logger [localhost]	lauda_chiller [localhost]	EPICS Frontend [localhost]
PUMP_SC [localhost]	LS340 SC [localhost]	

# Vertex Resolution 3D $V\mu$ SR "Tomography"

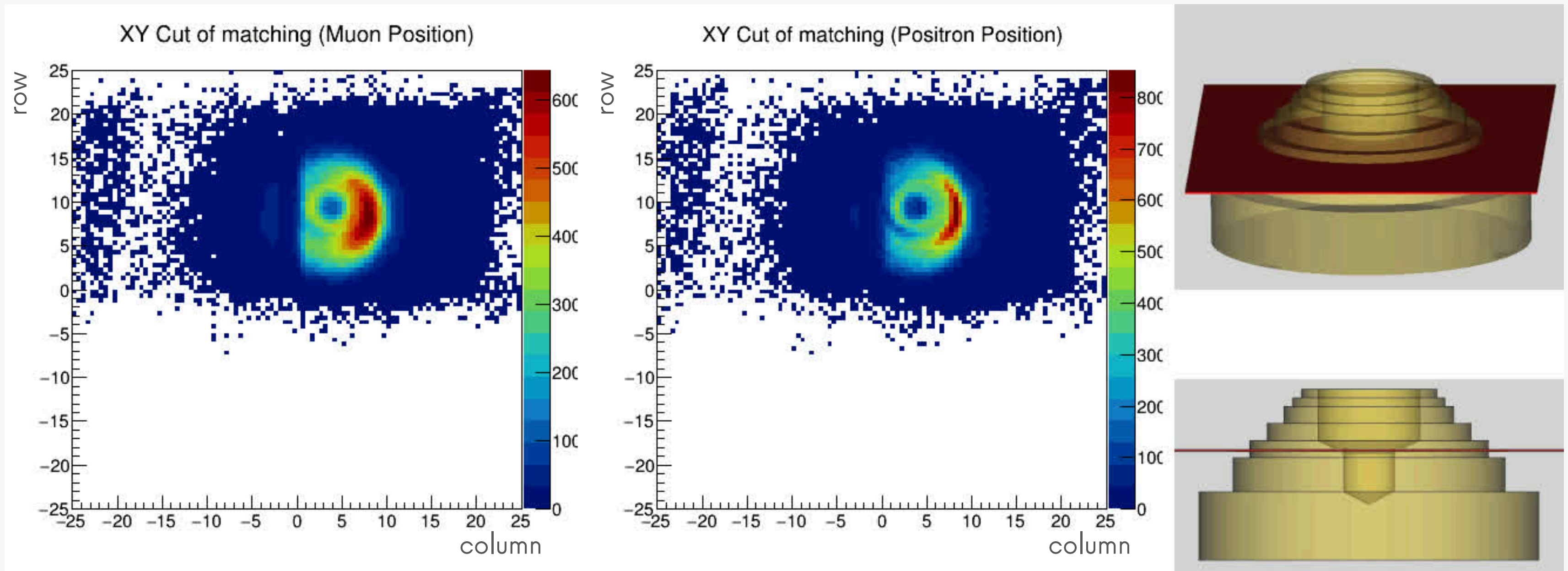

- CNC processed 3d object
- Move z-position during analysis
- Intersection incoming muons and positron trajectories
- Lateral vertex resolution  $\leq 1$  mm

# Vertex Resolution 3D $V\mu$ SR "Tomography"

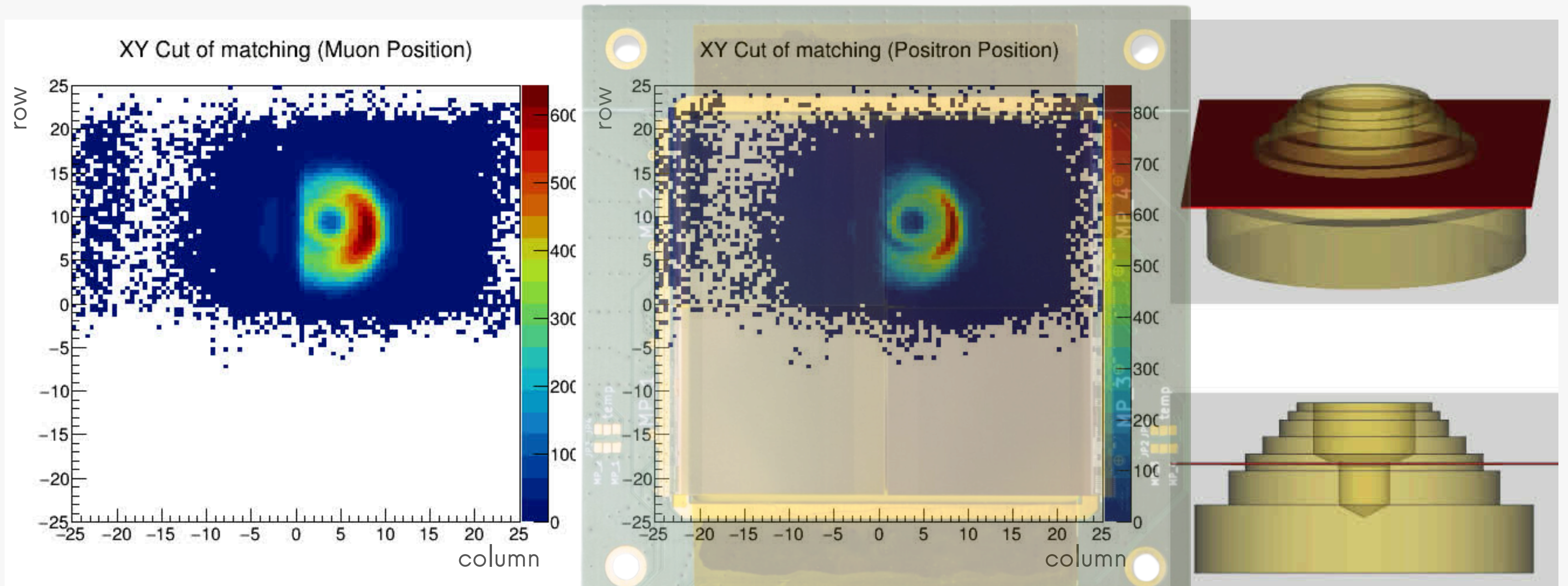

- **CNC** processed **3d object**
- **Move z-position** during analysis
- **Intersection** incoming **muons** and **positron** trajectories
- Lateral vertex resolution  $\leq 1$  mm

# Vertex Resolution

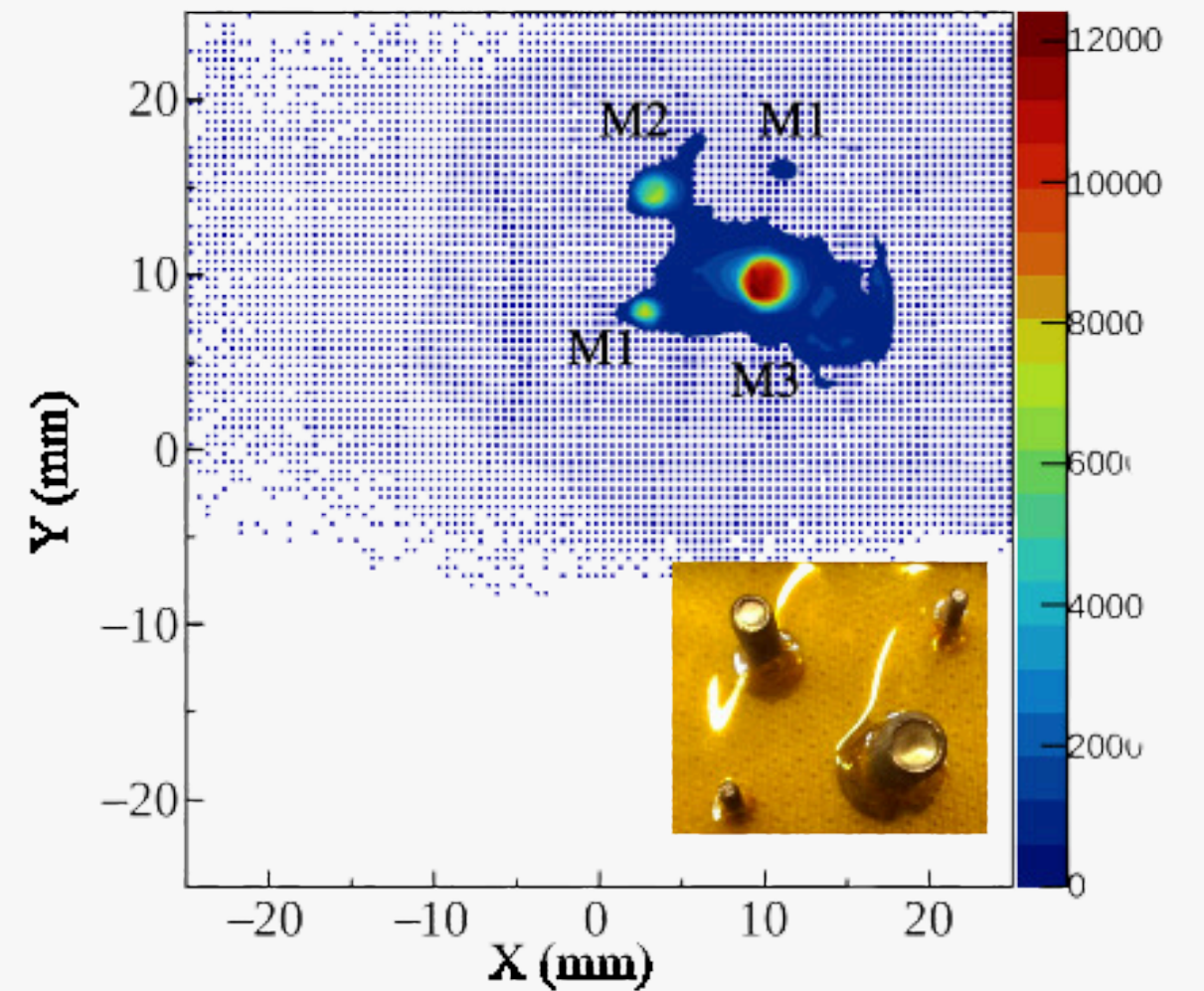
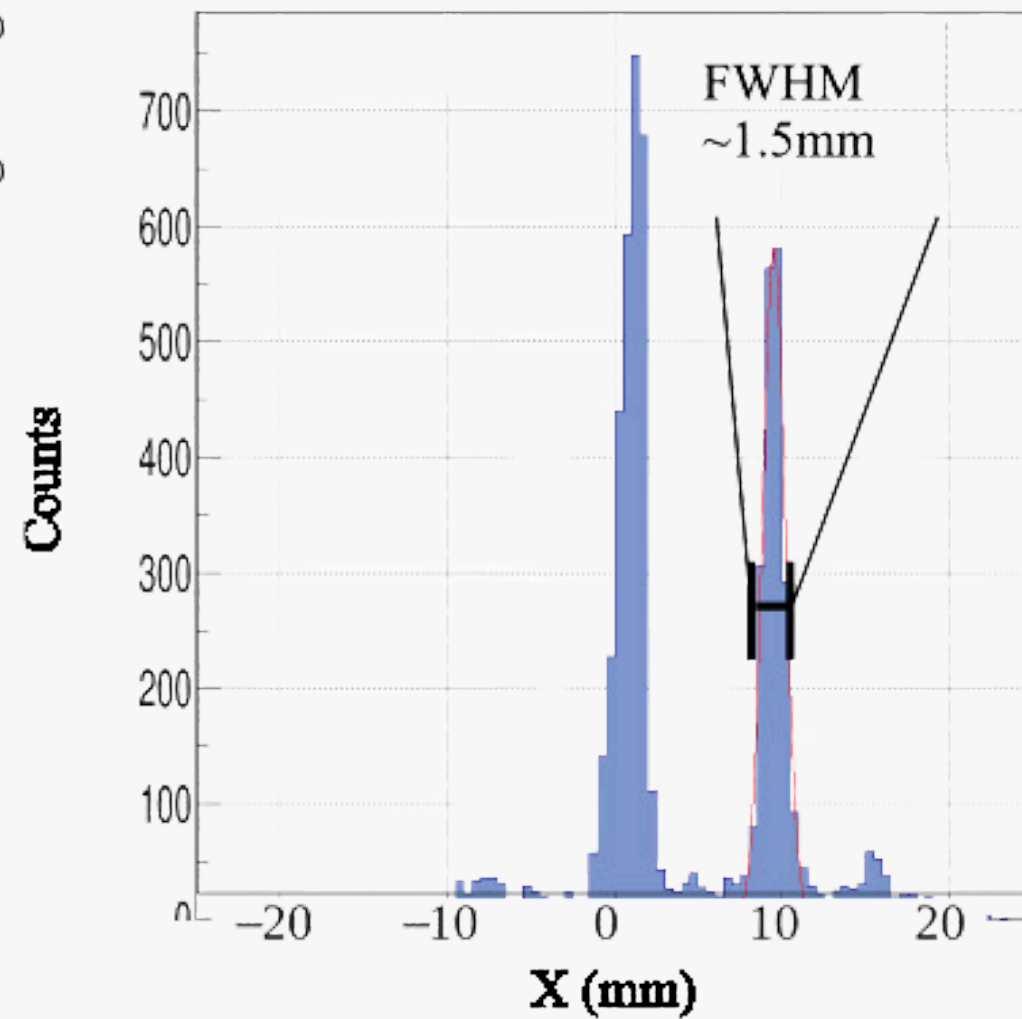
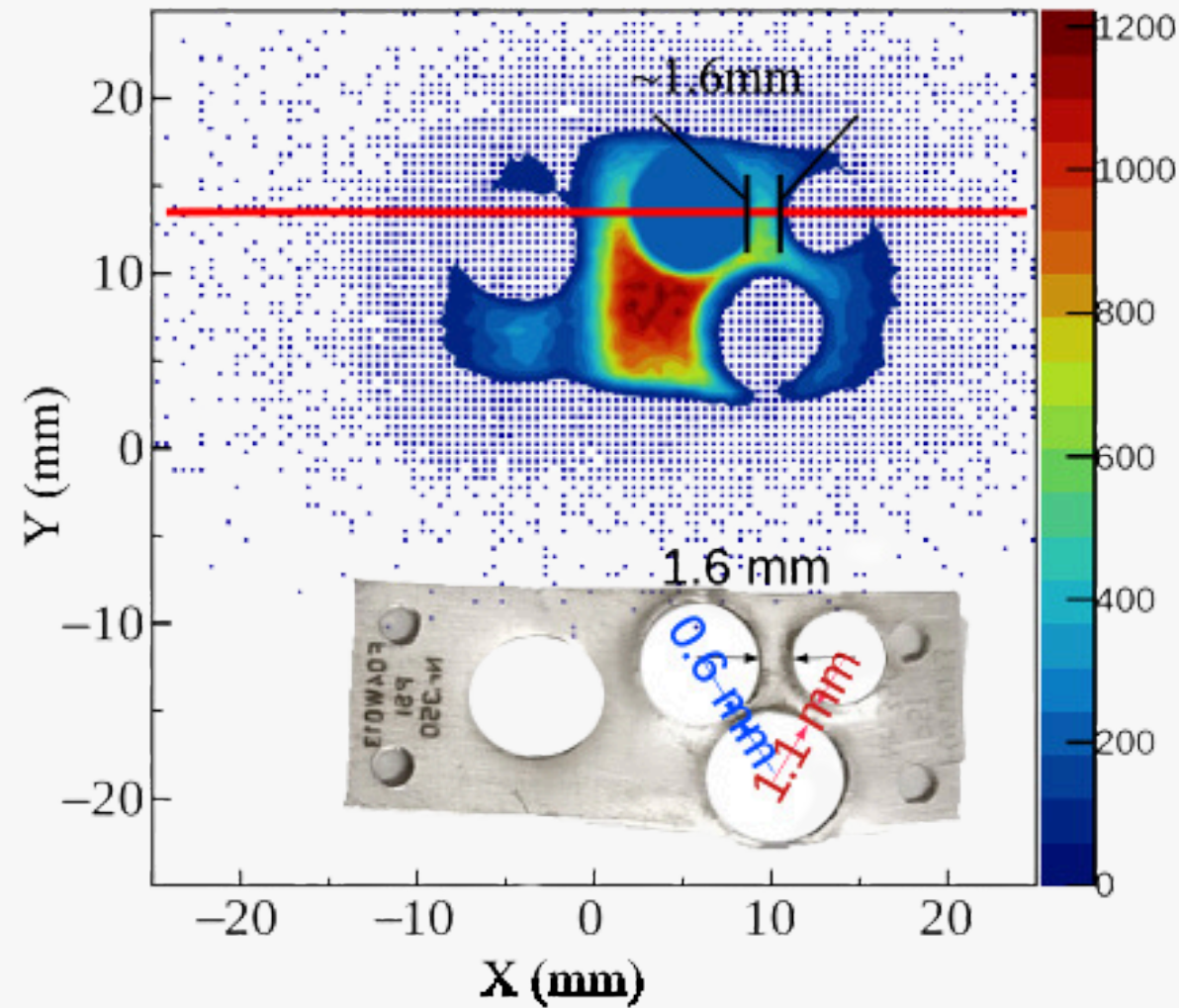

- **Combination** of multiple runs
- **Measurement** of different objects
- **Intersection** incoming **muons** and **positron** trajectories
- Lateral vertex resolution  $\leq 1$  mm

# Spin Rotation

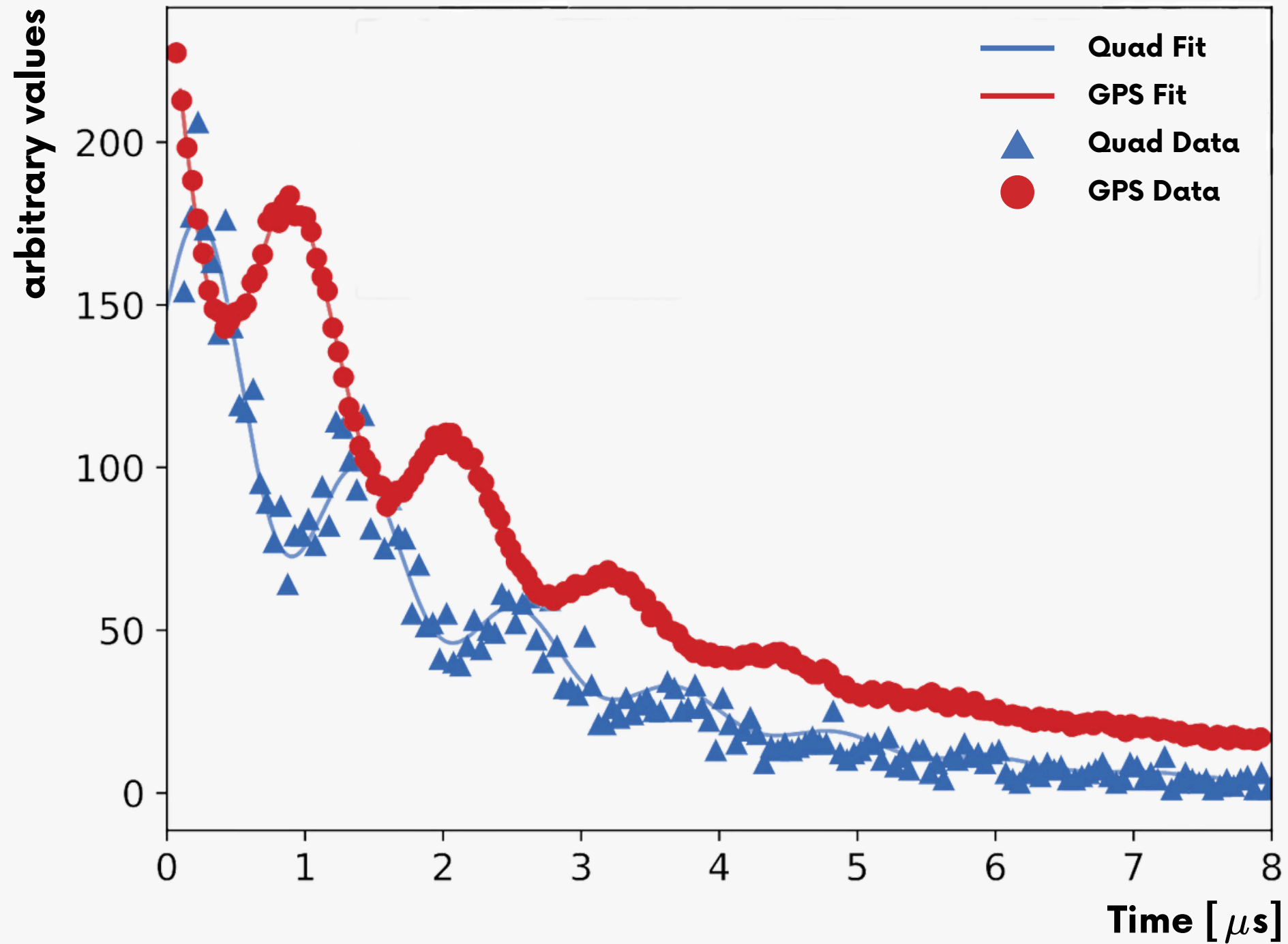

## Sample

- Aluminum disk
- $\varnothing = 6 \text{ mm}$
- $B = 6.3 \text{ mT}$

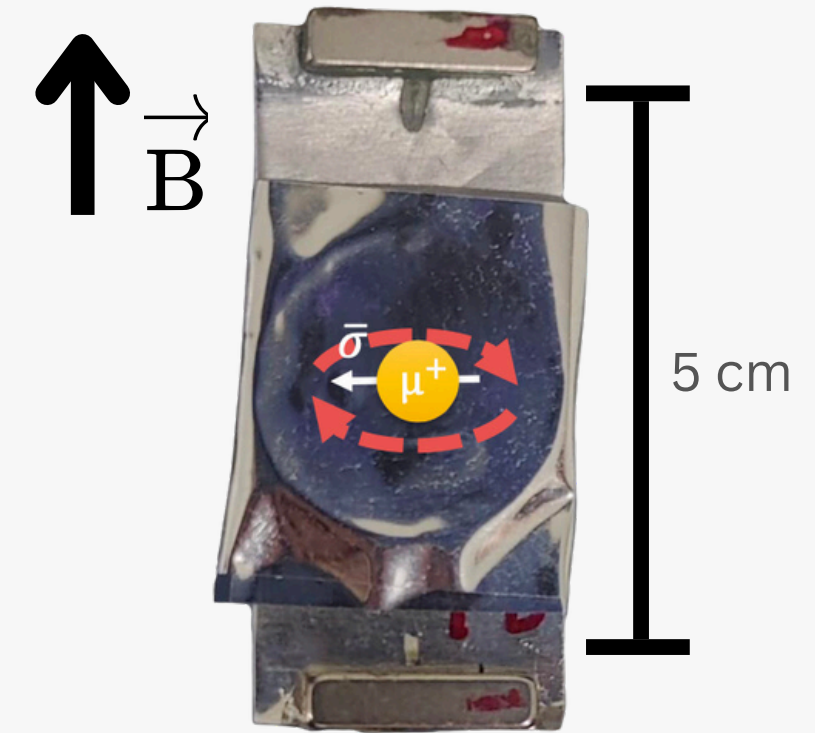

## Results

- Low statistics (3s)
- Same precession frequency  
 $0.868 \pm 0.057 \text{ MHz}$  (Quad)  
 $0.857 \pm 0.002 \text{ MHz}$  (GPS)
- Negligible background

# Field Map

**NOTE: Z scale is the same**

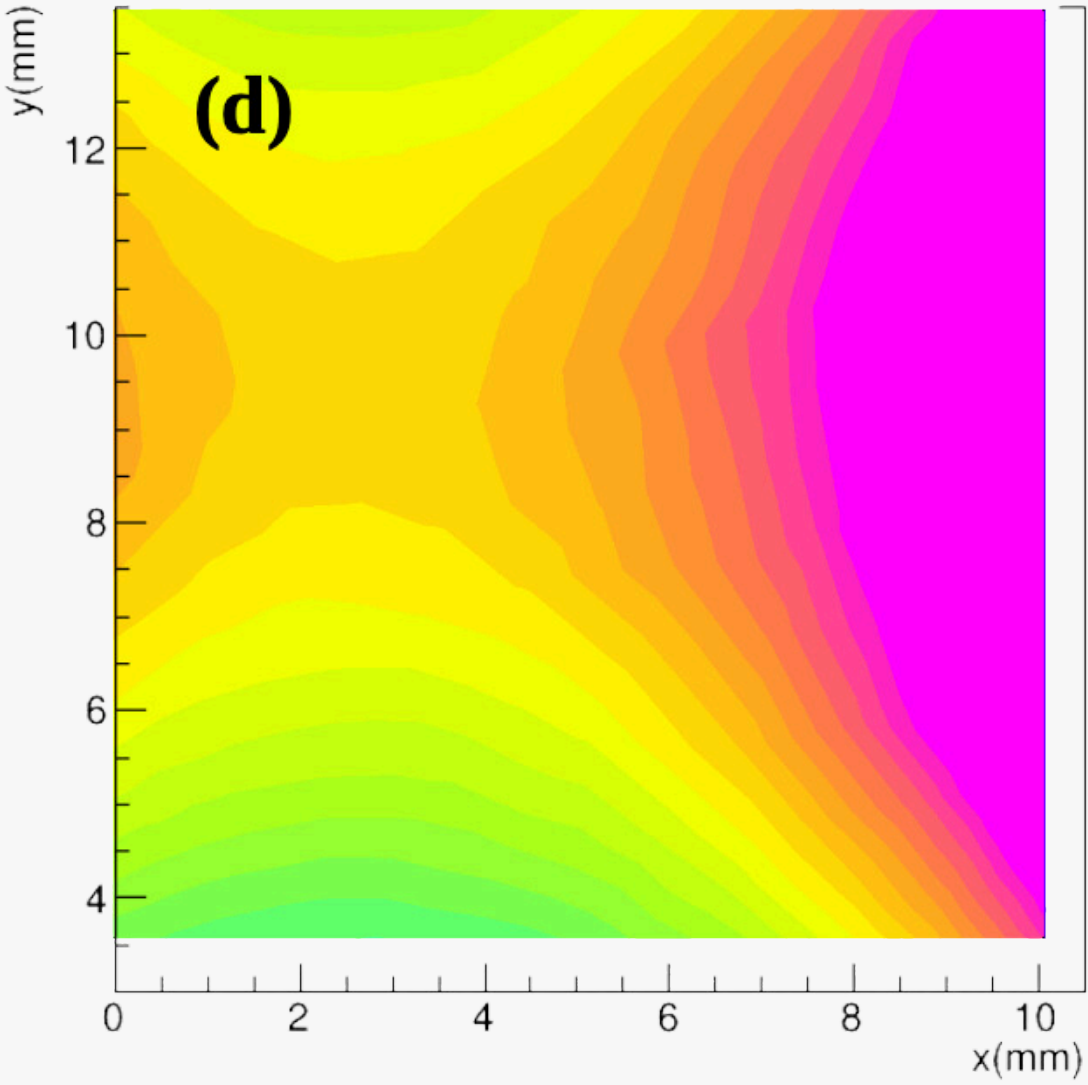
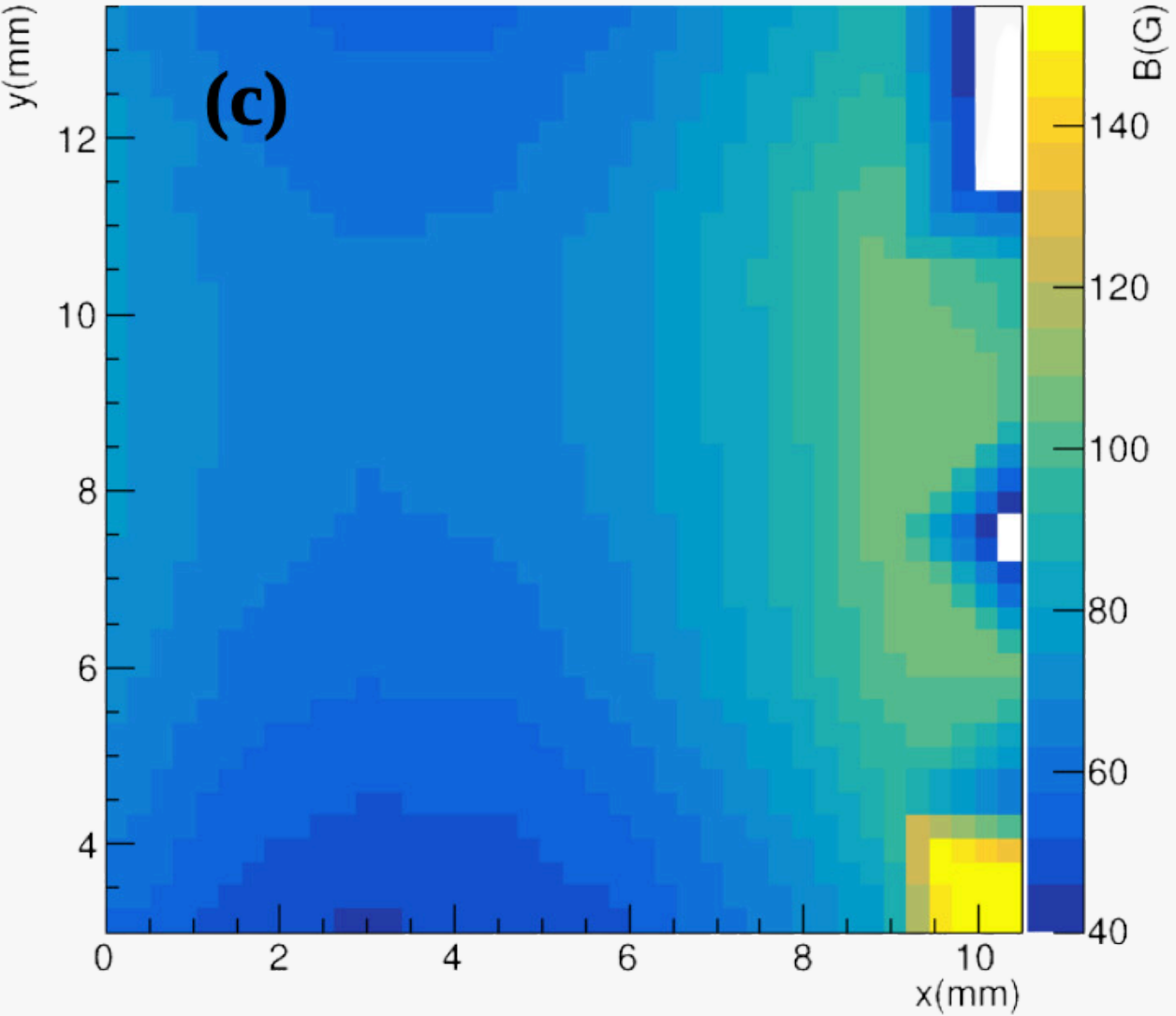
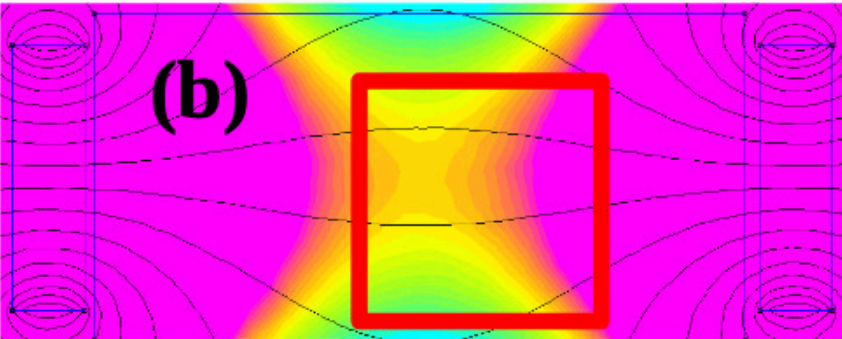

- a) Silver plate with permanent magnet
- b) Simulation of the magnetic field

- c) Measurement of magnetic field
- d) Zoomed in simulation

# Wrap-Up

- **MuSR**

- Material Science Technique
- Measurement of novel battery and quantum materials
- Challenges are good vertex and high muon rates

- **Quad and DAQ**

- Development of first Si-Pixel based MuSR detector
- Fully triggerless system was designed and implemented
- Analysis of test runs

More tests in magnetic field are happening right now!

# **THANK YOU!**

PEOPLE INVOLVED IN THE PROJECT:

HEIKO CHRISTIAN AUGUSTIN, NIKLAUS EMANUEL BERGER, ANDRIN DOLL,  
PASCAL ISENRING, JONAS ANDREAS KRIEGER, MARIUS KÖPPEL, HUBERTUS  
LUETKENS, LUKAS MANDOK, THOMAS PROKSCHA, THOMAS RUDZKI, ZAHER  
SALMAN, ANDRE SCHOENING