

25th IEEE Real Time Conference
May 25 – 29, 2026 – La Biodola

THE BESIII CYLINDRICAL GEM INNER TRACKER DATA ACQUISITION SYSTEM

**How is that a prototype tool, developed for detector testing and validation,
successfully became the official CGEM DAQ system**

G. CIBINETTO (INFN FERRARA)
on behalf of the CGEM-IT group

The **BESIII** experiment @ BEPCII

- e^+e^- collider located at the Institute of High Energy Physics in Beijing (PRC)
- Center-of-mass energy spanning the τ -charm sector ($2 - 4.95 \text{ GeV}$)
- $\mathcal{L}_{peak} = 1.0 \times 10^{33} \text{ cm}^{-2}\text{s}^{-1}$
- World's largest sample of
 - $J/\psi \rightarrow 10$ billions
 - $\psi(2S) \rightarrow 3$ billions
 - $\psi(3770) \rightarrow 20 \text{ fb}^{-1}$
- About 22 fb^{-1} of data for Exotic Charmonium Spectroscopy

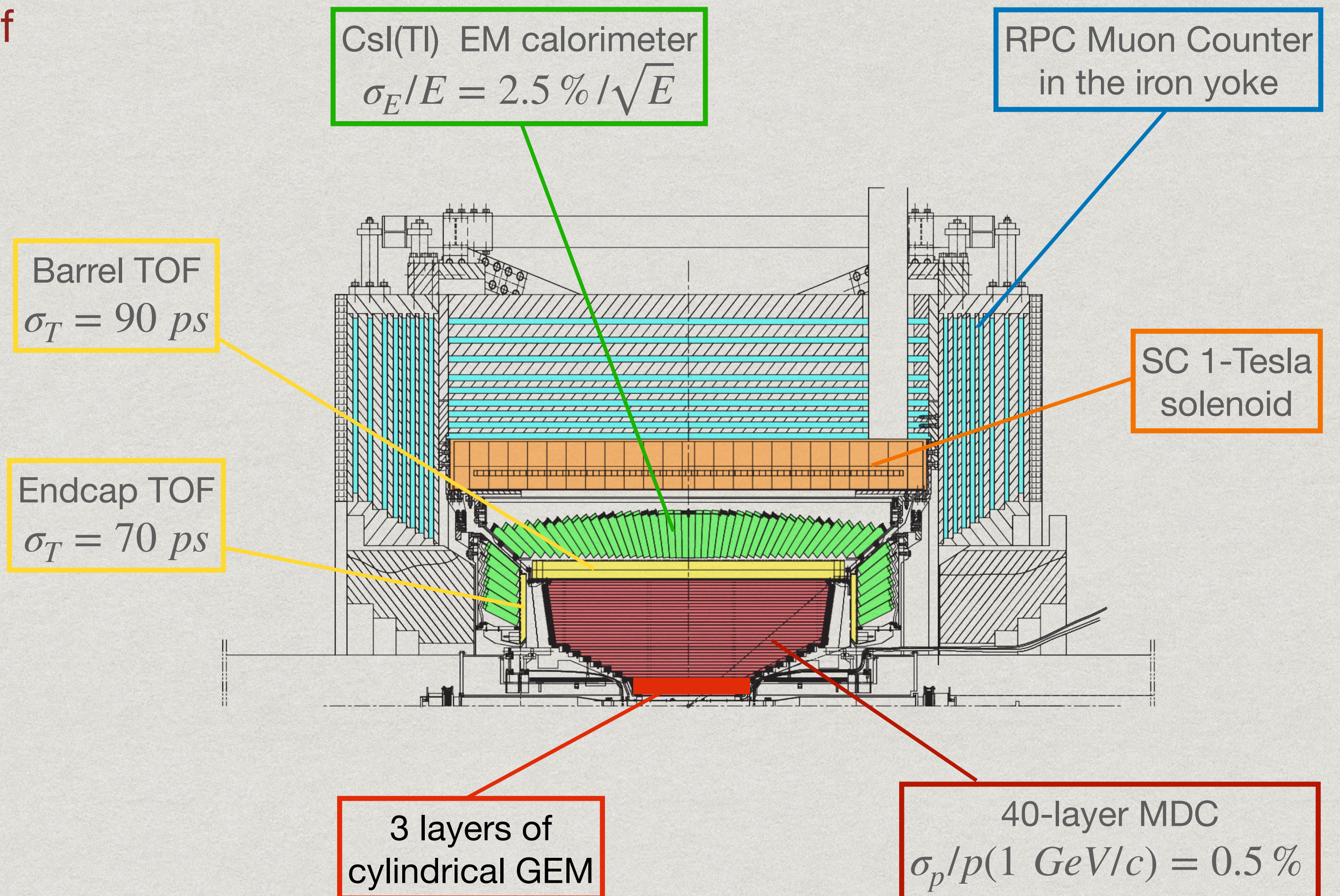

The Inner Tracker upgrade: with Cylindrical GEM

- * 3 layers of cylindrical triple-GEM detectors (about 10k channels with time and charge readout)
- * Improve rate capability, aging and secondary vertex reconstruction
- * While retaining the current momentum and tracking performance ($\sigma_p/p \sim 0.5\%$ @ 1 GeV)
- * Main System Requirements
 - * Angular coverage: 93%
 - * Low material budget ($\sim 0.5\%$ of X_0 per layer \rightarrow 1.5% of X_0 in total)
 - * High azimuthal spatial resolution \rightarrow 130-150 μm with charge and time readout
 - * Substantial improvements in **rad hard** and **secondary vertex** reconstruction ($\sim 300\ \mu\text{m}$ in z)

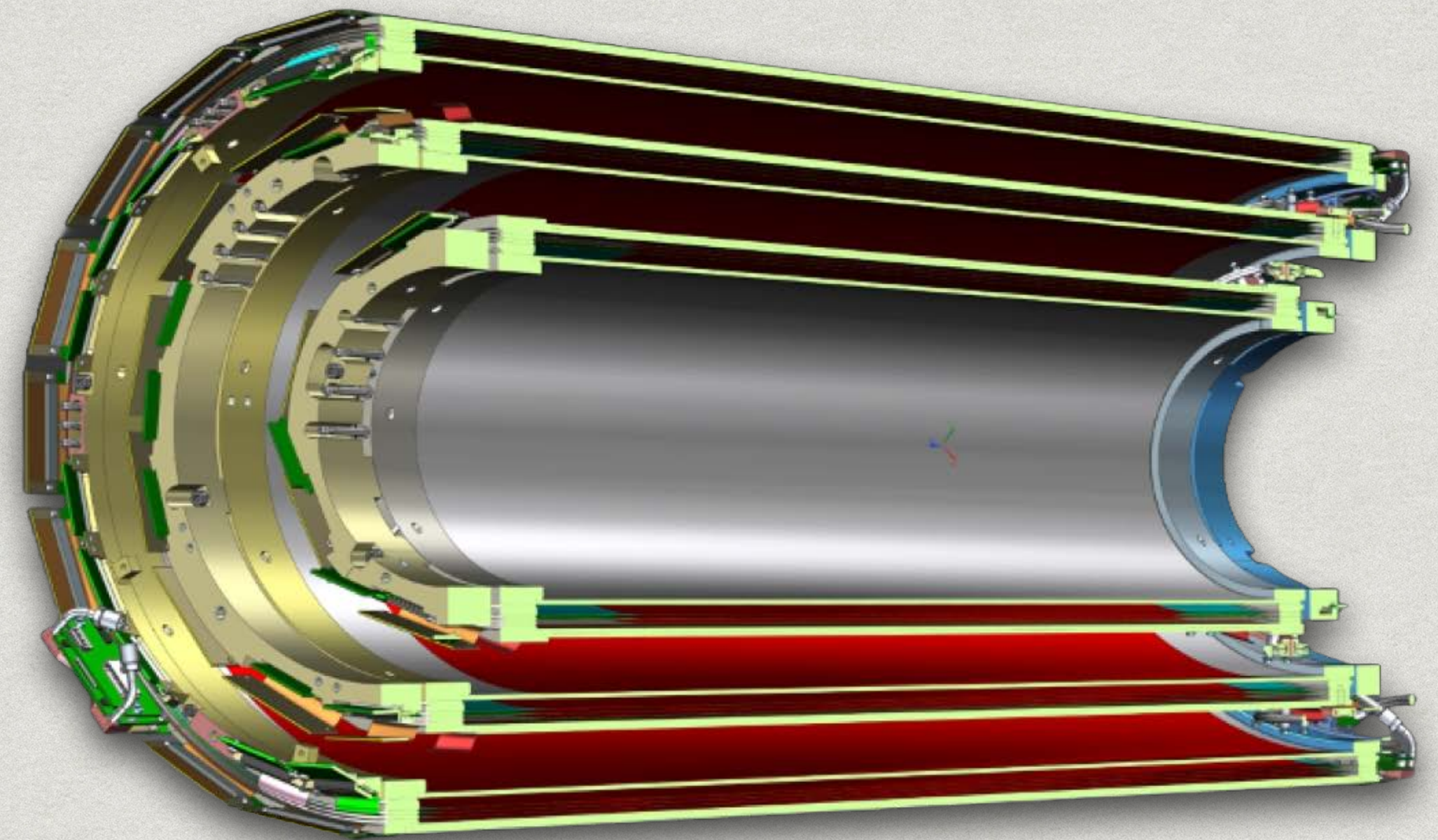

The BESIII upgrade program

- * BEPCII upgrade increased the luminosity by a factor of 3 & increasing beam energy to 2.8 GeV
- * Key technologies: double beam power & optics upgrade & new high gradient of magnets

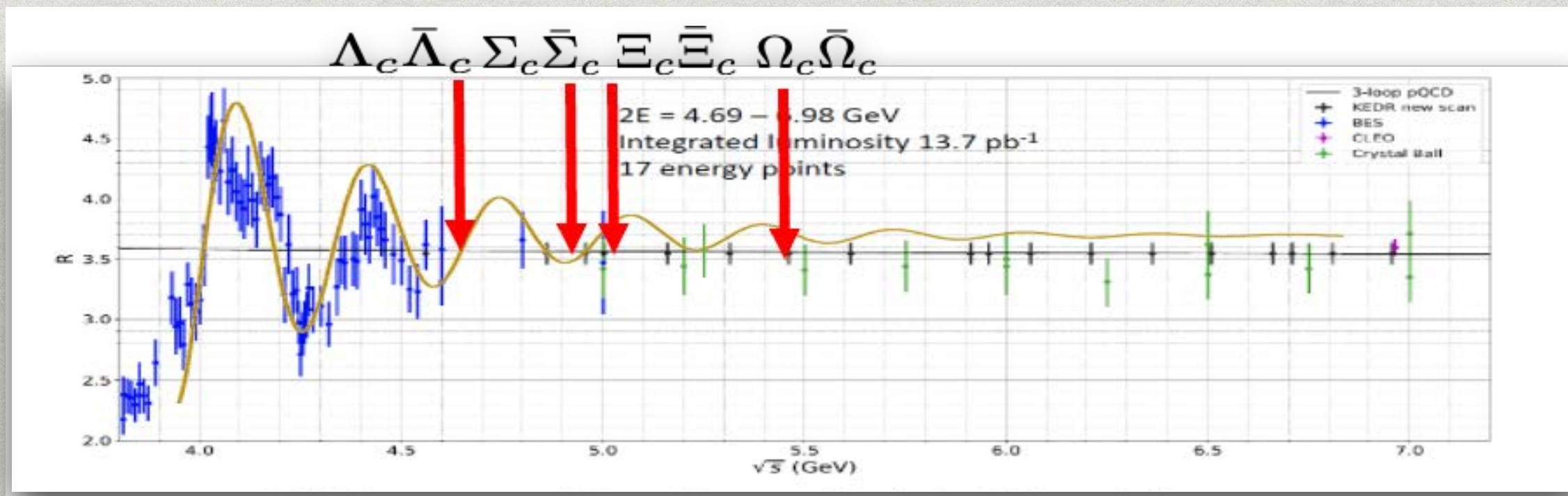
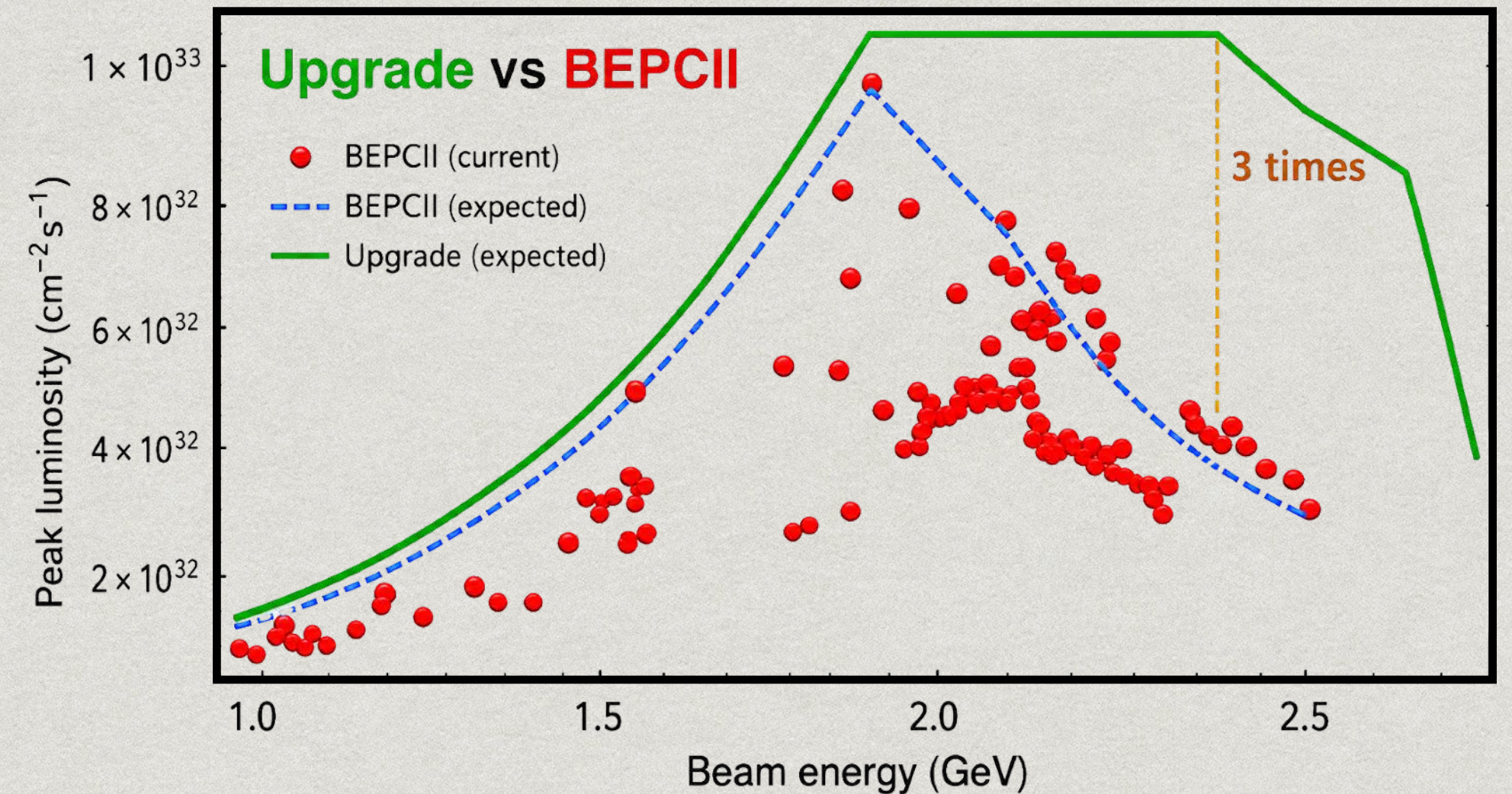

- * Unlock opening of new production thresholds
- * Secondary vertex resolution very important for Charmed Baryon studies

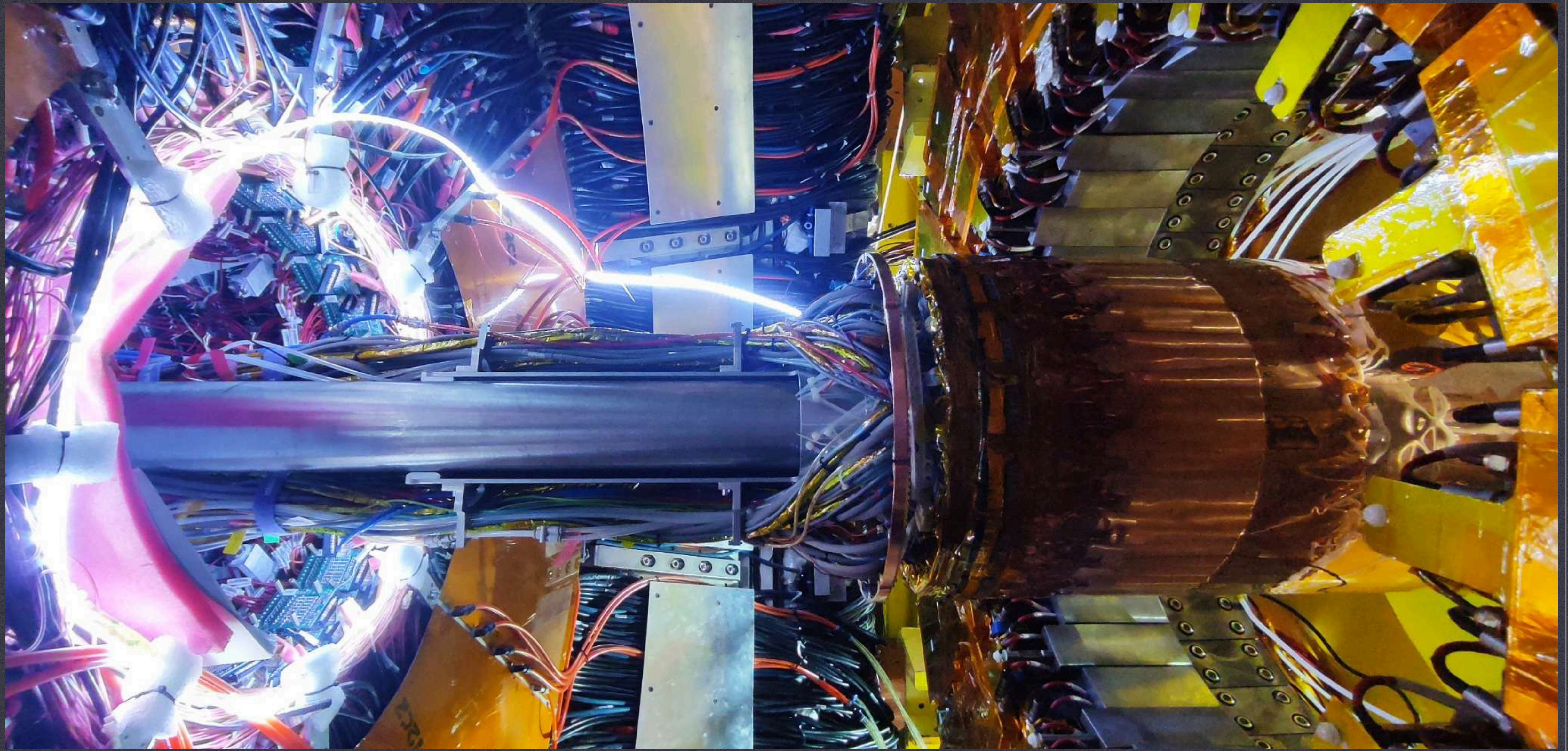

THE CGEM-IT DURING THE 2024 INSTALLATION

TIGER ASIC: the digital brain of the front-end electronics

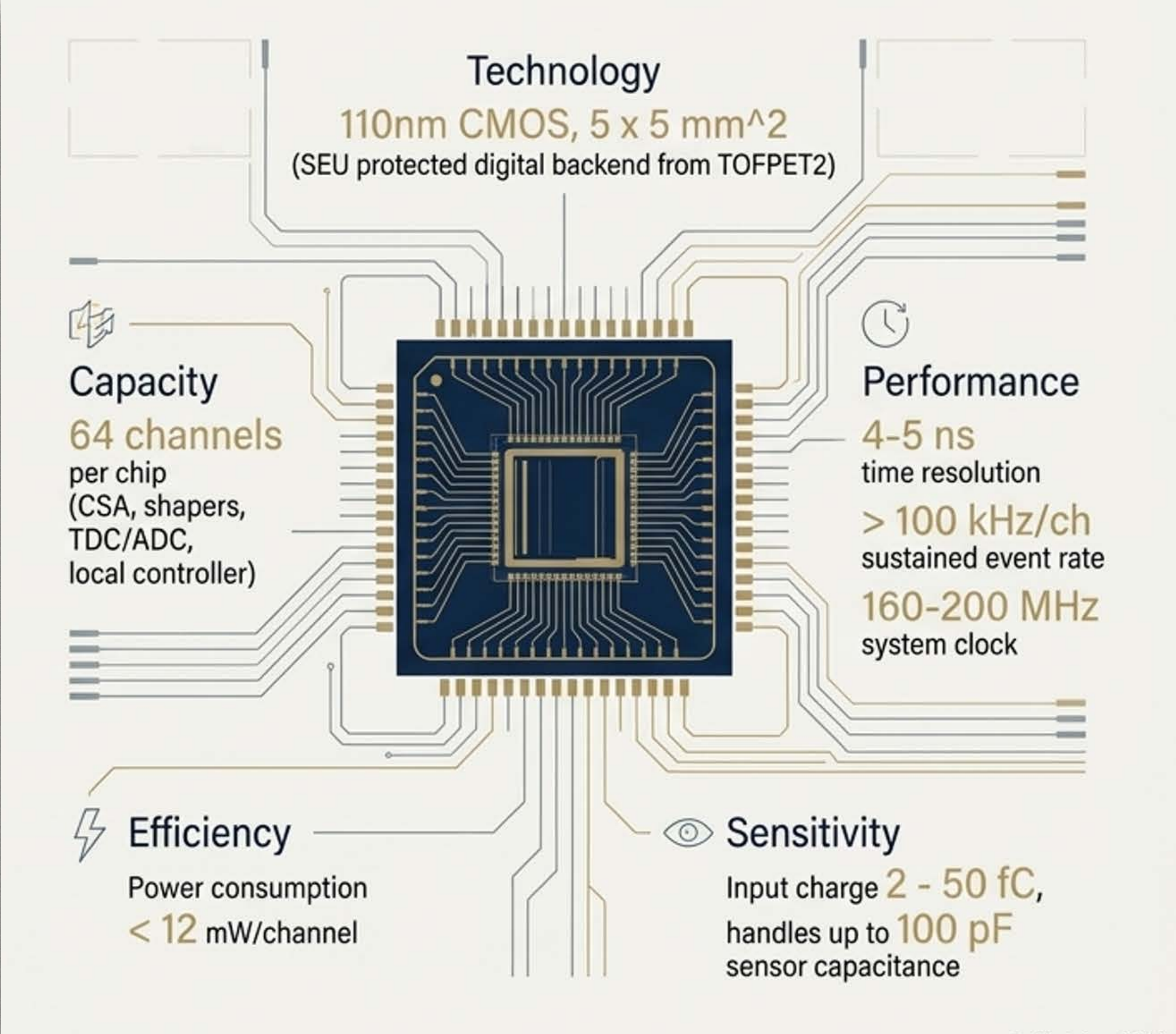

- * Trigger-less operation, fully digital output
- * Independent T and E branches for time and energy measurements

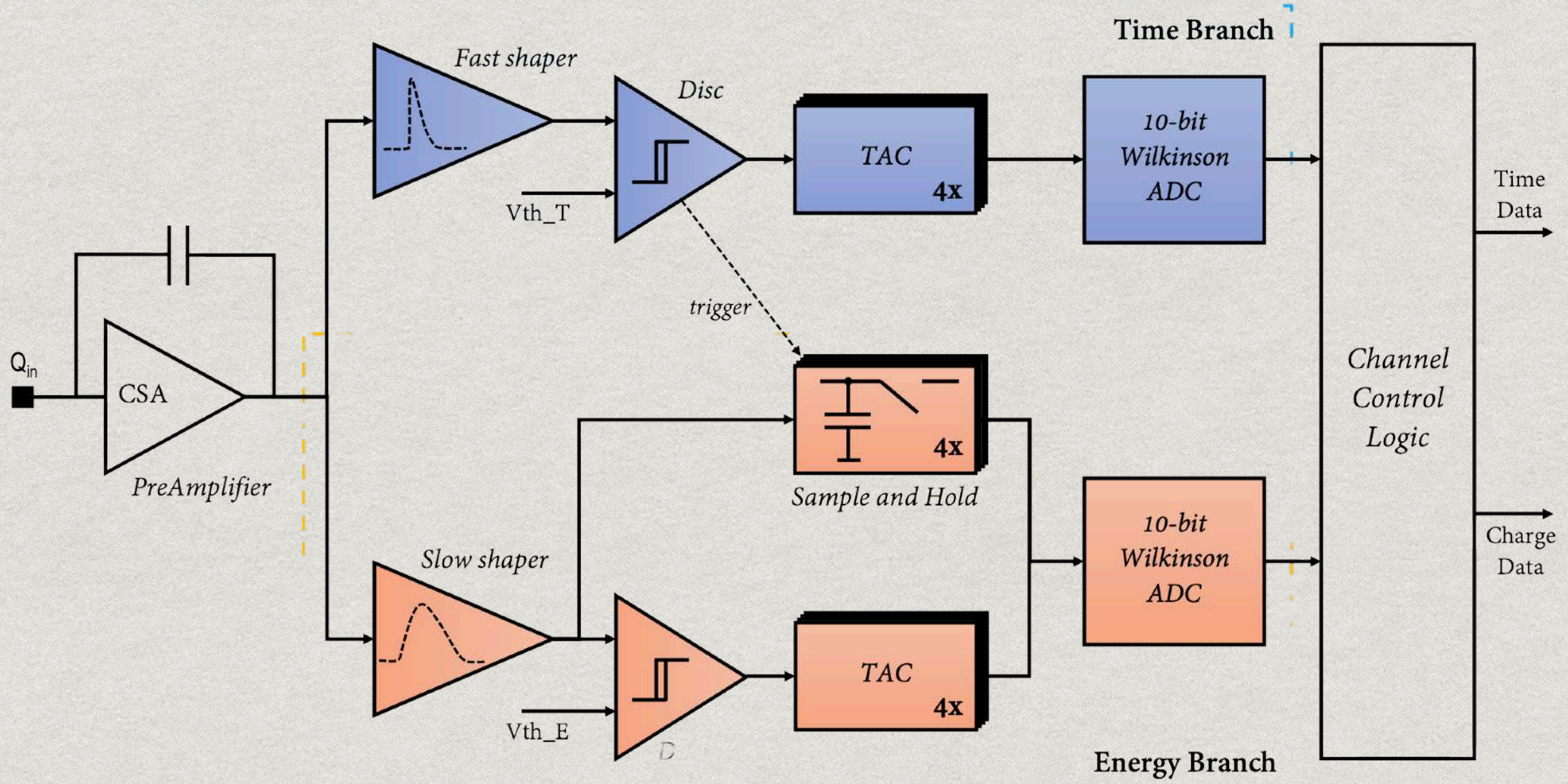

GEMROC: the off-detector traffic controller

	<p>Power & Monitor</p> <p>Supplies power to the 80 FEBs while actively monitoring chip voltages and temperatures.</p>
	<p>Timing & Config</p> <p>Configures the ASICs and receives master timing signals.</p>
	<p>Bridging</p> <p>Controls data acquisition and translates LVDS input into optical links and Ethernet for the DAQ.</p>
	<p>Scale</p> <p>22 modules</p>

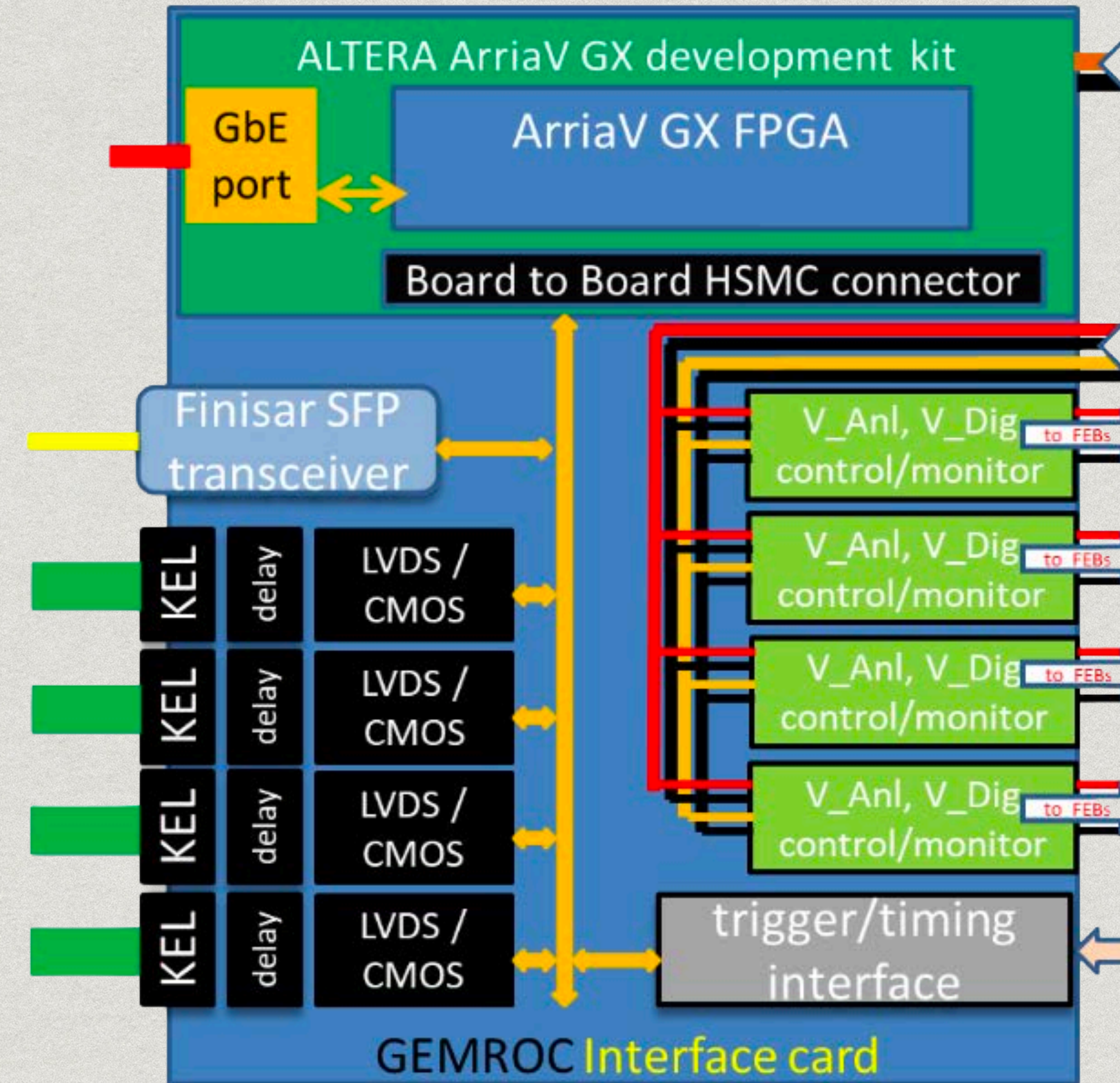

GEMROC: the off-detector traffic controller

	<p>Power & Monitor</p> <p>Supplies power to the 80 FEBs while actively monitoring chip voltages and temperatures.</p>
	<p>Timing & Config</p> <p>Configures the ASICs and receives master timing signals.</p>
	<p>Bridging</p> <p>Controls data acquisition and translates LVDS input into optical links and Ethernet for the DAQ.</p>
	<p>Scale</p> <p>22 modules</p>

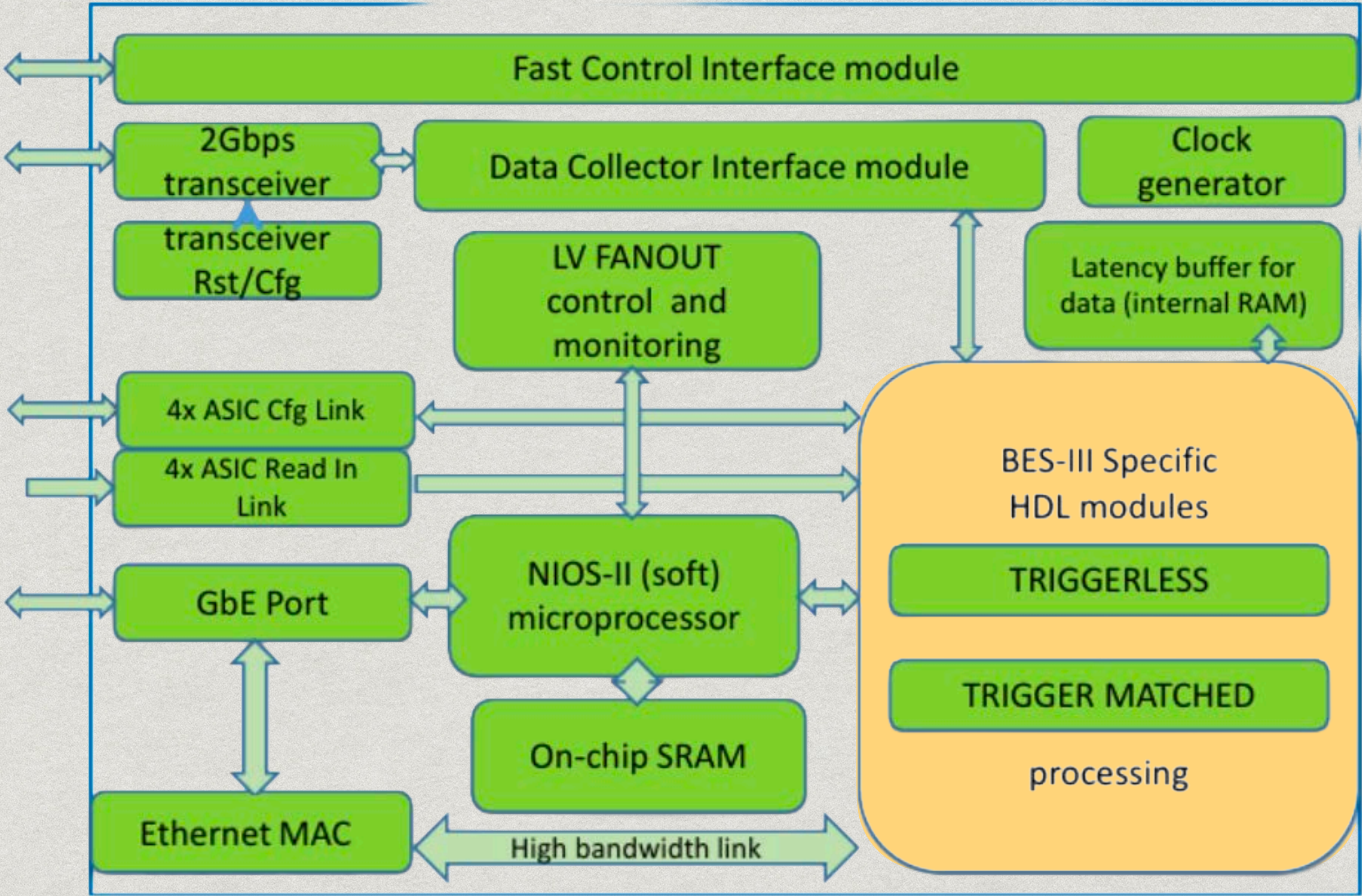

Trigger matched with circular buffer for physics data taking
Triggerless for calibration, debugging and special running modes

The BESIII DAQ system

- * Key Parameters of the BESIII DAQ system

- * ~39 VME readout crates (~30k channels)

- * L1 trigger rate: 4 kHz

- * Average event size: ~14 kB

- * DAQ readout bandwidth: 80 MB/s

- * 42 IBM eServerBlade nodes

- * L3/Event filter \rightarrow <1 kHz

- * ATLAS TDAQ-based software

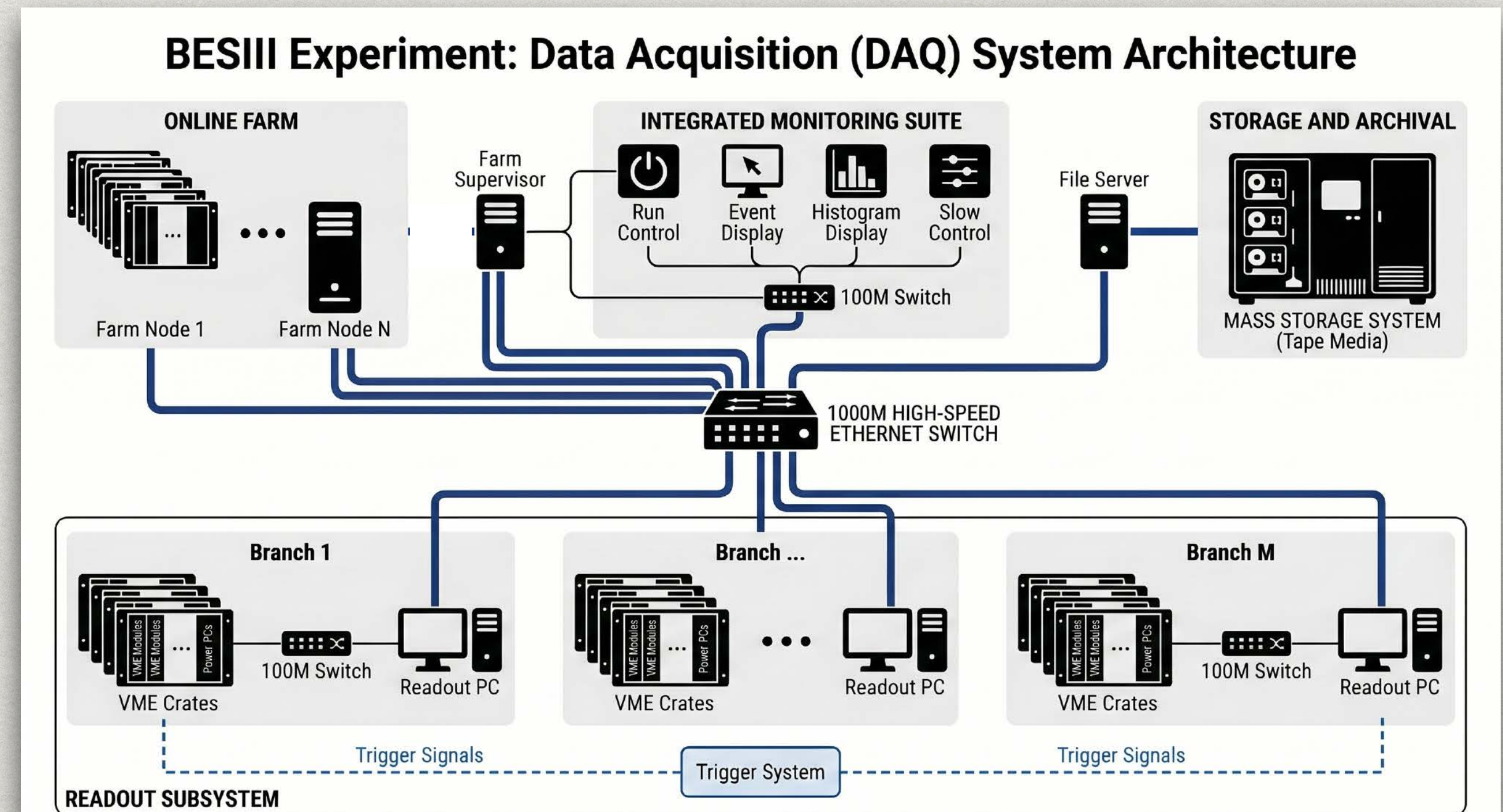
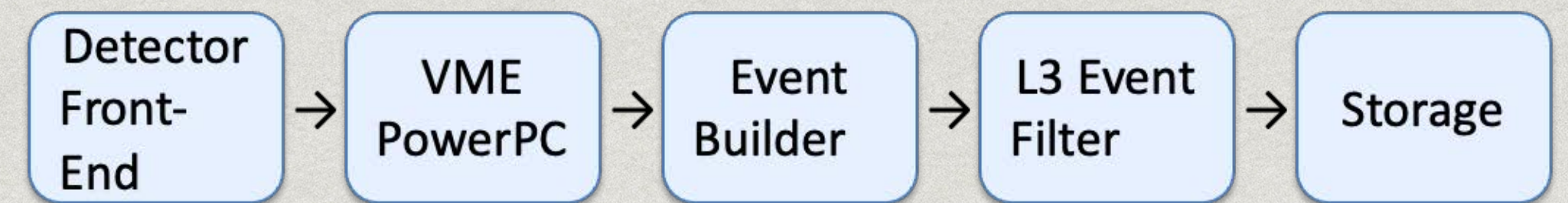

The BESIII DAQ system + CGEM

- * Key Parameters of the BESIII DAQ system

- * ~39 VME readout crates (~30k channels)

- * L1 trigger rate: 4 kHz

- * Average event size: ~14 kB

- * DAQ readout bandwidth: 80 MB/s

- * 42 IBM eServerBlade nodes

- * L3/Event filter → <1 kHz

- * ATLAS TDAQ-based software

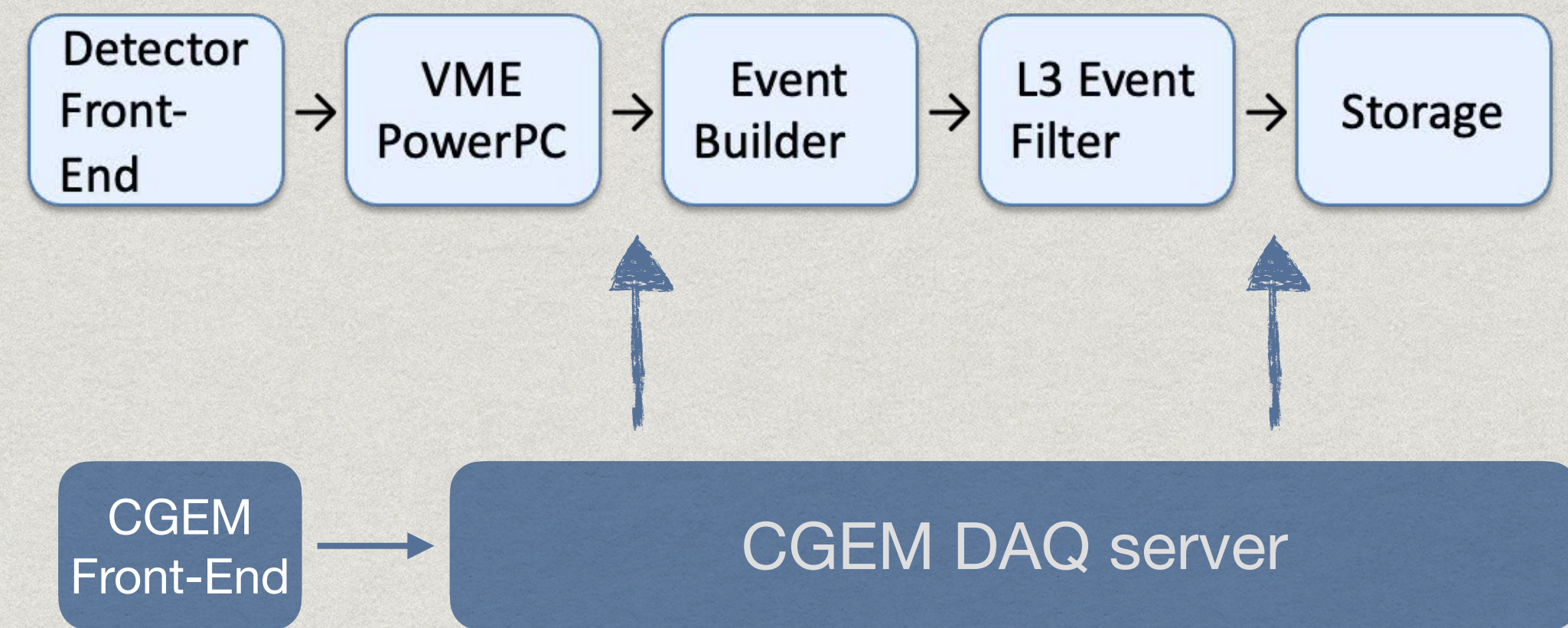

- * PowerEdge R7525 Server

- * 2 x AMD 7313, 3.0GHz, 16C/32T, 128M, 155W, 3200;

- * 2 x 32GB RDIMM, 3200MT/s, dual-rank 16Gb;

- * PERC H355 Front RAID Controller;

- * 2x 480GB SATA SSD, hot-swappable, mixed use, 6Gbps, 512, 2.5-inch AG HD

- * 4 x 1.2TB SAS ISE 12Gbps 10k 512n hard drives;

- * Broadcom 57414 Dual-port 10/25GbE SFP28, OCP NIC 3.0

The CGEM DAQ system: software

GUFI (Graphical User Frontend Interface)



* Key Functions of GUFI in CGEM-IT

- * **System Integration:** developed during testing with cosmic ray, and used in beam operations to integrate CGEM data streams into the main BESIII backend DAQ
- * **Electronics Configuration:** allows to configure the front-end TIGER ASICs and GEMROC off-detector modules
- * **Data Acquisition:** manages the setup and data flow for reading out the 3-layer cylindrical triple-GEM detector
- * **Online Monitoring:** features a graphical interface that provides real-time monitoring and debugging of trigger alignment, event timestamps, and detector noise

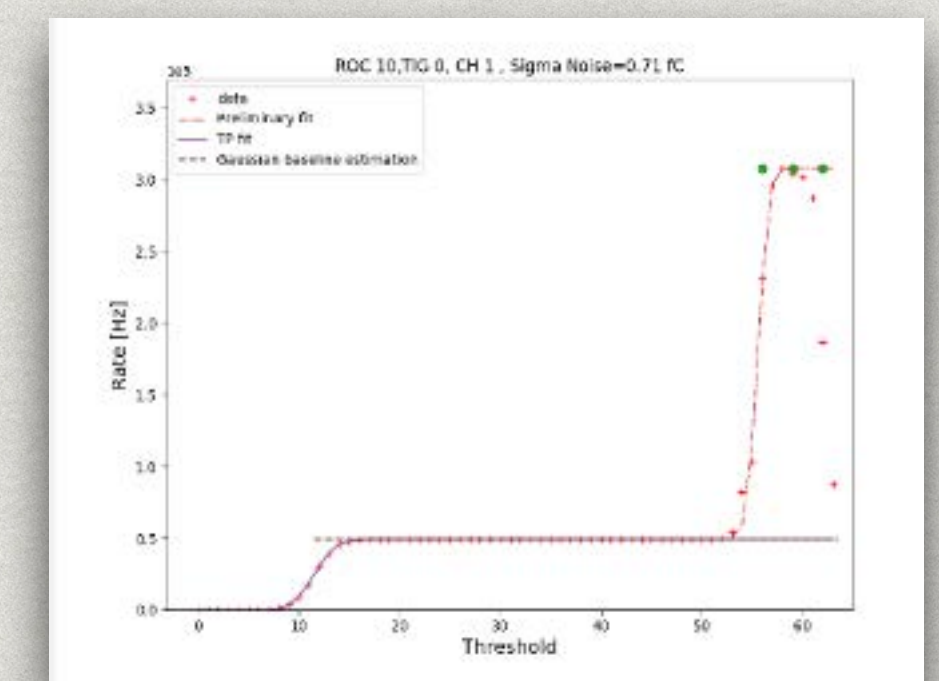
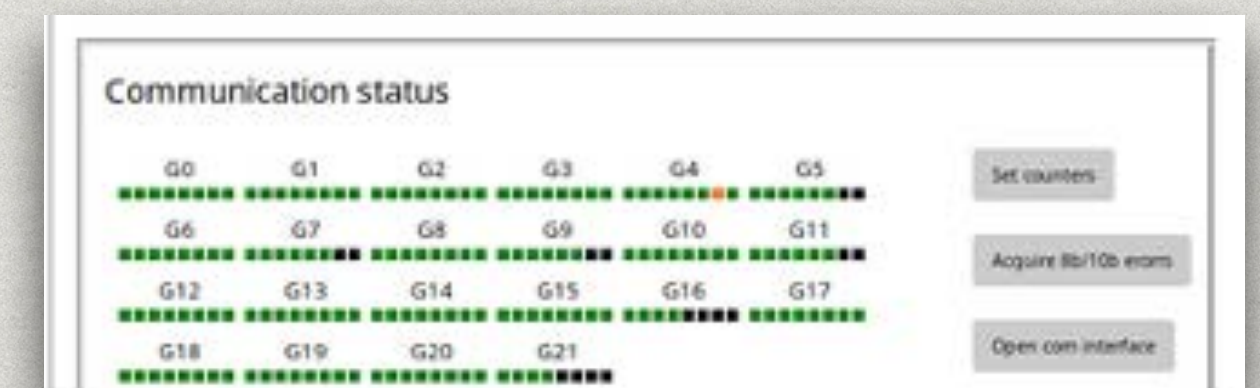
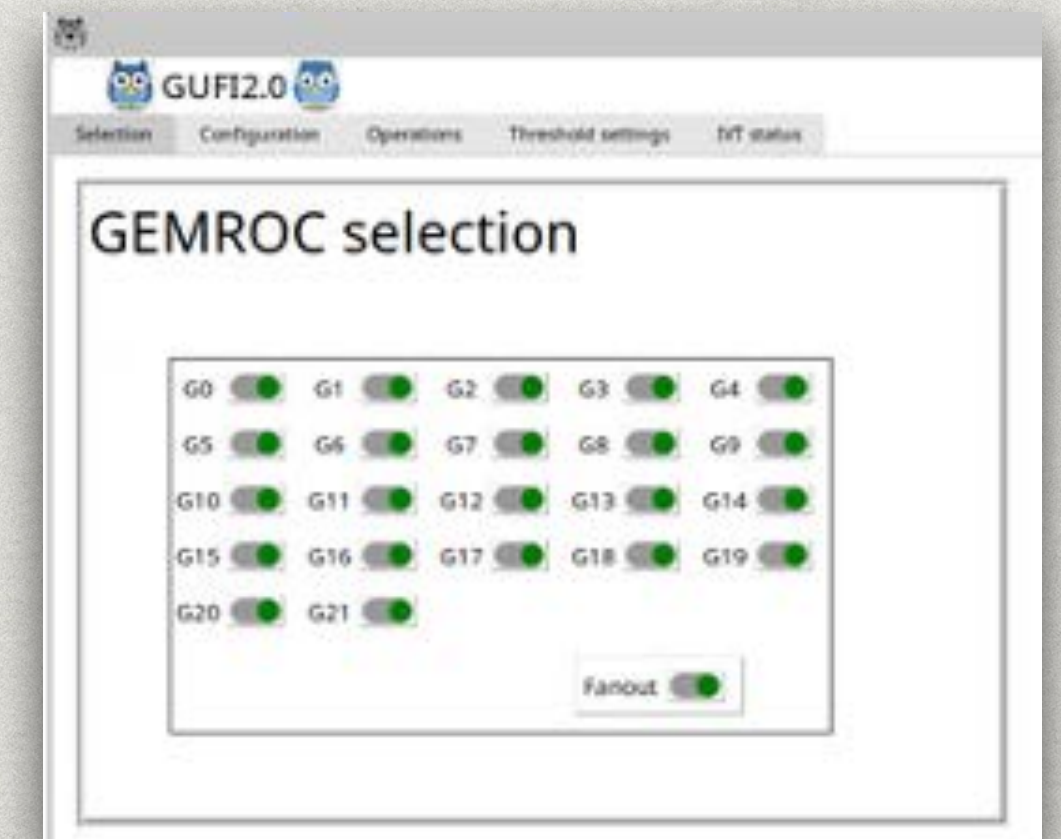

CGEM-BESIII DAQ INTEGRATION

- * Control interface
 - * A TCP server receive line commands (START <run_id>, STOP, CONFIG, ecc.) from external clients and add them to a queue for execution on independent threads
 - * Success/error messages are generated for each command

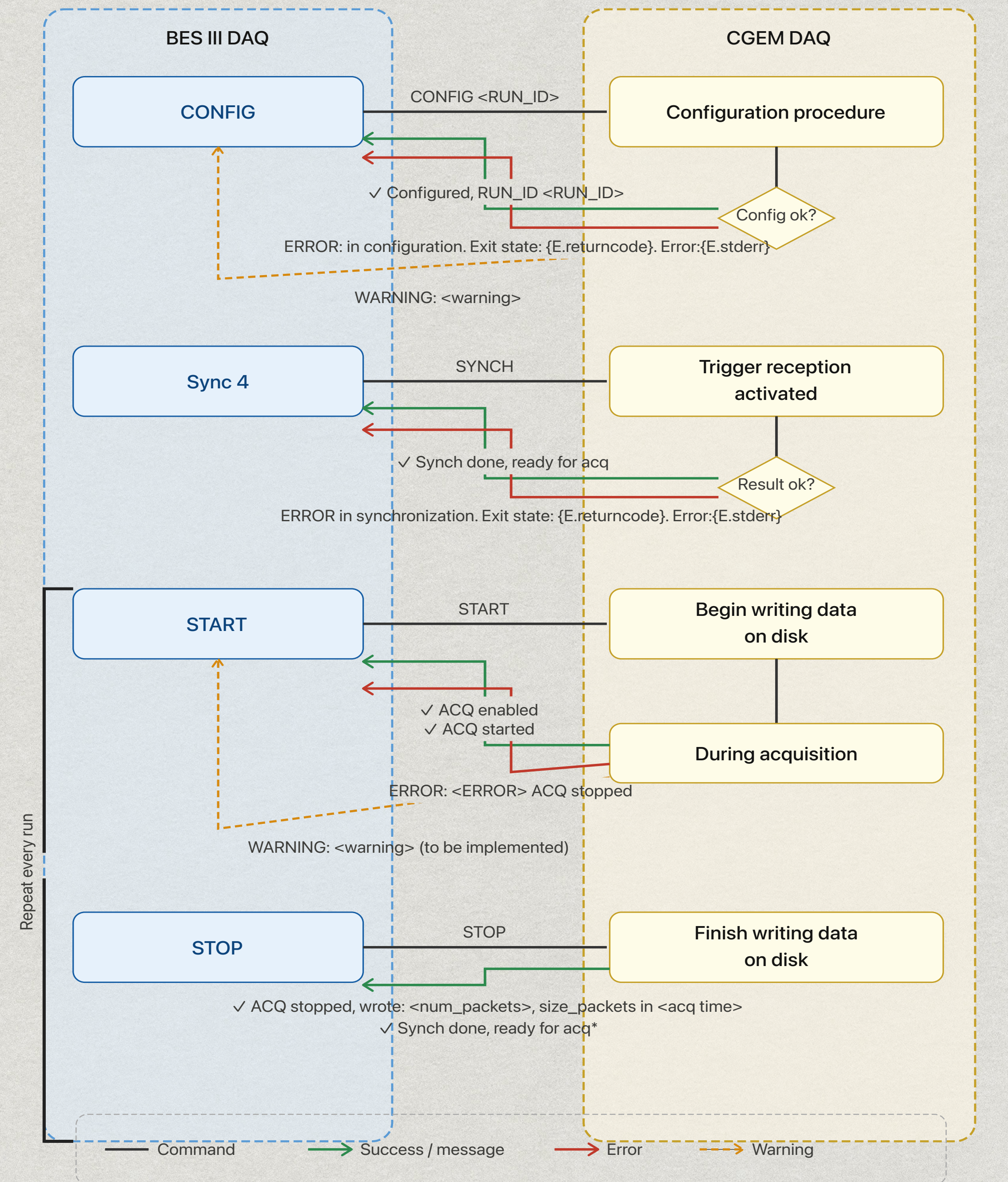

CGEM-BESIII DAQ INTEGRATION

- * Data flow

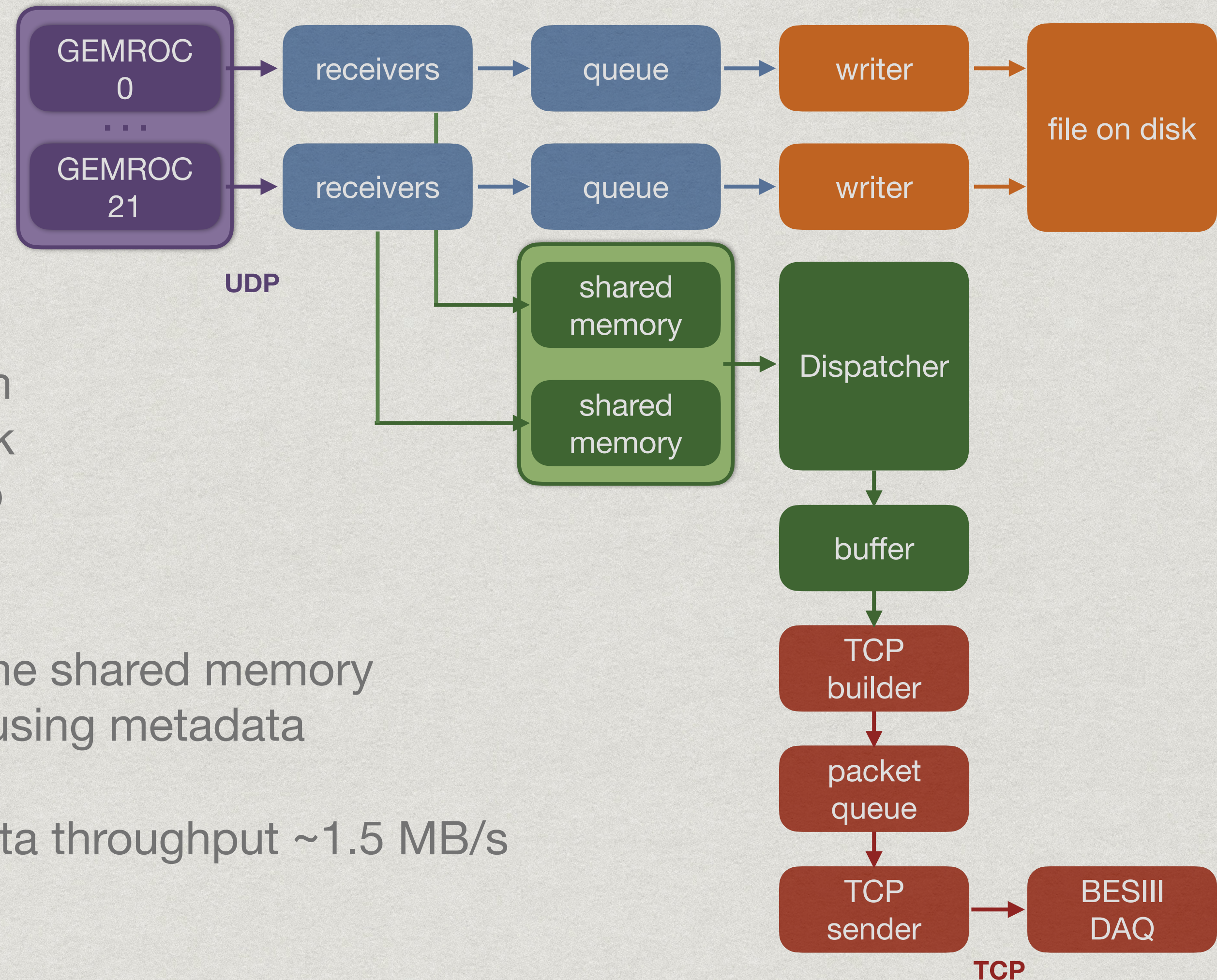

- * The system handles parallel data acquisition from GEMROCs through two independent paths: one for disk storage and one for transmission to an external DAQ system via TCP
- * Raw data are copied only once in the shared memory --> the CGEM event is assembled using metadata
- * CGEM event size ~1.5 kB - total data throughput ~1.5 MB/s

CGEM-BESIII DAQ INTEGRATION

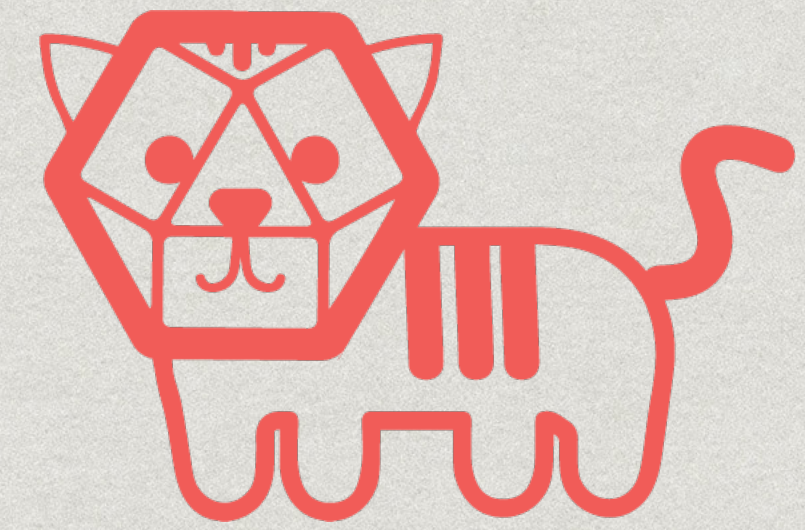

- * DAQ monitoring with InfluxDB + Telegraf
 - * During acquisition, the system publishes continuously diagnostic data on InfluxDB
 - * **Increasing buffer_to_analyze** → Dispatcher lagging behind receivers → possible data loss risk
 - * **Increasing dispatcher_buckets_length** → incomplete events (missing GEMROCs / timeout issues)
 - * **Increasing queue sizes** → TCP_packet_builder or TCP_sender bottleneck
 - * **Per-GEMROC trigger_rate** → identifies silent or abnormal GEMROC modules
 - * **High send_rate_max** → TCP transmission latency spikes toward BESIII DAQ

Operation experience and detector performance

- * In 2025, detector, electronics and the DAQ have been commissioned using data at the $\psi(2S)$ peak
 - * Overall good stability of the DAQ system
 - * No particular synchronization issues
 - * TCP merging still under test
- * Alignment has been performed using Bhabha tracks from the external MDC
- * Preliminary offline software reconstruction

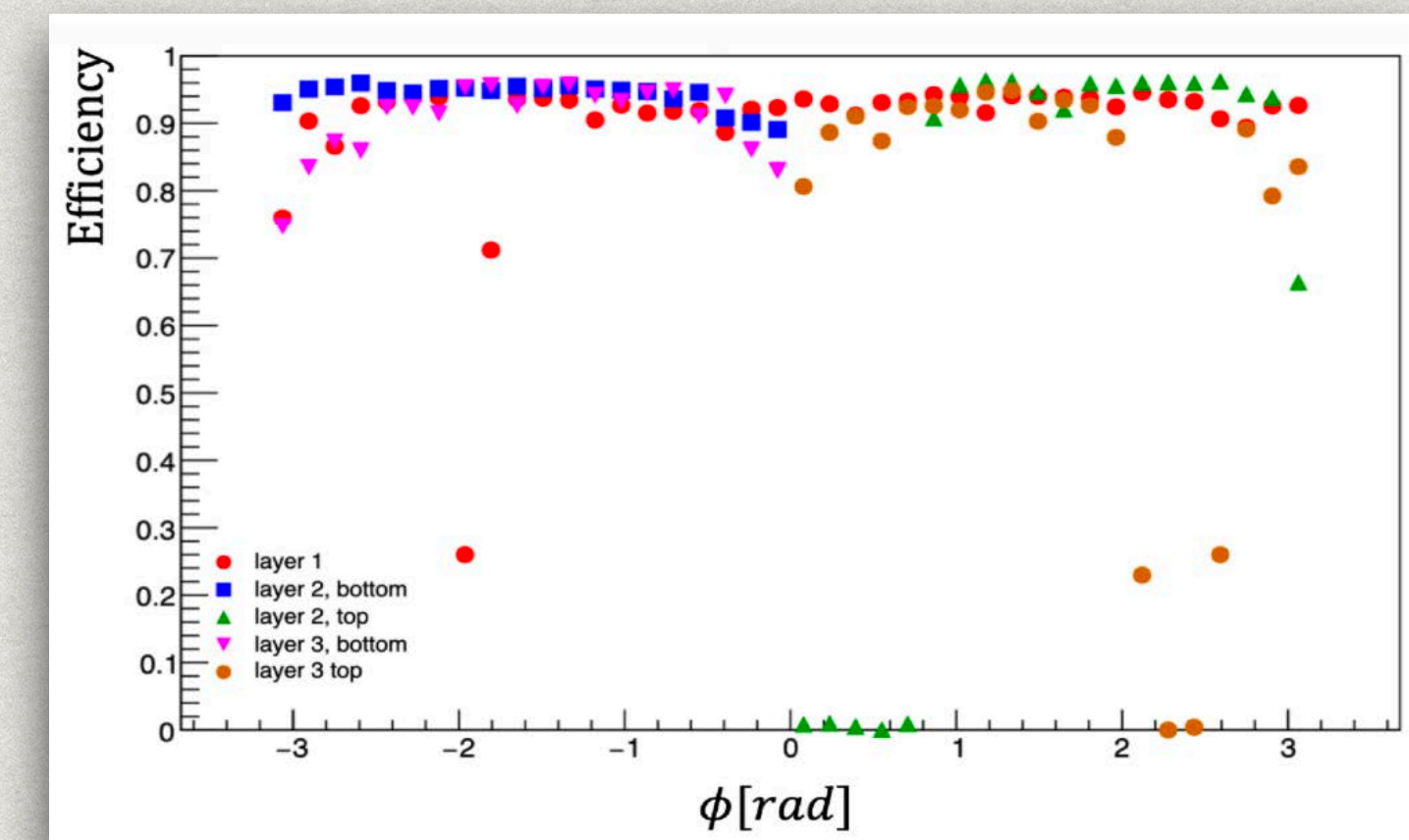
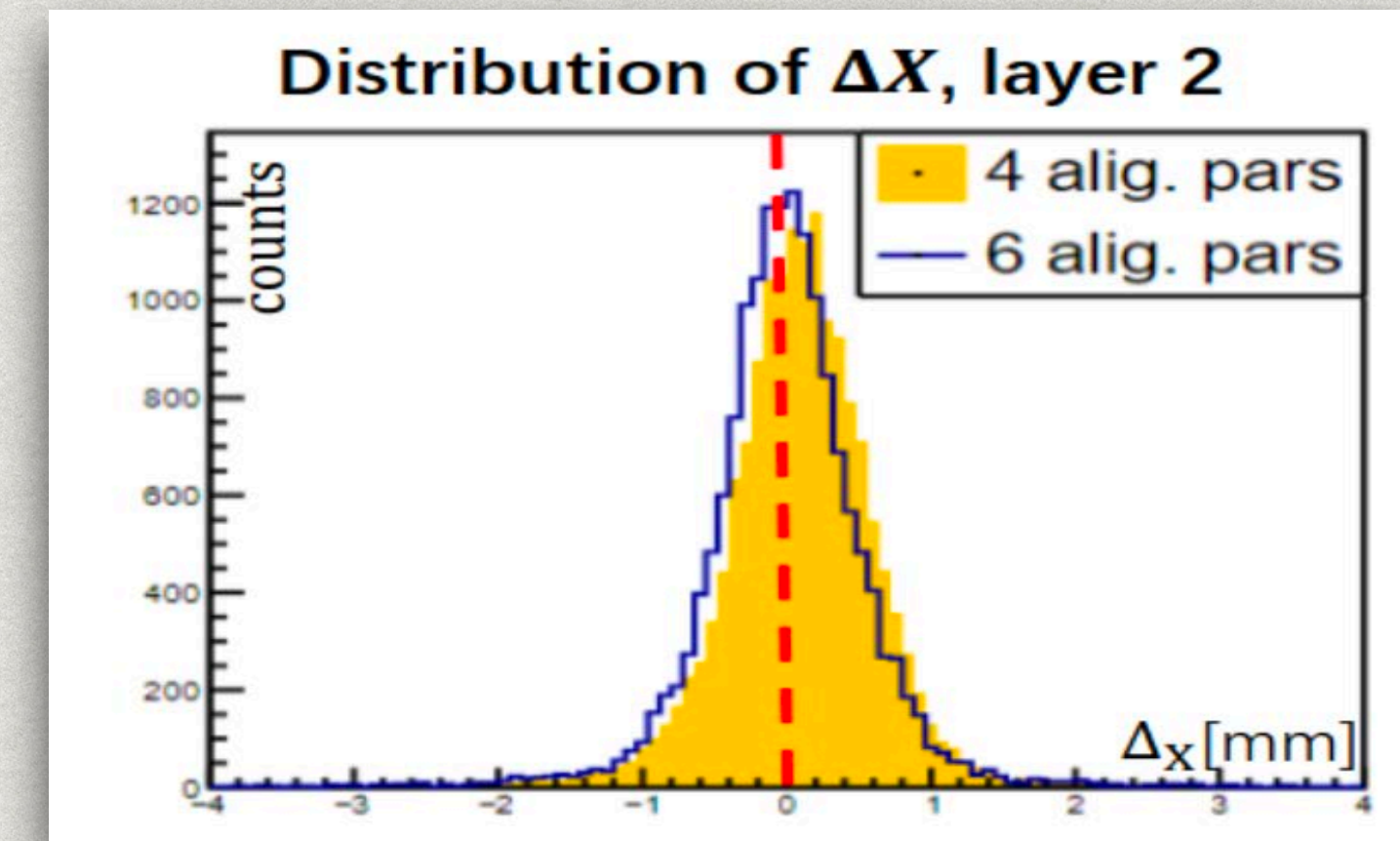

Summary and outlook

- * The Cylindrical GEM Inner Tracker has been installed in BESIII experiment at the end of 2024
- * Due to a delay in the VME Data Concentrators development the collaboration decided to integrate the CGEM GUFU-based DAQ system into the global BESIII Data Acquisition
 - * The integration has been successfully implemented in two steps: with offline and online data merging
 - * Smooth commissioning and reliable data taking performance
- * The BESIII TIGER-GEMROC-GUFU readout system has been successfully tested on other detectors such as different MPGDs, wire chambers, semiconductor sensors

Tracking with uRWELL

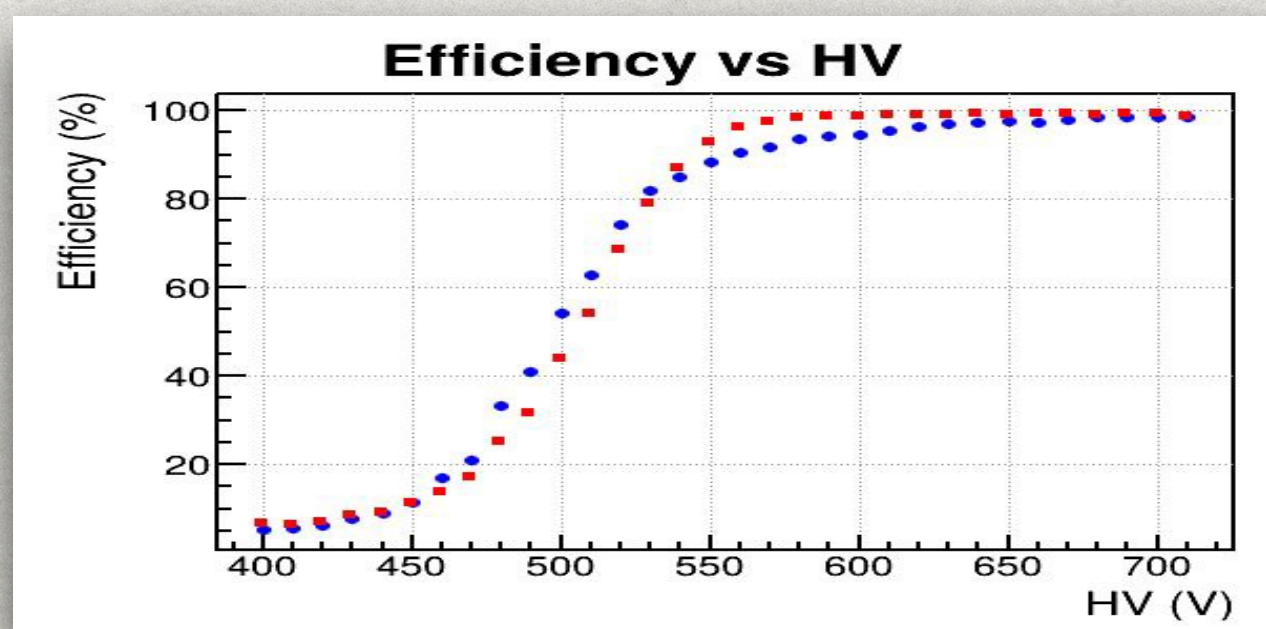

Time distribution with Drift Chamber

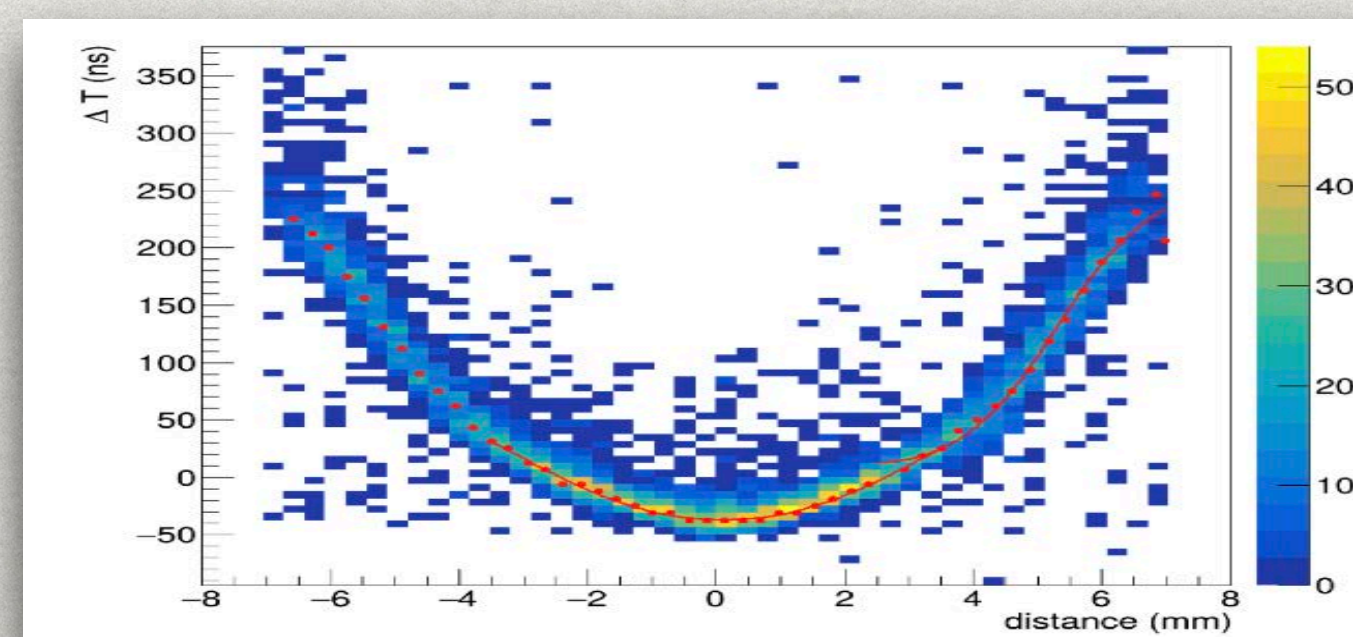

Gamma spectroscopy with CdZnTe

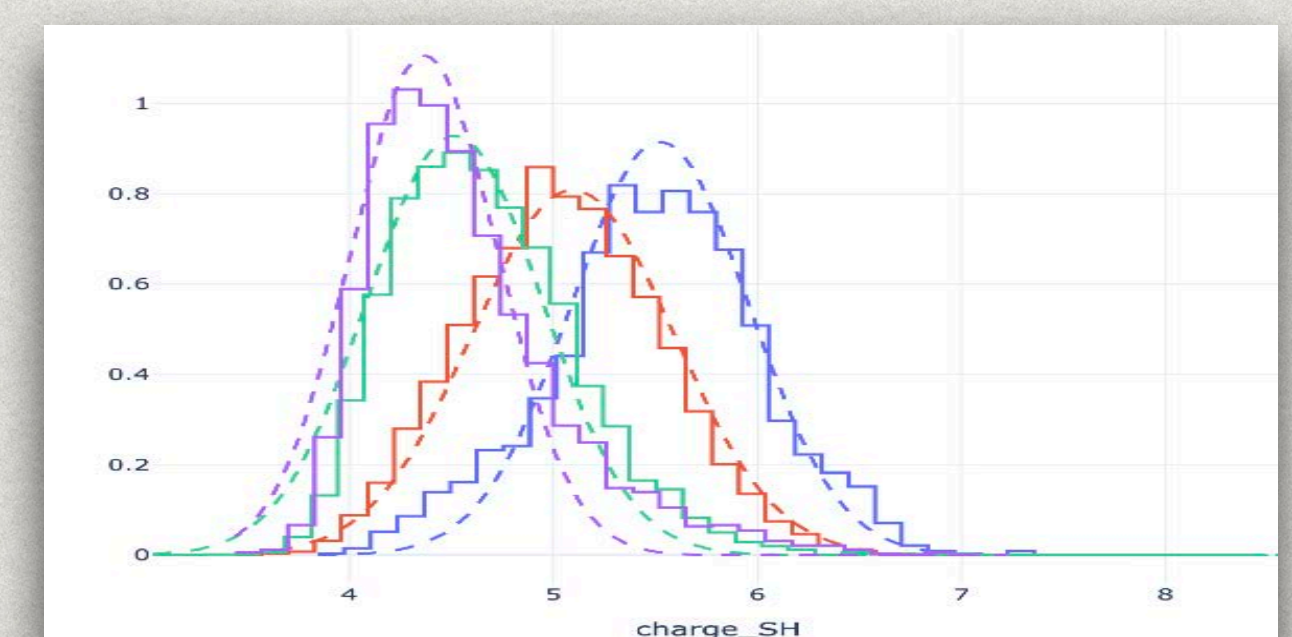



THANKS FOR YOUR ATTENTION

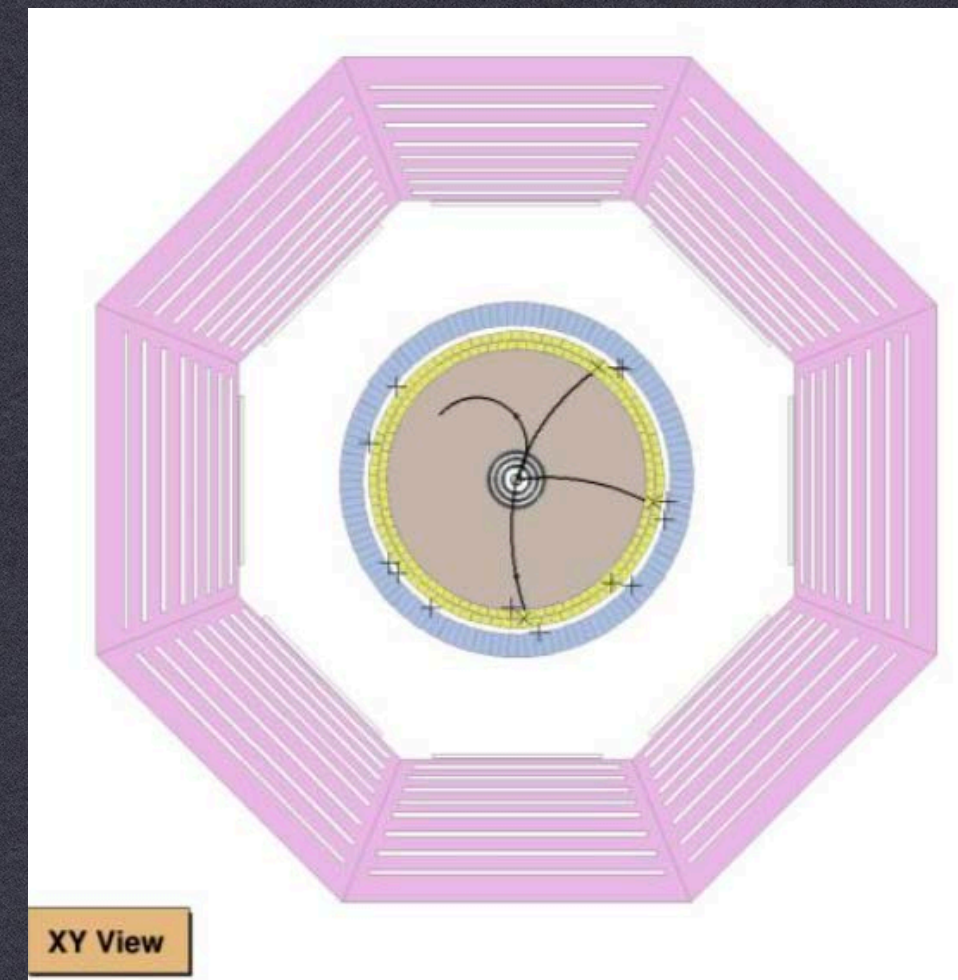
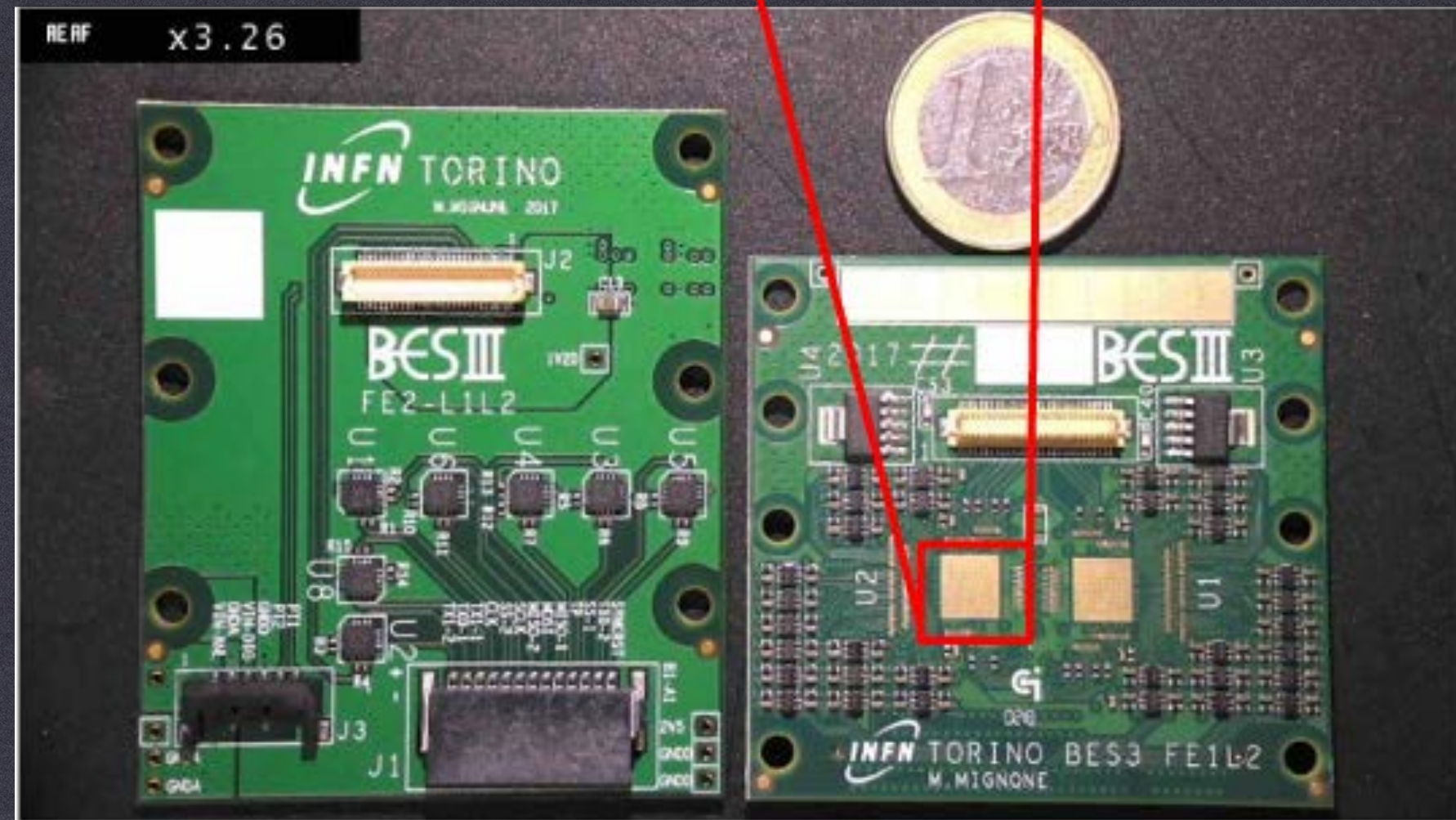
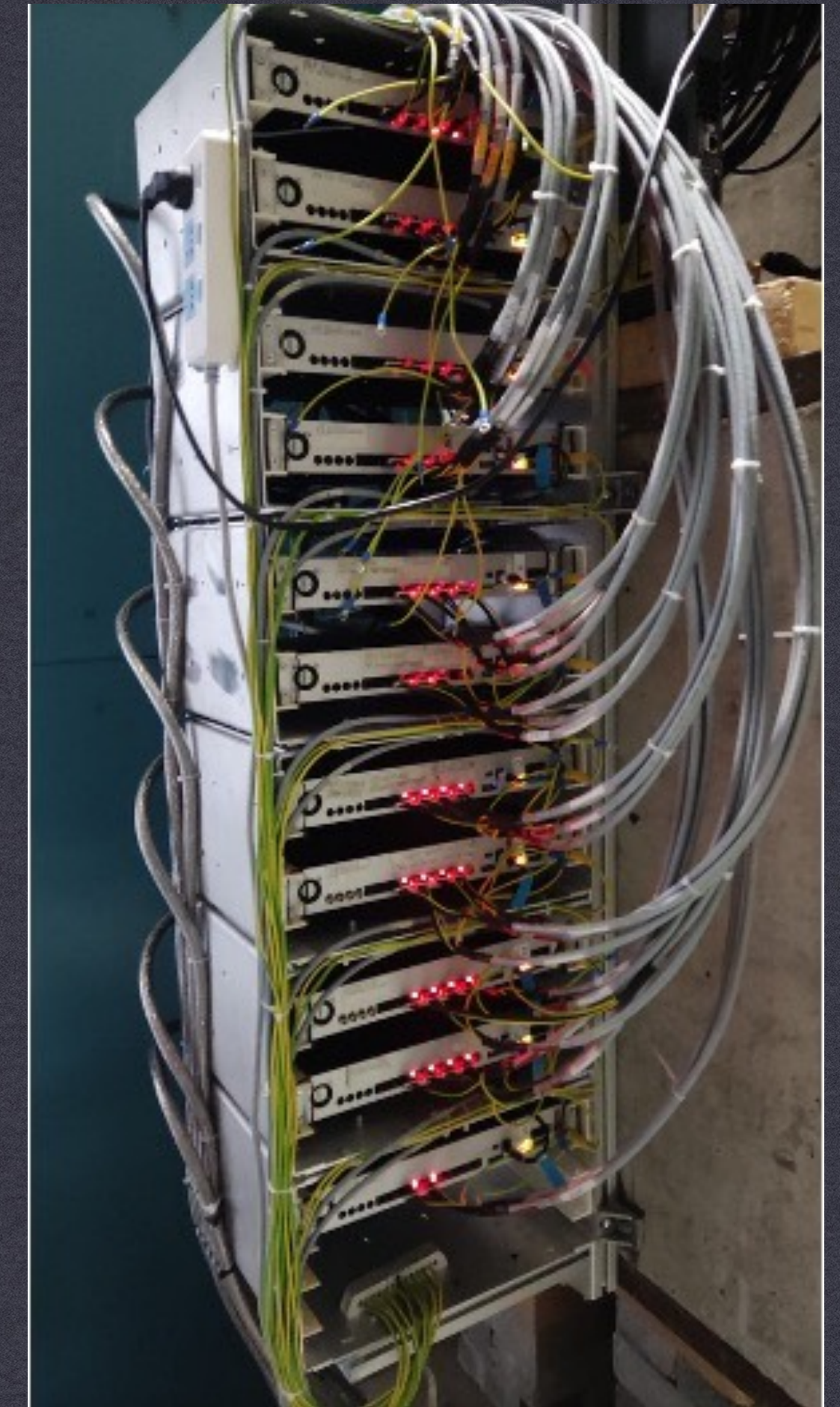
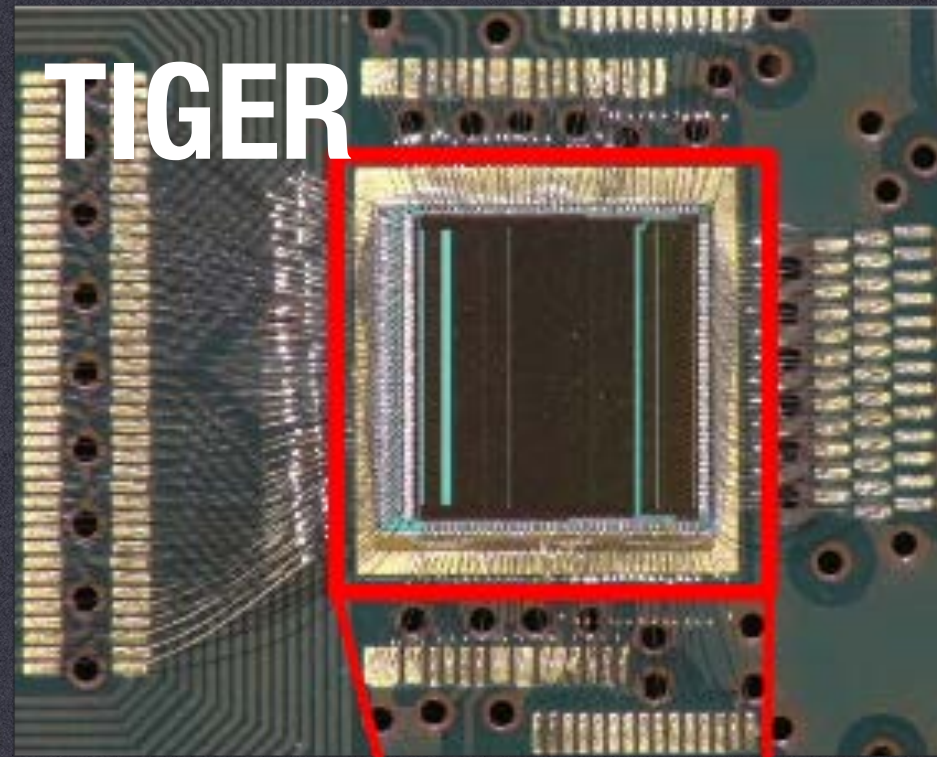

THANKS FOR YOUR ATTENTION

Channel by channel noise calibration

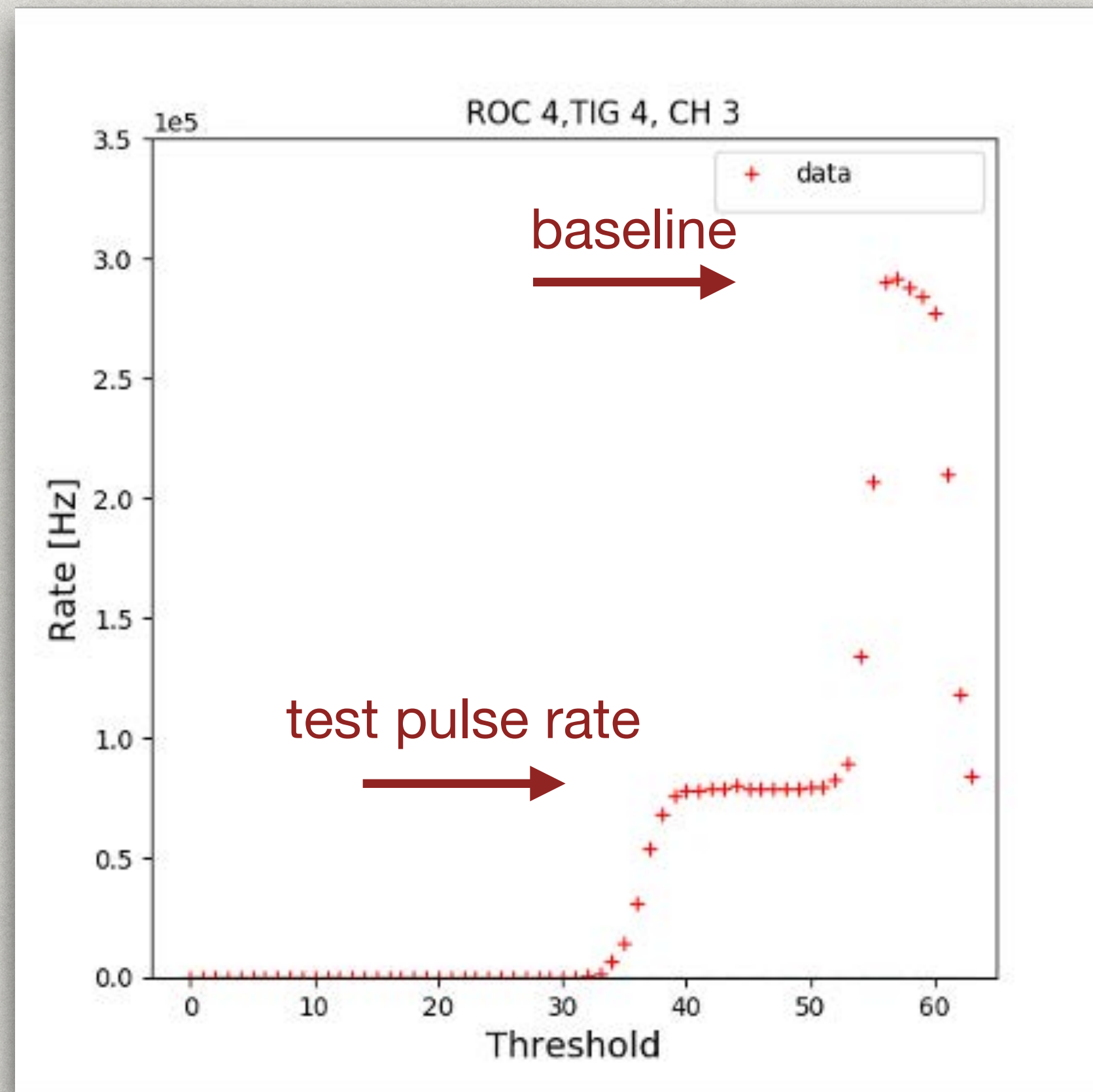

toward lower threshold \longrightarrow

- * Inject a fixed number of analog test pulse of known amplitude
- * Fit the full shape to extract S-curve (from TP rise) and baseline
- * Used to set the thresholds on both T and E channels

Noise distributions

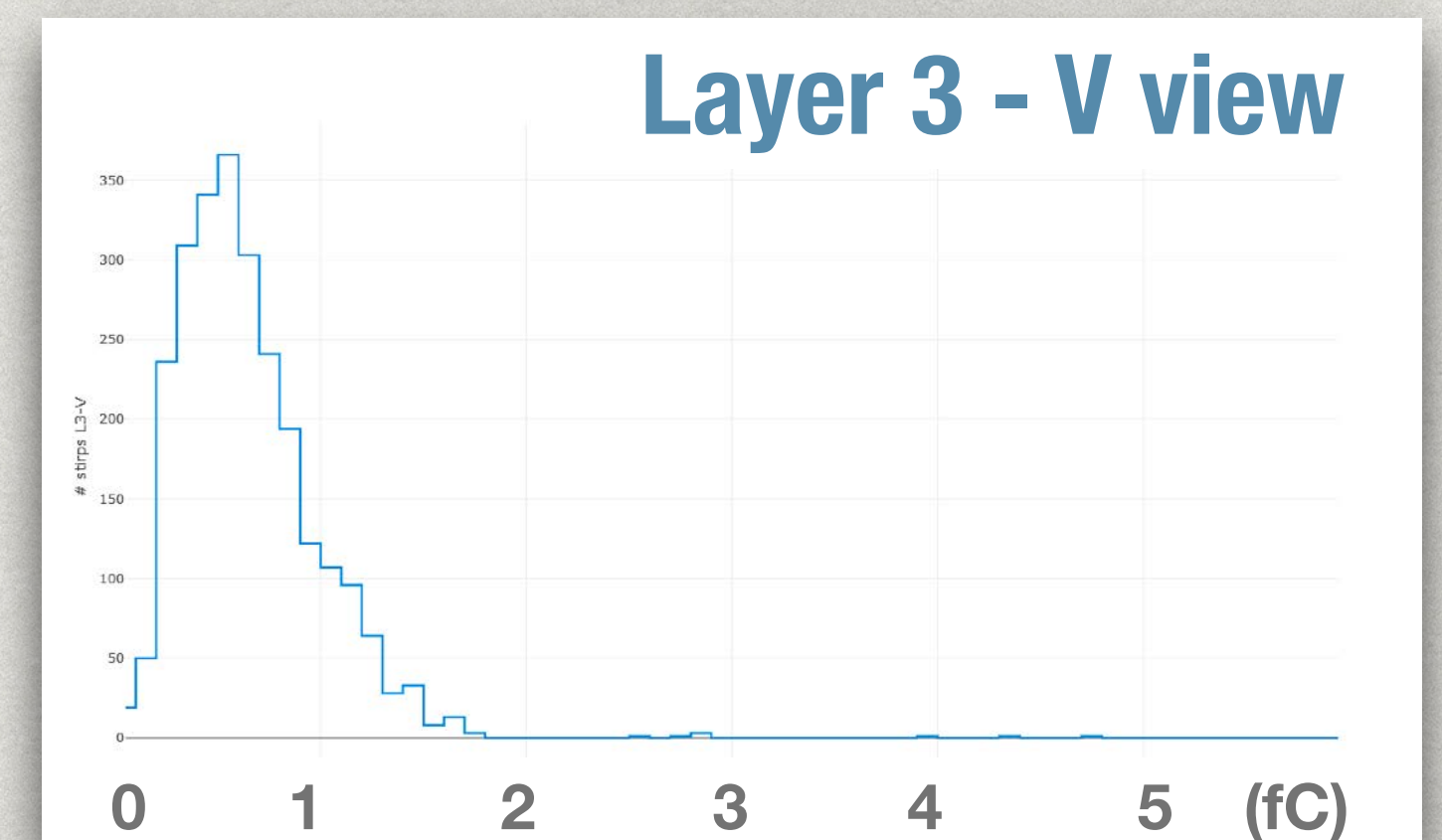
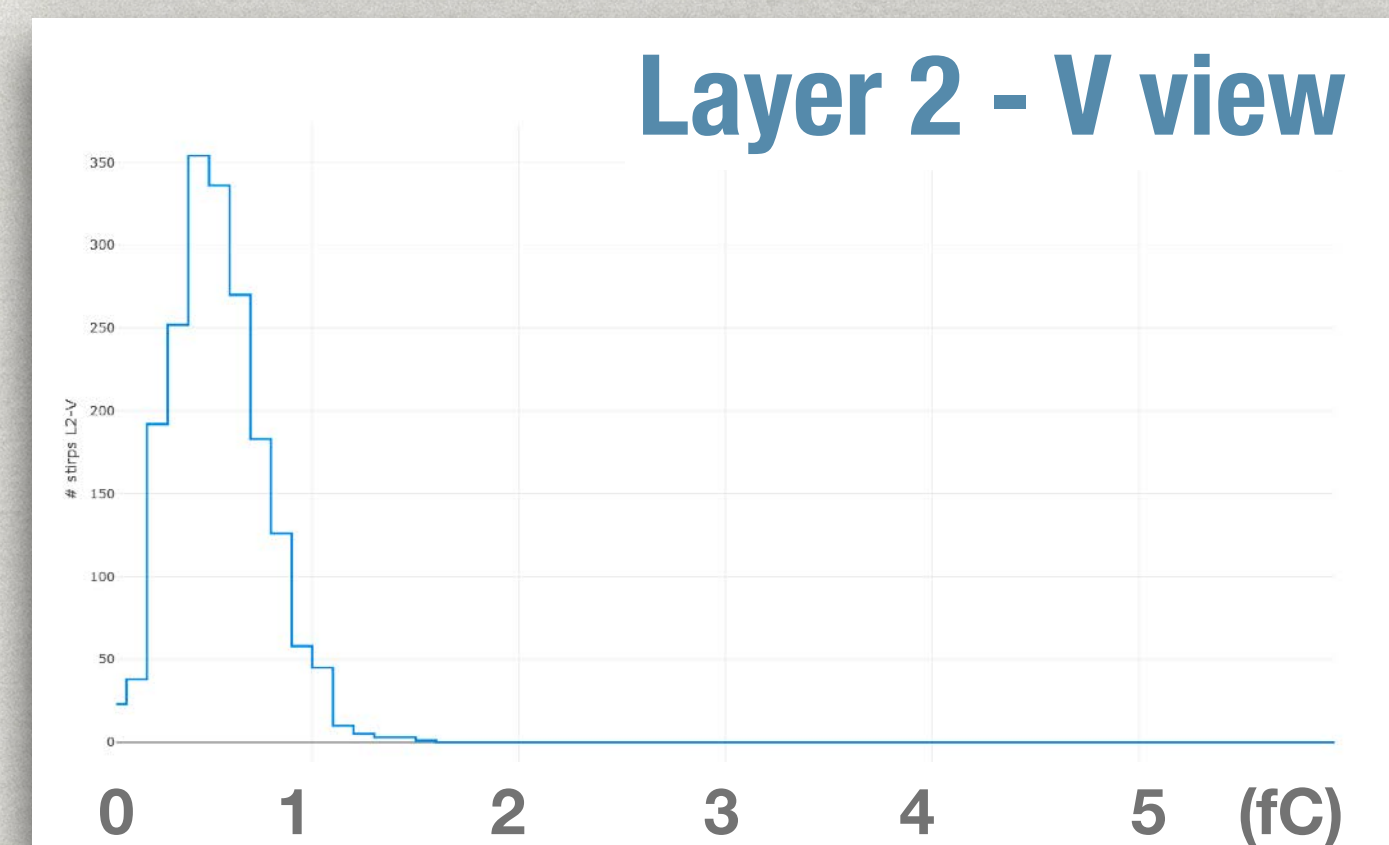
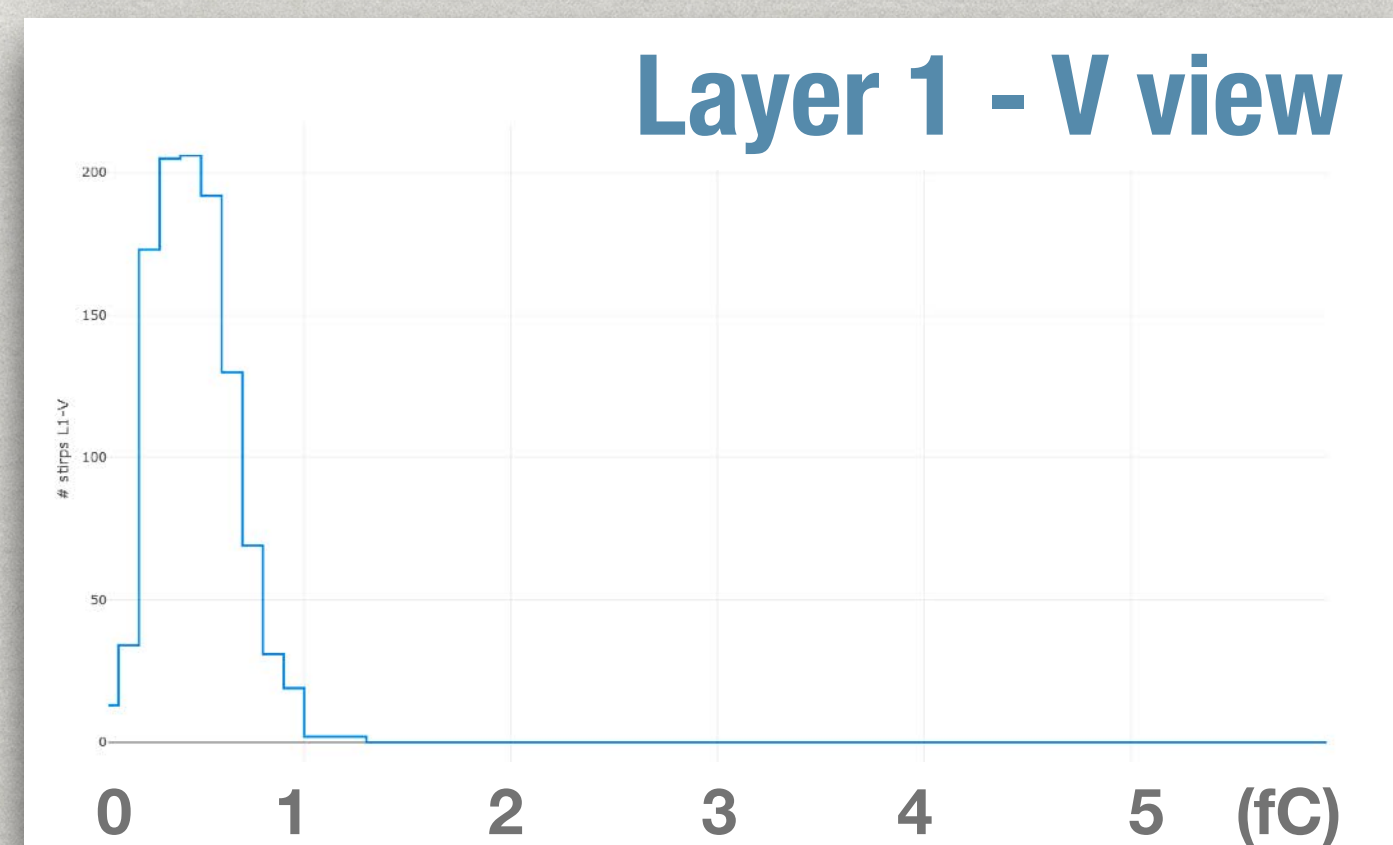
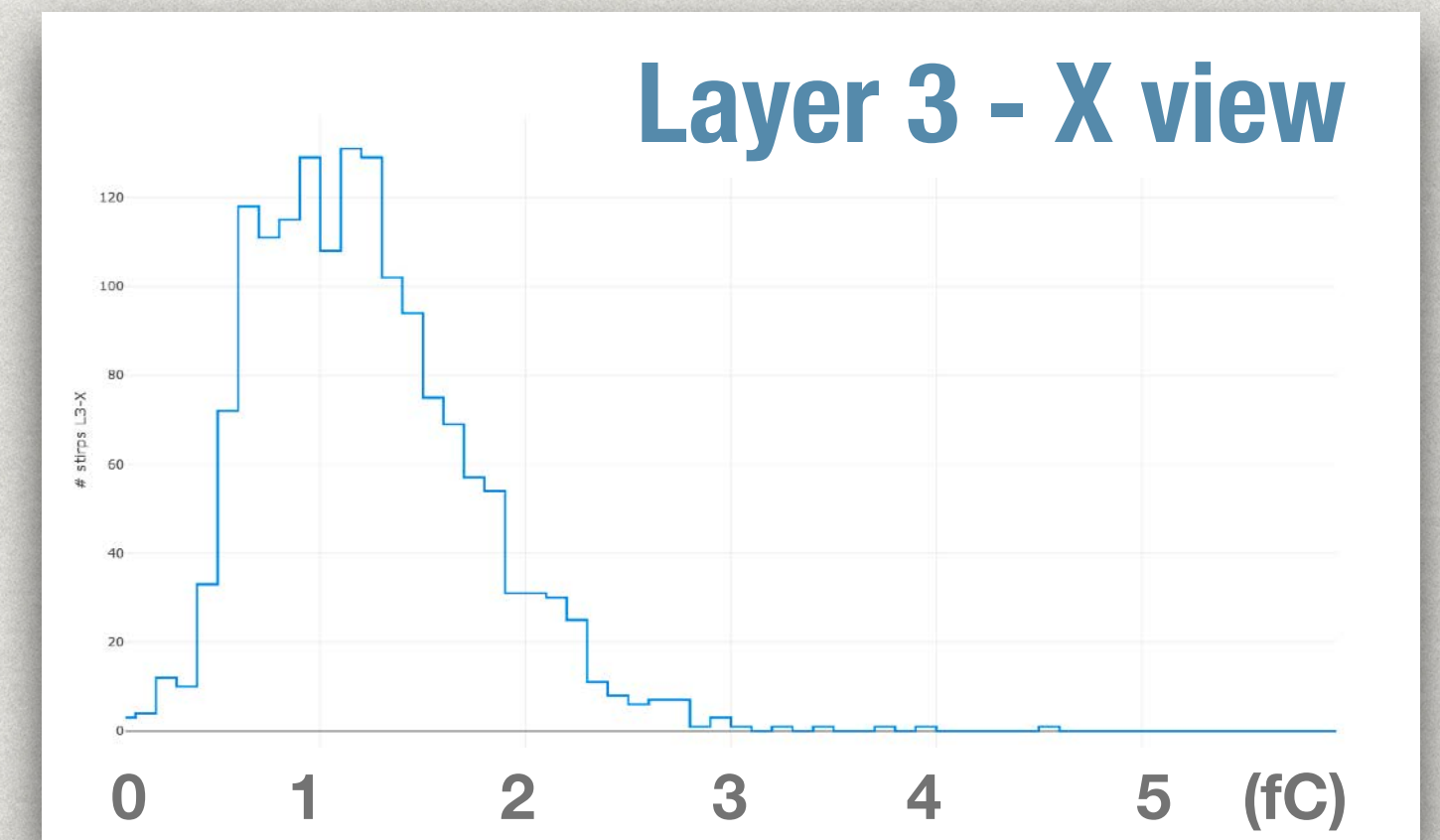
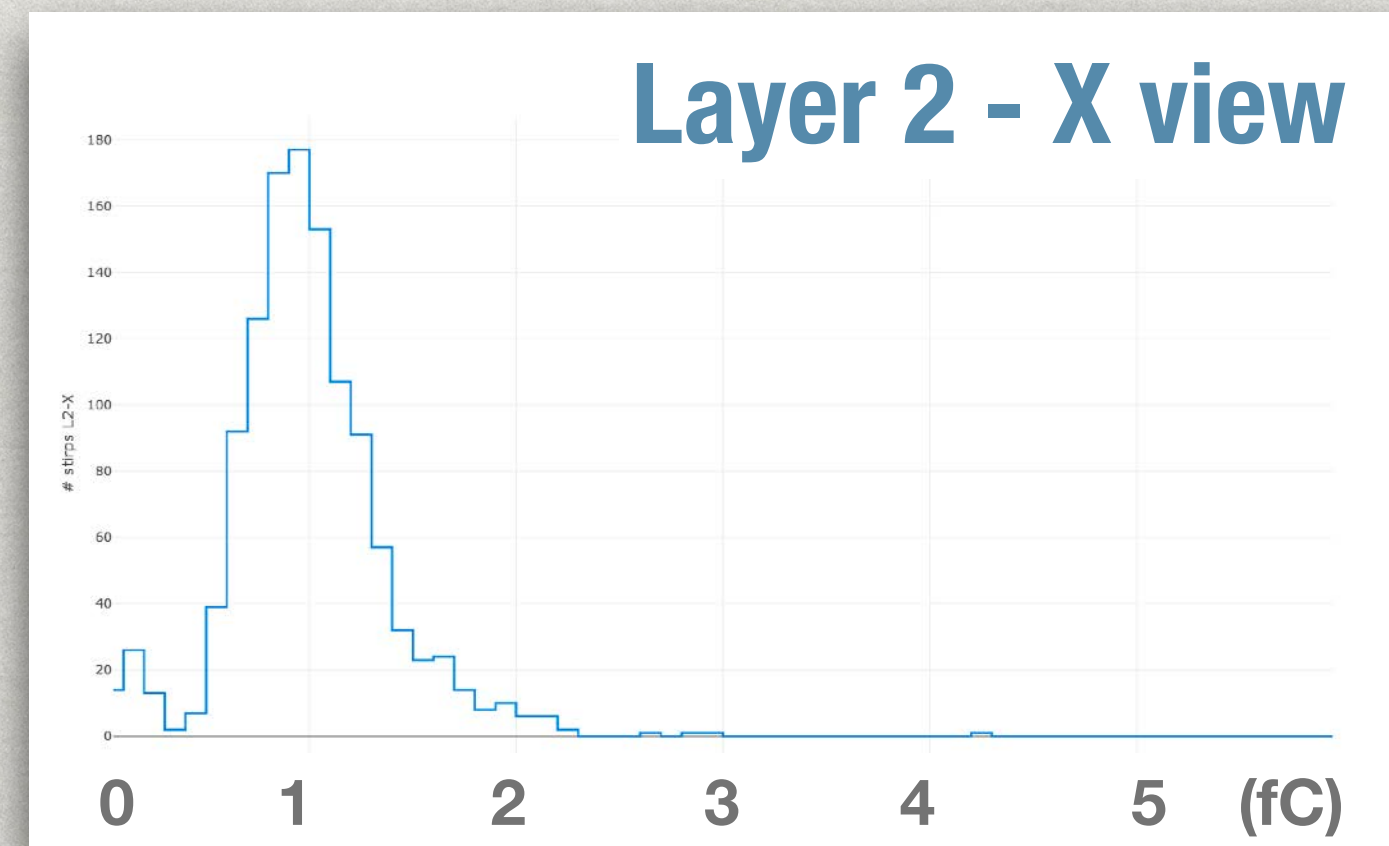
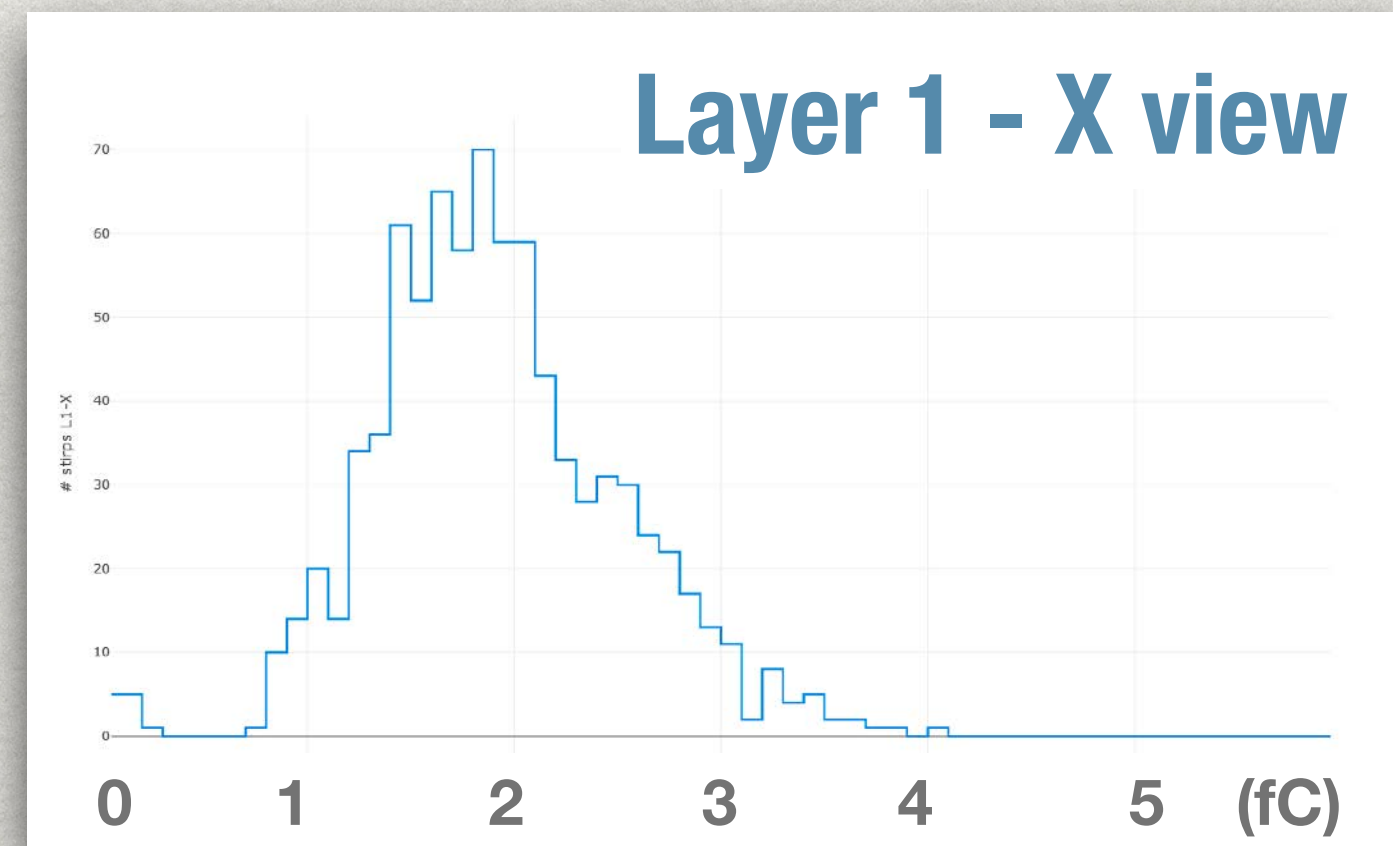

Detector operations

Detector currents vs time

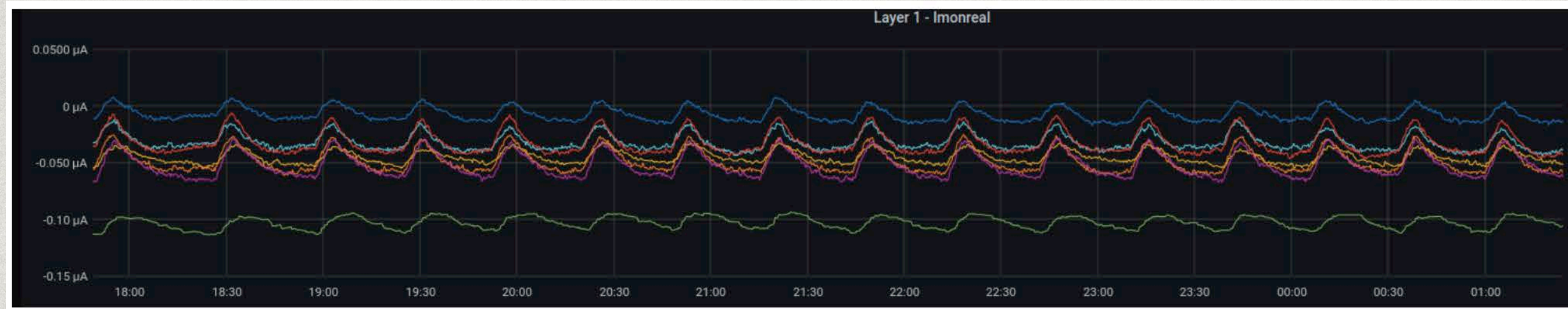

layer 1



layer 2



layer 3

Charge per strip distribution

charge (fC) ↑

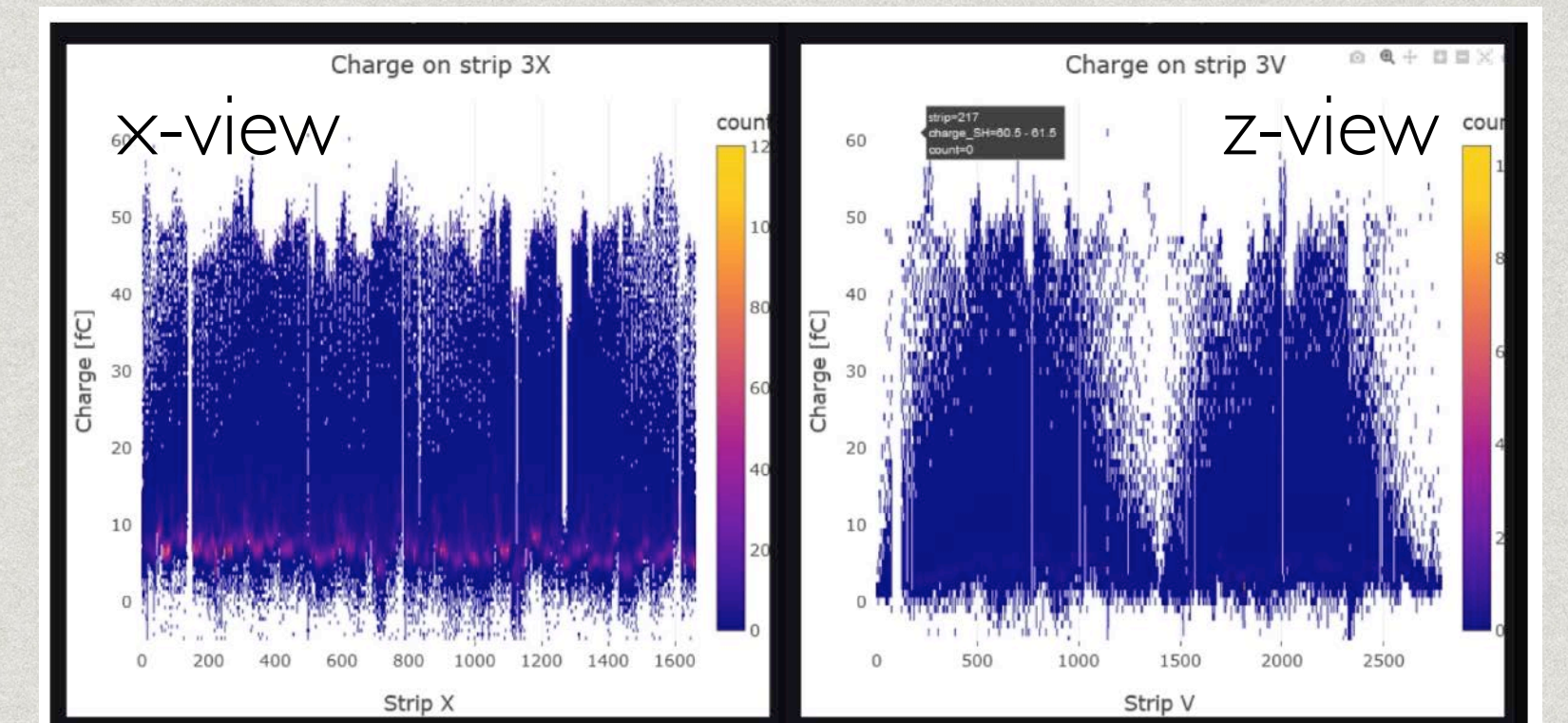
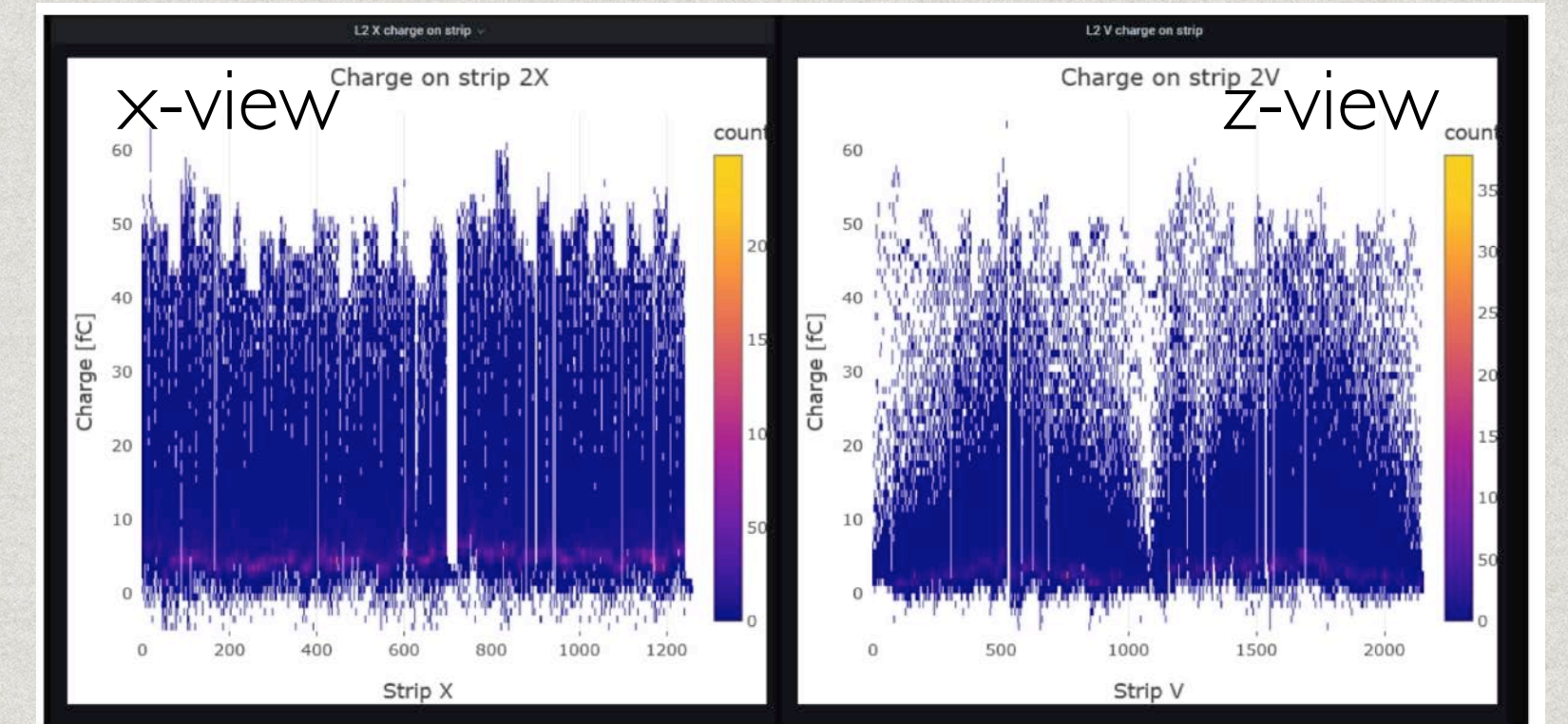
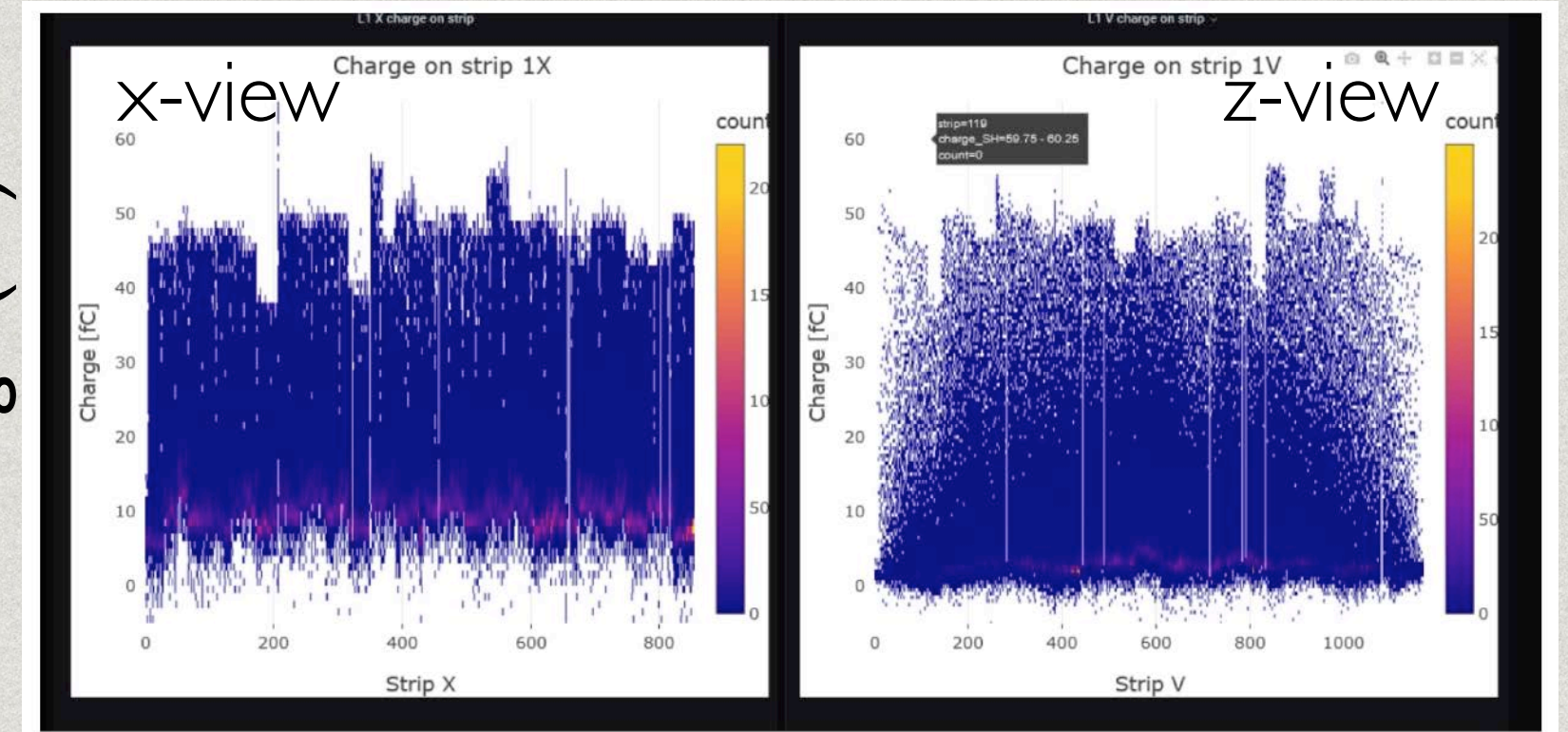

strip number →

Performance evaluation with cosmics: hits

- * Signal clearly visible in charge vs time distribution

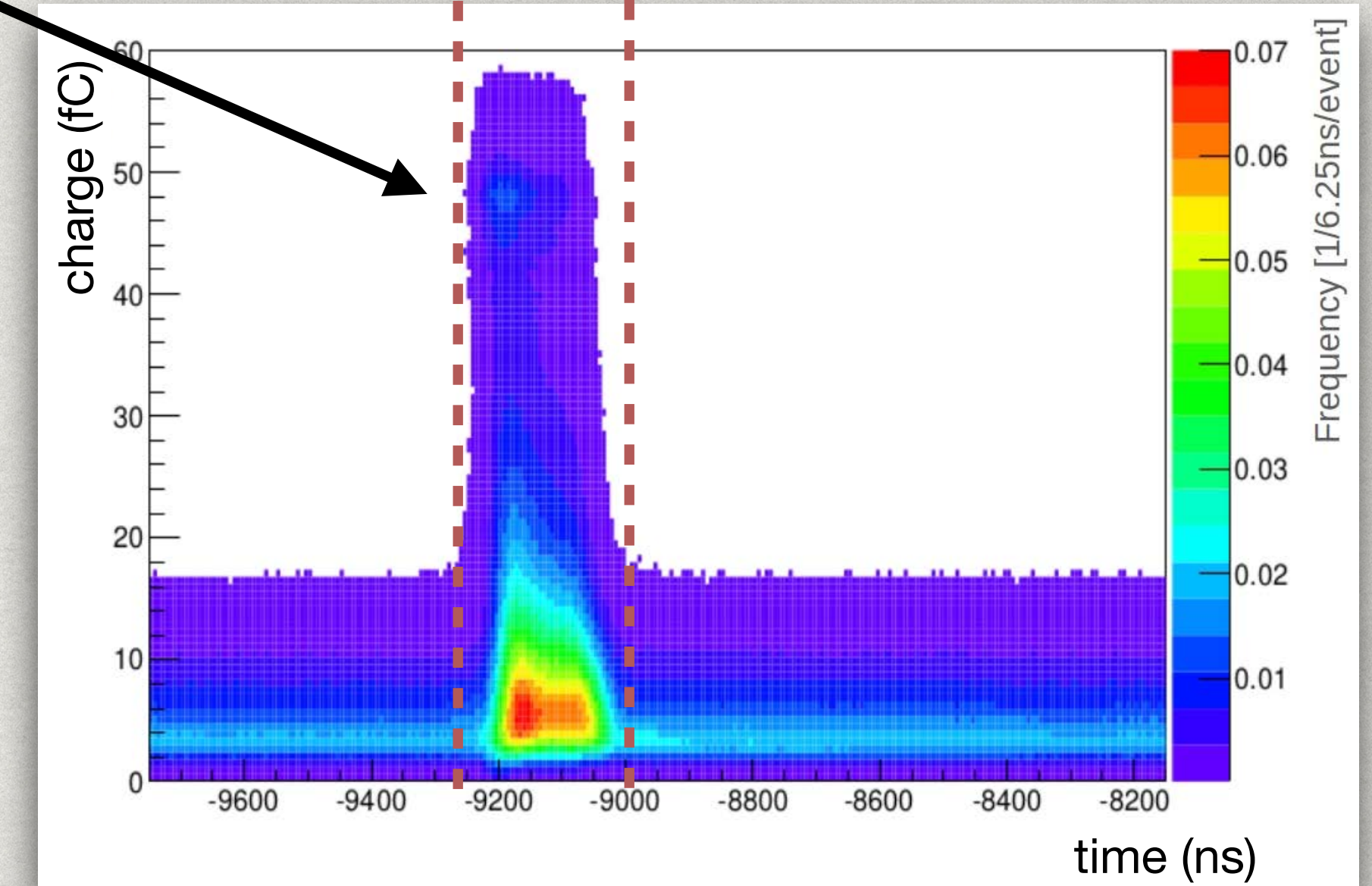
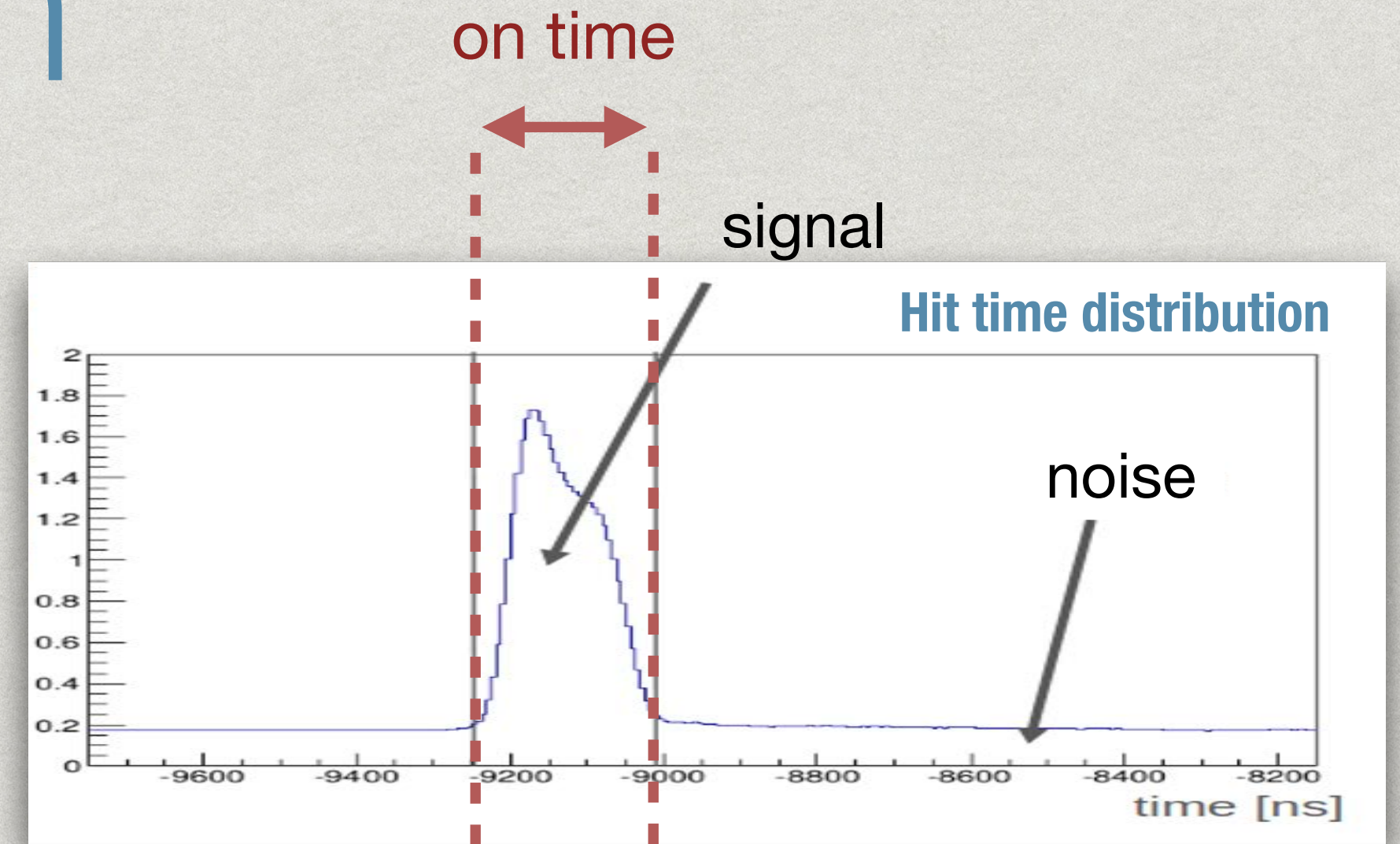
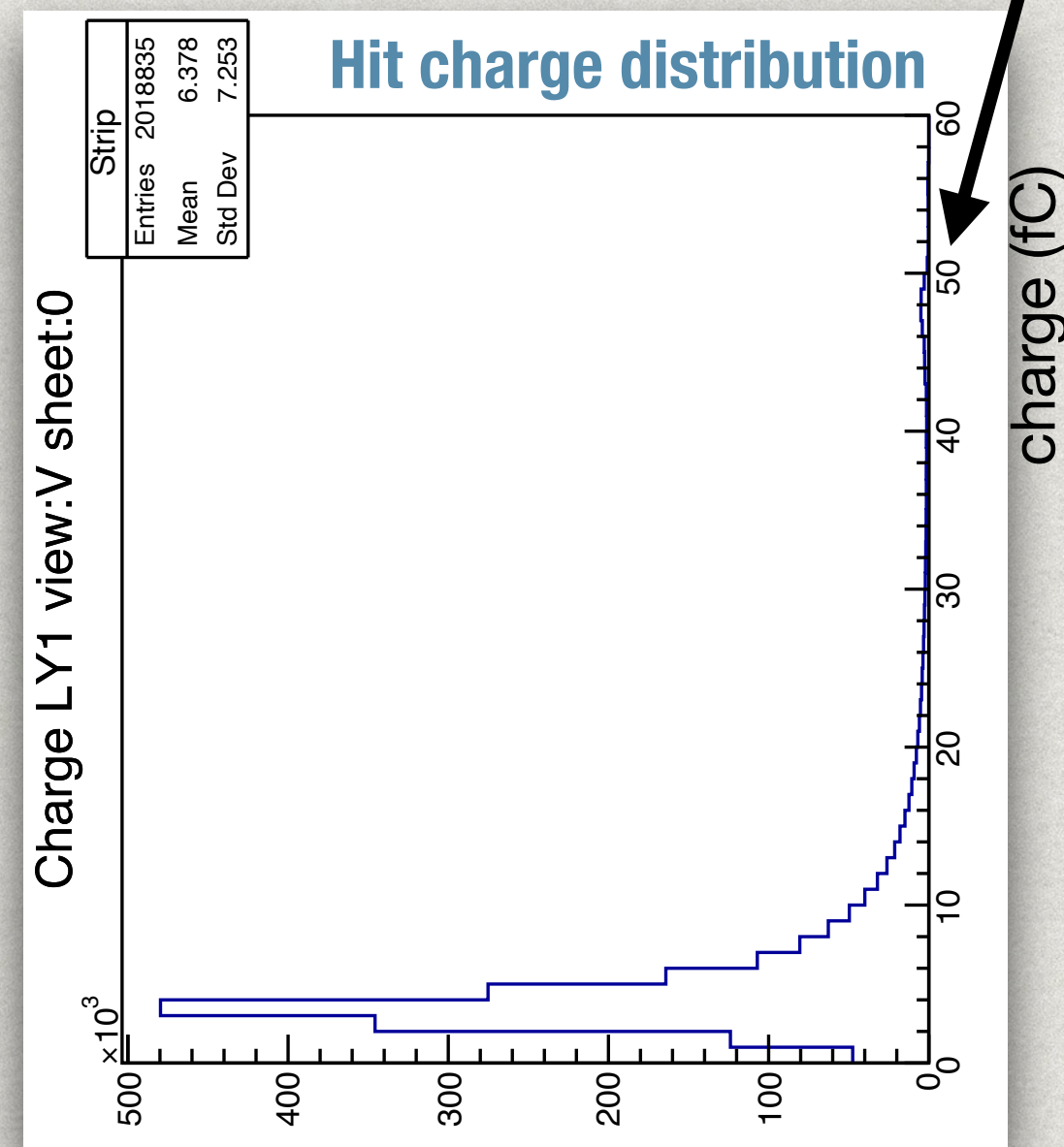

Performance evaluation with cosmics

