

# Development of the IDROGEN White Rabbit system for SuperKEKB and future project at KEK

H. Kaji, A. Aryshev, T. Kobayashi, K. Popov, T. Yamaguchi (KEK),  
A. Back, D. Charlet, C. Esnault, A. Martens, F. Zomer (IJCLab)

White Rabbit is a precise clock synchronization system among the distant circuits based on open-hardware.

Several applications in large scientific field

- Accelerator timing system
- DAQ for telescope array

We aim to use it as the RF clock generator for accelerators.

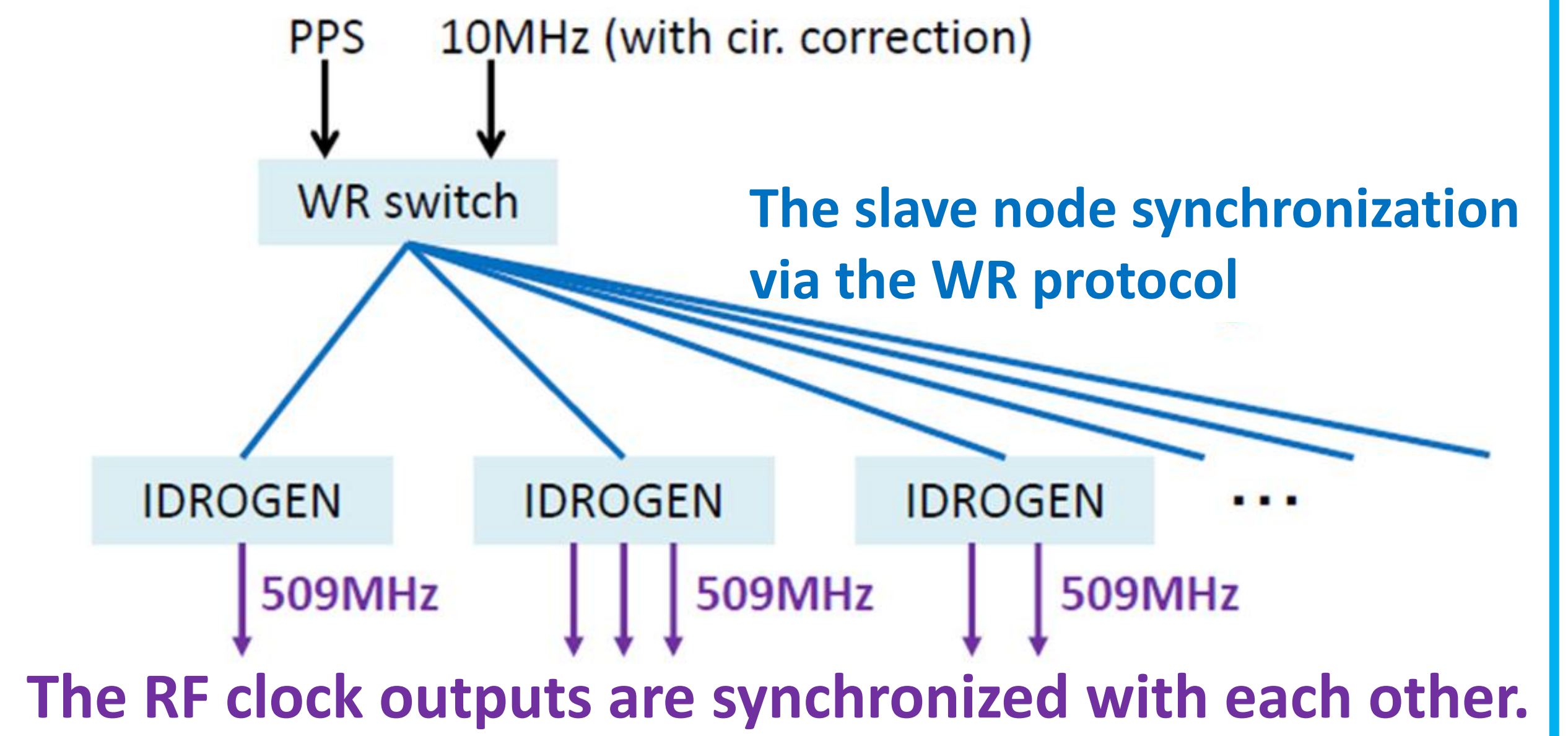

## IDROGEN, developed by IJCLab

Please visit, [https://indico.ijclab.in2p3.fr/event/11115/attachments/24957/36558/WR-IJCLab\\_2025\\_01\\_30.pdf](https://indico.ijclab.in2p3.fr/event/11115/attachments/24957/36558/WR-IJCLab_2025_01_30.pdf)

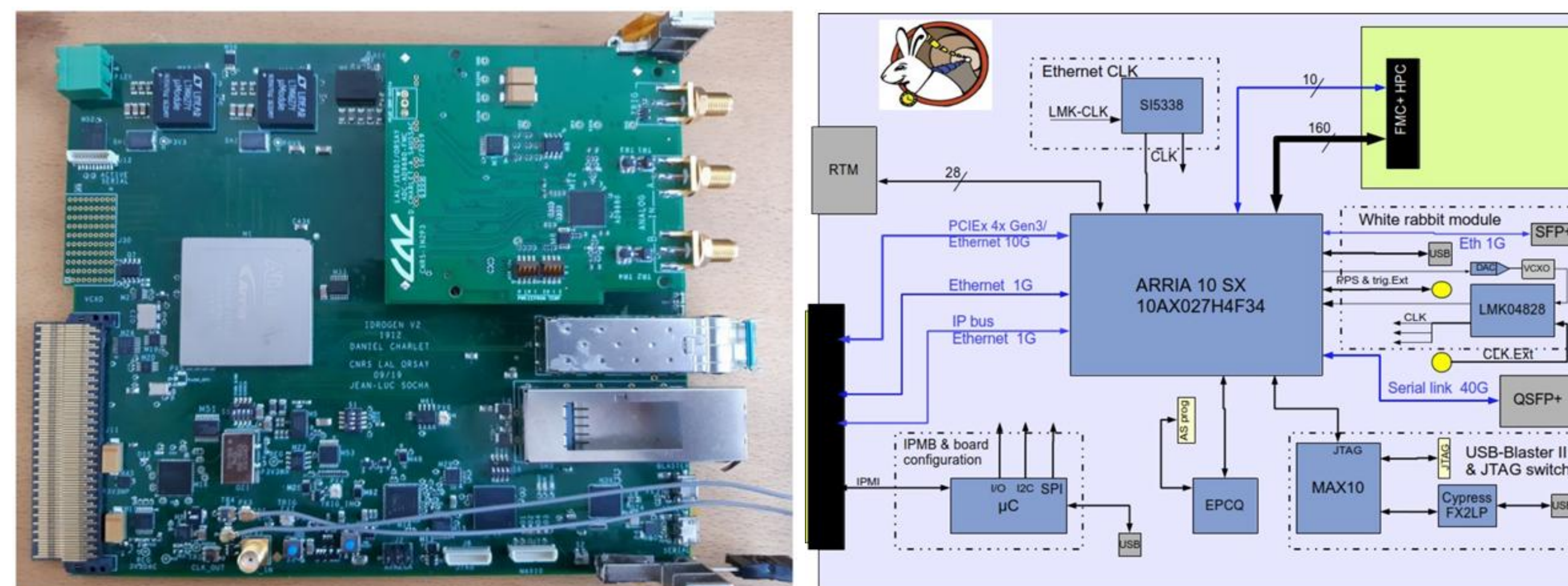

μTCA.4

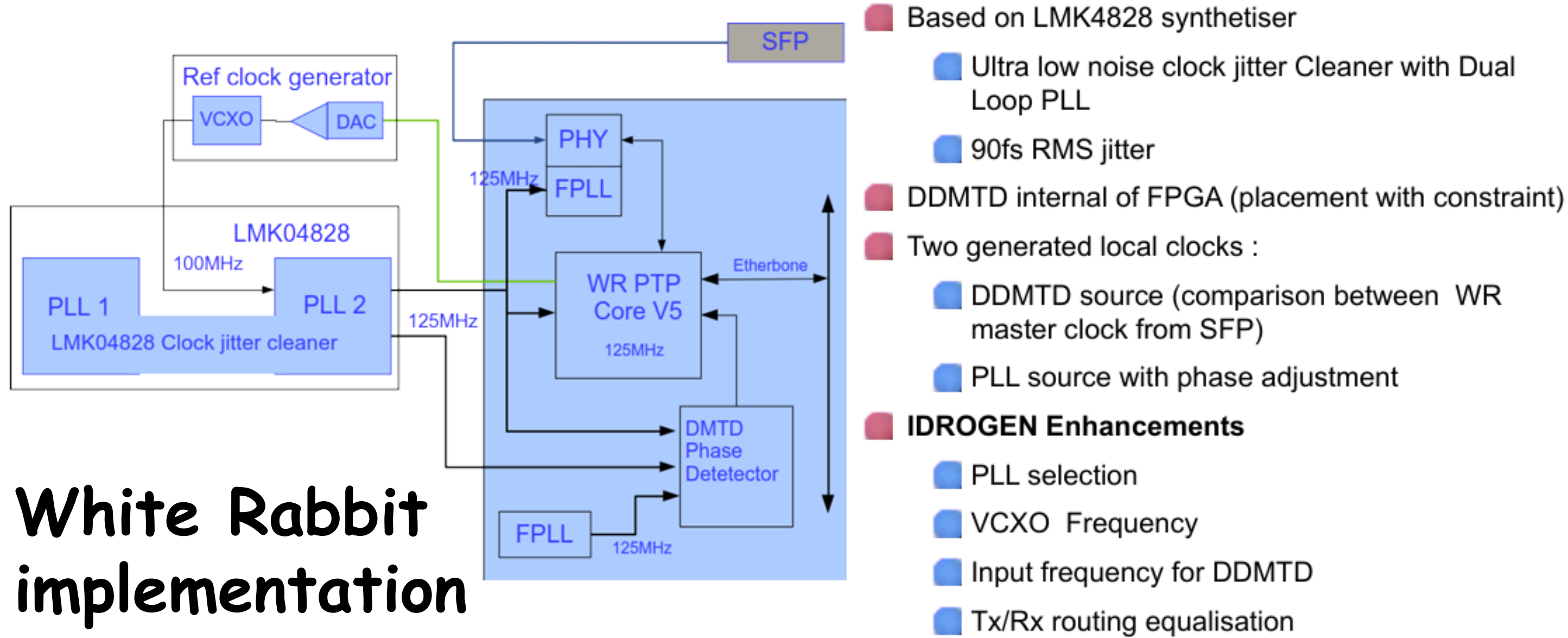

## White Rabbit implementation

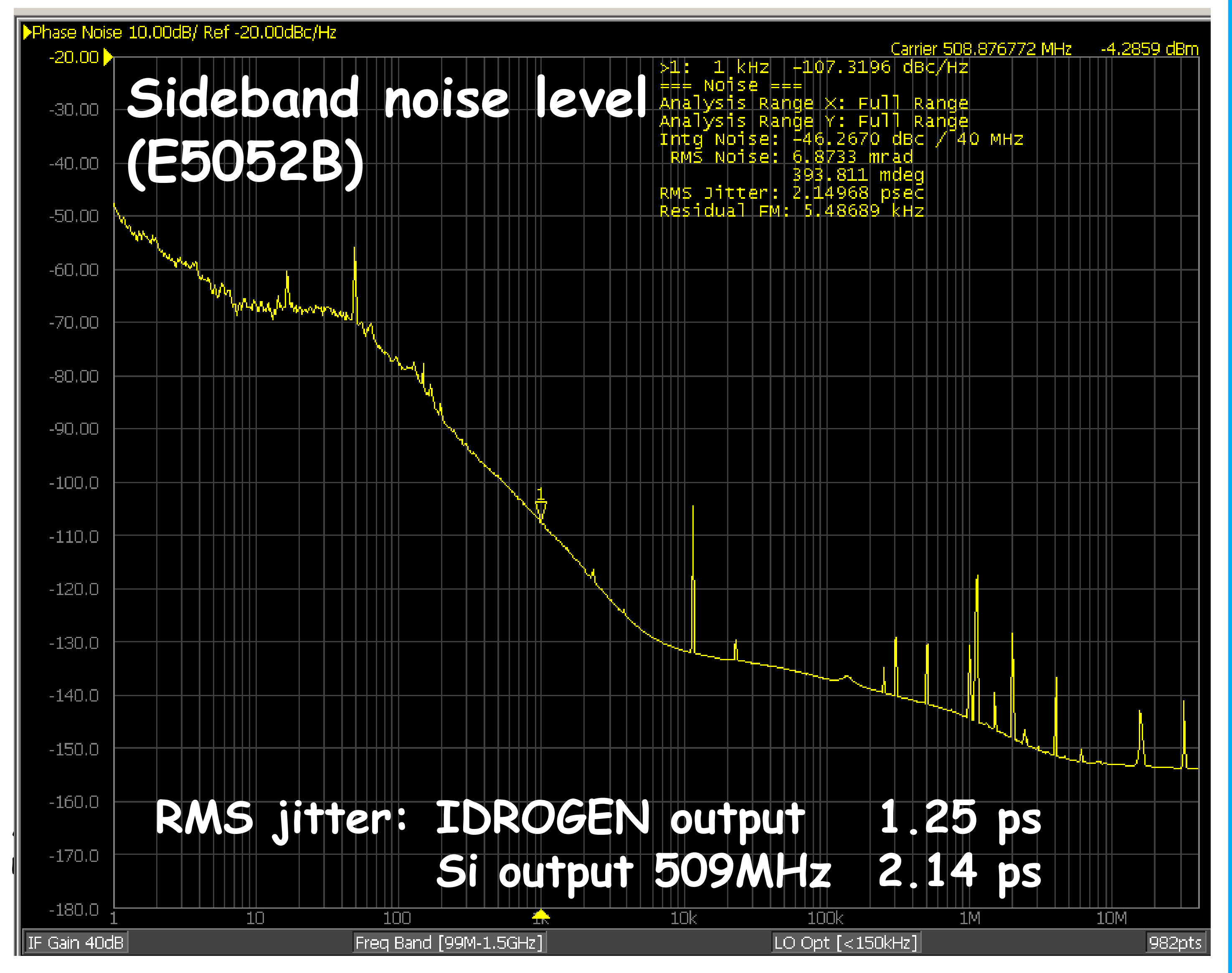

## Long-term stability of the relative phase under the drift SuperKEKB-509MHz

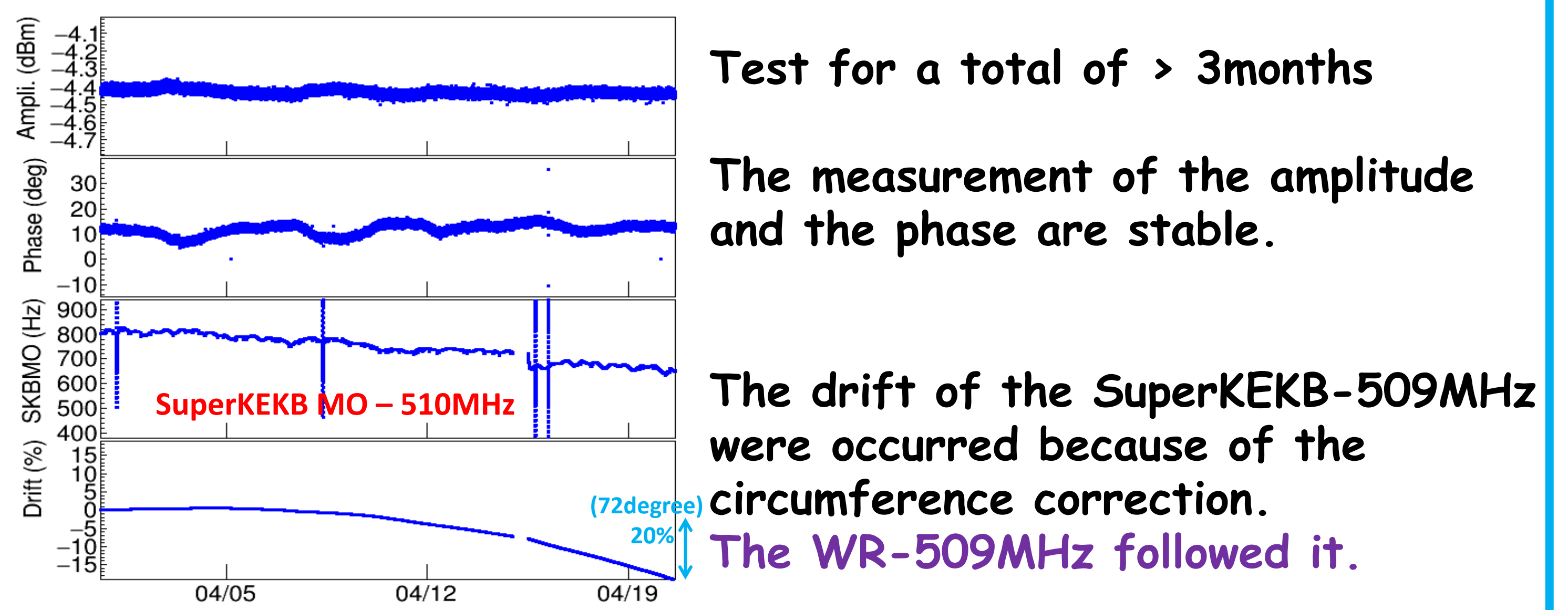

## SuperKEKB setup

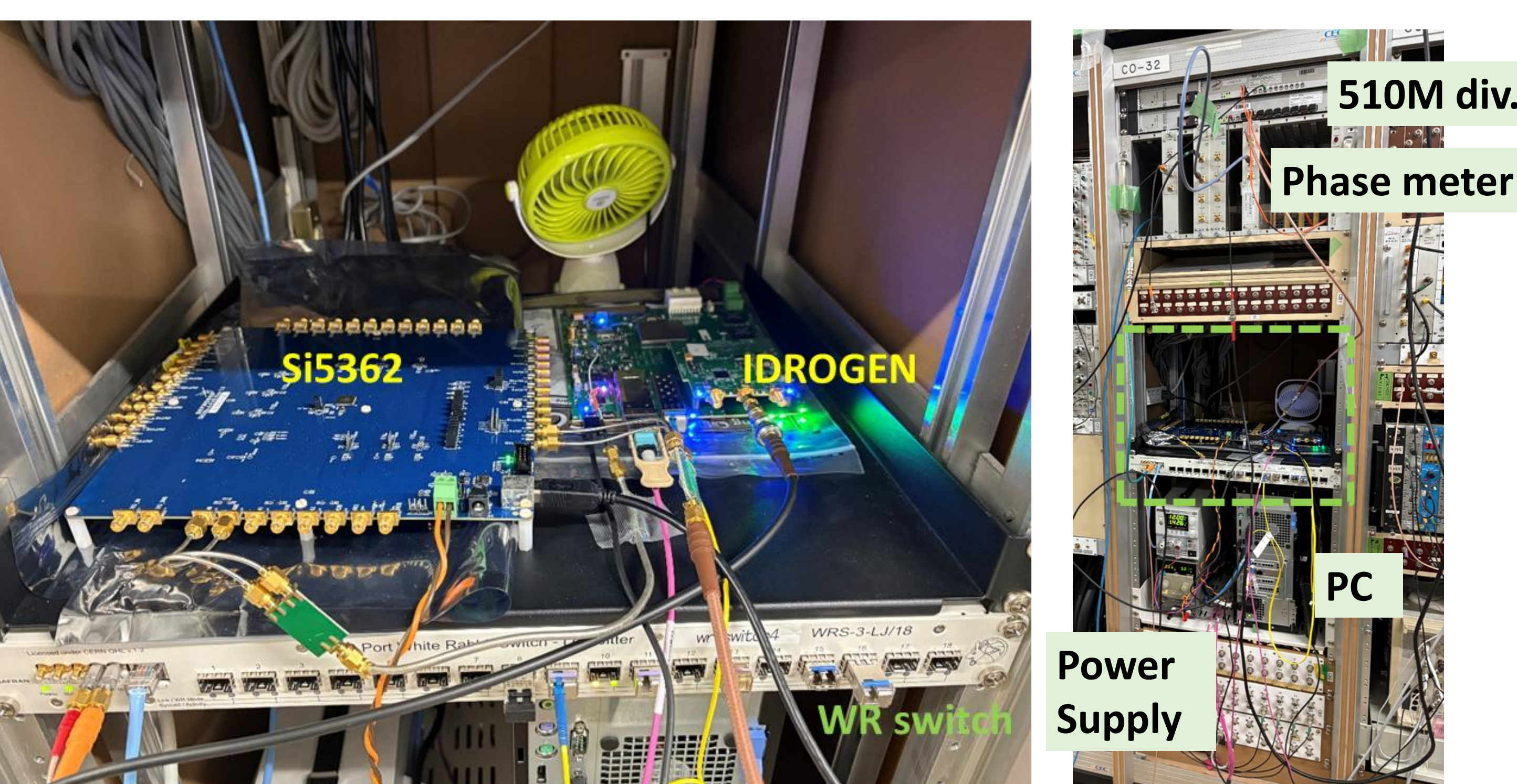
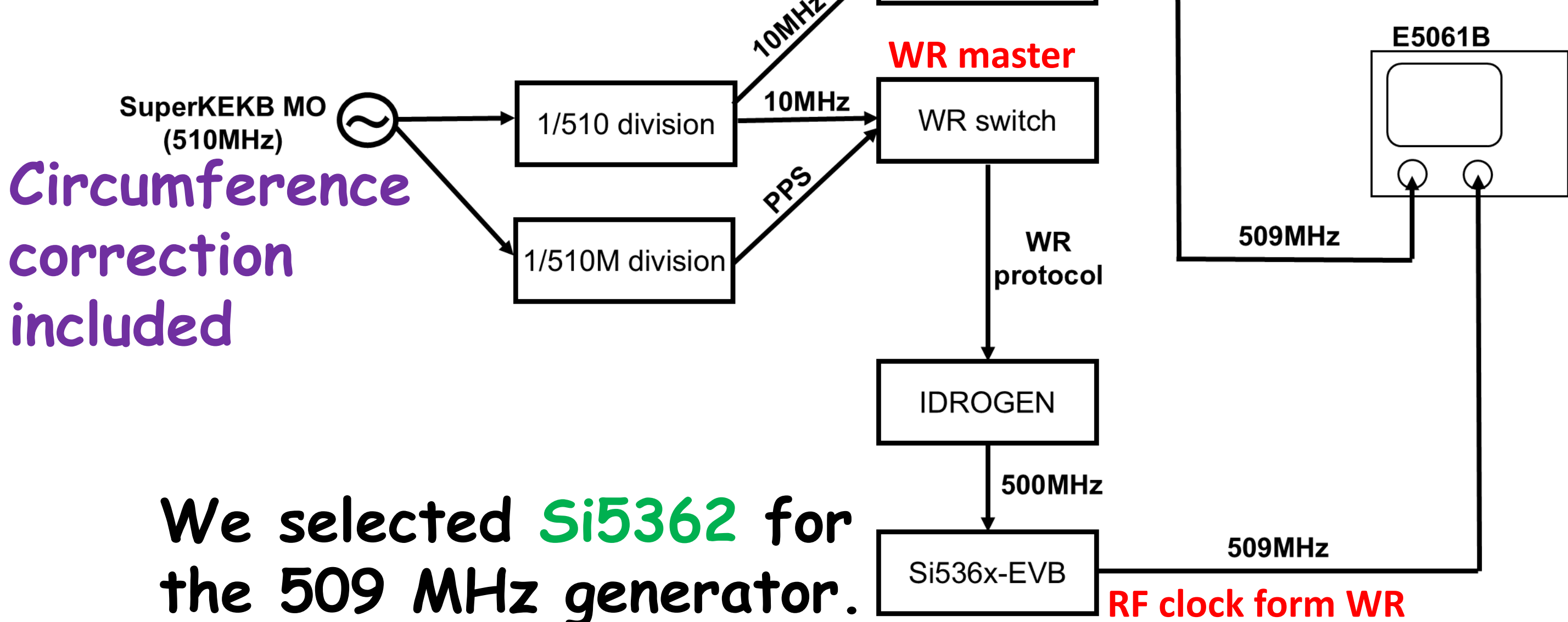

The phase drifts depending on the temperature and humidity are observed.

The correlation with the temperature is stronger. However, it is stabilized with the air conditioning. The humidity-drift is dominant in this measurement.

