

Searches for new physics using unconventional signatures and techniques with the ATLAS detector

S. V. Chekanov (ANL)

On behalf of the ATLAS collaboration

PASCOS 2026, Sheffield, UK, June 22 - 26, 2026

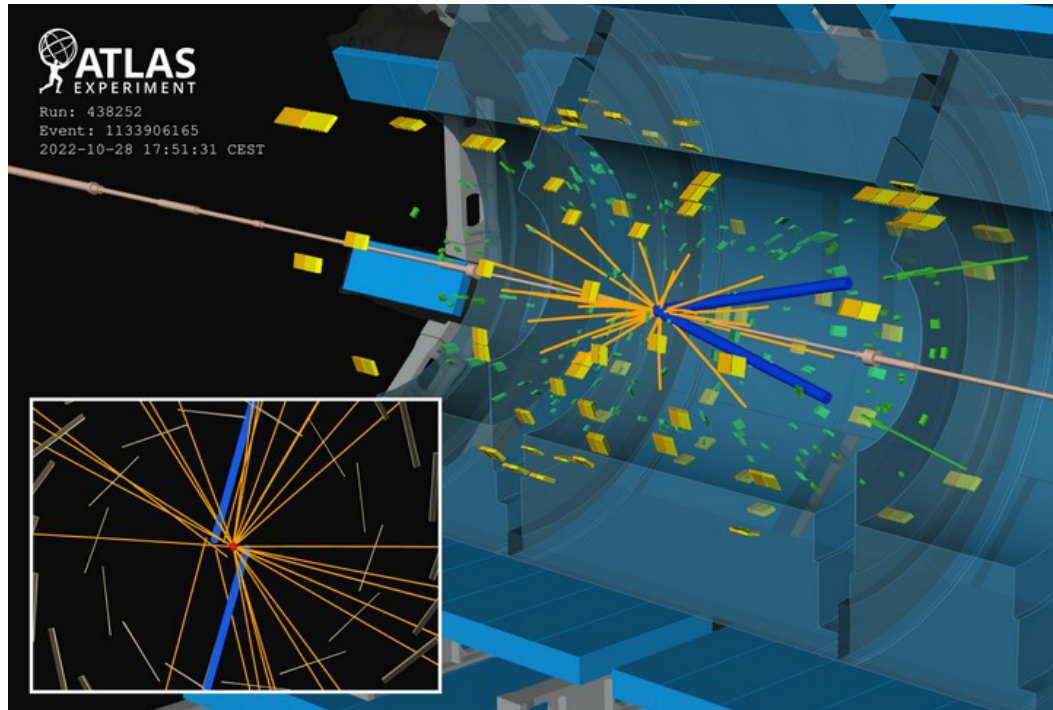

Collision event recorded by the ATLAS detector at an energy of 13.6 TeV, featuring two candidate displaced electrons

LHC Large Hadron Collider

the world's highest-energy particle accelerator

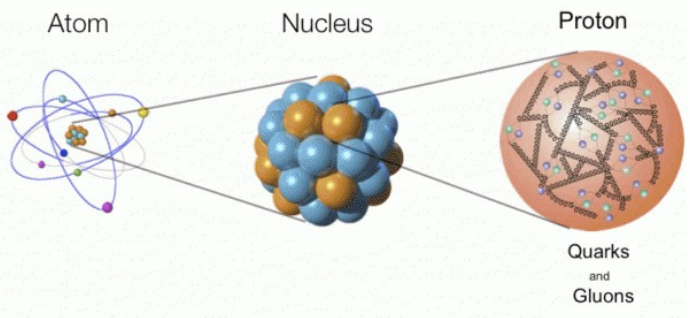

- Protons accelerated to ~13 TeV (Run2) – 13.6 TeV (Run3)
- Kinetic energy is transformed into matter at the collision

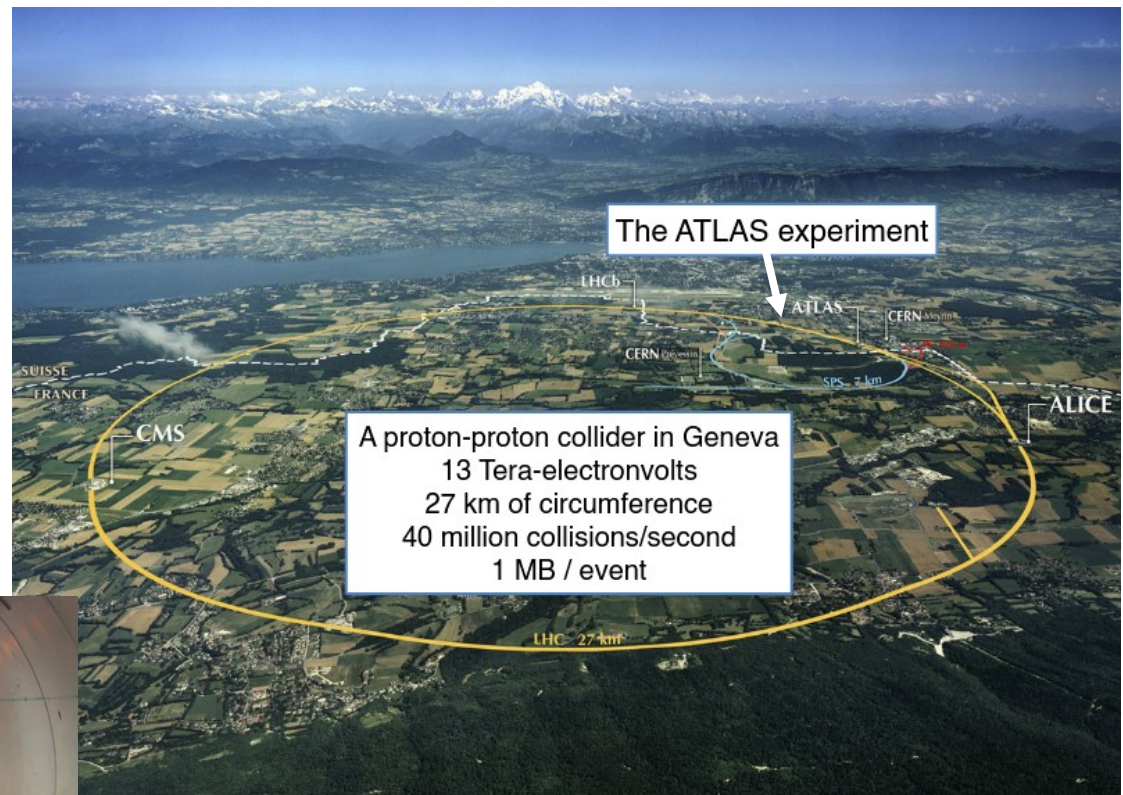
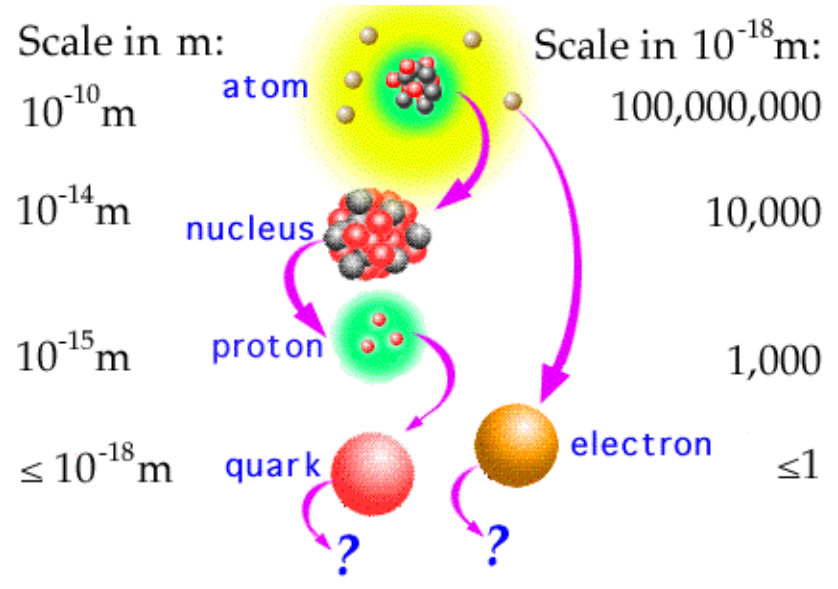

Many open questions

- What is the origin of the Higgs?
- What is the origin of dark matter and dark energy?
- Matter and almost no antimatter
- What is the origin of ~20 free parameters of Standard Model?
- What is origin of fine tuning in the Standard Model?

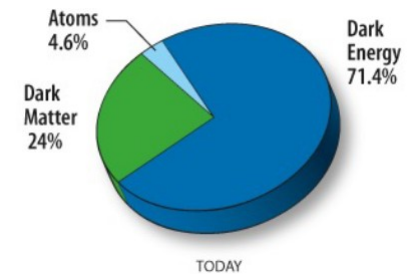

Example:

Higgs mass is a measured parameter, but its mass should be very large if we calculate it from a theory with large contributions from quadratic divergences due to radiative corrections.

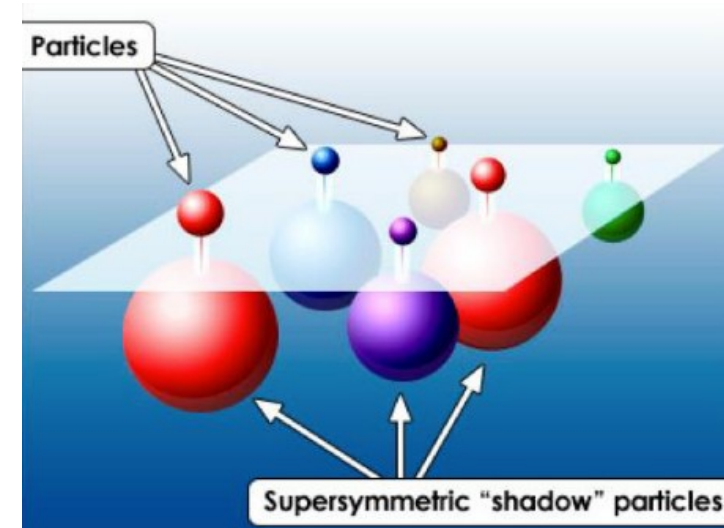
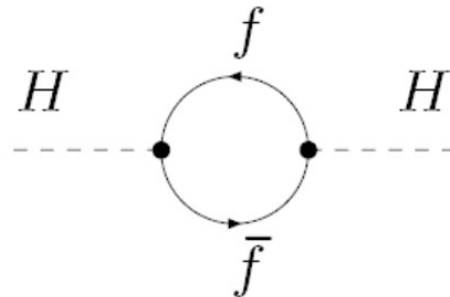

In order for the Higgs boson mass to be finite, a fine tuning (cancellation) of various loops is required ("hierarchy problem"). **New particles** can cancel such divergencies and will lead to the finite 125 GeV mass

LHC status: Run2 and Run3

Higgs discovery

We are here

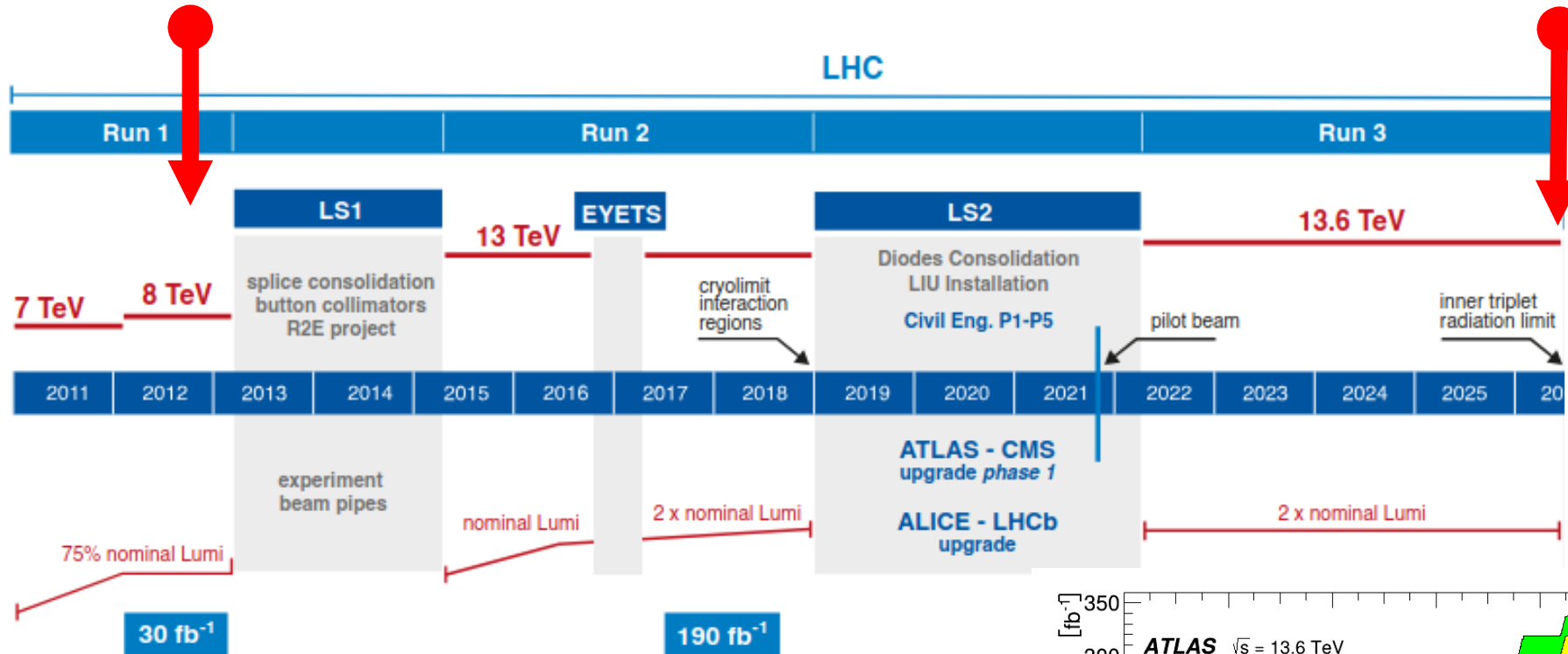

LHC pp collision timeline:

- Run1: 2011 – 2012 - 7 & 8 TeV collisions
- Run2: 2015 – 2018 - 13 TeV collision
- Run3: 2022 - 2026 - 13.6 TeV collisions

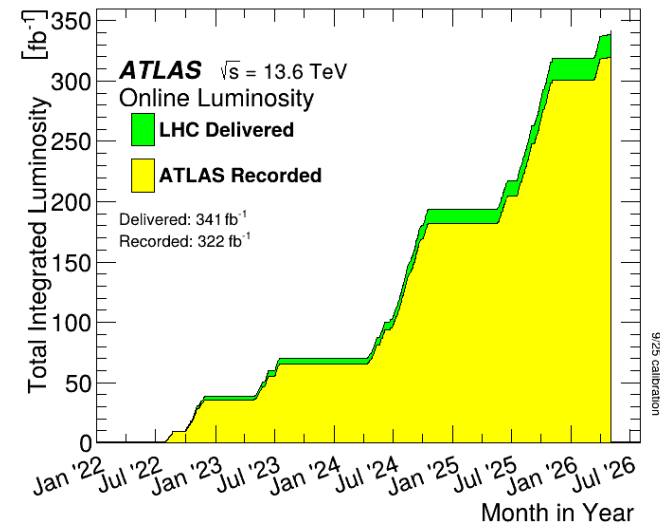

ATLAS detector for Run3

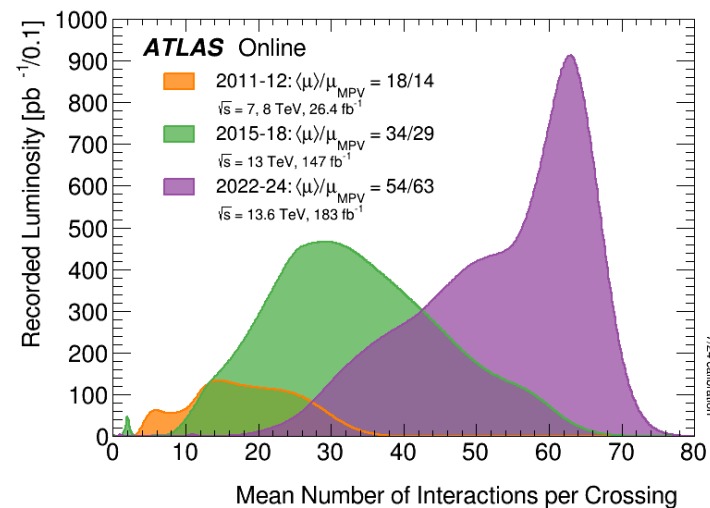
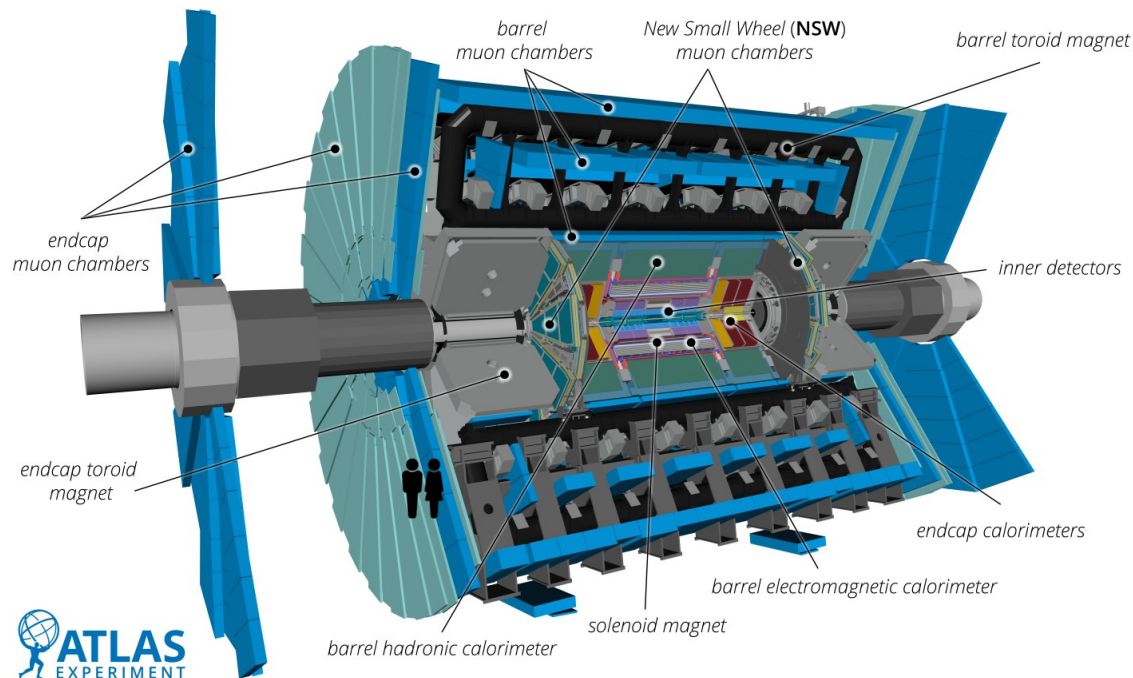

LHC had $\mu=63$ for Run3
(x2 larger than for Run2)

Changes in performance for Run3

- ▶ Muon New Small Wheel system included in data resulted in increased efficiency for muons
- ▶ Calorimeter timing information to reject contributions from pileup to topoclusters jets
- ▶ Machine-Learning (ML) entering all stages of the reconstruction
- ▶ Improved flavor tagging using ML (“GN2”)
- ▶ Improved trigger menus to address larger pileup, etc.

ATLAS searches for new particles

ATLAS Heavy Particle Searches* - 95% CL Upper Exclusion Limits

Status: Spring 2026

ATLAS Preliminary

$$\int \mathcal{L} dt = (3.6 - 195) \text{ fb}^{-1} \quad \sqrt{s} = 13, 13.6 \text{ TeV}$$

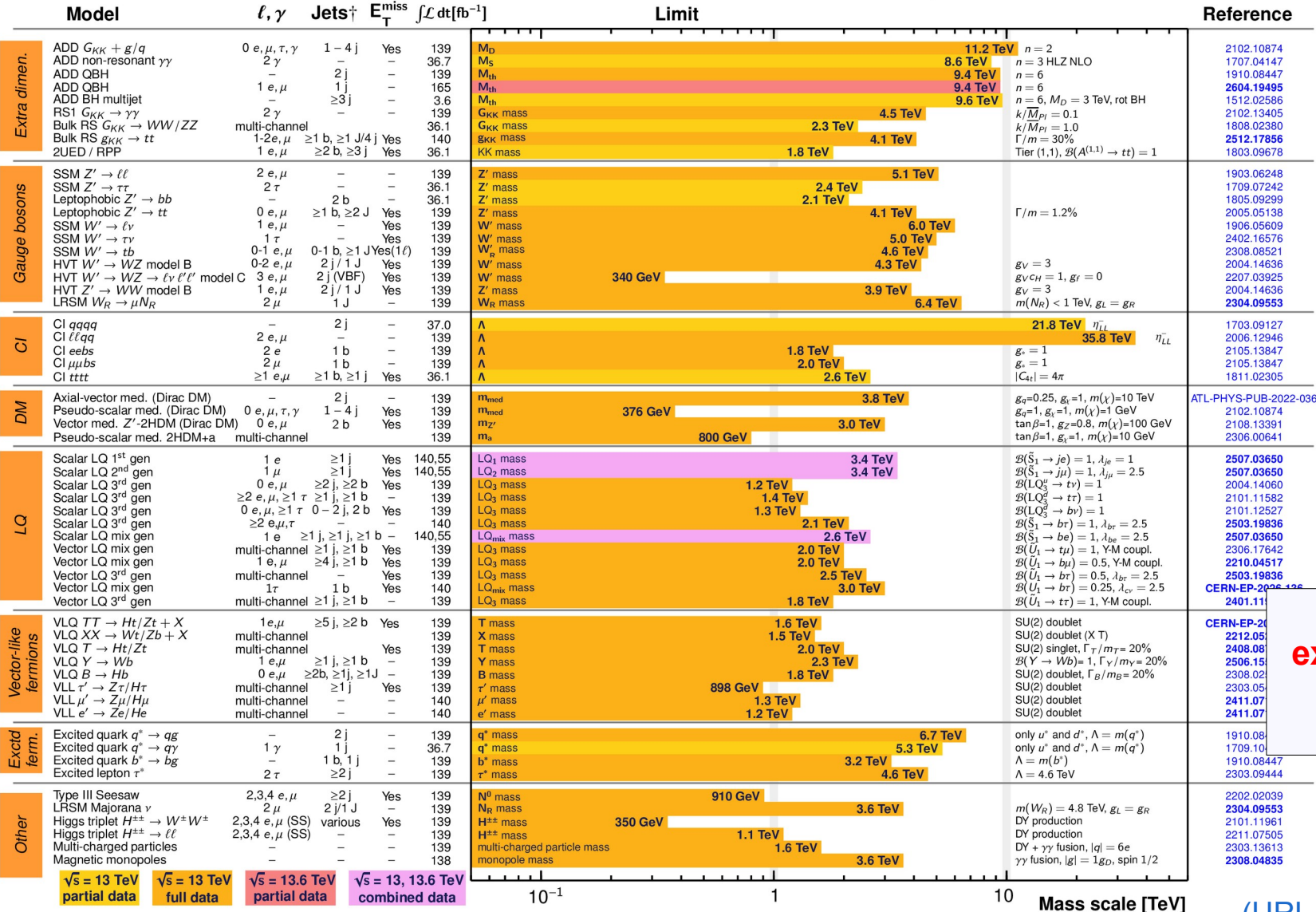

ATL-PHYS-PUB-2026-004

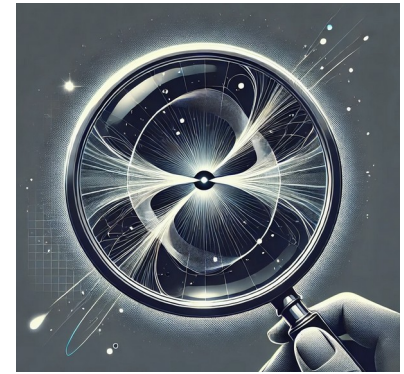

Heavy particles excluded up to 12 TeV mass for ~50 BSM models

*Only a selection of the available mass limits on new states or phenomena is shown.

† Small-radius (large-radius) jets are denoted by the letter j (J).

(URL to the Summary plots)

New physics at collider experiments

Standard Model of Elementary Particles

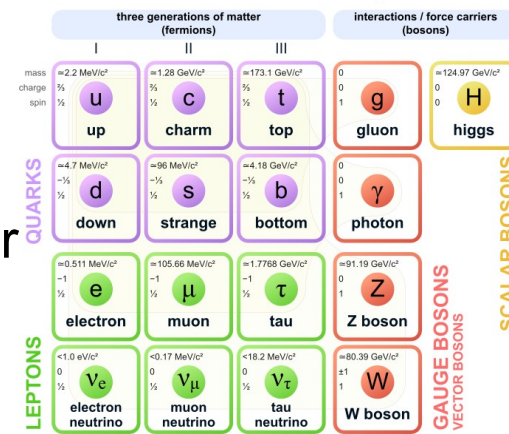

- Standard Model (SM) is successful for particle collisions
- Discrepancies may indicate new physics ≡ new particles/fields

Direct searches for new particles:

- Model-dependent*: Use BSM model and optimize selection for “signal” regions defined in terms of standard kinematics
- Model-independent*: Combine known particles/jets to create “invariant masses” & search for excesses

New physics could be richer than typical BSM models or just invariant masses, and addressing this possibility requires searches based on unconventional signatures.

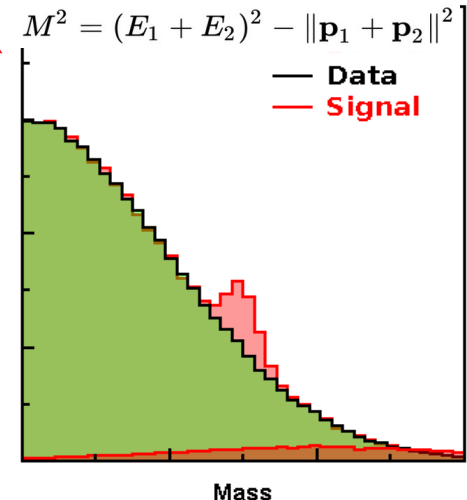

Invariant mass from known particle/jet with energy E and p

Unconventional (“unusual signatures”):

Displaced from the interaction point, muon-isolated objects (usually leptons, photons), anomalous in timing or kinematics, disappearing tracks or jets, anomaly detection, etc..

Missing-mass search in forward-proton-tagged dilepton events

- Some BSM scenarios predict new invisible particles produced with a visible system
- Forward proton tagging offers *model-independent* reconstruction of invisible mass; full kinematic info from $\gamma\gamma \rightarrow$ ATLAS forward proton (AFP) spectrometer.
- Signature:** Missing energy when measuring outgoing proton energies in AFP, assuming pp as a coherent source of photons at low Q^2 (protons remain intact)
- Method using AFP:**
 - Silicon Tracker at each station, four planes of silicon pixel sensors
 - All housed in movable Roman Pots

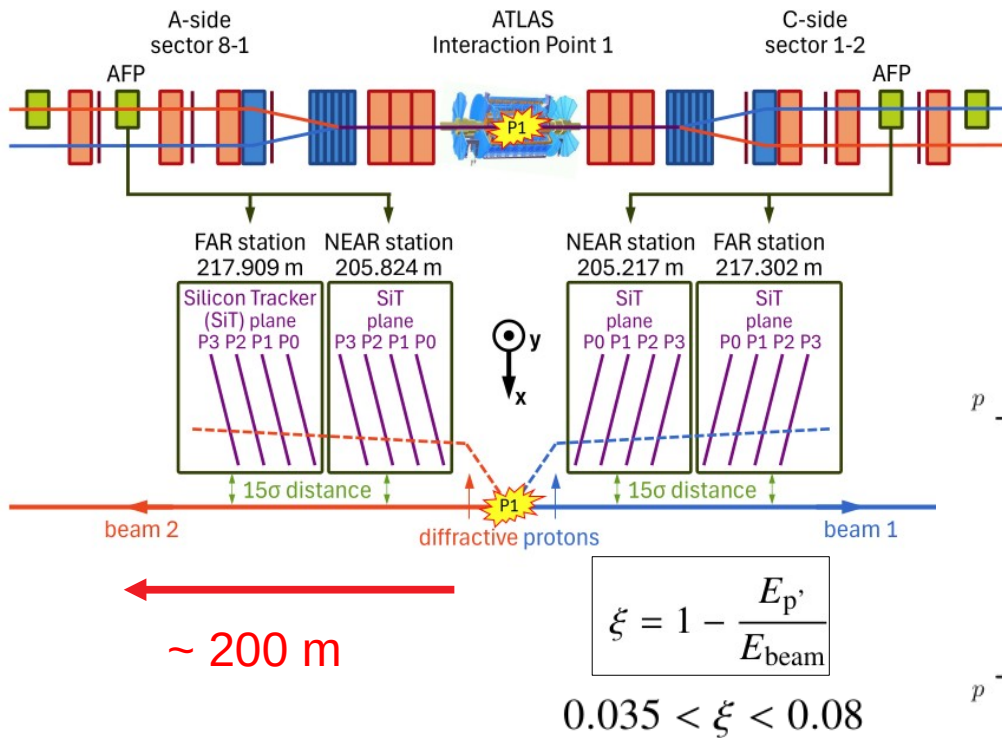

$$m_X^2 = (P_{\gamma\gamma} - P_{ll})^2$$

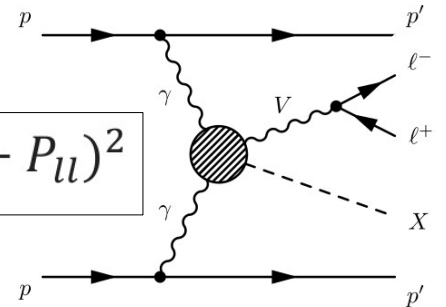

Example of BSM models:

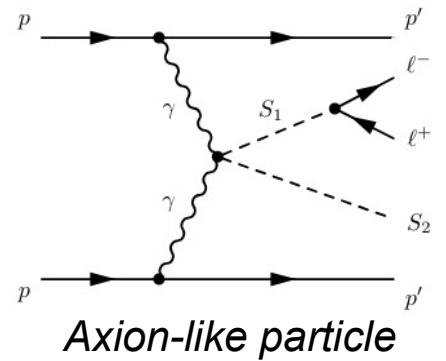
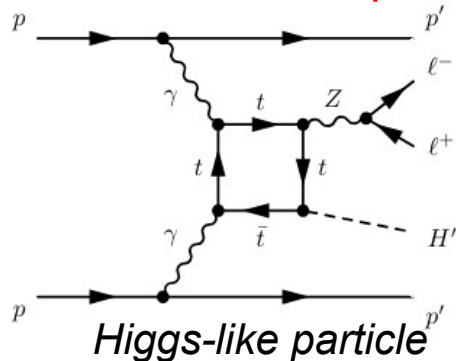

Missing-mass search in forward-proton-tagged dilepton events

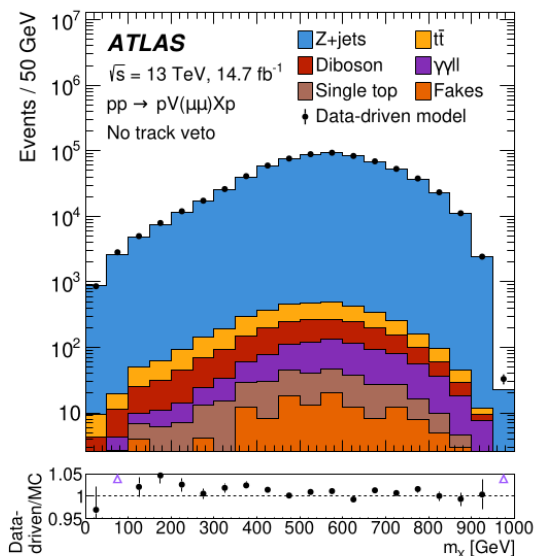

(a)

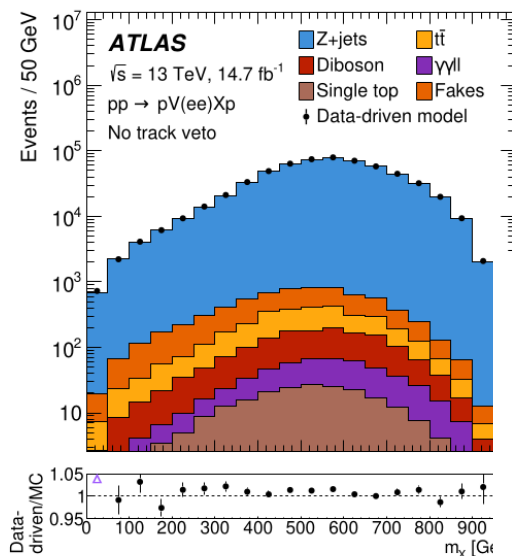

(b)

- Agreement with the SM background
- 95% CL upper limits on fiducial cross sections: $\sim 3 - 128$ fb (mass dependent)

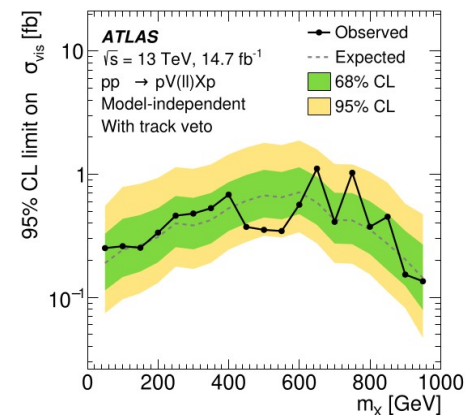
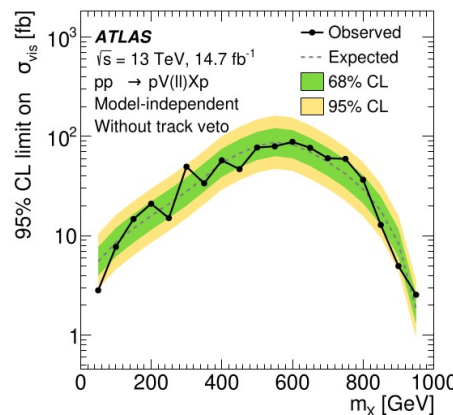

Limits on masses for specific models:

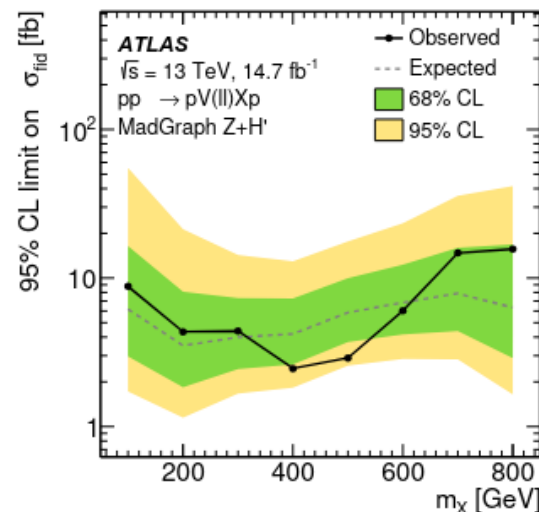
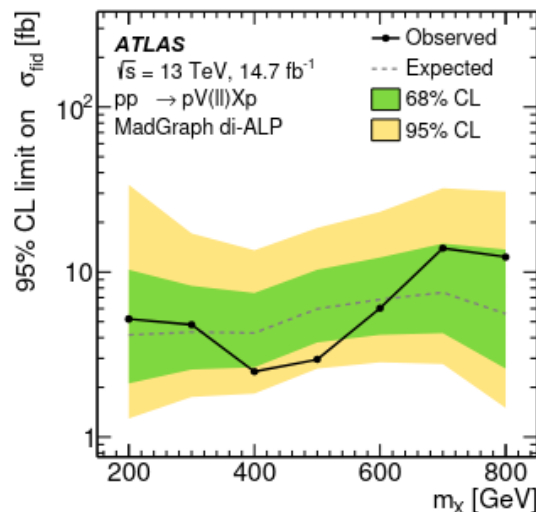
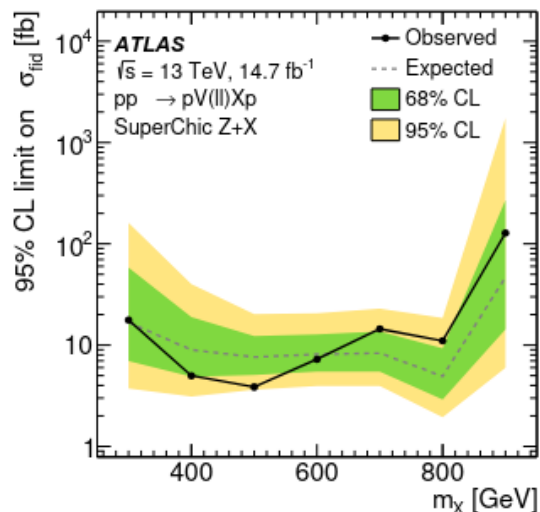

Search for soft unclustered energy patterns (SUEP) containing muons

arXiv:2605.20015

- Some extensions of SM (like Hidden Valley) predict emissions not dominated by soft and collinear splittings, and the resulting shower may instead populate phase space more uniformly
- Signature:** High-multiplicity, isotropic distributions of low-momentum particles in the CM frame

Example of BSM models:

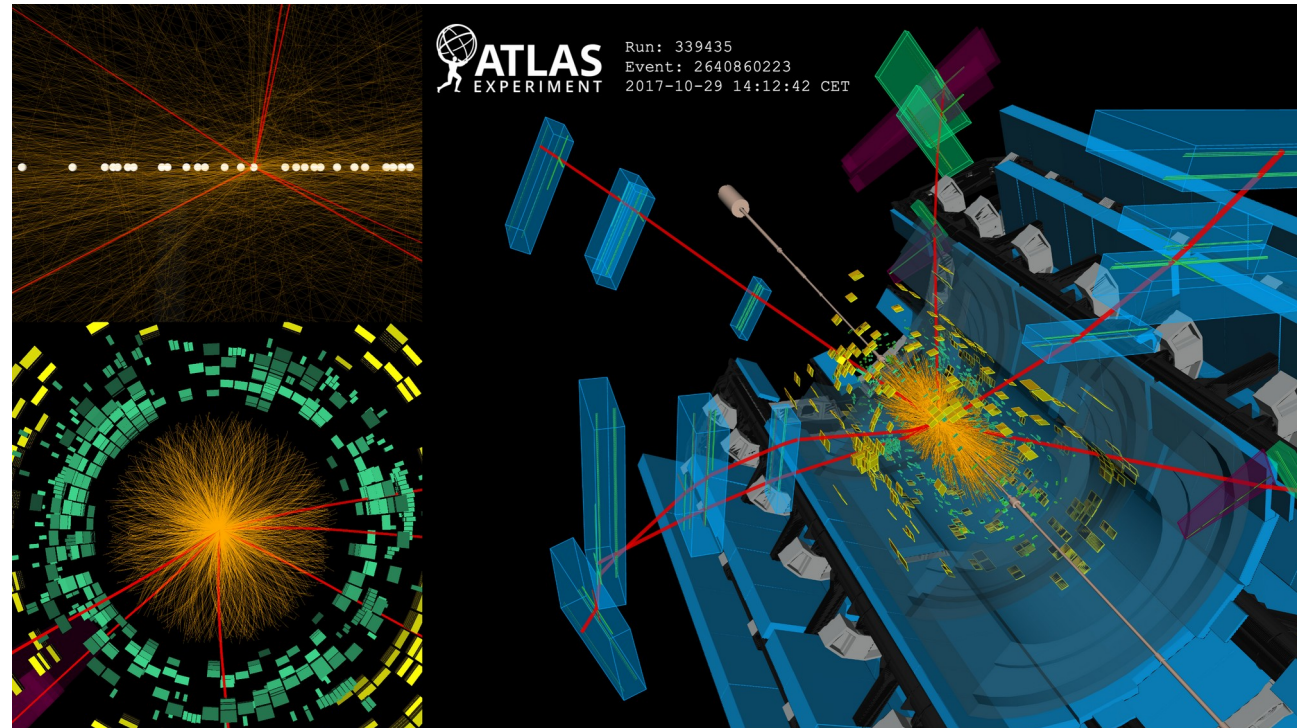
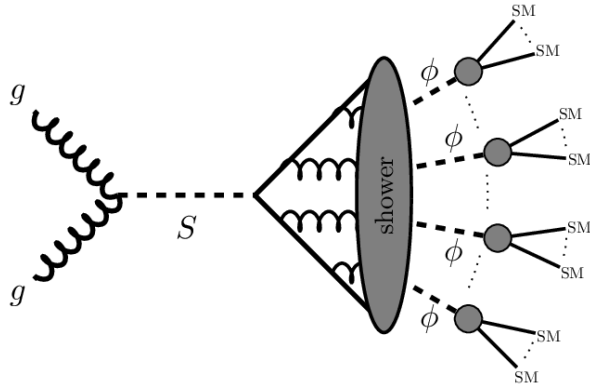

The mediator “S”:

- Higgs boson ($m=125$ GeV)
- Scalar particle with mass 400 or 750 GeV

Dark meson ϕ mass: 1.5 – 5 GeV

Search for unclustered energy patterns (SUEP) containing muons

- Background cannot be reliably estimated from Monte Carlo simulation
 → fully data driven background estimation method

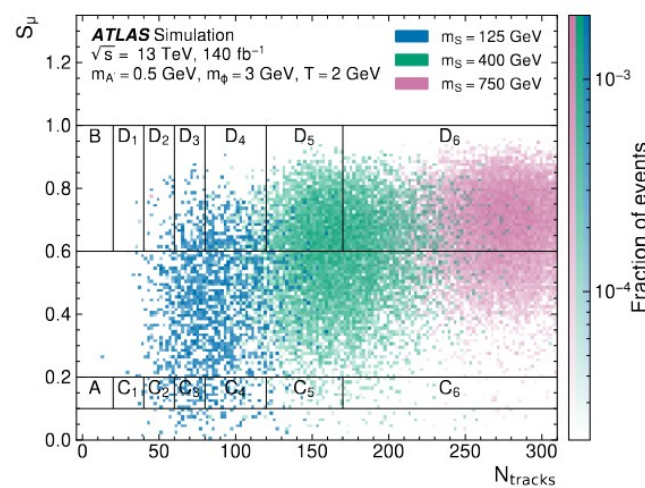
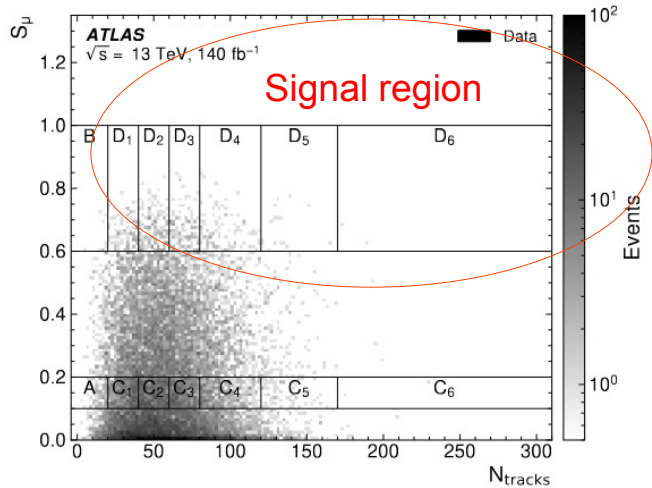

S_μ (Sphericity) used to quantify the geometry and spatial distribution of particles

$S_\mu \sim 1$ for isotropic events

- No deviation from SM prediction

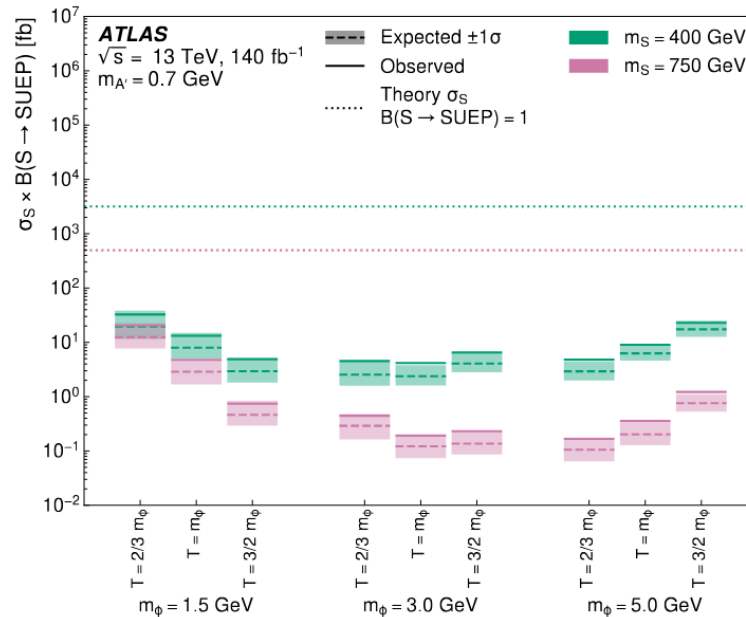
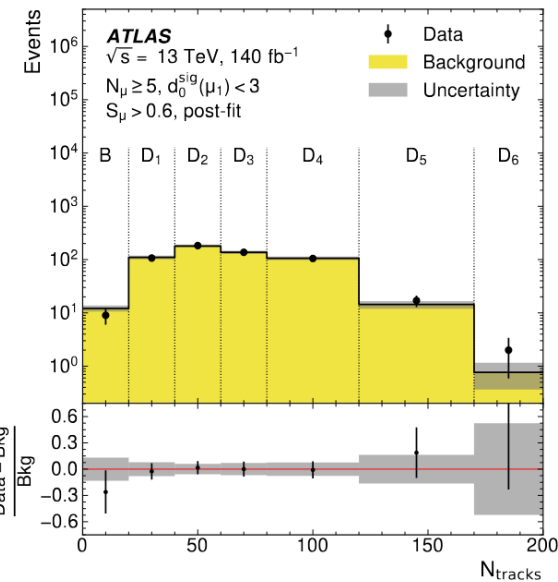

- Limits are set on theoretical predictions for different masses and temperatures T

- Complementary to studies reported by CMS for similar models in [PRL. 133 \(2024\) 191902](#)

Long lived particles (LLP)

Signatures: Displaced tracks, secondary vertices, large transverse impact parameters, delayed calorimeter deposits, delayed track hits, abnormal time-of-flight

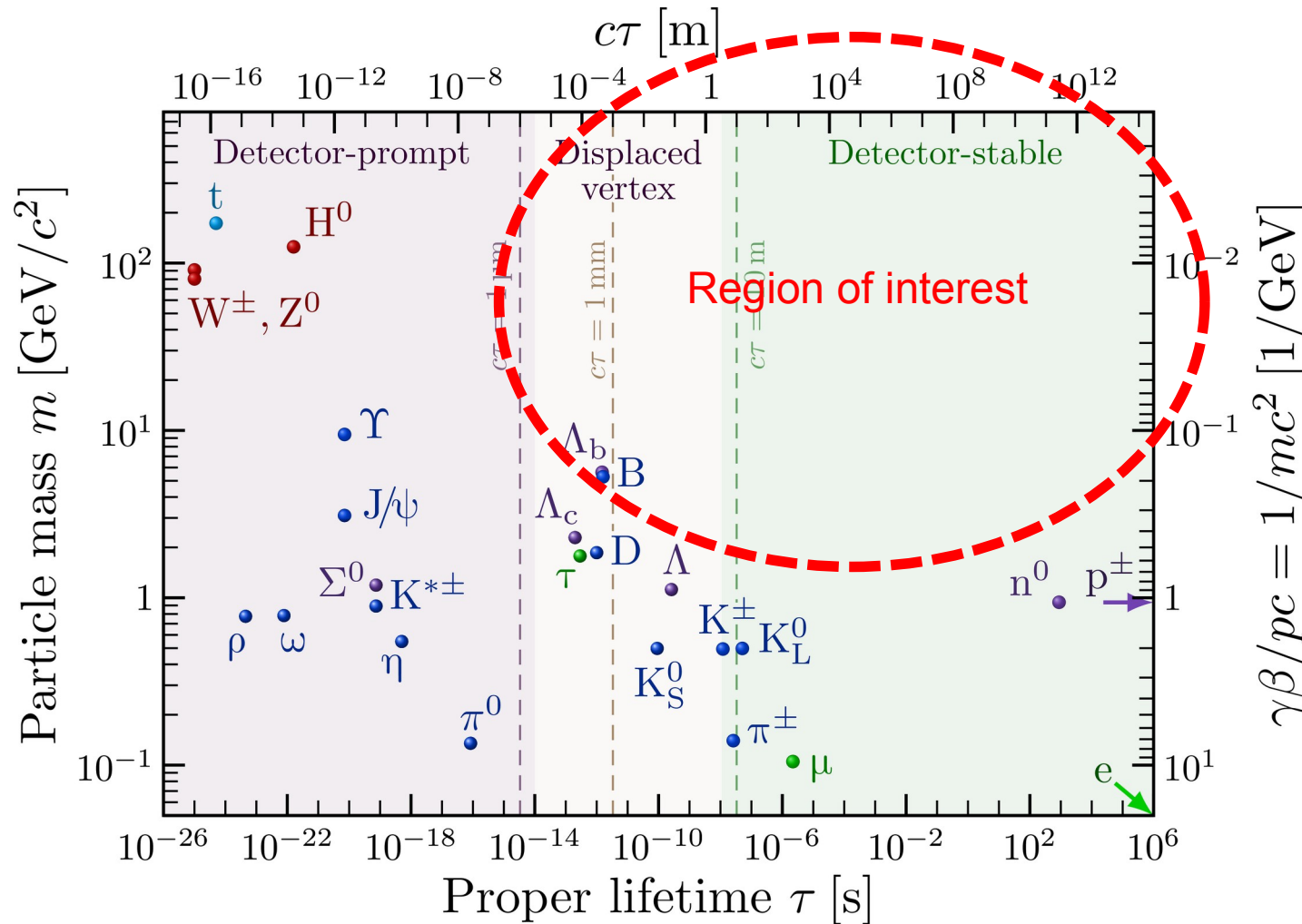

Lifetime

$$\tau^{-1} = \Gamma \sim y^2 \left(\frac{m}{\Lambda} \right)^n \Phi$$

Used to solve the hierarchy problem, dark matter, etc. via models such as:

- Heavy Neutral Leptons
- Higgs portal
- Supersymmetry

Credits to I. Neutelings https://tikz.net/sm_particles_masses/

Search for higgsinos in compressed mass spectra using low-momentum tracks

- Search motivated by SUSY - a leading candidate of physics beyond the SM (gauge coupling unification, addresses the fine-tuning problem of the Higgs boson)
- Highly compressed scenarios $\Delta m(\tilde{\chi}_1^\pm, \tilde{\chi}_1^0) \lesssim 300\text{--}400\text{ MeV}$
- Signature:** an energetic jet, large missing transverse momentum, and at least one low-momentum charged particle that serves as a candidate higgsino decay product.

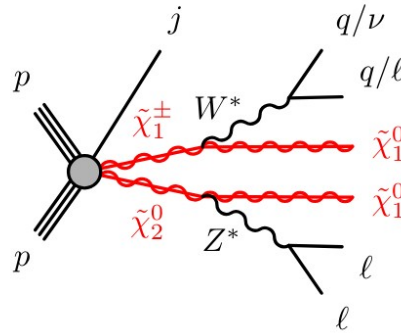
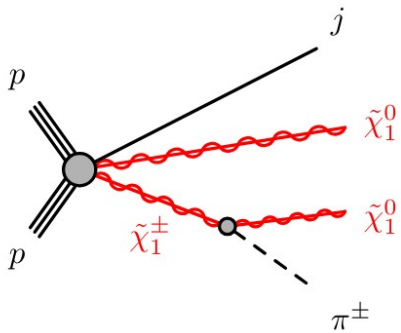

$\tilde{\chi}_1^\pm$ } traverses several silicon layers of the inner detector before decaying into an invisible neutralino a soft tracks (or 2 hard leptons)

Small Δm (<1 GeV)
low- p_T π^+ with large transverse impact parameters due to the long higgsino lifetime

Large Δm (~5 GeV)
Higgsinos are expected to decay promptly into low-momentum leptons

Gains from ML techniques is equivalent of $\geq 60\%$ increase in luminosity

$O(0.1\text{--}1\text{ mm})$

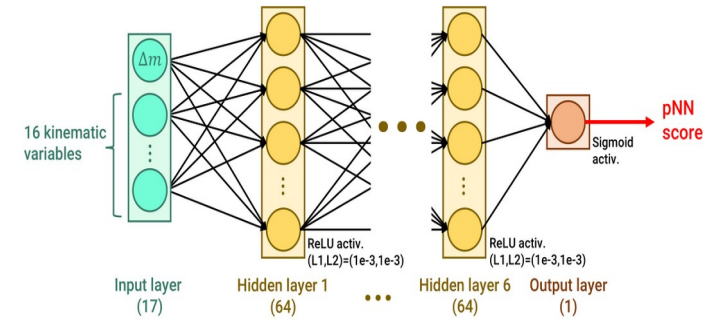
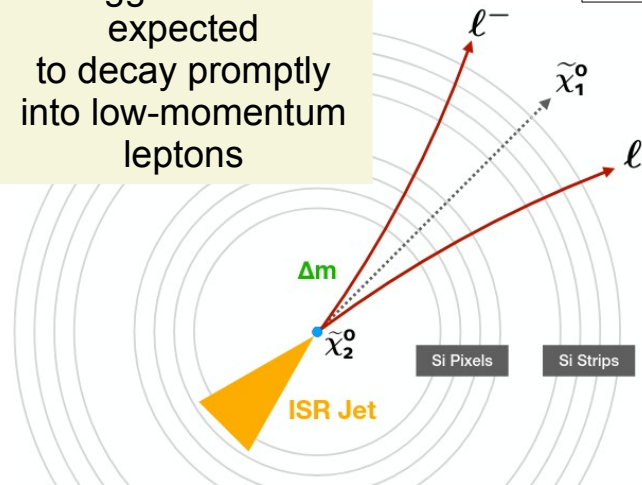
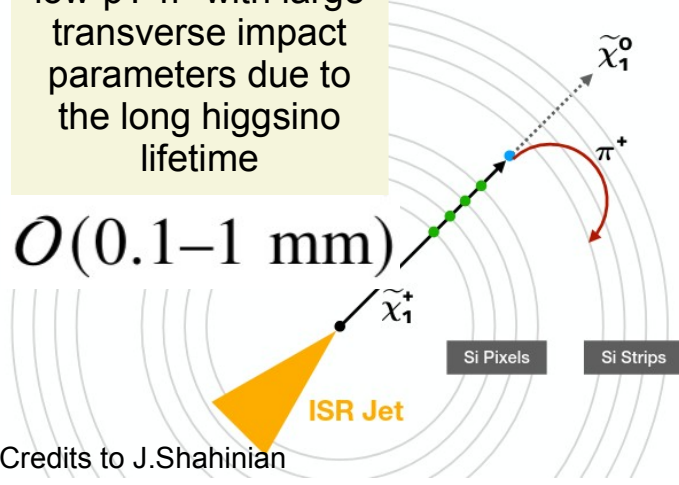

ML utilities tracking and calorimeter information.

Credits to J.Shahinian

Search for higgsinos in compressed mass spectra using low-momentum tracks

Extending the limits established by the LEP experiments up to $m(\tilde{\chi}_1^\pm) = 132$ GeV for $\Delta m(\tilde{\chi}_1^\pm, \tilde{\chi}_1^0) = 1.8$ GeV

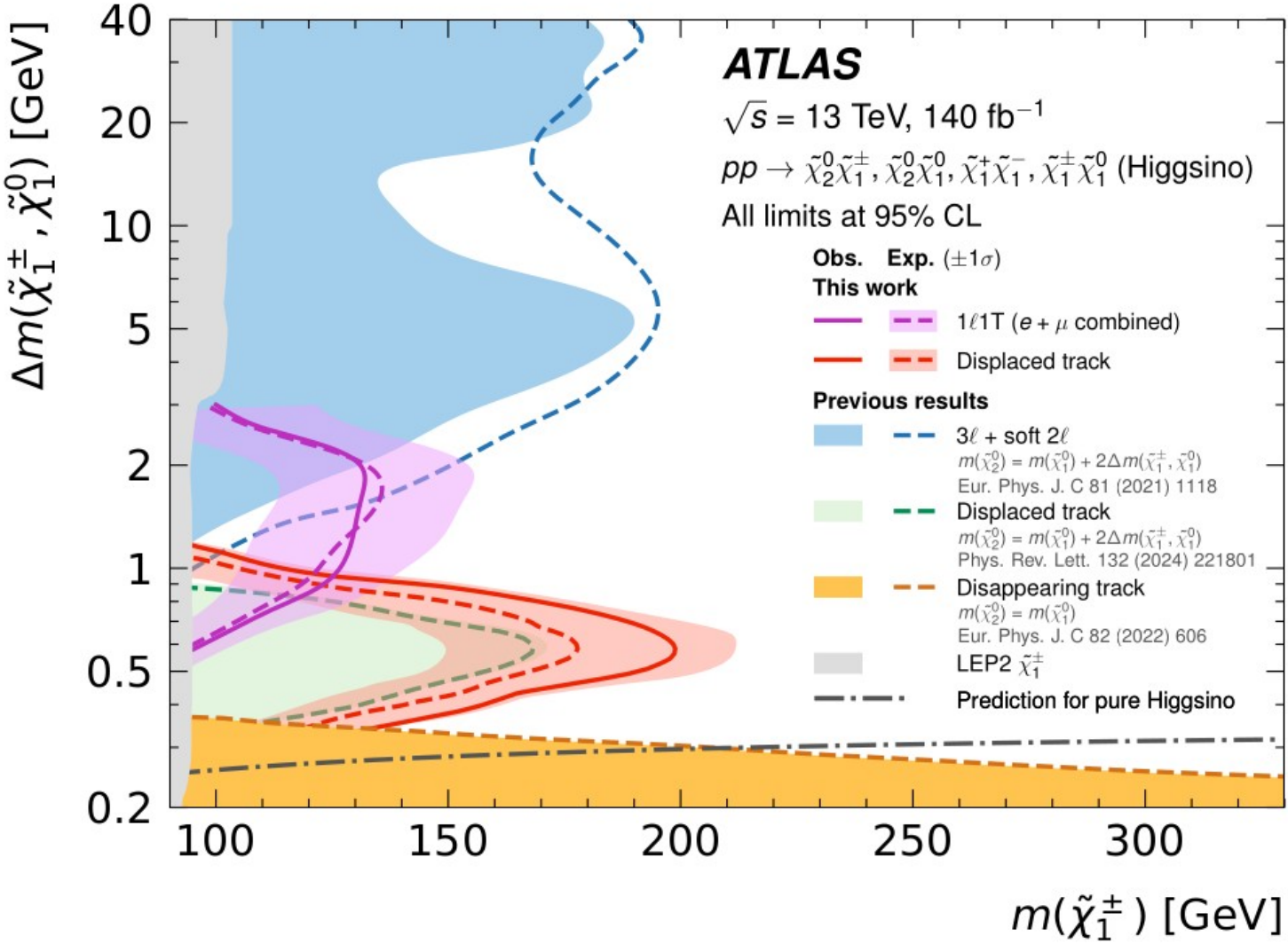

Search for massive LLP in association with a muon

- Many extensions of the SM (SUSY models + R -parity violating, Stealth SUSY, neutral naturalness, hidden valley models) predict heavy LLP associated with leptons
- Signature:** at least one displaced vertex and at least one displaced muon

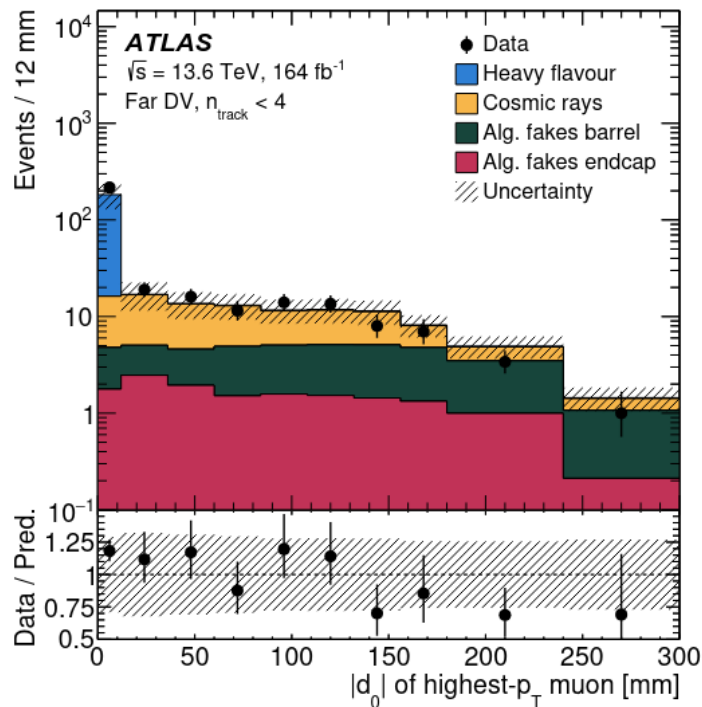

The largest background
 – cosmic rays

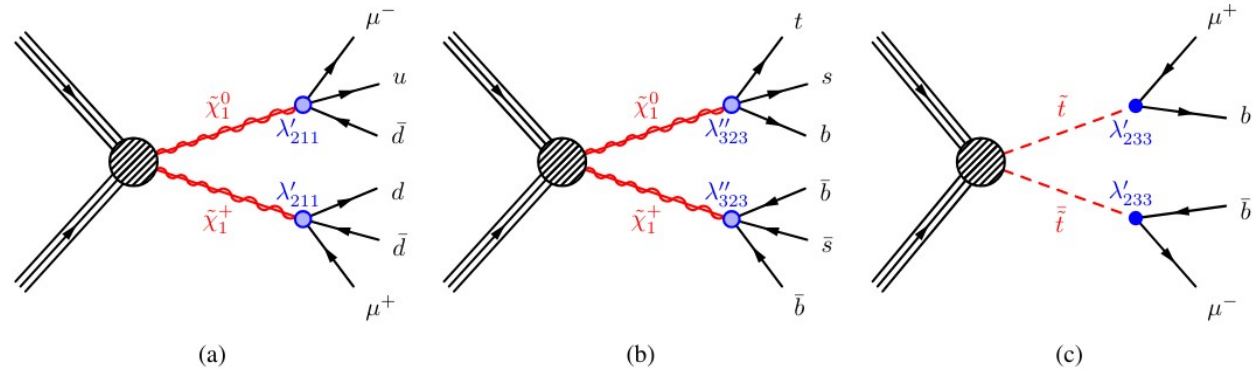

- Use transverse impact parameter (d_0) relative to the interaction point (IP) to reconstruct displaced vertices
- At least four associated tracks with displaced vertex
- Displaced-muon trigger selects events containing at least one muon candidate reconstructed in the with $p_T > 20 \text{ GeV}$, $|\eta| < 2.4$, and $|d_0| > 2 \text{ mm}$

Search for massive LLP in association with a muon

3 benchmark models: higgsino pair production with
 (a) λ'_{211} -violating $\tilde{\chi}_1^0$ decays (b) λ''_{323} -violating $\tilde{\chi}_1^0$ decays (c) $\tilde{t}\tilde{t}$ production with λ'_{233} -violating \tilde{t} decays.

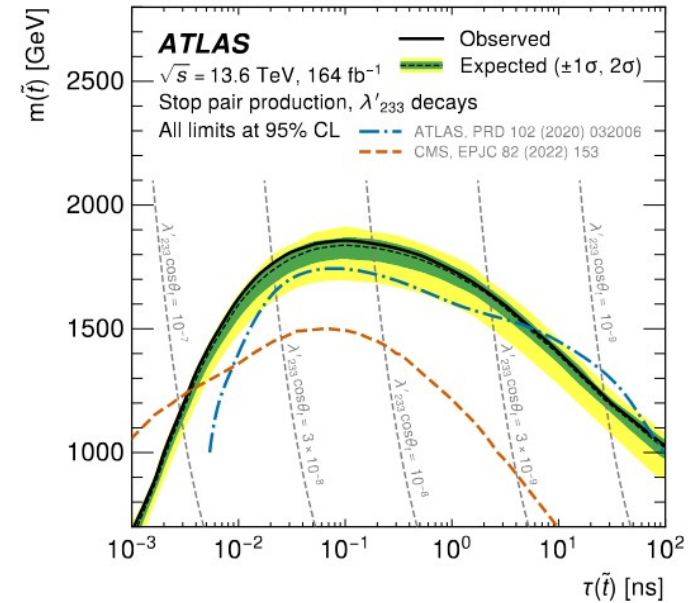
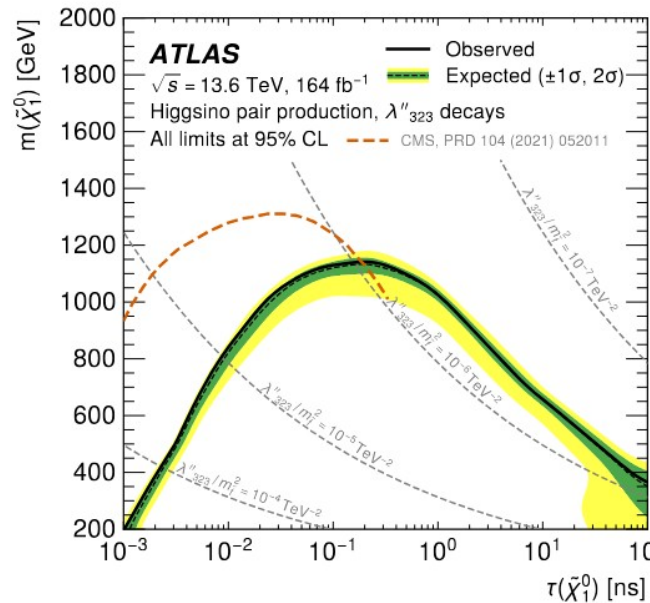
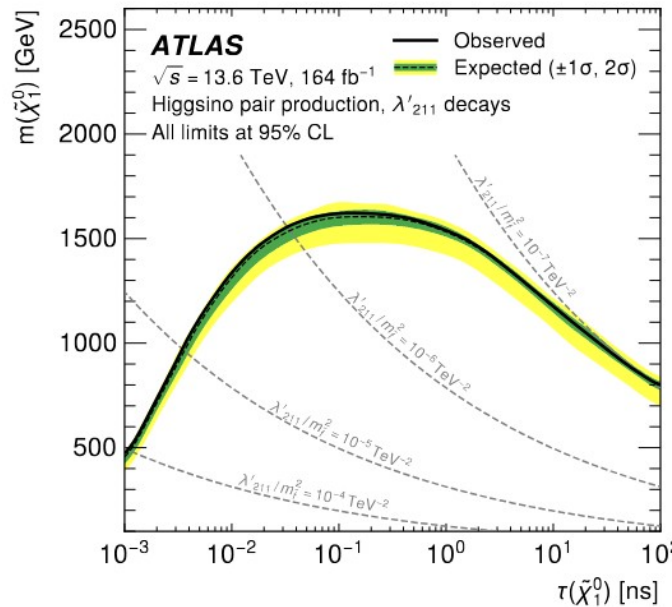

- Model-independent 95% CL upper limits on the visible cross-section, σ , for final states containing at least one displaced vertex and at least one displaced muon
- Also shown are contours of the R -parity-violating (RPV) SUSY coupling strength

- LLP yield a variety of experimental signatures motivated by SUSY and other models:
- Signatures:** massive, identifiable displaced vertex that involve multiple outgoing charged particles + significant missing transverse momentum
- Using novel ML-optimized “fuzzy” vertexing for identifying displaced heavy quarks - displaced heavy-flavor decays as an extended region of track origins rather than a single point-like vertex

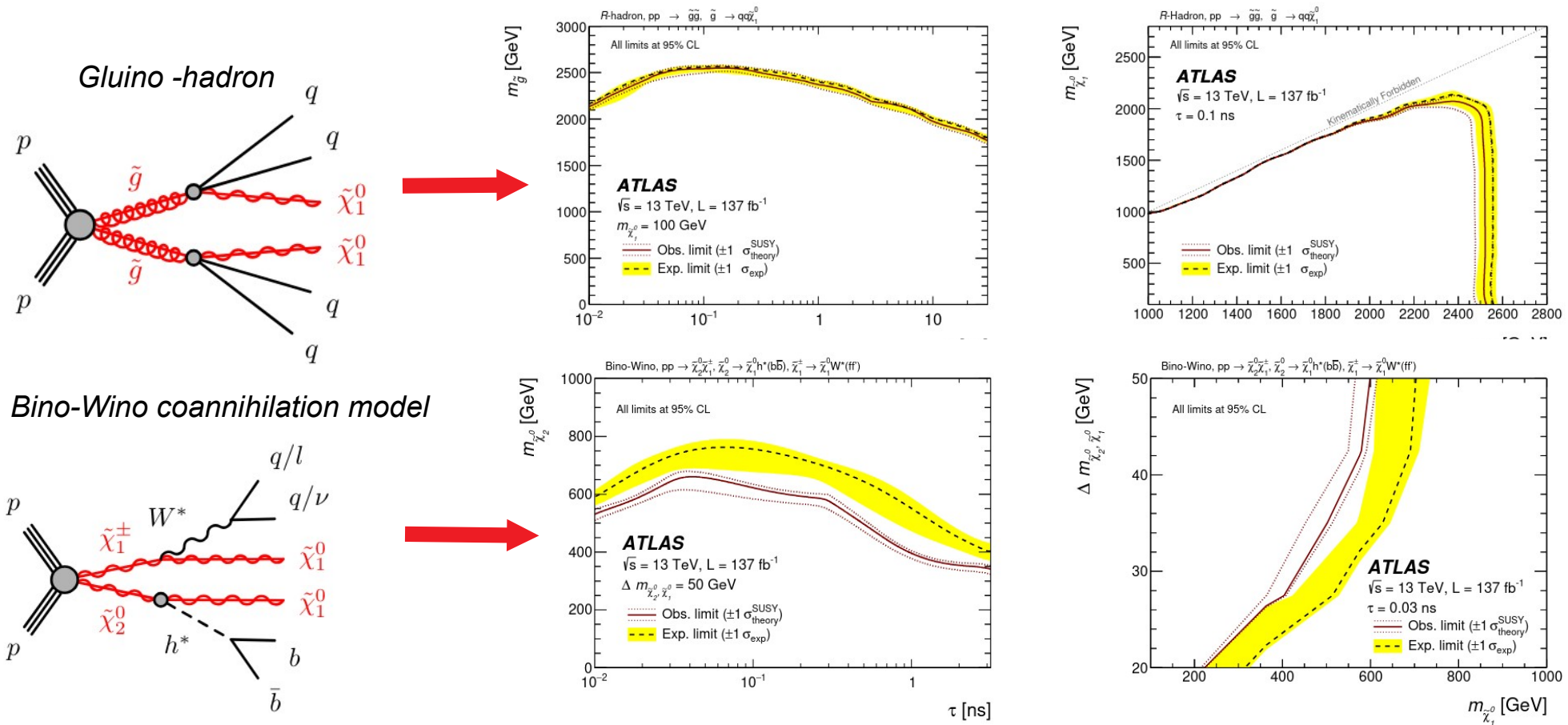

- SM benchmark models provide guidance on where to look for potential signals in the vast features of pp collisions.
- What if new **signatures** cannot be all covered by available BSM models?
- A broad search strategy based on anomaly detection offers an alternative approach.
- Instead of designing event selections around specific BSM models, design them to reject known SM events.
- ATLAS uses both “event-based” and “jet-based” anomaly detection methods since 2023

BSM-specific searches

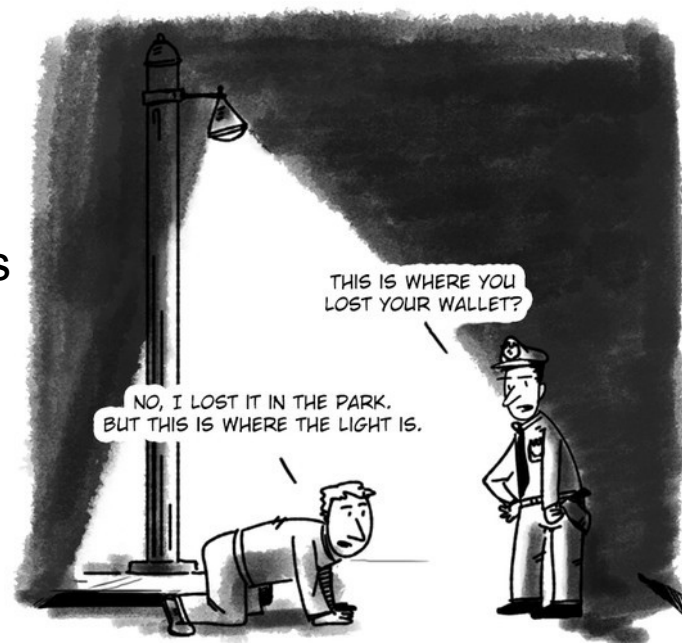

Focus on rejecting known Standard Model events while analyzing 'anomalous' events which may not be covered by specific BSM models ?

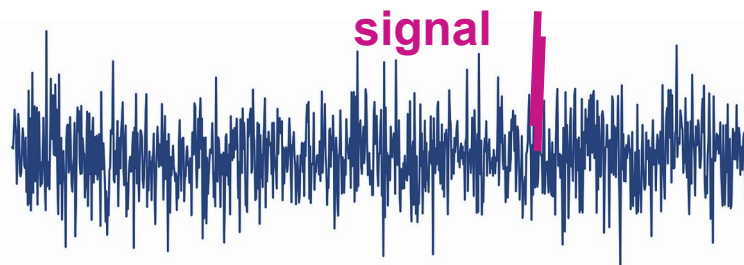

Noise (SM) to be rejected by AI-methods

Weakly supervised anomaly detection for resonant new physics

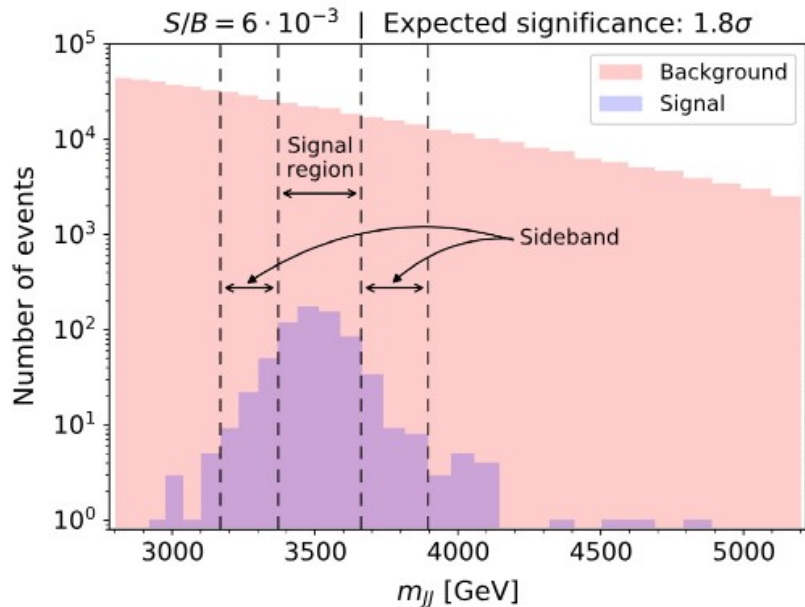

- ▼ Divide dijet mass spectrum into shifting signal-enriched region (SR) and signal-depleted sideband (SB) regions
- ▼ Learn background dijet distribution in SR from SBs – SALAD (reweighting MC to data) and CURTAINS (interpolation)
- ▼ Use jet mass, τ_{12} and τ_{23} with lower values indicating that the jets are more two- (three-) prong.
- ▼ Train NN classifier to separate populations of data in SR (1) and background estimated events (0) derived from SBs in Step 2
- ▼ After cut on NN score, perform bump hunt on remaining events

Network is learning difference between $Prob(b)$ and $Prob(s+b)$

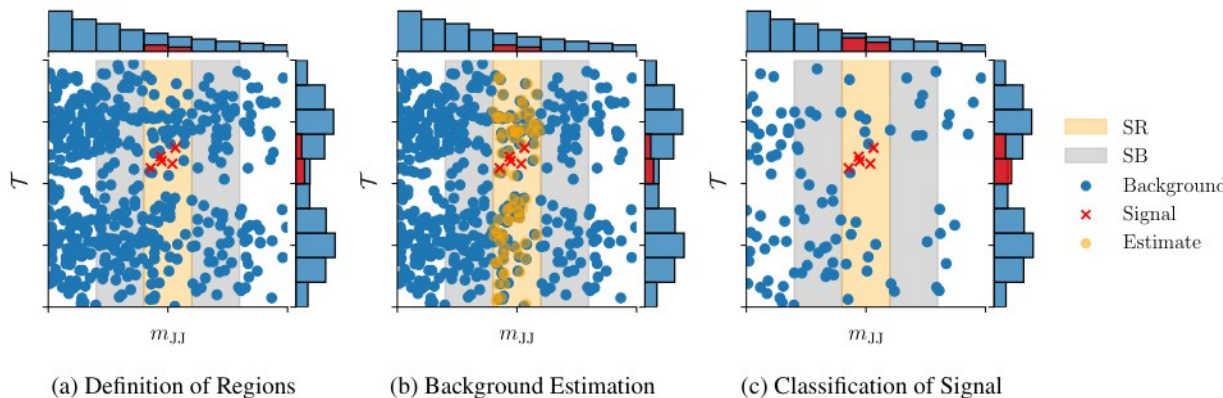

Also see:
[ATLAS, PRL 132 \(2024\) 081801](#)
where autoencoder learns the entire kinematics of events and reconstruct anomalies, without using jet shapes

Weakly supervised anomaly detection for resonant new physics

20 different BSM models of type $A \rightarrow B C$ where studied

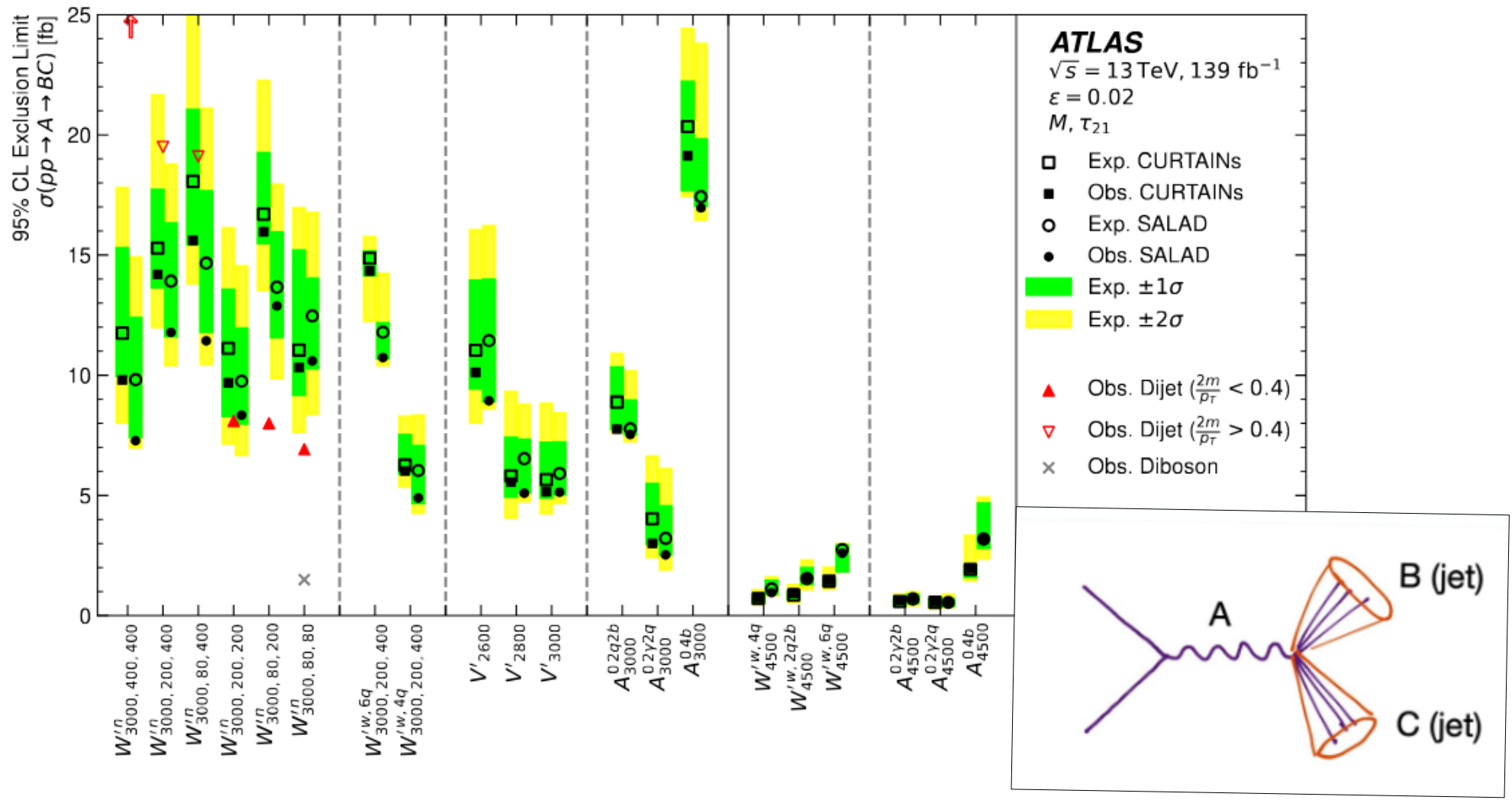

- ▼ Many more new and interesting results from Run 2,3 which I had no time to discuss : focus on full data sets and newest results
- ▼ Extensive program for BSM searches using innovative methods
- ▼ Refined studies with complex final state (jet, top, γ , $t\bar{t}$, W, Higgs, etc)
- ▼ Stay tuned: Ongoing Run3 analyses, some with very wide search using AI
 - ▼ 13 TeV \rightarrow 13.6 TeV CM energy, Increase in luminosity ($\times 2 \rightarrow$ larger statistics!)
- ▼ Various new techniques are motivated by BSM models, and we are also entering a new era of “wide” searches using AI techniques.

More information about ATLAS publications on ATLAS twiki - [ATLAS public results](#)



Backup

Searches for physics Beyond Standard Model (BSM)

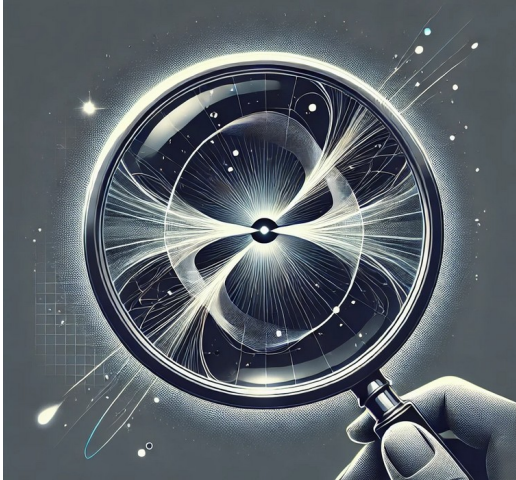

List of Publications:

ANA-EXOT-2018-56,
ANA-EXOT-2019-25,
ANA-EXOT-2022-32,
ANA-EXOT-2022-41,
ANA-EXOT-2023-17,
ANA-EXOT-2026-02,
SUSY-2020-08,
HMBS-2024-65,
EXOT-2021-34,
EXOT-2023-13,
EXOT-2024-21,
SUSY-2022-15,
HMBS-2024-66

- ▼ BSM: Searching for deviations from our expectations – discovering unusual effects and new particles.
- ▼ BSM signal models:
 - ▼ *SUSY - is an extension of the SM aiming to fill some of the gaps and predicting partner particles for SM particles.*
 - ▼ *Sequential SM predicting heavy W' / Z' bosons*
 - ▼ *Grand unified theories*
 - ▼ *Two Higgs Doublet Models (2HDM)*
 - ▼ *Heavy Vector Triplet (HVT) models*
 - ▼ *Extra dimensions*
 - ▼ *Models with CP-violation*
 - ▼ *Leptoquark (LQ) models*
 - ▼ *Dark matter (DM) models*
 - ▼ *.. etc. etc.*

ATLAS detector for the HL-LHC

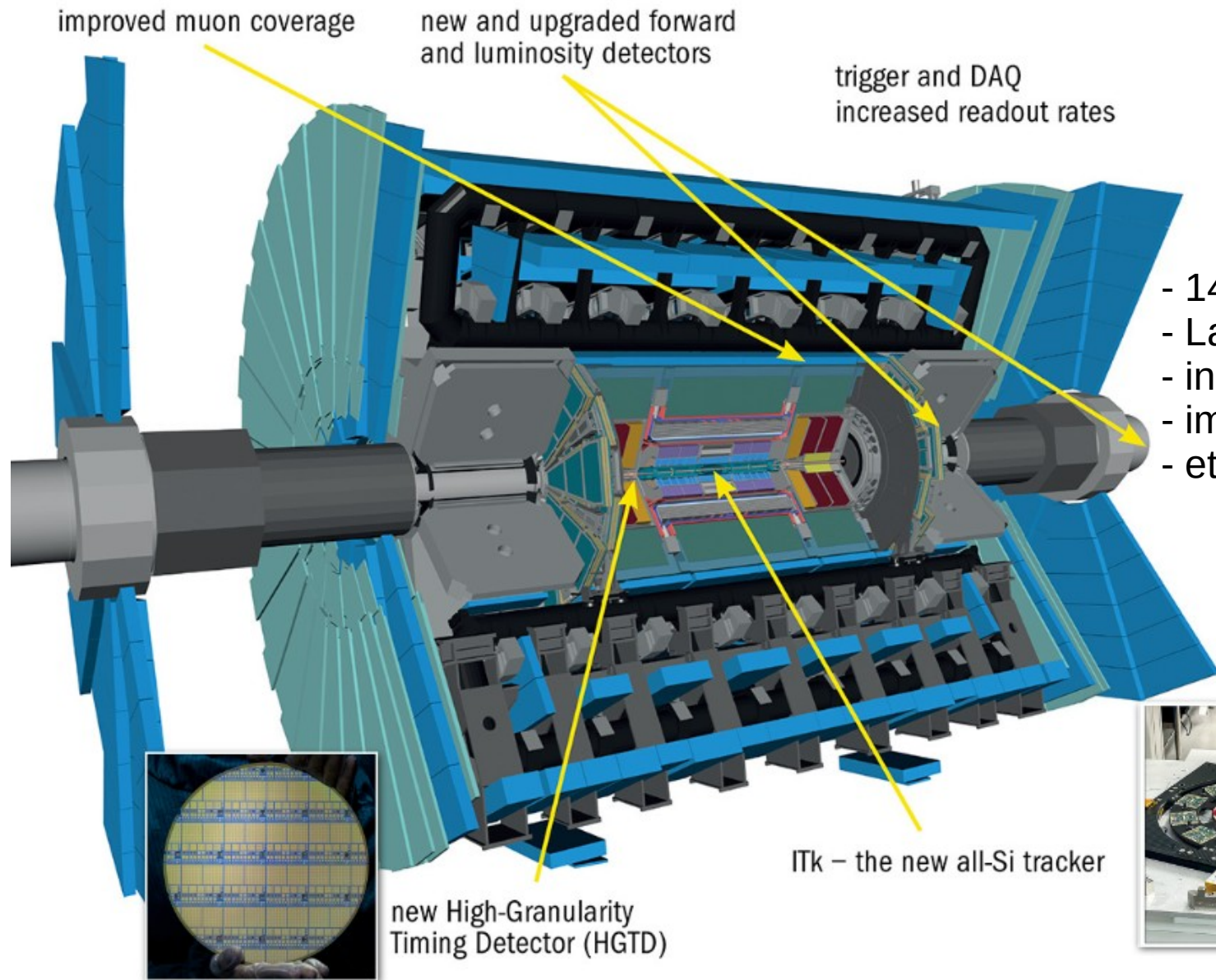

- 14 TeV energy
- Large statistics
- increased solid angle
- improved vertexing
- etc.

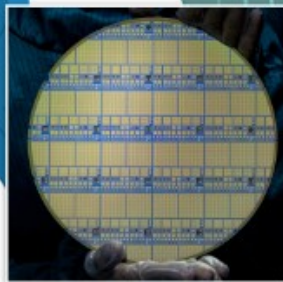

Matthias Danninger | SFU

