



Energy Dependency of Fission Product Yields

Diego Ramos

on behalf of the Fission@VAMOS collaboration

◆ FISSION@VAMOS

- Heavy ion Beams (Xe,Th,U, Pb)
- Inverse-Kinematics Surrogate-Induced Fission

Surrogate Reactions technique:

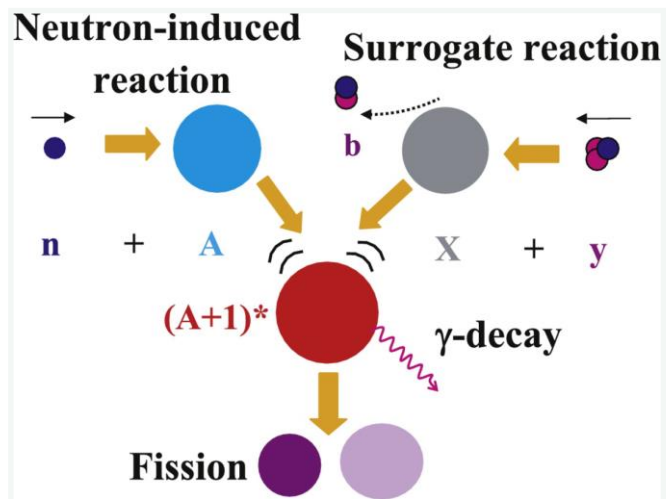

Surrogate reactions give access to exotic fissioning systems, difficult to produce through n-induced reactions

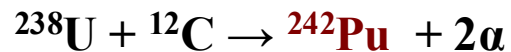
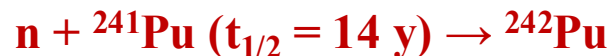

Surrogate reactions permit to explore the **impact of the incoming channel** into the final fission-fragment distributions

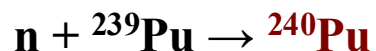
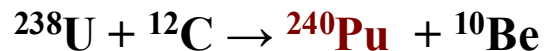

Inverse Kinematics technique:

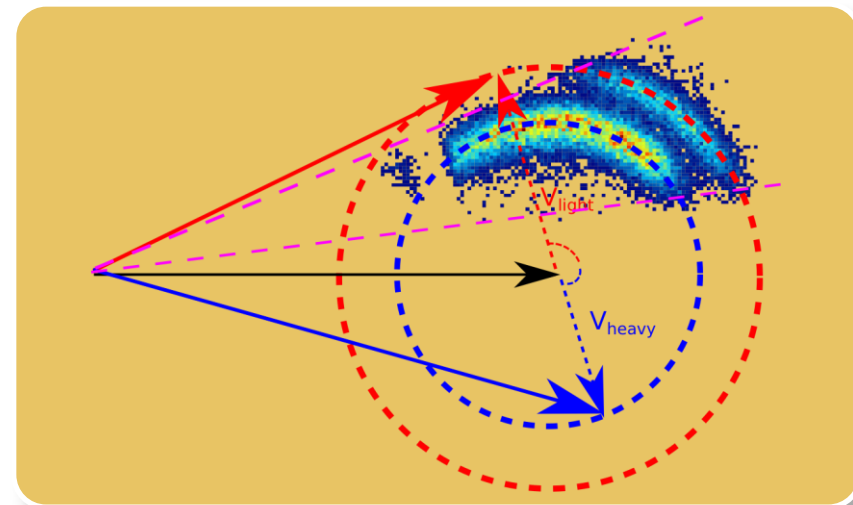

Inverse kinematics provide the capability of fission-fragments **nuclear-charge** identification

Coulomb energies provide low angular straggling and small Lorentz boost:
good velocity resolution in CM

◆ FISSION@VAMOS

- Heavy ion Beams (Xe,Th,U, Pb)
- Inverse-Kinematics Surrogate-Induced Fission

- MultiNucleon Transfer Reactions ($E_{\text{beam}} \simeq 6 \text{ MeV/u}$)

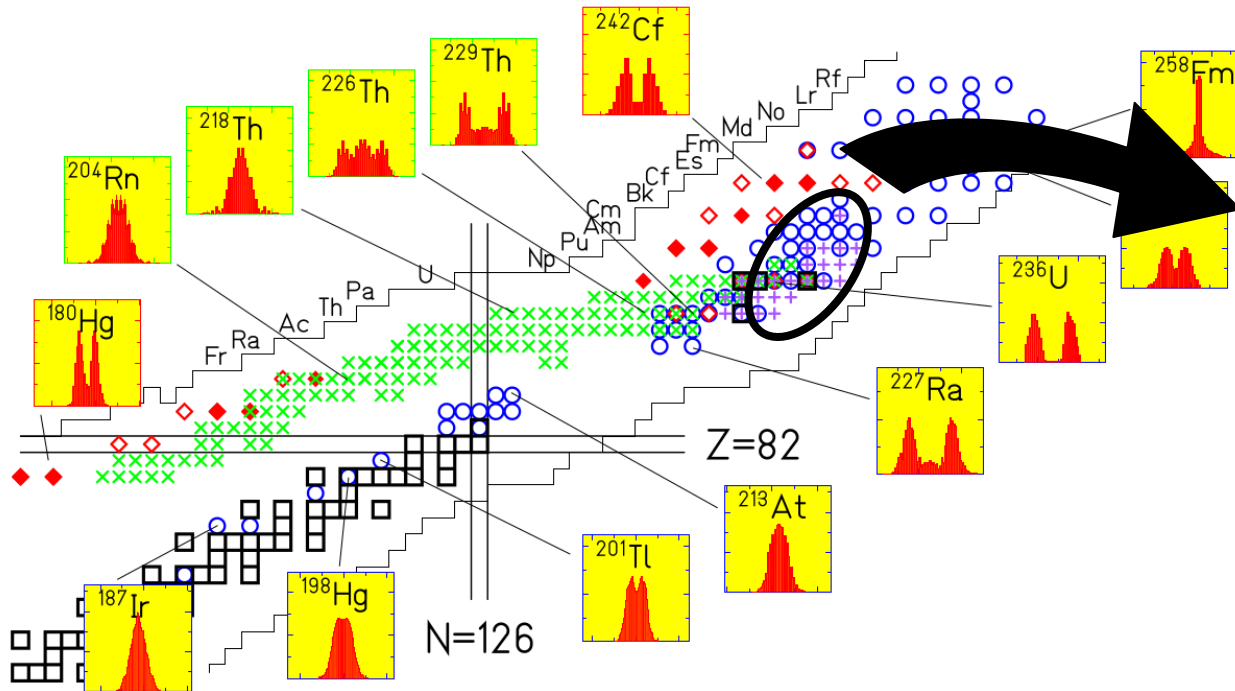

K-H. Schmidt et B. Jurado Rep. Prog. Phys. 81 (2000) 106301

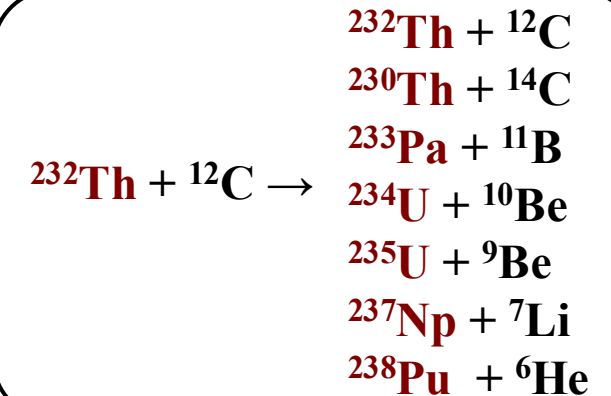
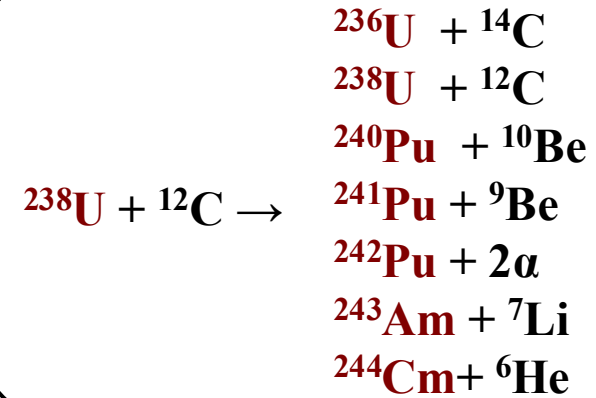

◆ FISSION@VAMOS

- Heavy ion Beams (Xe,Th,U, Pb)
- Inverse-Kinematics Surrogate-Induced Fission

- MultiNucleon Transfer Reactions ($E_{\text{beam}} \simeq 6 \text{ MeV/u}$)

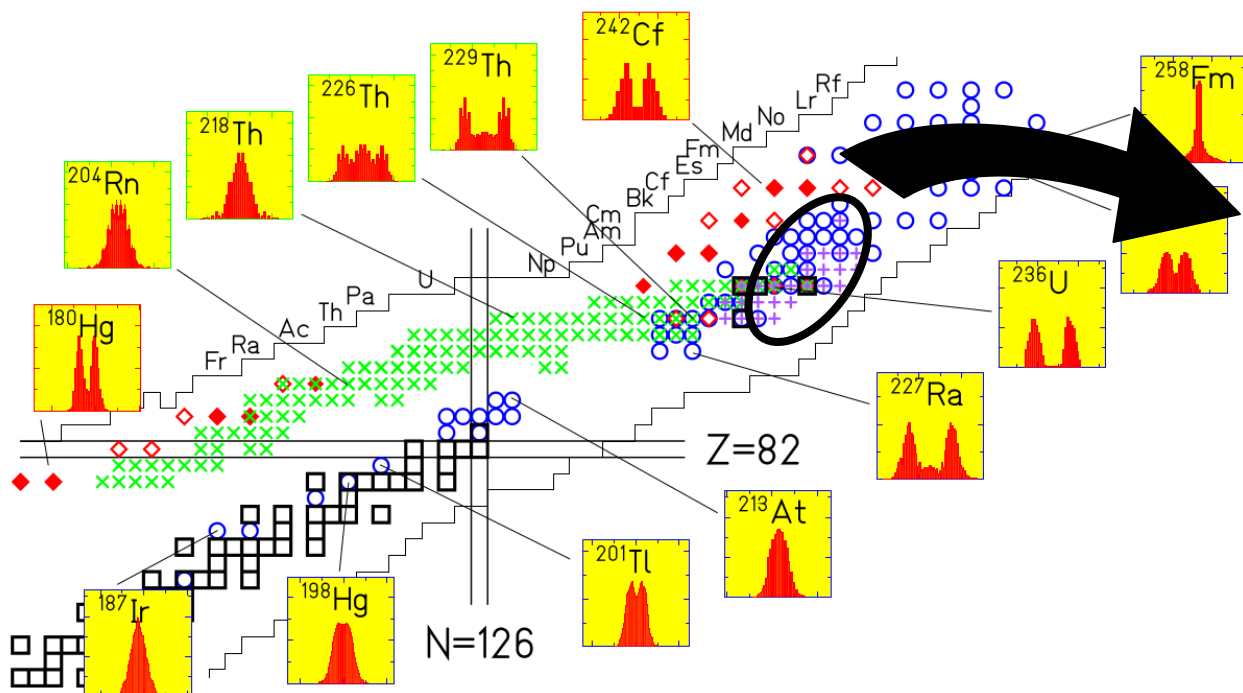

K-H. Schmidt et B. Jurado Rep. Prog. Phys. 81 (2000) 106301

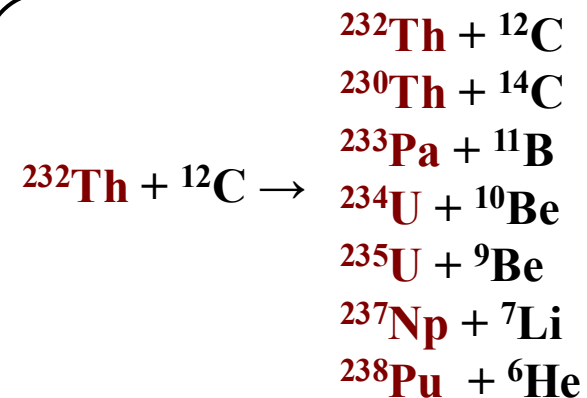
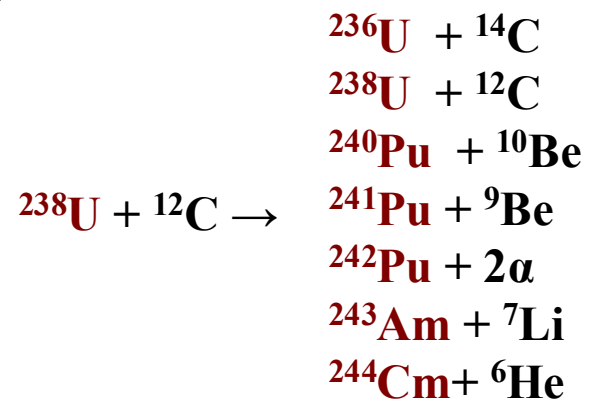

Complete Isotopic-distribution of fission-fragments Yields

Isotopic Identification of Heavy Ions

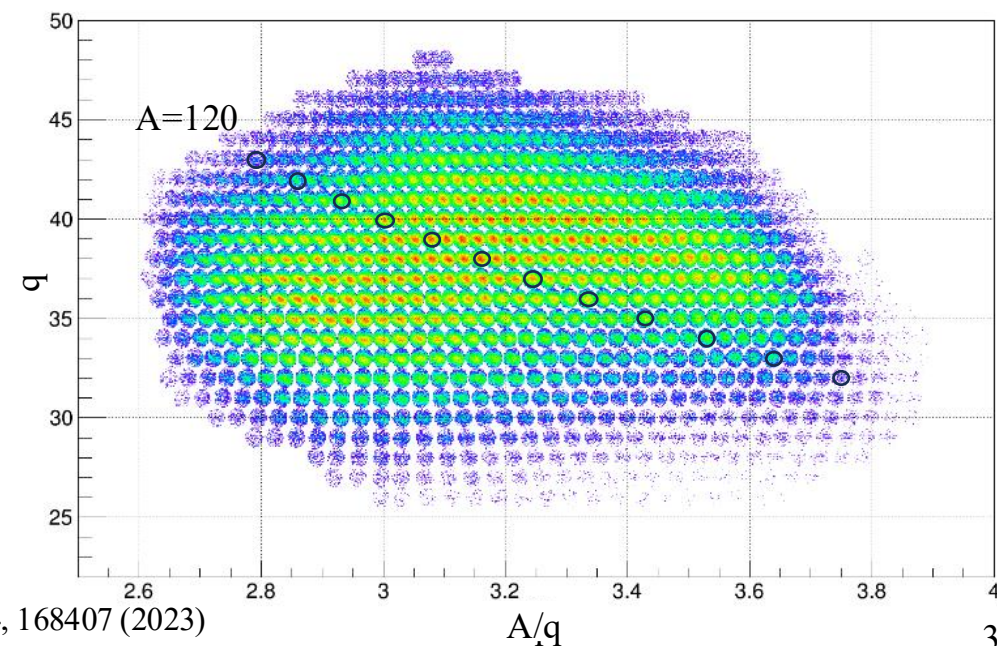
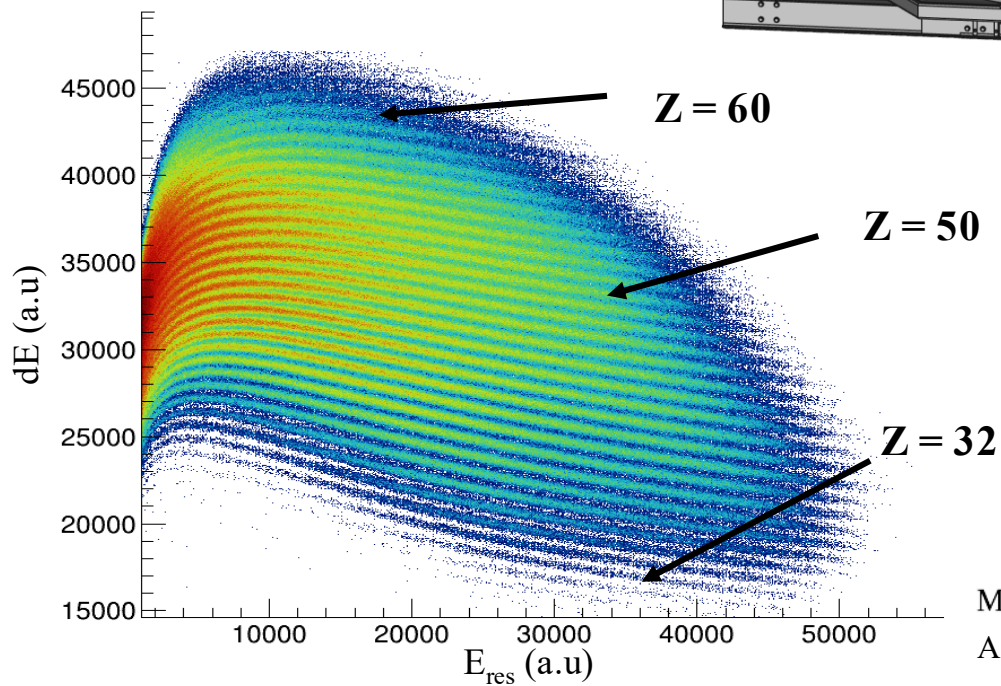
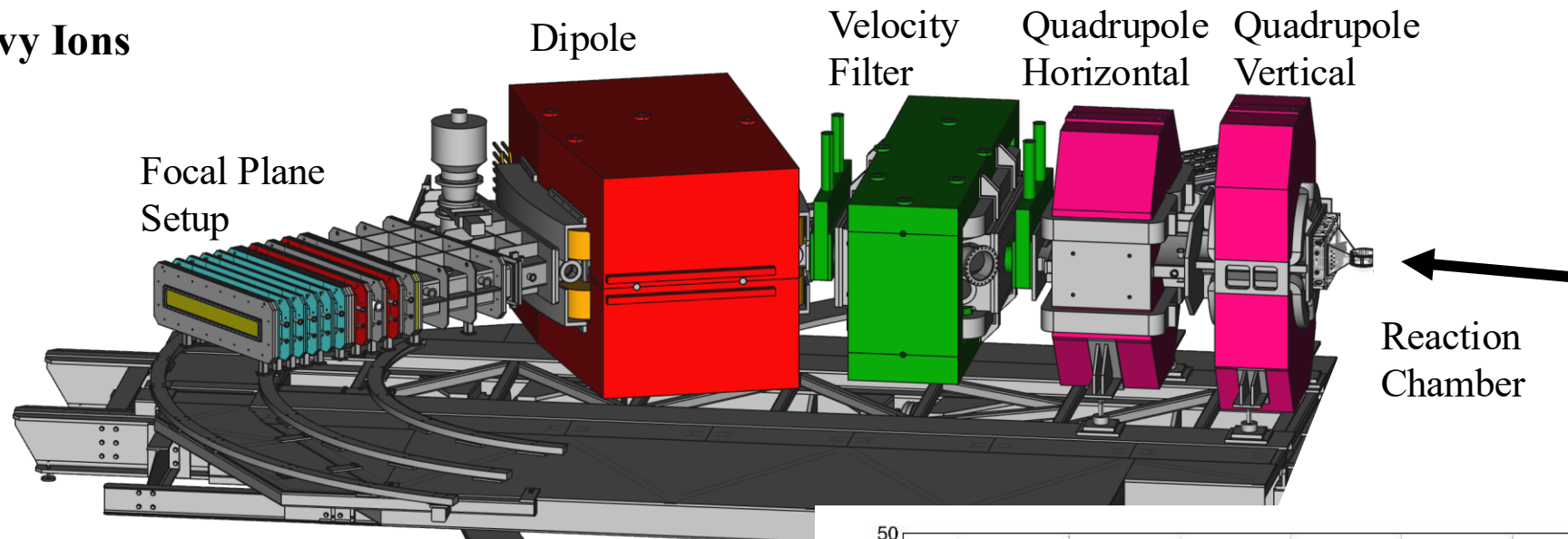
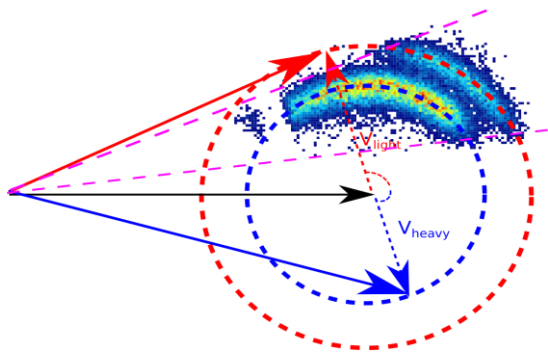

M. Rejmund et al., NIM A 646 (2011) 184

A. Lemasson & M. Rejmund, NIM A 1054, 168407 (2023)

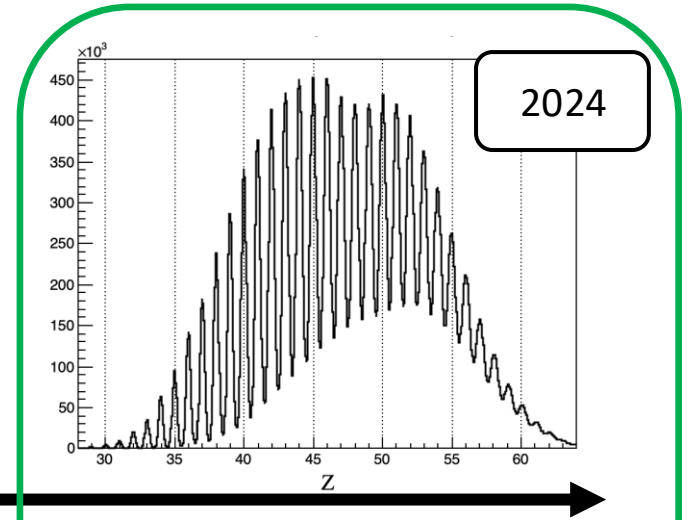
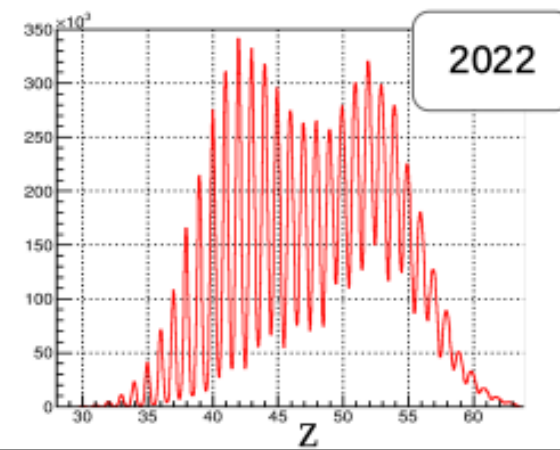
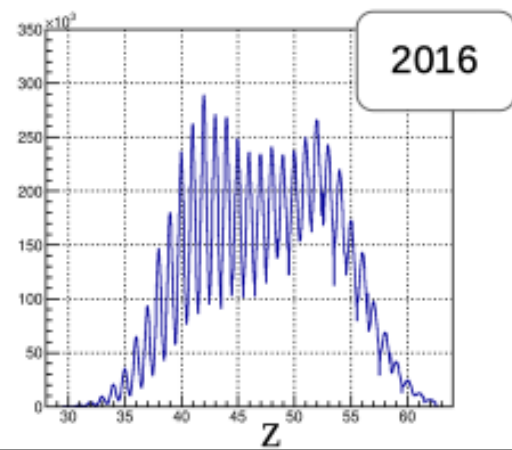
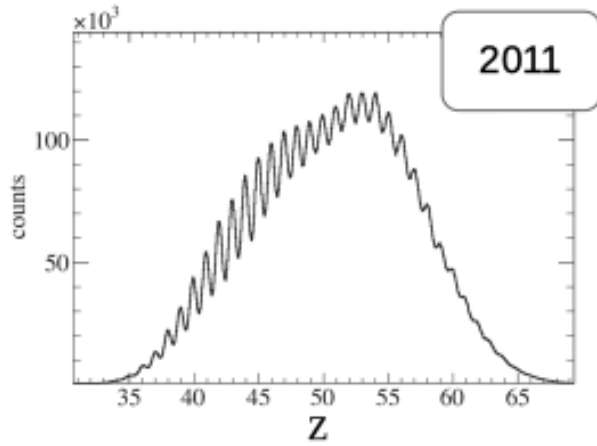

No Target PS-MWPC
DC + IC + Si (focal plane)

Target PS-MWPC
High Segmentation IC
Digital Electronics

Focal Plane PS-MWPC
Higher Segmentation IC

Neural Networks Implementation

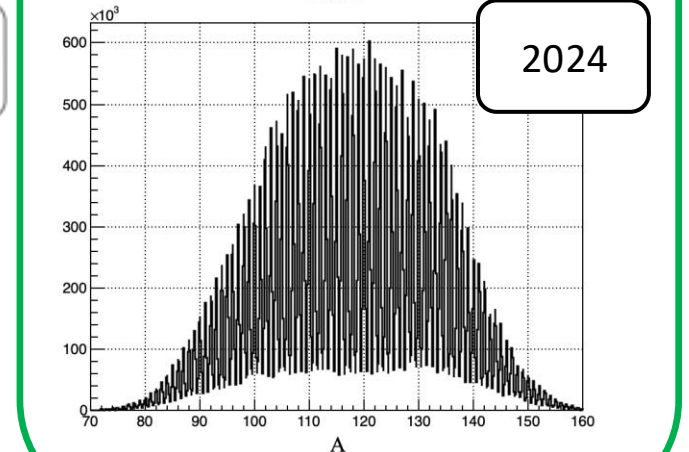
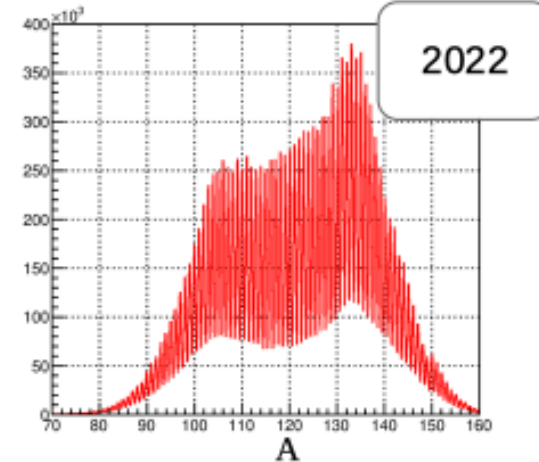
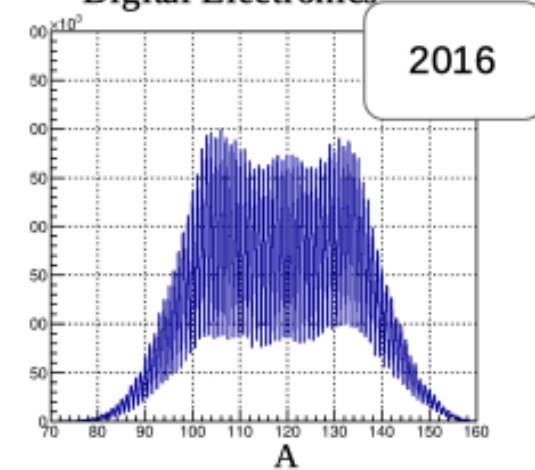
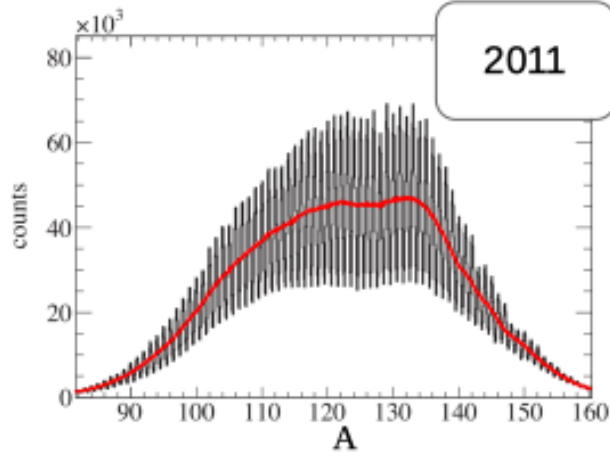

Multi-nucleon Transfer Reactions
Access to Actinides

- ^{238}U beam at ~ 6 MeV/u (Coulomb energies)

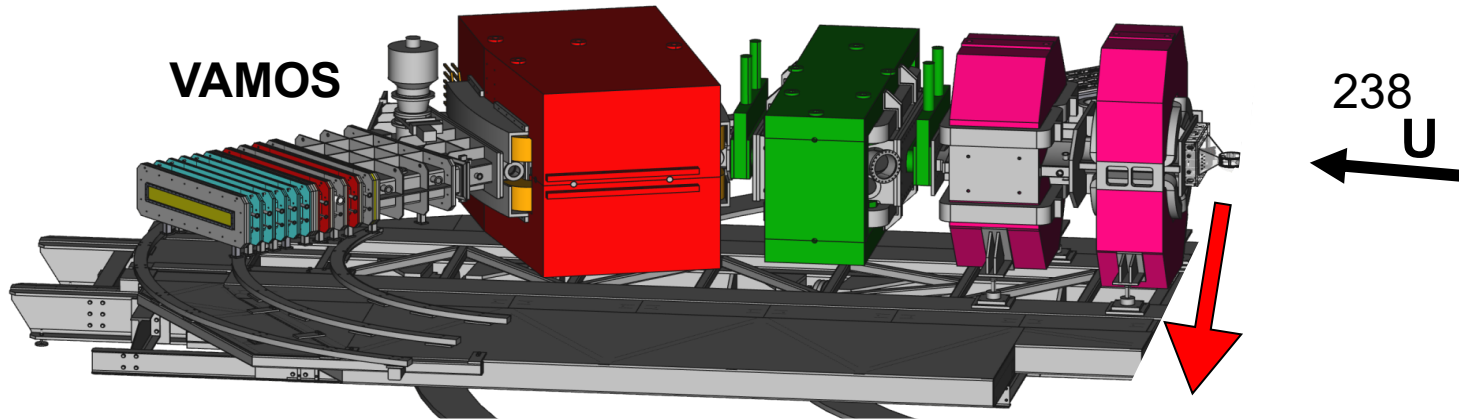

• STRIP SILICON TELESCOPE

- Identification of the fissioning system by detection of the target-like recoil
- Measurement of the Excitation Energy by reconstruction the binary reaction
- Measurement to fission probabilities by detection of fission fragments

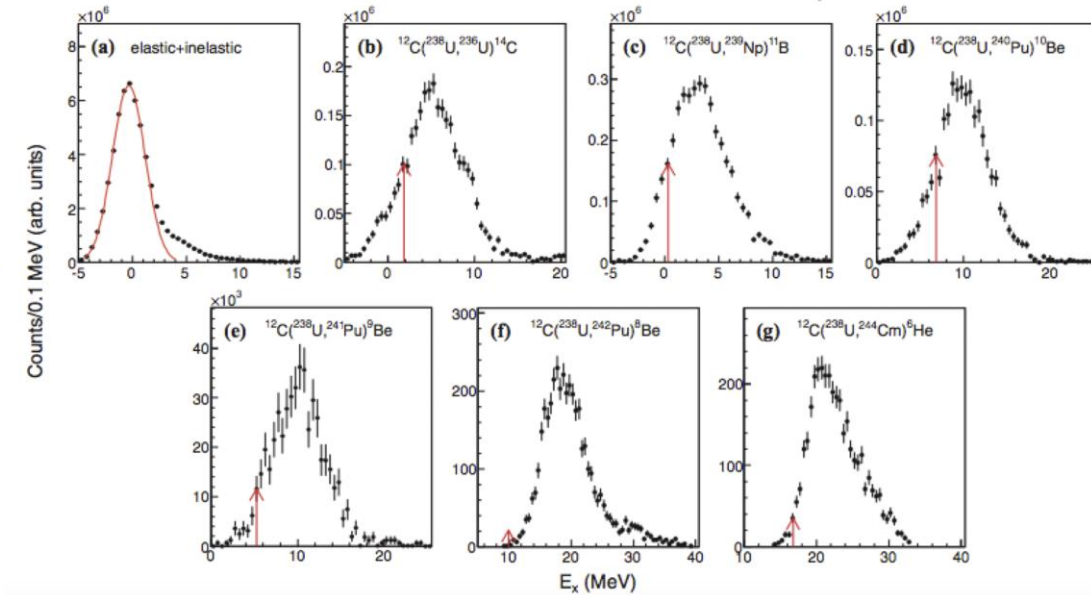
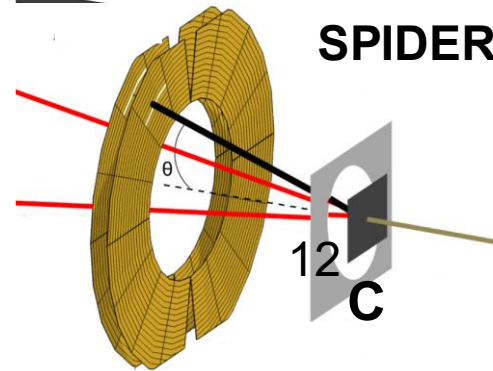
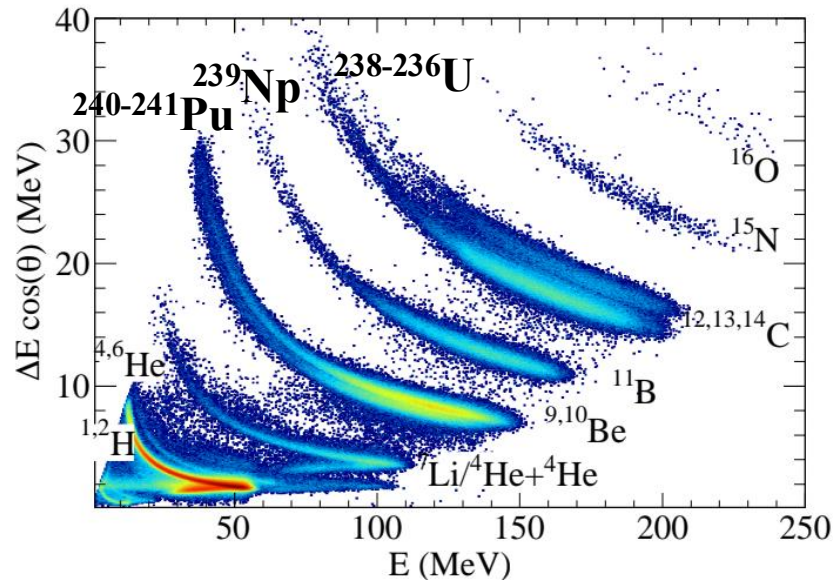

E_x Resolution = 2.7 MeV (FWHM)

$^{12}\text{C} (^{238}\text{U}, ^{240}\text{Pu}^*) ^{10}\text{Be}$
Fission Yields of ^{240}Pu and E_x

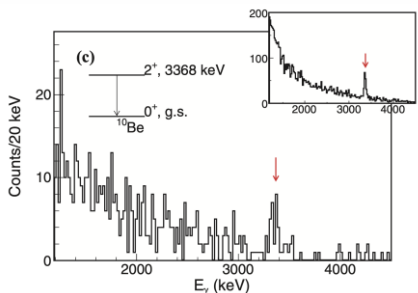
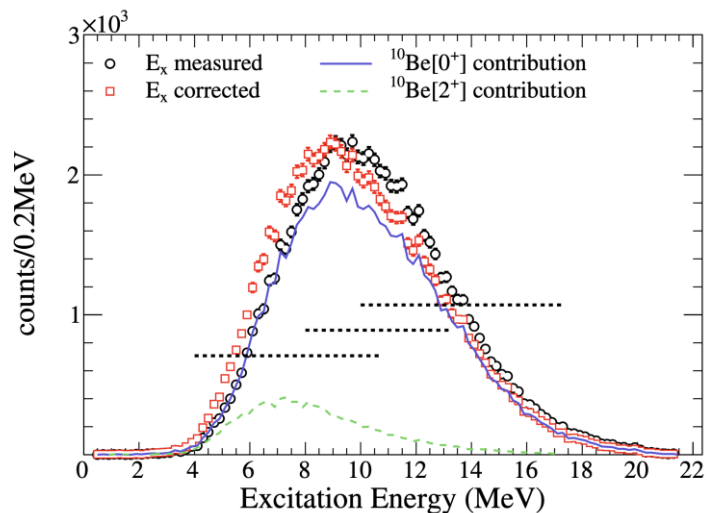
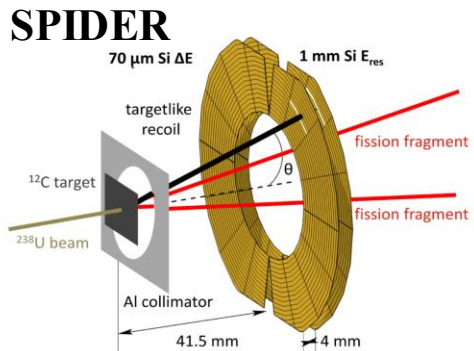

EXOGAM

$$P(^{10}\text{Be}[2^+]) = 0.14 \pm 0.04$$

VAMOS

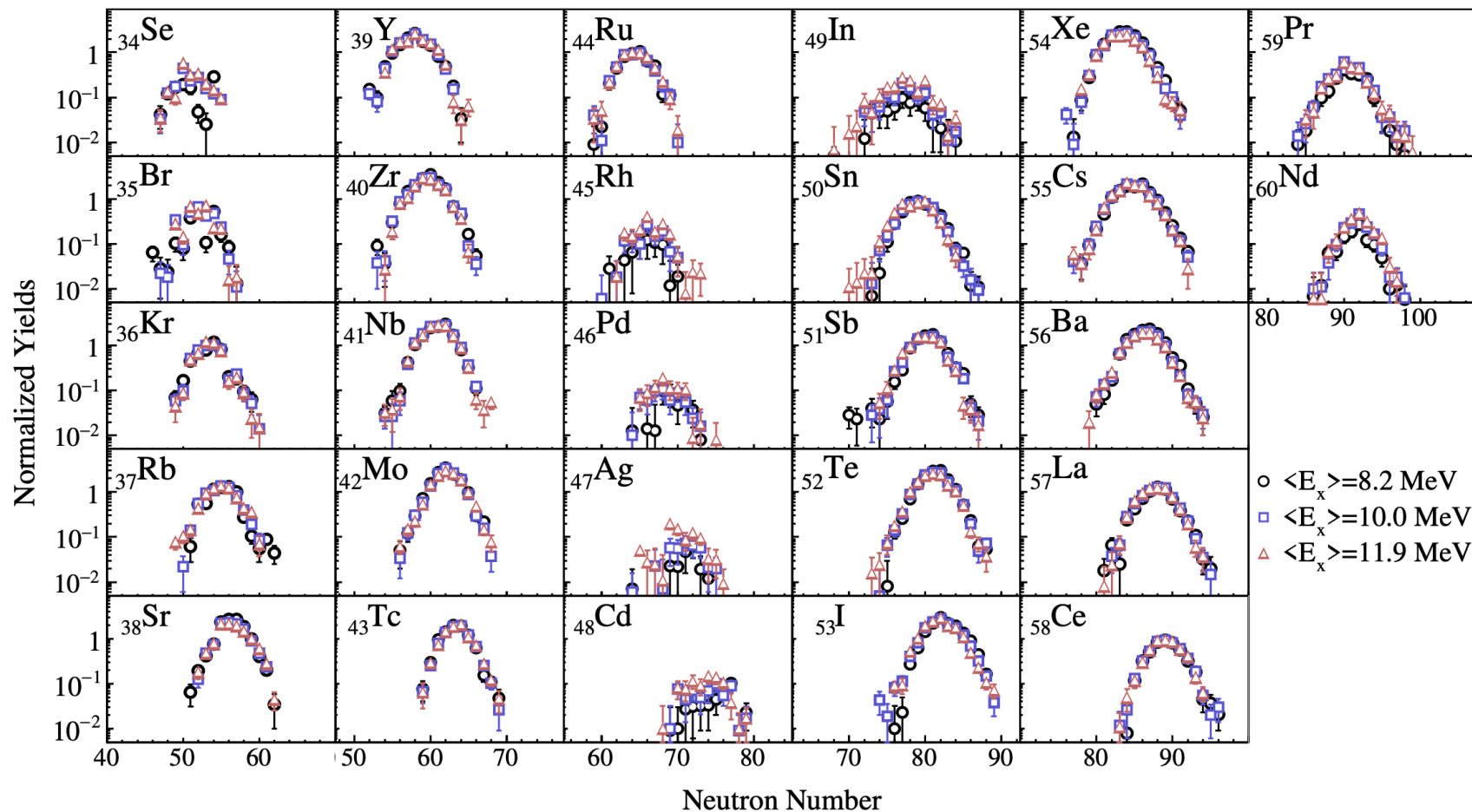

Full distribution of post-neutron evaporation
Isotopic Fission Yields as a function of E_x

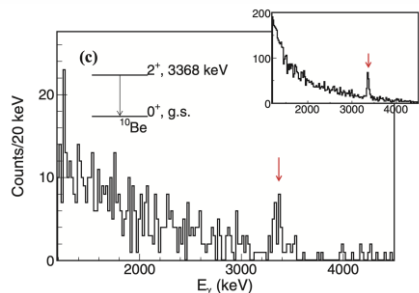
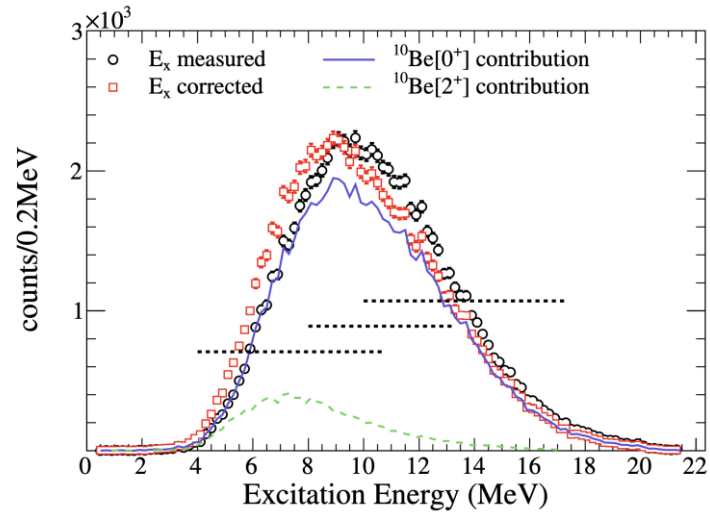
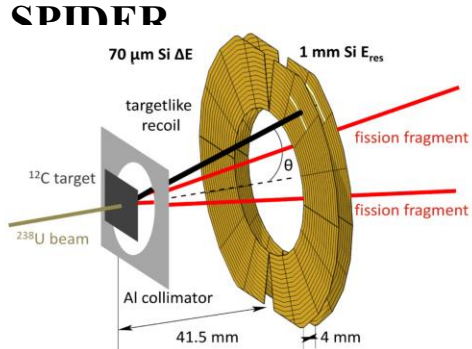

EXOGAM

$$P(^{10}\text{Be}[2^+]) = 0.14 \pm 0.04$$

VAMOS

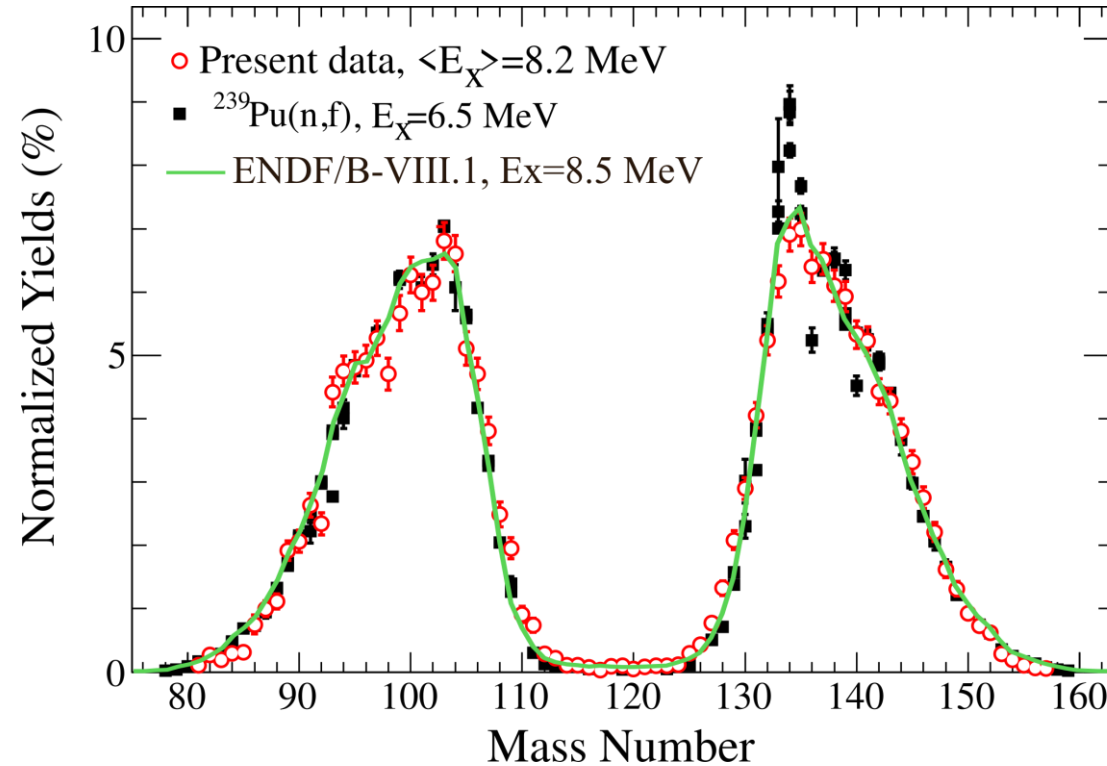

- **Post-neutron evaporation mass yields.**
- Very good agreement with n-induced fission (H. Naik et al. NSE 196, 824 (2022)) and evaluation (ENDF)
- **Evidence of E_x effect in $A \sim 132$**

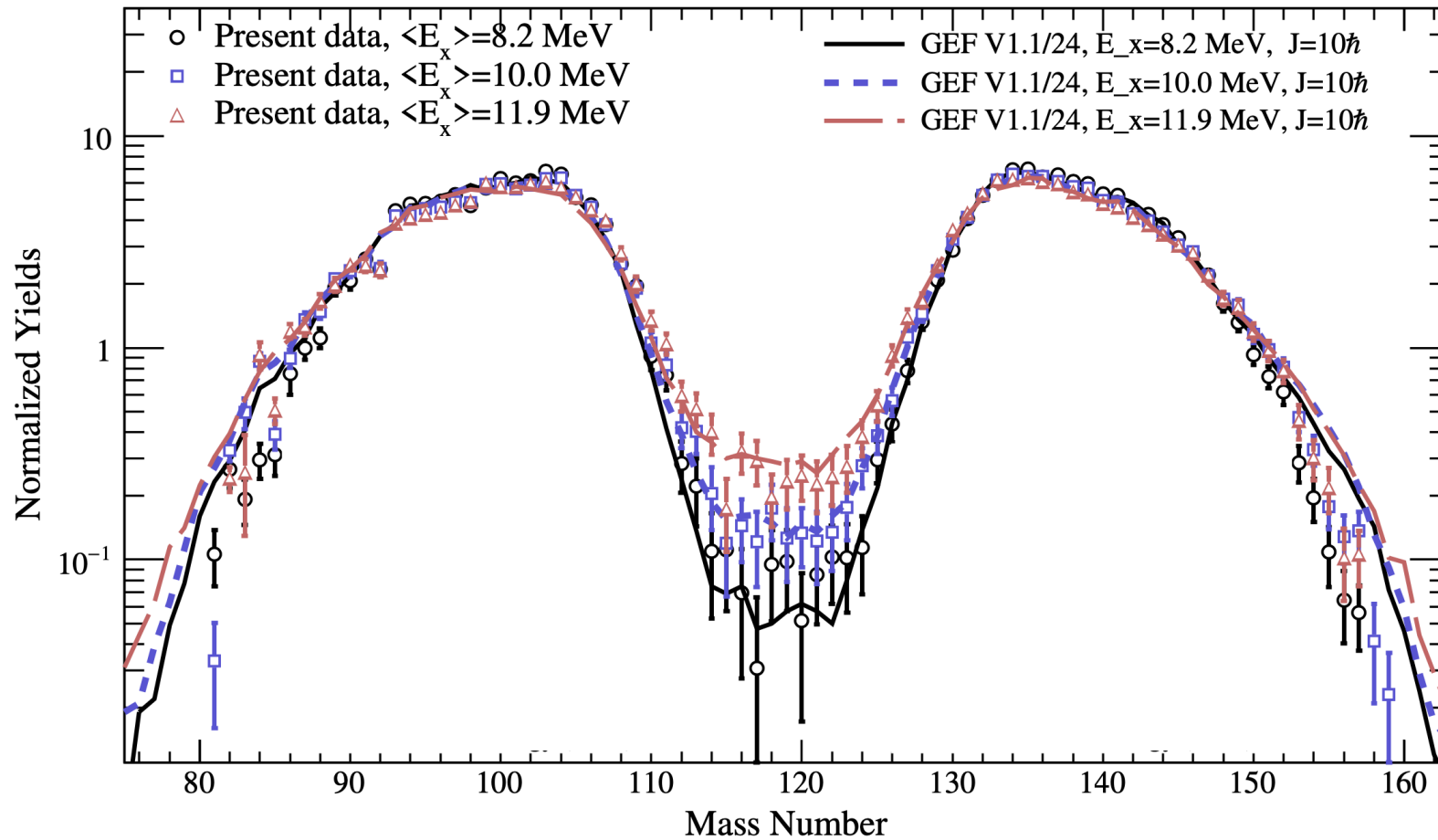

- Good description of the **Damping of Shell effects**
- Larger **super-asymmetric fission component**

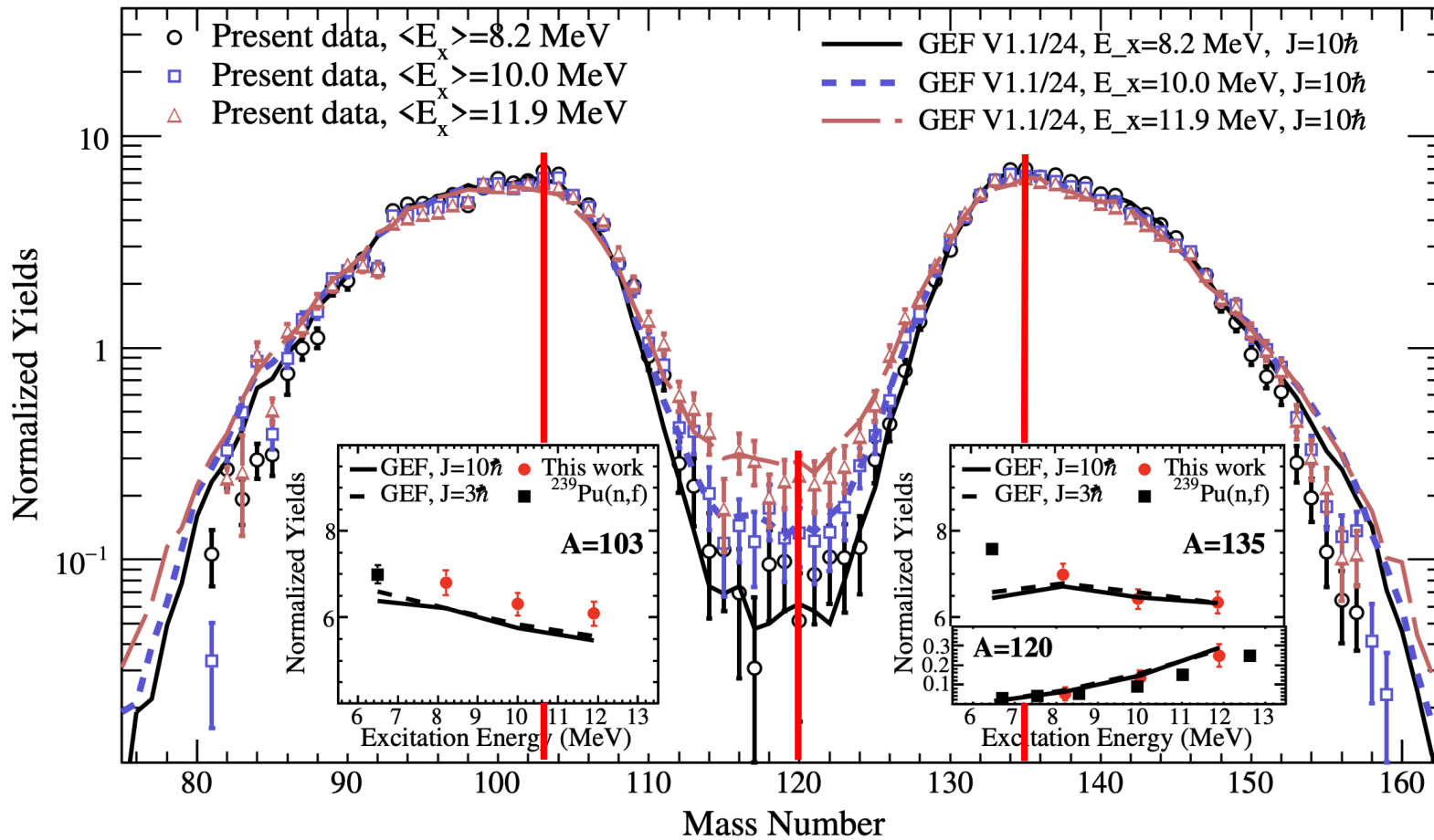

- Good description of the **Damping of Shell effects**
- Larger **super-asymmetric fission component**
- GEF does not predict significant effect of J of the system in mass yields
- The maximum yield in the light fragments is systematically higher than GEF

New Detection Generation **PISTA**

NEW COLLABORATION: GANIL – CEA-DAM BRUYERES-LE-CHÂTEL

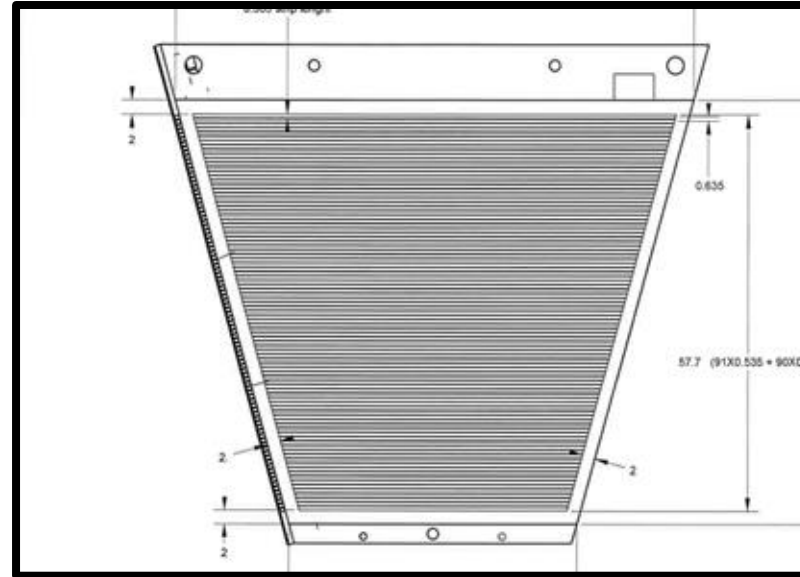
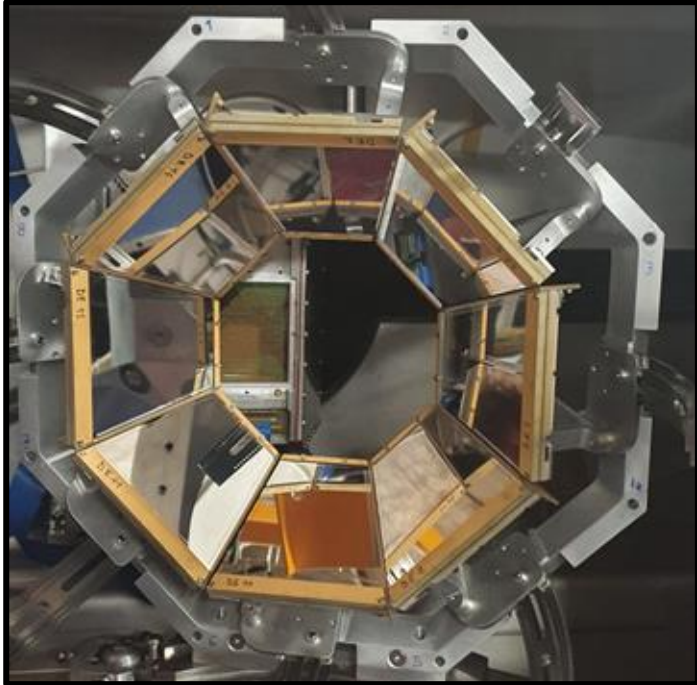

DE – E Silicon Telescope

dE :

100 μ m thick

0.53 mm horizontal strips

E :

1 mm thick

1.17 mm vertical strips

10 cm from the target:

Angular coverage: 30 – 60 deg

Angular precision: < 5 mrad

Goals:

Isotopic identification from He to C

E_x resolution < 1 MeV

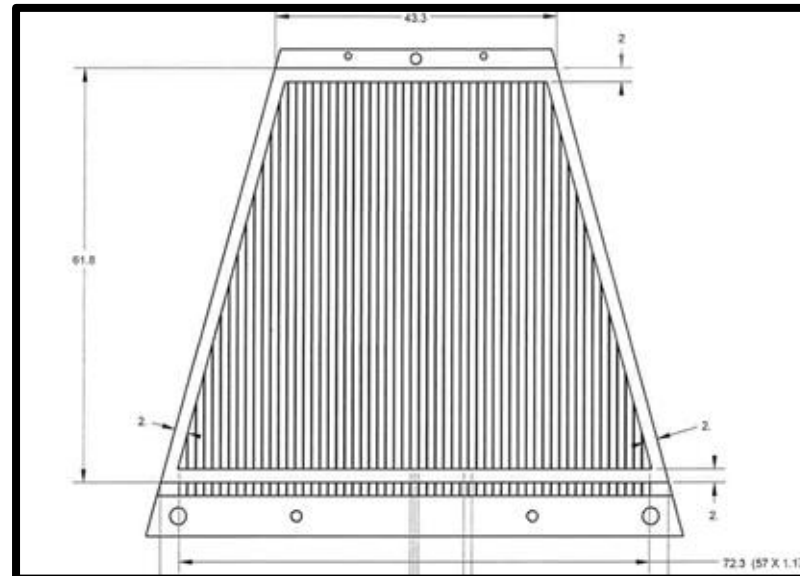

Target-like recoil Identification Matrix

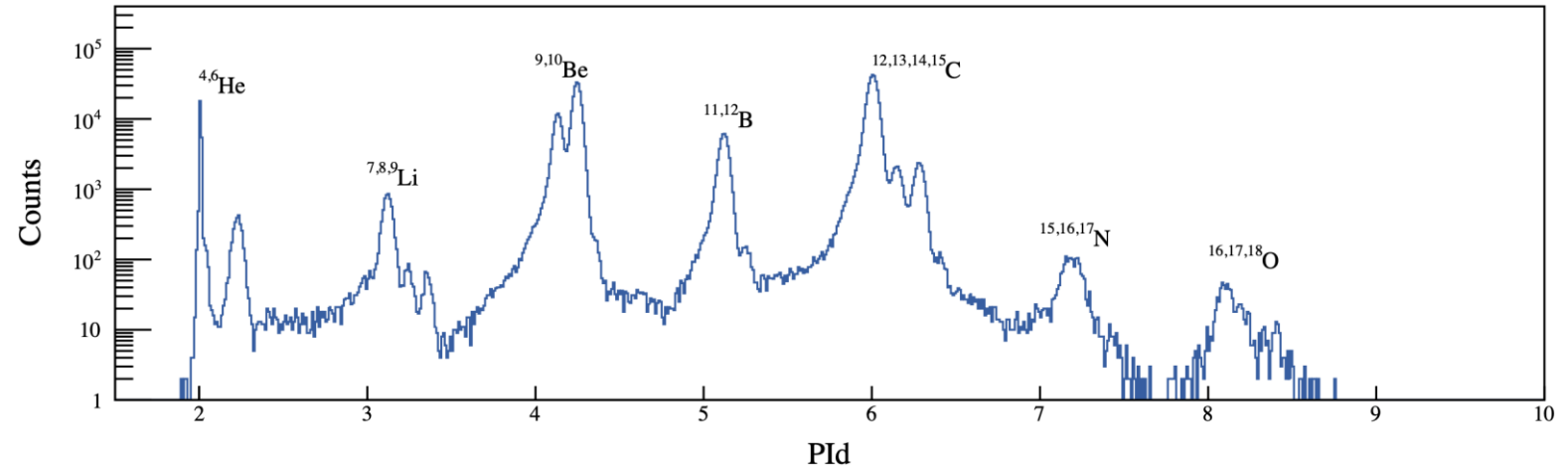
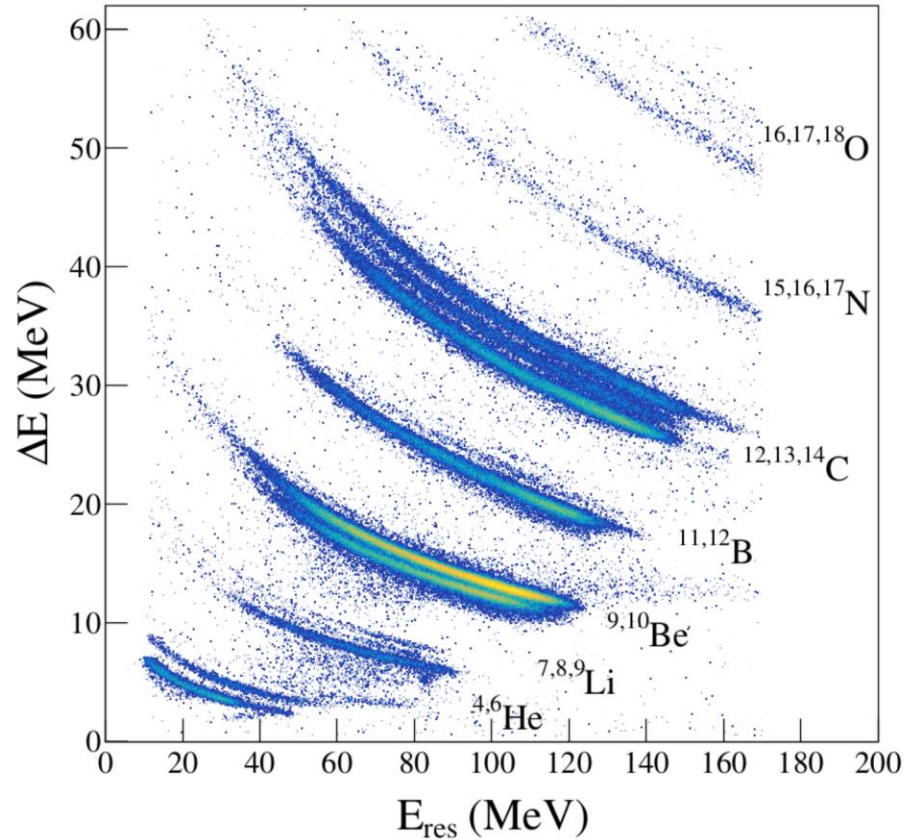

Mass resolution of 1.1% in Carbon region

Target-like recoil Identification Matrix

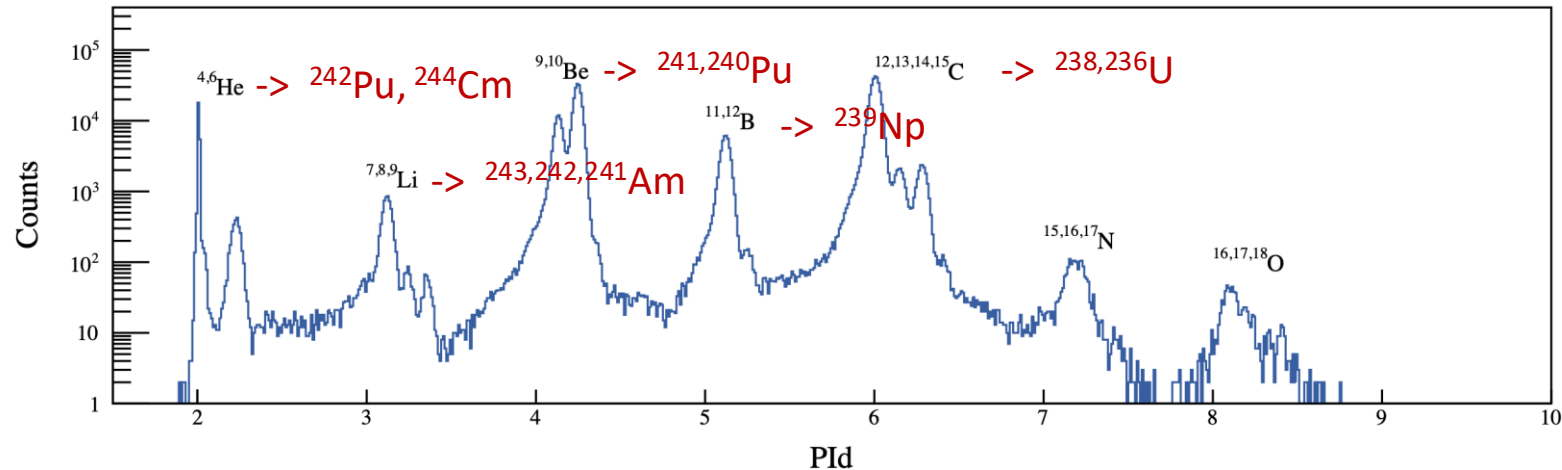
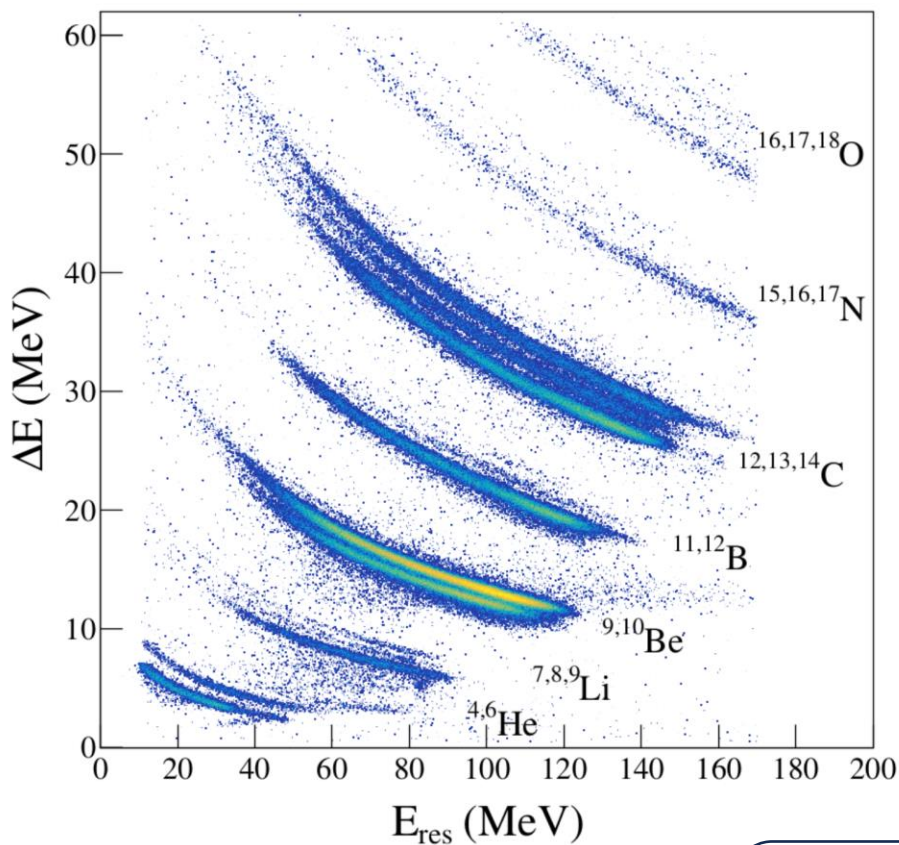

Mass resolution of 1.1% in Carbon region

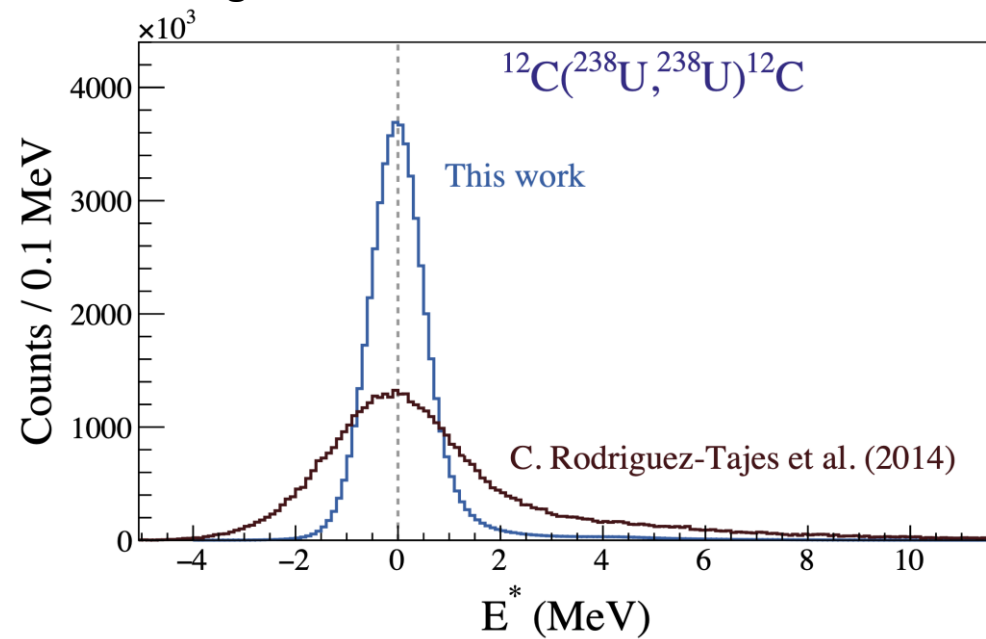

Lucas Bégué (PhD GANIL – CEA DAM)

E_x resolution = 511 keV (elastic)
Expected E_x resolution : 370 keV
 (with interaction point at target)

New ^{232}Th beam at GANIL
Access to New Fissioning Systems

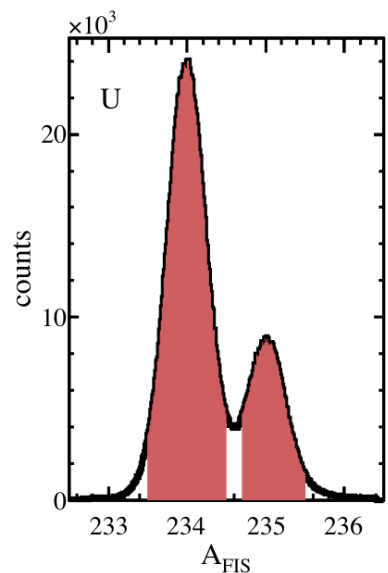

Identification of ^{234}U from ^{10}Be

Excitation energy distribution of ^{234}U in coincidence with fission

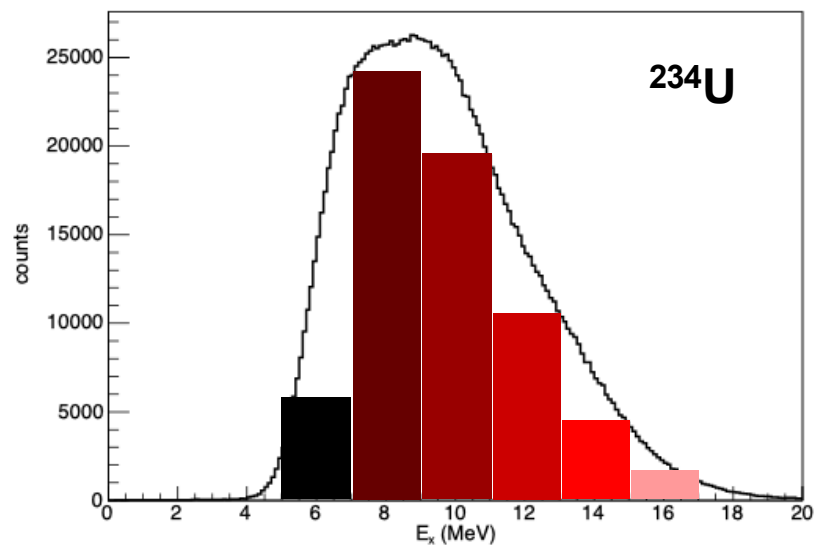

Elemental Fission Yields for different ranges of E_x

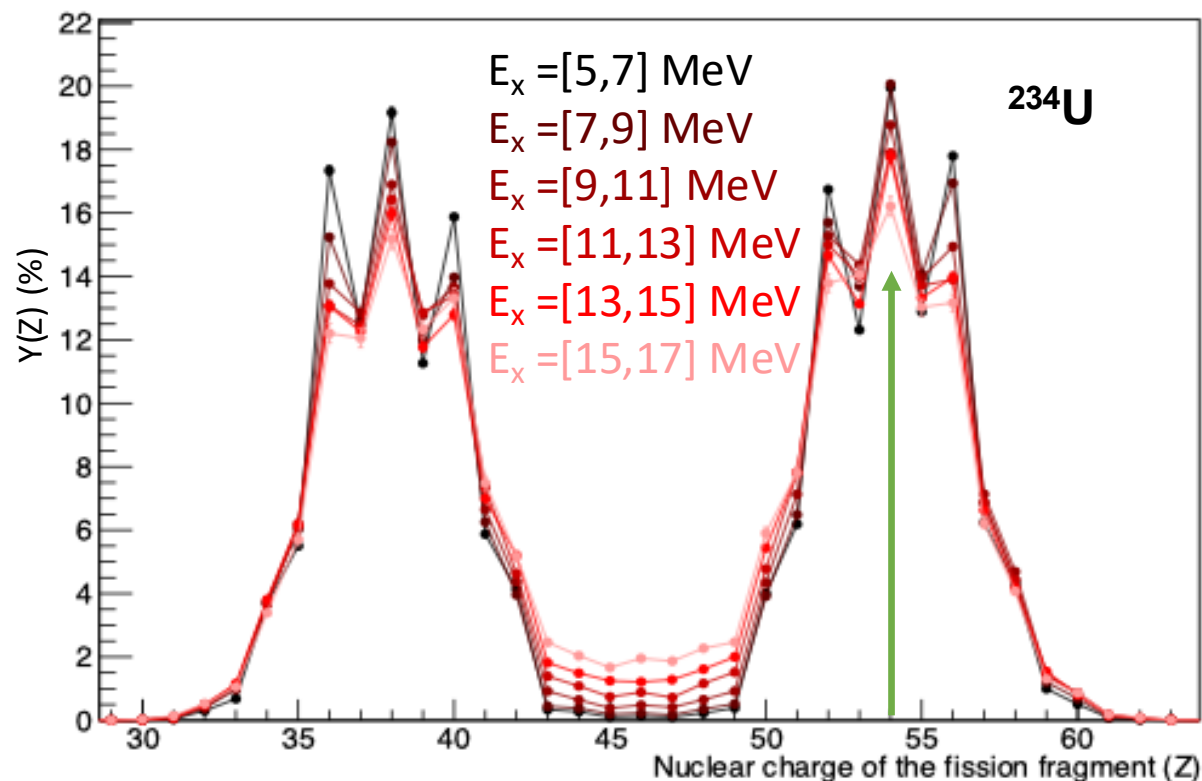

- Maximum Yield at $Z=54$
- Feeding of Yields at symmetry: Damping of shell effects
- Reduction of the even-odd staggering

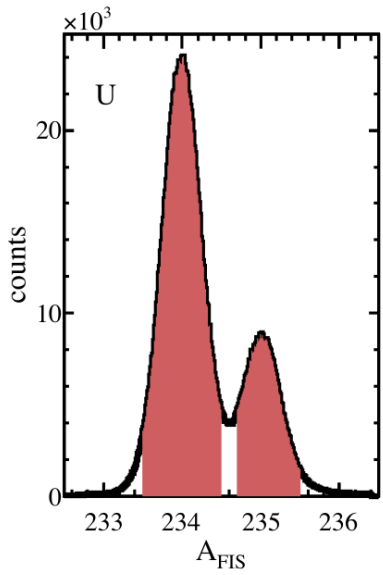

Identification of ^{234}U from ^{10}Be

Excitation energy distribution of ^{234}U in coincidence with fission

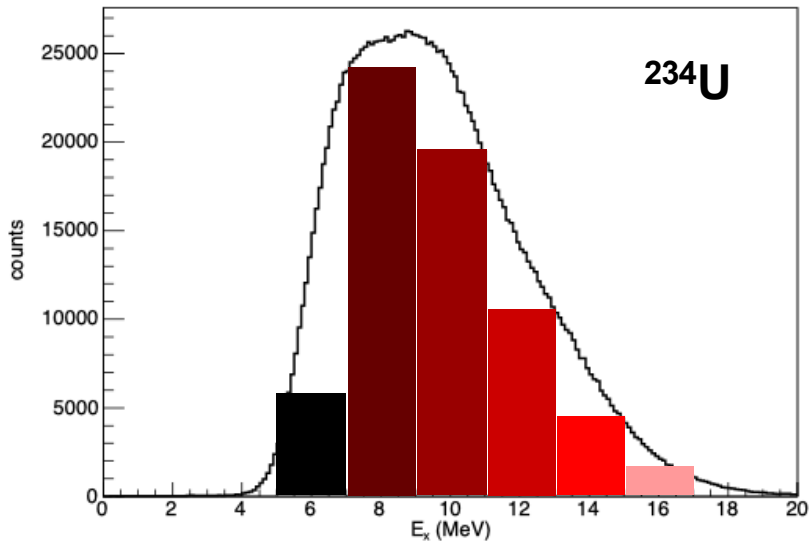

Isotonic Fission Yields for different E_x

- Heavy Fragment less neutron rich for high E_x
- Distribution narrower around $N=82$ for high E_x
- No position variation in the Light Fragment

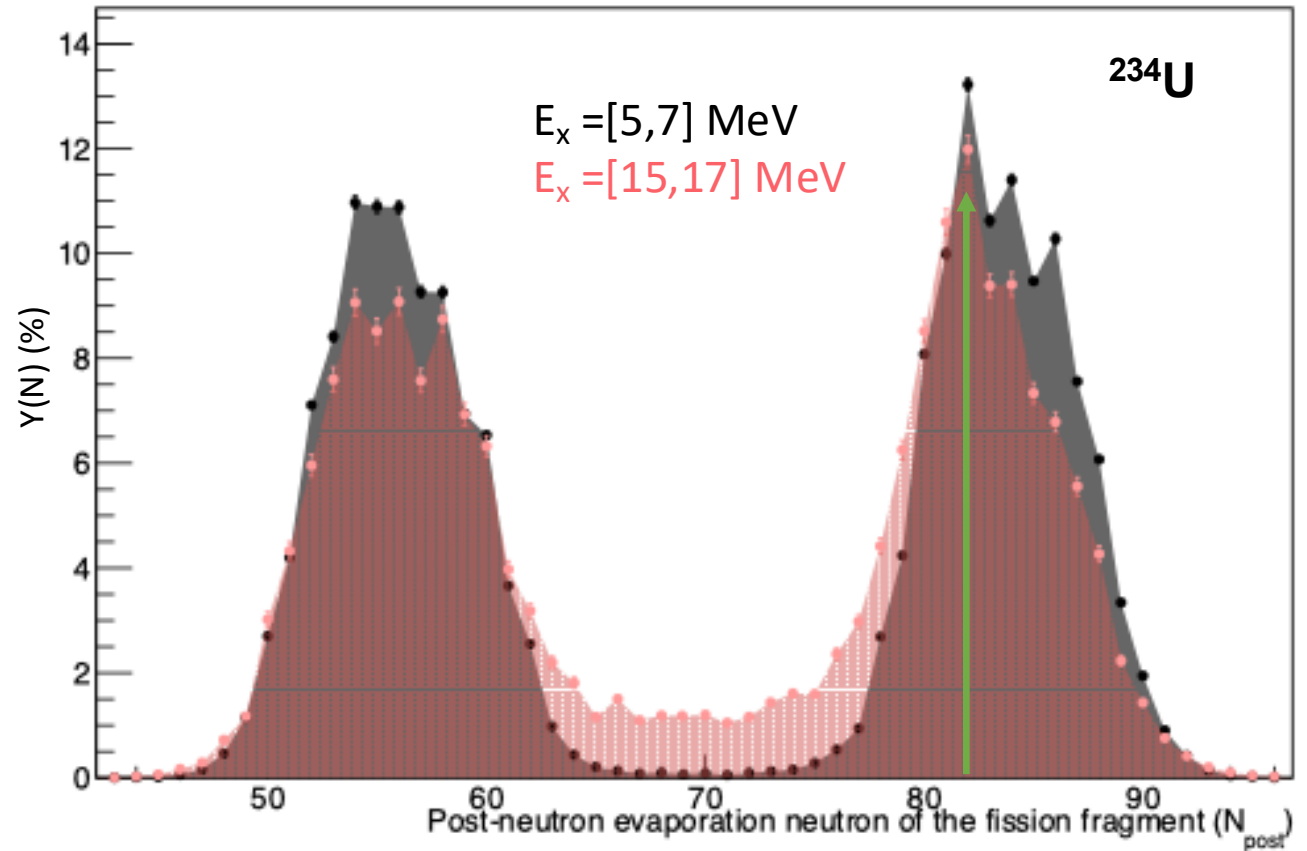

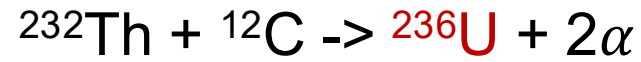

Kinematic Correlation of 2α in PISTA from ^8Be

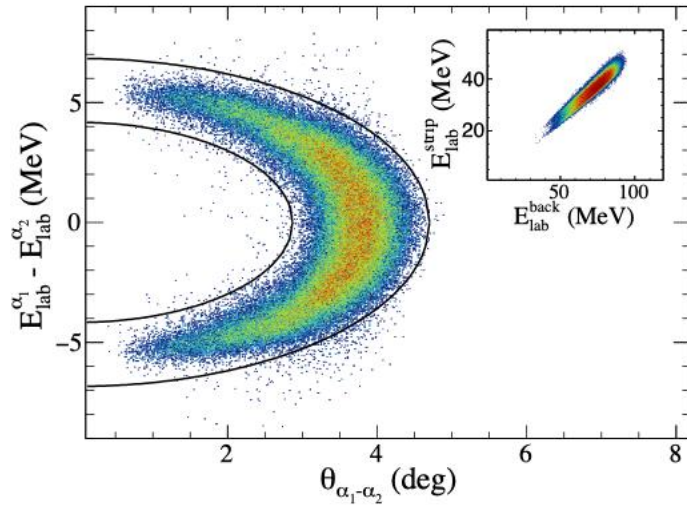

Fission probability of ^{236}U from 1α transfer

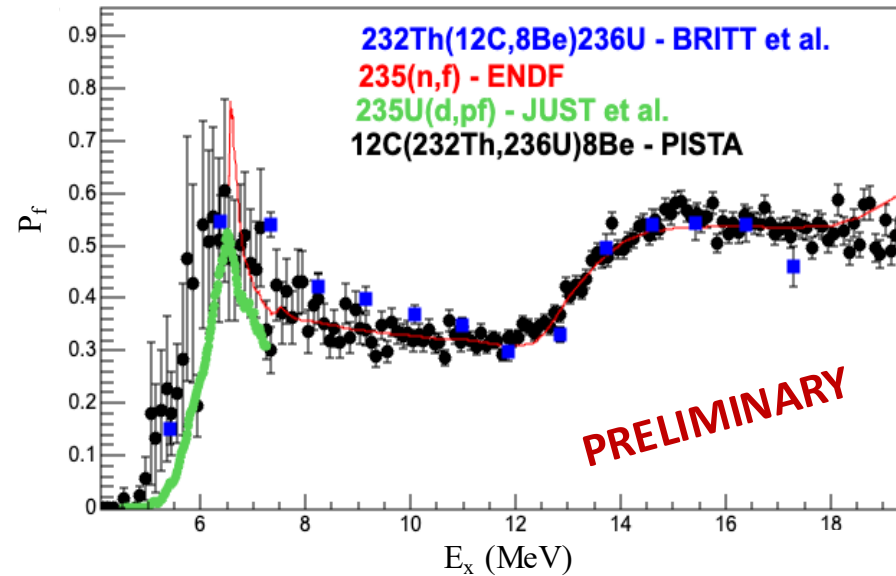

Excitation energy distribution of ^{236}U

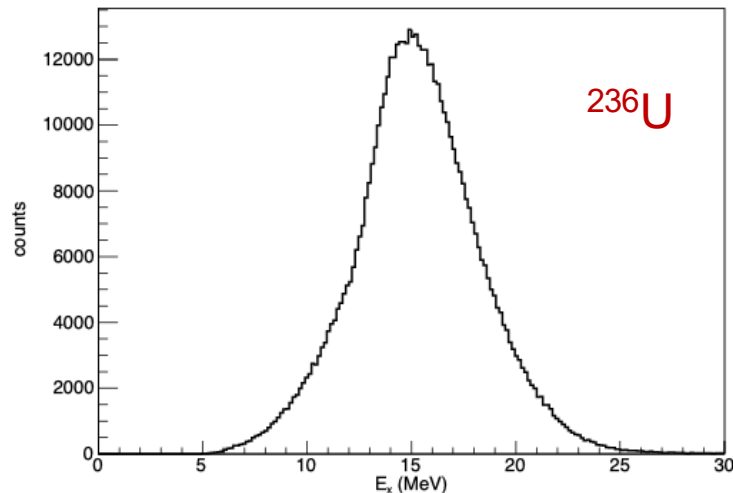

Isotopic Fission Yields UNDER ANALYSIS

New measurement performed this year:

- PISTA2 :

- Improved setup for 2α measurement
- Access to low E_x of ^{236}U

VAMOS



VAMOS++

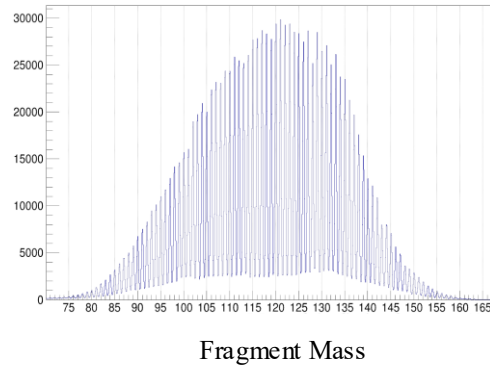
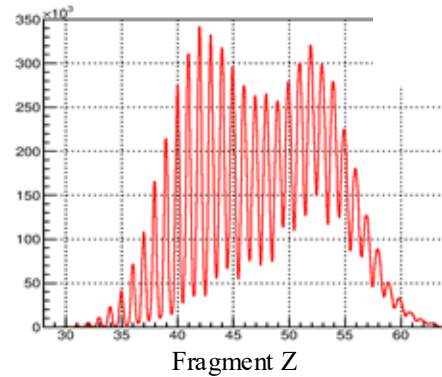
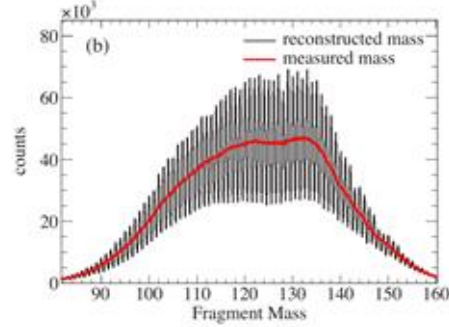
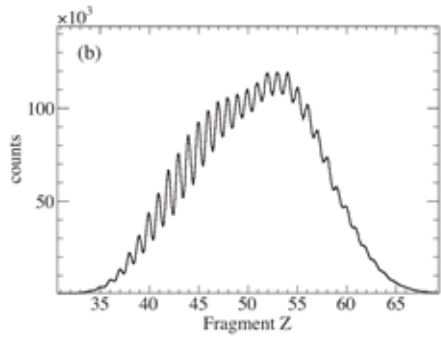

SPIDER



PISTA

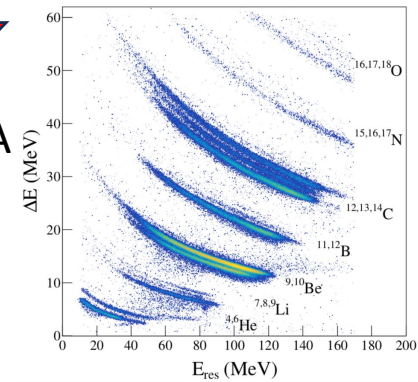
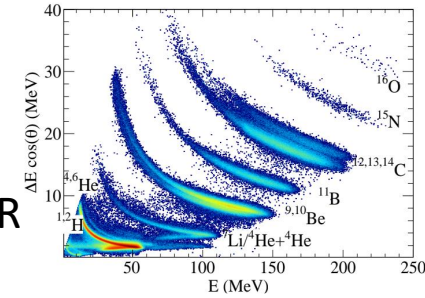

- The fission program at VAMOS/GANIL is a rich, very competitive, and a well established program providing experiment fission data for more than 10 years.
- The combination of inverse kinematics at Coulomb energies, a magnetic spectrometer, and complementary setups allows to study fission with a wide set of observables in a common setup.
- New and accurate observables and their correlations are now experimentally available.

Identification of ^{232}Th from ^{12}C

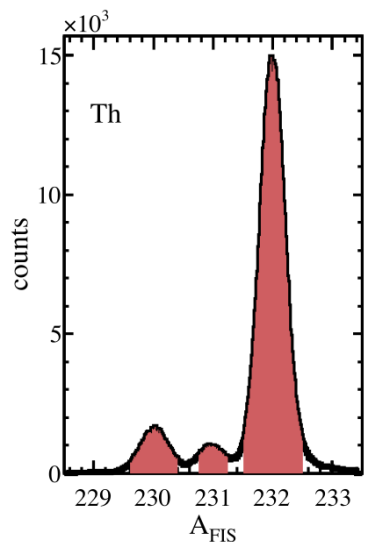

Excitation energy distribution of ^{232}Th

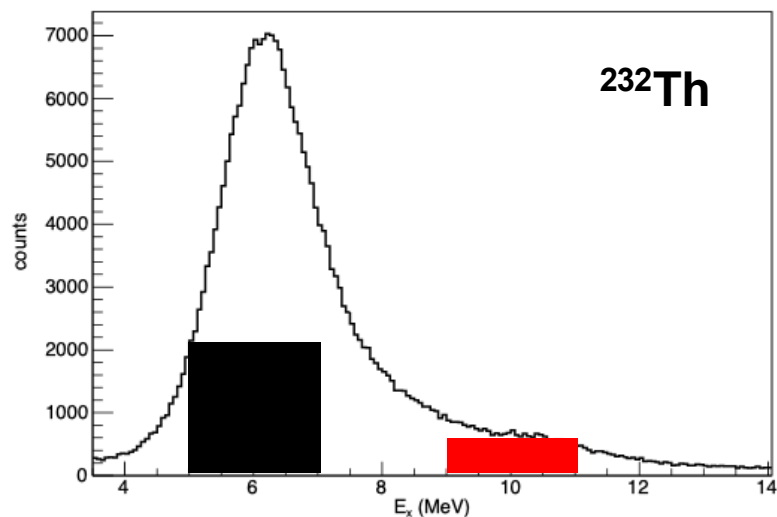

Elemental Fission Yields for two ranges of E_x

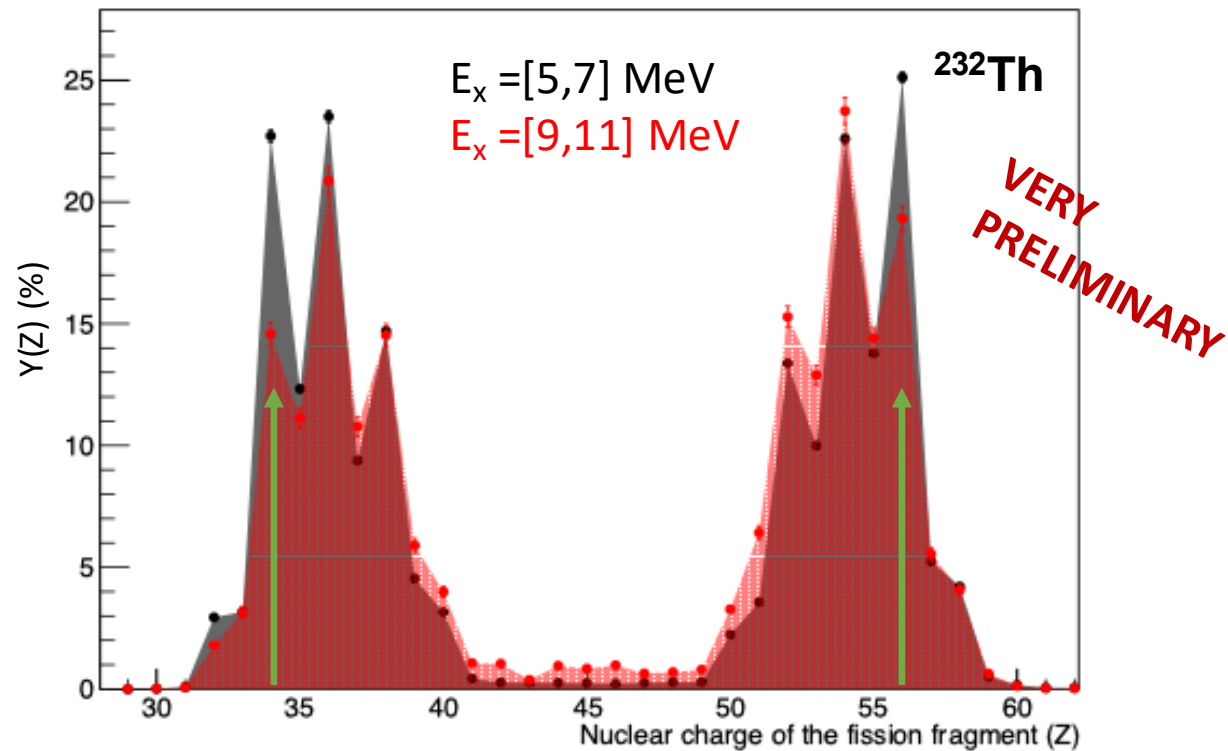

(Not Mirror Symmetry -> Transmission correction needed)

- Very asymmetric fission at low E_x
- $Z=34/56$ strongly suppressed by increasing E_x in 4 MeV