

Matrix Element Antennae in Hadron Decays

Fernando Abudinén, Giacomo Morgante, Peter Skands

FeynRules

[arXiv:1310.1921](https://arxiv.org/abs/1310.1921)

- Model of hadron decays using FeynRules
- Each hadron treated as an elementary particle
- Write out interaction lagrangians for each process
- Generate UFO file using Mathematica

```
LJpsi := -1/4 FS[Jpsi,mu,nu].FS[Jpsi,mu,nu] + 0.5 MJpsi^2 Jpsi[mu].Jpsi[mu];
```

```
LJpsiLep := NpCouple Jpsi[mu] lbar.Ga[mu].l;
```

```
LDKPiC := NpCouple I DN KPbar piC + HC[NpCouple I DN KPbar piC];
```

```
V[443] == {
  ClassName      -> Jpsi,
  SelfConjugate  -> True,
  Mass           -> {MJpsi,3.09692},
  Width          -> {WJpsi,9e-05},
  PropagatorLabel -> Jpsi,
  PropagatorType -> Straight,
  PropagatorArrow -> None,
  PDG            -> 443,
  ParticleName   -> "Jpsi",
  FullName       -> "J/psi"
},
```

```
S[101] == {
  ClassName      -> piC,
  SelfConjugate  -> False,
  Mass           -> {Mpi,0.13957},
  Width          -> {Wpi, 0},
  PropagatorLabel -> "SPS",
  PropagatorType -> Straight,
  PropagatorArrow -> None,
  QuantumNumbers -> {Q -> 1},
  PDG            -> 211,
  ParticleName   -> "pi+",
  AntiParticleName -> "pi-",
  FullName       -> "pion"
},
```

MadGraph

[arXiv:1405.0301](https://arxiv.org/abs/1405.0301)

- Use the VINCIA MadGraph plugin to generate files for matrix element corrections
- Plugin file is located using Vincia:mePlugin setting

```
import model Hadron_UF0_Test

generate d0 > k- pi+
add process d0 > k- pi+ a
add process d0 > k- pi+ a a
add process d0 > k- pi+ a a a
```

ME in Hadron Decays

- Use the matrix element as calculated by MadGraph plugin rather than VINCIA's process independent antenna function

$$a_{emit} = \frac{|M_{n+\gamma}|^2}{|M_n|^2}$$

$$s_{ij} = 2p_i \cdot p_j$$

$$\begin{aligned} a_{\text{Emit}}^{\text{FF}}(s_{ij}, s_{jk}, s_{ik}) &= 4 \frac{s_{ik}}{s_{ij}s_{jk}} - 4 \frac{m_i^2}{s_{ij}^2} - 4 \frac{m_k^2}{s_{jk}^2} + \delta_{if} \frac{2}{s_{IK}} \frac{s_{jk}}{s_{ij}} + \delta_{kf} \frac{2}{s_{IK}} \frac{s_{ij}}{s_{jk}} \\ &+ \delta_{iW} \frac{8}{3} \frac{1}{s_{ij}} \left(\frac{s_{jk}}{s_{IK} - s_{jk}} + \frac{s_{jk}(s_{IK} - s_{jk})}{s_{IK}^2} \right) \\ &+ \delta_{kW} \frac{8}{3} \frac{1}{s_{jk}} \left(\frac{s_{ij}}{s_{IK} - s_{ij}} + \frac{s_{ij}(s_{IK} - s_{ij})}{s_{IK}^2} \right) \end{aligned}$$

Antenna Plots

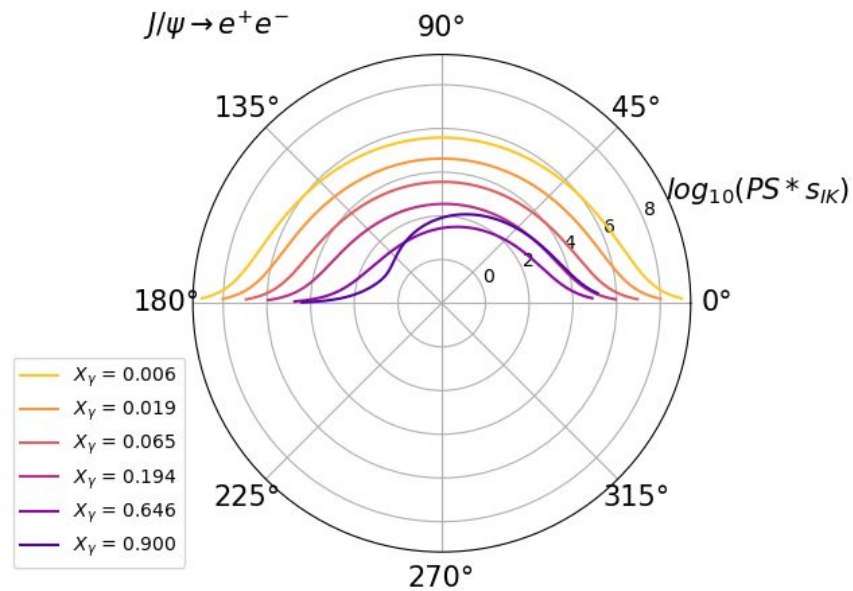
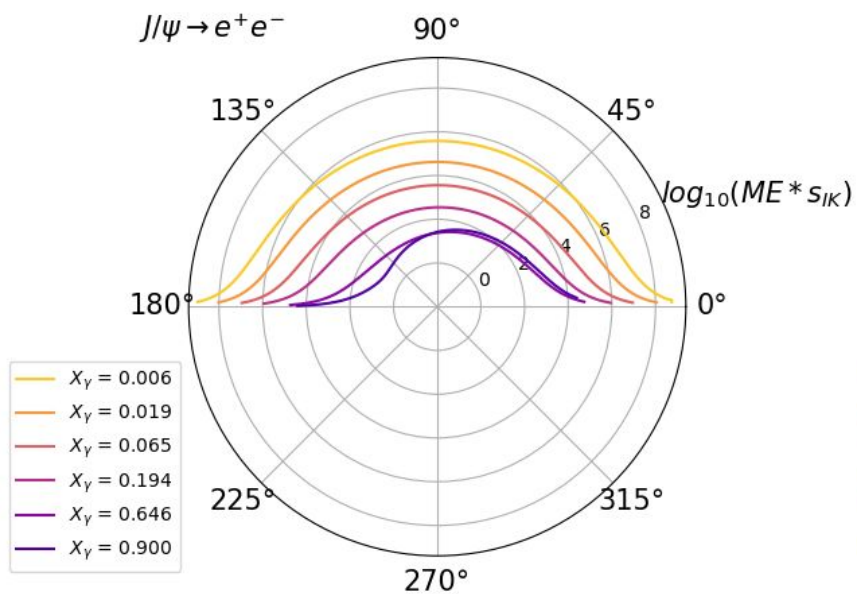

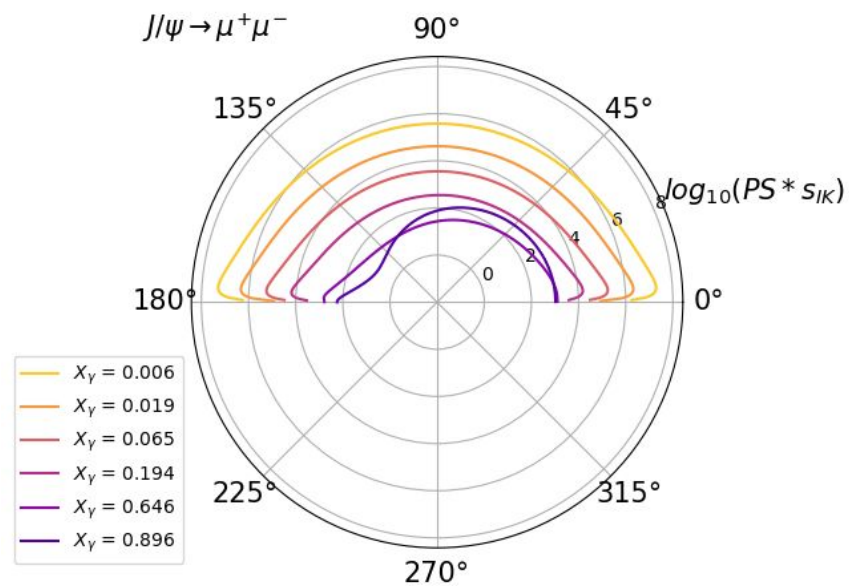
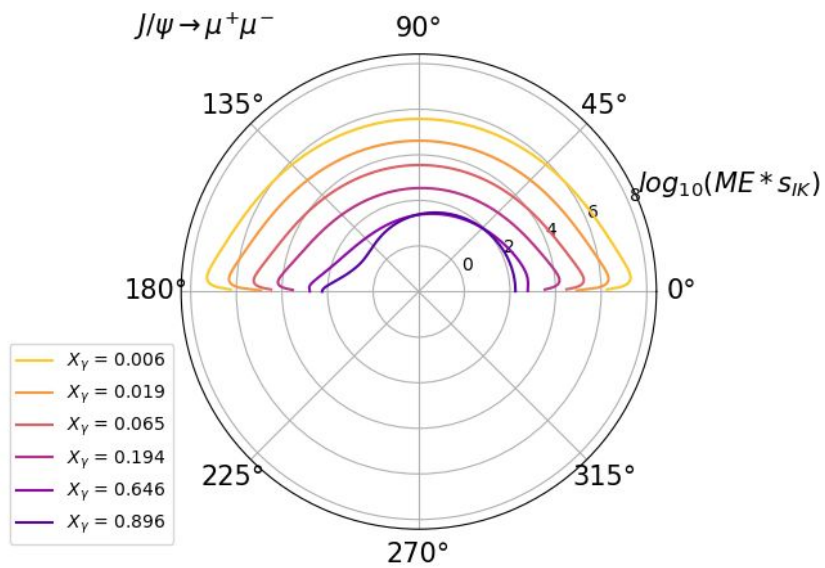

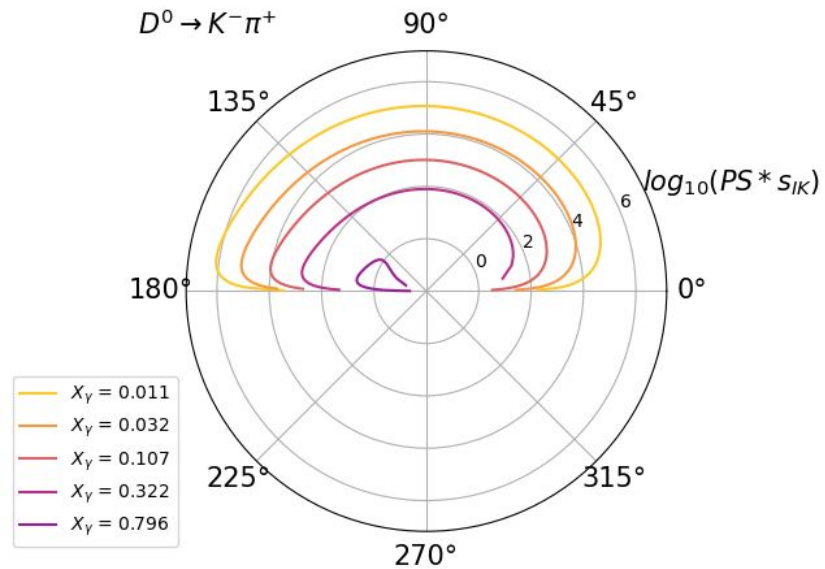
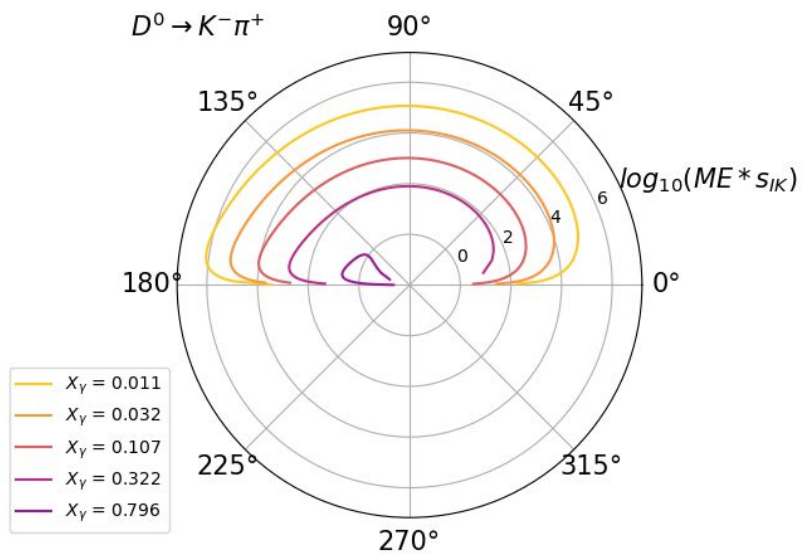

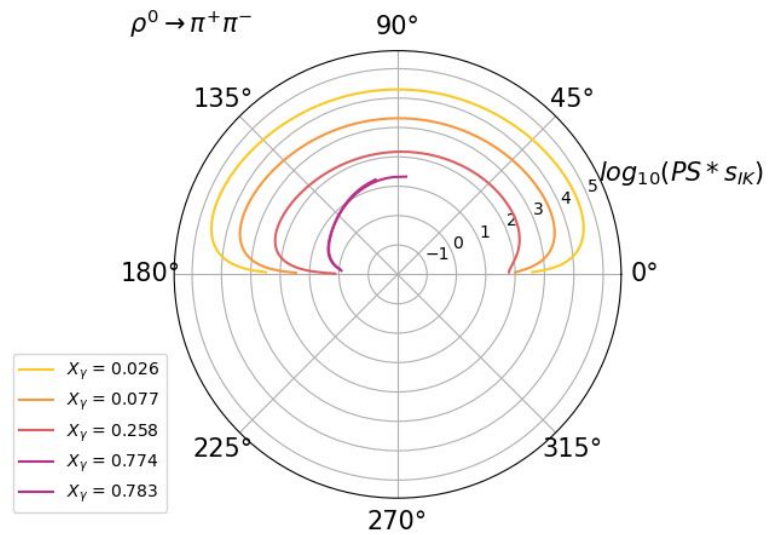
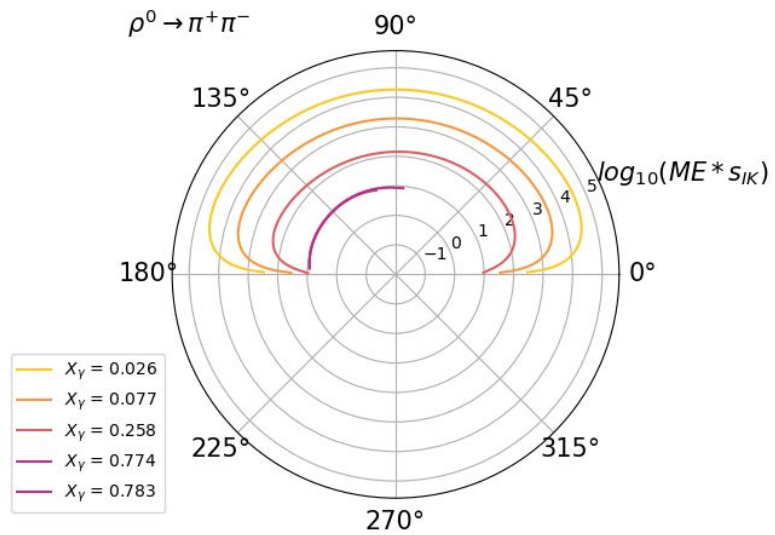

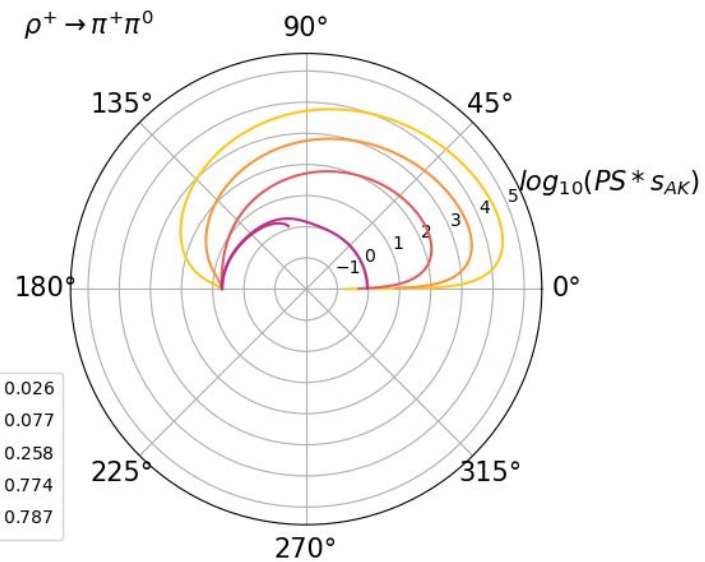
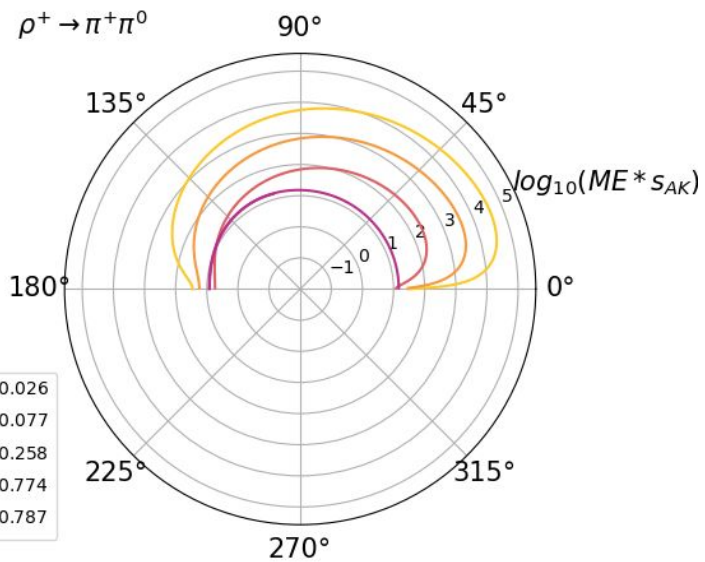

$B^+ \rightarrow K^+ \pi^0$

90°

135°

45°

$\log_{10}(ME * s_{AK})$

180°

0°

225°

315°

270°

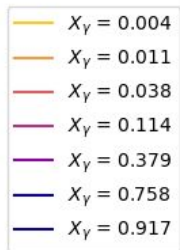

$B^+ \rightarrow K^+ \pi^0$

90°

135°

45°

$\log_{10}(PS * s_{AK})$

180°

0°

225°

315°

270°

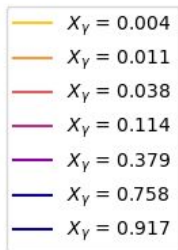

Limitations

- Works for very few processes
- Hopefully once we figure out general structure for each type of process can write a script to automatically generate processes
- Not validated at all for full multipole shower