

Quantum Cryptography, Tensor Networks, and the Python's Lunch

@ Theory Canada 17

Alex May, Sabrina Pasterski, **Chris Waddell**, and Michelle Xu

6 June 2025

Turing Meets Hawking: Complexity & Black Hole Physics

Recent studies of quantum black holes point to a surprising conclusion:

Violations of semi-classical physics can be produced by a sufficiently powerful quantum computer.

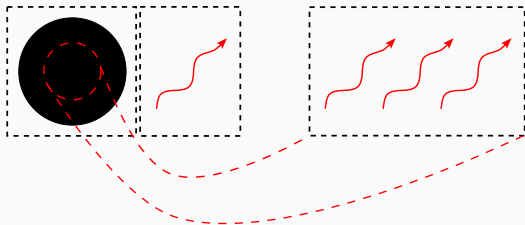

Ex: Extremely **high complexity** operations applied to early Hawking radiation from an old black hole can *instantaneously* manipulate its interior

[Harlow, Hayden '13], [Penington '19], [Almheiri, Engelhardt, Marolf, Maxfield '19], [Almheiri, Mahajan, Maldacena, Zhao '19], [Penington, Shenker, Stanford, Yang '19], [Almheiri, Hartman, Maldacena, Shaghoulian, Tajdini '19], [Kim, Tang, Preskill '20], [Akers, Engelhardt, Harlow, Penington, Vardhan '22]

The AdS/CFT Correspondence

Consistent theory of quantum gravity: **AdS/CFT** [Maldacena '97], [Witten '98], [Gubser, Klebanov, Polyakov '98]

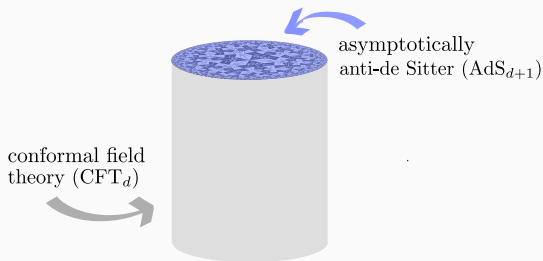

AdS:

- The **bulk** theory ($\text{dim} = d + 1$)
- Theory of **gravity**
- Fixed spacetime + \mathcal{H}_{QFT}

CFT:

- The **boundary** theory ($\text{dim} = d$)
- Theory **without gravity**
- \mathcal{H}_{CFT}

The **bulk-to-boundary map** is an isometric embedding $V : \mathcal{H}_{\text{QFT}} \rightarrow \mathcal{H}_{\text{CFT}}$

Tensor Networks and Gravity

Tensor networks (TNs) are very useful models for holographic states [Swingle '09]

- Modular construction which generalizes quantum circuits
- Unitaries replaced by more general tensors (often isometries)

Can be used to construct a **bulk-to-boundary map** $V : \mathcal{H}_{\text{bulk}} \rightarrow \mathcal{H}_{\text{bdy}}$

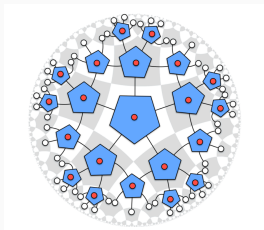

- Red dots = tensor factors of input $\mathcal{H}_{\text{bulk}}$
- White dots = tensor factors of output \mathcal{H}_{bdy}
- Blue boxes = tensors
- Black lines = input/output to tensors ($\text{dim} = D$)

Particularly good model for holography: **(Haar) random tensors** [Hayden et al. '16]



Tensor Networks and Gravity: Information Theoretic Properties

Some important features of AdS/CFT with avatars in TNs:

- The **Ryu-Takayanagi (RT) formula** [Ryu, Takayanagi '06], [Hubeny, Rangamani, Takayanagi '07], [Wall '12],

[Lewkowycz, Maldacena '13], [Faulkner, Lewkowycz, Maldacena '13], [Engelhardt, Wall '14]

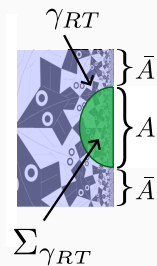

$$S(\rho_A) = \frac{1}{4G} \times \text{Area}[\gamma_{RT}]$$

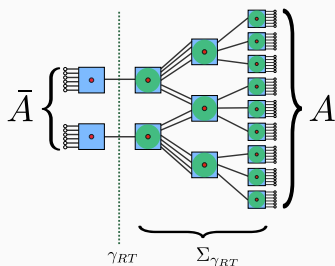

$$S_2(\rho_A) \leq \log(D) \times |\gamma_{RT}|$$

Shaded green region $\Sigma_{\gamma_{RT}}$: The **entanglement wedge**

Tensor Networks and Gravity: Information Theoretic Properties

Some important features of AdS/CFT with avatars in TNs:

- **Entanglement wedge (EW) reconstruction** [Hamilton, Kabat, Lifschytz, Lowe '06], [Czech, Karczmarek, Nogueira, Van Raamsdonk '12], [Headrick, Hubeny, Lawrence, Rangamani '14], [Jafferis, Lewkowycz, Maldacena, Suh '15]

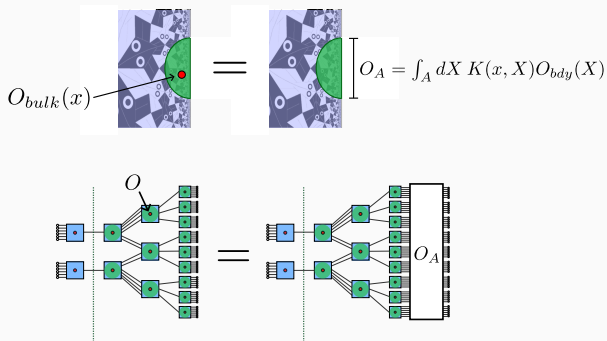

For all $O \in \mathcal{B}(\Sigma_{\gamma_{RT}})$, exists $O_A \in \mathcal{B}(A)$ such that $VO|\psi\rangle_{bulk} = O_A V|\psi\rangle_{bulk}$

Tensor Networks and Gravity: Complexity Theoretic Properties

What about *computational* aspects of bulk reconstruction?

- The EW can contain a bulge called a **python's lunch** [Brown, Gharibyan, Penington, Susskind '19]
- Complexity depends on the number of **post-selections** m_R
- For O in the lunch, reconstruction O_A has **circuit complexity** $\mathcal{C} \sim 2^{m_R/2}$

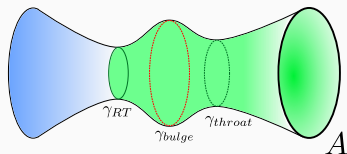
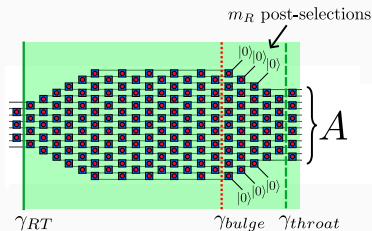

Geometrical analogue: The **python's lunch conjecture (PLC)**

$$\ln \mathcal{C} = \frac{1}{2} \left(\frac{\text{Area}[\gamma_{bulge}] - \text{Area}[\gamma_{throat}]}{4G} \right) + O(G^0)$$

Goal: Look for direct evidence of the PLC in gravity

Result 1: Learning about the Lunch with Low Complexity

The python's lunch conjecture states that we can't learn much about the lunch with low complexity operations, but we can learn *something*

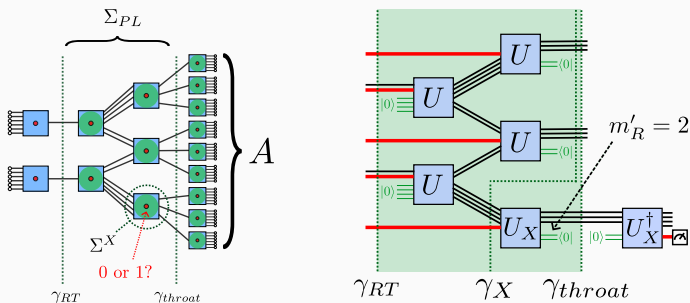

To estimate the bulk state on a subspace $\Sigma^X \subseteq \Sigma_{pL}$ from the boundary state:

- Identify the cut γ_X "to the left" of Σ^X which minimizes the number of projections m'_R in the restricted tensor network $V_X : \mathcal{H}_{\gamma_X} \otimes \mathcal{H}_{\Sigma_{\gamma_X}} \rightarrow \mathcal{H}_{\gamma_{throat}}$
- Inverting the TN up to the cut γ_X and then measuring, the success probability has exponentially small bias

$$\delta \sim 2^{-m'_R}$$

Result 1: Learning about the Lunch with Low Complexity

Gravity analogue:

- Let $X \subseteq \Sigma_{\text{PL}}$ be the subset we would like to reconstruct
- The analogue of the TN cut γ^X is a “restricted bulge” surface γ_{bulge}^X
- The restricted bulge is just the bulge with respect to smaller $\Sigma^X \subset \Sigma_{\text{PL}}$ containing X
- The geometric analogue of m'_R is then

$$\frac{\Delta A_X}{4G} \equiv \frac{\text{Area}[\gamma_{\text{bulge}}^X] - \text{Area}[\gamma_{\text{throat}}]}{4G}$$

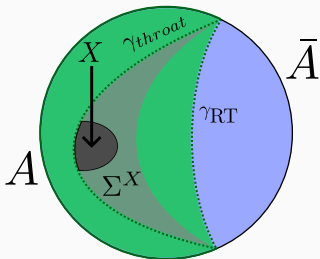

- Bias for sub-exponential complexity reconstruction: $\ln(1/\delta) = \frac{\Delta A_X}{4G}$

Result 2: A geometrical conjecture for holographic spacetimes

We can make this into a purely geometrical conjecture via a cryptographic primitive called (computationally secure) **conditional disclosure of quantum secrets (CDQS)** [Allerstorfer et al. '23]

Alice and Bob, who **cannot communicate** with each other, must nonetheless coordinate to either **reveal or conceal** a secret message $|q\rangle$ to/from a computationally bounded referee, depending on the inputs x, y they independently receive

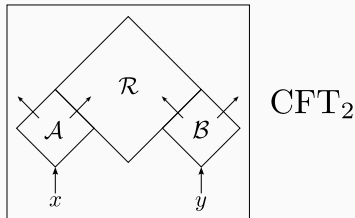

We show that this requires Alice and Bob to share correlation

$$I(\mathcal{A} : \mathcal{B}) > \log(1/\delta + \dots)$$

where δ is the bias for the referee to correctly guess the message using low complexity operations in instances (x, y) when the message should be concealed

Result 2: A geometrical conjecture for holographic spacetimes

Embedding this set-up in a holographic CFT, we can argue that CDQS is possible from the bulk point of view whenever

$$J_{2 \rightarrow 2} \equiv J^+[\text{EW}(\mathcal{A})] \cap J^+[\text{EW}(\mathcal{B})] \cap J^-[\text{PL}(\mathcal{R})] \cap J^-[\text{EW}(\mathcal{R}) \setminus \text{PL}(\mathcal{R})] \neq \emptyset$$

The information x, y and $|q\rangle$ can then causally propagate to a bulk point and be compared, and then $|q\rangle$ can be sent either to the “easy” or “hard” to reconstruct regions for \mathcal{R}

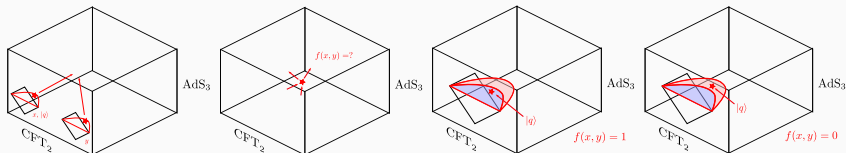

Using the conjecture $\ln(1/\delta) = \frac{\Delta A_X}{4G}$ for low-complexity reconstruction by \mathcal{R} , we then obtain the following geometric constraint on holographic spacetimes:

$$J_{2 \rightarrow 2} \neq \emptyset \implies I(\mathcal{A} : \mathcal{B}) \geq \alpha_0 \frac{\Delta A_X}{4G}, \quad \alpha_0 \text{ universal}$$

where $I(\mathcal{A} : \mathcal{B}) = S(\mathcal{A}) + S(\mathcal{B}) - S(\mathcal{A} \cup \mathcal{B})$ can be computed by the Ryu-Takayanagi formula

Result 2: A geometrical conjecture for holographic spacetimes

Various pieces of evidences:

1. **Parametric:** We show that $J_{2 \rightarrow 2} \neq \emptyset$ implies $I(\mathcal{A} : \mathcal{B}) = O(1/G)$
2. **Weaker lower bound:** We identify a subset $Y \subset X$ such that

$$I(\mathcal{A} : \mathcal{B}) \geq \frac{1}{2} \left(\frac{\text{Area}[\gamma_{\text{bulge}}^Y] - \text{Area}[\gamma_{\text{throat}}]}{4G} \right)$$

3. **Stronger lower bound is false:** We study concrete examples of asymptotically AdS_3 spacetimes, showing that the lower bound holds whereas the stronger lower bound

$$I(\mathcal{A} : \mathcal{B}) \stackrel{?}{\geq} \alpha_0 \left(\frac{\text{Area}[\gamma_{\text{bulge}}] - \text{Area}[\gamma_{\text{throat}}]}{4G} \right) = \alpha_0 \ln \mathcal{C}$$

does not. If the python's lunch is true, then $I(\mathcal{A} : \mathcal{B})$ is not lower bounded by the log of the maximum complexity \mathcal{C} of the referee.

Items (1), (2) are proven using the **focusing theorem** (inspired by [May, Penington, Sorce])

Conclusions

The complexity of decoding Hawking radiation, or more general holographic encodings of spacetime, is an important open question, and existing proposals deserve closer scrutiny

To this end, we:

- Derive new conclusions regarding the impact of post-selection for **low-complexity bulk reconstruction in TNs**
- Extrapolate these conclusions to **genuine gravitational theories** (following the reasoning of the PLC)
- Prove **new lower bounds on the correlation** required to complete a cryptographic scheme called CDQS
- Combine these arguments to formulate a fully **geometrical constraint** on holographic spacetimes
- Provide various avenues of **circumstantial evidence** for this proposal