

Conceptual design for horizontal insertion of FLArE TPC modules

L. Bartoszek

BARTOSZEK ENGINEERING

4/22/24

Overview

- There isn't enough room in the current tunnel for a vertical insertion of FLArE TPC modules
- Horizontal insertion of TPC modules has been done before—EXO
 - EXO was a vacuum insulated cryostat with two copper vessels made from ultra radiopure copper
 - The inner cryostat (surrounding the LXe TPC,) was full of HFE, a heat transfer hydrocarbon liquid
 - I designed a custom machine supported from the room crane rails in the clean room at WIPP to do the insertion
- EXO is also where I got the idea to use Jetseals to seal the TPC modules against the vessel
- The insulation scheme is similar to MicroBooNE

From a talk I gave at EXO Week in 2009:

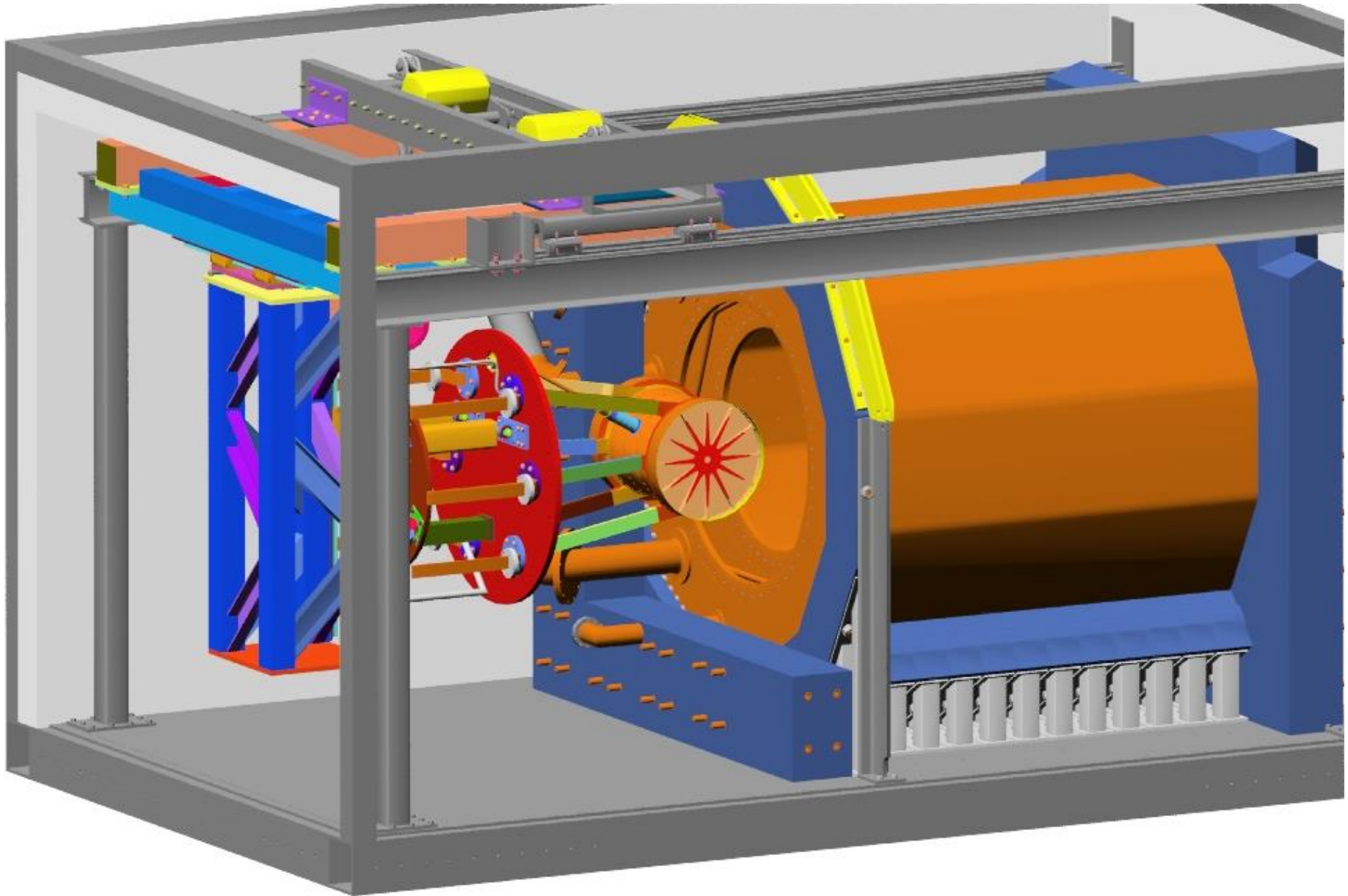

The TPC was supported by a custom horizontal insertion mechanism

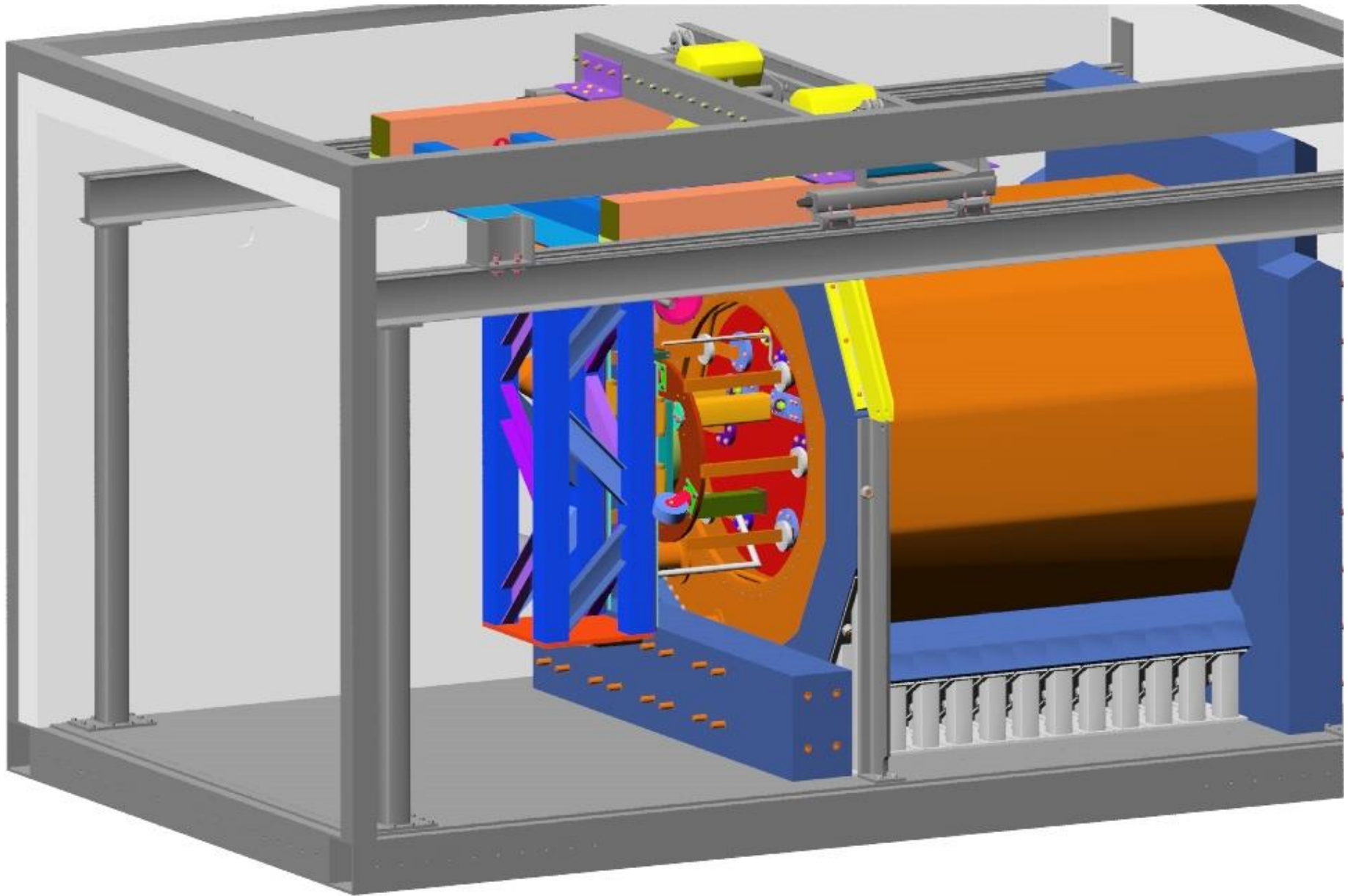

The cold door mated against the inner cryostat

The TPC and the cold door supported from the installation machine

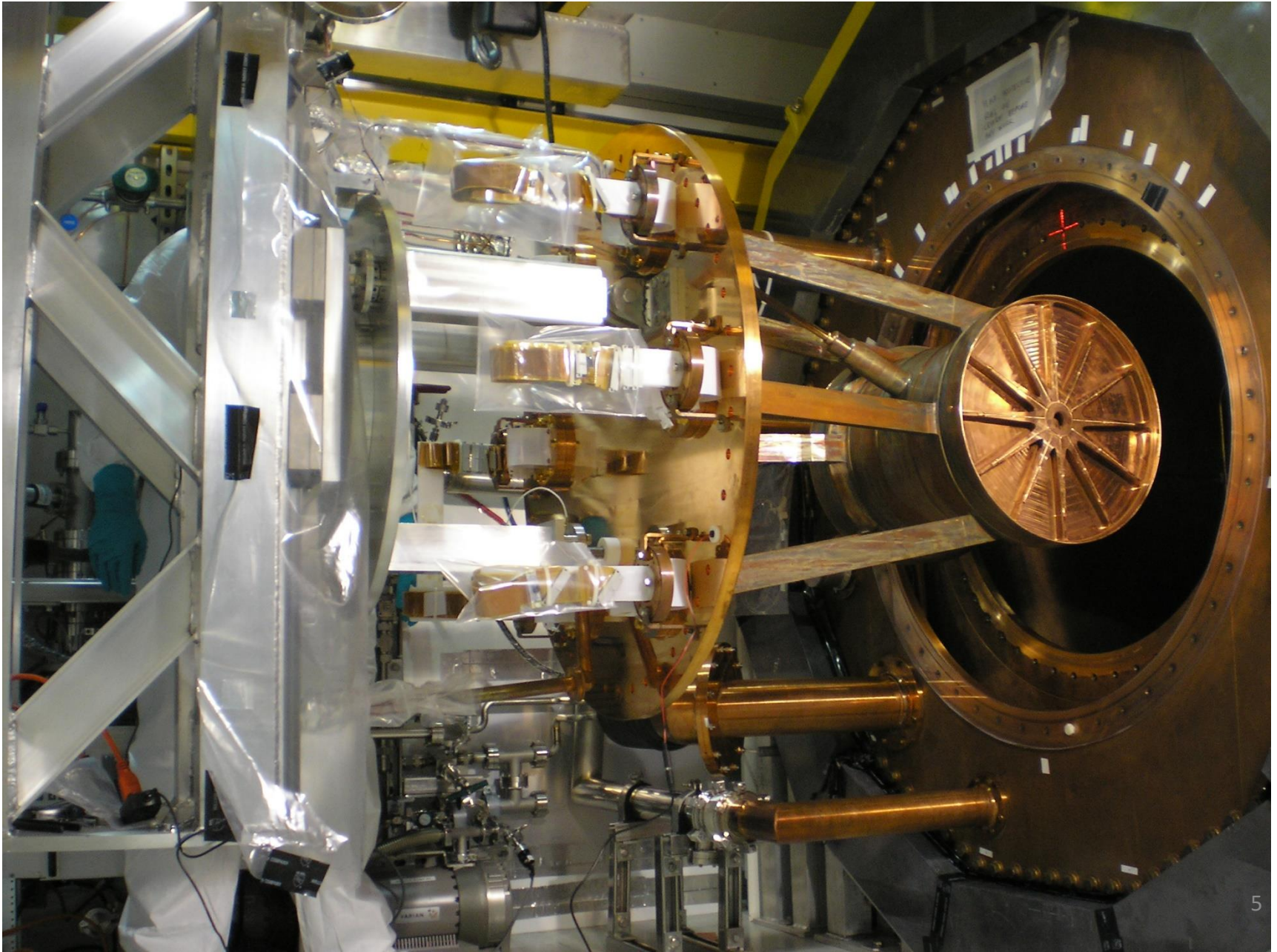

The installation machine holding the outer warm door

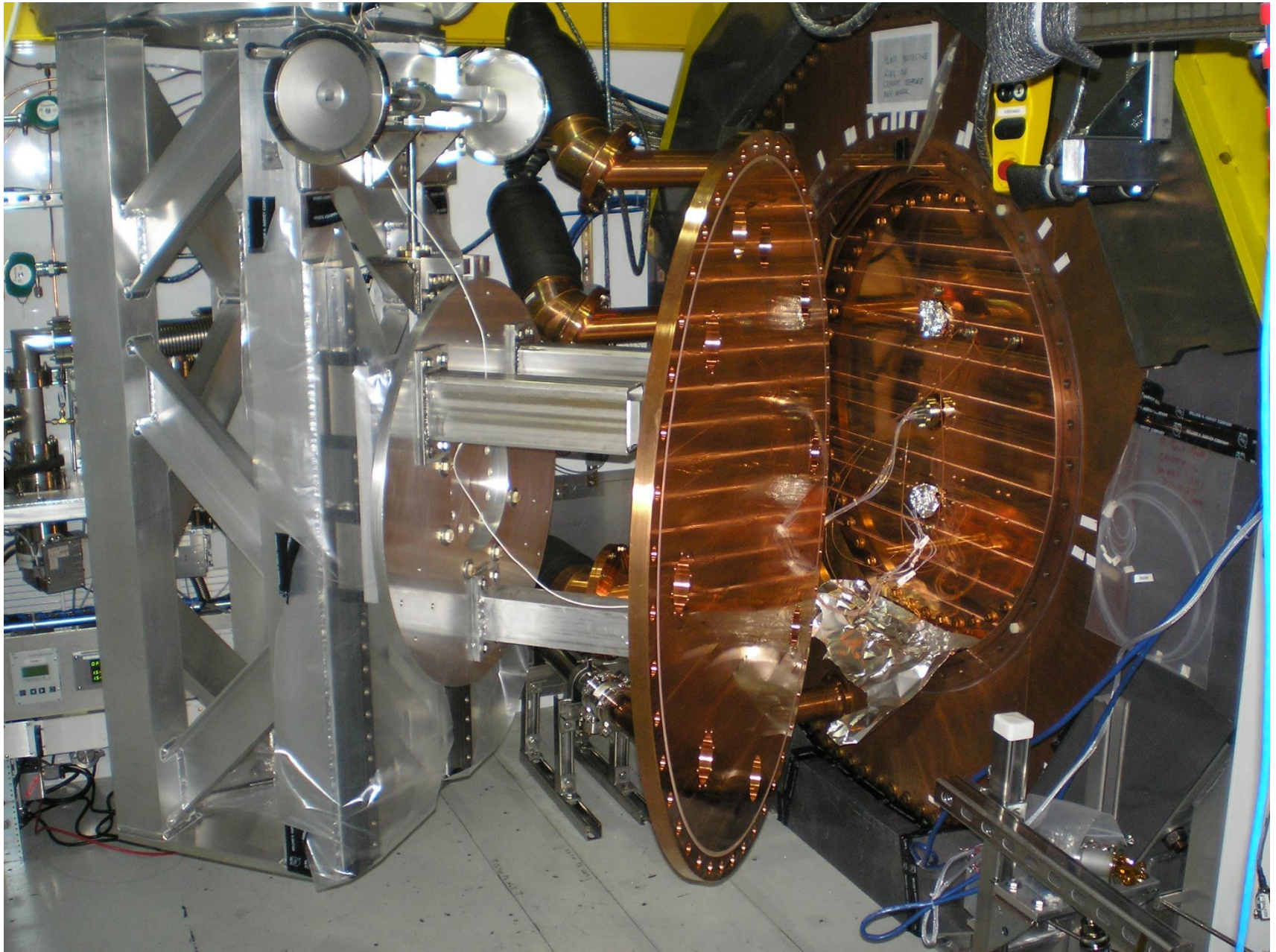

Two views of the HV feedthrough through the cold door

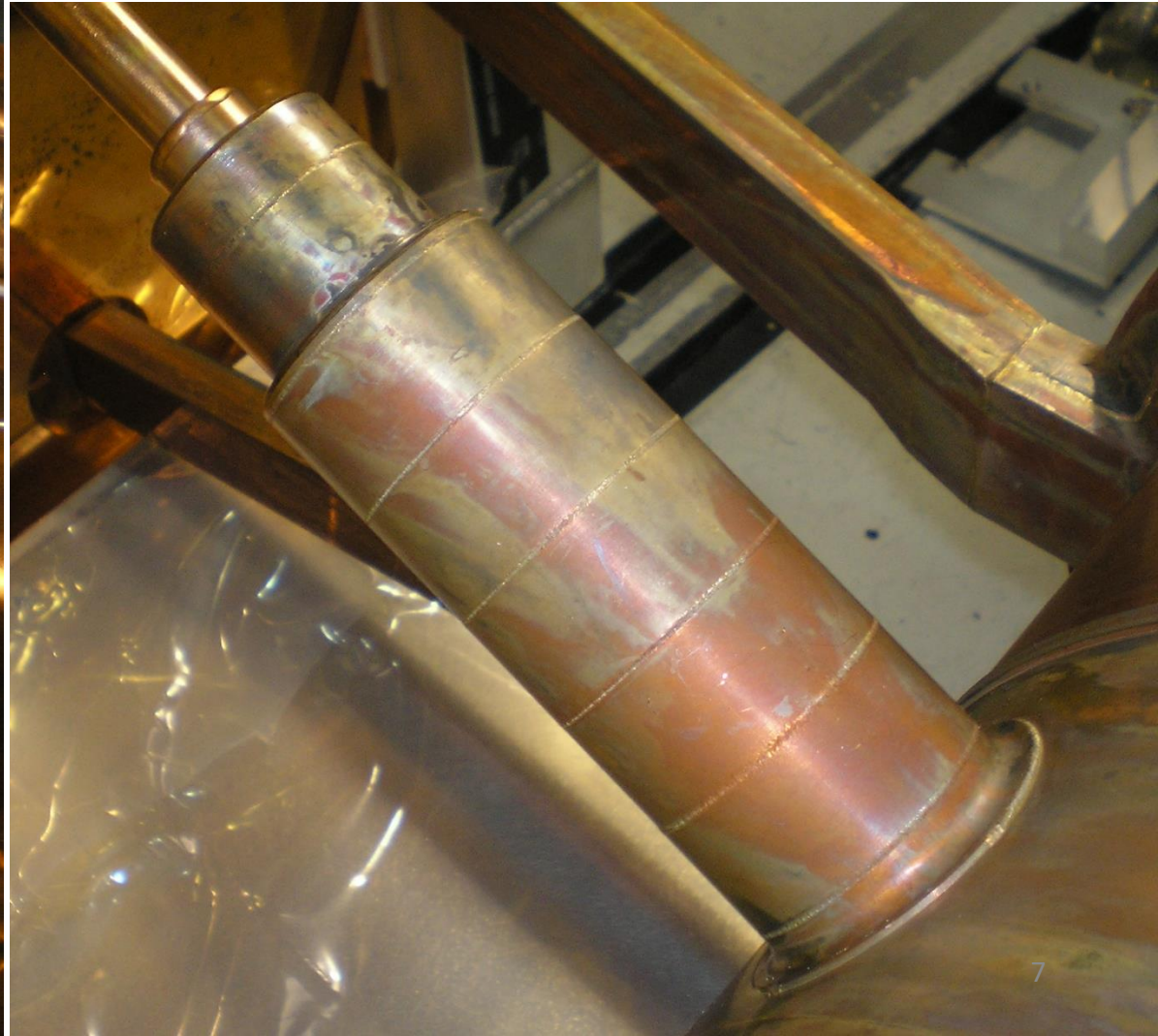
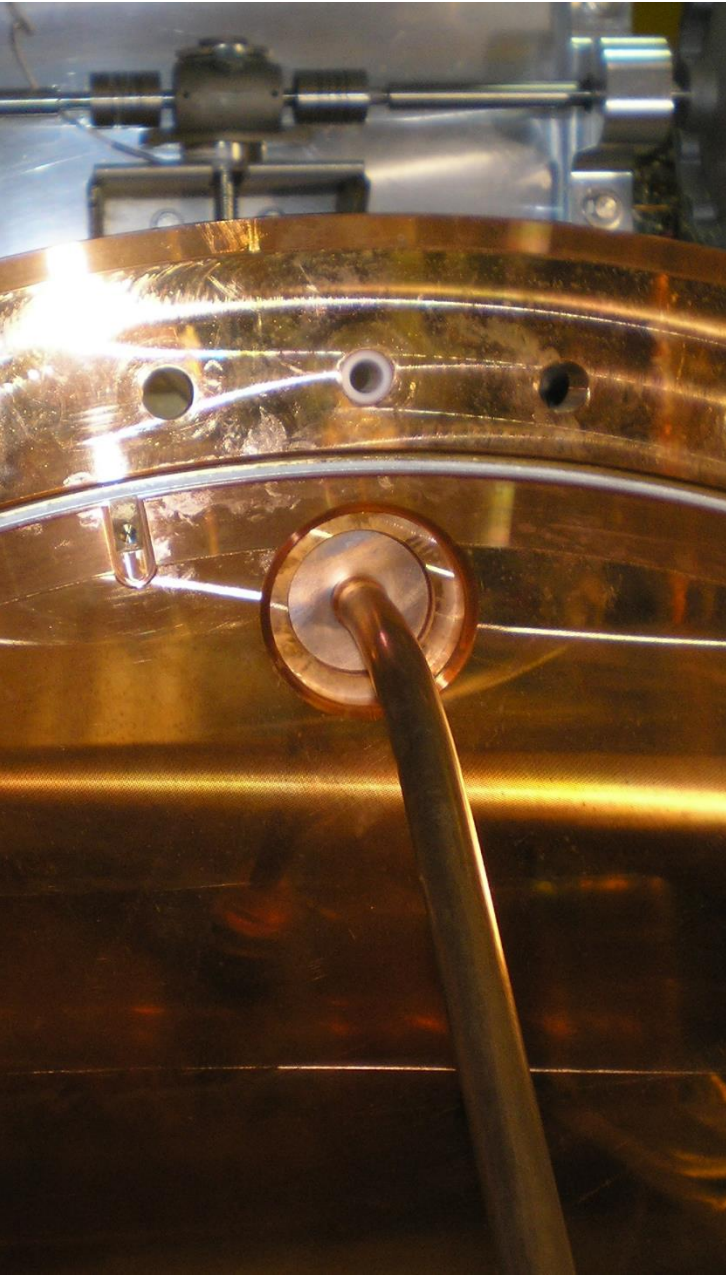

The fully insulated detector in the tunnel at CERN

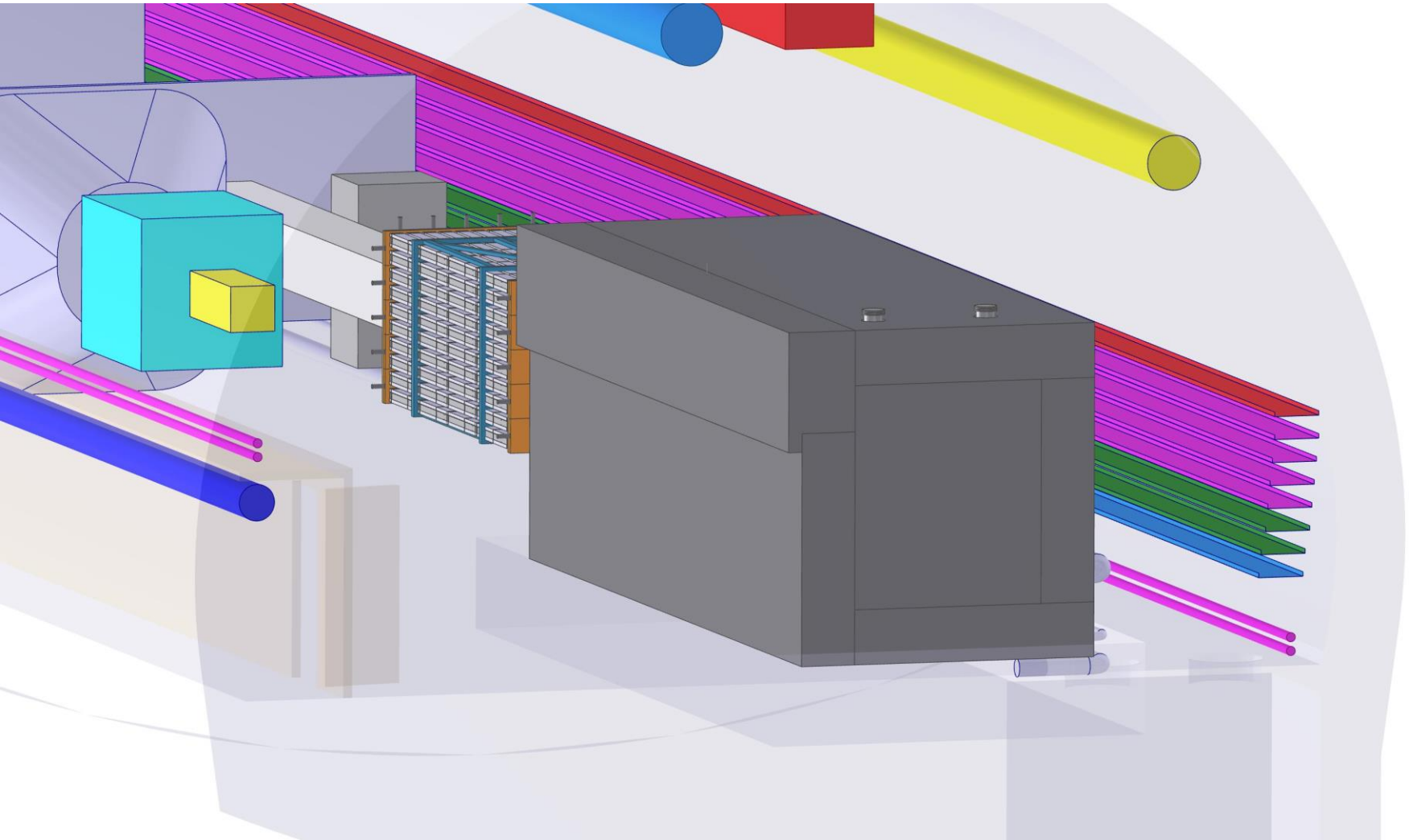

Removing the front face foam to expose the cold doors of the detector

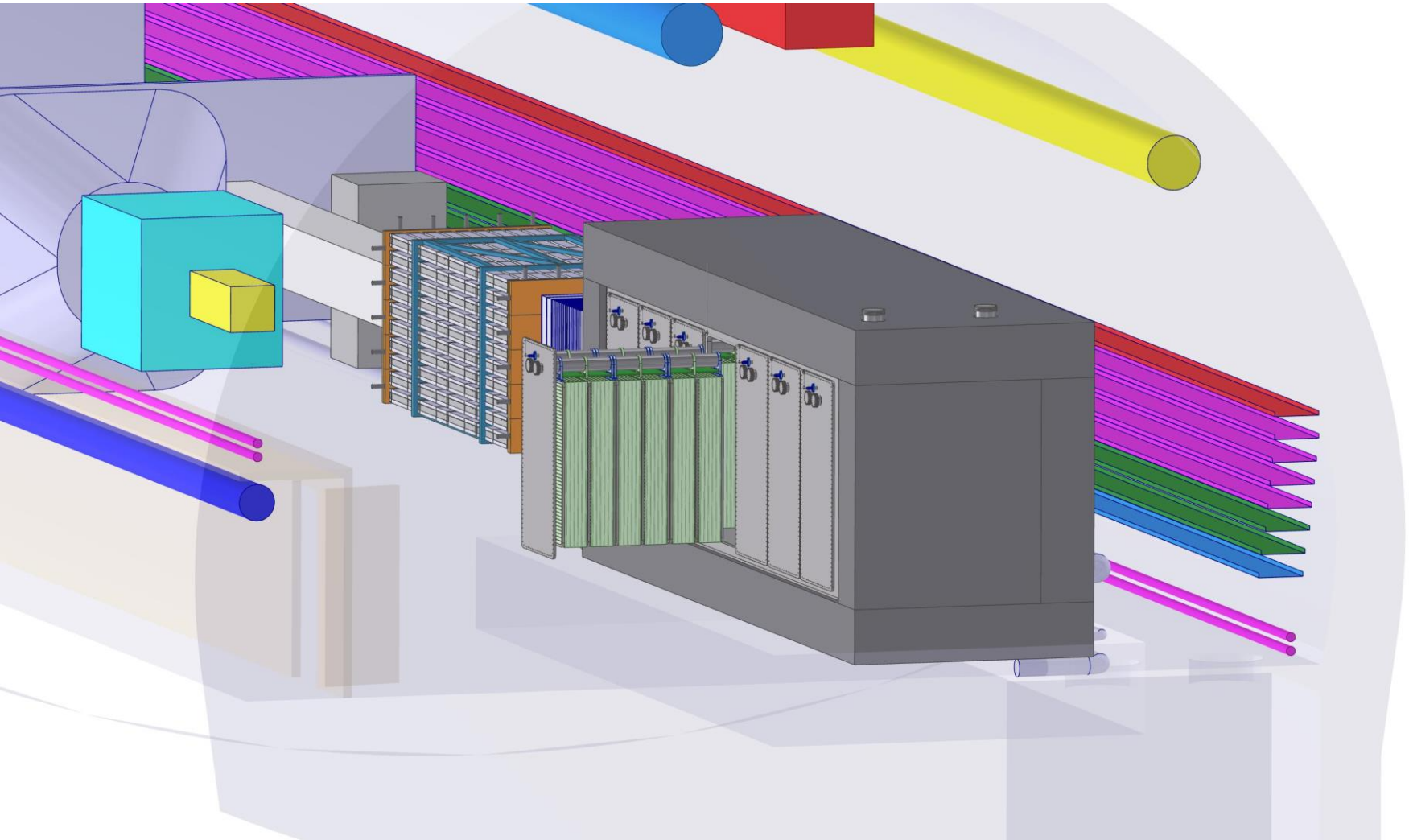

End view showing ample room for a TPC module insertion machine

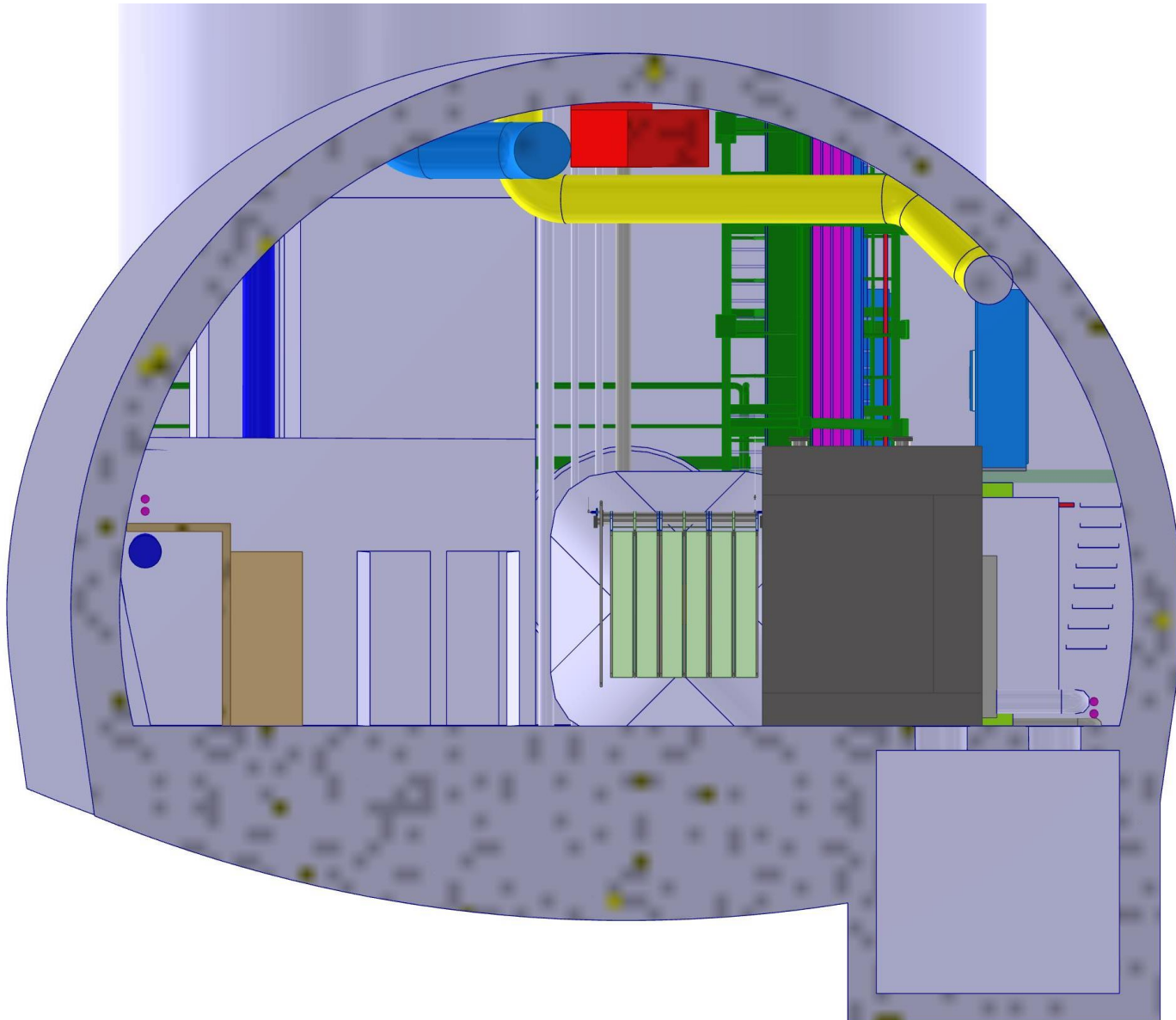

Cryostat surrounded by rigid foam

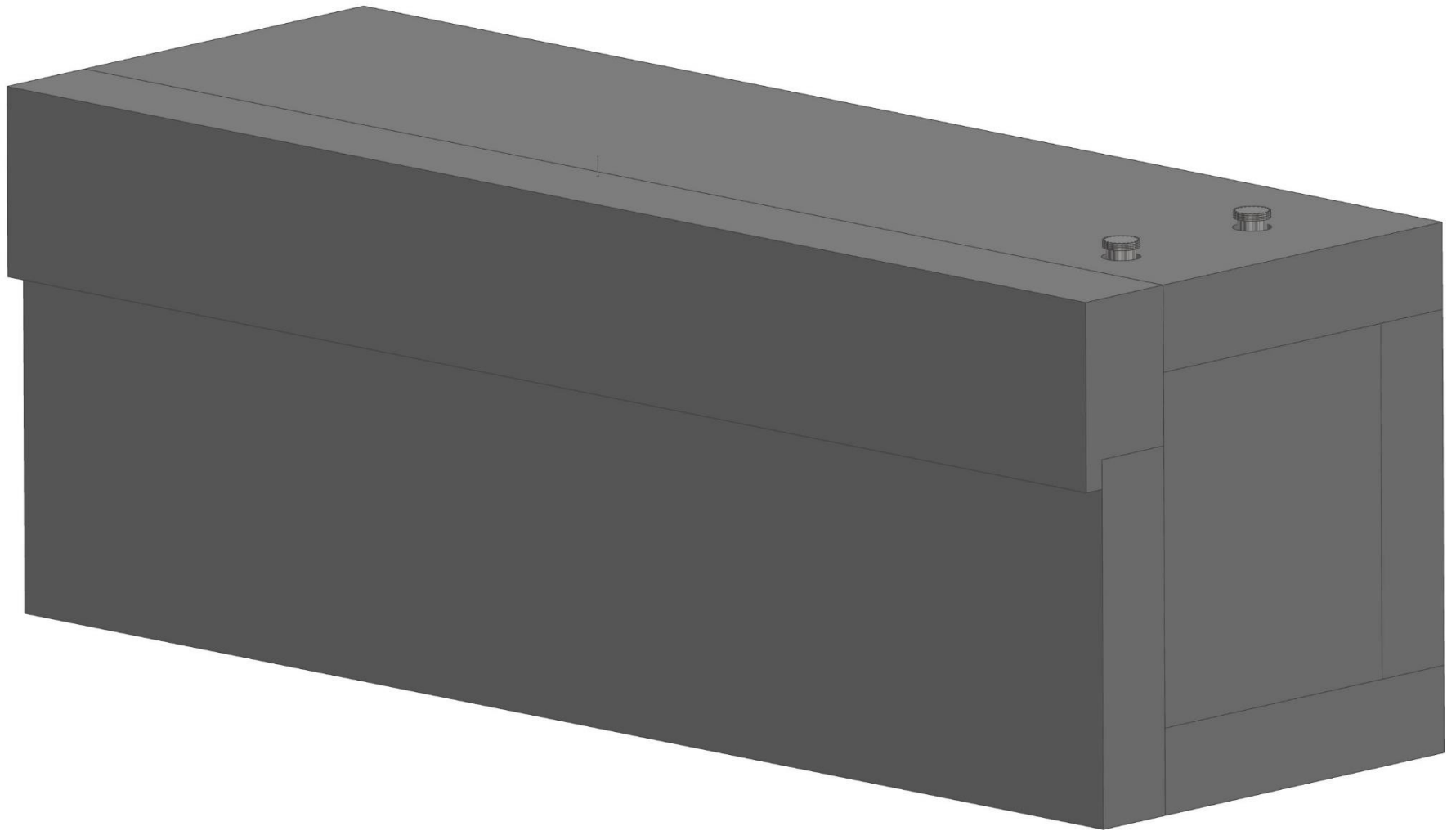

First piece of foam removed exposing the feedthroughs

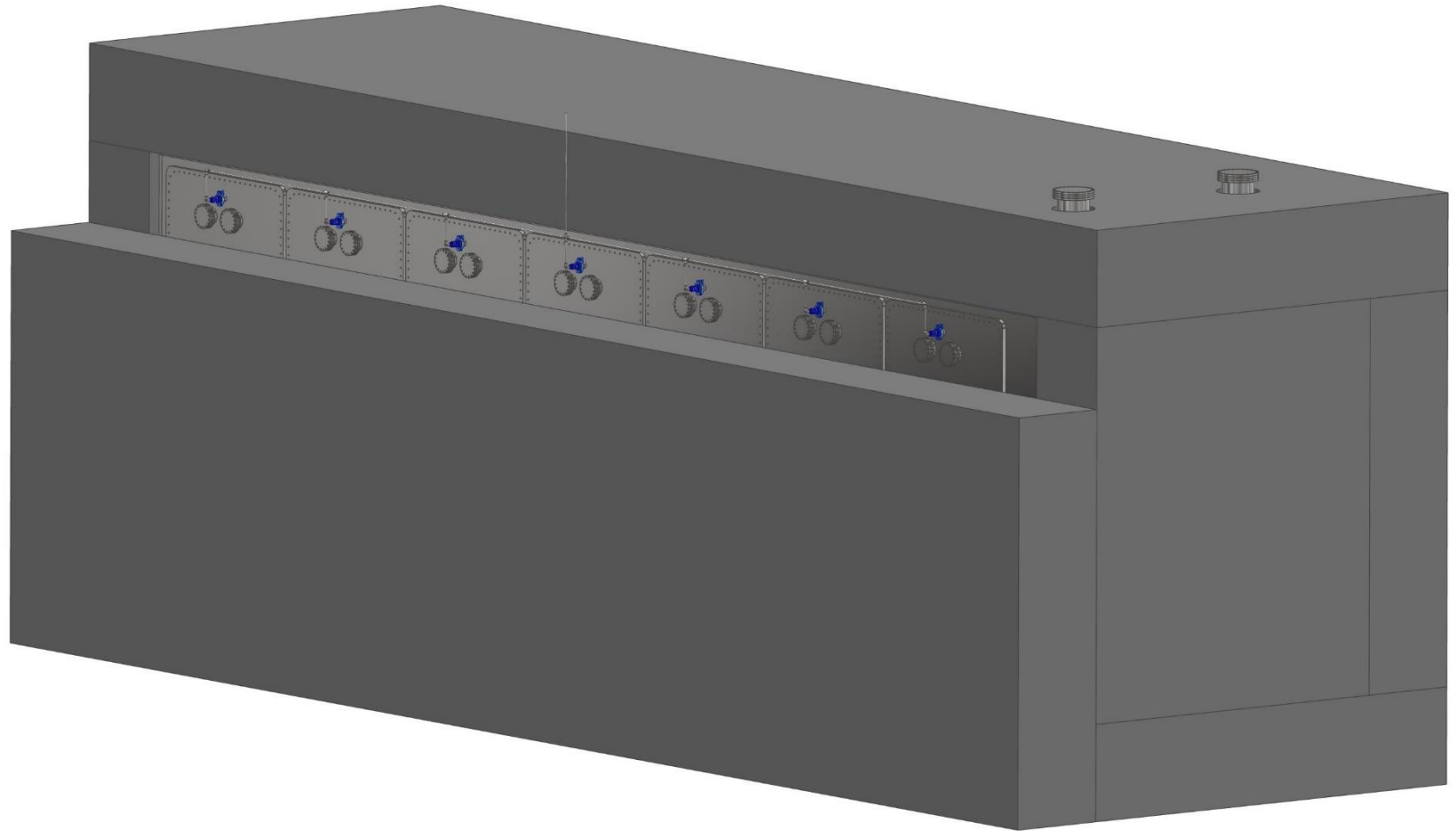

Front face foam removed in preparation for module extraction



A TPC module withdrawn horizontally from the cryostat

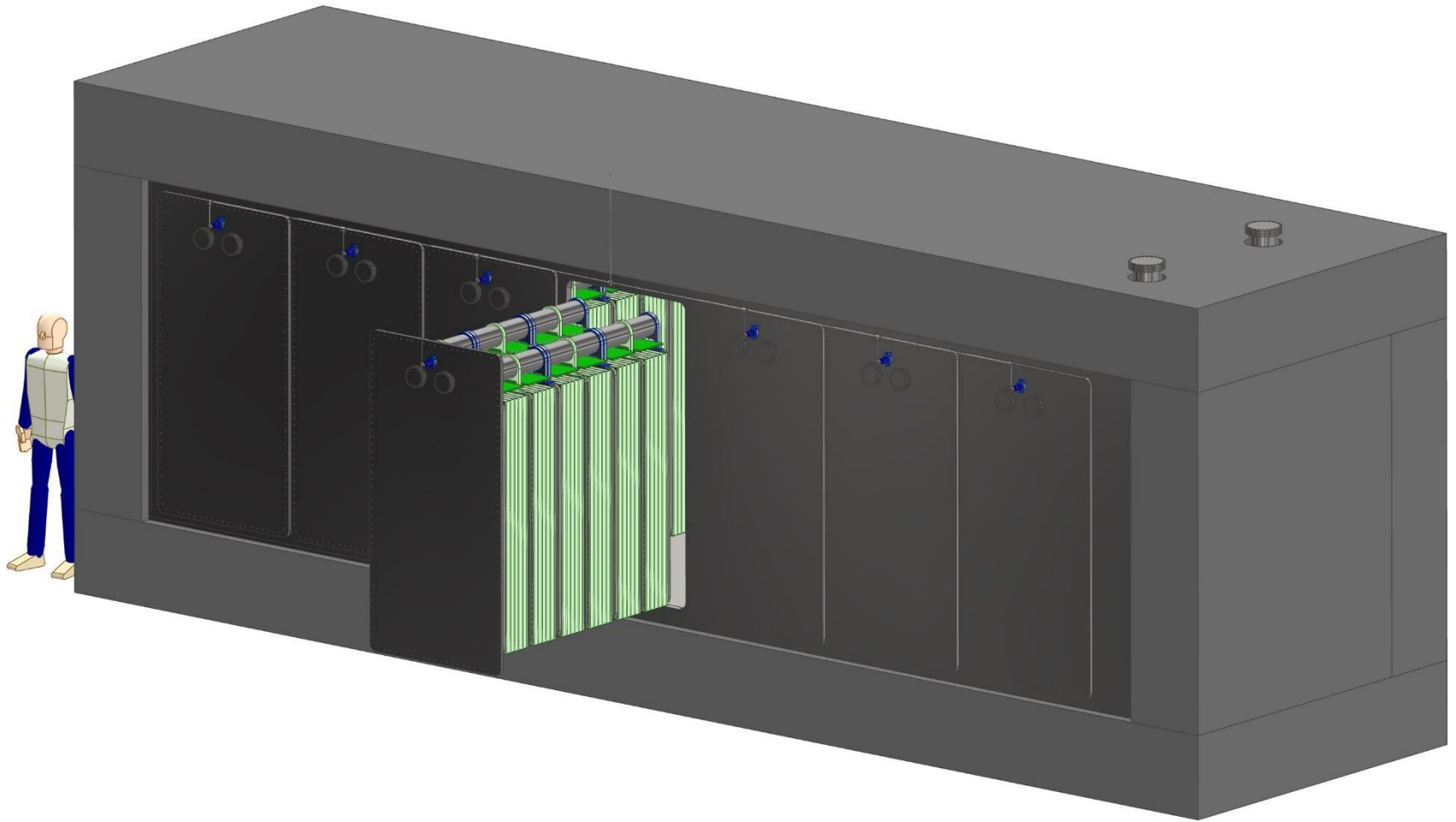

Section view showing the space inside the foam enclosure for services

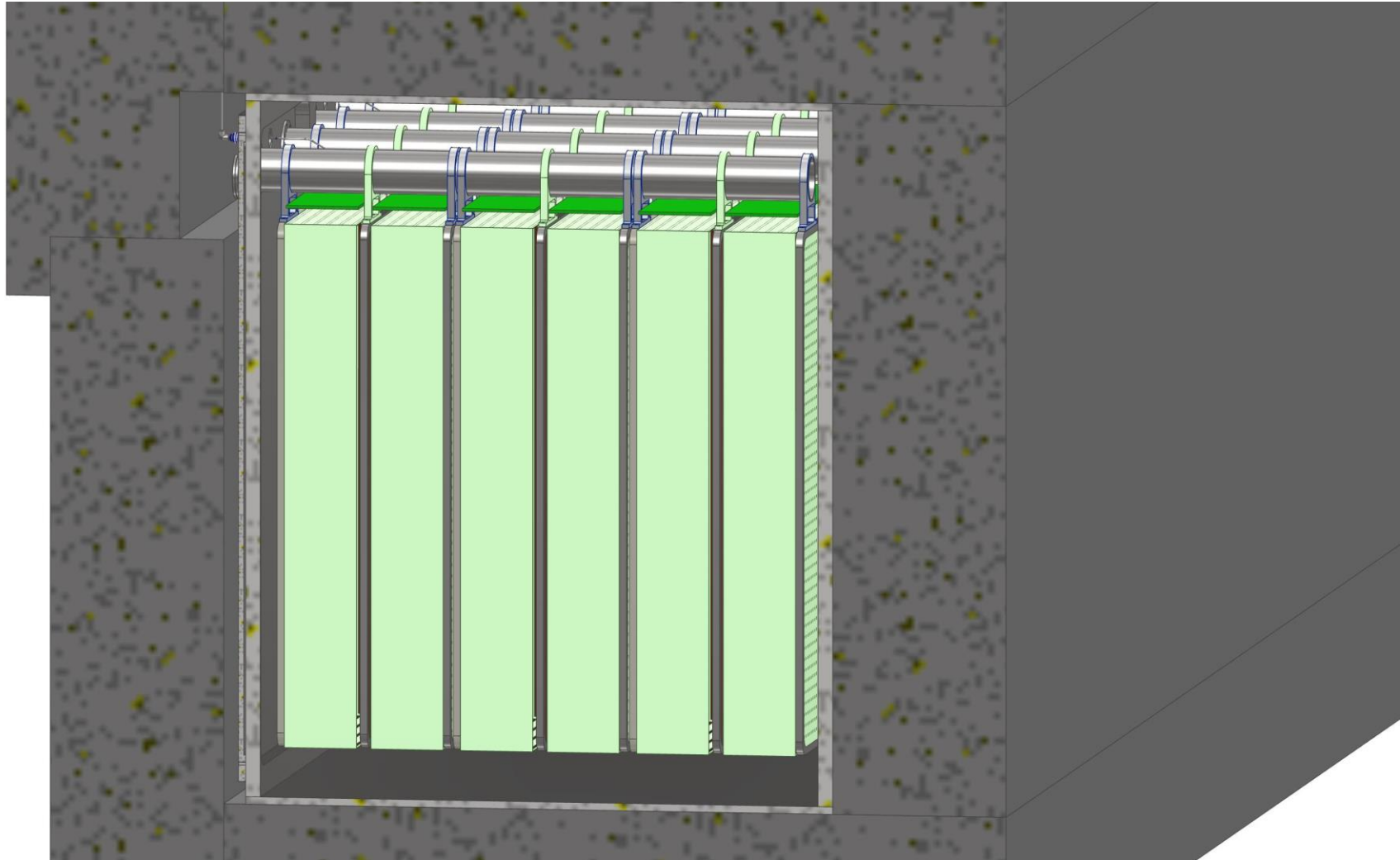

Top foam and plates made transparent

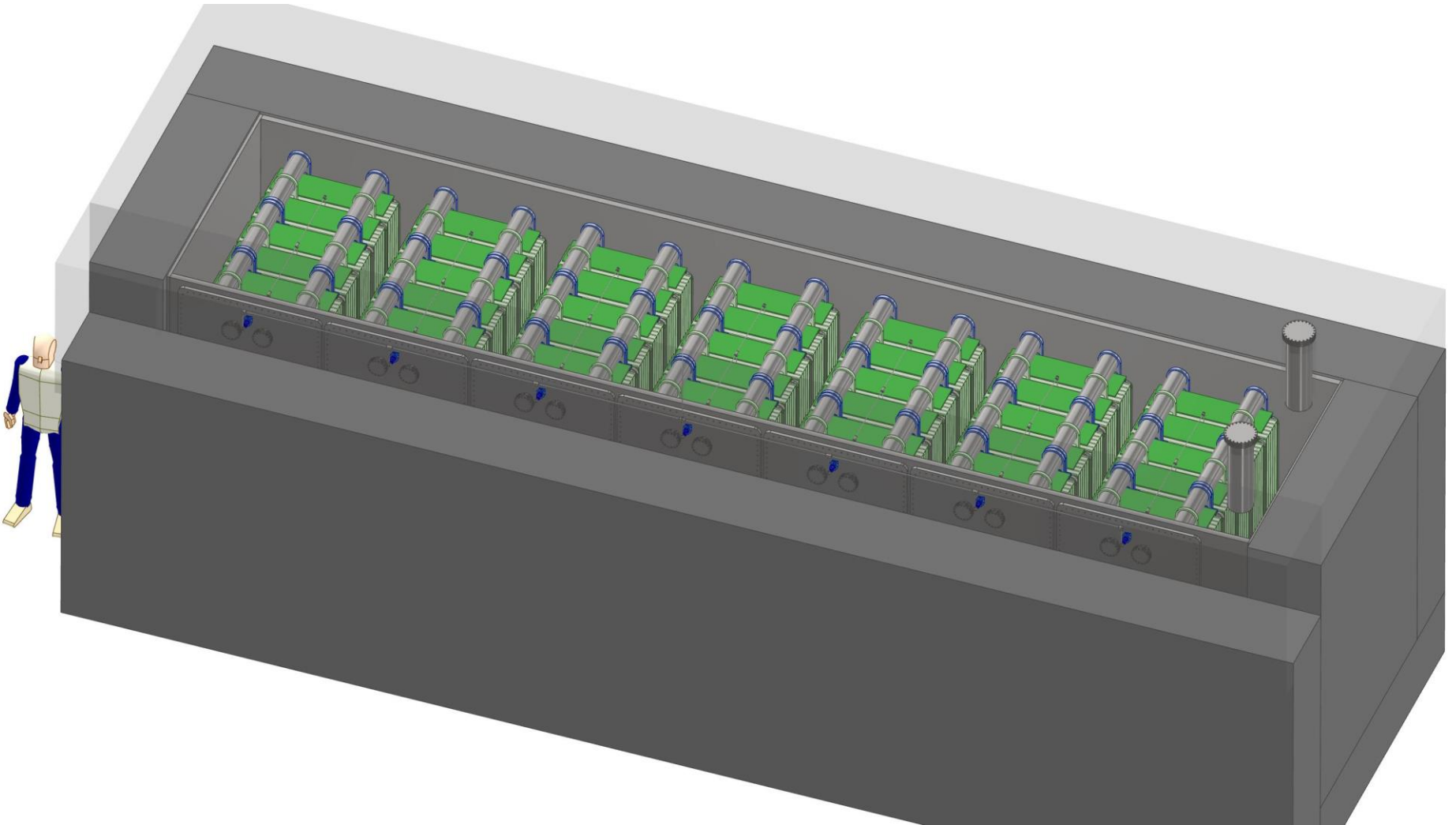

Plan view through the transparent top of the cryostat

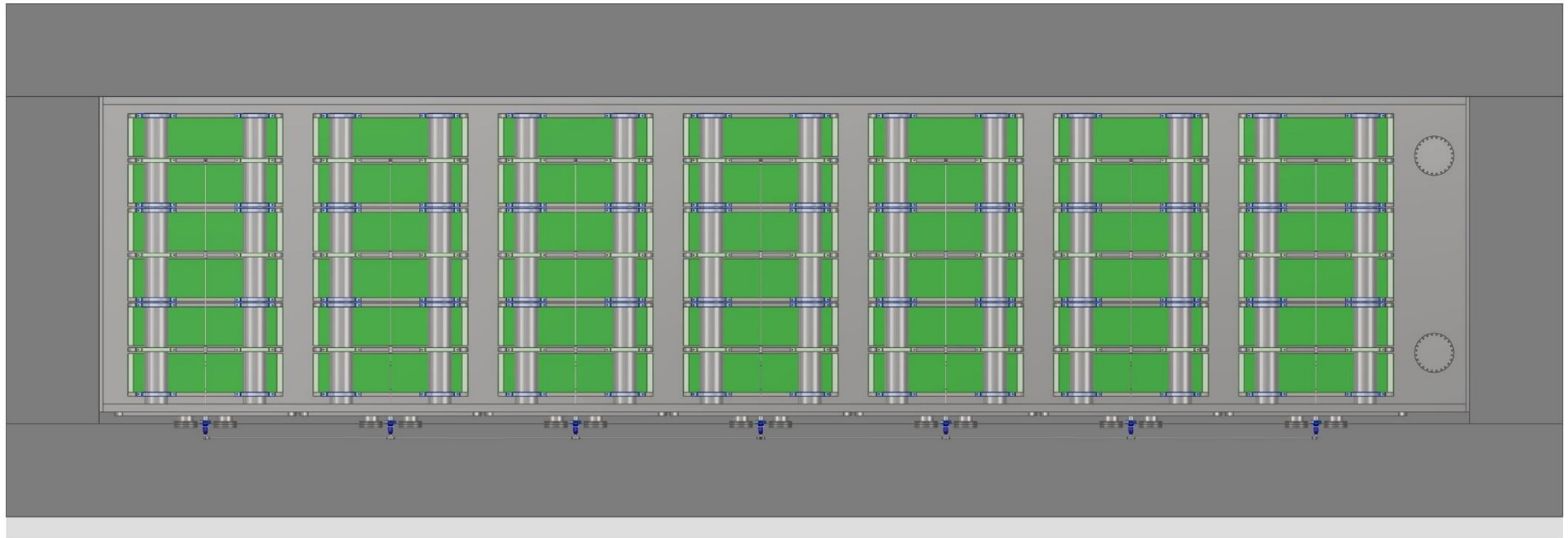

A TPC Module with three TPC cells hanging from cantilevered beams

This is a 20kV feedthrough mounted on an NW40 flange from Lesker, with an aluminum EVAC seal. It is a placeholder since it is not a cryo HV feedthrough.

These are 6 inch conflat flanges with 4" OD tube to get power in and signals out. We'll have to see if this aperture is adequate.

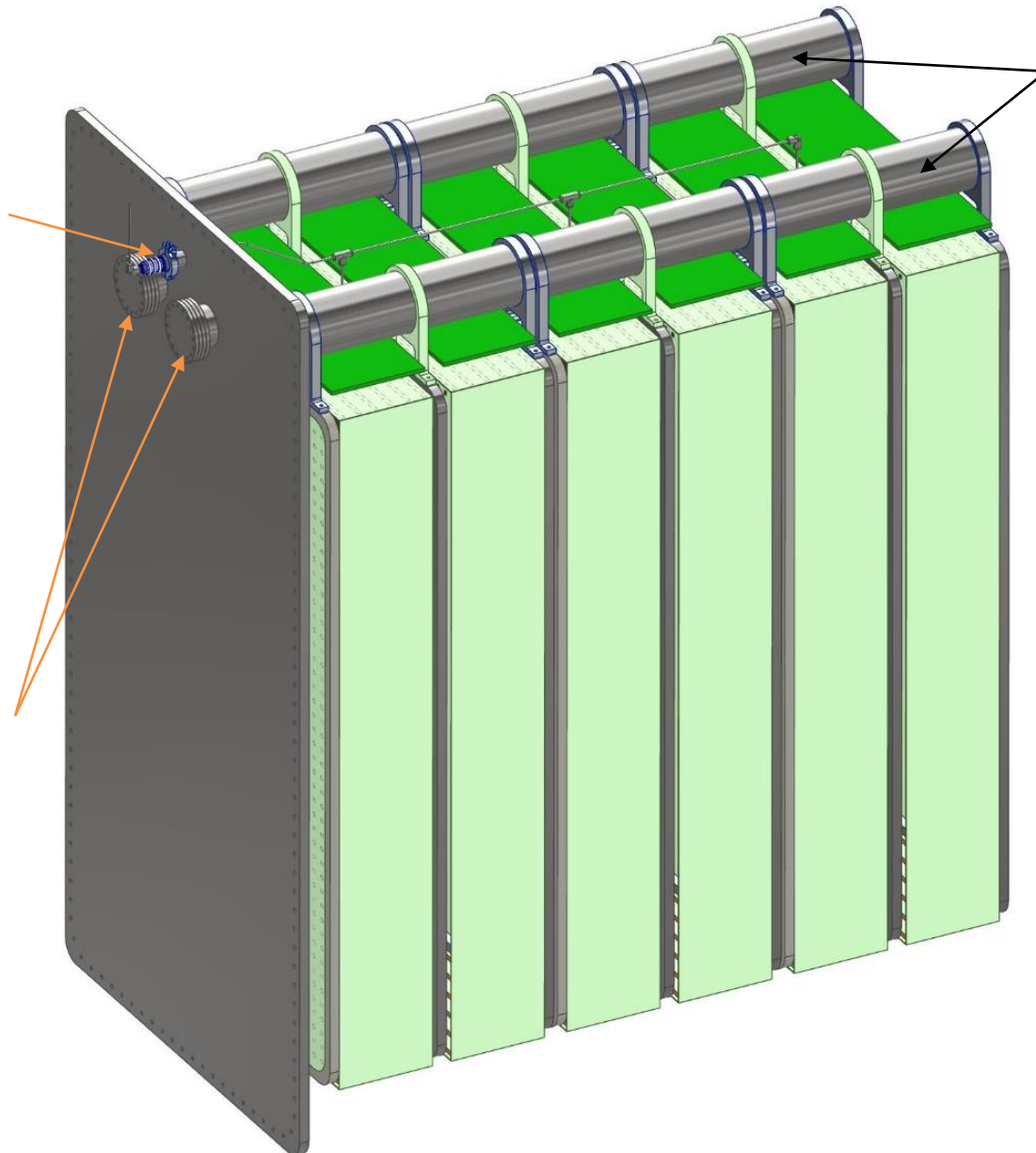

6 inch OD x .250 inch wall stainless tubing is the cantilevered beam that holds the TPCs up. The tubes are welded to flanges bolted to the inside of the cold door.

A TPC Module with 6 foot man next to it for scale

The TPC module weighs
2,400 lbs (1,088.4 kg)
as shown.

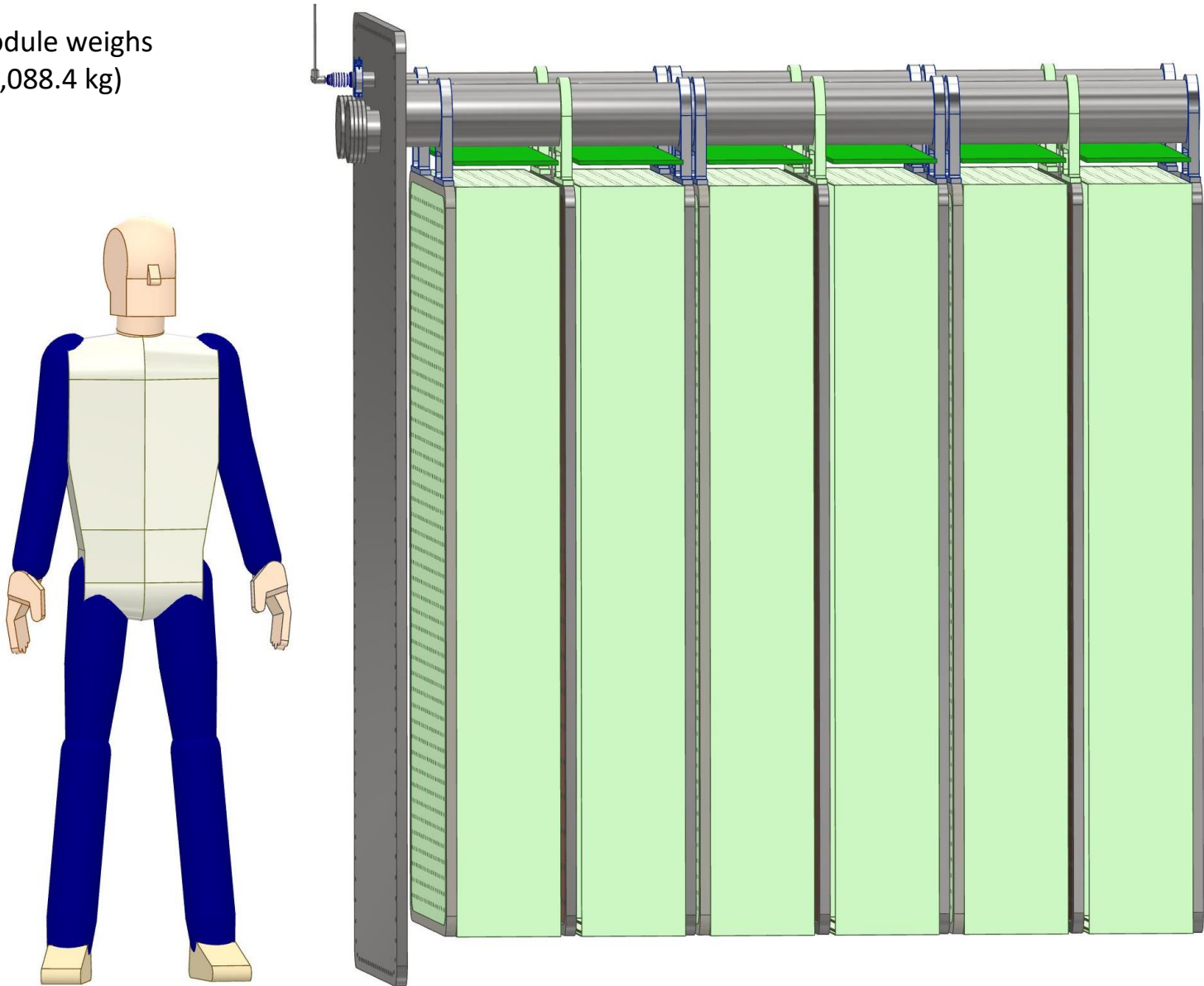

Another view showing a conceptual HV connection scheme to the cathode planes

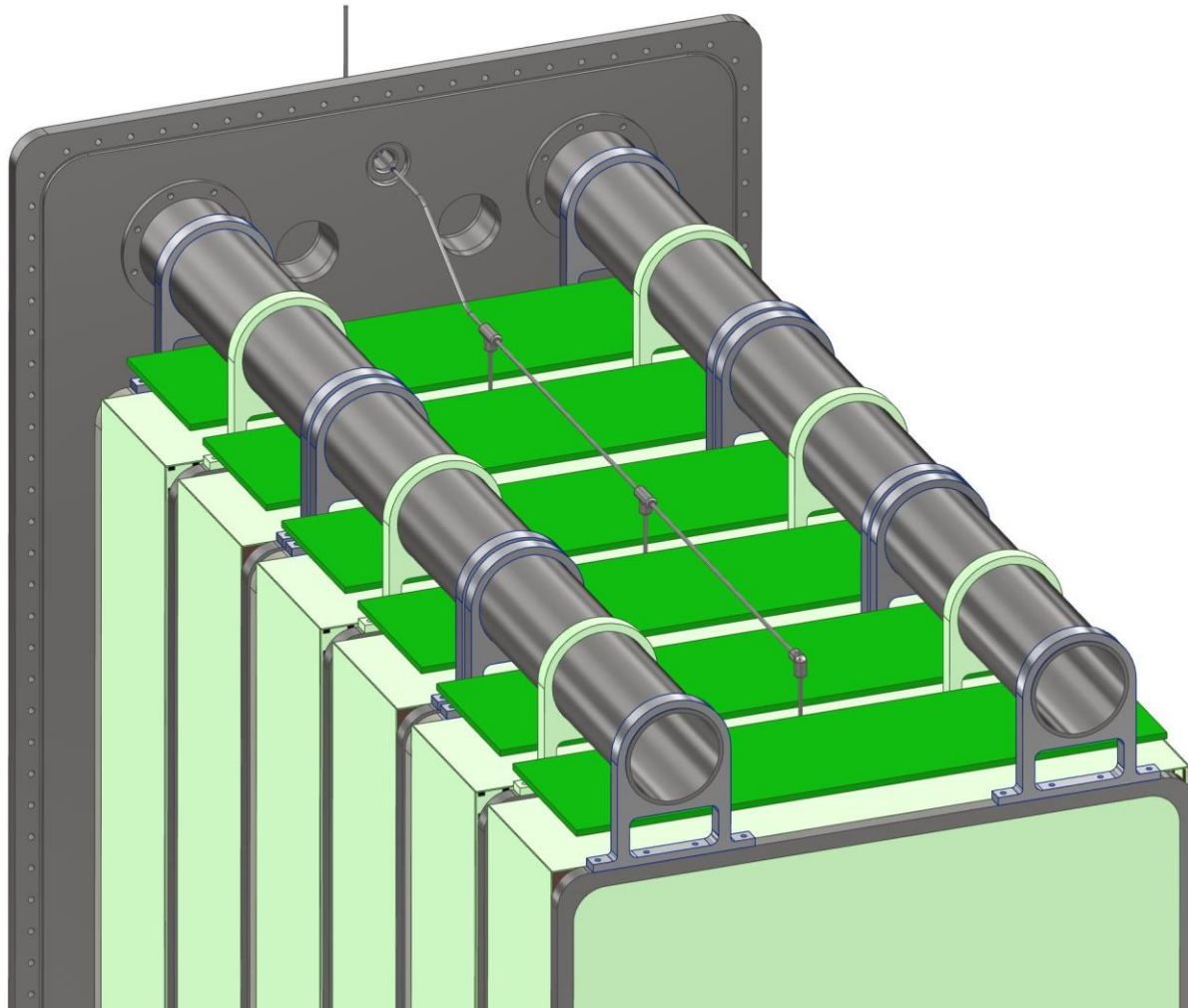

Exploded view of a module showing separate TPCs

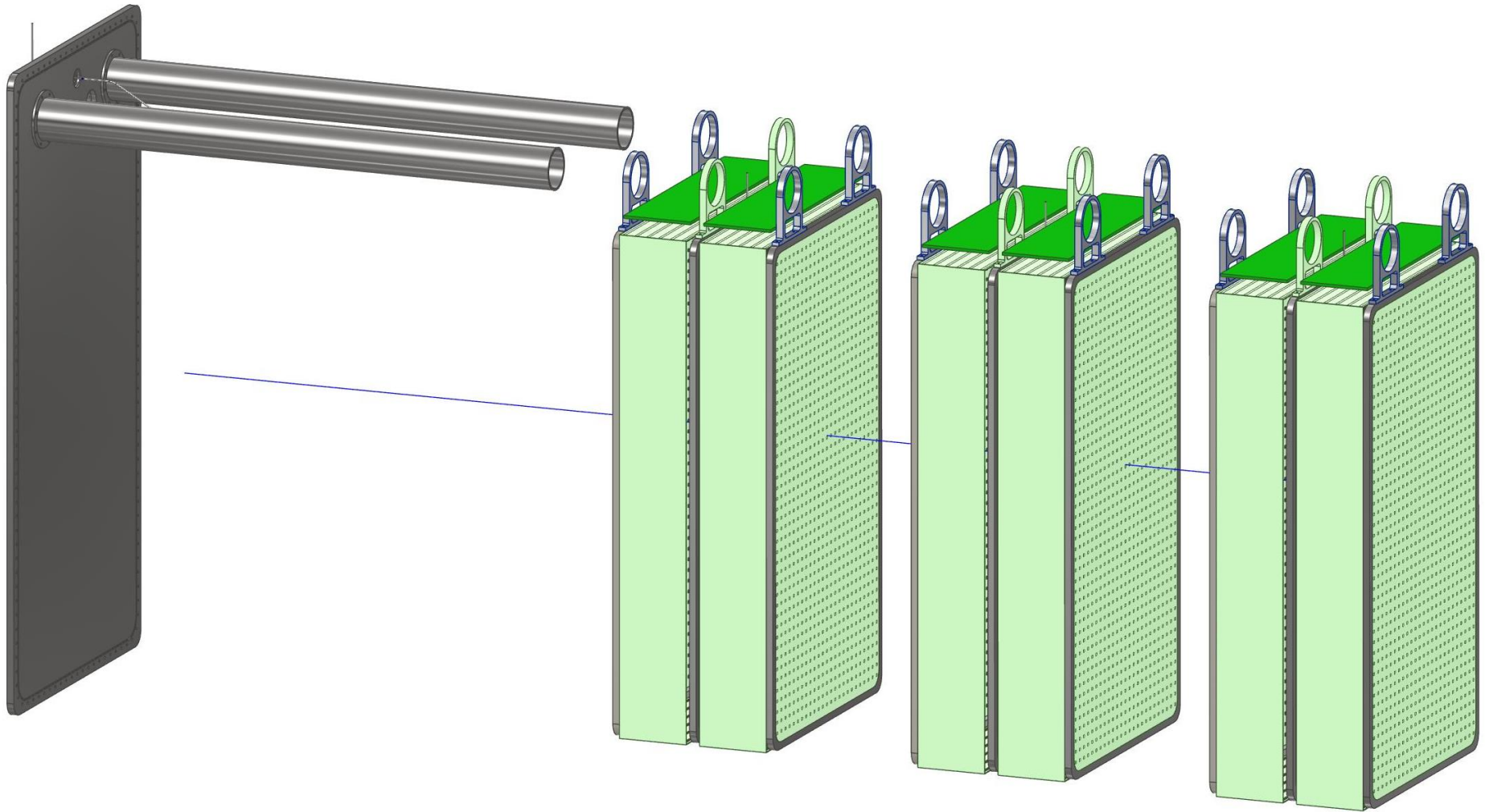

Exploded view of a single TPC cell

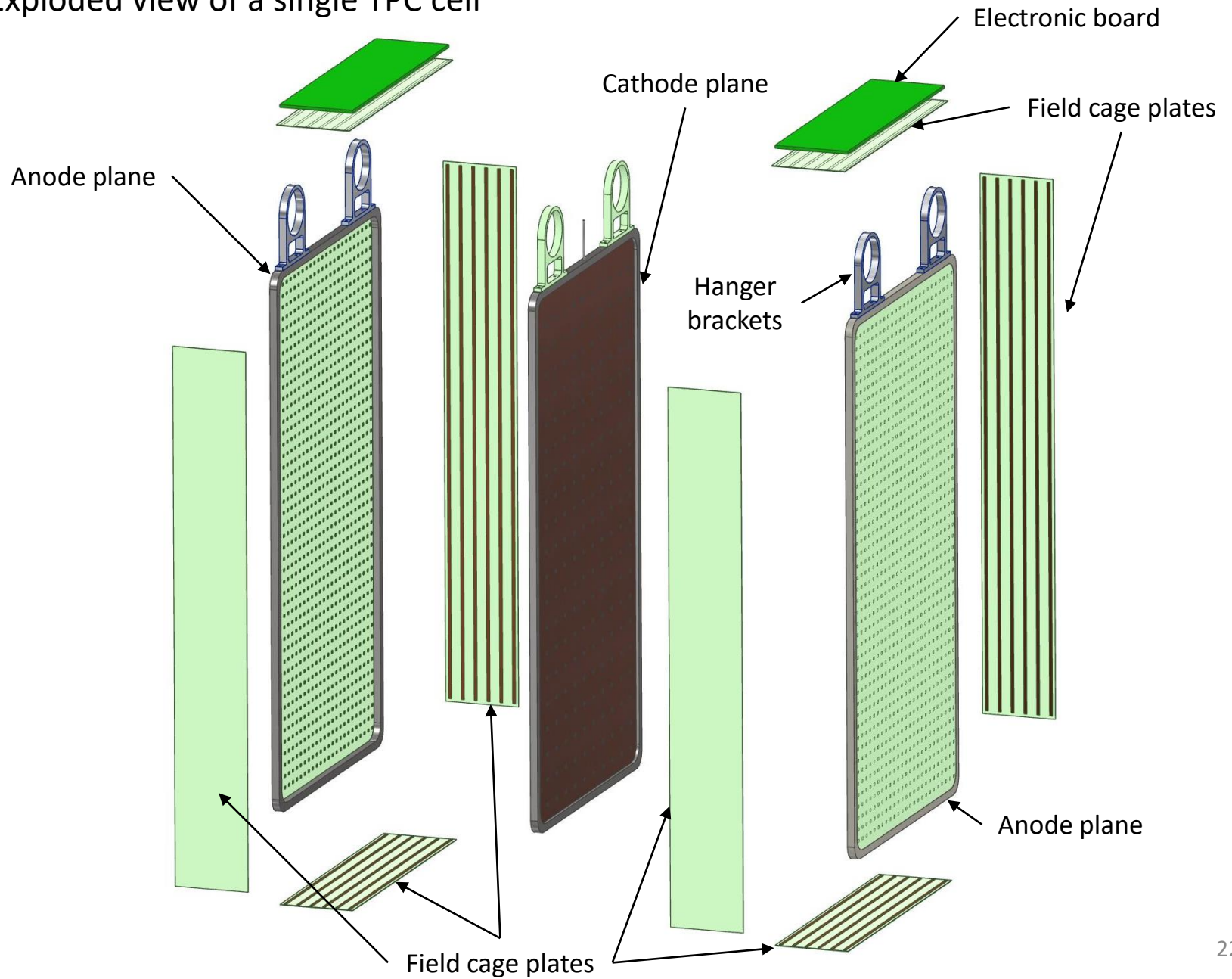

Overall dimensions of the TPC “filing cabinet” cryostat

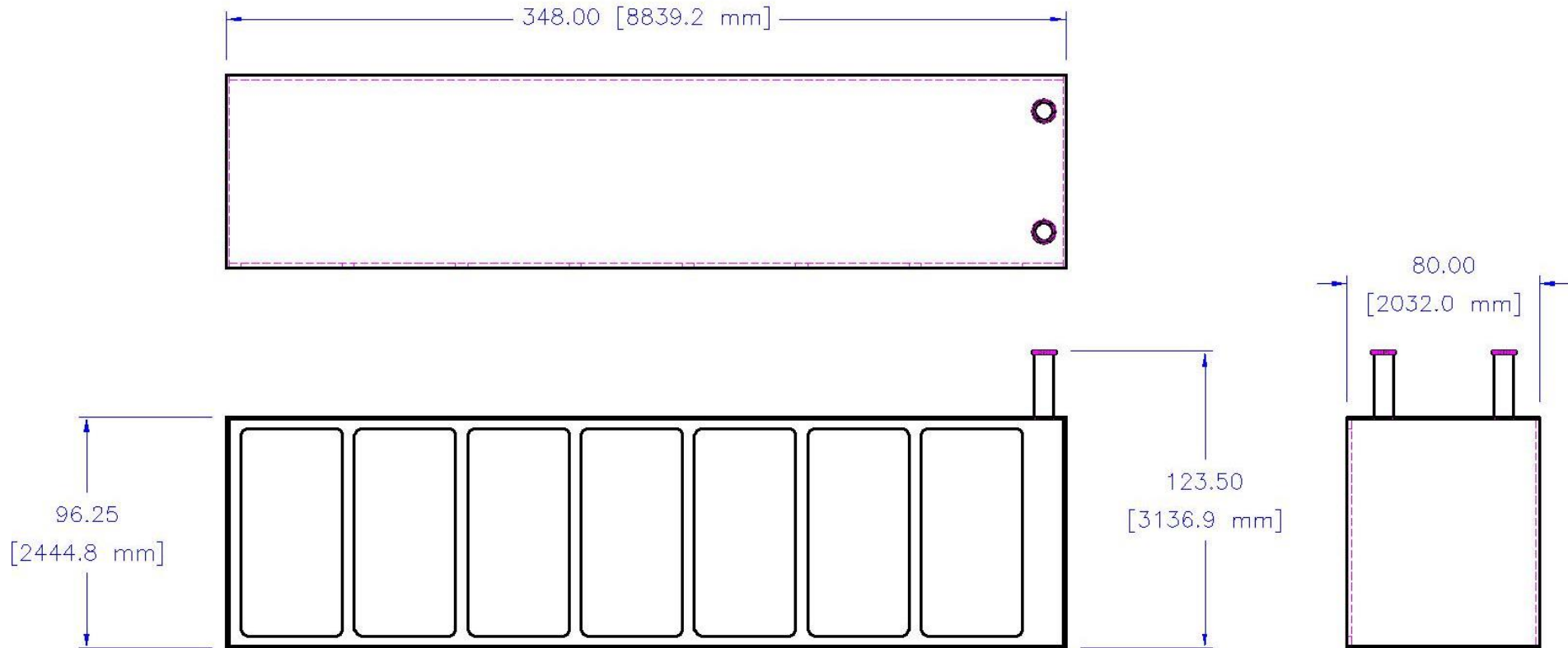

This object weighs 43,546 lbs, 21.8 tons.
(19,749 kg) Can it be brought down the
tunnel shaft in one piece?

Preliminary FEA of vessel and TPC

- I did very basic checks of plate thickness and beam size to verify the feasibility of the design
- Much more sophisticated analyses need to be done yet

Von Mises stress plot, 5 psi internal pressure, 2 inch thick back wall

Type: Von Mises Stress
Unit: ksi
4/19/2024, 4:48:30 PM
13.04 Max

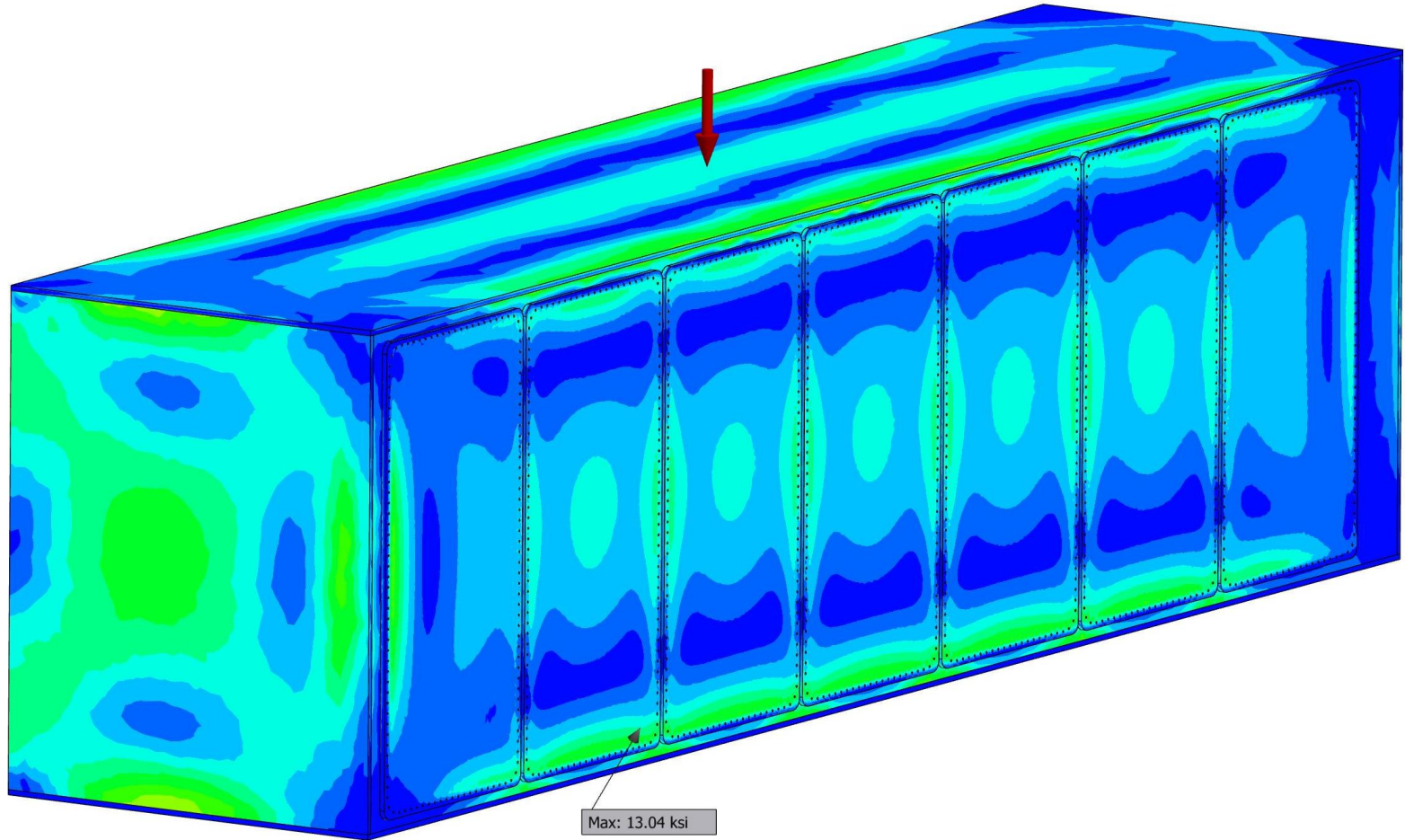
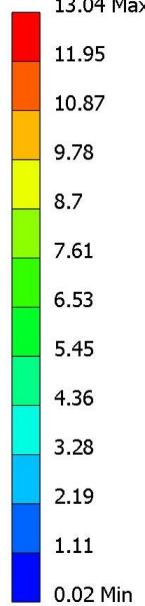

Maximum stress is on the inside radius of the opening in the cryostat wall. Stresses everywhere else are significantly lower.

Von Mises stress plot, 5 psi internal pressure, 2 inch thick back wall

Type: Von Mises Stress
Unit: ksi
4/19/2024, 4:48:30 PM

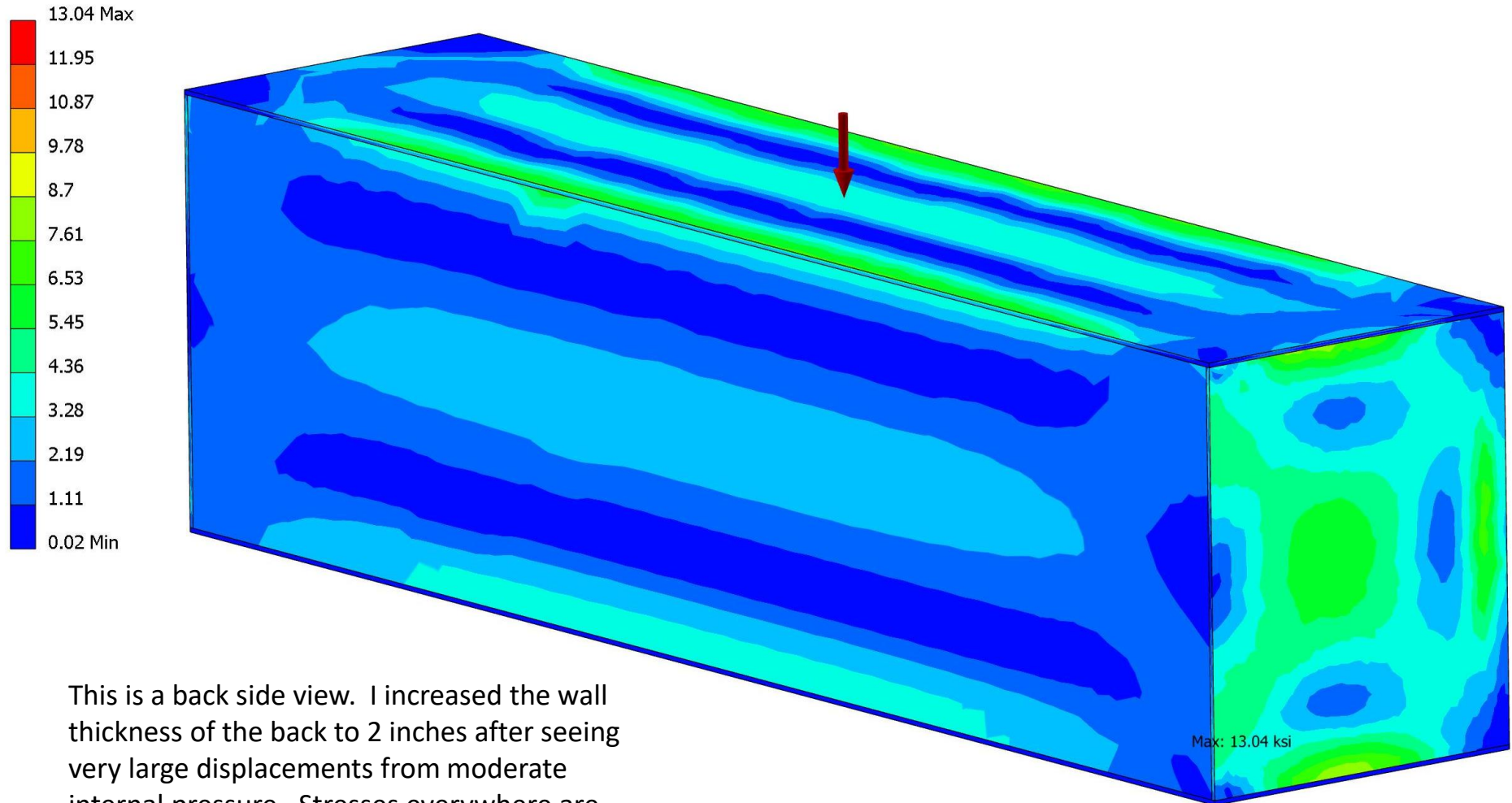

This is a back side view. I increased the wall thickness of the back to 2 inches after seeing very large displacements from moderate internal pressure. Stresses everywhere are now very low and acceptable.

Deflection plot, 5 psi internal pressure, 2 inch thick back wall

Type: Displacement
Unit: in
4/19/2024, 4:49:26 PM

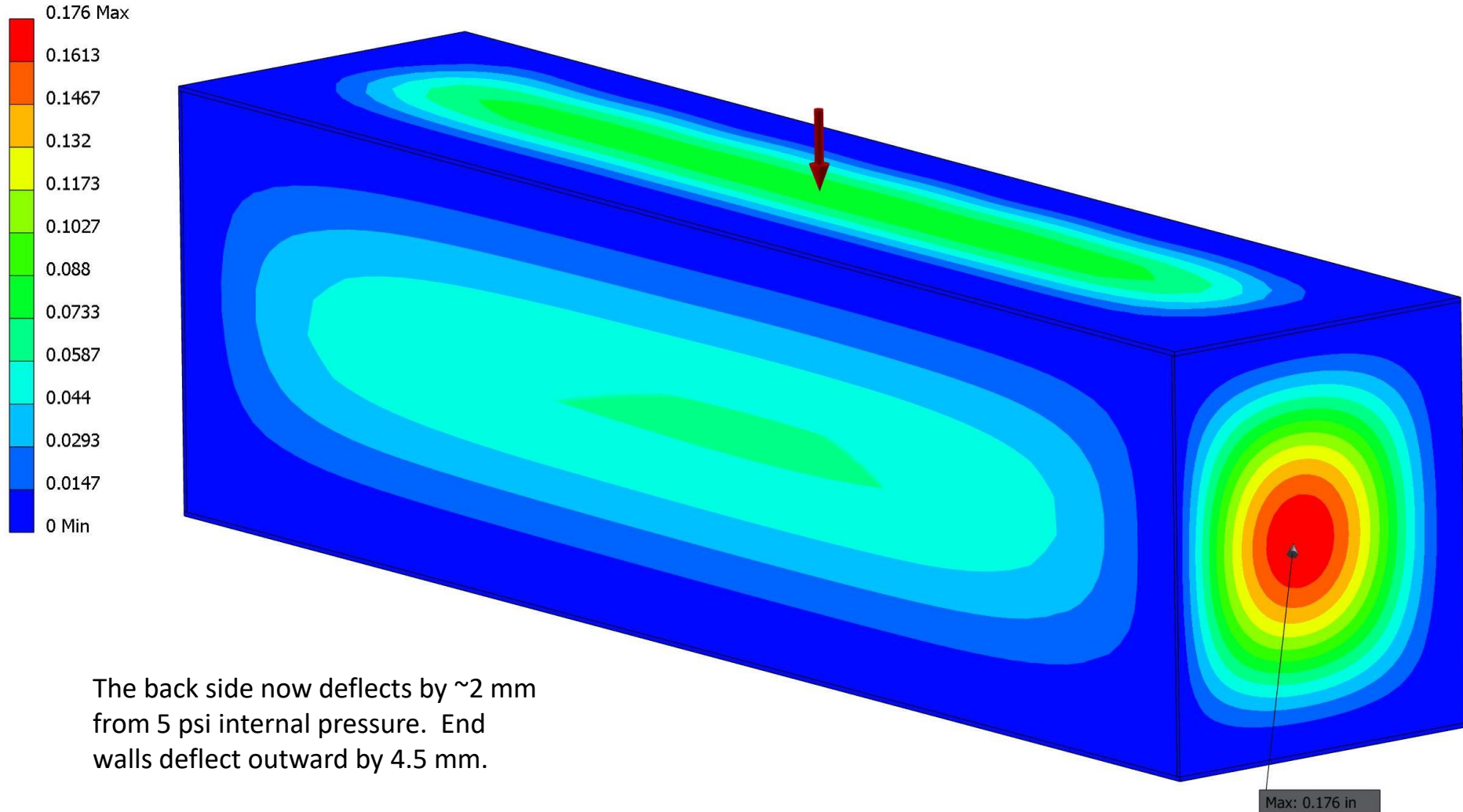

The back side now deflects by ~ 2 mm from 5 psi internal pressure. End walls deflect outward by 4.5 mm.

Deflection plot, 5 psi internal pressure, 2 inch thick back wall

Type: Displacement
Unit: in
4/19/2024, 4:49:26 PM

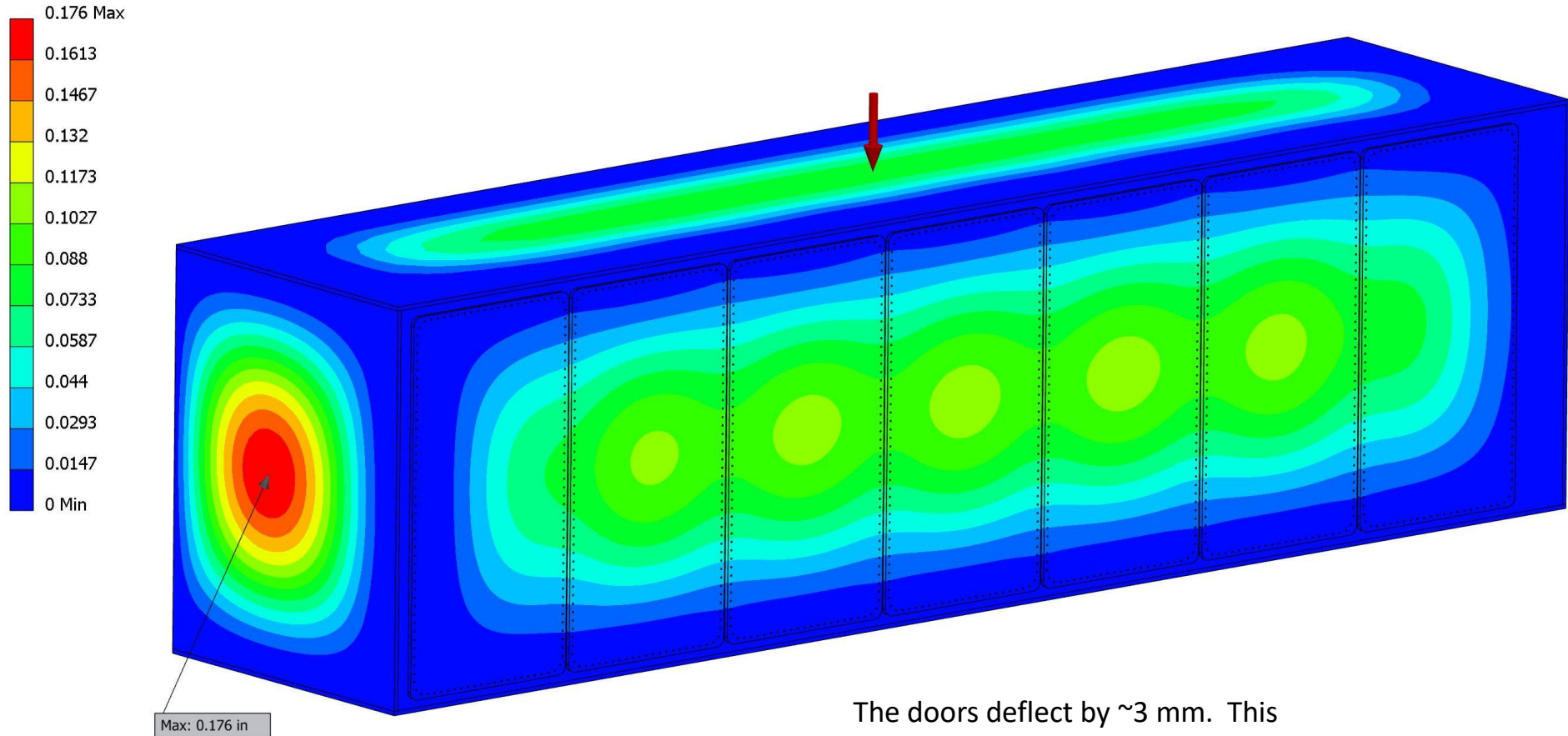

The doors deflect by ~3 mm. This analysis is for uniform internal pressure loading. The hydraulic pressure gradient from the LAr is not included here.

Von Mises stress plot of TPC Module with 1 G load vertical

Type: Von Mises Stress
Unit: ksi
4/23/2024, 12:41:45 AM

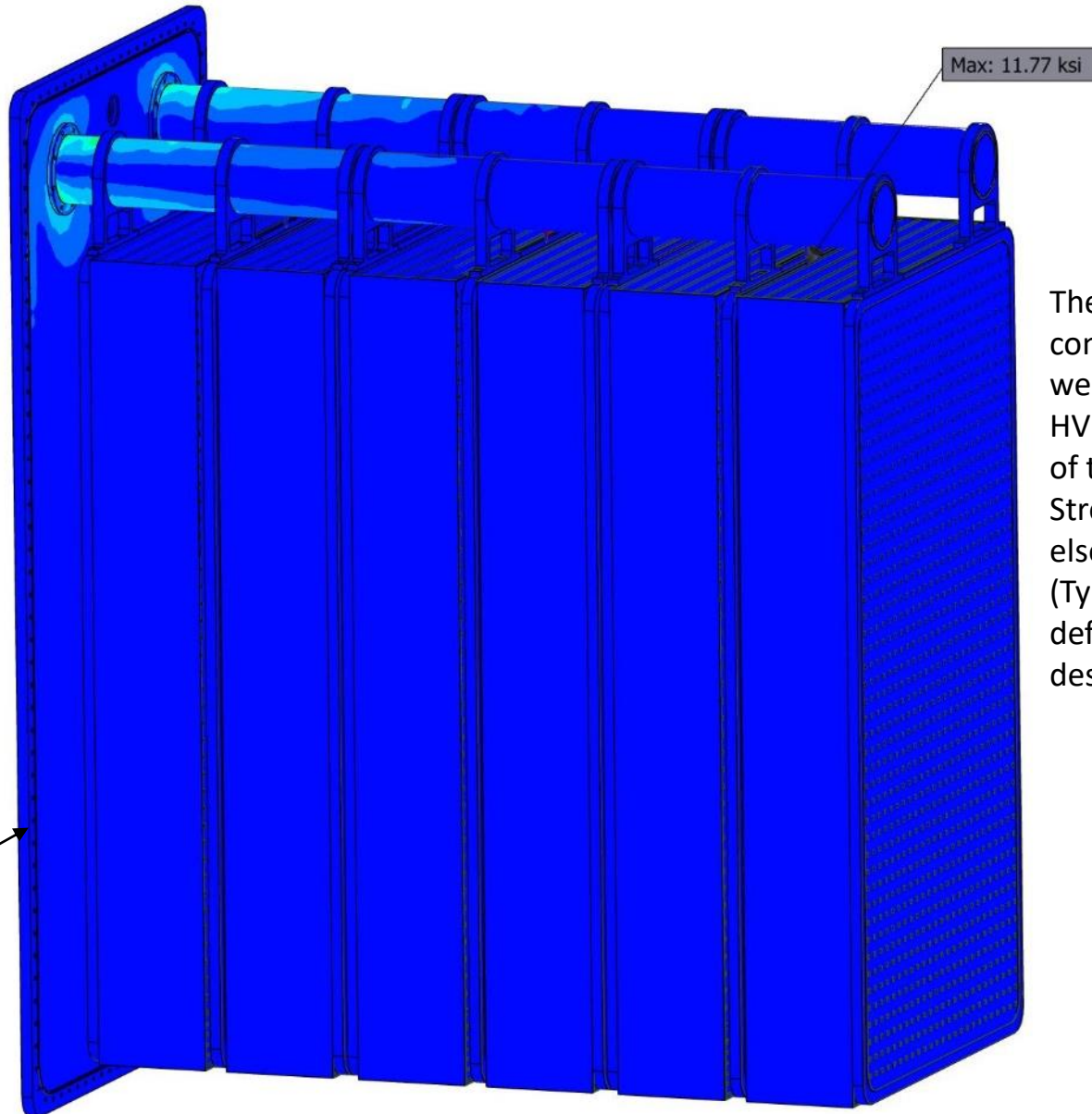
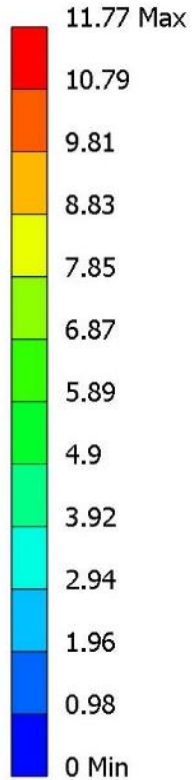

The stress concentration is a weird artifact at the HV connection to one of the cathodes. Stresses everywhere else are very low. (Typical of a deflection driven design.)

I fixed the area where the bolt holes are for the support BC.

Another view of Von Mises stress with 1 G load

Type: Von Mises Stress

Unit: ksi

4/23/2024, 12:41:45 AM

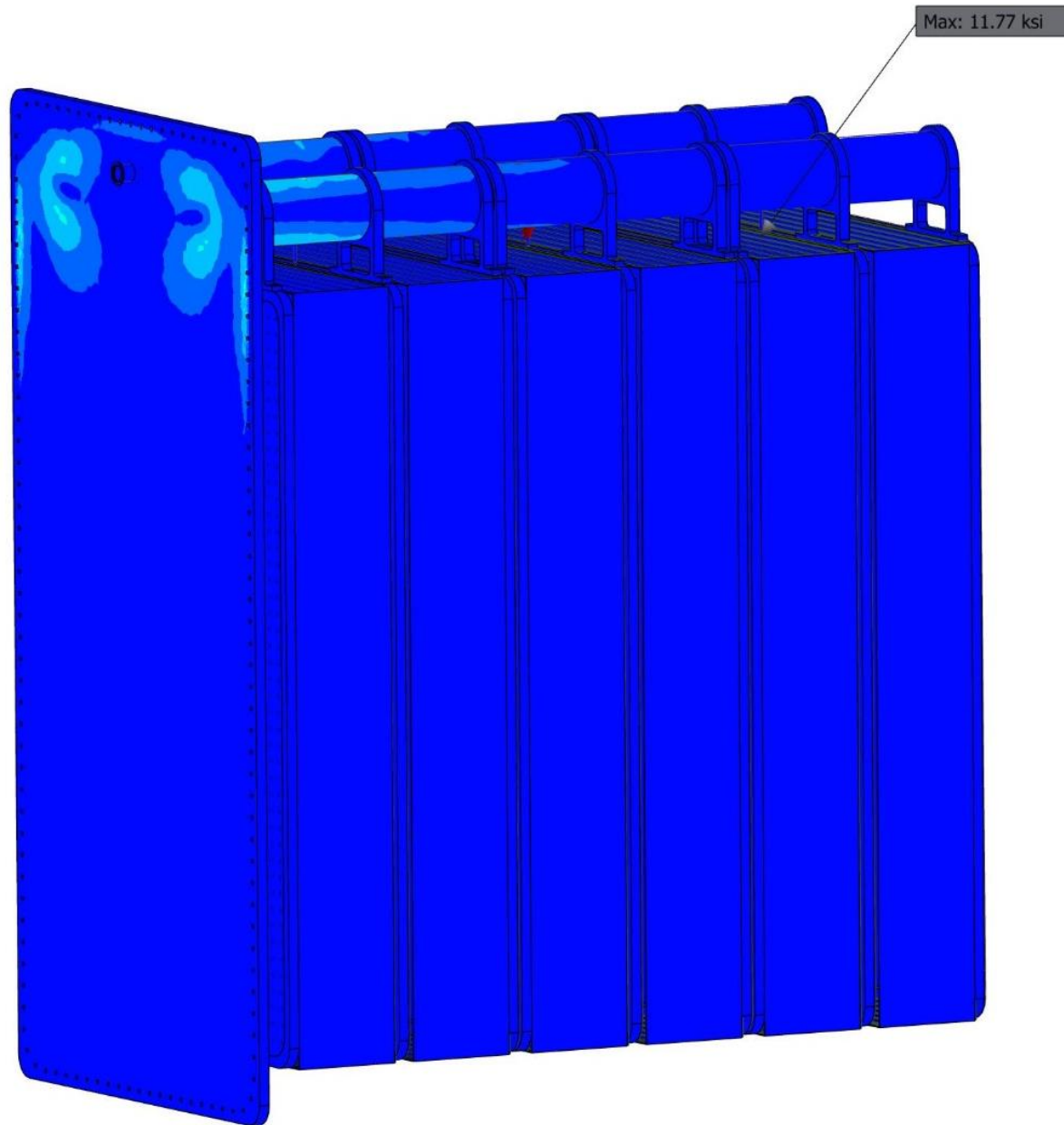
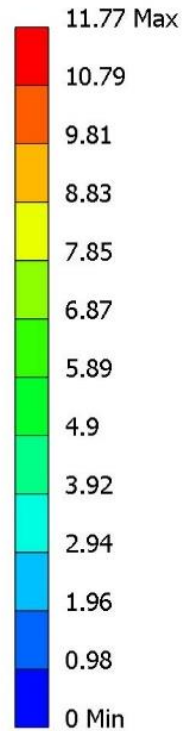

Stresses may be unrealistically low because all of the parts are bonded together in this model. I do not include any sliding freedom.

Total displacement plot of TPC module with 1 G loading

Type: Displacement
Unit: in
4/23/2024, 12:43:21 AM

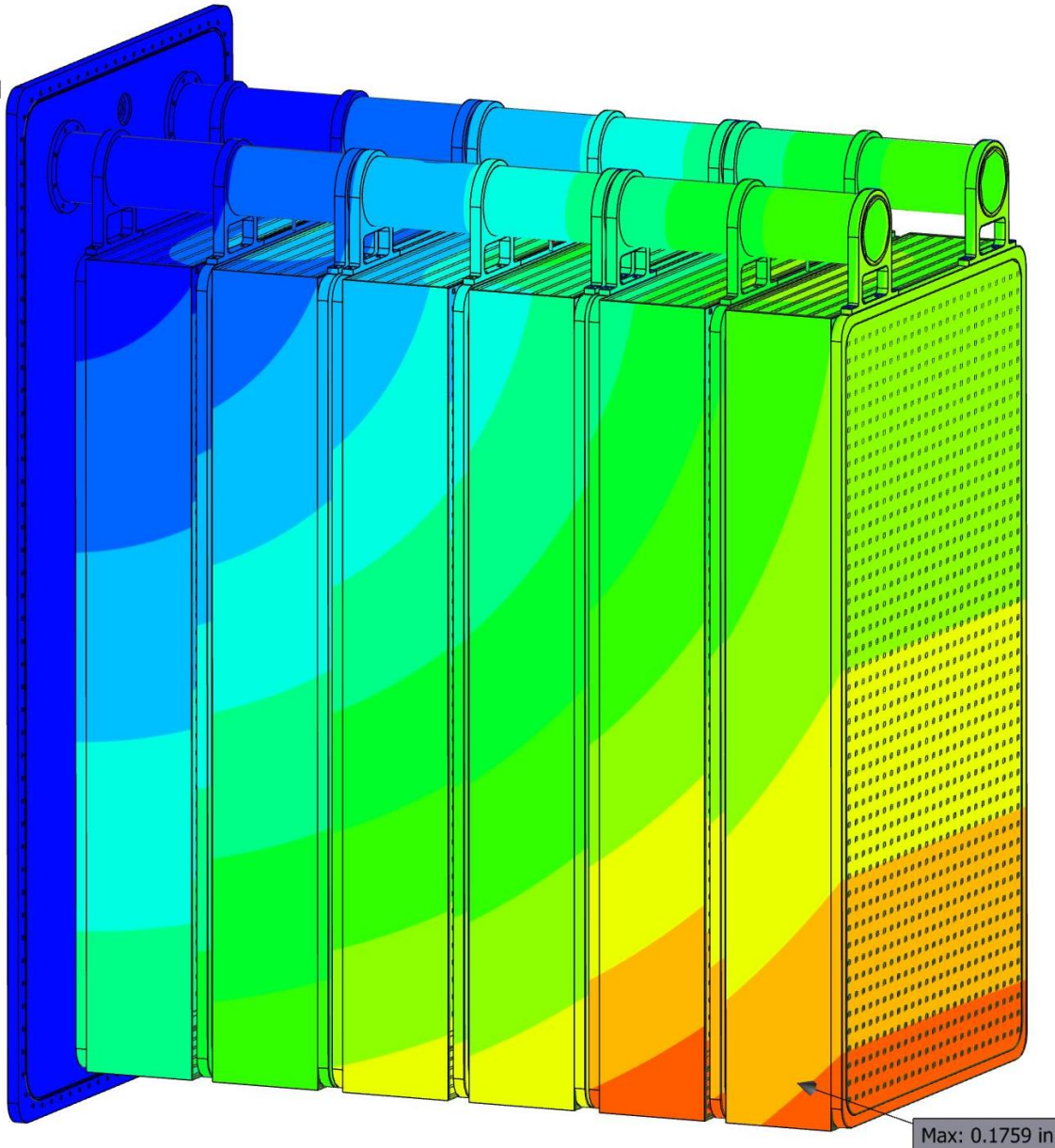
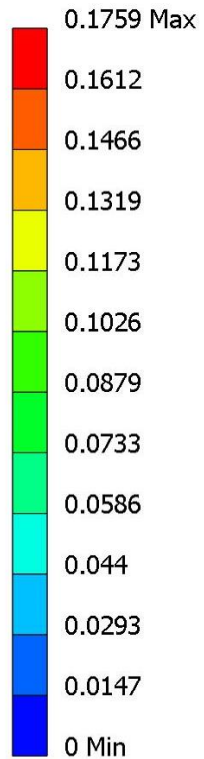

The cantilevered supports appear to be adequate for 1 G loading of the TPC modules.

Z deflection plot of TPC Module with 1 G loading

Type: Z Displacement
Unit: in
4/23/2024, 12:45:16 AM

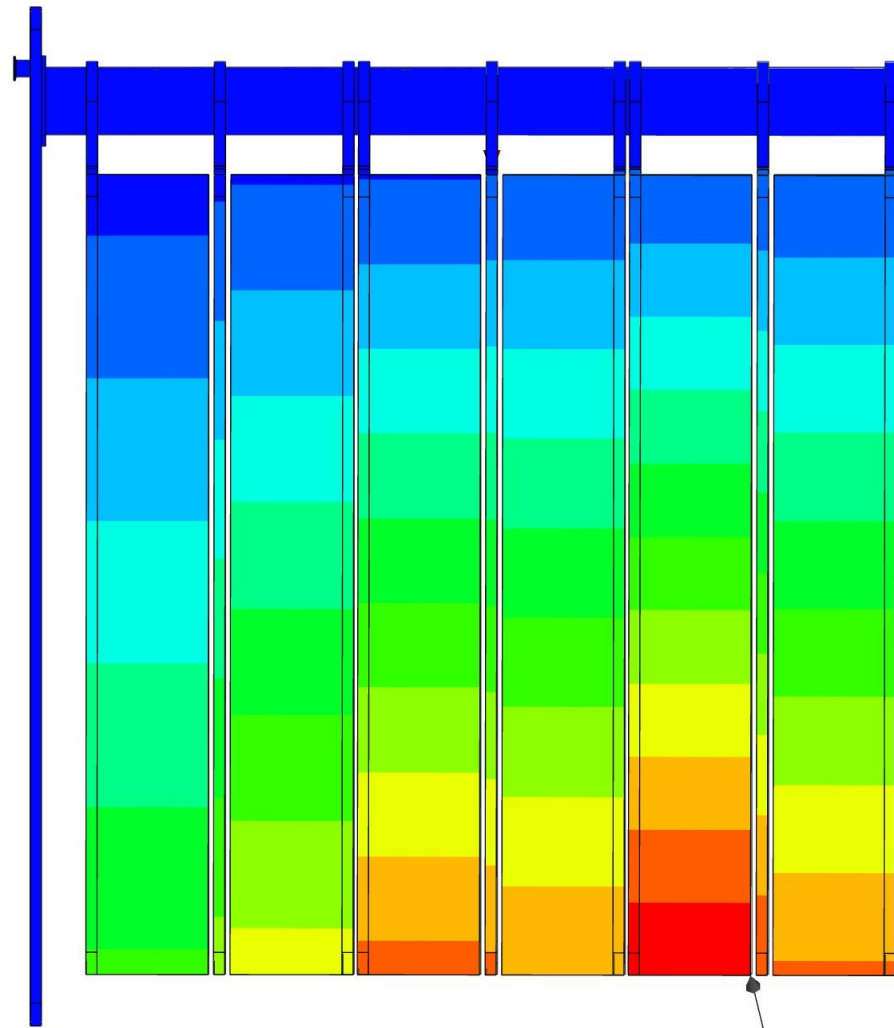
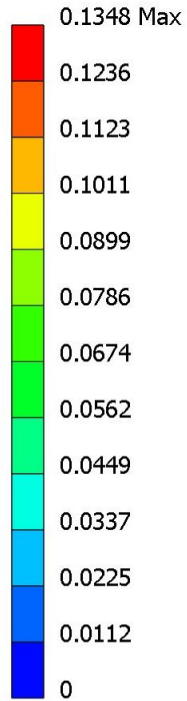

Max: 0.1348 in

The vertical sag causes a horizontal shifting of the bottoms of the TPCs of about 3.5 mm.



Y (vertical) deflection plot of TPC module with 1 G loading

Type: Y Displacement
Unit: in
4/23/2024, 12:44:37 AM

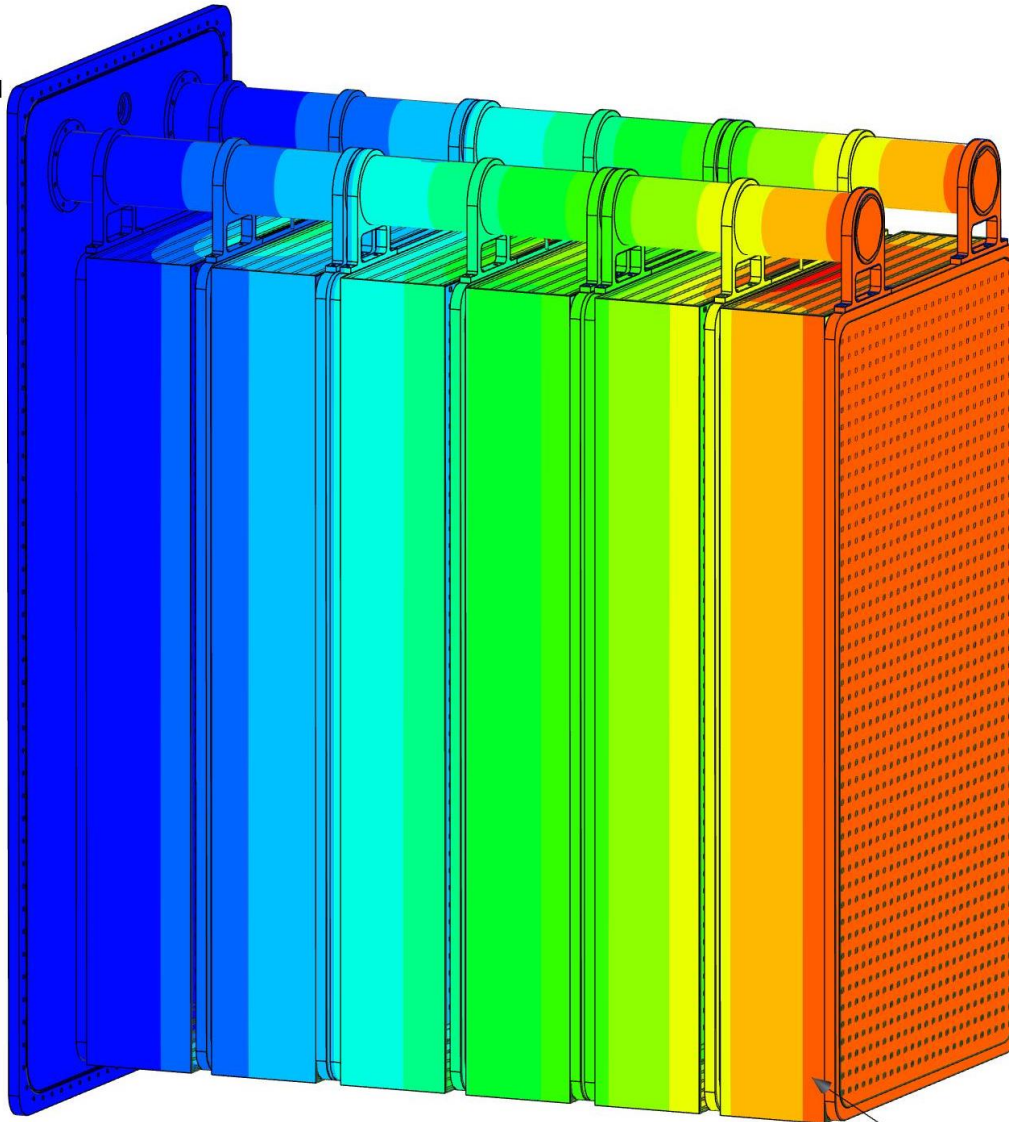
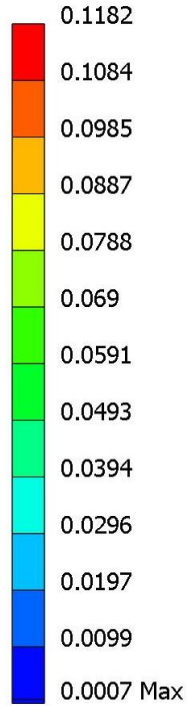

Vertical sag from gravity at the end of the cantilevers is 3 mm.

Max: 0.1182 in

Seal concept for the large rectangular cold doors

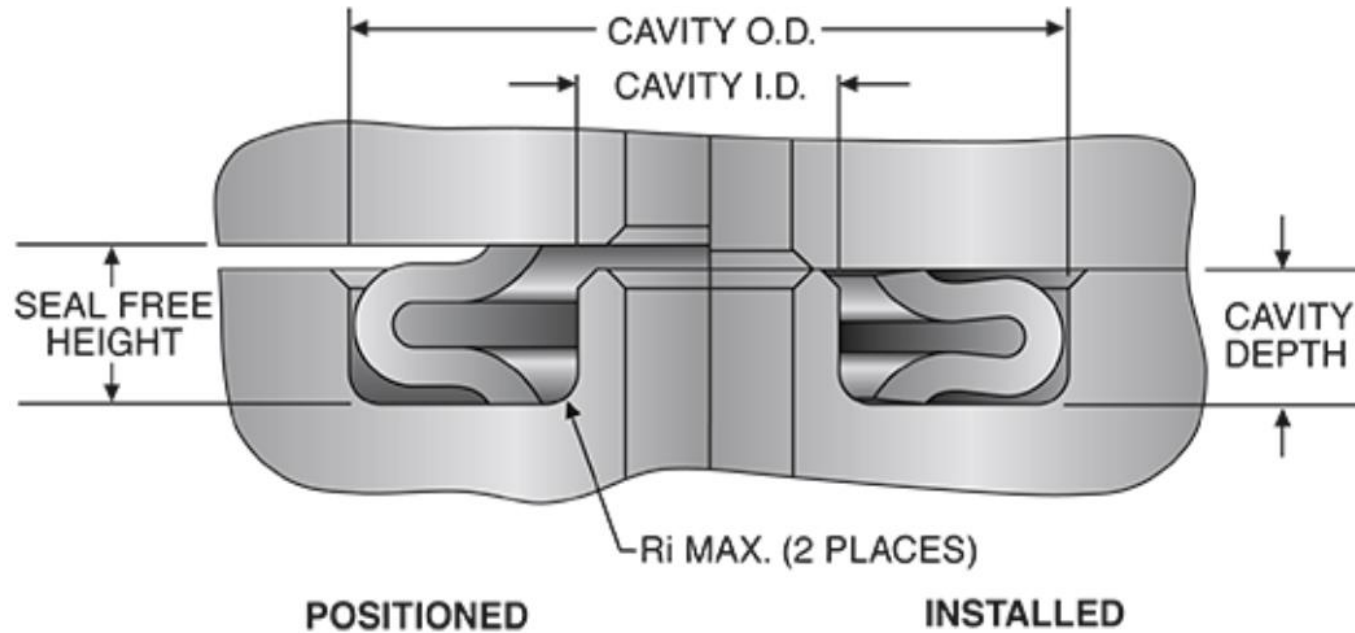

From <https://jetseal.com/> . We used Jetseals in EXO for the cold door on the cryostat.

I am currently working with Jetseal to make sure they can make seals as large as ours.

Summary

- What is presented here is a conceptual design to see if the horizontal support of the TPCs, horizontal insertion and extraction are feasible
- The concept of horizontal assembly was used in EXO
- The single wall, foam insulated cryostat is similar in concept to MicroBooNE
- Much work needs to go into insulation and sealing the insulation from moist air to prevent ice build-up and heat leak