

BNL LAr Test Stands Cryogenic System Review for FLArE Cryogenic Design

Yichen
4/15/2024

LAr Cryogenic System Schematic

- The schematic of FLArE includes Cryogenic, TPC, Front-end electronics and DAQ to carry out physics
- We have a 20-L and a 260-L LAr cryogenic system with gas purification at BNL
- FLArE Cryostate has $\sim 24000\text{L}$ LAr volume
- The gas purification scheme of LAr test stands at BNL can be used for FLArE

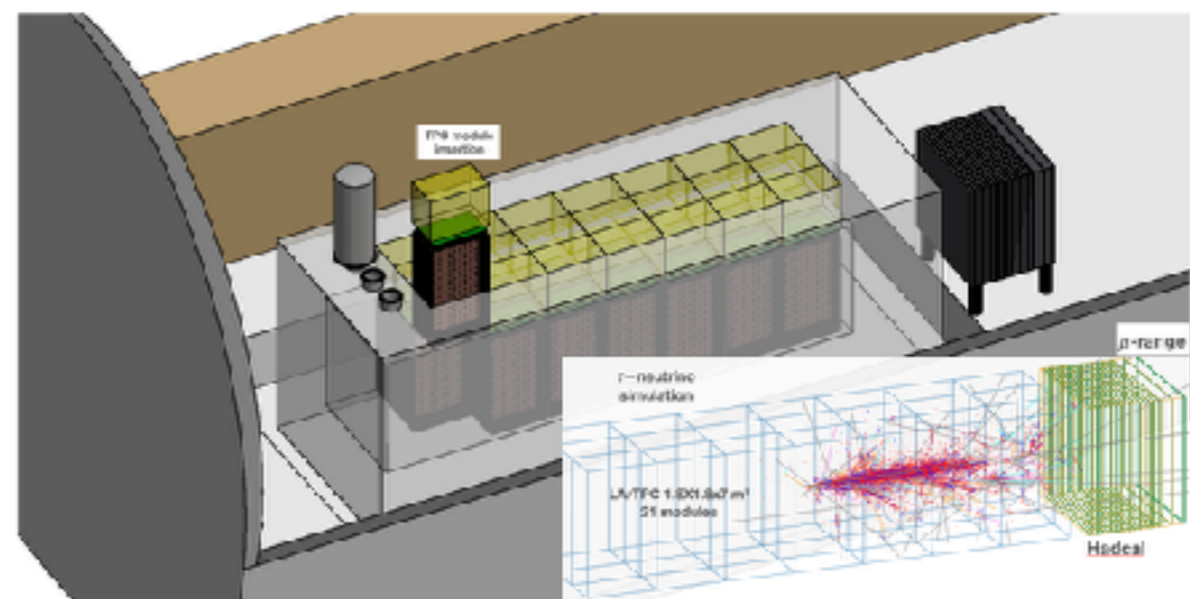
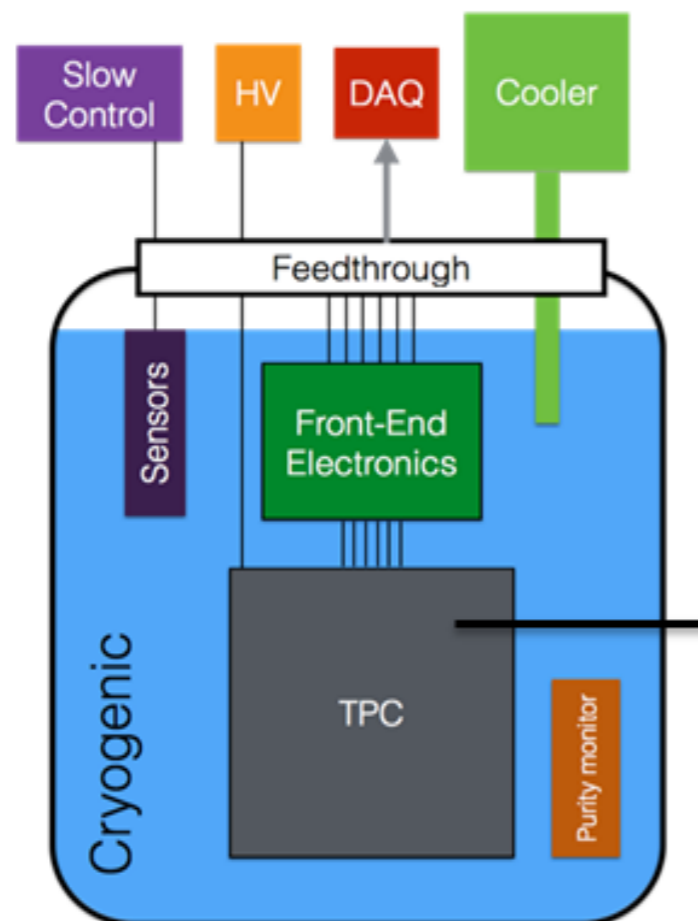

LAr Cryogenic System in General

The cryogenic system is to establish the experimental conditions with high purity LAr

3 essential components:

1. **Cryogenic dewar + Top flange:** holding LAr and TPC, interfacing with other sub-systems
2. **Cooling system (condenser):** condensing GAr to LAr and maintaining the Ar circulation
3. **Purification system (purifier):** Remove impurities
 - purifier in circulation
 - purifier on the fill line
 - purity monitor for direct electron life time measurement
 - purity analyzers (commercial analyzers with tube dipping into the LAr)

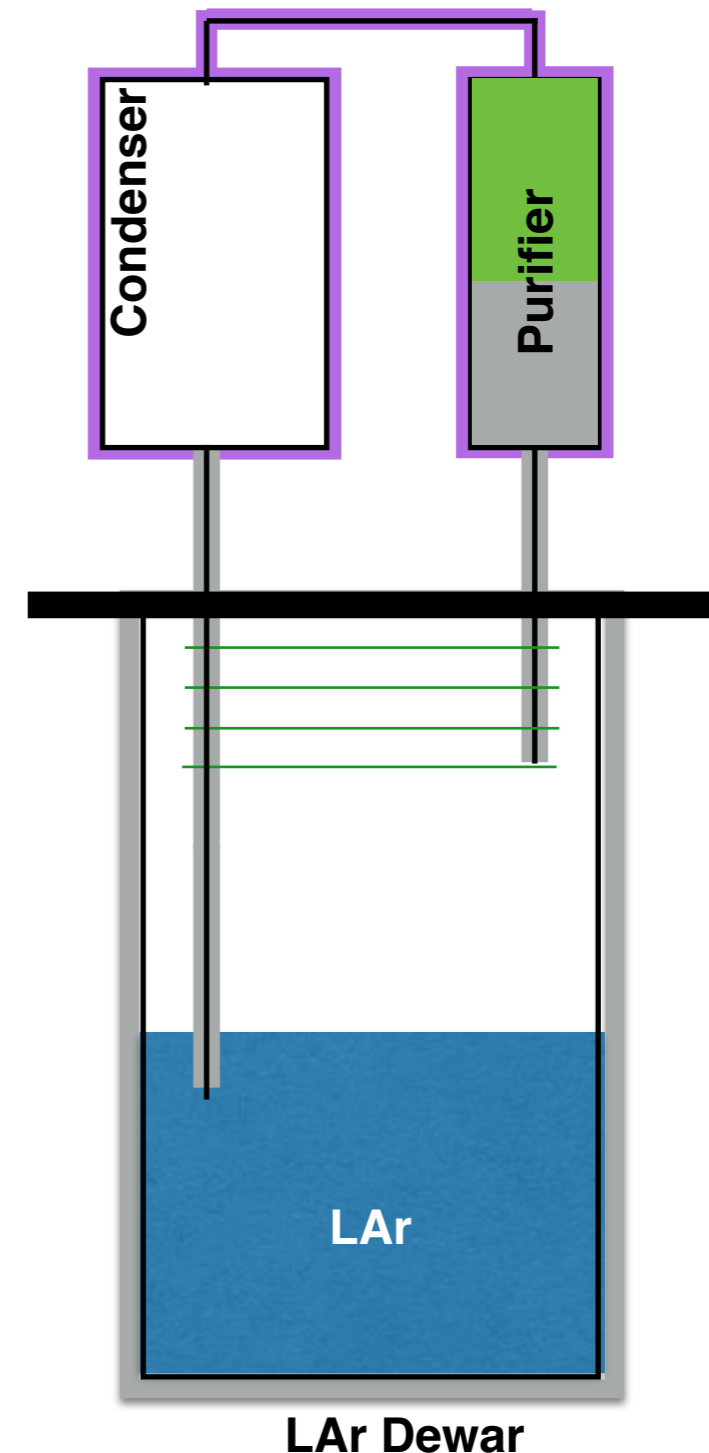

LAr Cryogenic Operation Principle

- System is continuously purified with the gas circulation
 - Circulation is maintained by the evaporation of LAr with intrinsic heat into the dewar
 - Purification is achieved as the gas flows through scrubber materials
 - Purified GAr is cooled and condensed back into LAr by the condenser
- Circulation rate is determined by the heat into the LAr
- Sources of contaminations:
 - >Initial LAr supply
 - >Leaks (interfaces at warm)
 - >Outgassing (mainly at warm temperature)
- Gas purification remove the contaminations at the sources

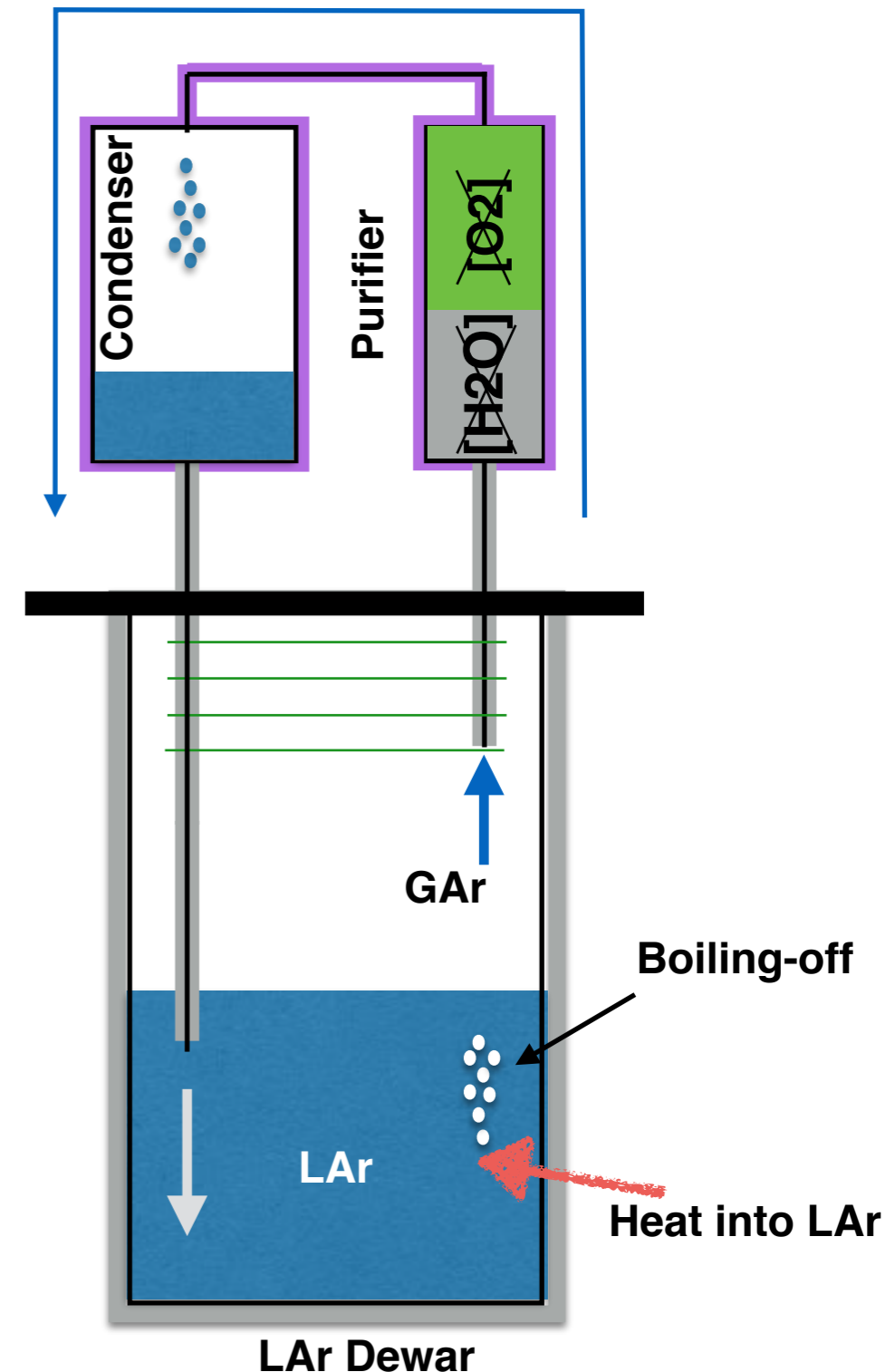

Proof of Principle with the 20-L LAr Test Stand

- Purification of the 20-L system
 - The purifier is filled with 13x molecular sieve and GetterMax 133 oxygen getter
 - Gas purification by heat into the system, ultra-high purity level has been achieved < 1.0 ppb (Y. Li *et al.*, *JINST 11*, T06001) in about a week
- Power consumption of 20-L system
 - The cooling is achieved by pressured LN2 filled in the condenser, The total heat load of the 20-L system is measured to be 46 ± 5 W with the heater off, i.e. full LAr volume exchange in ~ 20 hrs
 - The circulation can be accelerated by a heater immersed in the LAr with a maximum heating power of 150 W
 - Condenser is capable of providing sufficient cooling with maximum heat load

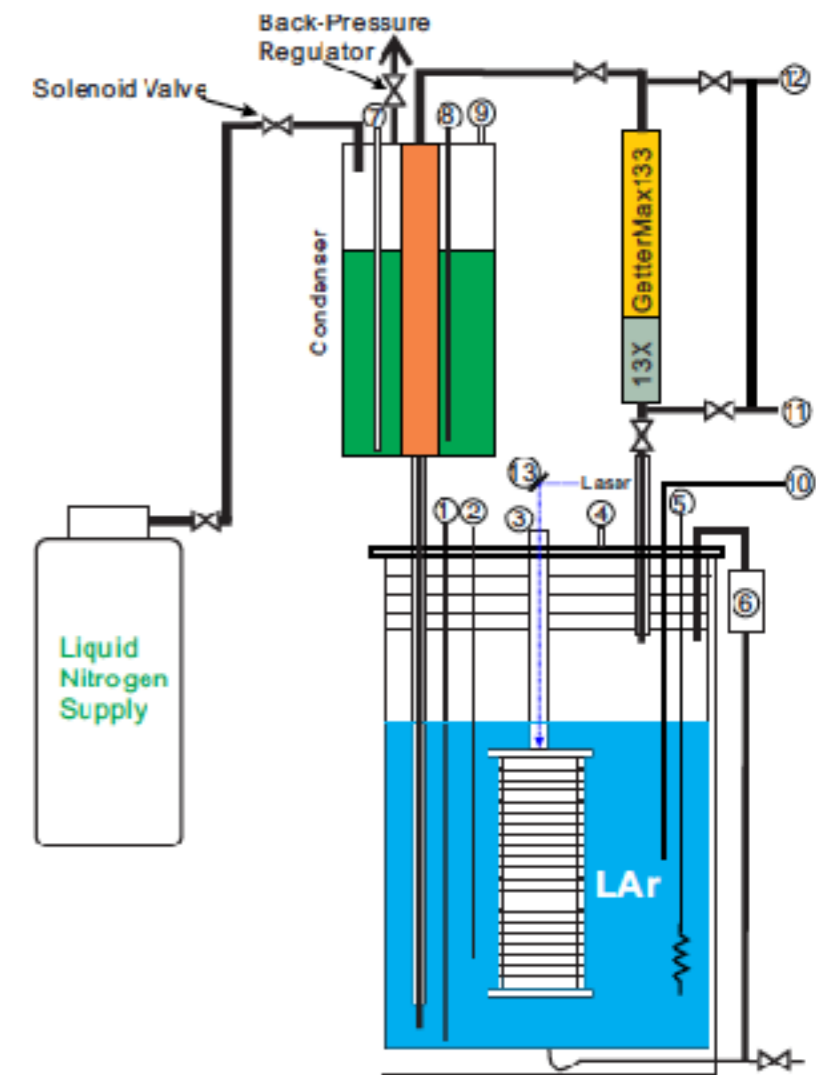

260-L LAr System Thermal Estimation

- The heat load to cryogenic system contains two parts:
 - Leak through the fiberglass insulation on top of the dewar
 - Leak into the dewar
- 20-L system heat load is calculated by model and measured
- 260-L system heat load is conservatively extrapolated as **~ 100 W**

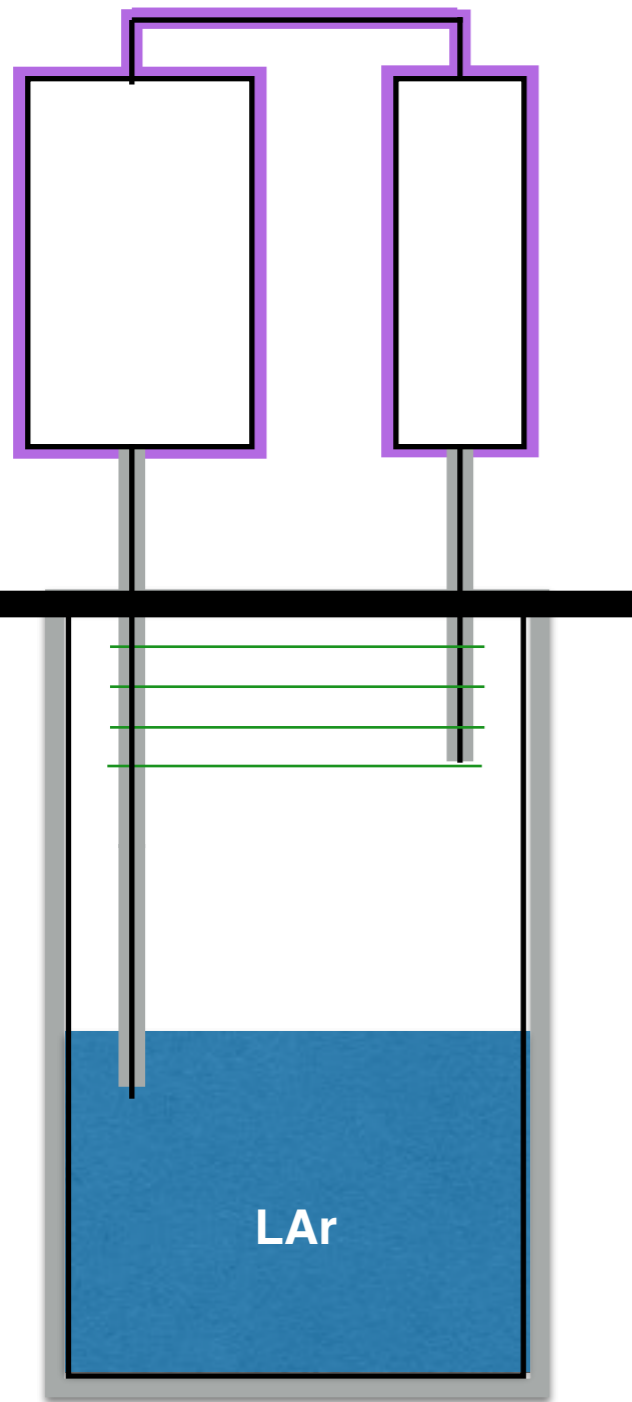

Super Insulation
 Fiberglass Insulation

Heat Source	20-L Heat Load	260-L Heat Load
Heat leak to the fiberglass insulation		
Leak thru fiberglass	12.6 W	28.0 W
Heat leak into the dewar		
Radiation from the top	0.15 W	0.64 W
Conduction thru Gas	0.1 W	0.5 W
Wall Conduction	4.17 W	9.6 W
Penetrating components	10.2 W	21.3 W
Leak through insulation	0.84 W	3.4 W
Subtotal	17.46 W	35.44 W
Total (model)	30.1 W	63.4 W
Total (measurement)	46±5 W	~ 100 W

260-L Condenser Upgrade

- To increase condensing power and minimize the LN2 consumption, we use a multi-tube design for the condenser comparing to the original 20-L. The major changes are:
 - *A single 2" OD condensing tube is replaced with multiple 1/2" OD tubes with hexagonal arrangement occupying almost full diameter of the 6"*
 - *Super insulation is added to the outside condenser*
- Condenser diameter is kept under 6" to and the height kept at ~20" (similar to 20-L system)
- The thermal contact area is increased by ~7x of the 20-L condenser
- The performance of the new condenser has been demonstrated with the stable cryogenic operation of the 260-L system

20-L condenser

Max. condensing power
tested
200W

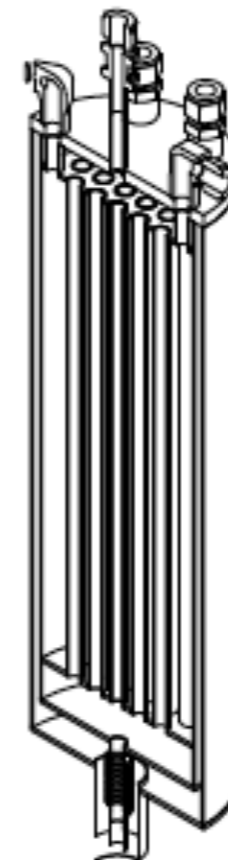
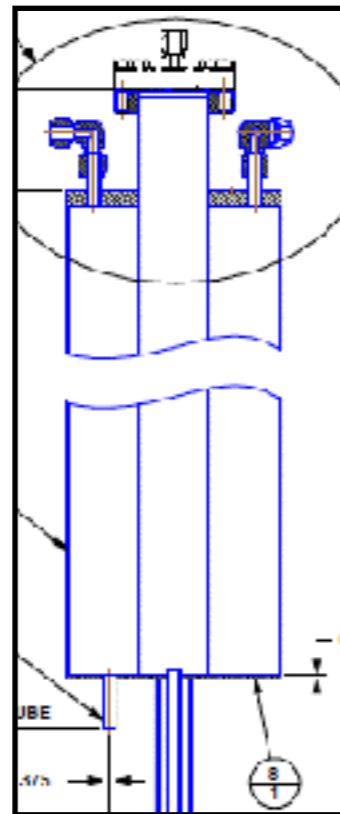

260-L condenser

Max. condensing power
estimated
~ 1400W

260L LAr System

► 260 L LAr system introduction

- Main dewar has a volume of 260 L with 22" ID and ~47" Height
- Purification in gas phase only with 13x Molecular Sieve+Copper Catalyst to remove water and oxygen
- Commercial LAr supply has a purity level at ppm level
 - Single-pass filtration at filling with commercial LAr can reduced the purity to 10^0 ppb level with an inline filter
 - Performance tested in 20-L and 260-L
- LArTPC measurement requires sub-ppb level purity for sufficient electron lifetime
 - A purity monitor is implemented in the system this run
 - Maximum purity for PrM reading is ~10 ppb

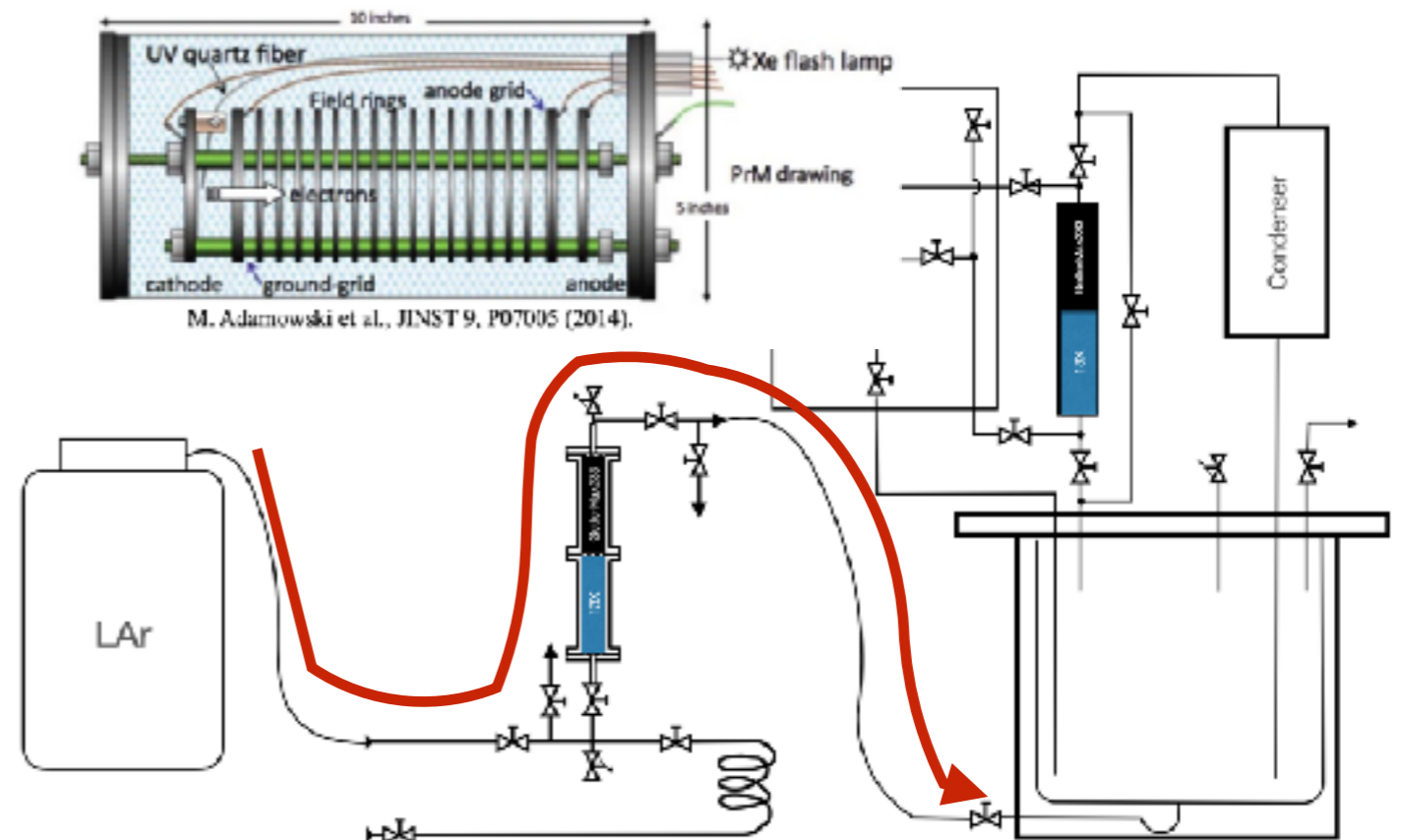

Purity Monitor

- Purity monitor (PrM): Miniature TPC measuring drifting electron lifetime with photoelectrons.
- UV from Xenon flash lamp to generate photoelectrons on PrM gold photocathode
- Use anode-to-cathode charge ratio to measure drift electron lifetime:

$$Q_{\text{anode}}/Q_{\text{cathode}} = e^{-t_{\text{drift}}/\tau}$$

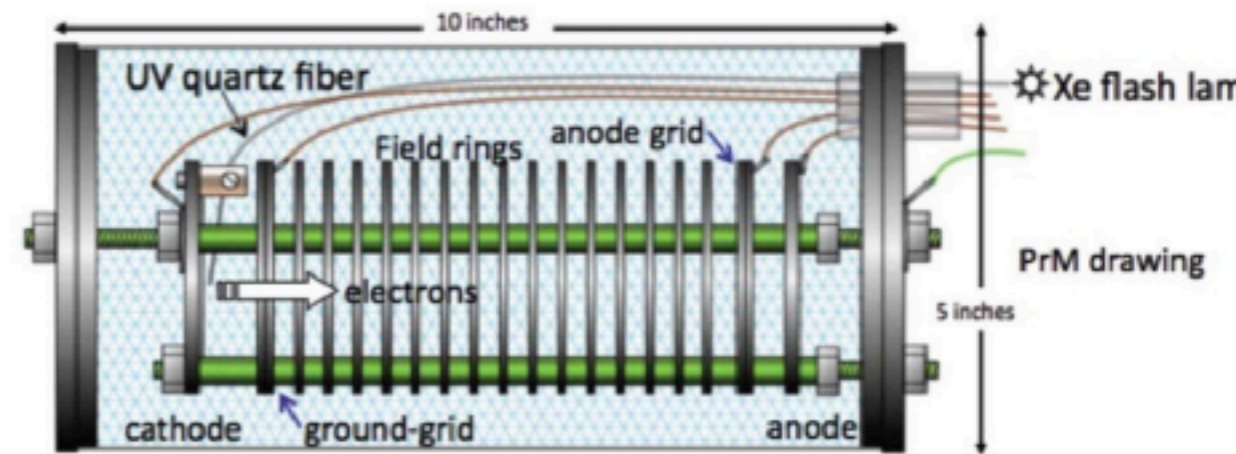

M. Adamowski et al., JINST 9, P07005 (2014).

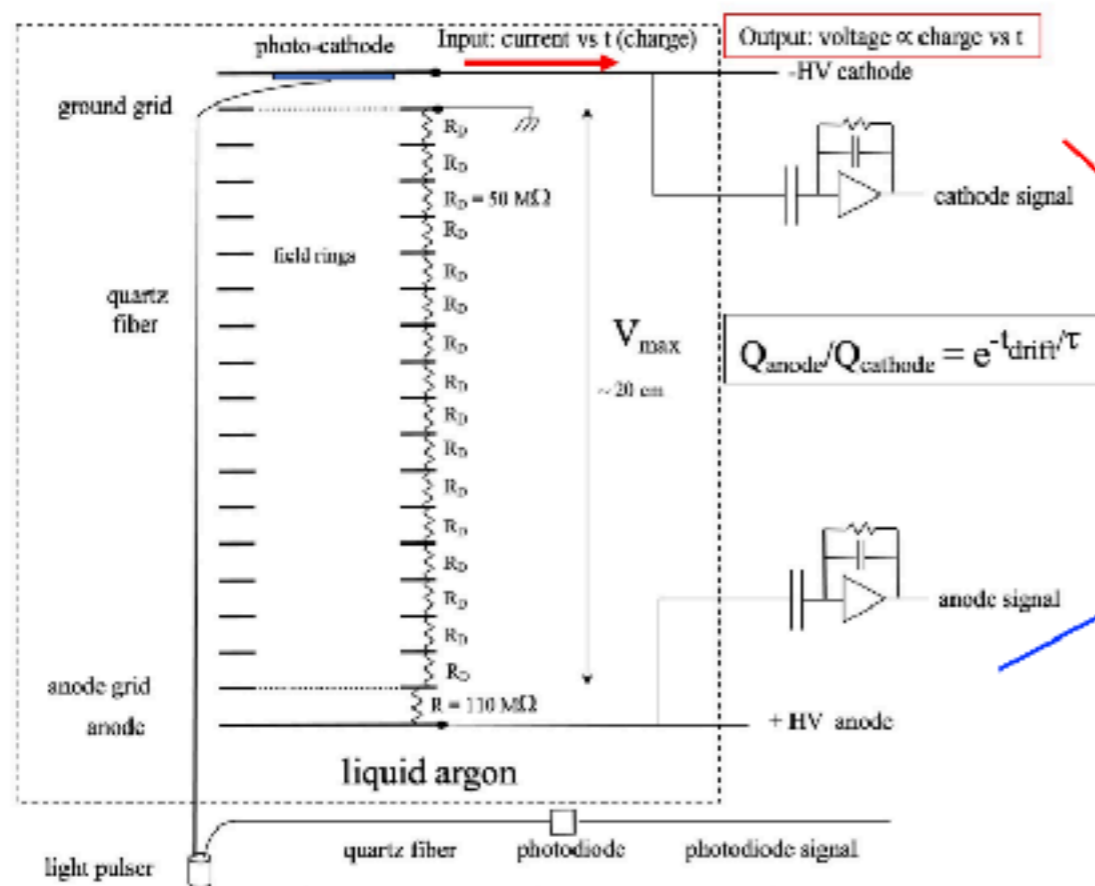
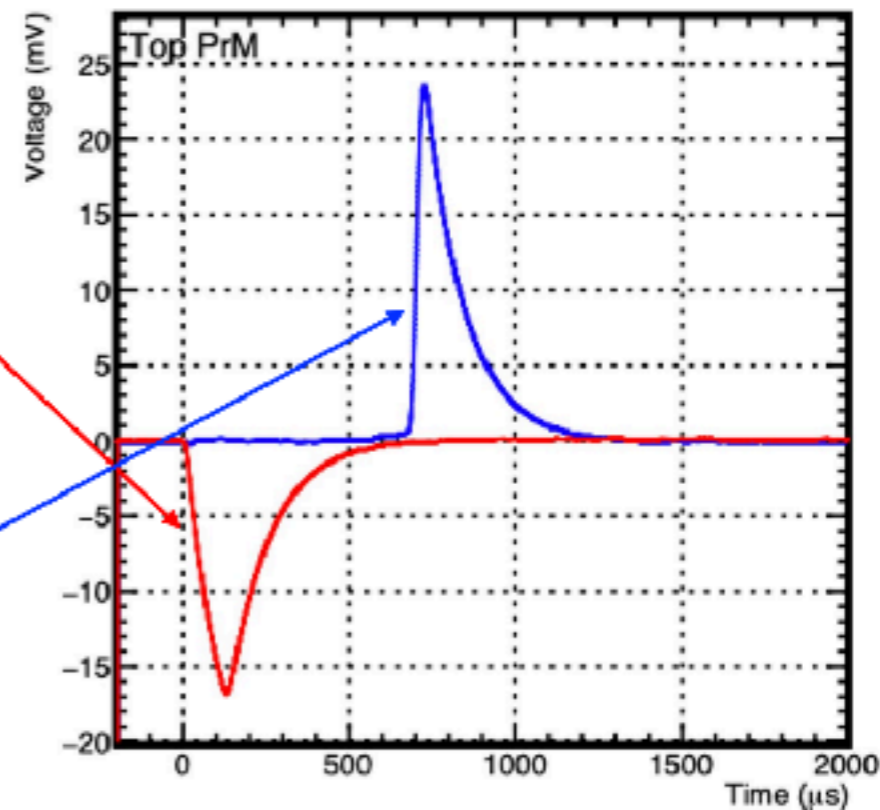

Diagram: G. Carugno et al., NIM A292 (1990) and ICARUS-TMN2-14



Purity monitor Cathode and anode signals in ProtoDUNE-SF

3

260 L LAr System Status

► 260L LAr Filling

- Started on April. 4th, 11 days cryogenic operation til now, filling takes about 5 hours
- Used ~1.5 full LAr supply dewar to immerse the PrM with a filling level of ~42%, ~110L LAr in the main dewar
- PrM performance test in GAr before and during filling when the bottom part liquified
- Cryogenic running pretty stably so far with LN2 filling cycle of ~ 1hr



260L LAr System Purity Performance Preliminary Results

► Purity Performance

- The PrM was run in vacuum and GAr with the functionality validated
- No signal right after the fill
- Started to observe the charge signal on anode on the day 5
- The estimated purity is ~ 0.90 ppb with electron lifetime ~ 0.3 ms at 500V/cm, sufficient for physics measurement
- High purity can be achieved with gas purification

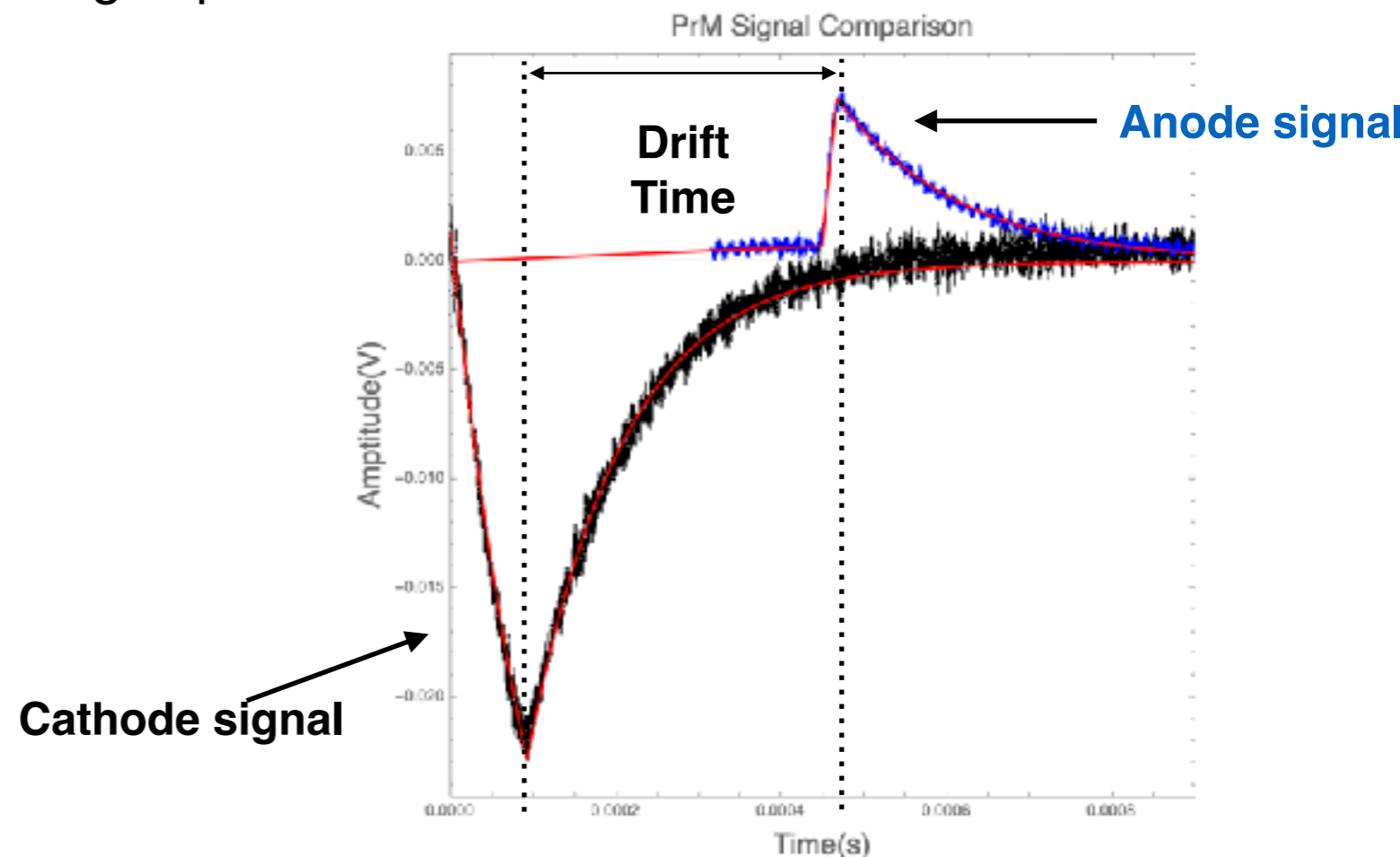
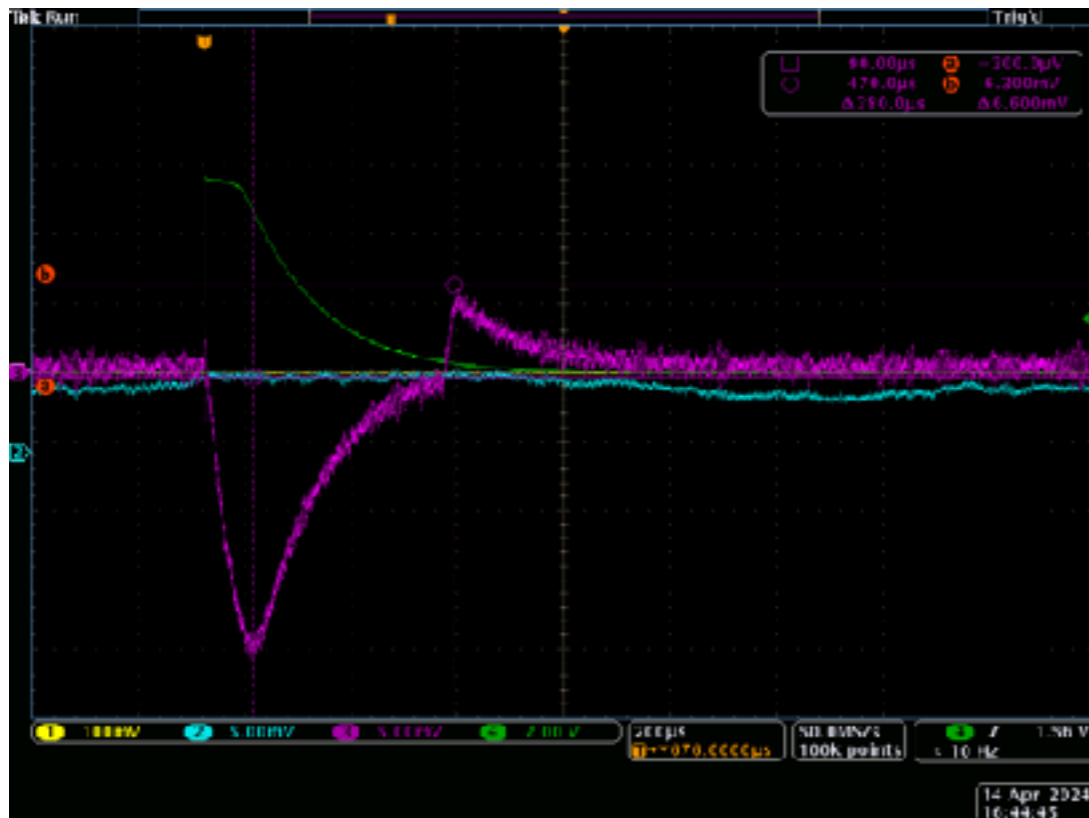

Reference Design: Darkside-20k

- ▶ **Darkside-20k has implemented the gas purification cryogenic system**
 - Fiducial volume of 20 ton, 50 ton active volume, similar scale as FLArE (~32 ton fiducial)
 - Gas purification only with liquid nitrogen cooling with a multi-tubing condenser
 - The performance has been demonstrated in Darkside 50
 - Condensing power can be increased with additional tubings
 - Circulation is driven by a gas pump
 - Existing engineering design and infrastructure tested at CERN

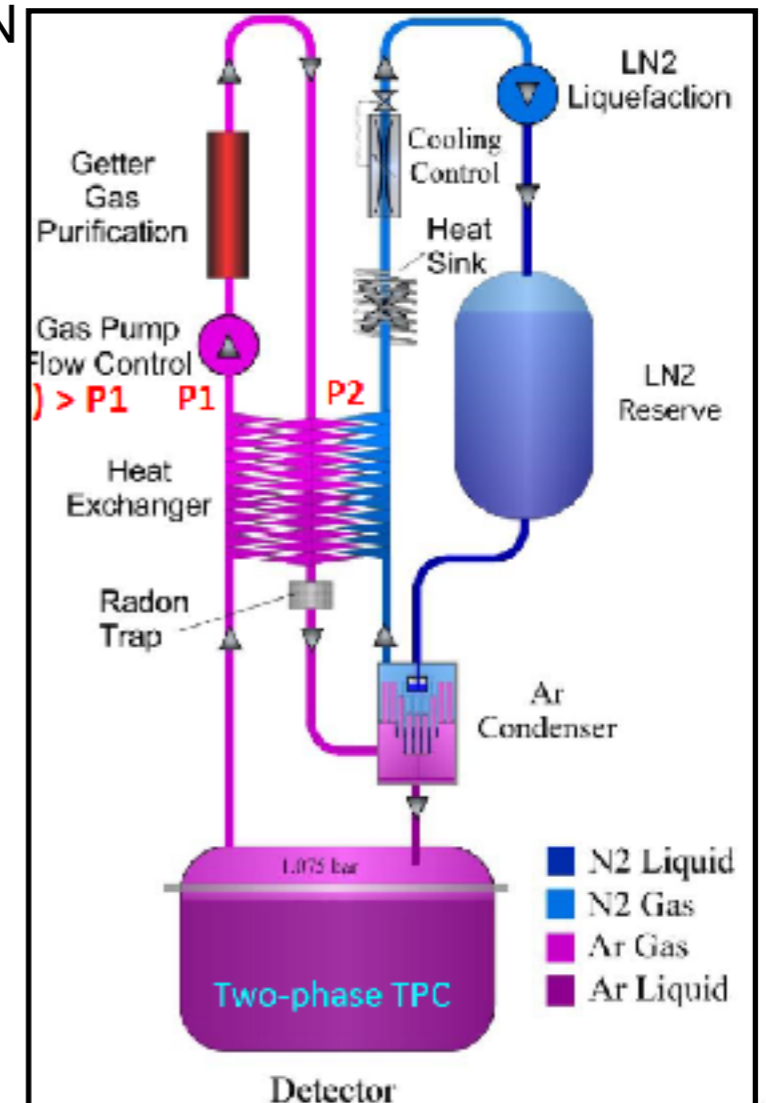
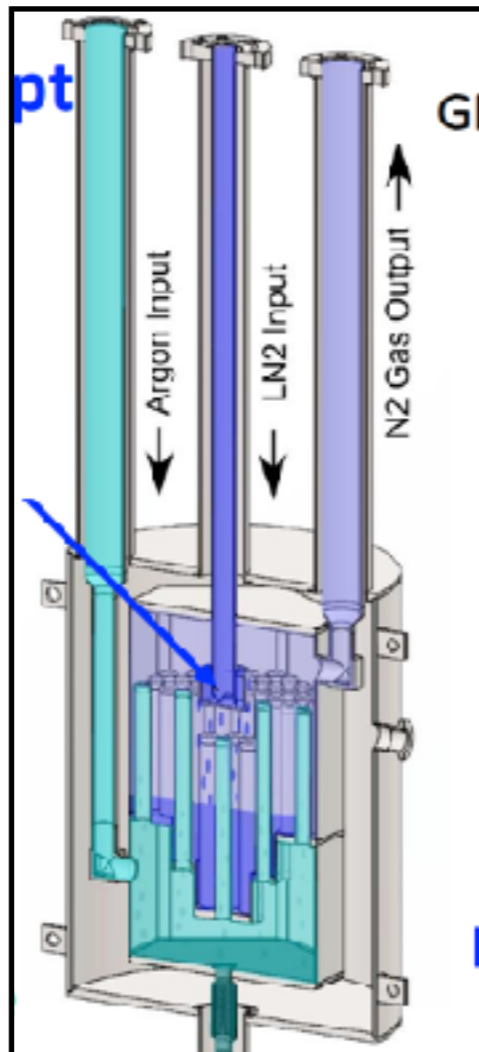

Reference Design: Darkside-20k

- System designed with 10 kW cooling power
- FLArE heat budget is estimated to be close to 10kW using MicroBooNE cryogenic
- Darkside cryogenic can be another reference design

Closed argon loop with gaseous compressor highlighted

DarkSide 20K Test Cryogenic System
04.13.22

© HGW Photos

LN₂ supply line

LN₂ phase separator

Gaseous Ar compressor

Coldbox - condenser and gaseous phase heat exchange

N₂ control

LAr lines

Cryostat

Control, monitoring, and DAQ

Cold gas return

From Tom Thorpe

Summary

- Gas purification removes impurities at the source
- Initial inline filtration can improve the purity of LAr from ppm level to 10^0 of ppb level
- LAr cryogenic system can achieve high purity with gas purification
- The performance of the gas purification system has been demonstrated on a similar scale in Darkside
- Gas purification driven by a gas pump can be an alternative design, no cryogenic liquid pumping needed

Back up

Introduction: Existing Test Stands

- Two LAr test stands with small scale have been built at BNL
- The 20-L system has demonstrated the effectiveness of the gas purification during the operation and a high purity of < 1 ppb in terms of H₂O and O₂ concentrations has been achieved
- The LArFCS is an upgrade of the 20-L system with similar cryogenic scheme with a main dewar volume of 260 L

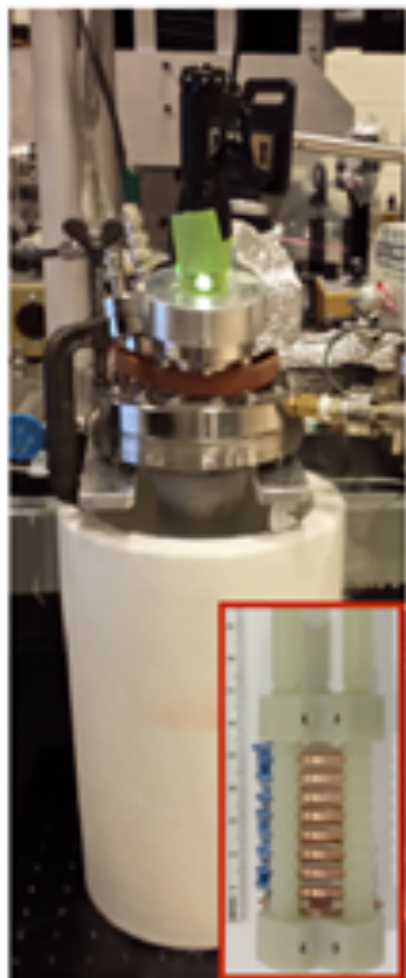

2L Test Stand



20L Test Stand



LArFCS (~260L)

Condenser Mechanical Design

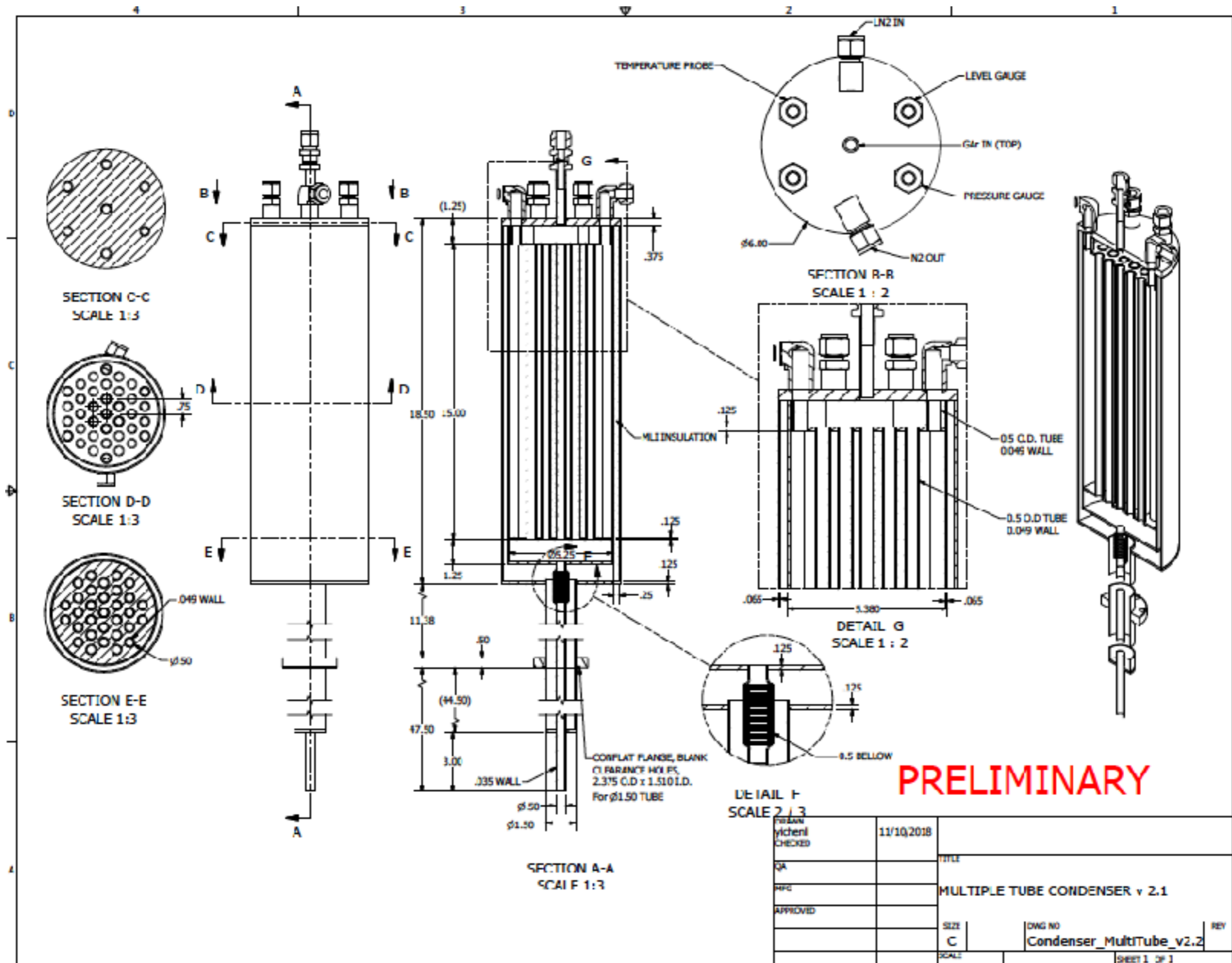

ProtoDUNE Cryogenic

- ▶ **Standard Membrane Insulation used**
 - No cold shields

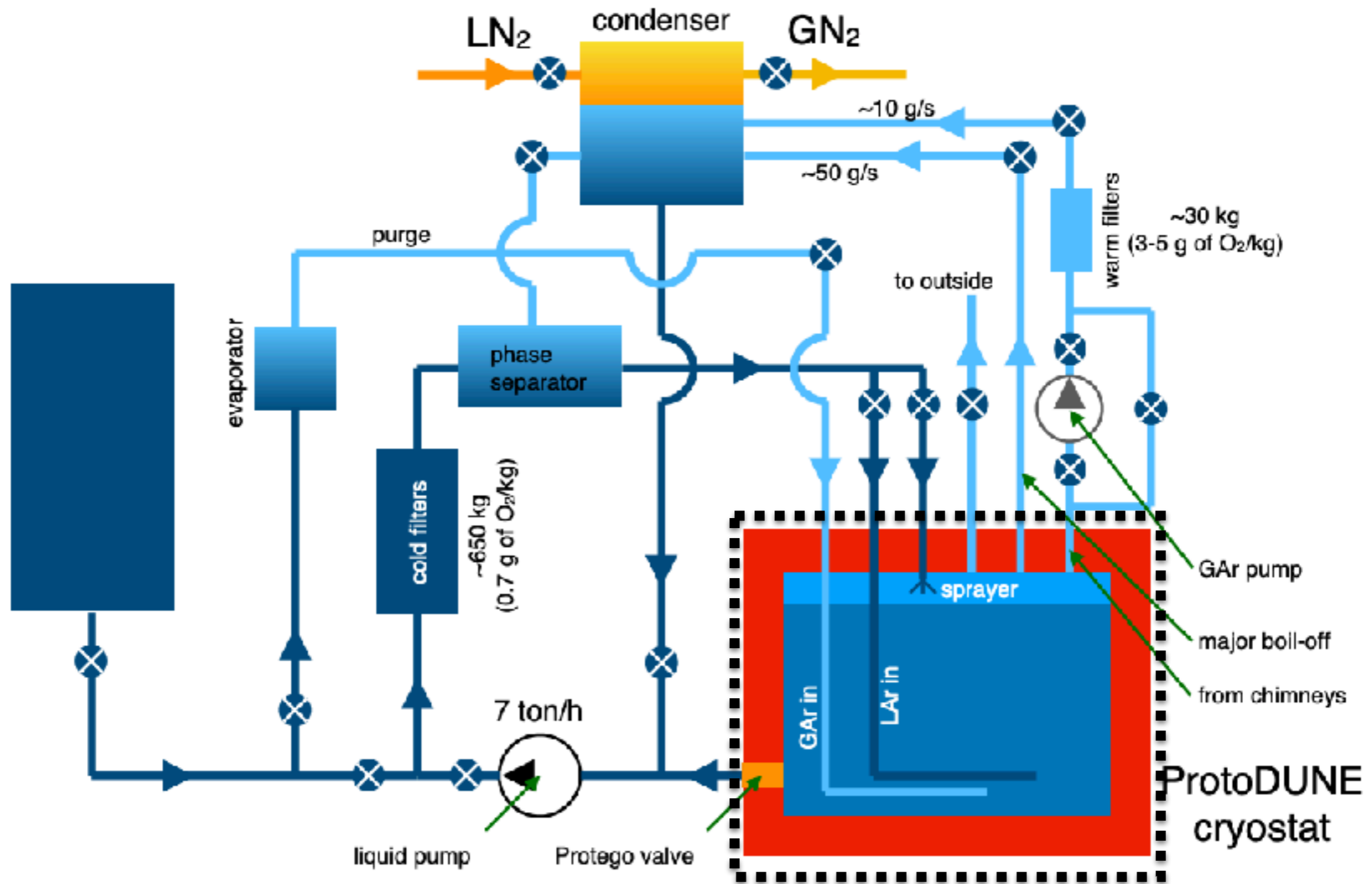

Outside of Hall-C

Liquid Nitrogen Plant

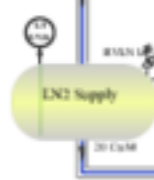

DarkSide 20K UAr Cryogenic System

November 4, 2022

Not To Scale

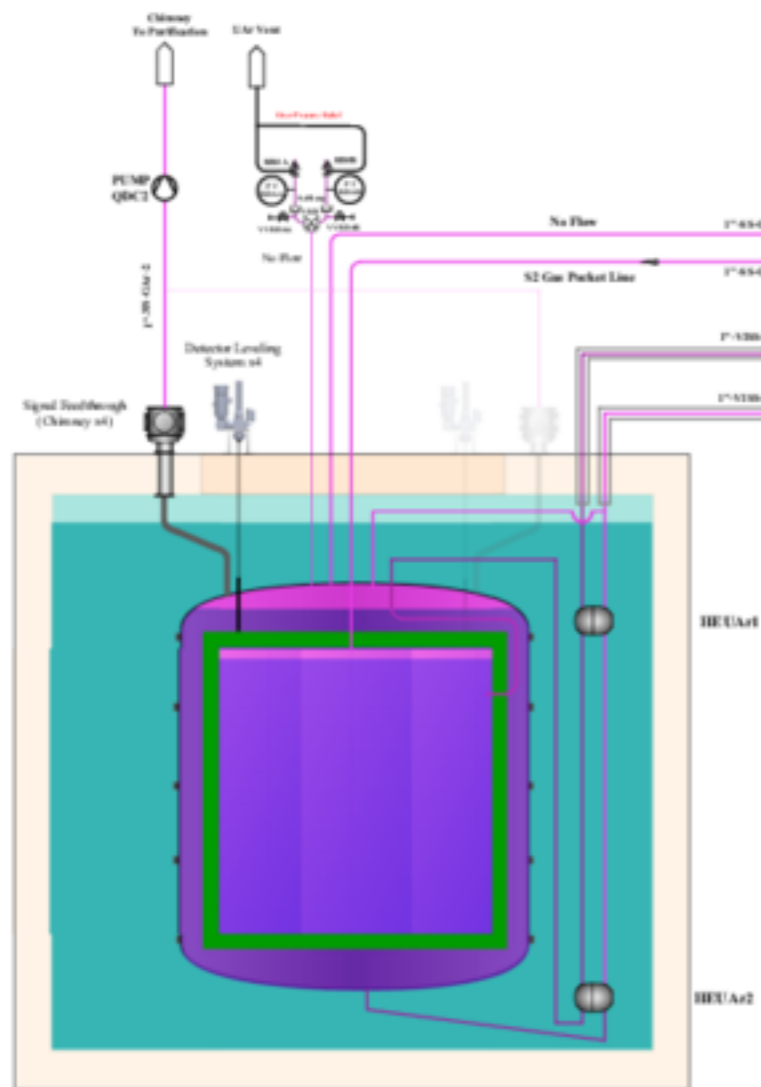

- Nitrogen Liquid
- Nitrogen Gas
- Depleted Argon Gas
- Depleted Argon Liquid
- Atmospheric Argon Gas
- Atmospheric Argon Liquid
- Vacuum
- Gd-PMMA

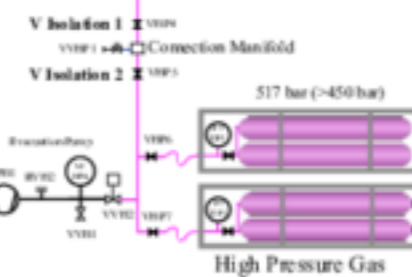
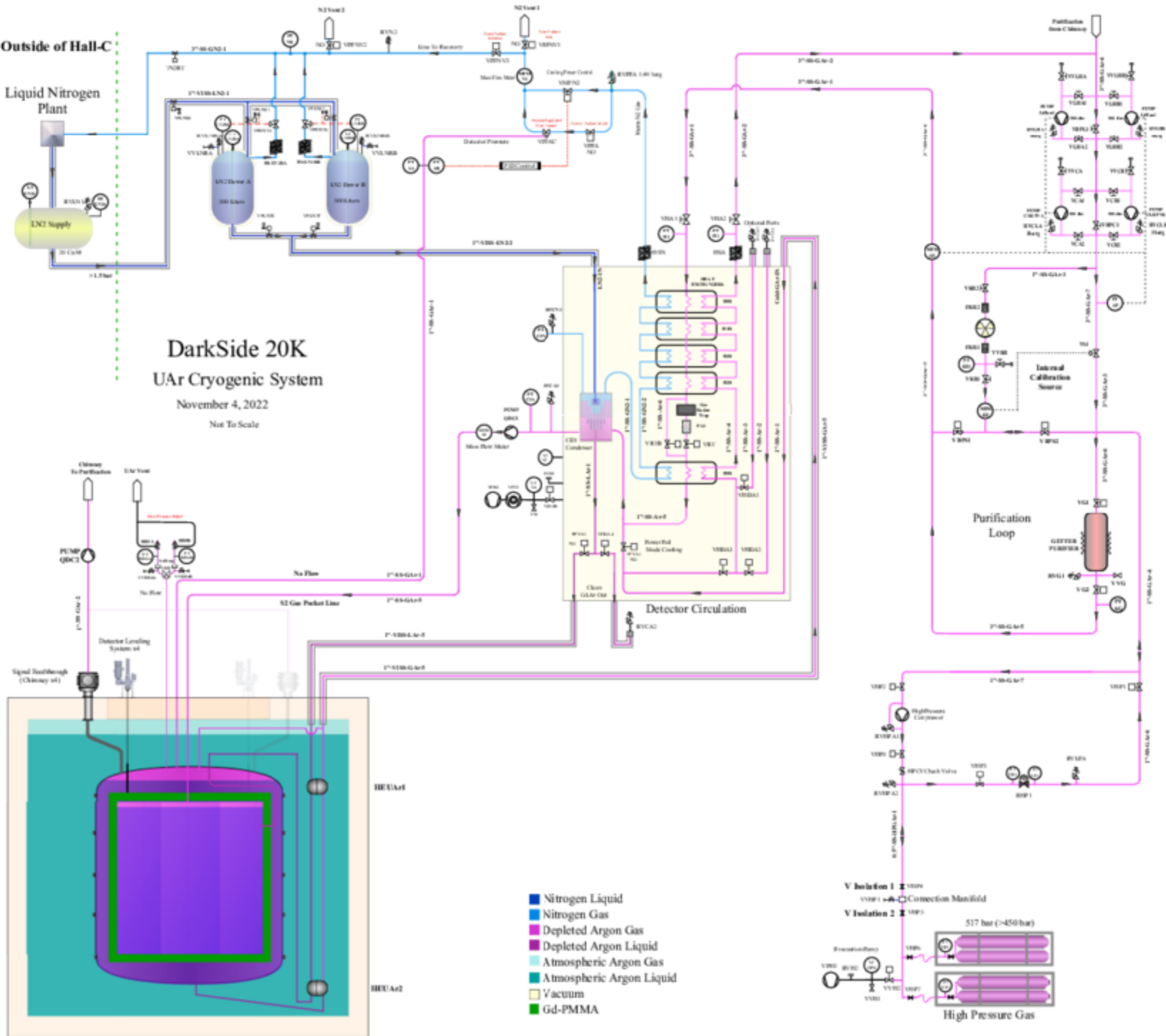

DarkSide 50 Cryogenic System (Simplified)

