

New Approaches on Dark Matter Detection

Tien-Tien Yu (University of Oregon)

IAS Program on High Energy Physics (HEP 2023)

February 16, 2023

Dark Matter Exists

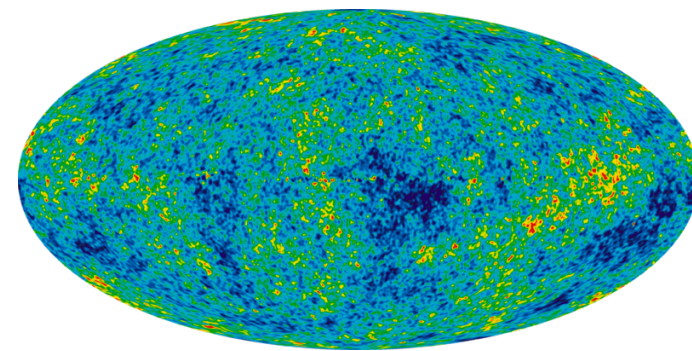
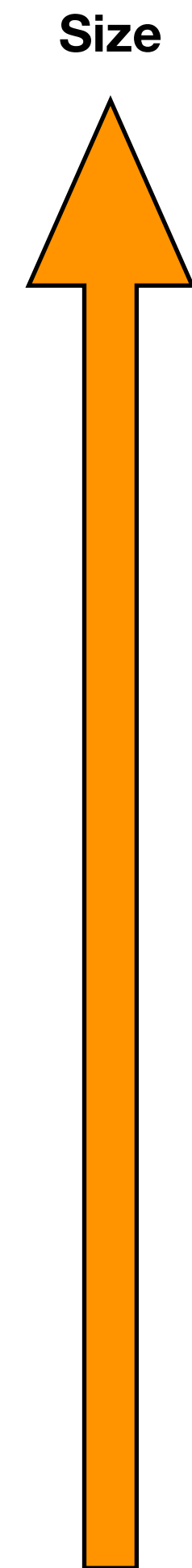

COSMIC MICROWAVE BACKGROUND

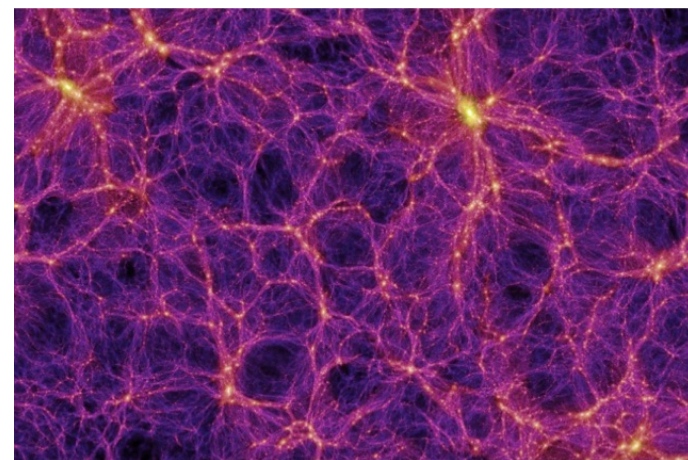

LARGE SCALE STRUCTURE

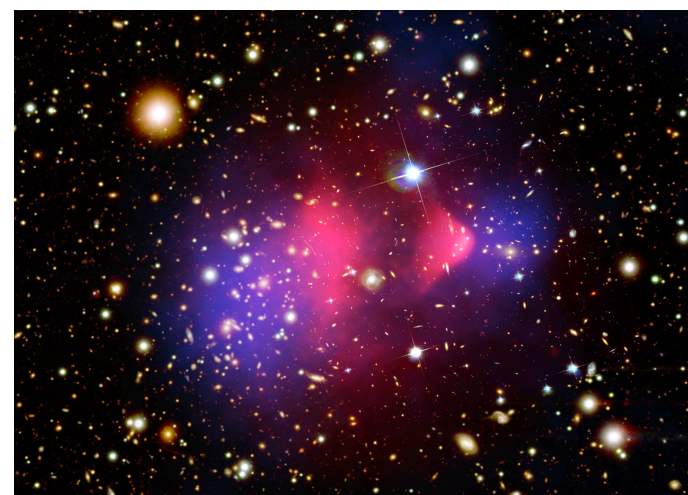

GALAXY CLUSTER MERGERS

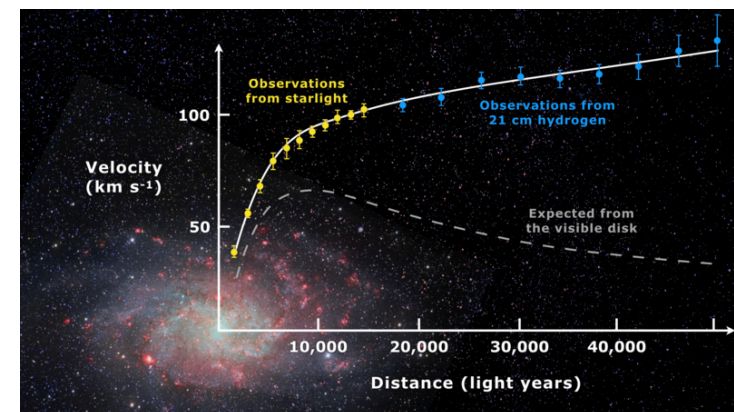

GALACTIC ROTATION CURVES



Gravitational interactions

Dark Matter Candidates

Gravitational interactions \longrightarrow massive (particle)

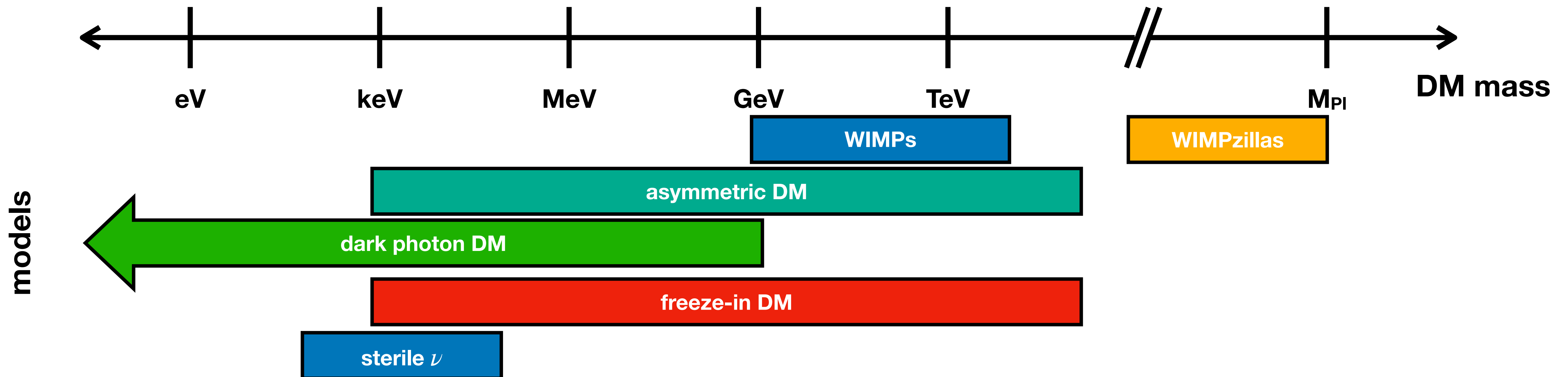

Many theoretically-motivated models!

Non-gravitational interactions of DM

Probing all of these interactions is crucial for understanding the **particle** nature of DM

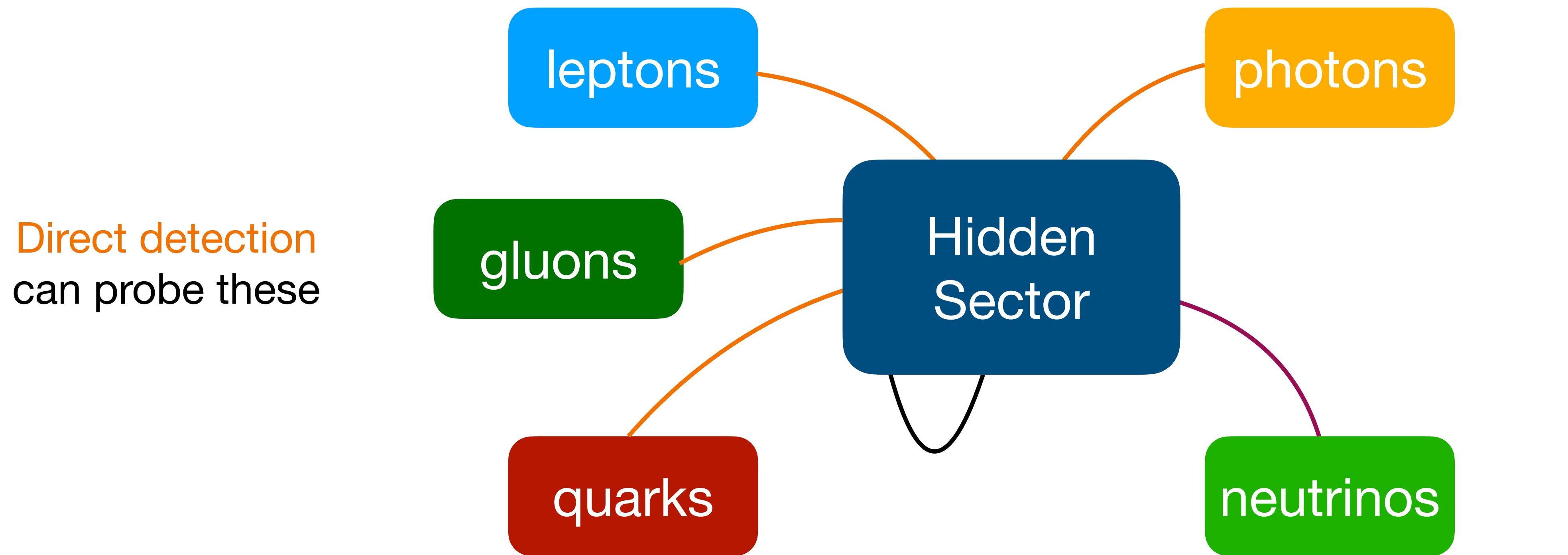

Direct detection
can probe these

Direct detection probes our galactic dark matter halo

Dark Matter Direct Detection

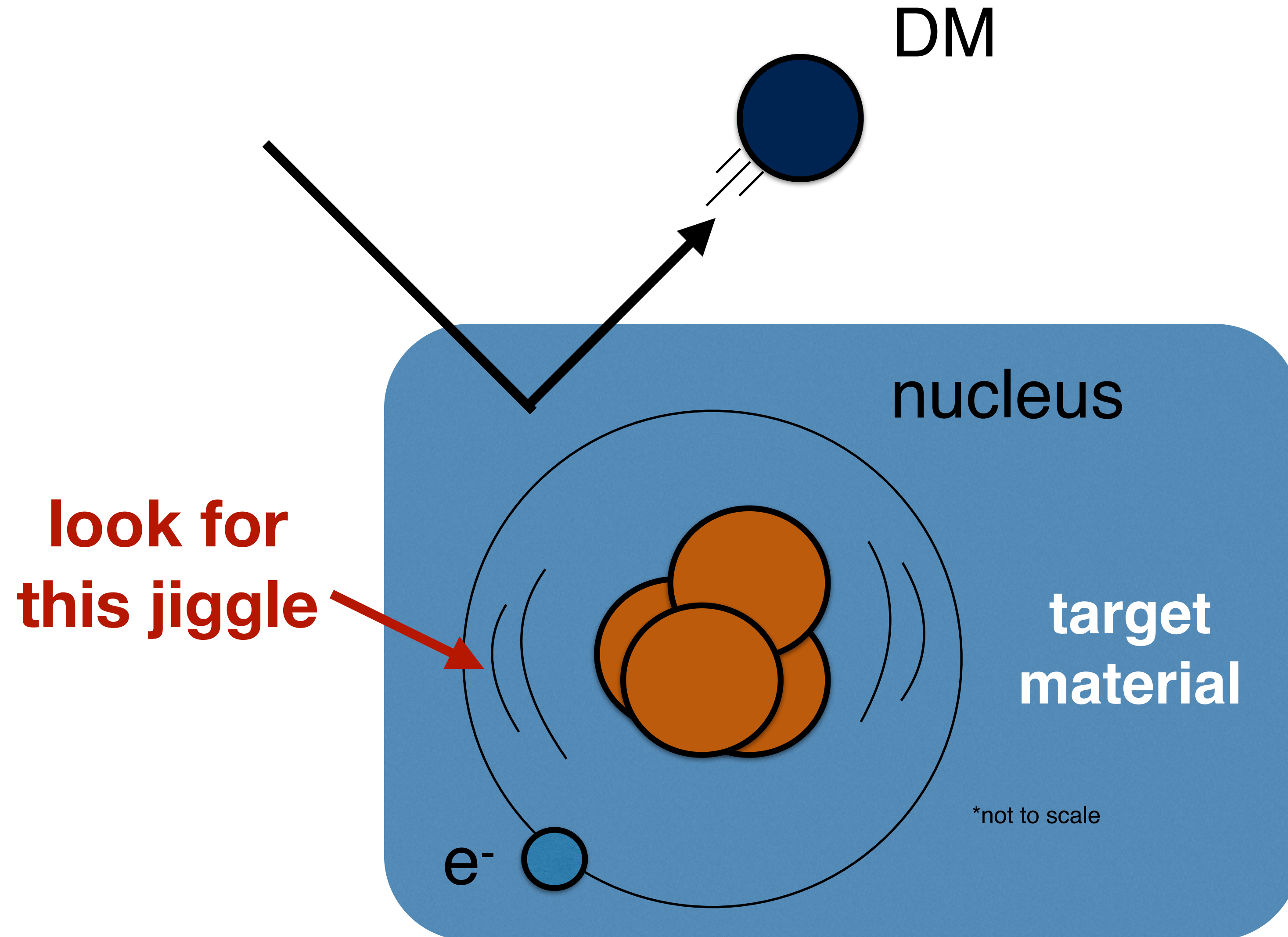

Dark Matter Direct Detection

somewhere deep underground

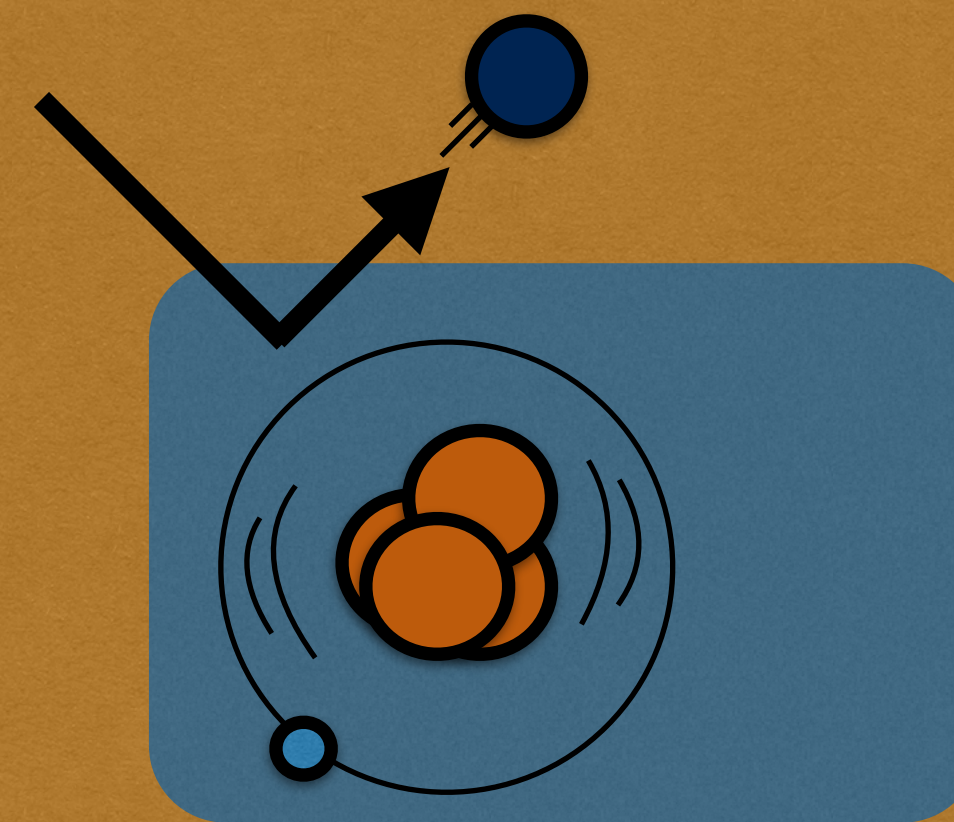

Dark Matter Candidates

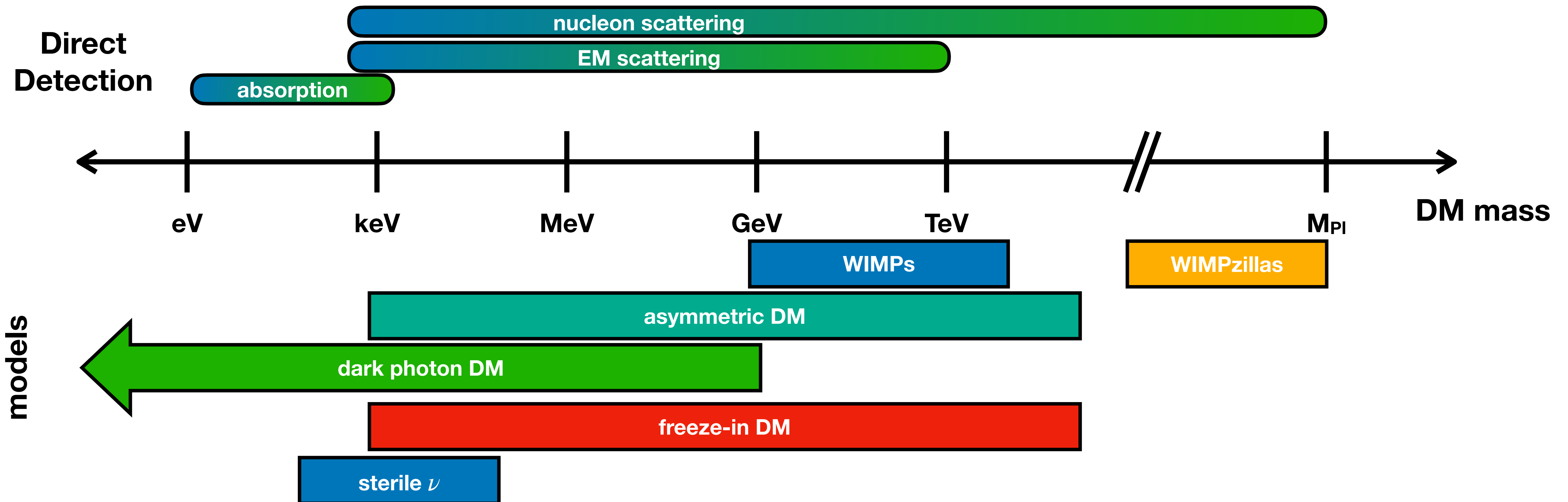

Landscape of Particle Dark Matter

- consider ensemble of interactions

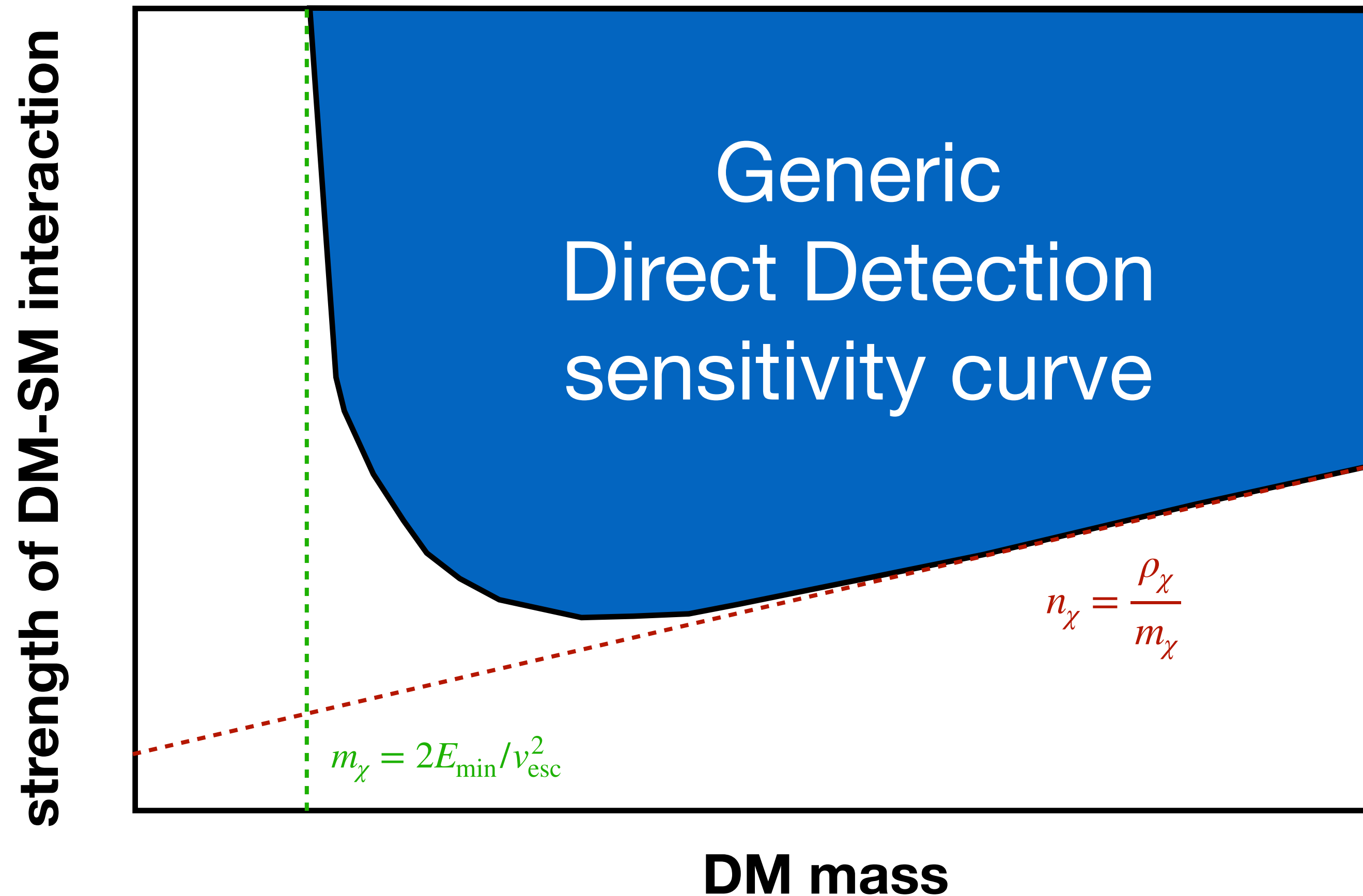

GOAL:
explore
this space

- increase target mass
- improve background discrimination

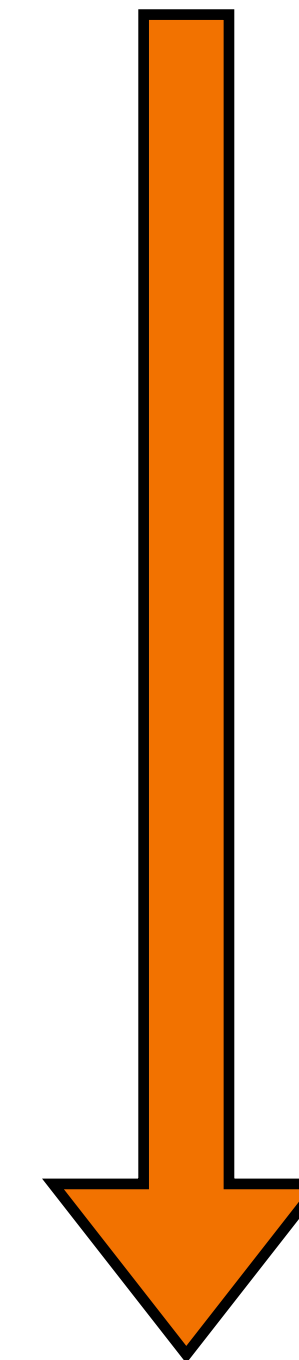

- decrease thresholds
- increase energy transfer



Dark Matter Candidates

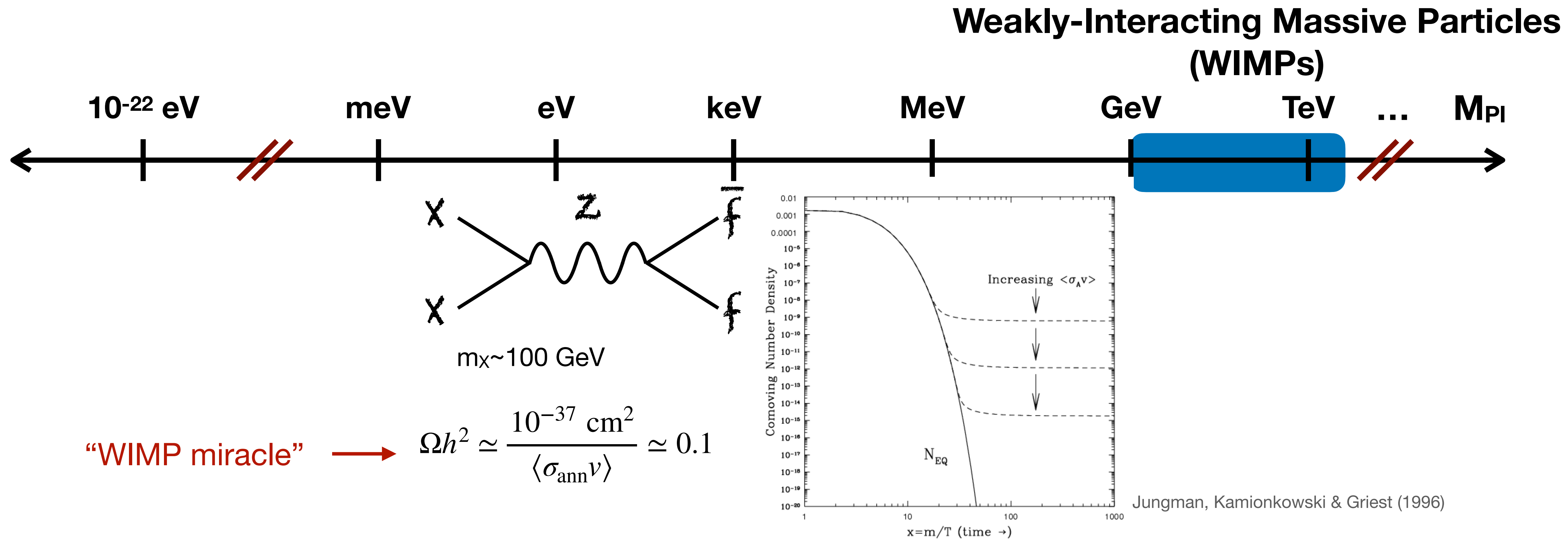

Current Landscape: Spin-Independent

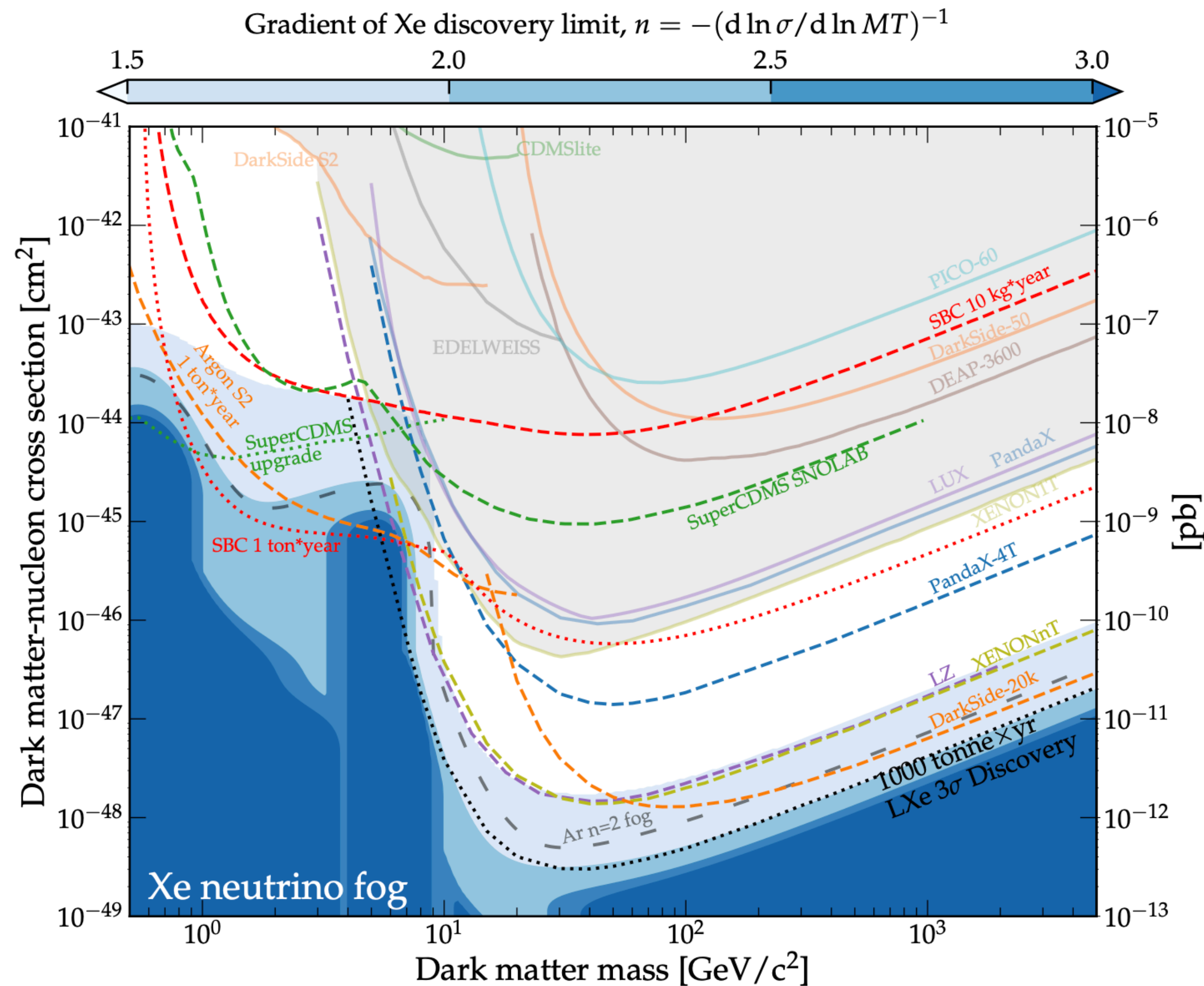

Snowmass2021 Cosmic Frontier Dark Matter
 Direct Detection to the Neutrino Fog
 [arXiv: 2203.08084]

Path towards DM discovery

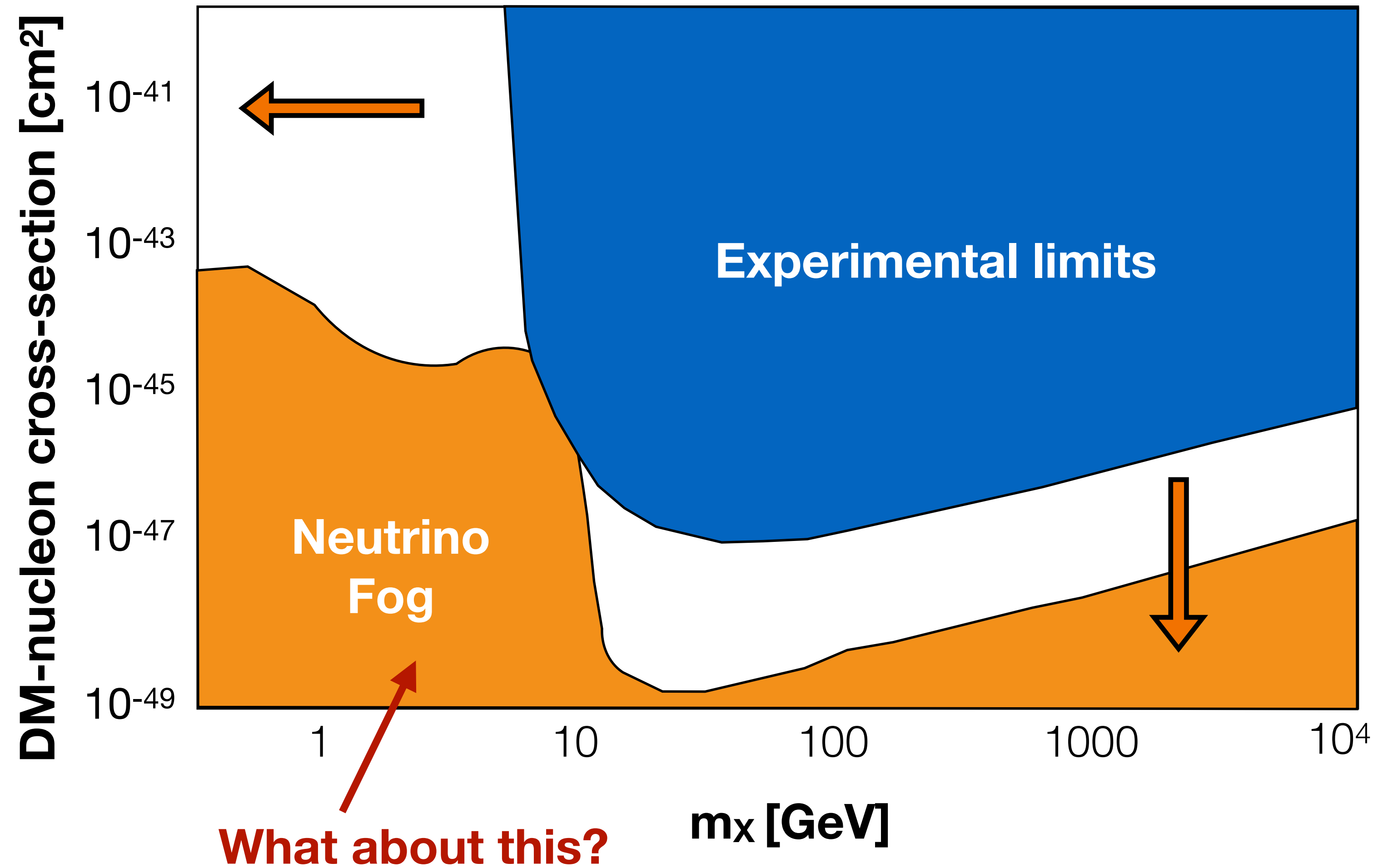

Goals:

- increase target mass
- decrease thresholds
- improve background discrimination

New technologies:

- Supercooled detectors
- Low Background DUNE-like module
- Giant gas TPCs in pressurized caverns
- ...

Navigating the Neutrino Fog

Snowmass2021 Cosmic Frontier Dark Matter

Direct Detection to the Neutrino Fog

[arXiv: 2203.08084]

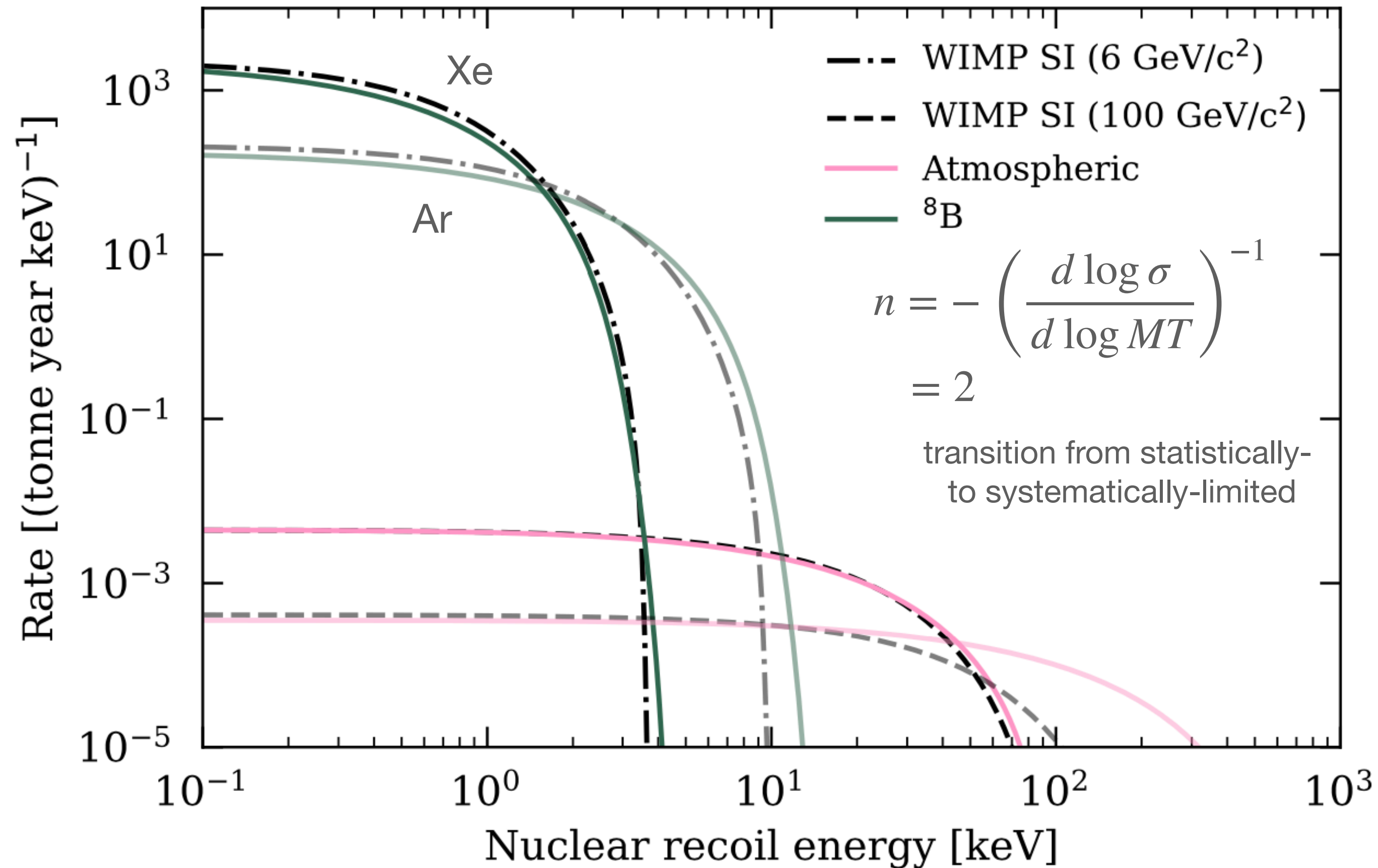

Mitigation techniques:
annual modulation
directional detection

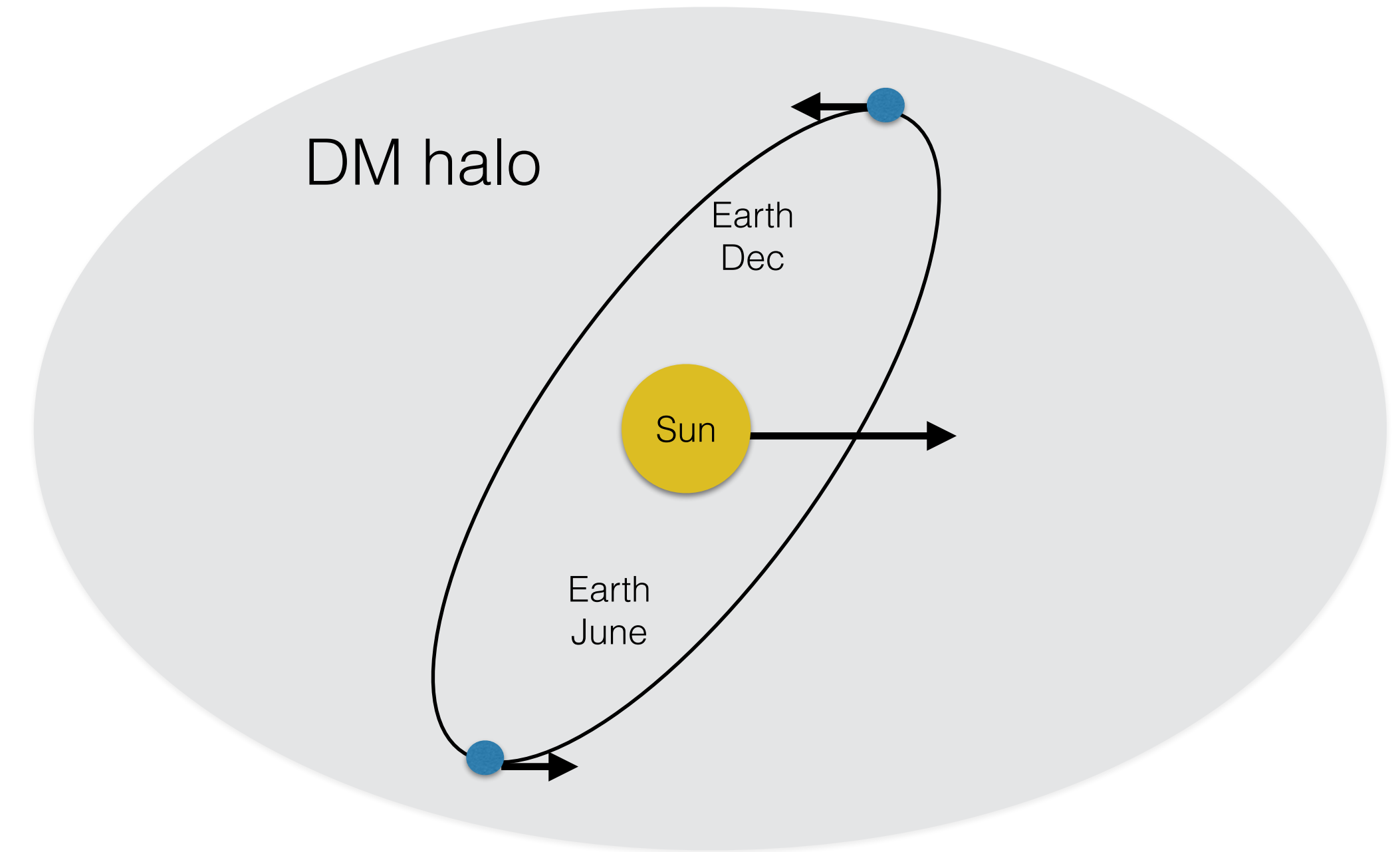

changes rate as a function of time
signature of **galactic** dark matter

Directional Detection

Very distinct signature!

Requires ability to reconstruct direction of nuclear recoil

Vahsen, O'Hare, Loomba, [arXiv: 2102.04596]

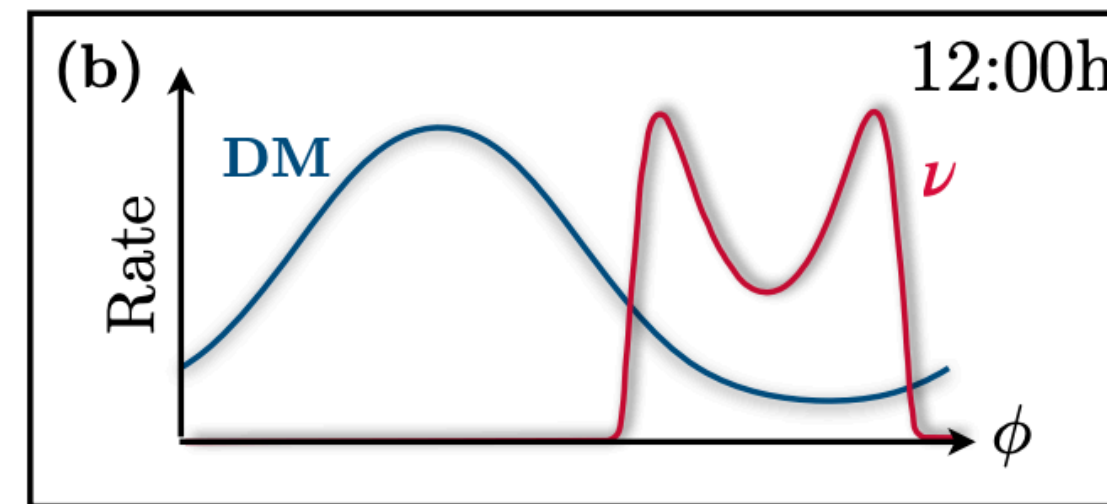
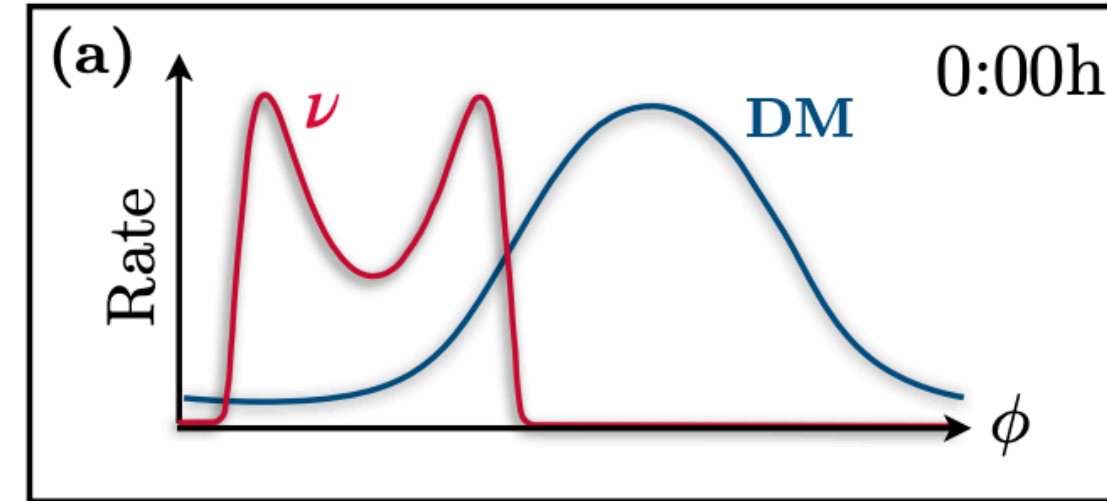
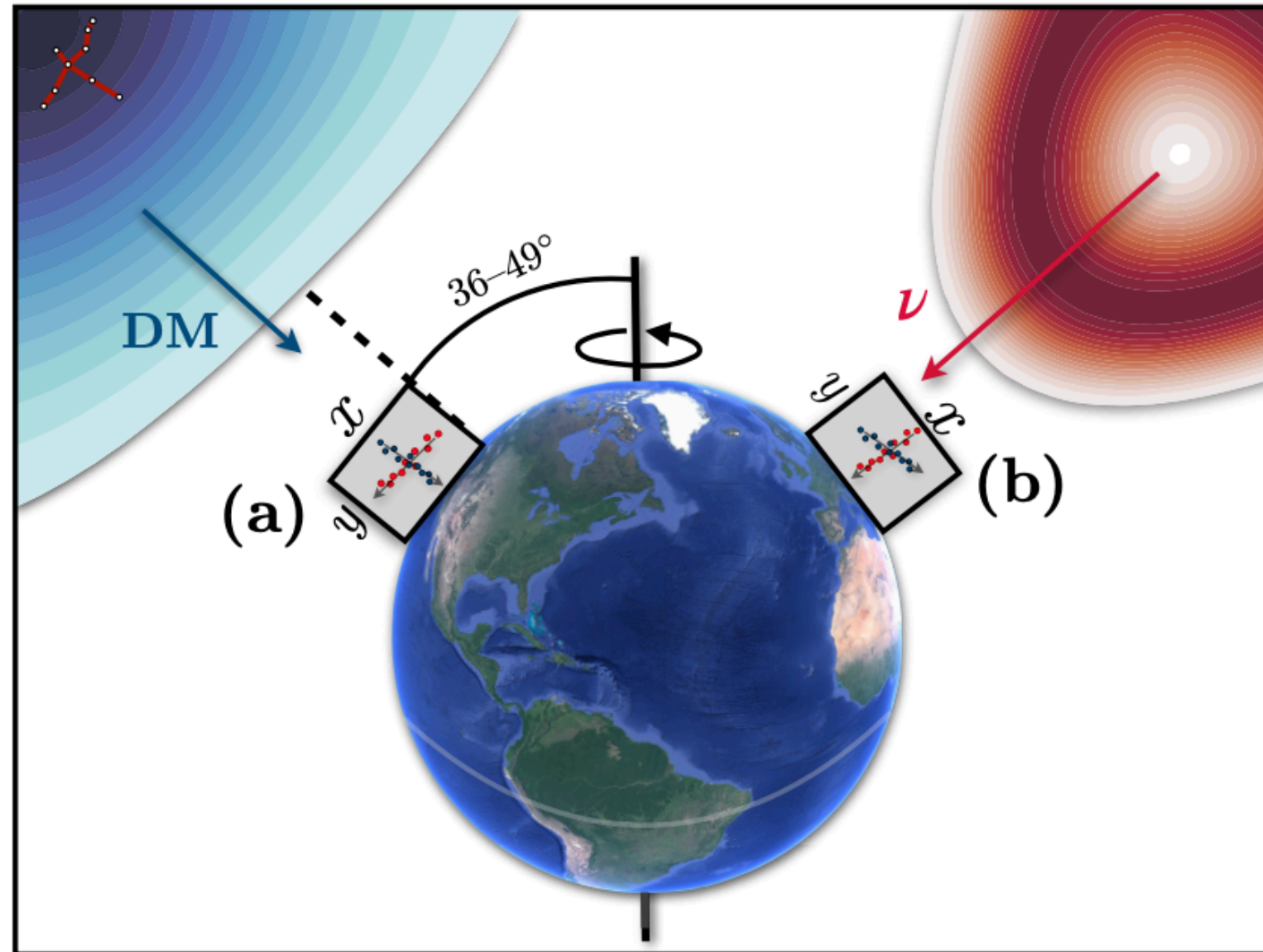

Can also provide information on dark matter **substructure** in the galactic halo!

Physics case for a directional gas TPC

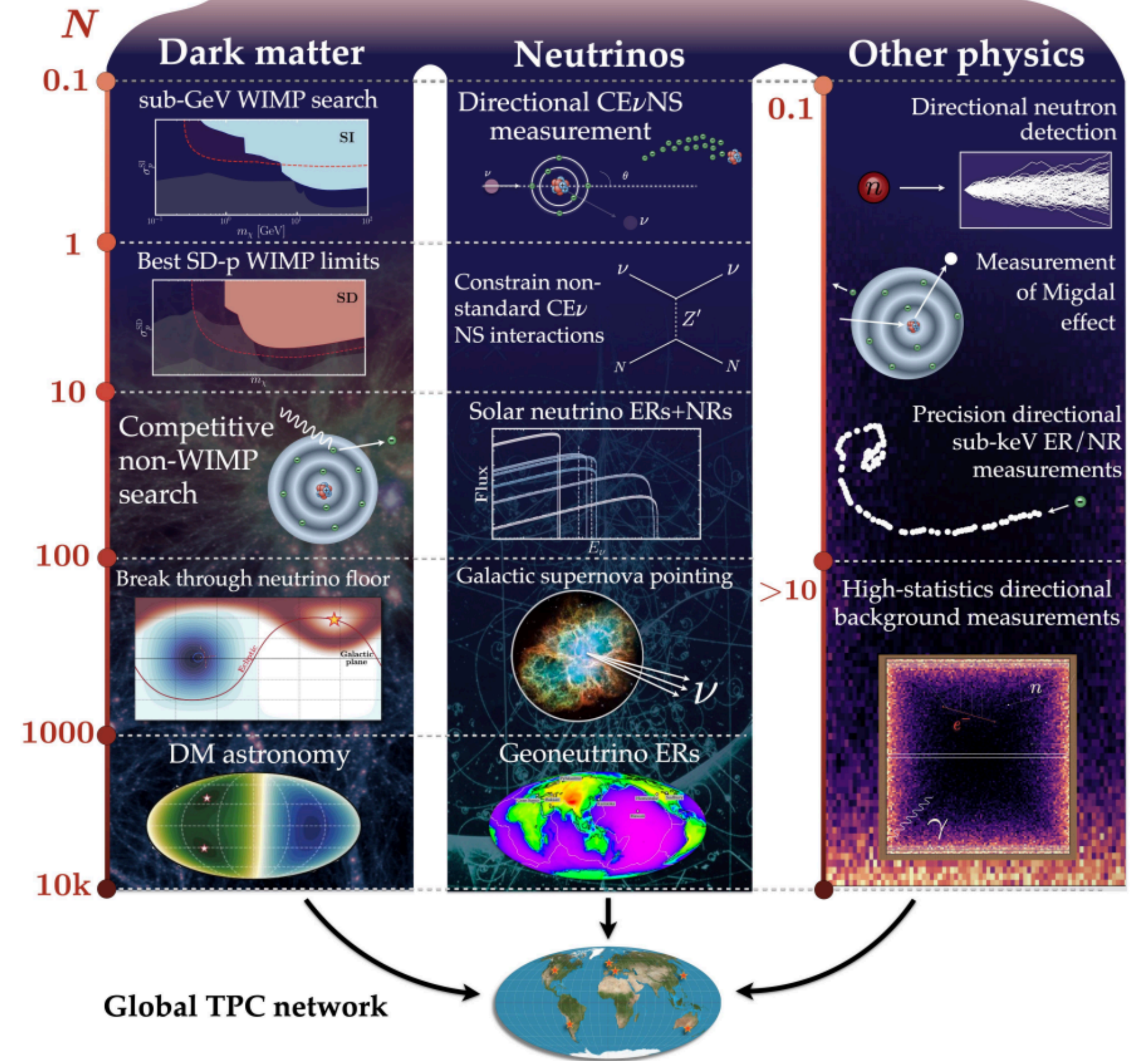
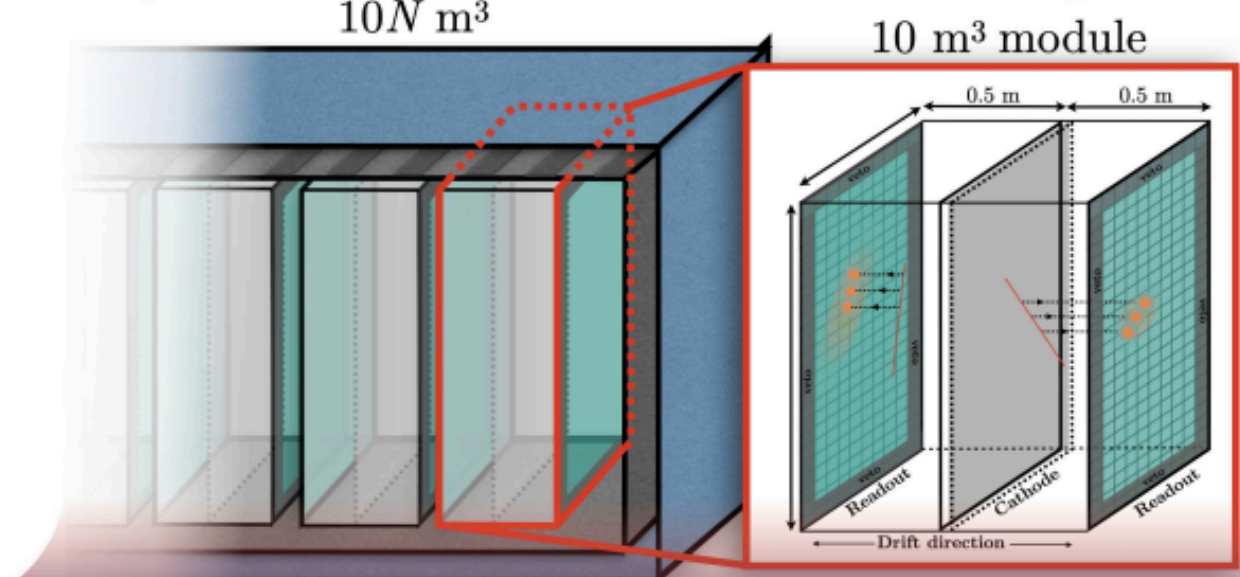

Landscape of Particle Dark Matter

- consider ensemble of interactions

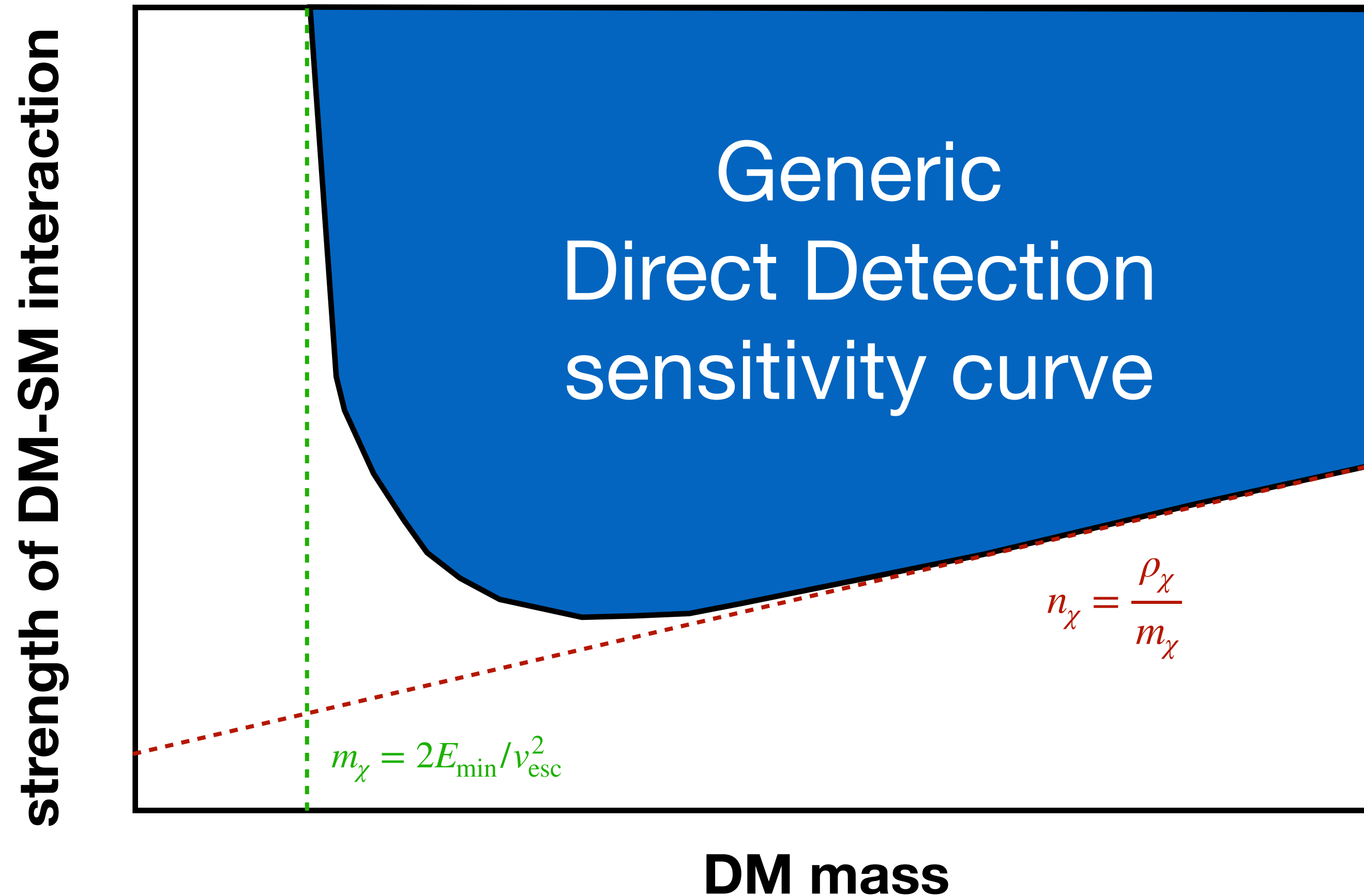

GOAL:
explore
this space

- increase target mass
- improve background discrimination

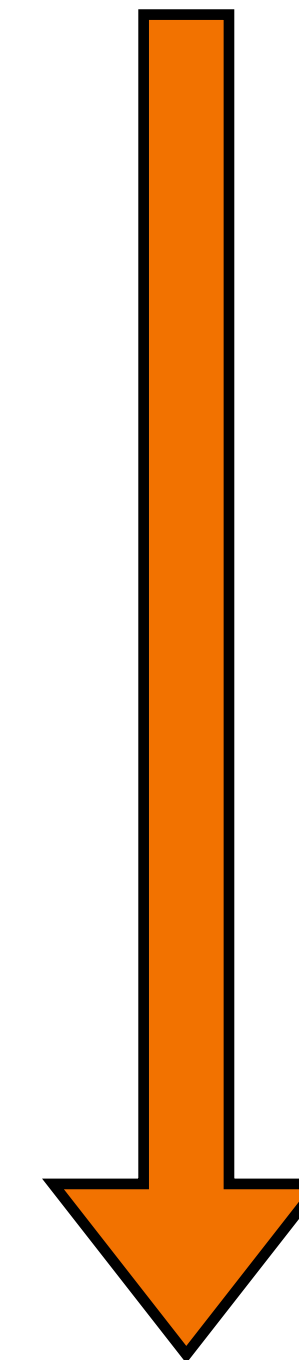

- decrease thresholds
- increase energy transfer



Dark Matter Candidates

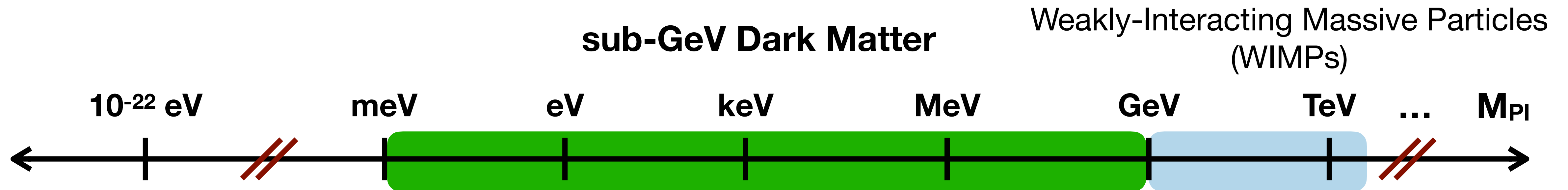

Lee-Weinberg bound
Thermal DM

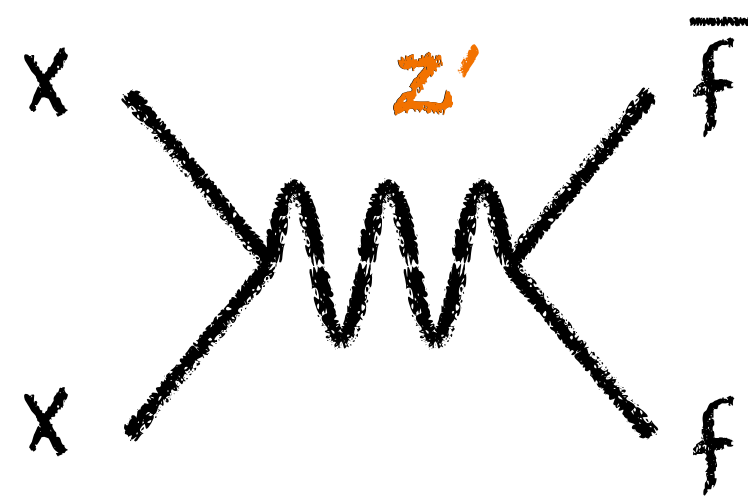

$$\Omega_X h^2 \lesssim 0.1$$

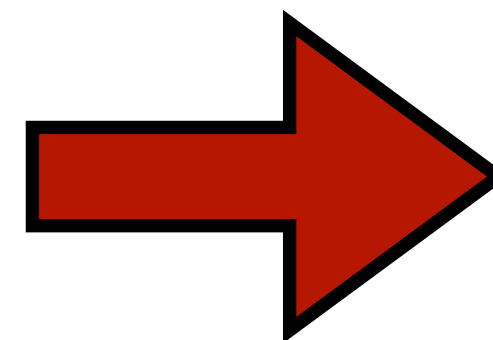

$$m_X \gtrsim \text{few GeV}$$

B. W. Lee and S. Weinberg, Phys. Rev. Lett. 39, 165 (1977)

E.W. Kolb and K. Olive, Phys.Rev. **D34** (1986) 2531

Way out: have **new light boson** that mediates the interaction → “hidden sector”

Boehm and Fayet [hep-ph/0305261]

Pospelov et al [0711.4866]

challenges for meV-GeV DM direct detection

fundamental challenge:

need enough **energy transfer**
from DM-target interaction
to create a detectable **signal**



*depends on process
and
detector setup*

detecting sub-GeV DM in 2 easy steps

1. decrease energy threshold or sensitivity

consider a variety of materials

2. increase the energy transfer

consider different physical processes

sub-GeV DM direct detection

- **Dark matter-electron scattering** in noble liquids, semiconductors, and organic molecules
- **Dark matter-nuclear scattering** through the Migdal scattering and bremsstrahlung
- **Absorption** of light dark matter, including axion-like particles and dark photons.
- **Dark matter scattering off collective modes** in molecules and in crystals (including phonons, plasmons and magnons)

Nuclear vs. Electron Scattering

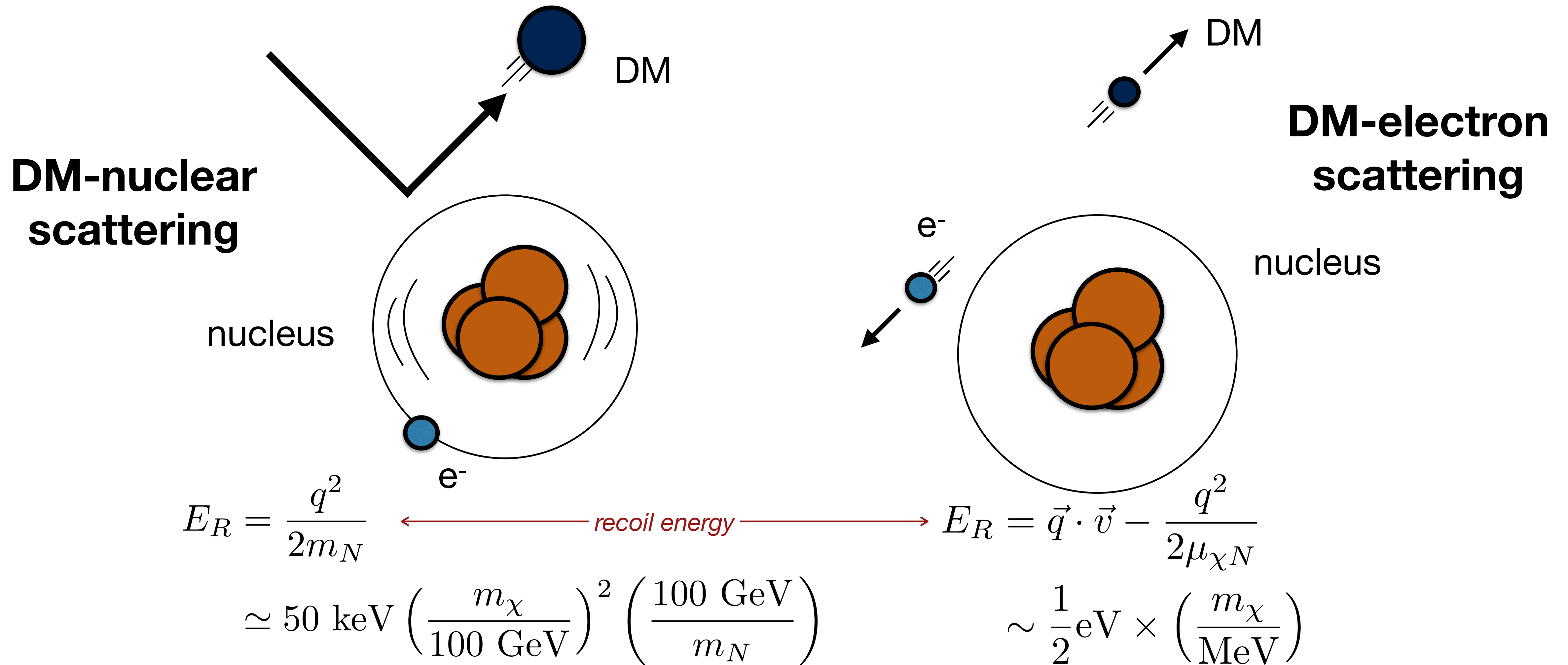

DM-electron scattering rate

particle physics

$$\frac{d\langle\sigma v\rangle}{d\ln E_R} = \frac{\bar{\sigma}_e}{8\mu_{\chi e}^2} \int q dq |f(k, q)|^2 |F_{DM}(q)|^2 \eta(v_{min})$$

$$\bar{\sigma}_e = \frac{\mu_{\chi e}^2}{16\pi m_\chi^2 m_e^2} \overline{|\mathcal{M}_{\chi e}(q)|^2}_{q^2=\alpha^2 m_e^2}$$

$$F_{DM}(q) \simeq \begin{cases} 1 & \text{heavy mediator} \\ \frac{\alpha m_e}{q} & \text{electric dipole moment} \\ \frac{\alpha^2 m_e^2}{q^2} & \text{light mediator} \end{cases}$$

DM-electron limits in 2018

Essig, Volansky, TTY Phys.Rev.D 96 (2017) 4, 043017 [1703.00910]

DarkSide Collaboration Phys.Rev.Lett. 121 (2018) 11, 111303 [1802.06998]

An, Pospelov, Pradler, Ritz Phys.Rev.Lett. 120 (2018) 14, 141801 [1708.03642]

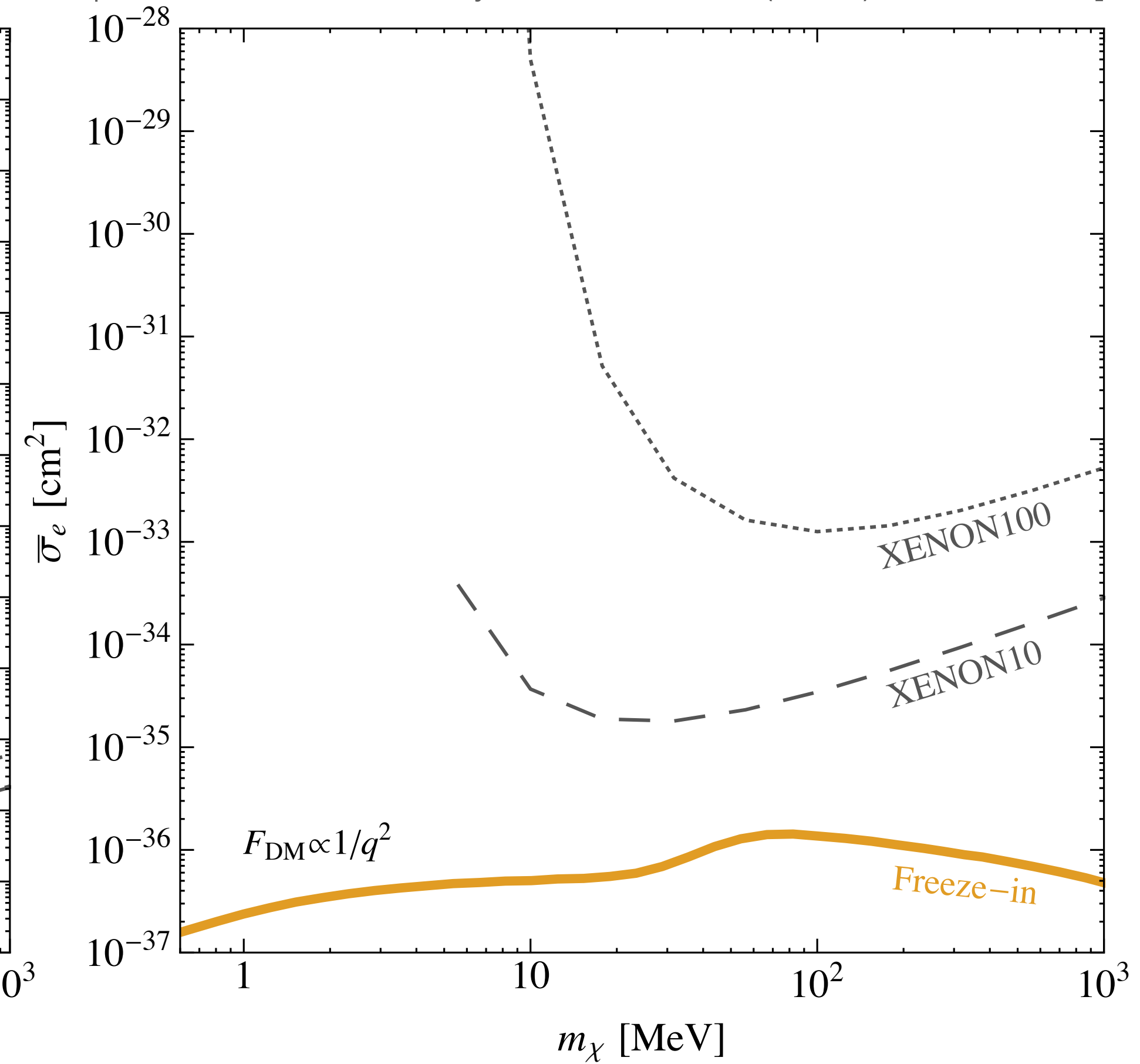
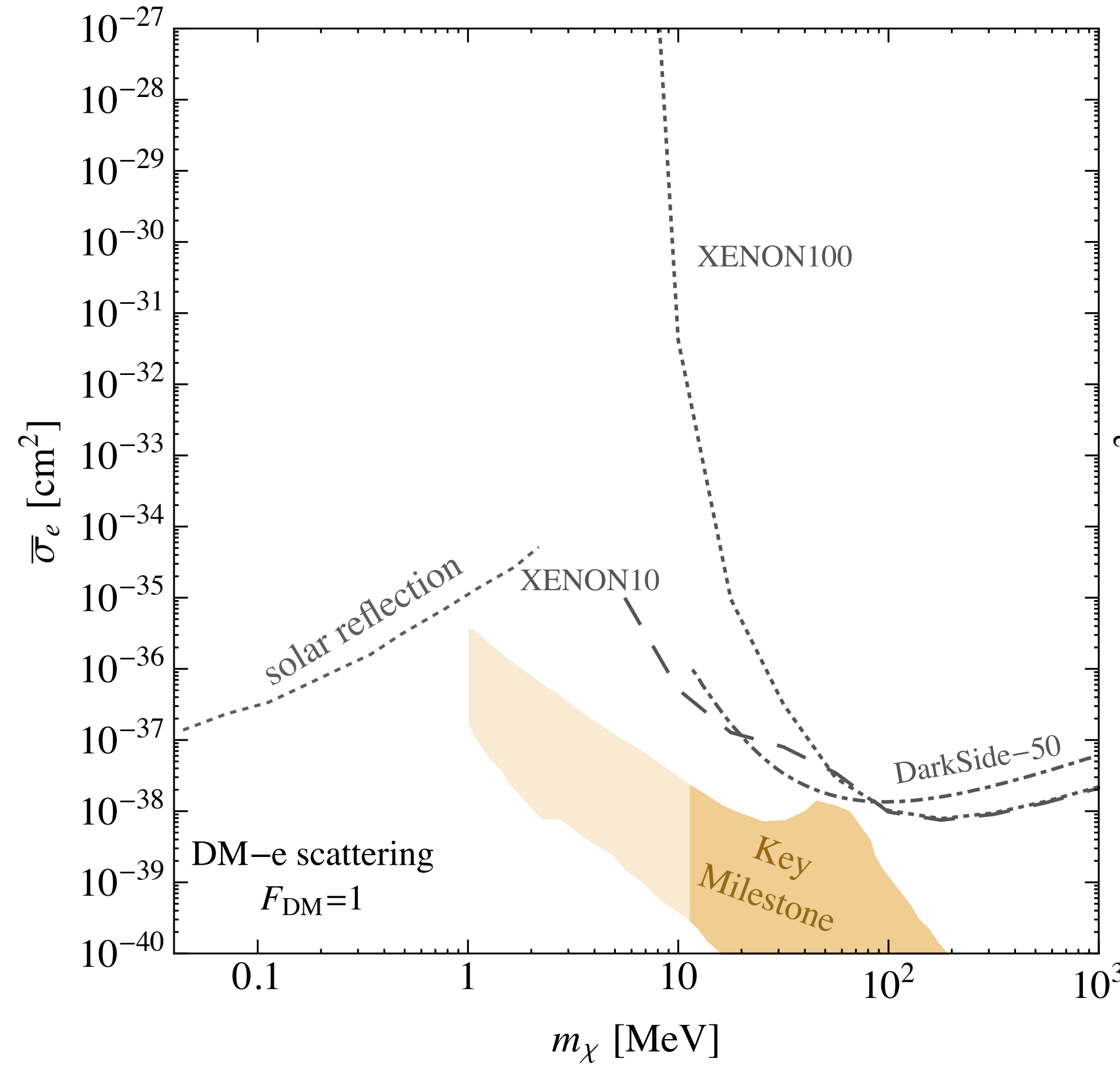

a brief history

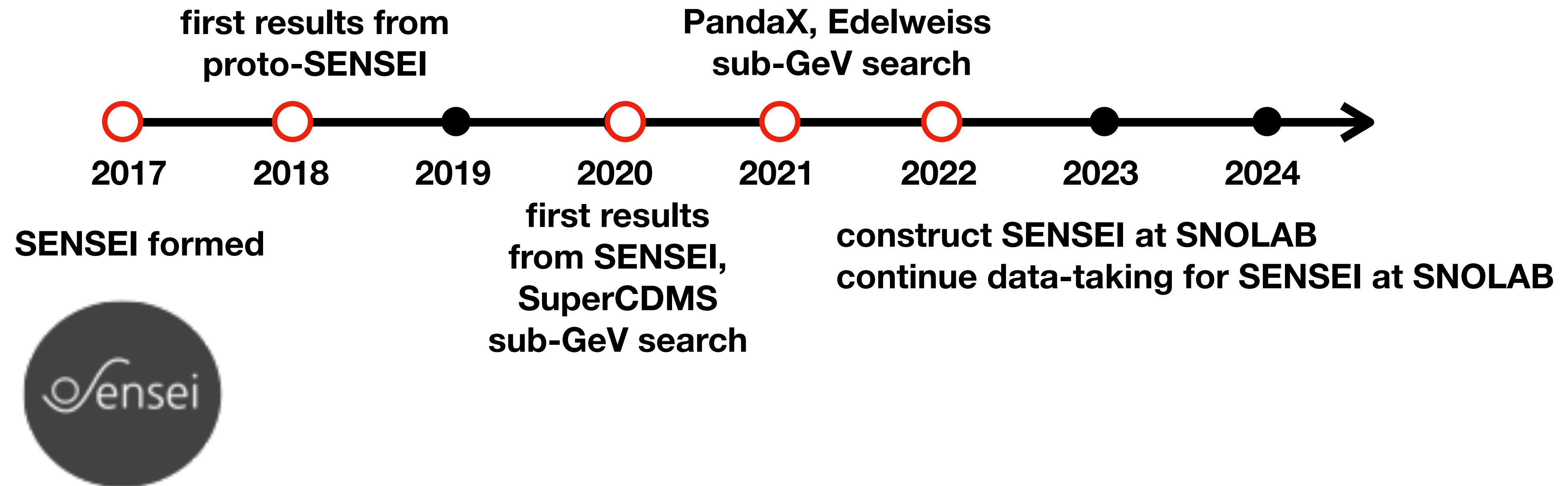

DM-electron scattering limits in 2022

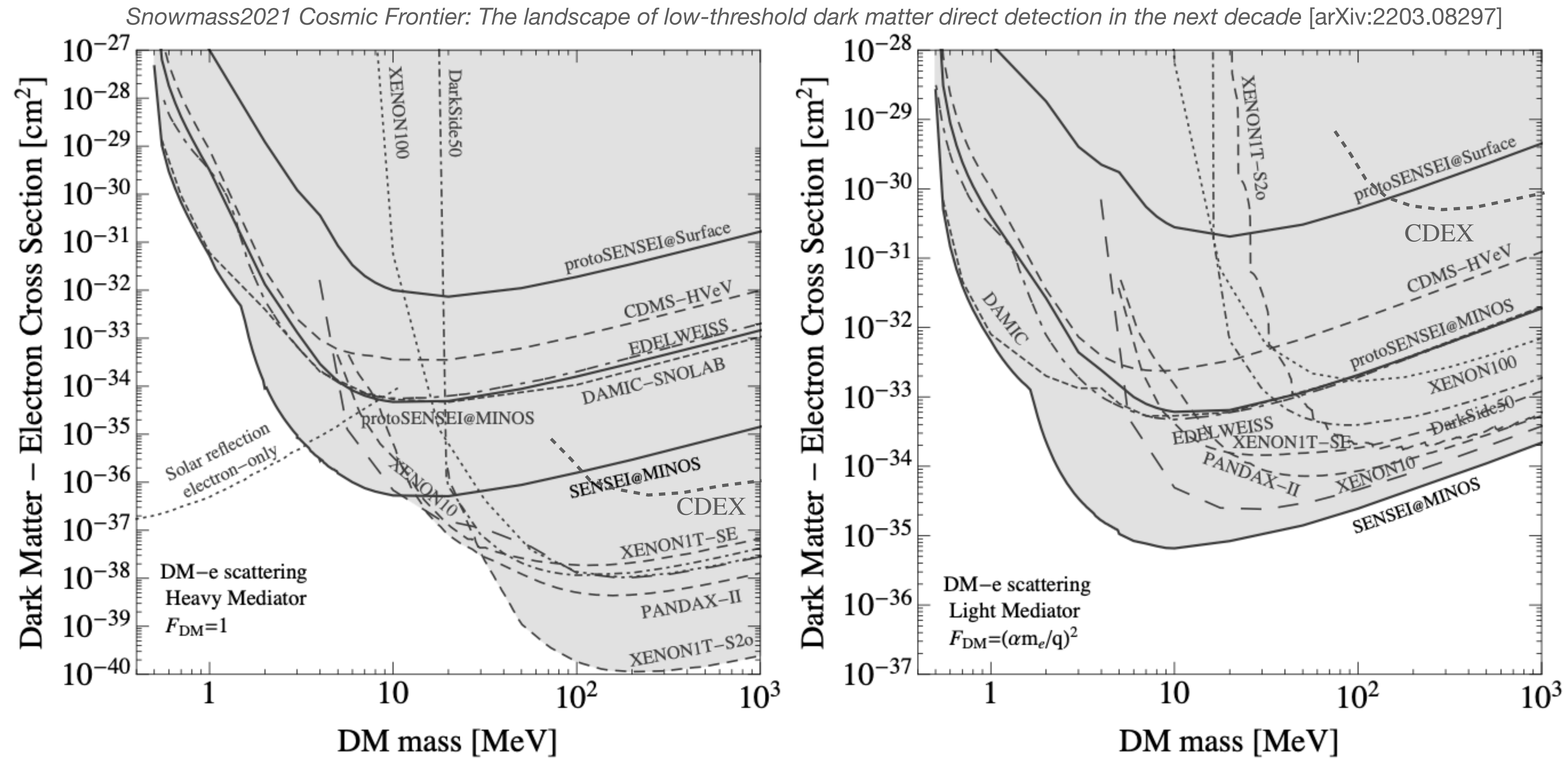

+CDEX
 [arXiv:2206.04128]

looking forward

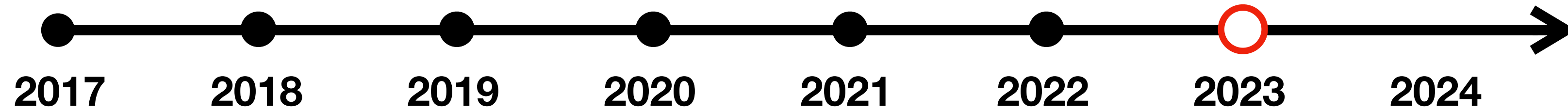

- construct SENSEI at SNOLAB
- continue data-taking for SENSEI at SNOLAB
- **final analysis of 100-gram SENSEI data**
- **launch of 1-kg DAMIC-M at Modane**
- **complete R&D for Oscura**

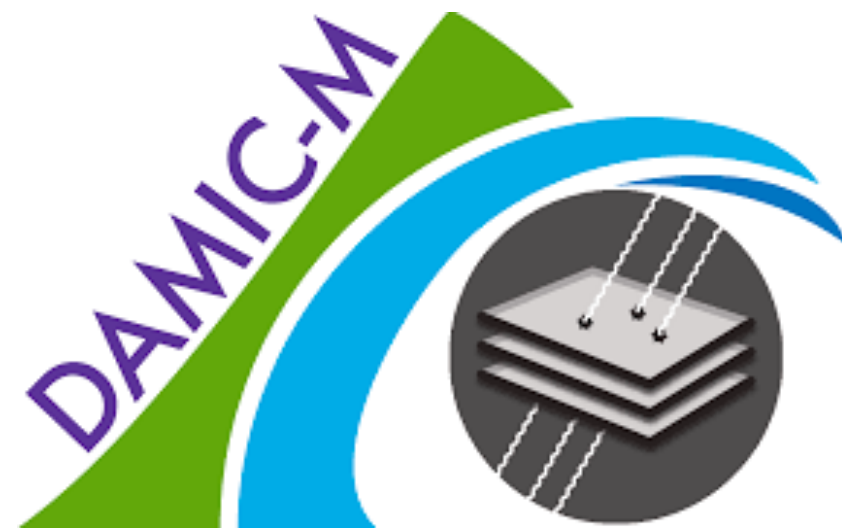

Oscura

Snowmass2021 - Letter of Interest

Status and plans for Oscura: A Multi-kilogram Skipper-CCD Array for Direct-Detection of Dark Matter.

Thematic Areas:

- (CF1) Cosmic Frontier: Dark Matter: Particle Like
- (IF2) Instrumentation Frontier: Photon Detectors

Contact Information:

Juan Estrada (Fermilab)

Authors: Daniel Baxter (U. Chicago), Itay Bloch (Tel-Aviv), Mariano Cababie (U. Buenos Aires), Nuria Castello (Inst. de Física de Cantabria), Luke Chaplinsky (UMass Amherst), Alvaro Chavarria (U. Washington), Juan Carlos D'Olivo (UNAM), Rouven Essig (Stony Brook), Juan Estrada (FNAL), Erez Etzion (Tel-Aviv), Guillermo Fernandez-Moroni (Fermilab), Stephen Holland (LBNL), Todd W. Hossbach (PNNL), Ben Kilminster (U. Zurich), Ian Lawson (SNOLAB), Steven J. Lee (U. Zurich), Ben Loer (PNNL), Pitam Mitra (U. Washington), Jorge Molina (U. Asuncion), Danielle Norcini (U. Chicago), Paolo Privitera (U. Chicago), Karthik Ramanathan (U. Chicago), Dario Rodrigues (U. Buenos Aires), Richard Saldanha (PNNL), Radomir Smida (U. Chicago), Miguel Sofo-Haro (CNEA), Javier Tiffenberg (Fermilab), Sho Uemura (Tel-Aviv), Ivan Vila (Inst. de Física de Cantabria), Rocio Vilar (Inst. de Física de Cantabria), Tomer Volansky (Tel-Aviv), Tien-Tien Yu (Oregon),

Abstract: Recent advances in silicon skipper-CCDs have demonstrated this technology as a powerful probe for sub-GeV dark matter by enabling ultra-sensitive searches for electron recoils from dark matter-electron interactions. World-leading results have already been produced by the SENSEI collaboration using a single skipper-CCD with an active mass of ~ 2 gram. Pathfinder experiments using skipper-CCDs are planned for the coming years, with SENSEI-100 (~ 100 g detector) and DAMIC-M (~ 1 kg detector) expected to start operations during 2020 and 2023, respectively. We are preparing a white paper describing the status and plans of the Oscura R&D effort to develop a ~ 10 -kg skipper-CCD experiment for dark matter.

**Brings together
Si CCD
community**

looking forward

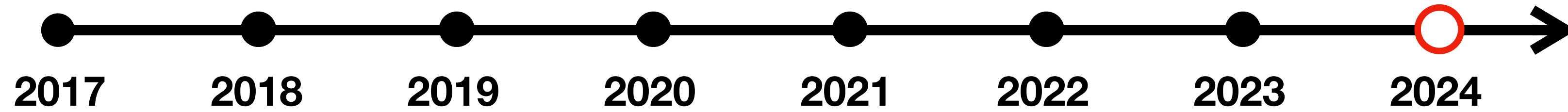

- construct SENSEI at SNOLAB
- continue data-taking for SENSEI at SNOLAB
- final analysis of 100-gram SENSEI data
- launch of 1-kg DAMIC-M at Modane
- complete R&D for Oscura
- **launch of 10-kg Oscura**

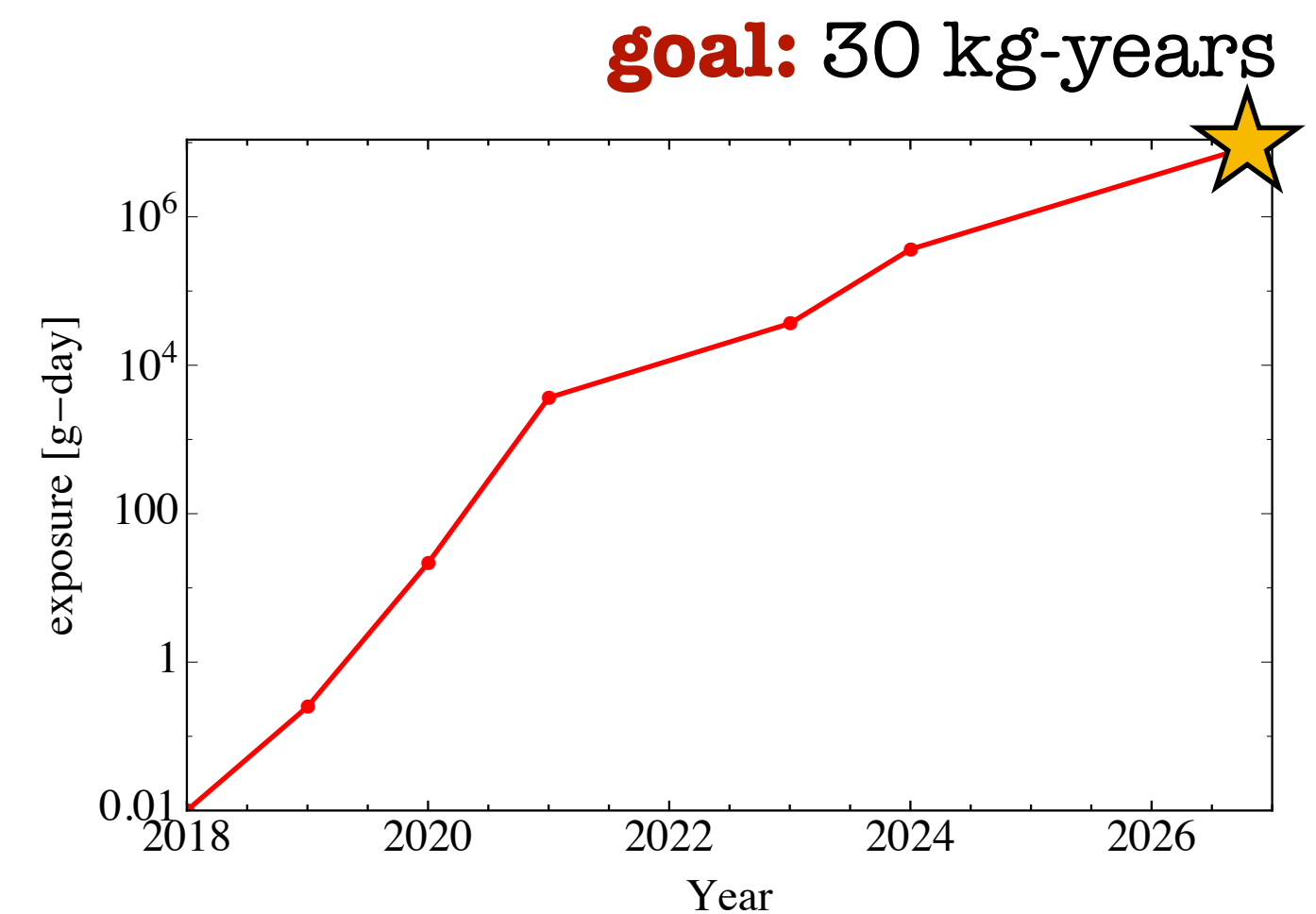

Looking forward

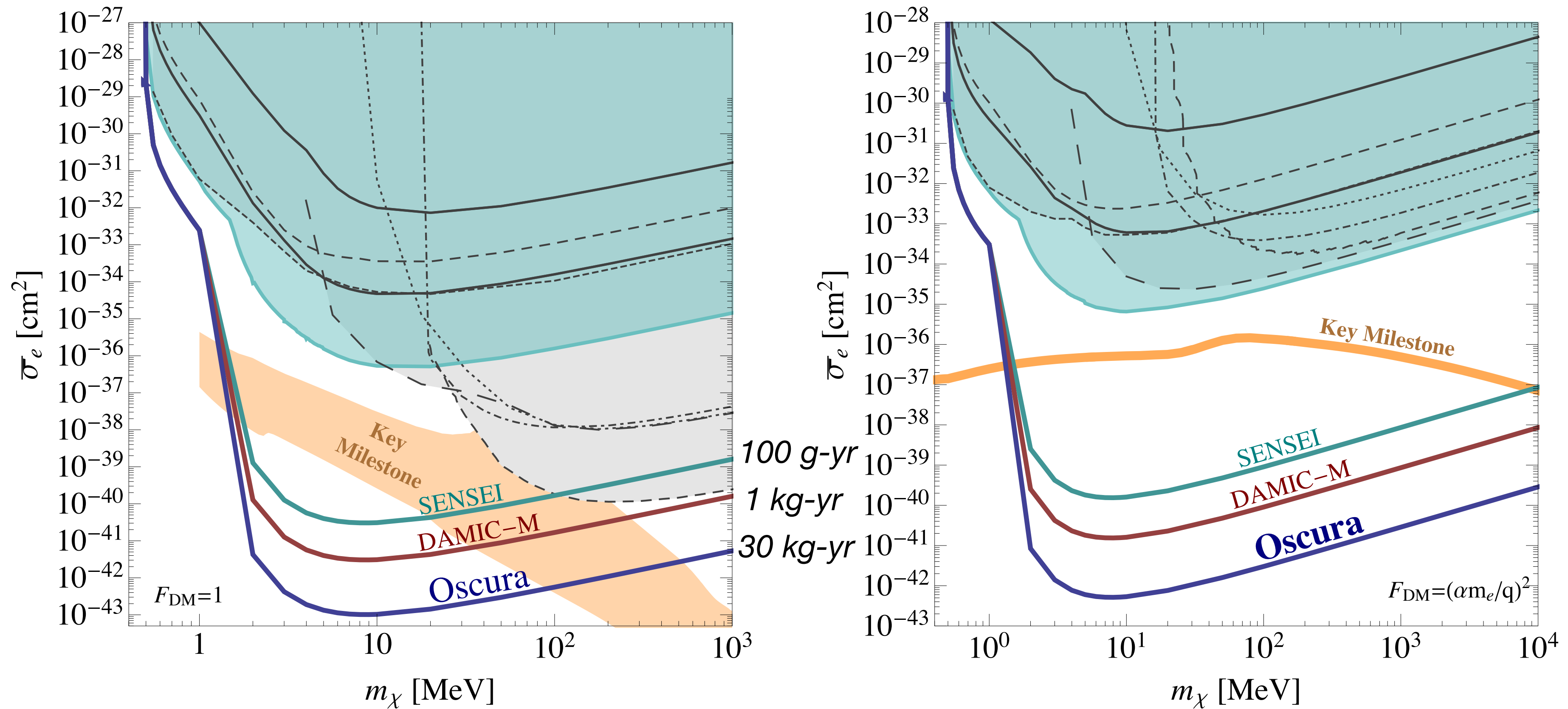

Projections for future Si Skipper-CCD experiments

Dark Matter Candidates

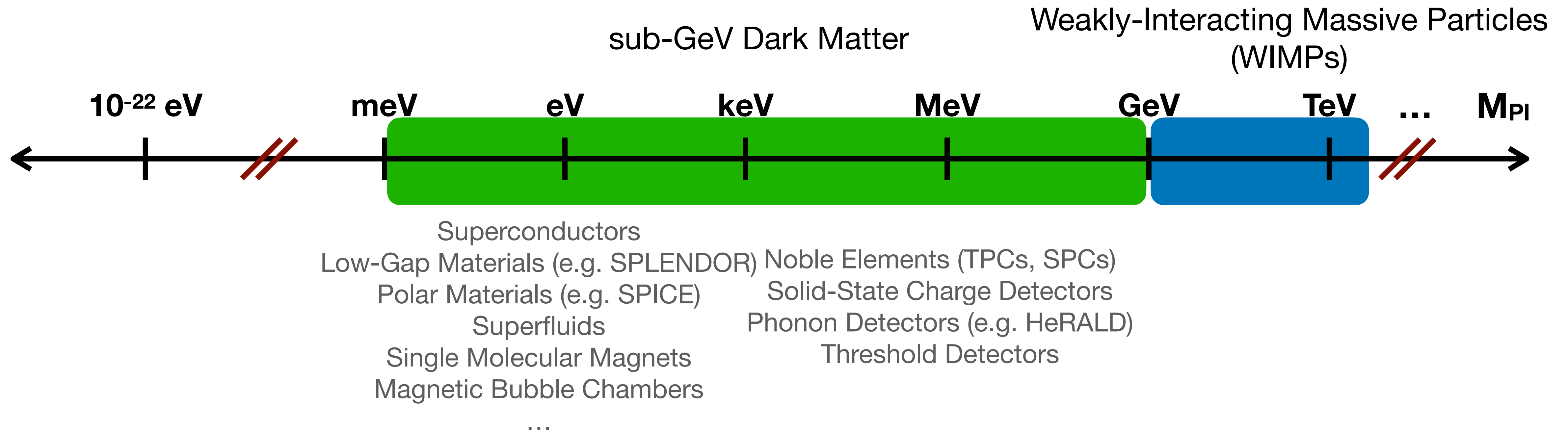

Outlook for sub-GeV DM direct detection

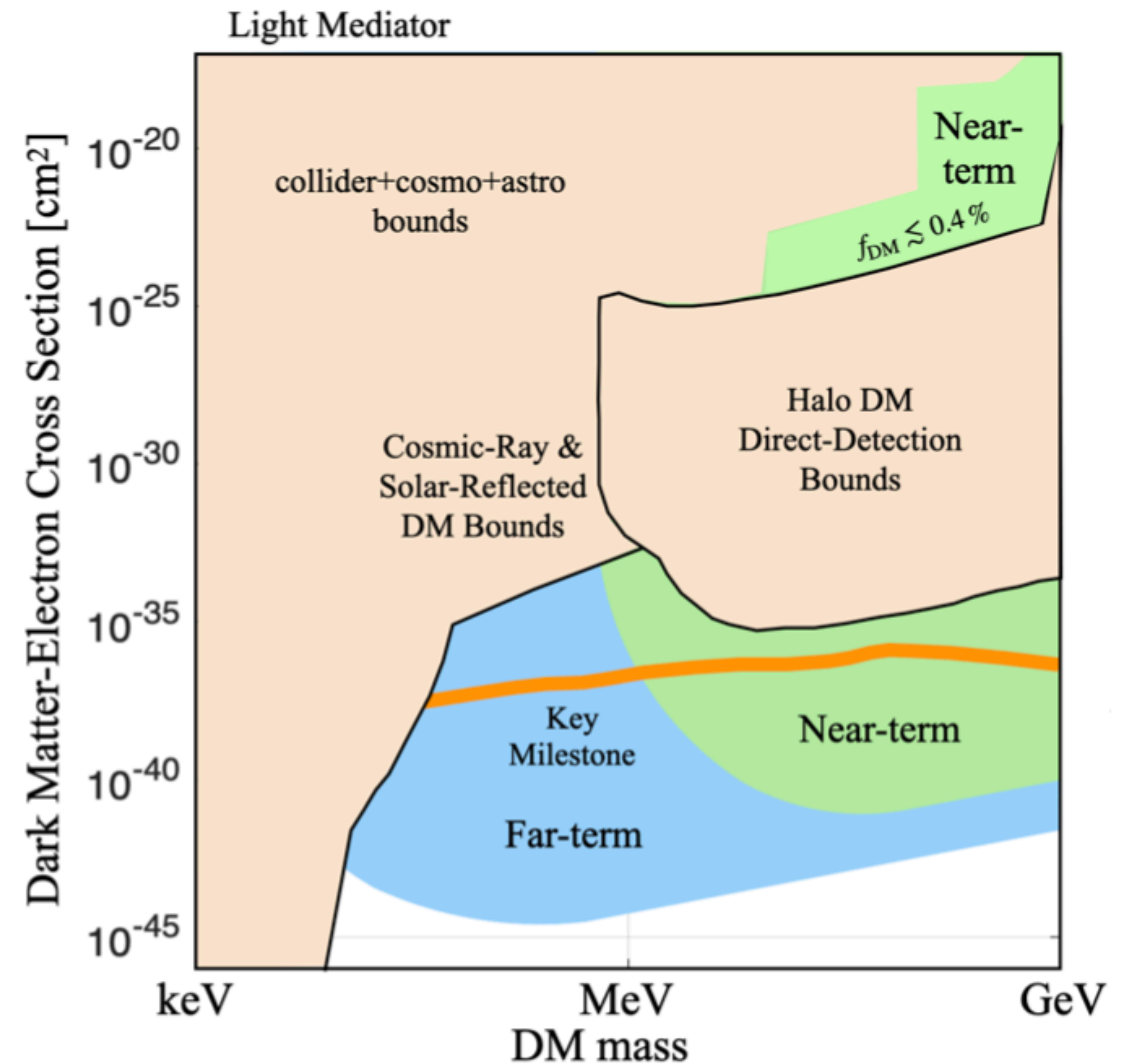
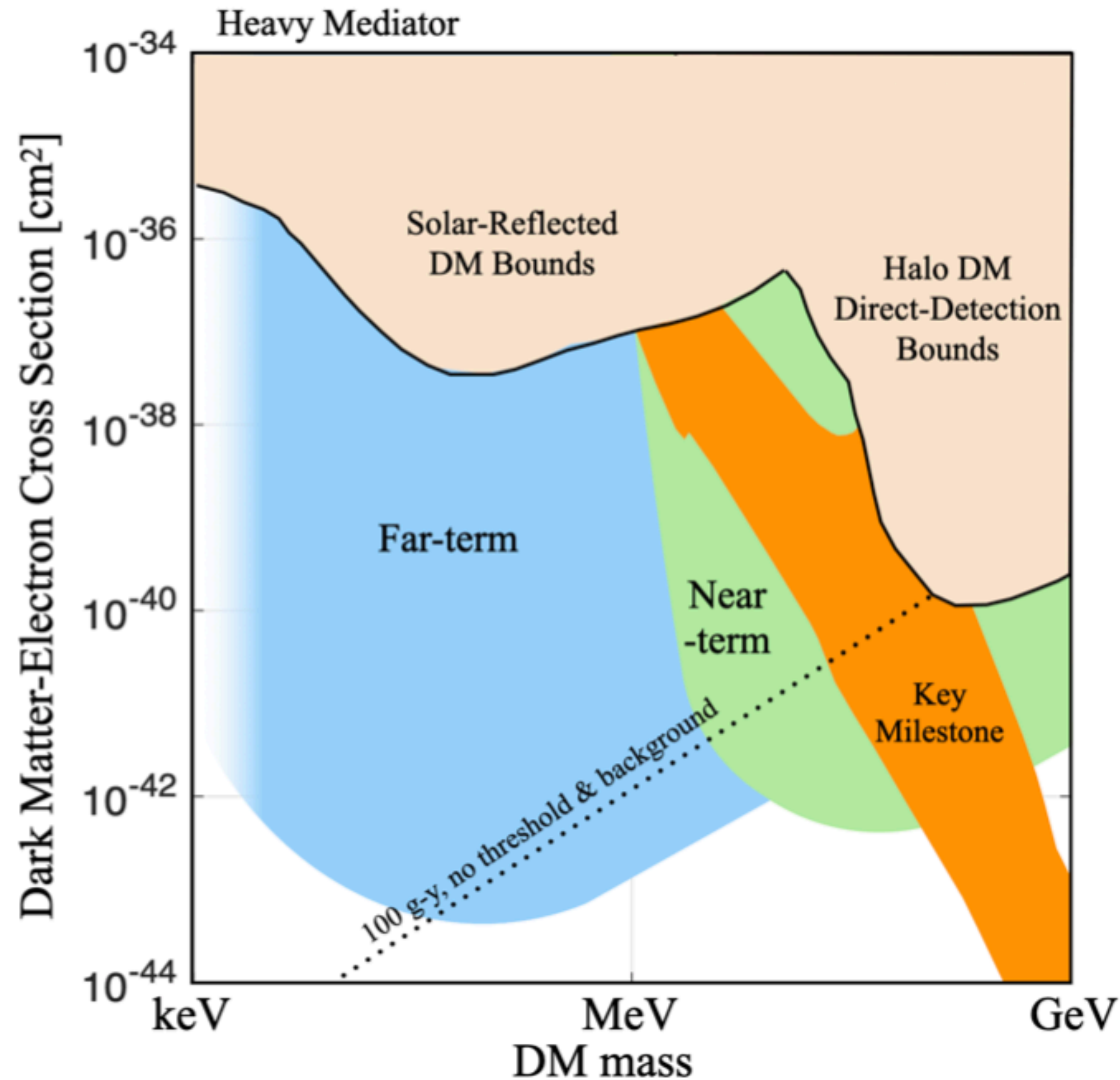

Snowmass2021 Cosmic Frontier: The landscape of low-threshold dark matter direct detection in the next decade [arXiv:2203.08297]

sub-GeV DM direct detection

- **Dark matter-electron scattering** in noble liquids, semiconductors, and organic molecules
- **Dark matter-nuclear scattering** through the Migdal scattering and bremsstrahlung
- **Absorption** of light dark matter, including axion-like particles and dark photons.
- **Dark matter scattering off collective modes** in molecules and in crystals (including phonons, plasmons and magnons)

models for sub-GeV DM

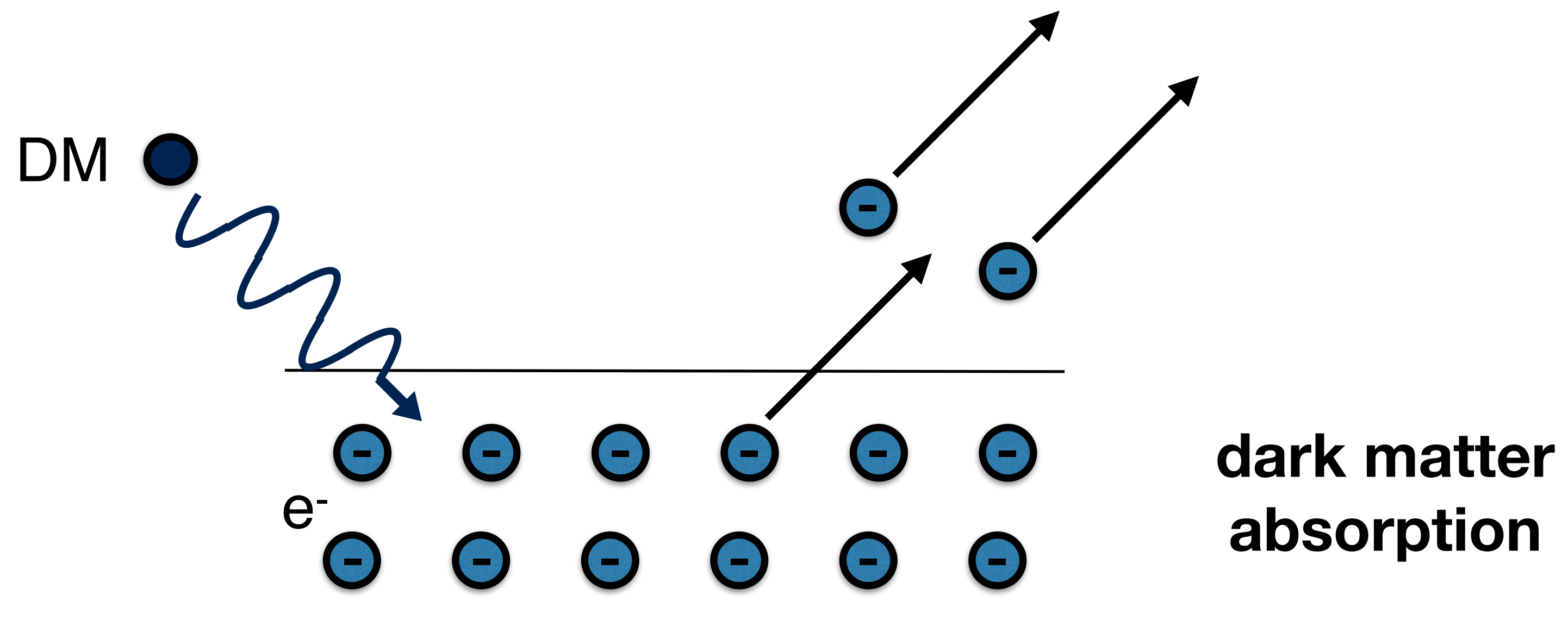
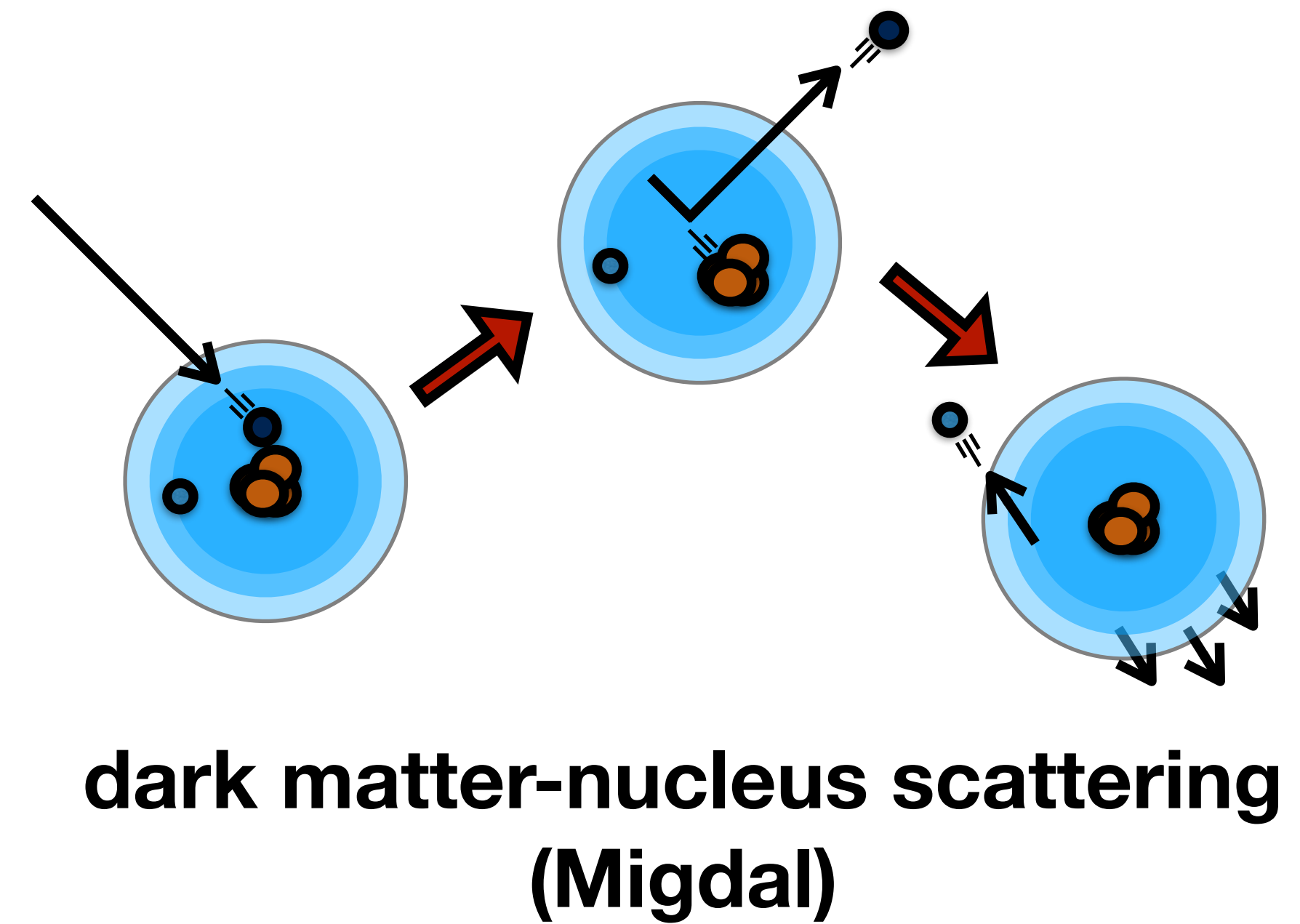
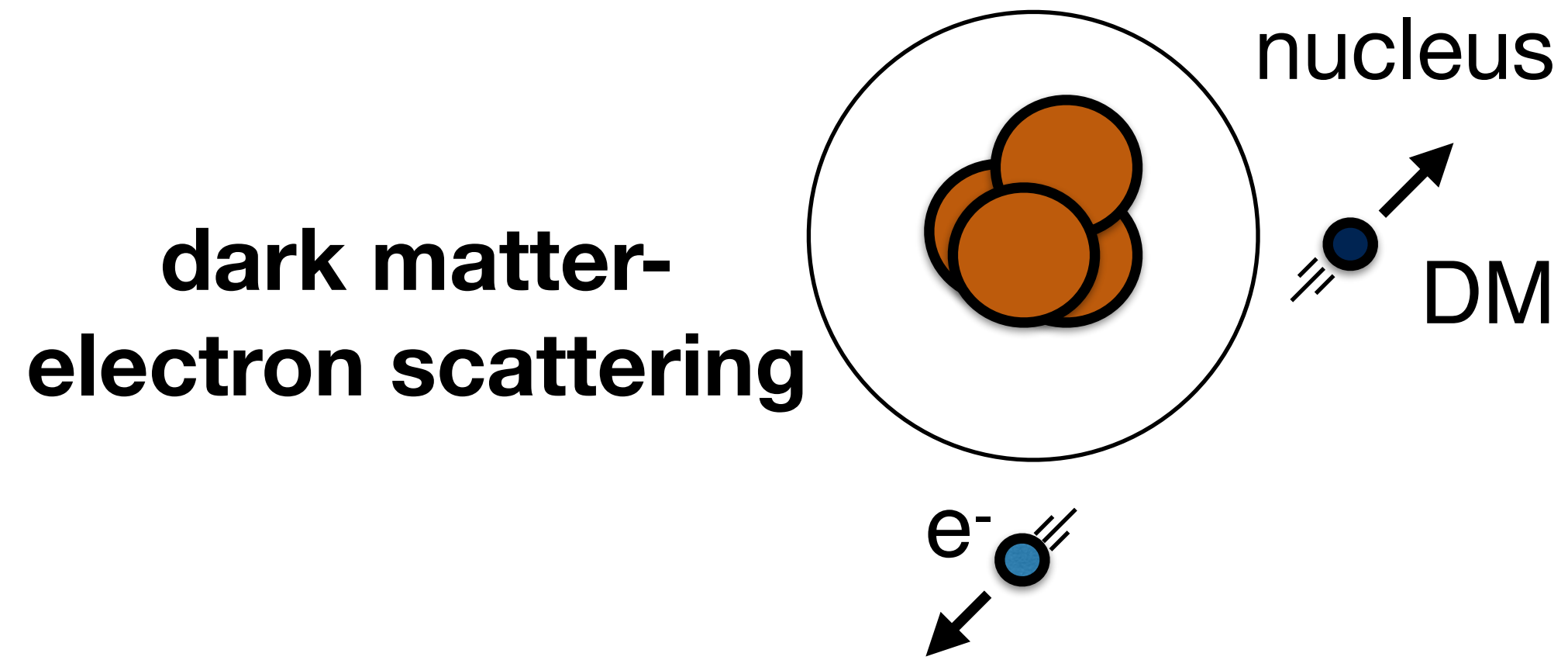

Other Models

DM-nucleon scattering

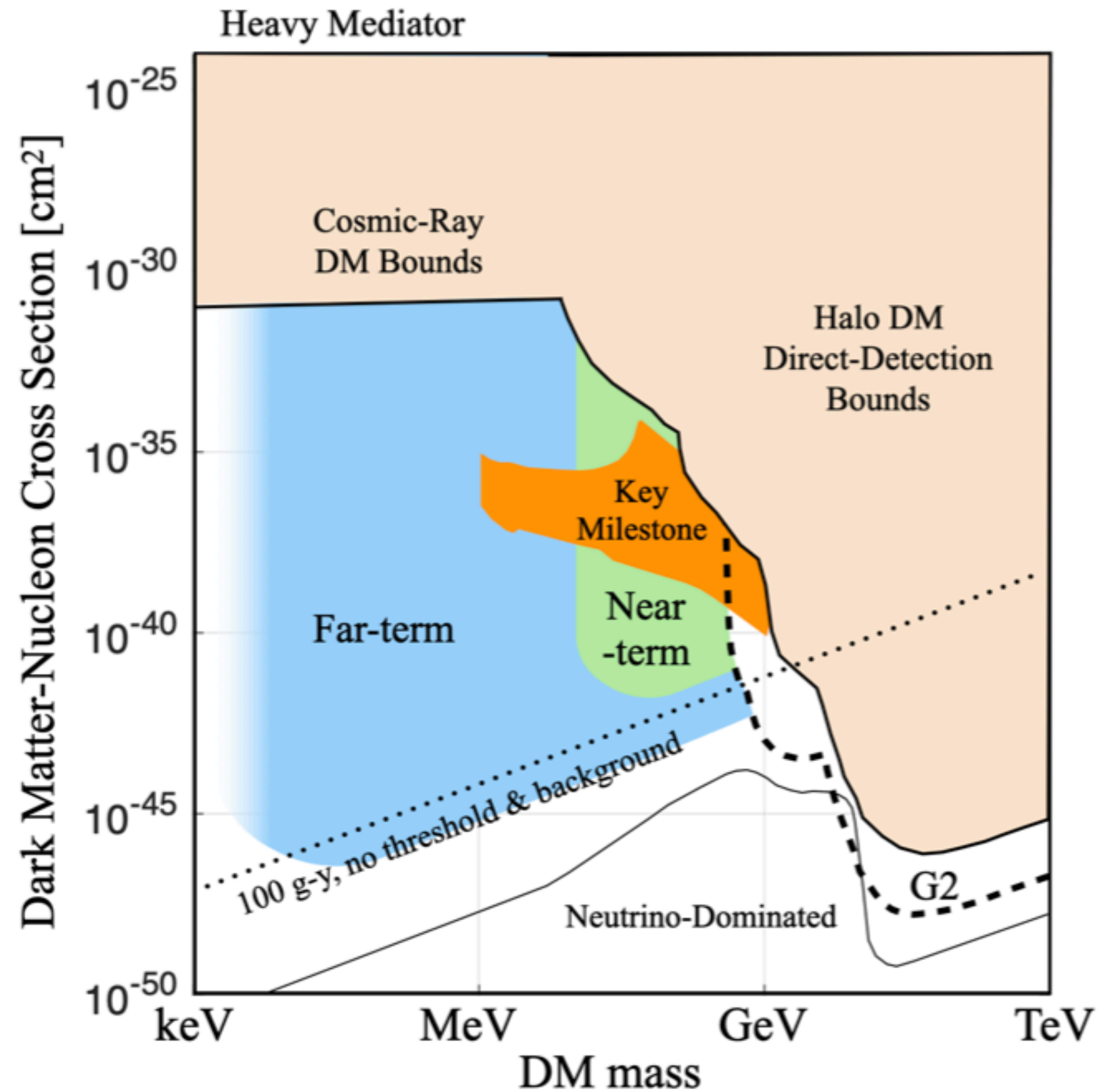

DM absorption

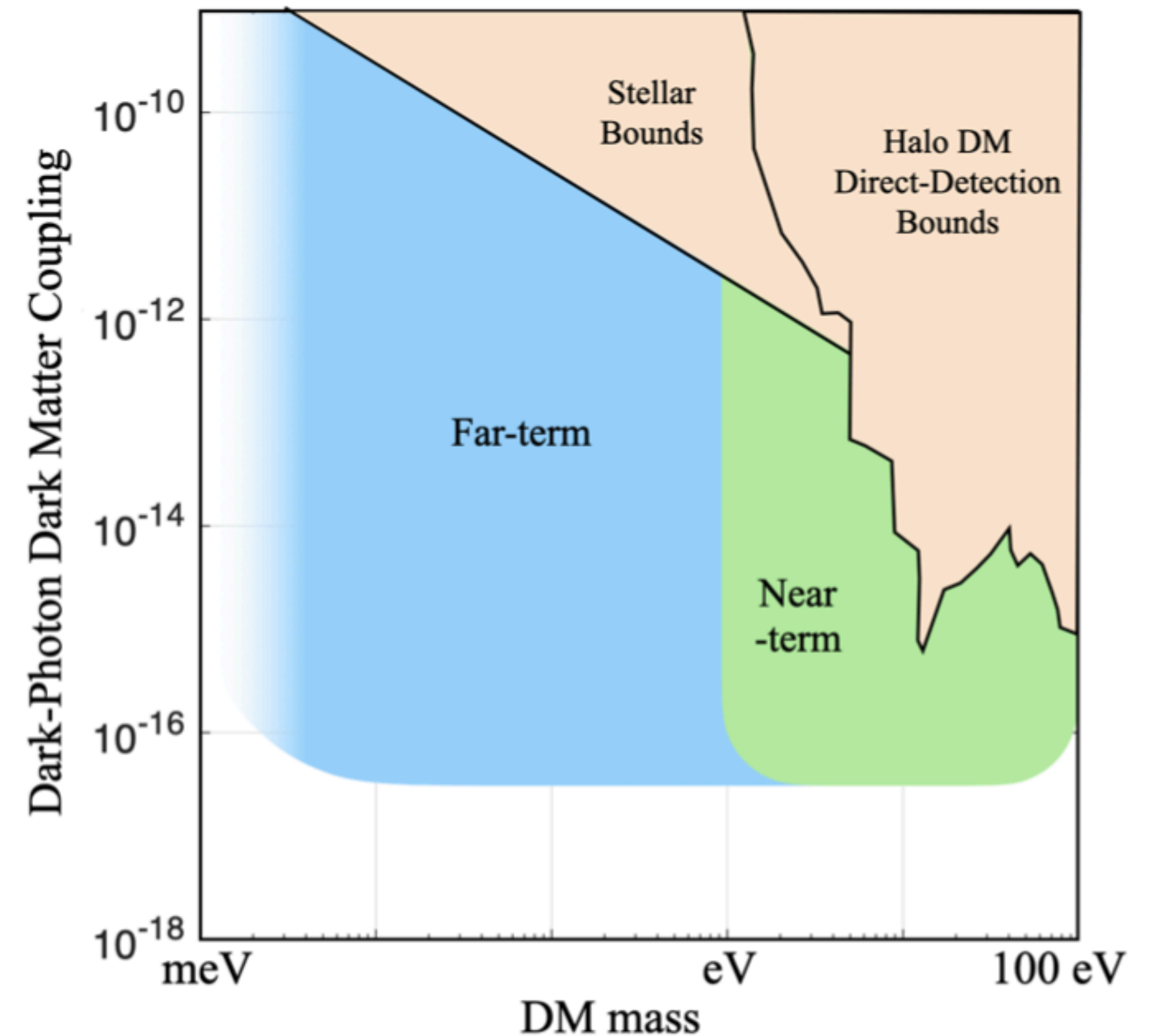

Snowmass2021 Cosmic Frontier: The landscape of low-threshold dark matter direct detection in the next decade [arXiv:2203.08297]

sub-GeV DM direct detection

- **Dark matter-electron scattering** in noble liquids, semiconductors, and organic molecules
- **Dark matter-nuclear scattering** through the Migdal scattering and bremsstrahlung
- **Absorption** of light dark matter, including axion-like particles and dark photons.
- **Dark matter scattering off collective modes** in molecules and in crystals (including phonons, plasmons and magnons)

TESSERACT project (part of the DMNI suite of DOE-supported efforts)

- Managed by LBNL
- Funding for R&D and project development began in June 2020.
- One experimental design, and different target materials with complementary DM sensitivity. Zero E-field.
- All using TES readout
- ~40 people from 8 institutes
- Includes SPICE (polar crystals) and HeRALD (superfluid helium). These are historical names, now shorthand for the targets.

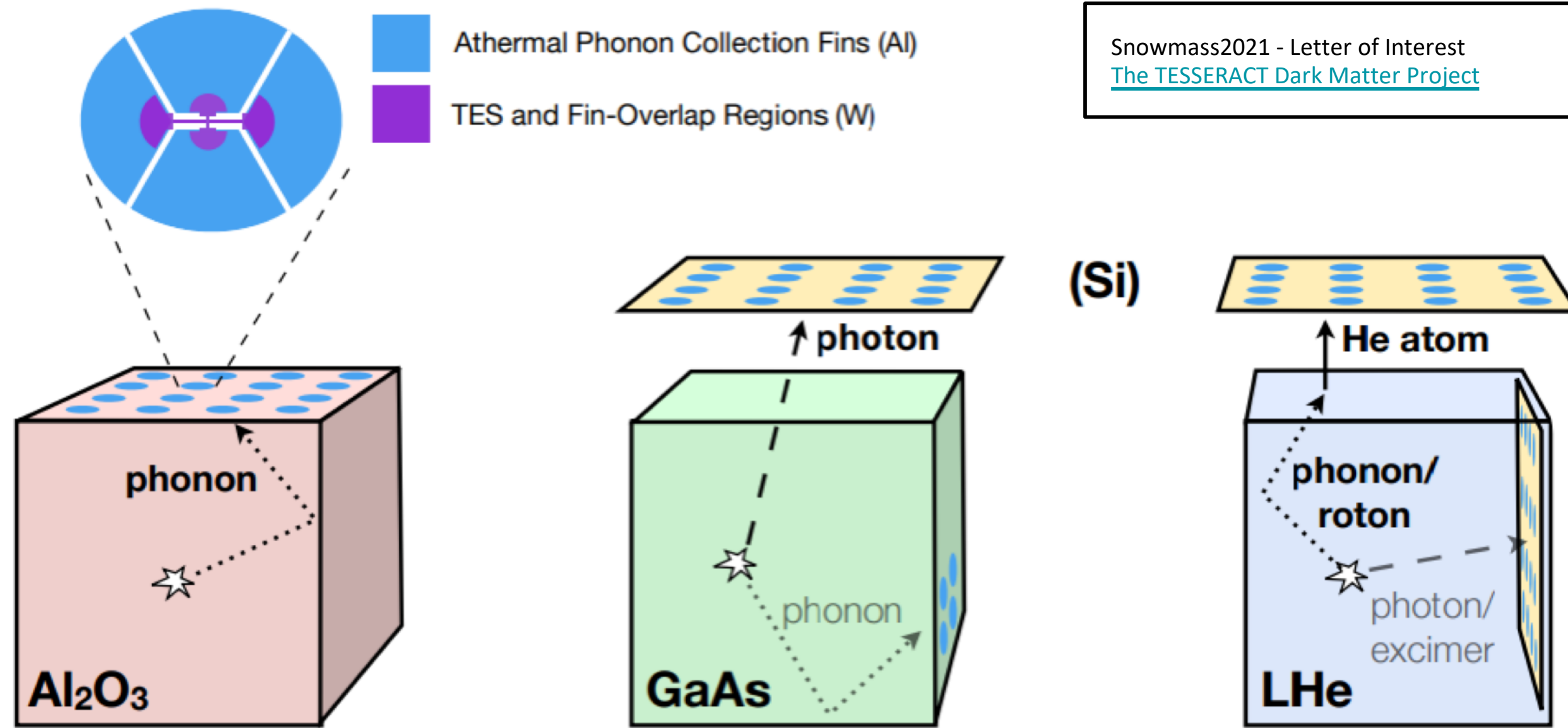

Snowmass2021 - Letter of Interest
[The TESSERACT Dark Matter Project](#)



Berkeley
UNIVERSITY OF CALIFORNIA



Caltech



FLORIDA STATE



TEXAS A&M
UNIVERSITY



Argonne
NATIONAL LABORATORY

UMass
Amherst



1

SPICE and HeRALD - projected sensitivity

Snowmass2021 - Letter of Interest
[The TESSERACT Dark Matter Project](#)

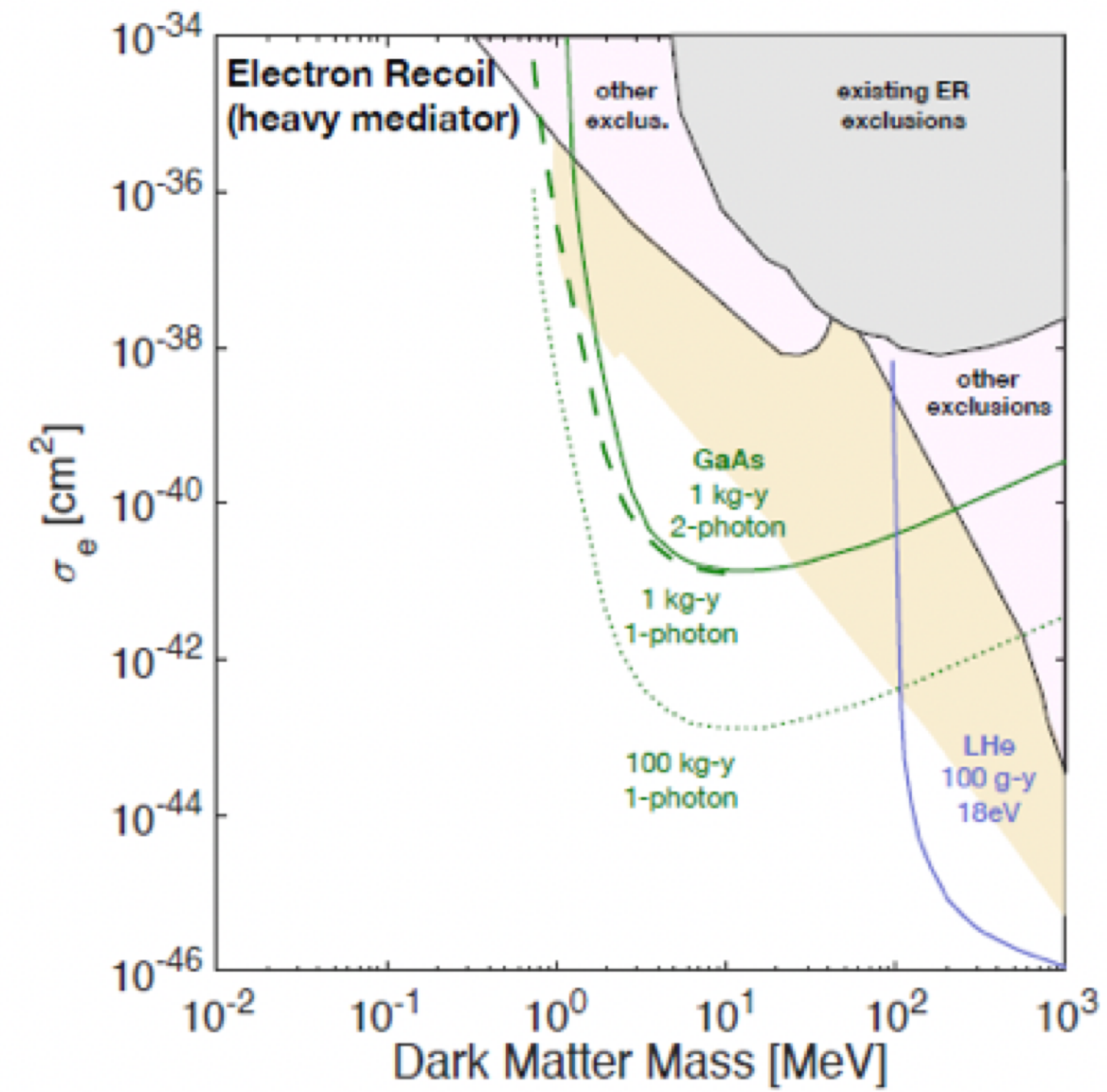
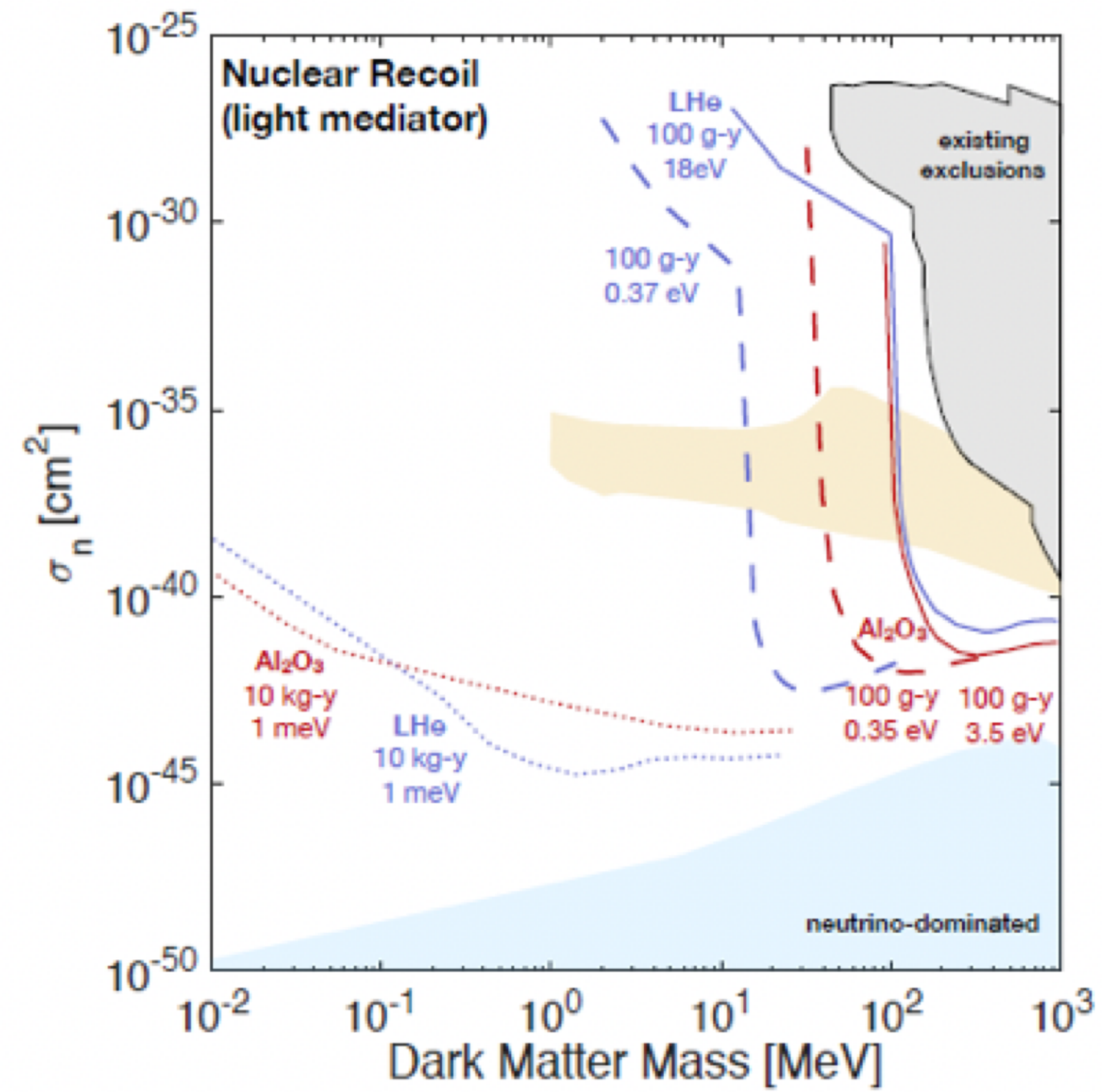

11

theoretical work

- formulation of DM-electron scattering rates using dielectric function
 - accounts for in-medium screening effects
 - data-driven form-factors

Knapen, Kozaczuk, Lin *Phys. Rev. D* 104, 015031 (2021)

Hochberg, Kahn, Kurinsky, Lehmann, Yu, Berggren *Phys.Rev.Lett.* 127 (2021) 15, 151802

- Using semi-analytic approximations to include higher momentum components and energy states Griffin, Inzani, Trickle, Zhang, Zurek [arXiv:2105.05253]
- Analytic formalism for single-phonon to multi-phonon processes to nuclear recoil Campbell-Deem, Knapen, Lin, Villarama [arXiv:2205.02250]

Dark Matter Candidates

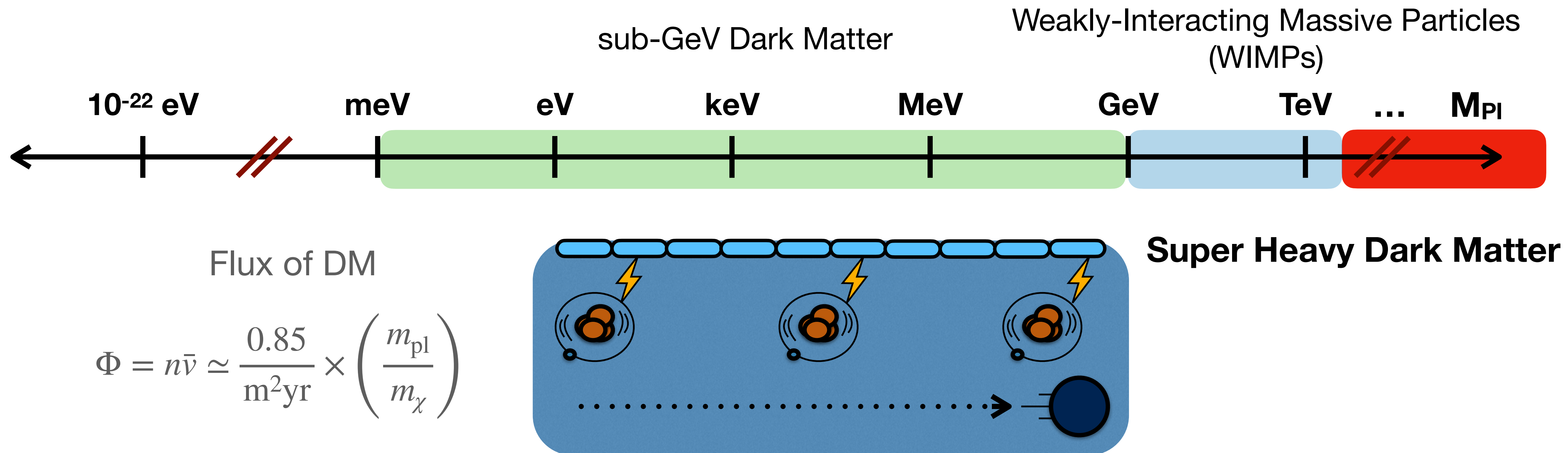

Super-Heavy Dark Matter

[arXiv:2209.07426]

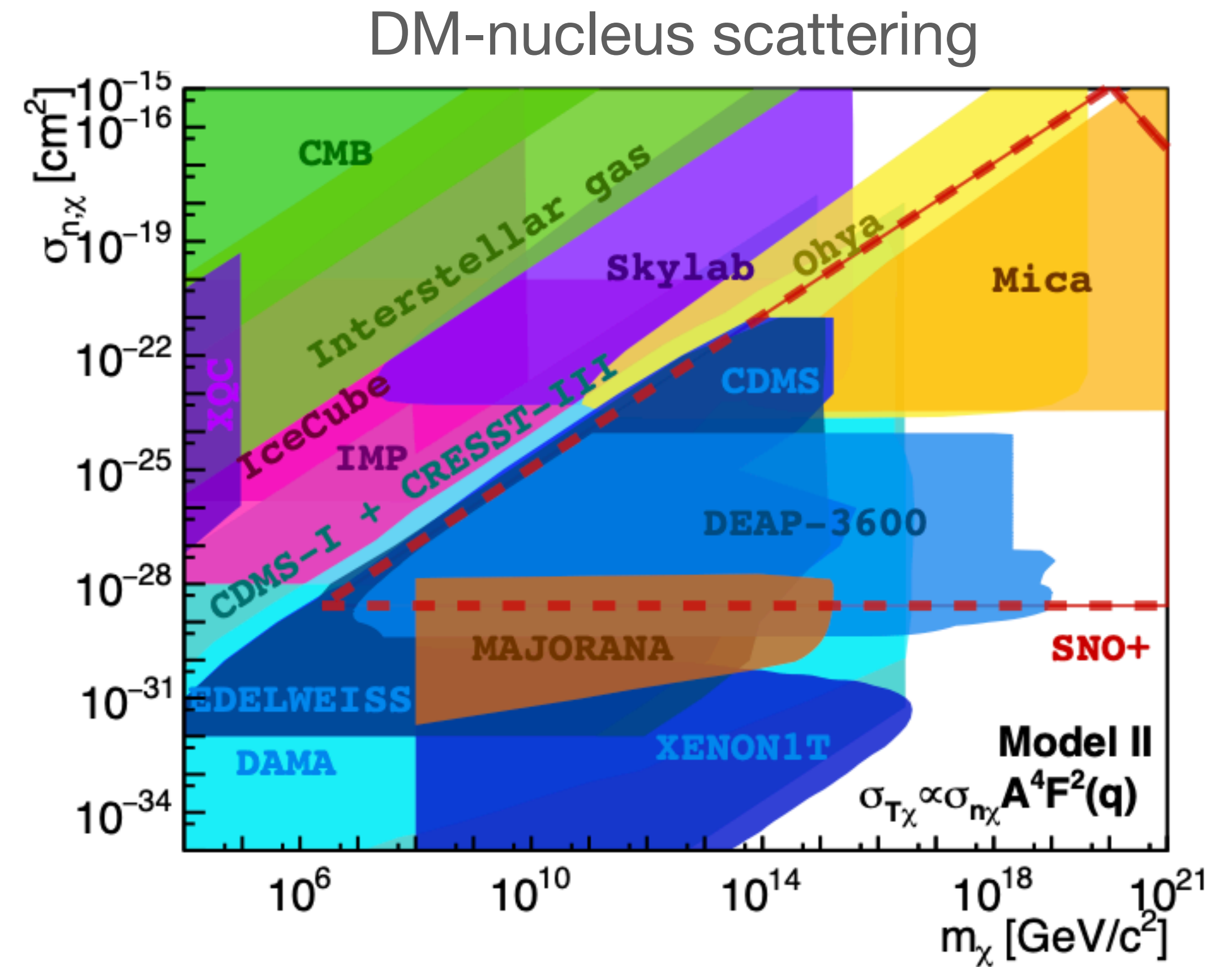
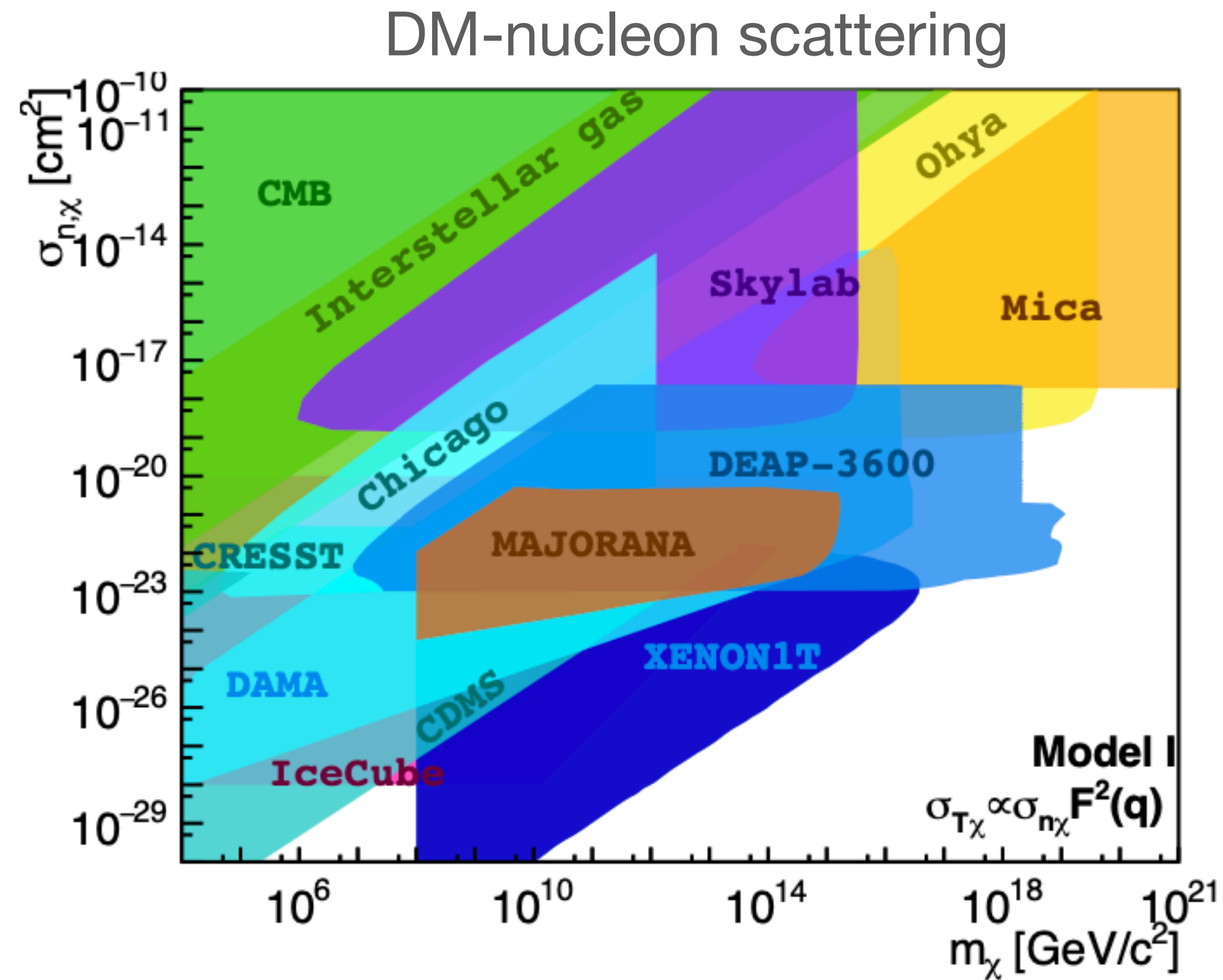

many of the **same** DM experiments!

Summary

- There are a wide range of motivated DM candidates spanning many orders of magnitude in mass space
- Direct detection is necessary to understand particle nature of DM as it probes cosmological abundance, stability, interactions with the SM
- Several new and upgraded experiments coming online in the next several years
- These include new technologies and techniques
- These experiments are sensitive to a wide range of DM models and more!
- complementary to accelerator experiments, cosmology, and indirect detection