



# Magnet Power Supply Development for HEPS

**Bin Chen** ( IHEP, CAS )

**IAS Program on High Energy Physics 2023, Hong Kong**



# Content

---

- **Introduction**
- **Design scheme**
- **Design and development**
- **Summary**

# Introduction

## ■ Overview of HEPS

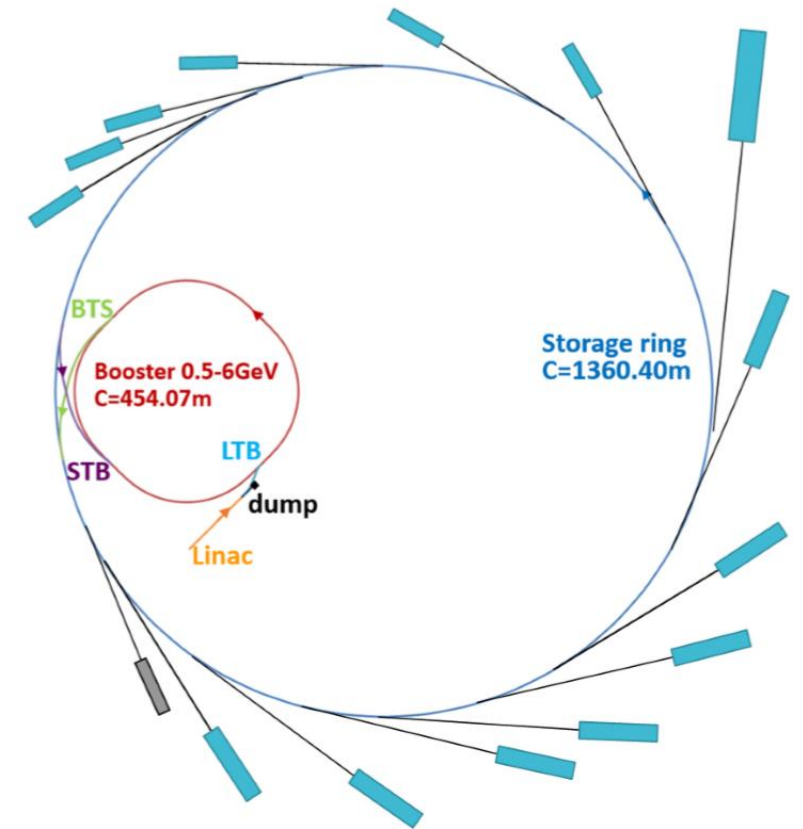

■ High Energy Photo Source (HEPS) is the fourth generation of Synchrotron radiation source.

✓ Energy: 6GeV

✓ Emittance: 60 pm rad (ultra-low)

# Introduction

## ■ Overview of Magnet Power Supply in HEPS

- HEPS requires more than 2400 power supplies with either unipolar or bipolar DC output currents, and about 100 power supplies with 1Hz dynamic current output.
  - ✓ **BLG: longitudinal gradient dipole, based on permanent magnets, no PS needed**
- The power supply performance requirements are much more stringent.
  - ✓ **The output current stability of main power supply in storage ring is required to be better than 10ppm.**
  - ✓ **The bipolar power supplies for the fast correction magnets are required to have a wide bandwidth of 10kHz.**

Parameter	Power Supply						
	BD	Quad.	Sex.	Oct.	Normal Corrector	Fast Corrector	
absolute accuracy (ppm, referred to $I_{max}$ )	100	100	100	100	100	100	
stability(ppm, referred to $I_{max}$ )	<300 ms	10	10	20	20	25	25
	<10sec	10	10	20	20	50	50
	<8h	20	20	40	40	100	100
small signal BW (Hz)	-	-	-	-	-	10K	
reproducibility(ppm, referred to $I_{max}$ )	50	50	100	100	100	100	
current ripple(ppm, great than 50Hz, referred to $I_{max}$ )	TBD	TBD	TBD	TBD	TBD	TBD	

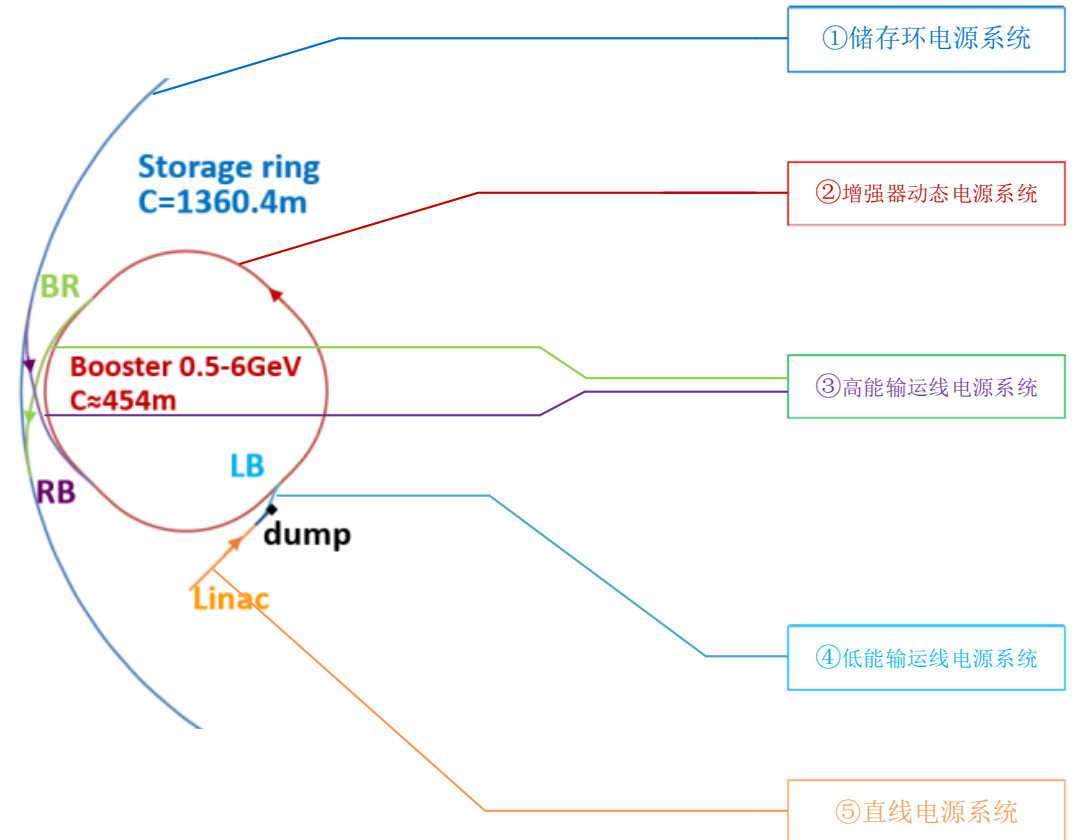

# Design scheme

## ■ Based on the requirements from physicists and magnet designers:

- mostly power supplies are with current around 200A;
  - ✓ powering optimization with magnet designers, e.g., decreasing the current for BD, and increasing the current for sextupole and octupole, and minor adjustments for quadrupole to promise the current level for each ps as close as possible;
- same power module with 200A; PS supplied individual magnet is based on single module; and PS supplied serial-connected magnets is based on multi-modules in series/parallel.
- all power supplies is based on switching-mode topology with high efficiency, reduced size and weight, easy interface to digital controller, and higher order voltage ripple components with less influence on magnet current.
- all are digital-controlled with self-designed Digital Power Supply Control Module (DPSCM).
- all power supplies is mounted self-designed DCCT (two scales, 300A DCCT for main magnet PS, and 20A DCCT for corrector PS).

# Design scheme

- **The digital control power supplies are split in three independent parts**
  - A power part acting as a voltage source or a current source, which is suitable for industrial design and production
  - Current transducers DCCT (Commercial Product or Self-design)
  - Self-designed digital electronics control module, which performs the current regulation, diagnostics, monitoring and local/remote service . It's standardized for all types of power supply
    - ✓ Key components that affect the current performance of power supply: DPSCM and DCCT

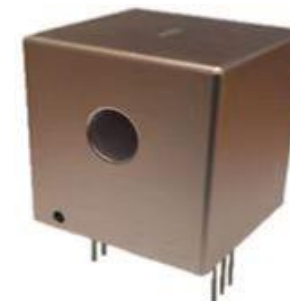
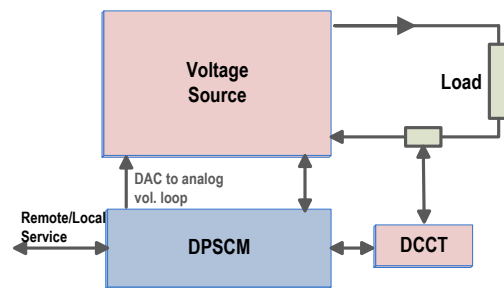
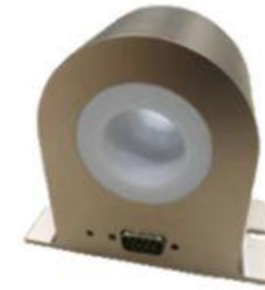
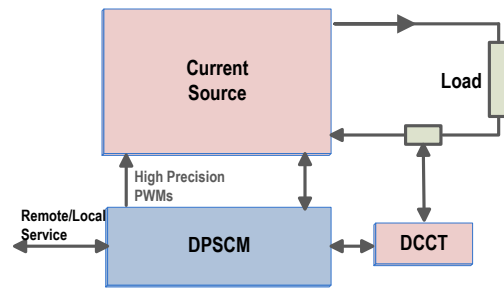

Functional diagram

DPSCM- Main board and ADC board

Self-design DCCT

# Design scheme

## ■ Interfacing with the power part

- Fully digital: the preferred solution for corrector ps; digital PWMs will be interfaced between the DPSCM and the power part.
- Digital current loop + other analog loops: open the field to more power supply producers who build quality products but may not have the experience in 10 ppm current control; open the field to any vendors who are good at a certain kind of topology; fast analog voltage loop up to 10kHz bandwidth with -30dB@300Hz, suppressing voltage ripples as much as possible; Resolution of PWM is not the limitation of high precision current regulation any more.

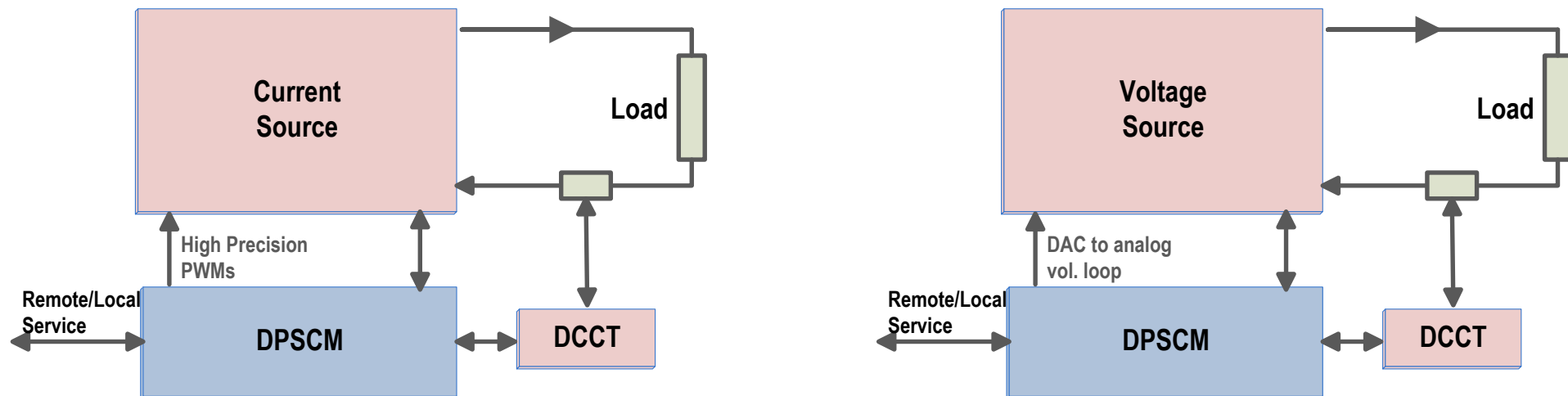

# Design scheme

## ■ SMPS

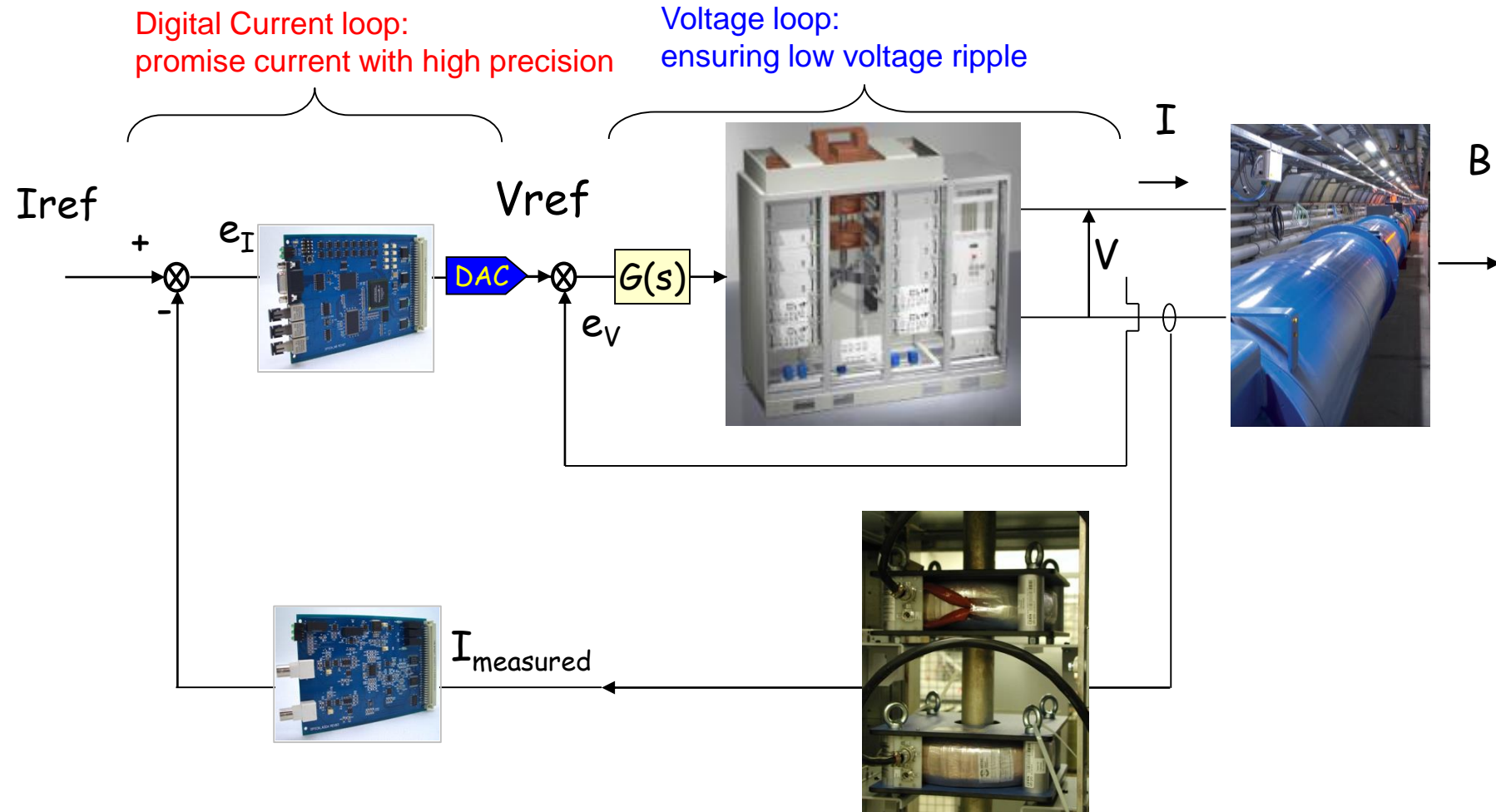



# Design and development

---

- **Booster power supply**
- **10ppm high precision power supply**
- **Fast corrector power supply**
- **Digital Power Supply Control Module (DPSCM).**
- **DCCT**

# Design and development

## ■ Booster power supply

- Repetition frequency above 10Hz: White type resonant power system (J-PARC, CSNS), energy fluctuations in the process of operation is stored by the resonant network.
- Repetition frequency below 10Hz: forced oscillation power supply (NSLS-II, SOLEIL, SSRF, HEPS). The power supply must have energy storage capacity to reduce the impact on the grid.
  - ✓ The booster power supply belongs to the two quadrant regulation current source, working in quadrant I, IV. In the current rise phase, the power supply outputs energy, the magnet consumes and stores energy, in the current fall phase, the magnet releases energy and consumes energy.
  - ✓ Key technical issue: dynamic tracking accuracy.

	CEPC	HEPS
<b>Output Rating</b>	520A/890V	900A/900V
<b>Stability</b>	500ppm	300ppm
<b>Repetitive frequency</b>	0.08Hz	1Hz
<b>Stability</b>	500ppm	500ppm
<b>tracking error</b>	0.1%	0.09%

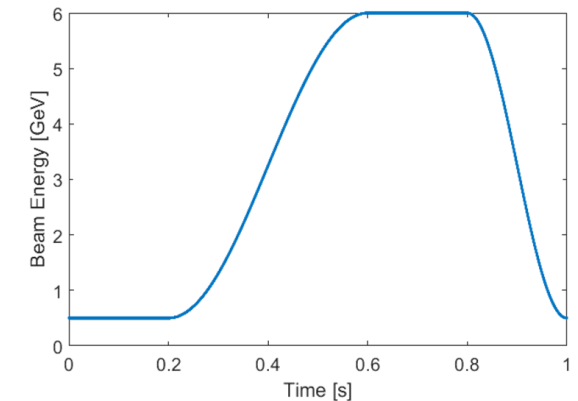
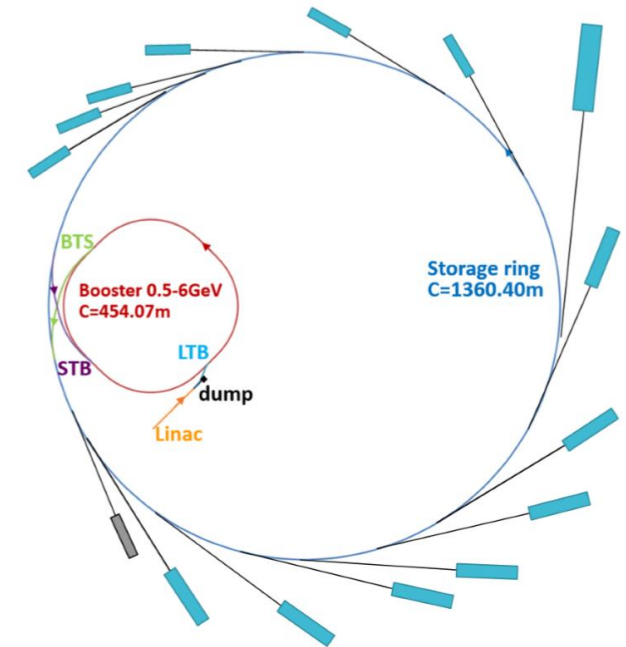

The magnetic field cycle waveform for HEPS booster

# Design and development

## ■ Booster Power Supply - topology

- AC-DC-AC structure
- Front stage rectifier circuit: diode rectifier + Booster.
- Output stage is the two-quadrant chopper,
- A power control circuit is used to reduce the fluctuation of input power

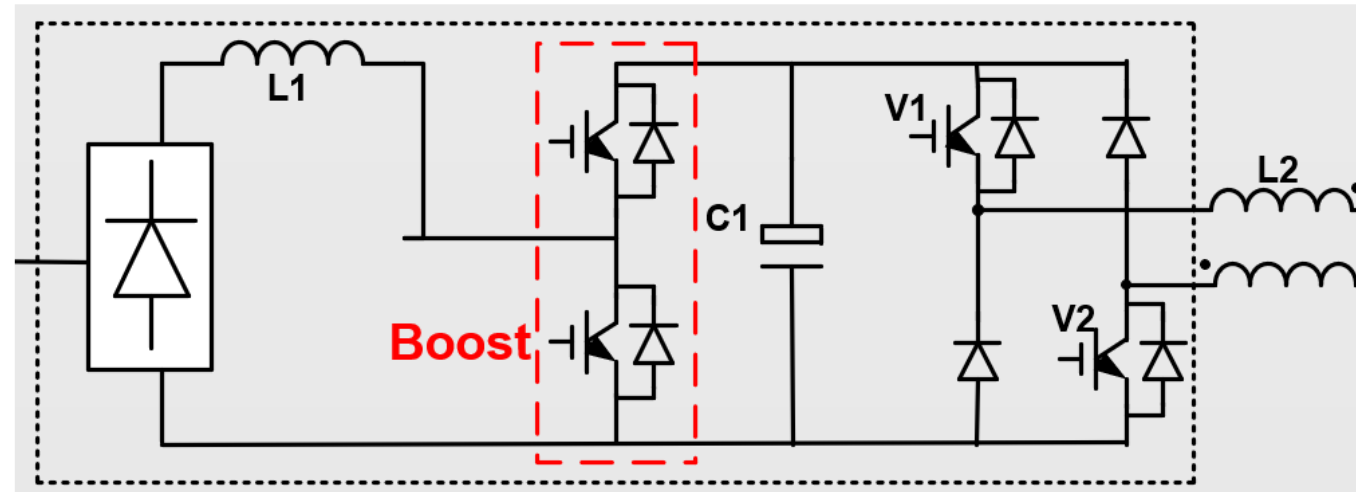

# Design and development

## ■ Booster Power Supply - topology

- Mature Multi – module series technology is adopted for high voltage output

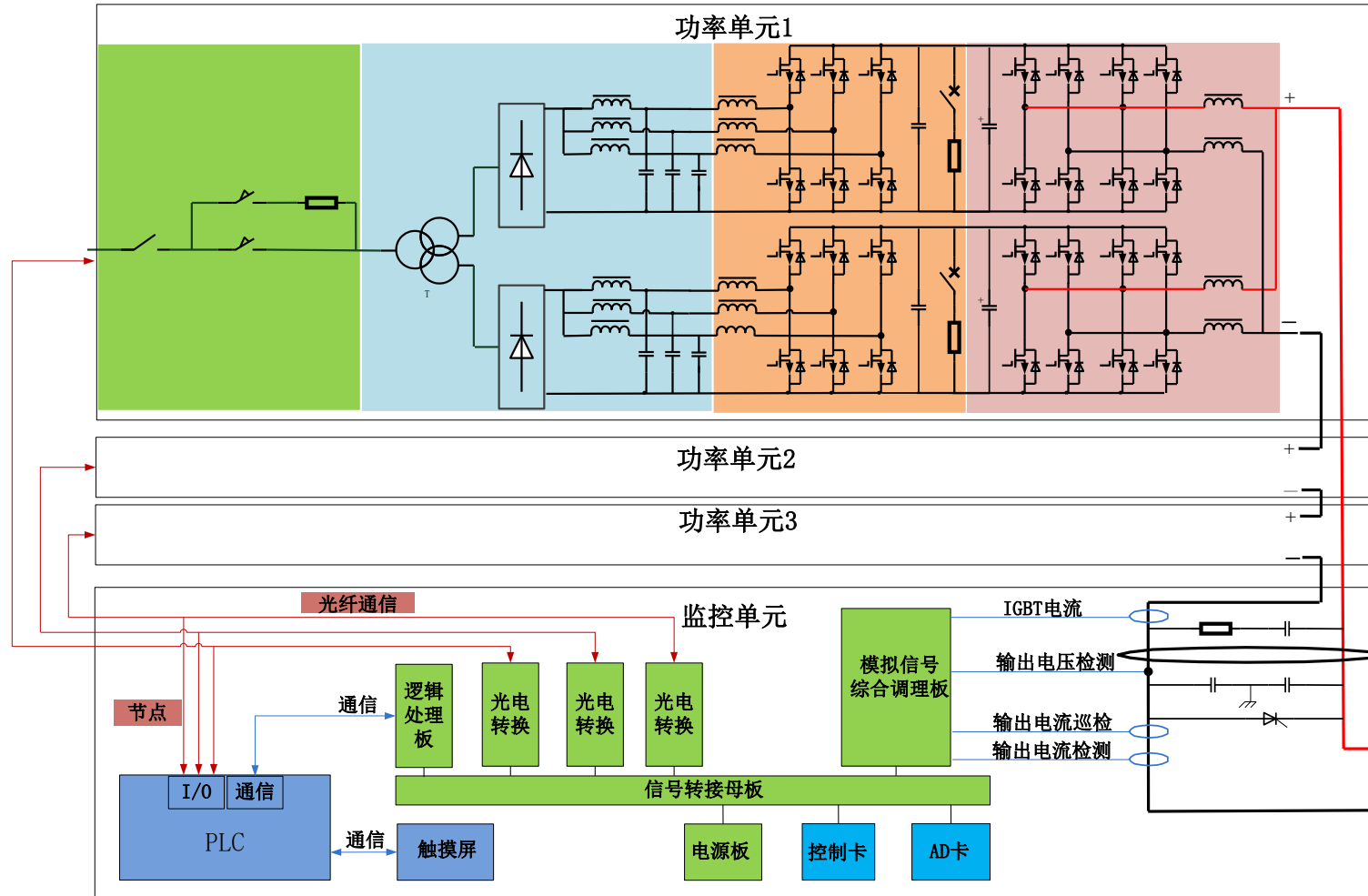

# Design and development

## ■ Booster Power Supply-topology

- Output control and multi phase-shifting PWM generator circuit be used to increase the cut-off frequency of power supply

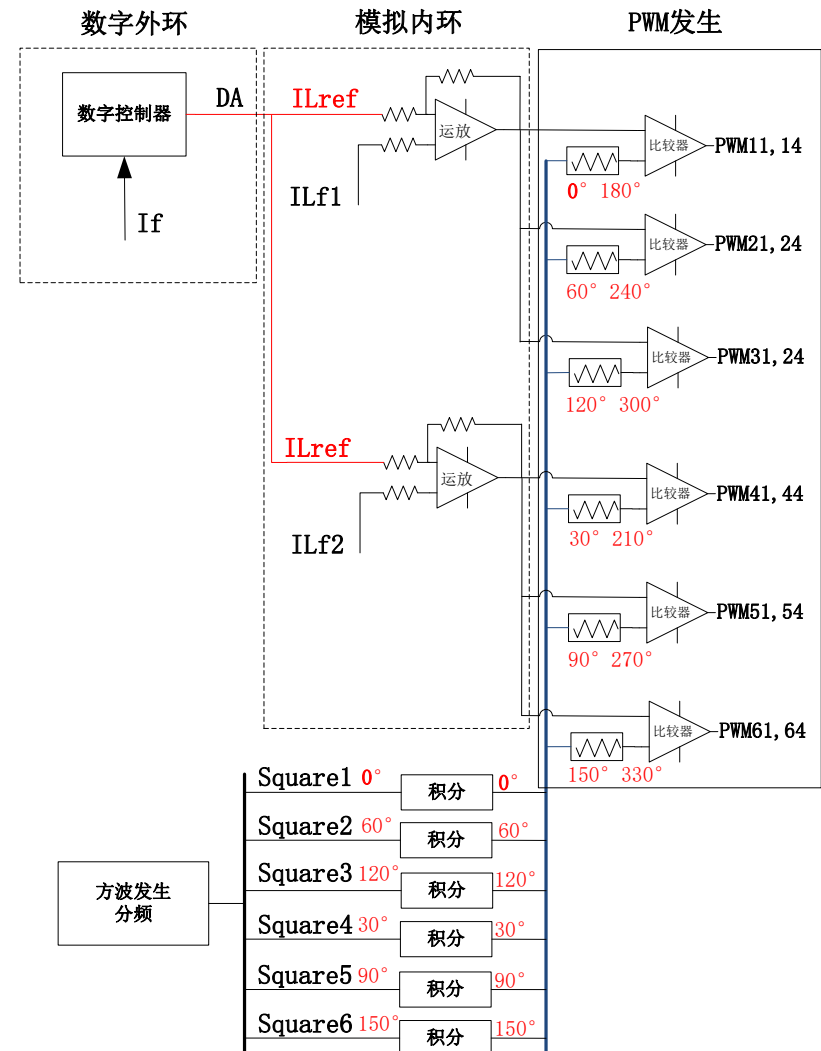

# Design and development

## ■ Booster Power Supply - topology

### ■ Simulation

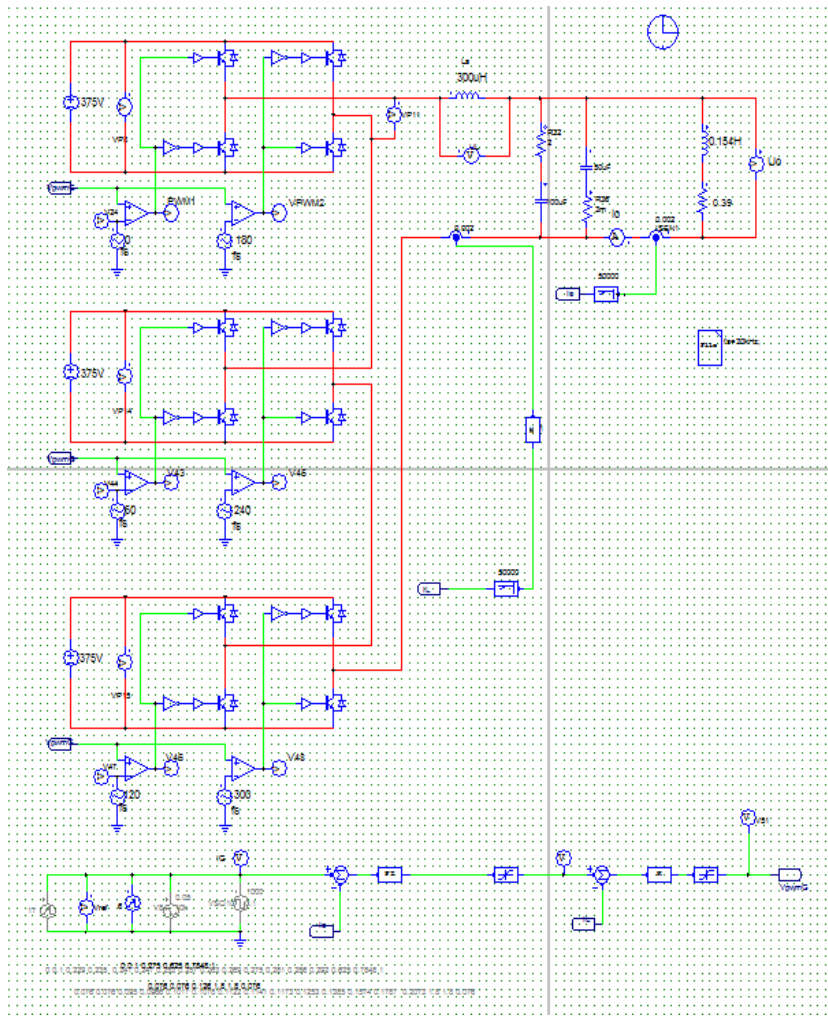

output stage simulation circuit

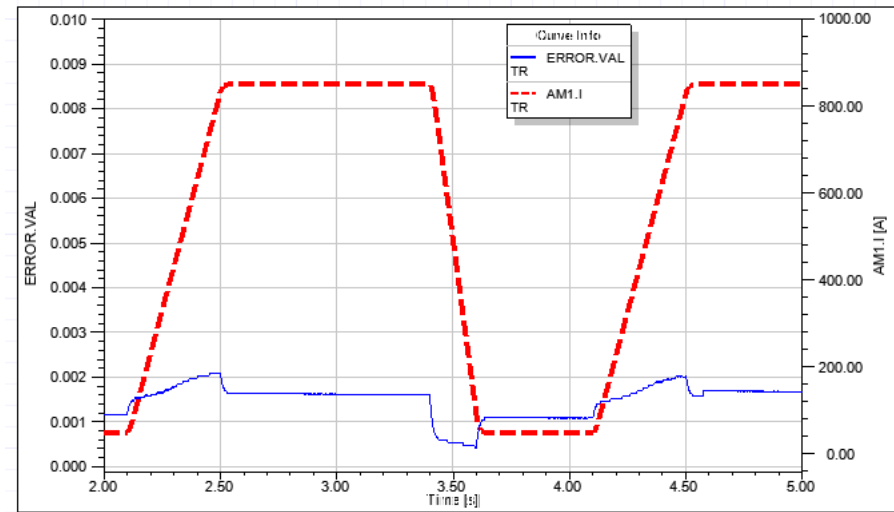
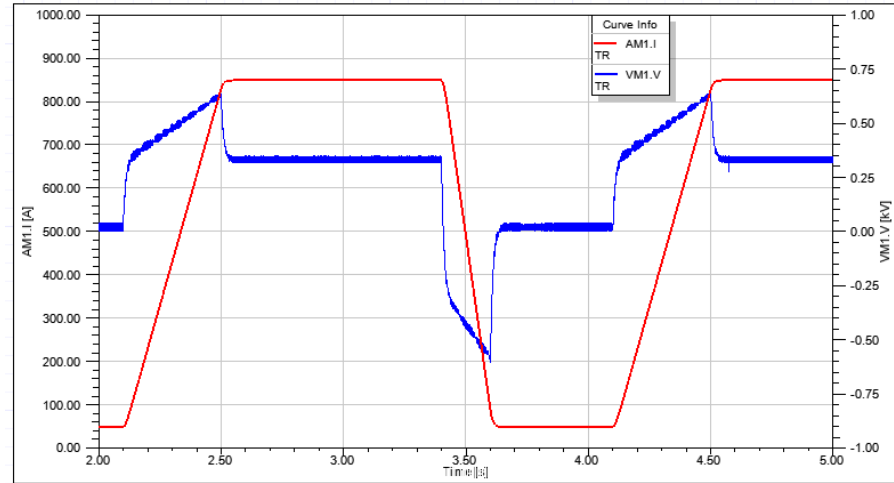

output current and tracking error waveform

# Design and development

## ■ Booster Power Supply - prototype



Prototype for HEPS magnet Measuring

Max	9.08873
Min	9.08845
Stability	1.55E-05

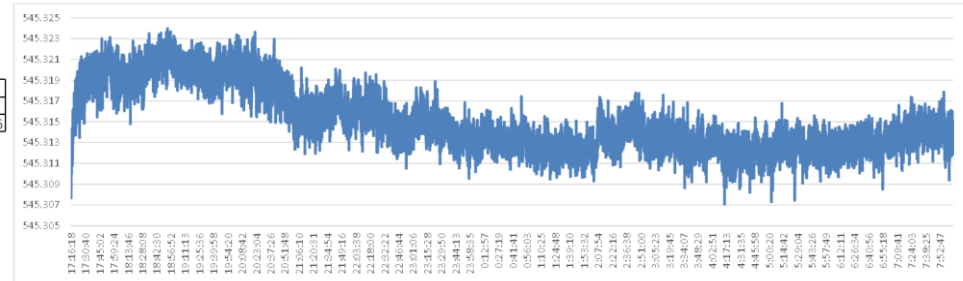

Max	18.03792
Min	18.03436
Stability	9.31458E-05

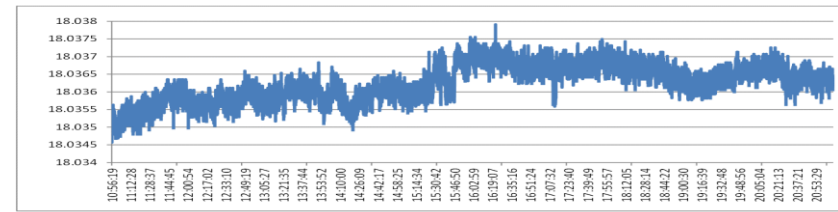

the stability meets the requirements



the formal power supply of HEPS booster magnet

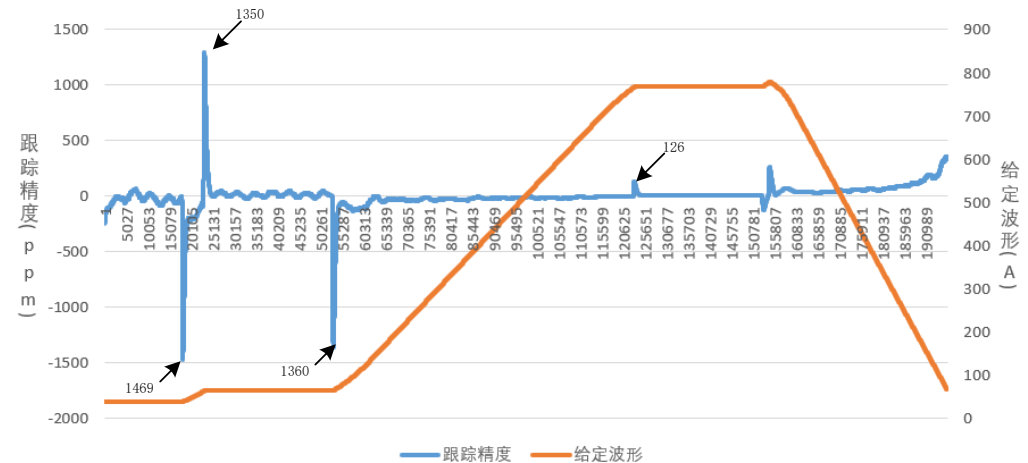

Current tracking waveform

# Design and development

## ■ 10ppm high precision power supply – parameter

Parameter	Power Supply					
	BD	Quad.	Sex.	Oct.	Normal Corrector	Fast Corrector
absolute accuracy (ppm, referred to $I_{max}$ )	100	100	100	100	100	100
stability(ppm, referred to $I_{max}$ )	<300 ms	10	10	20	20	25
	<10sec	10	10	20	20	50
	<8h	20	20	40	40	100
small signal BW (Hz)	-	-	-	-	-	10K
reproducibility(ppm, referred to $I_{max}$ )	50	50	100	100	100	100
current ripple(ppm, great than 50Hz, referred to $I_{max}$ )	TBD	TBD	TBD	TBD	TBD	TBD

## ■ topology

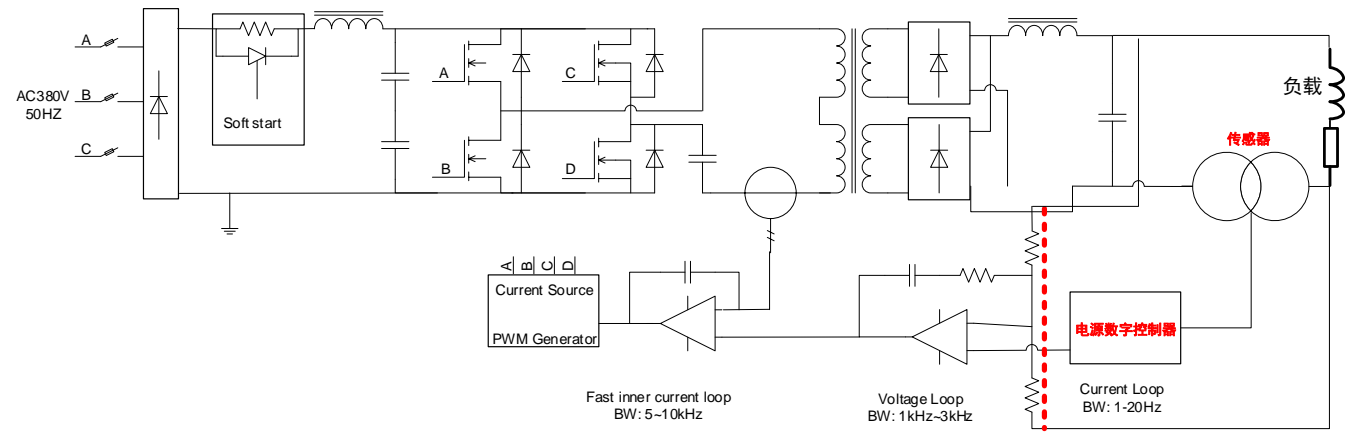

- Three-phase uncontrolled rectifier + single H-bridge inverter
- The type of the H-bridge switch tube: IGBT or MOSFET



# Design and development

## ■ 10ppm high precision power supply - Closed-loop control

- In order to reduce voltage ripple, it is recommended to adopt three - loop control structure
  - ✓ Outer loop: digital current loop
  - ✓ Middle loop: voltage loop
  - ✓ Inner loop: peak current loop of primary side of high-frequency transformer
- The peak current loop is used to improve the dynamic response of power supply and restrain the fluctuation of the grid

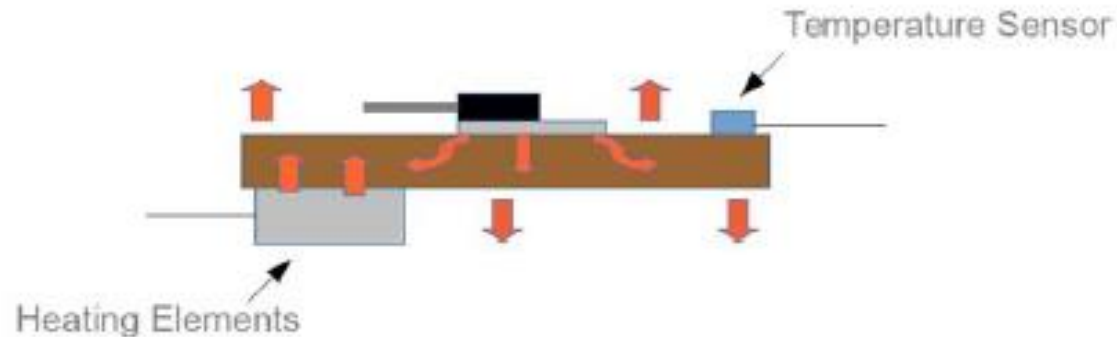

- In order to reduce temperature drift, the burden resistance of current type DCCT and ADC in digital controller have given special considerations
  - ✓ burden resistance : customized by company
  - ✓ ADC circuit: uses a constant temperature control circuit

# Design and development

## ■ 10ppm high precision power supply - prototype

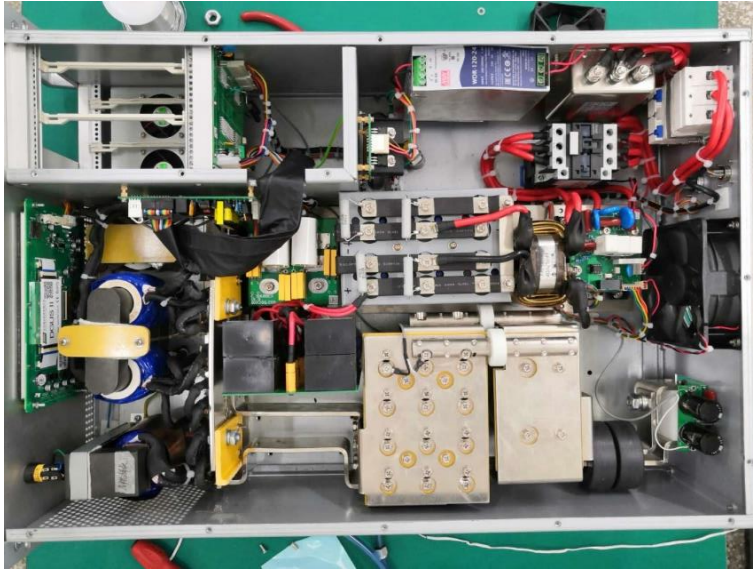

IGBT scheme

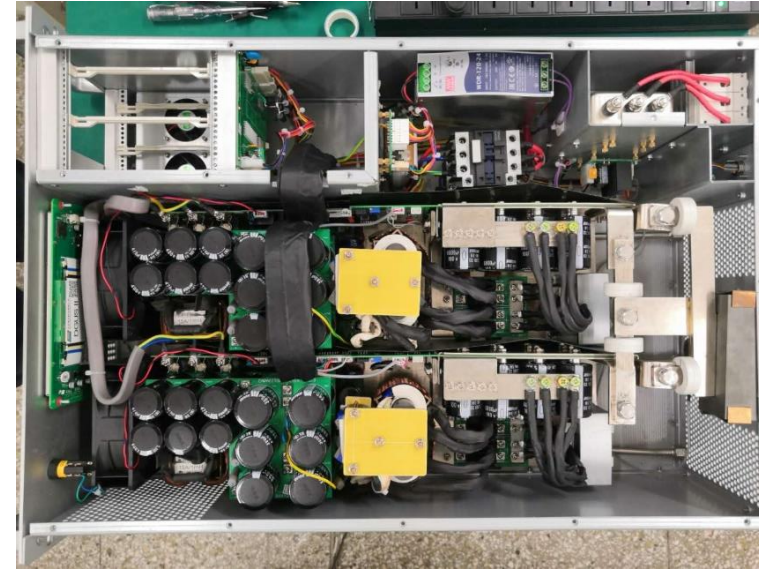

Dual-module MOSFET scheme

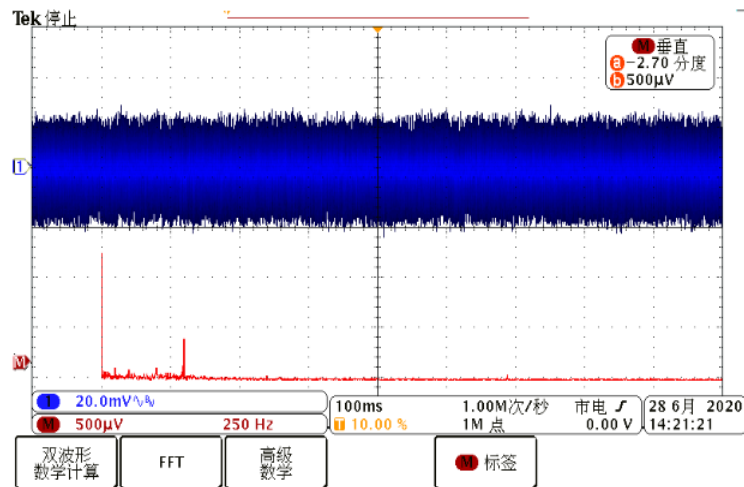

DPO3034 - 14:38:30 2020/6/28 星期日

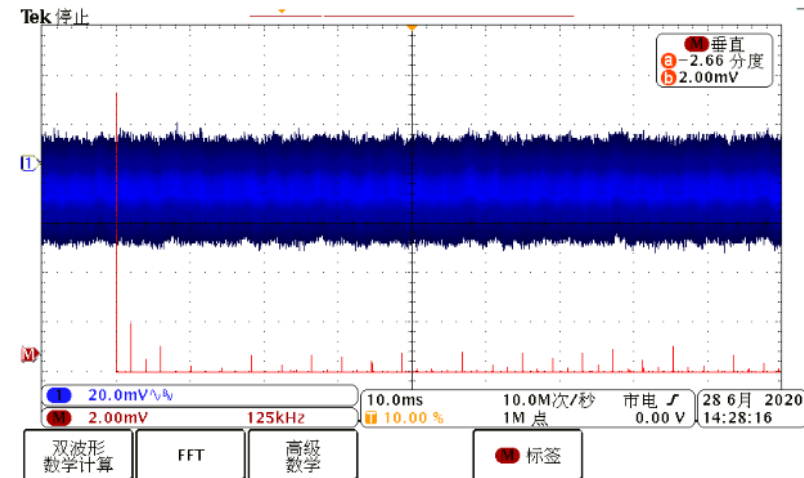

DPO3034 - 14:45:25 2020/6/28 星期日

# Design and development

## ■ Fast corrector power supply

- Fast corrector power supply is the execution unit of fast orbit feedback (FOFB) system
  - ✓ Fast dynamic response and high precision

名称	值
电源数量 (台)	384 + (48/2)
磁铁电感mH	13
电源规格	18A/80V
负载电阻 (mΩ)	75
小信号-3dB带宽 (kHz)	10
阶跃响应时间 (us)	≤75
输出电流纹波 (ppm)	20
输出电流分辨率 (bit)	18
输出电流稳定度 (ppm)	50

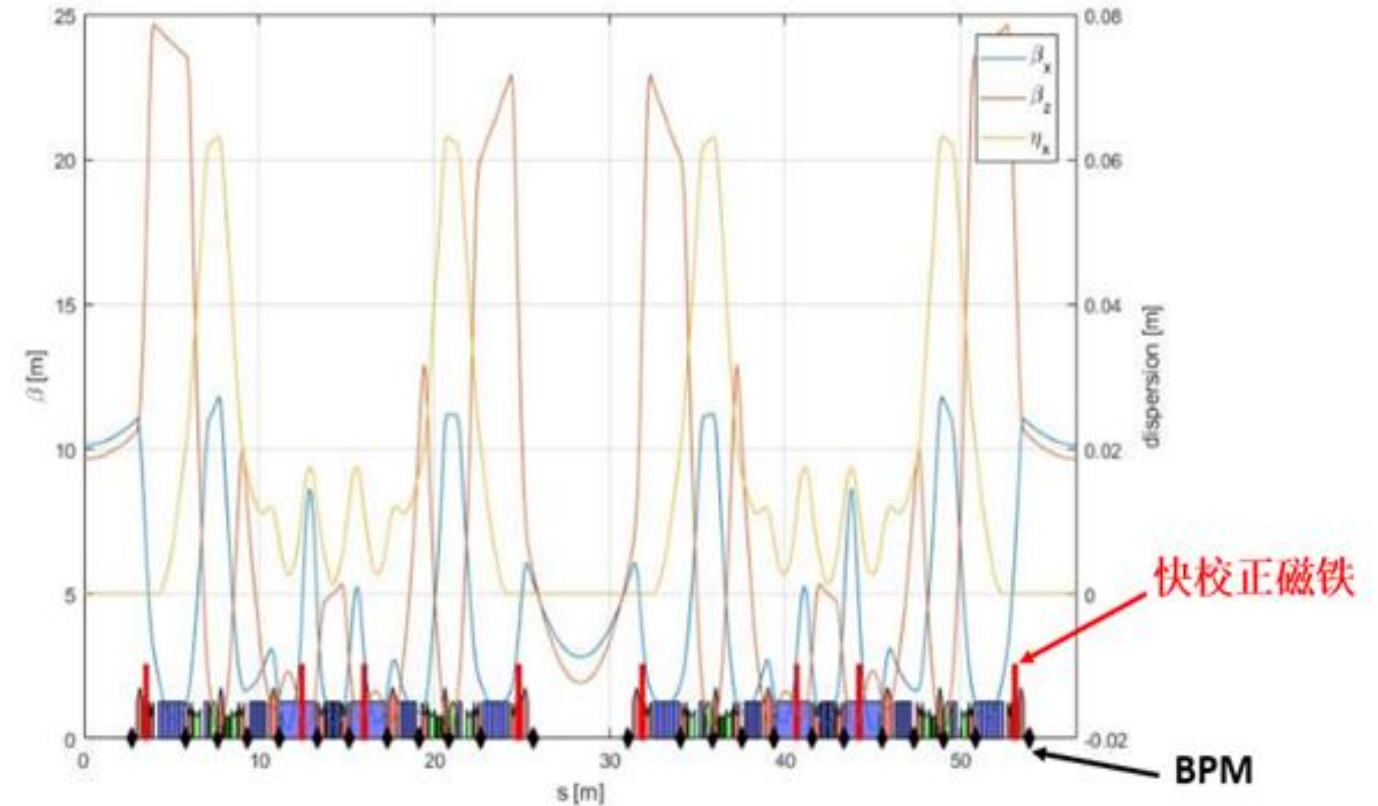

# Design and development

## ■ Fast corrector - Topology

- For fast corrector PS: switching-mode as the preferred solution
- Switching-mode ps design: 100kHz for each POWER MOSFET; and 50kHz cut-off freq. for output LC filter.
  - ✓ greatly reduce the size of output filter

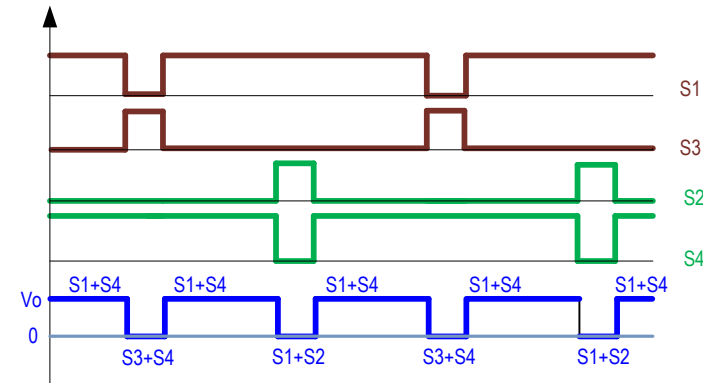
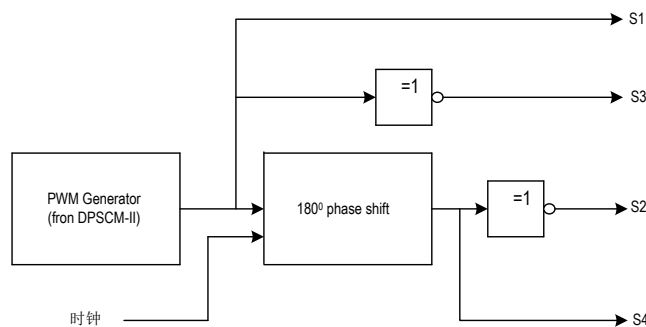
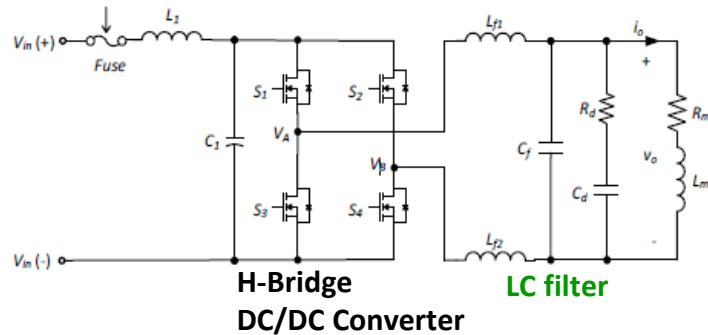

The freq. of output voltage before LC filter is **two times** of PWM frequency.

# Design and development

## ■ Fast corrector - Topology

- Adding a phase-lead compensator to the PI controller to increase the bandwidth of the closed-loop control system.
- It is difficult to achieve the 10kHz bandwidth and low current ripple at the same time.
  - ✓ Based on SM: with multi-level control strategy to increase the equivalent switching freq. and decrease the voltage ripple.

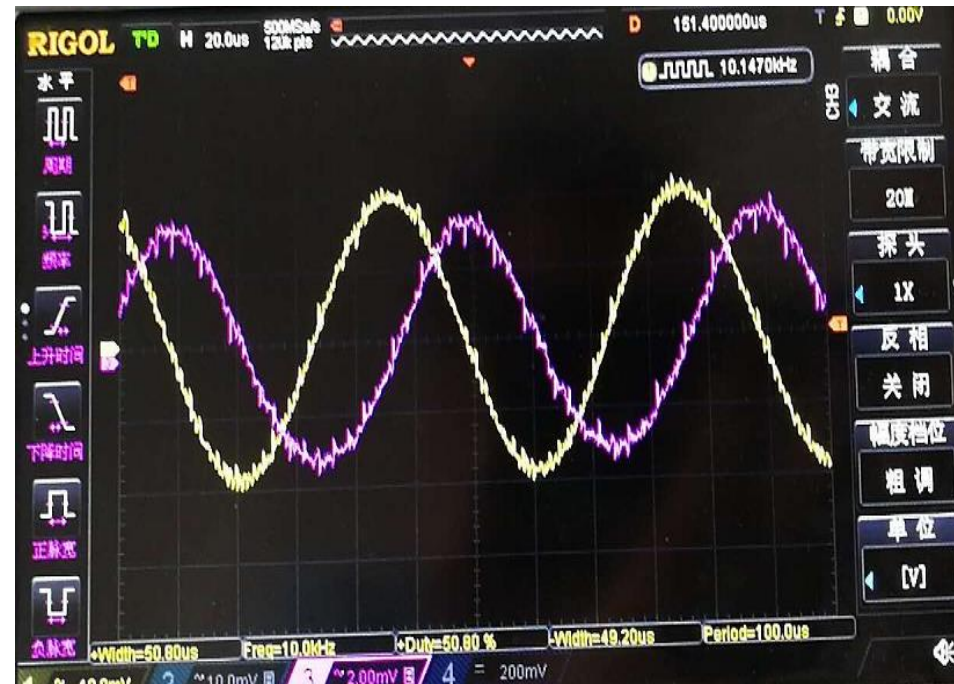
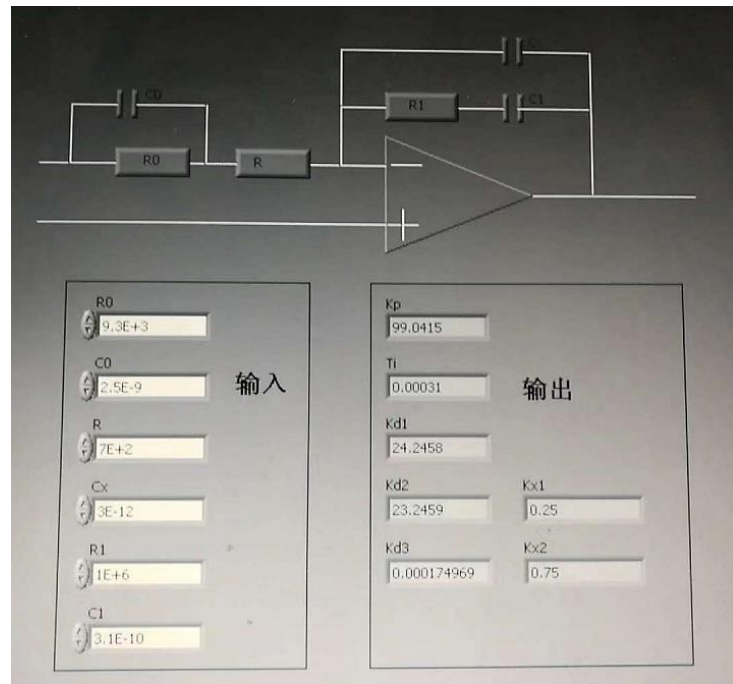

# Design and development

## ■ Fast corrector - Simulation

- Bandwidth: 0.15A @ 10kHz sinusoidal current output, amplitude attenuation -2.8dB, phase delay 39.5°
- Step response: 0 → 0.15A step current output, response time 62us

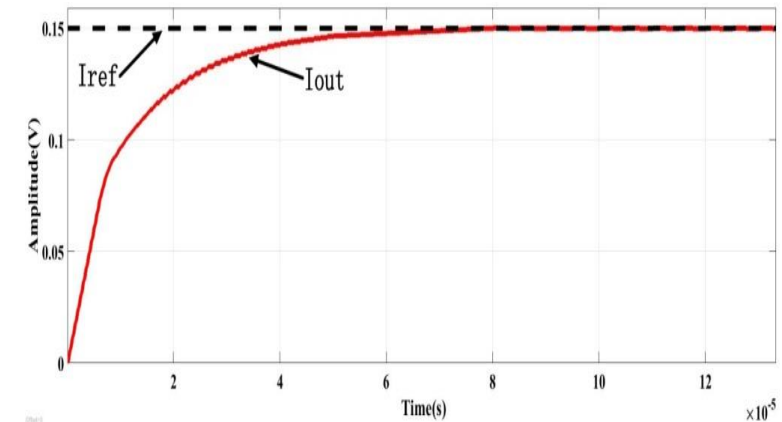
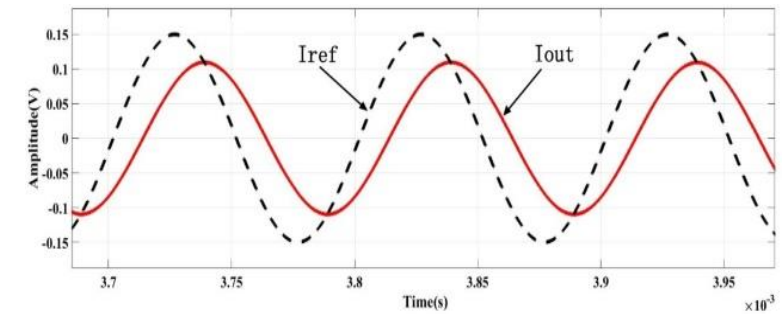
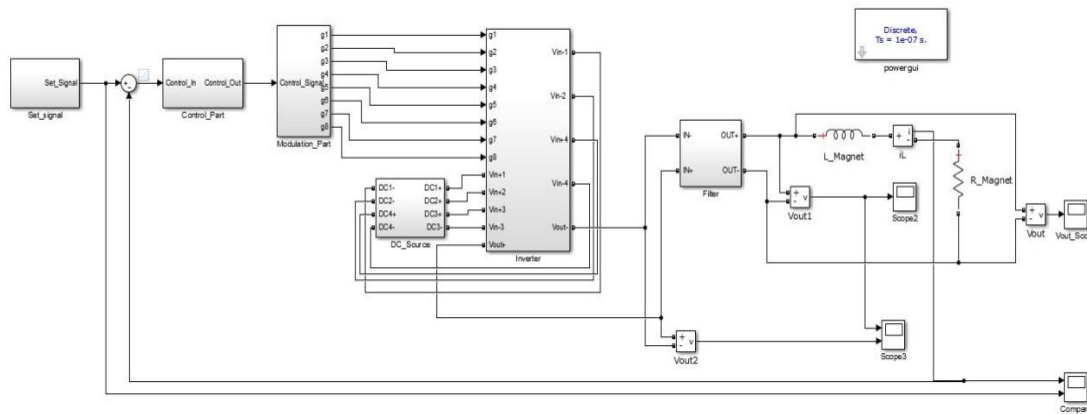

# Design and development

## ■ Fast corrector - prototype

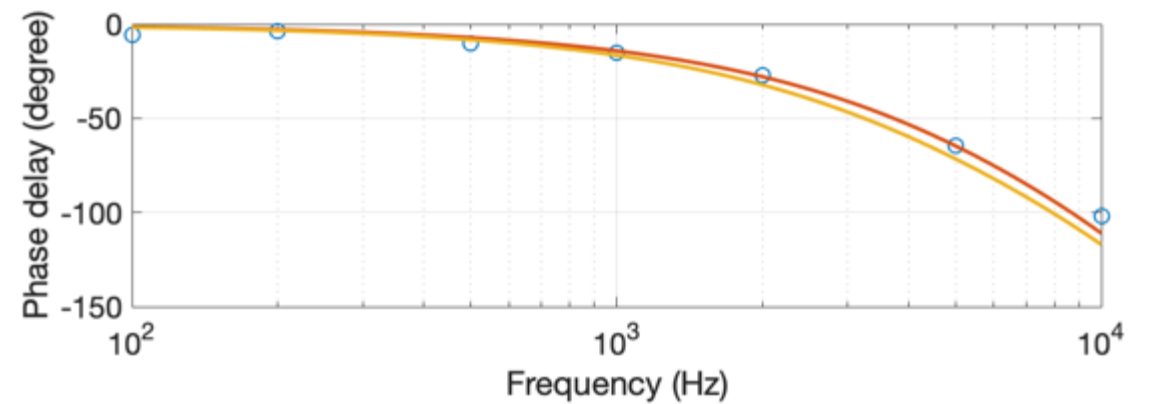
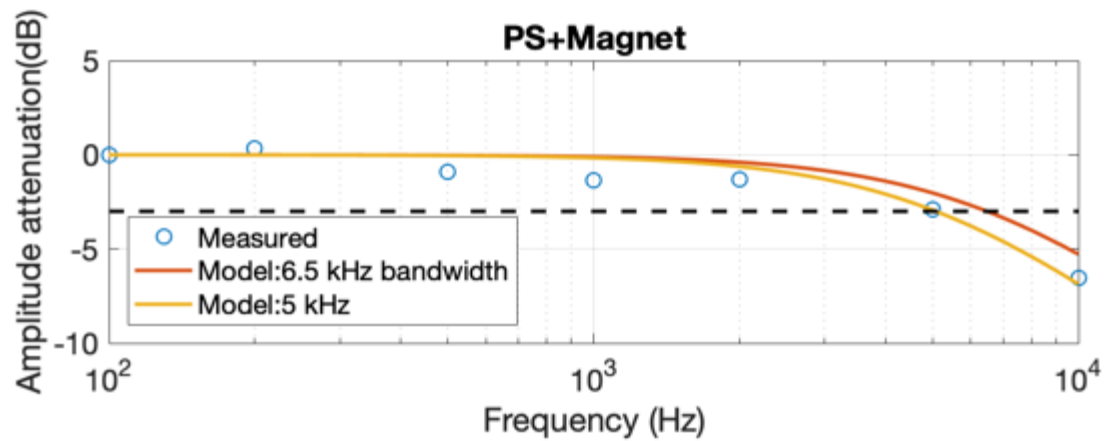
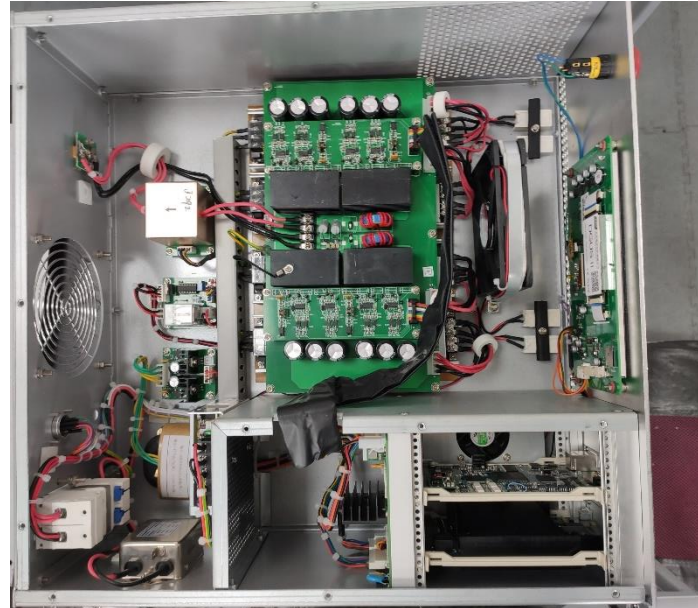
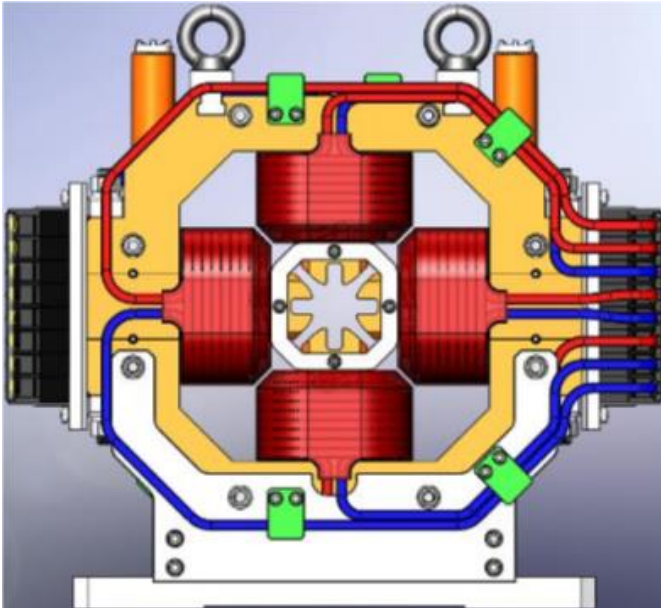

# Design and development

## Fast corrector - prototype

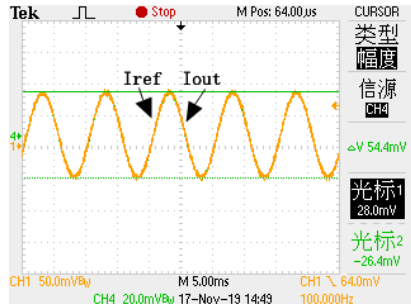

0.16A@100Hz

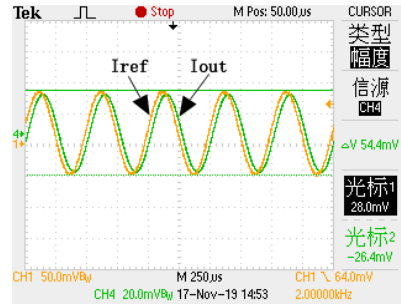

0.16A@2kHz

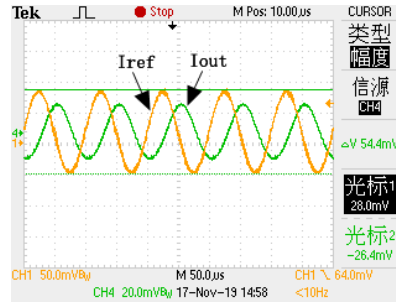

0.16A@10kHz

电流给定	幅值衰减 (dB)	相位延迟 (°)
0.16 A@ 100 Hz	-0.08	0.7
0.16 A@ 2 kHz	-0.36	36
0.16 A@ 5 kHz	-1.2	72
0.16 A@ 10 kHz	-2.7	105

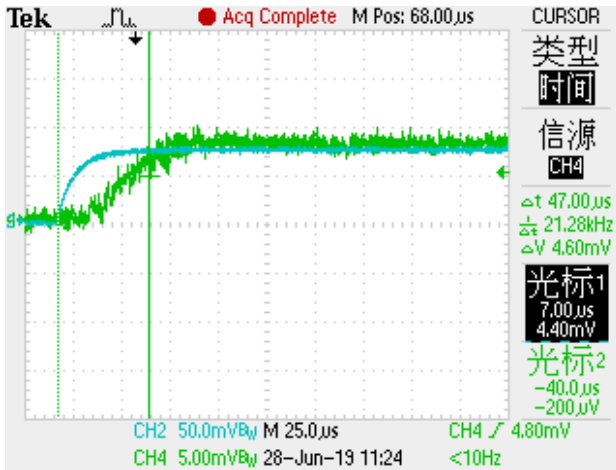

3→3.08A Step

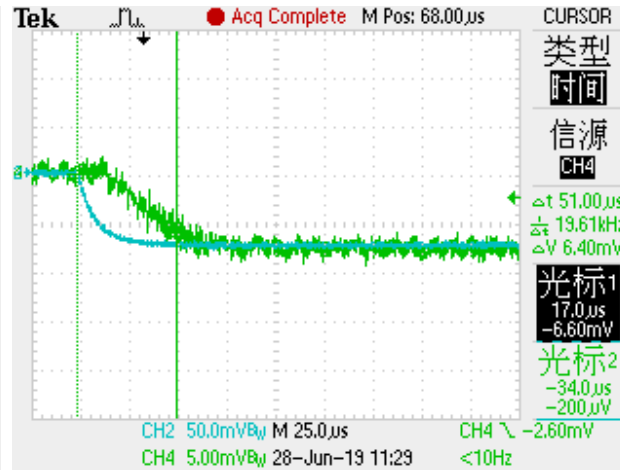

3.08→3A Step

阶跃电流给定 (A)	系统响应时间 (μS)
0→0.08	53
0→0.16	62
3→3.08	57
3→3.16	64
13.16→13	63
13.08→13	52
3.16→3	62
3.08→3	52
0.16→0	62
0.08→0	50



# Design and development

## Fast corrector - prototype

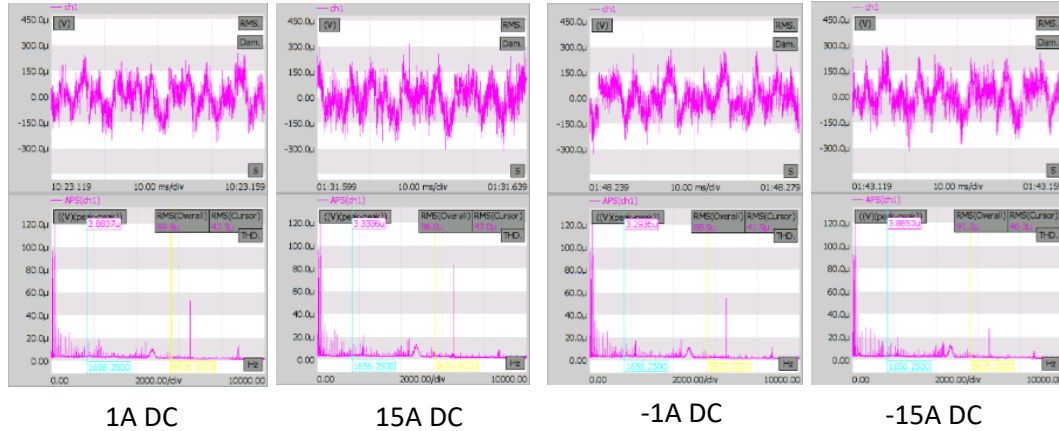

电流给定 (A)	FFT RMS ( $\mu\text{V}$ )	电流纹波 (ppm)
1	89.8	17.96
5	99.3	19.86
10	95.9	19.18
15	96	19.2
-1	88.9	17.78
-5	98.2	19.64
-10	92.2	18.44
-15	91.2	18.24

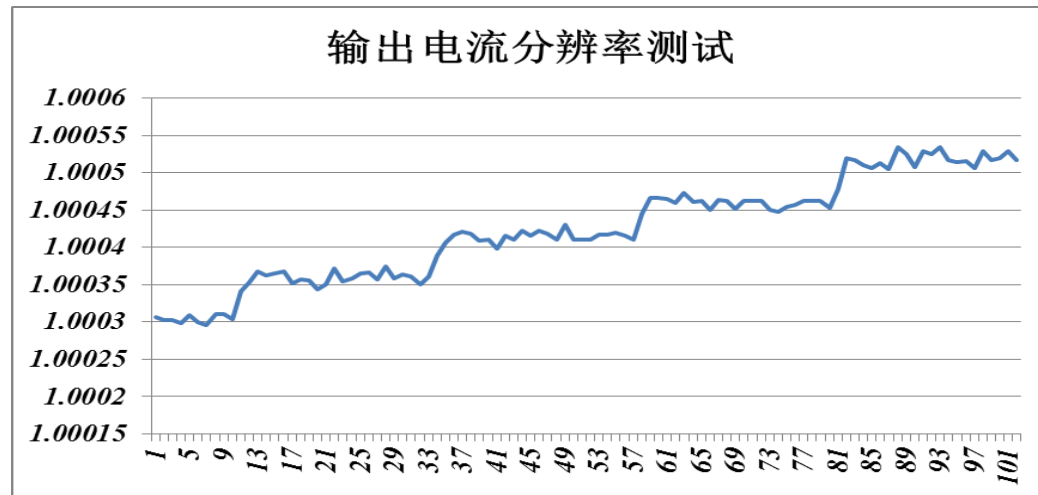

$$I_{resolution} = \frac{I_{Setp}}{I_N}$$

Output current resolution : **18bit**

# Design and development

## ■ Digital Power Supply Control Module (DPSCM)

- SOPC FPGA: System On a Programmable Chip
- All algorithms and peripherals control entirely implemented in one FPGA

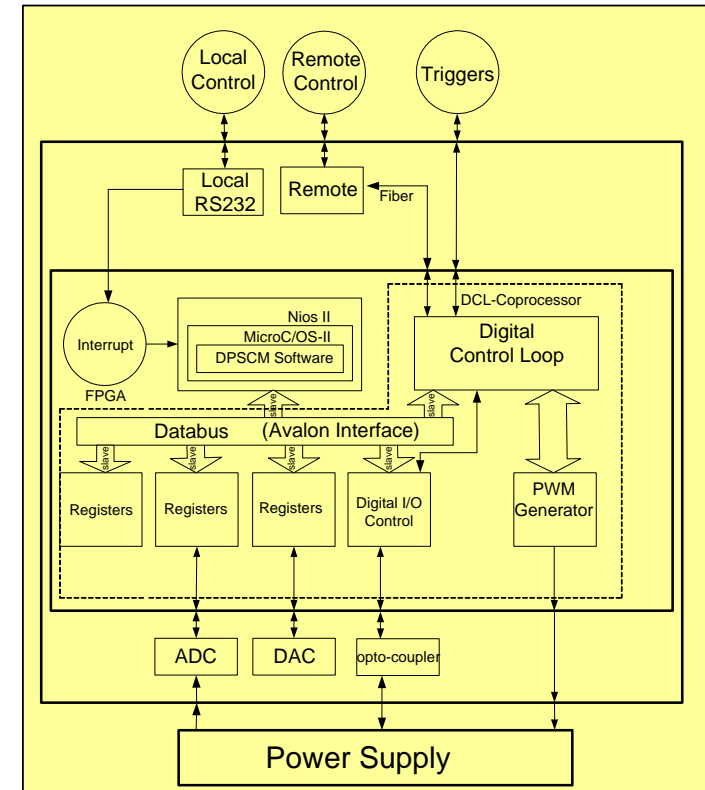
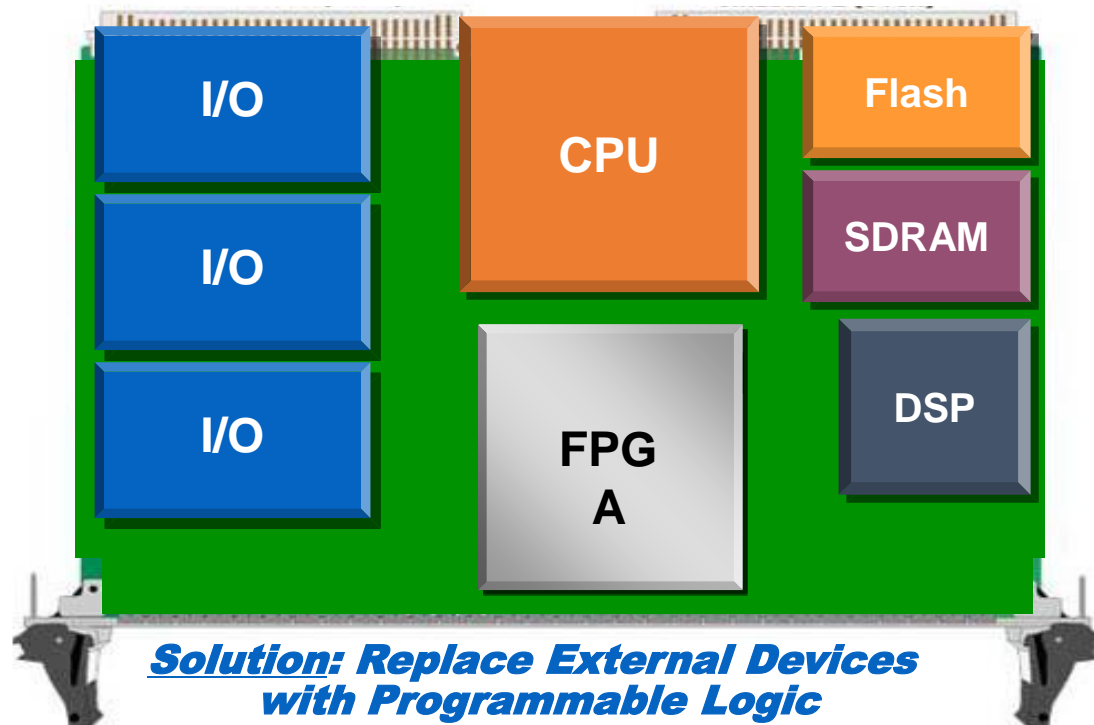

# Design and development

## ■ Digital Power Supply Control Module (DPSCM)

- **DPSCM-MB: PID + modern control theory**
- **high precision ADC board**  
**DPSCM-AD: temp control**
- **the voltage source**  
**interfacing board DPSC-DA**
- **the diagnostic board**  
**DPSCM\_MDA**

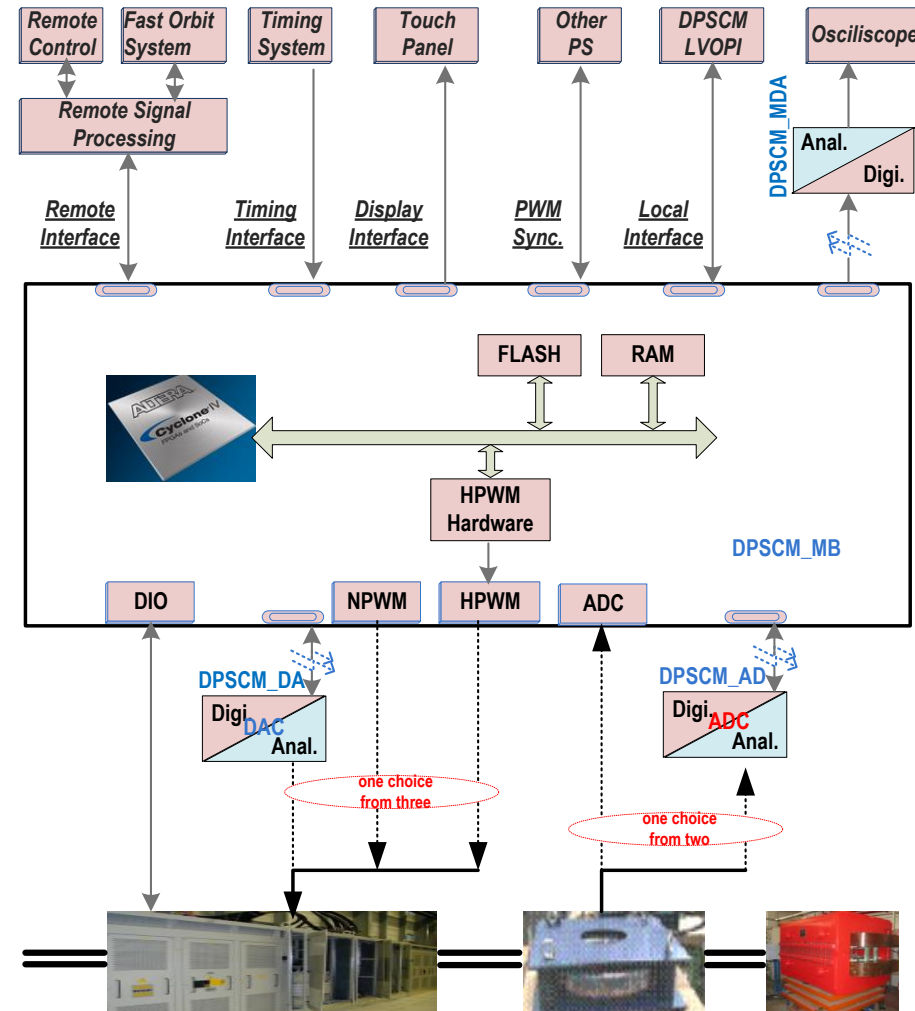

# Design and development

## ■ Digital Power Supply Control Module (DPSCM)

### ■ Hardware

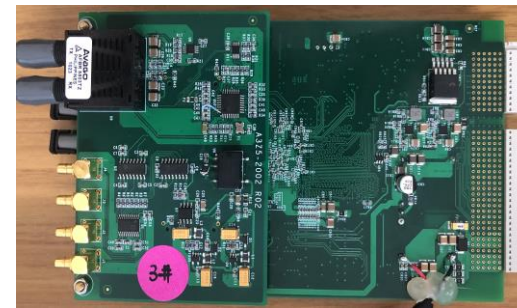
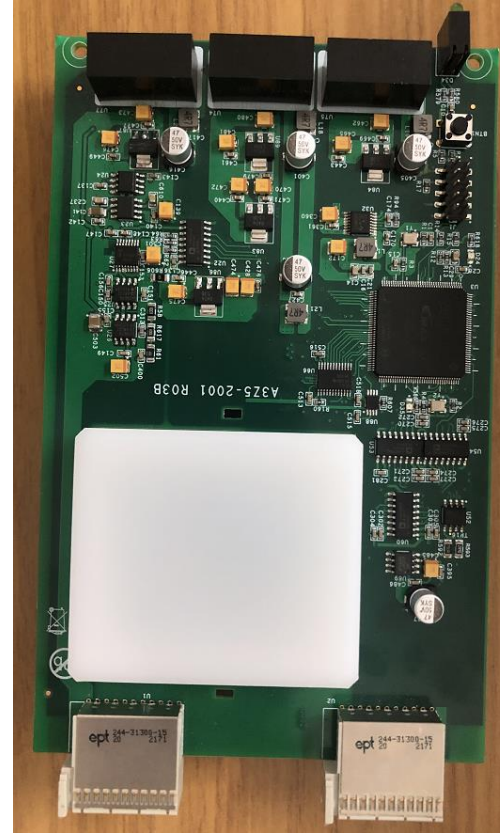

# Design and development

## ■ Digital Power Supply Control Module (DPSCM)

### ■ Software

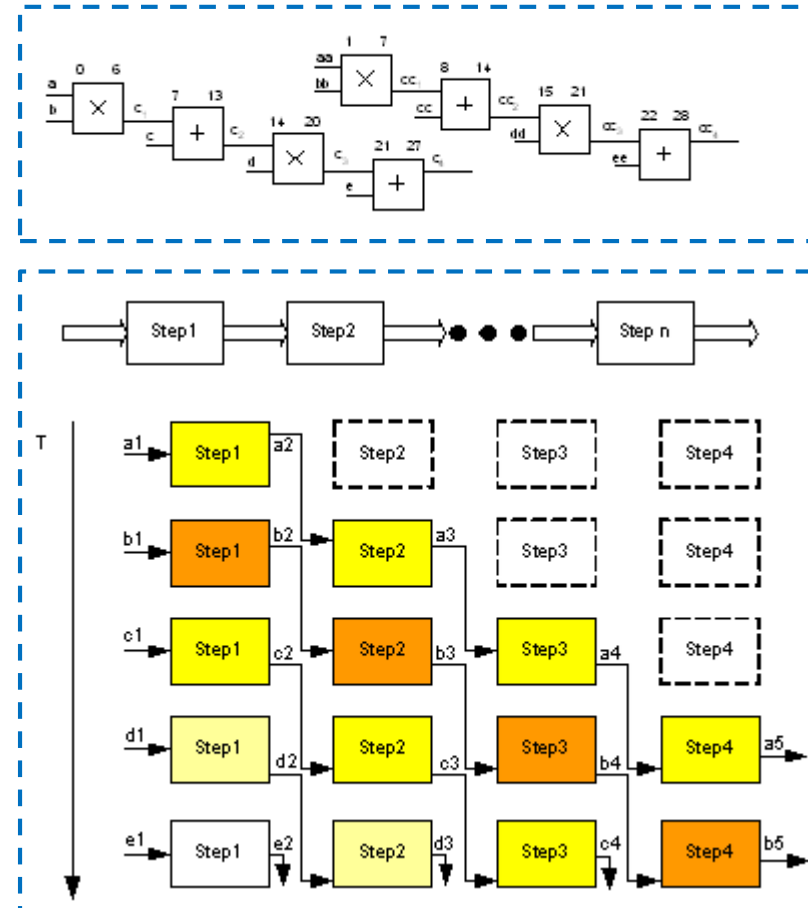
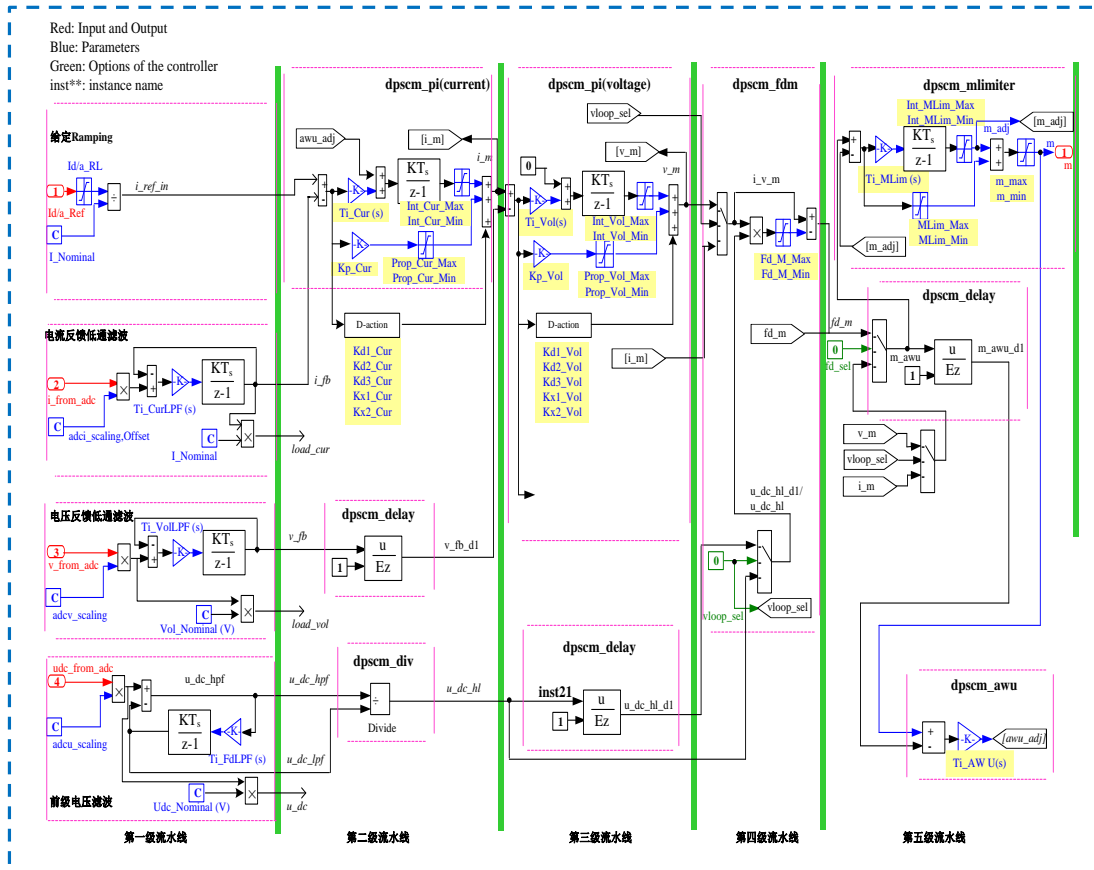

Modular time-sharing multiplexing

Pipeline design

✓ Balance between resources and speed of the digital controller is realized by using module time-sharing multiplexing and pipeline design

# Design and development

- **Digital Power Supply Control Module (DPSCM) :**
  - Test platform ( Closed-loop test system based on simulated load )
    - ✓ The controller underwent long time off-line testing before being installed into the power supply



# Design and development

## ■ DCCT

- Used at accelerators for magnet current measurement
- high stability, high linearity, high resolution and low temperature drift.
- Self-designed 300A and 20A DCCT, based on zero-flux principle.
- Key issue is to solve the problem of production technology



第I版 (HEPS-TF)

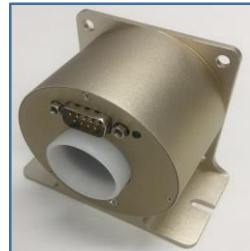

第II版

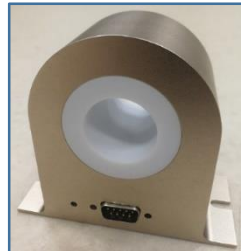

第III版 (HEPS)

可靠性、抗干扰性、稳定性等性能得到极大改善

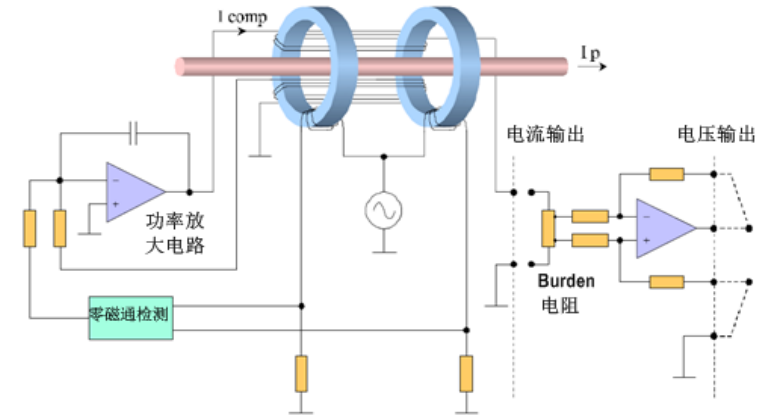

传感器	激励频率 (Hz)	带宽 (kHz)	分辨 (ppm)	线性度 (ppm)	噪声 (ppm)
第III版	90-100	380	0.1	1.2	1.3
第II版	130-150	350	0.15	1.2	1.5
第I版	80-90	350	0.15	1.2	2
HITEC	80-90	275	0.2	2.5	1
DANYSENSE	31k-32k	995	0.5	2	1.5

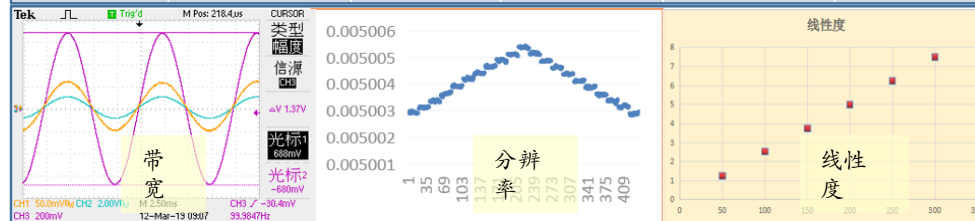

# Design and development

## ■ Current transducers— 20A prototype

- On the basis of the 300A: calculation of magnetic circuit parameters, improvement of circuit noise, structure design.
- 20A-DCCT was successfully developed
- Resolution  $\leq 0.5\text{ppm}$  (10uA), linearity  $\leq 1.5\text{ppm}$ , noise  $\leq 1\text{ppm}$  (maximum noise point)

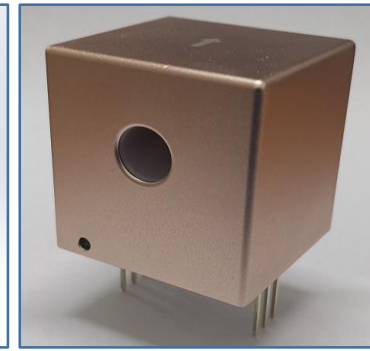
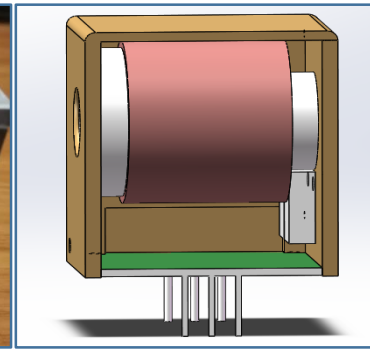
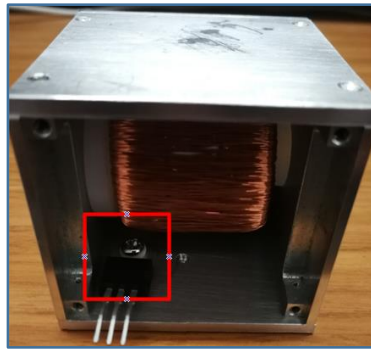
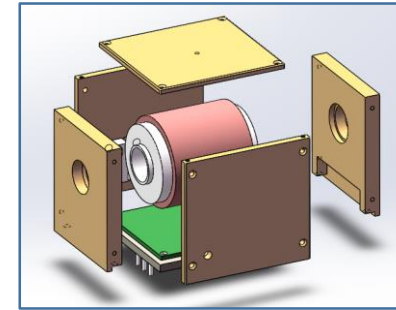
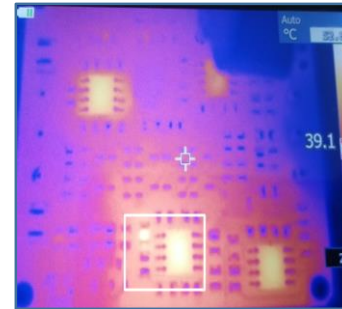
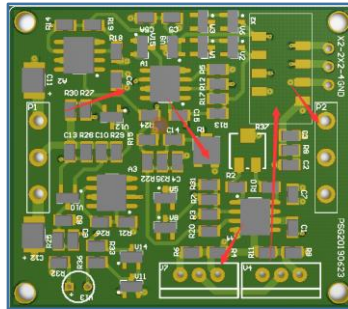
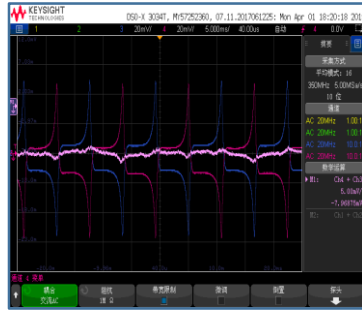



# Design and development

## ■ Current transducers— 300A prototype test

- In order to ensure the reliability and stability of the self-made DCCT, long-term performance tests have been carried out in different HEPS power sources
- HEPS 10ppm high precision power supply, stability is better than 8ppm

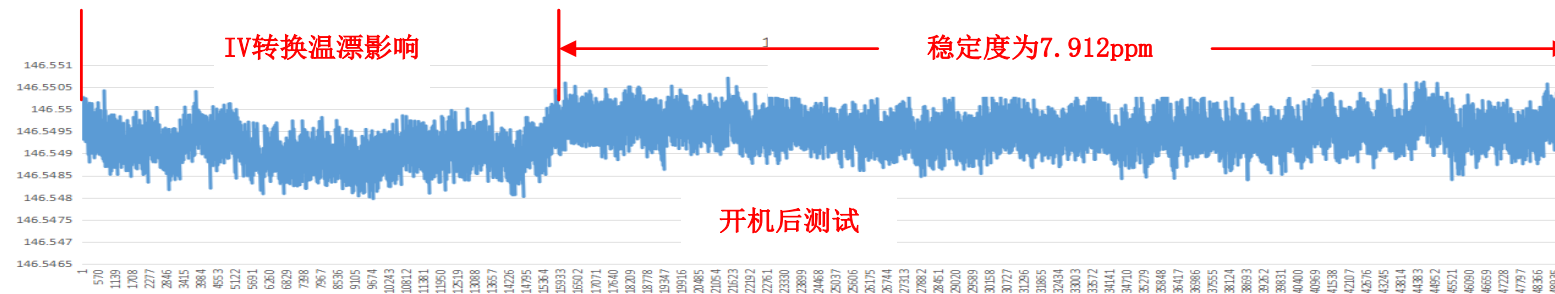

# Summary

---

- Three types of power supply: booster dynamic power supply, high precision power supply, fast corrector power supply
- Two key components: DCCT and digital controller
- All power supplies and devices have been developed and applied in HEPS
- The technological design of power system will determine the reliability of power supply system operation in the future
- Quality control of so large number of power supplies is very challenging.



Thank You!

