

Raios Cósmicos nas Escolas

O Hardware e suas possibilidades

G. Saito, M. Leite, M. Kuriyama, R. de Paula, R. Menegasso

Instituto de Física da USP



24 de Fevereiro de 2021

Hardware

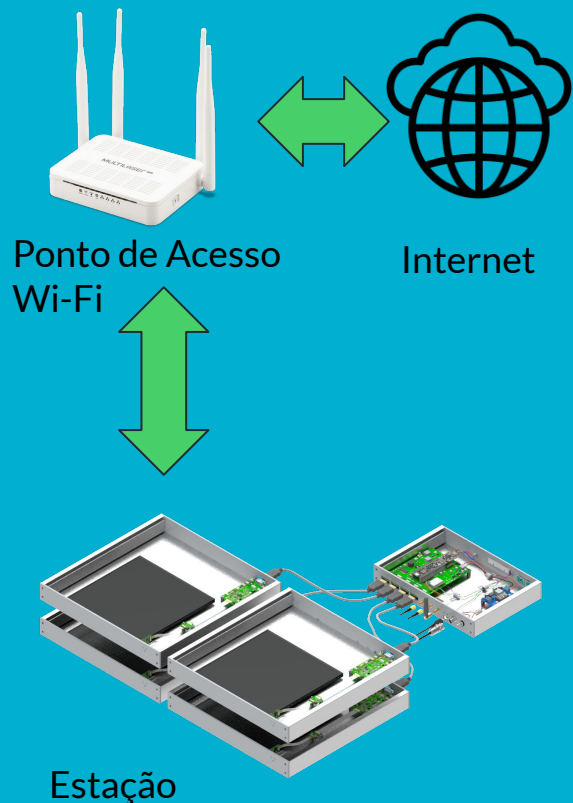

Software

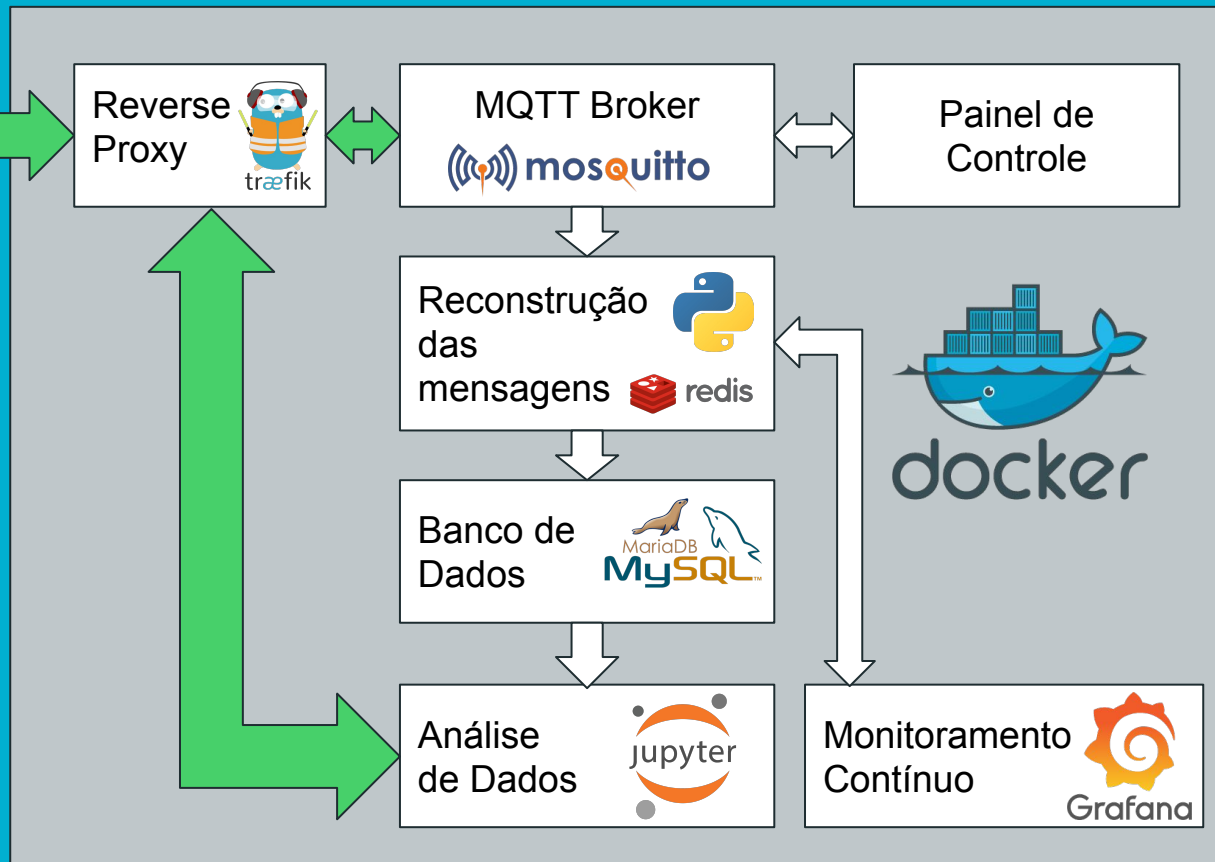

Anatomia da estação

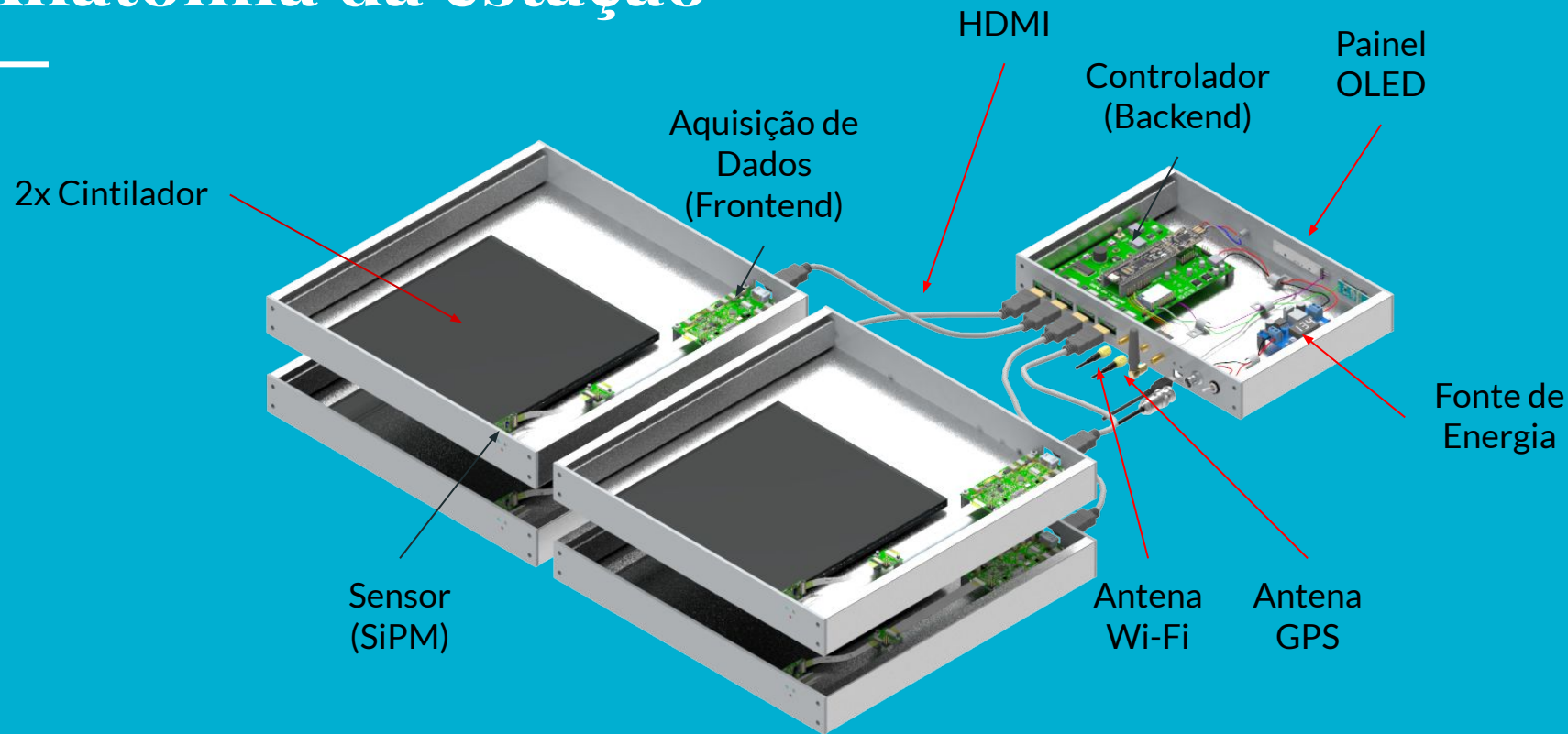

Funcionamento

Requisitos do local:

- Energia elétrica
 - Fonte de laptop
- Conexão com a Internet
 - Wi-Fi
 - Ethernet (cabo)
- Sinal de GPS
 - A antena pode ficar longe da estação
 - Mais sensível que a antena do celular



Software

Para rodar o software, tão simples quanto:

```
$ git clone gitlab.com/cosmicserver
```

```
$ docker compose up
```

- Funciona em qualquer máquina Linux
- Configuração pronta

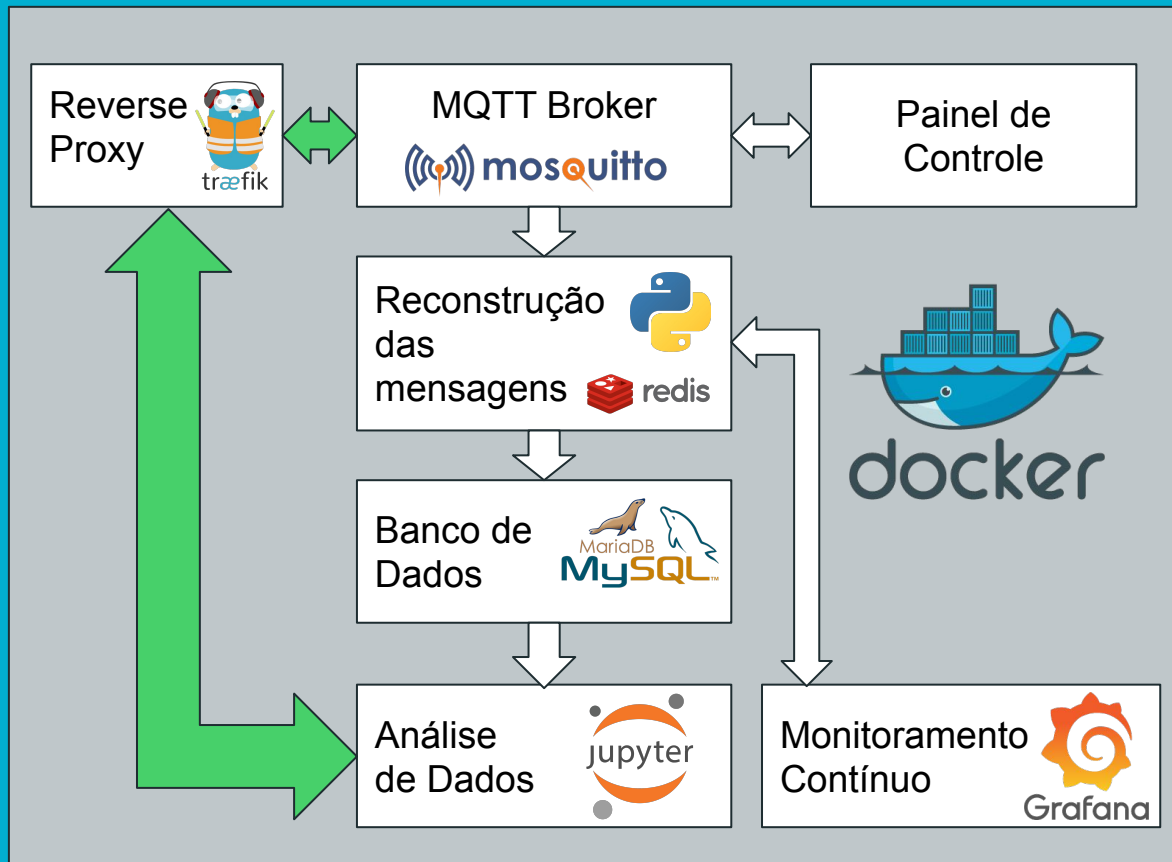

Grafana

Visualização em tempo real do sistema e das estações

- Eventos
- Status das Estações
- Condições de operação
- Mapa
- Servidores

Acessível em raioscosmicos.if.usp.br/grafana

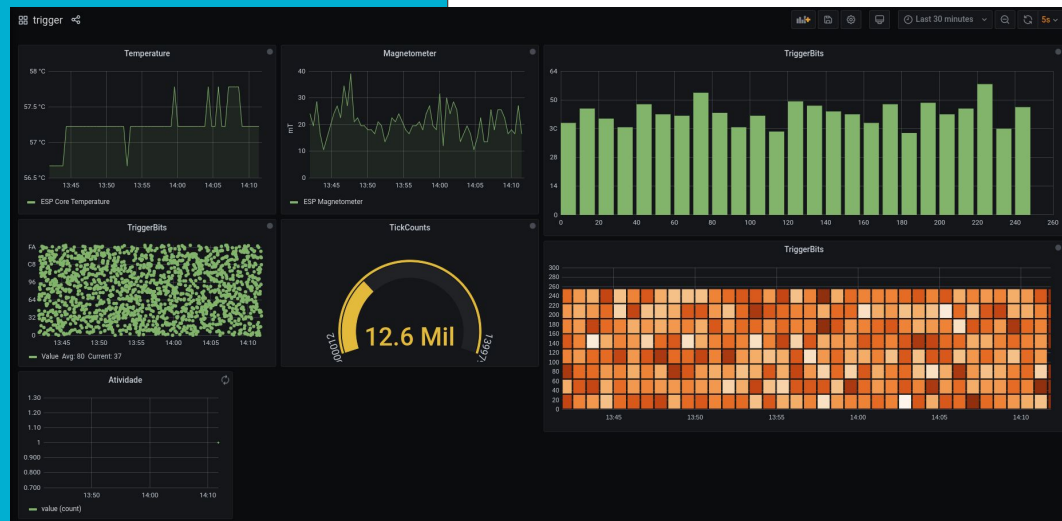
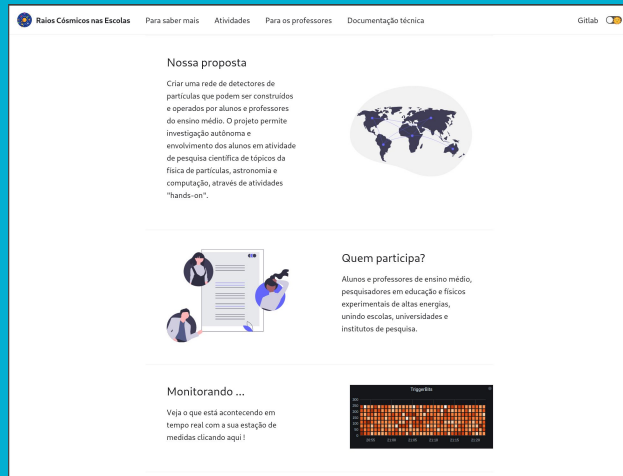

Possibilidades

Muitas organizações usam Grafana

- Qualidade dos dados
- Análises em tempo real
- Mapas
- Filtros
- Alarmes

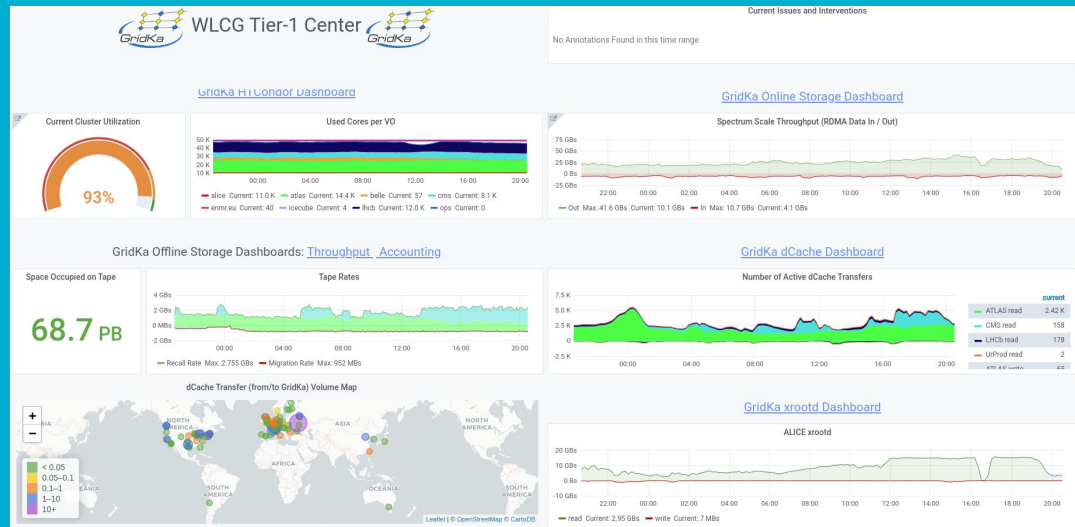

Status das estações

- 1 estação montada
- Material para 3~4 outras estações
- Parado desde Março/2020

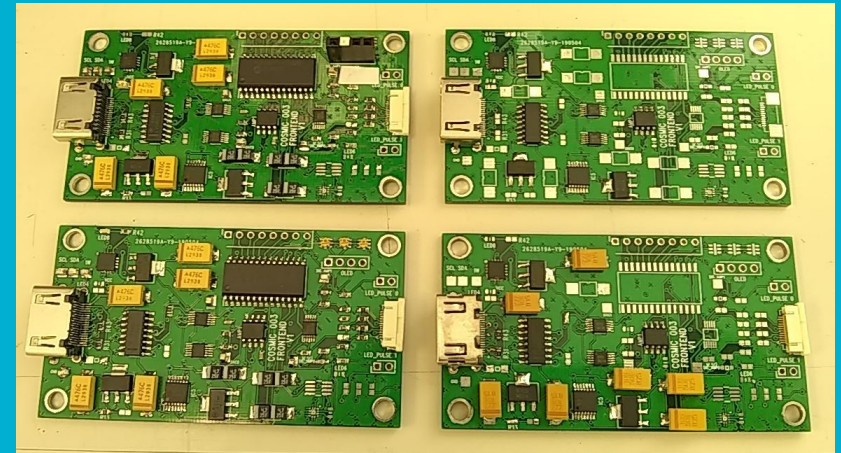
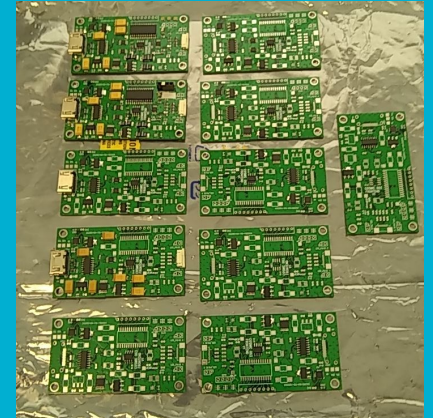

Evolução do Hardware

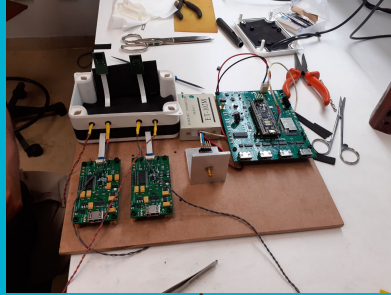

07/2018

06/2019

08/2019

01/2020

02/2021

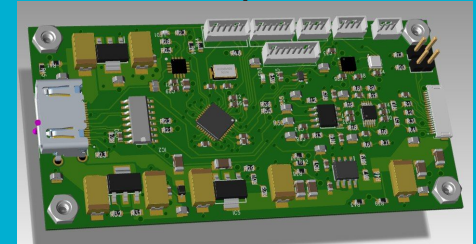

Nova versão do Hardware

- Segunda versão
- Mais simples de operar
- Mais possibilidades de uso
- Experiência da versão anterior
- Enviando para fabricação

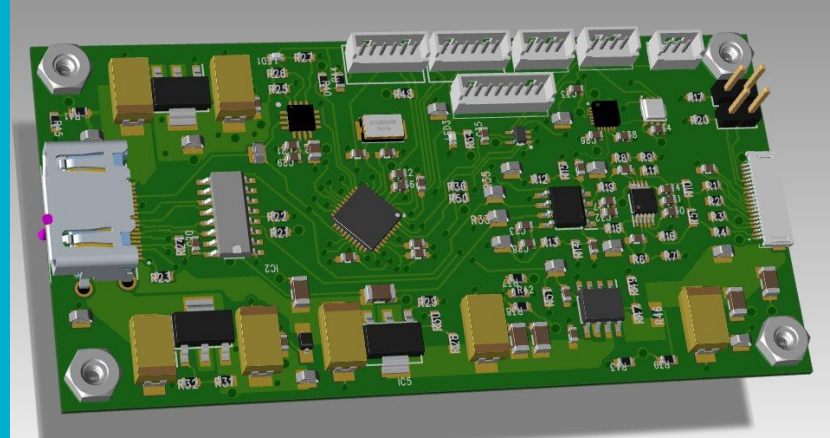

Feedback é sempre bem vindo

Obrigado!

Backup

Frontend + SiPM (Cintiliador)

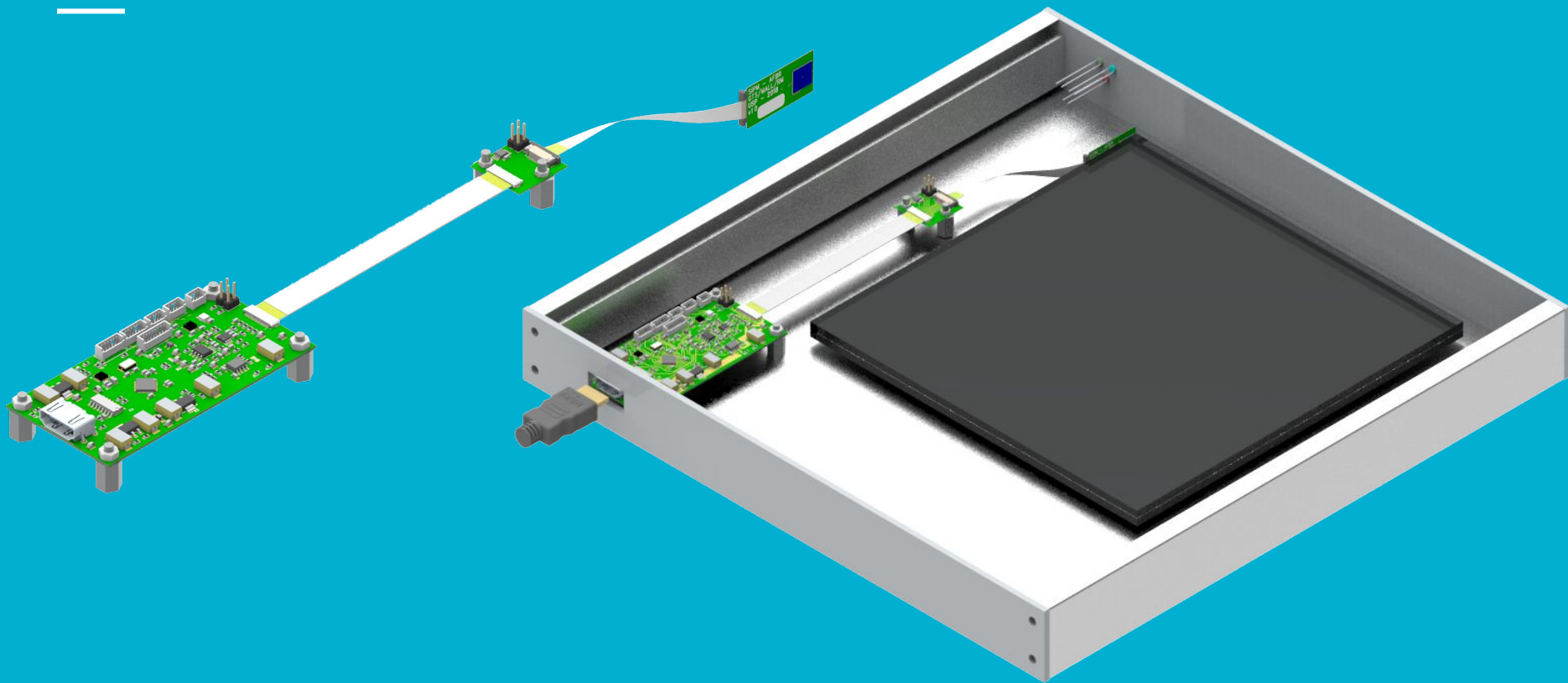

Backend

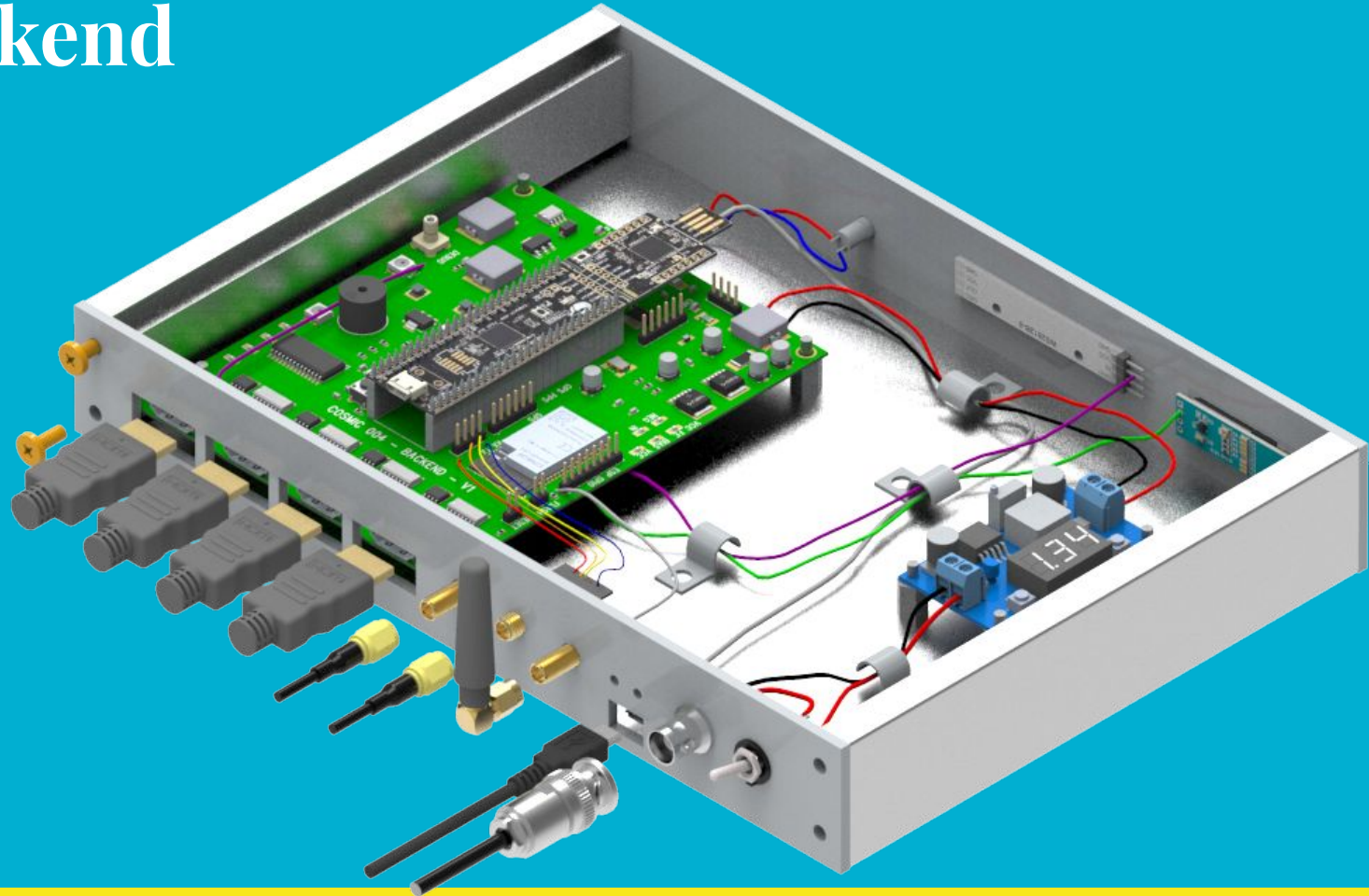

SiPM

1 a 4 Frontends

Backend

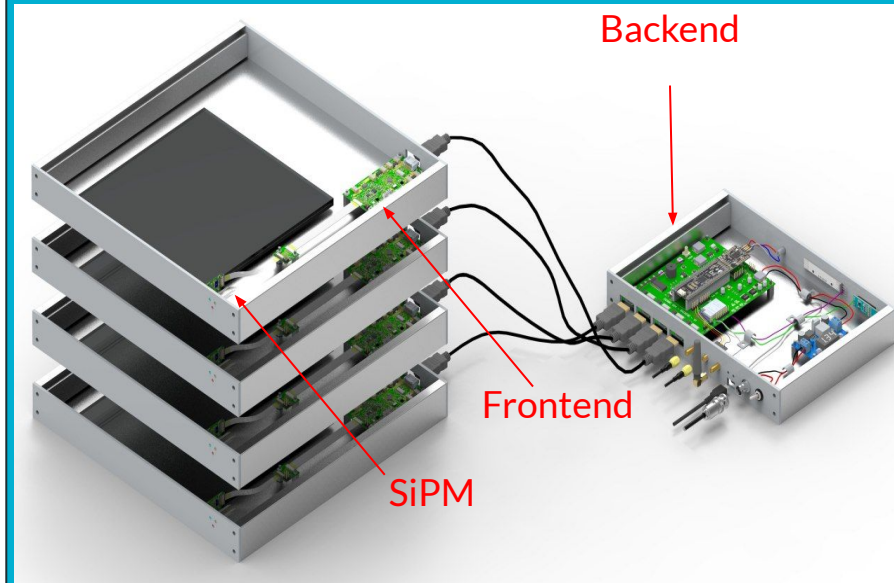
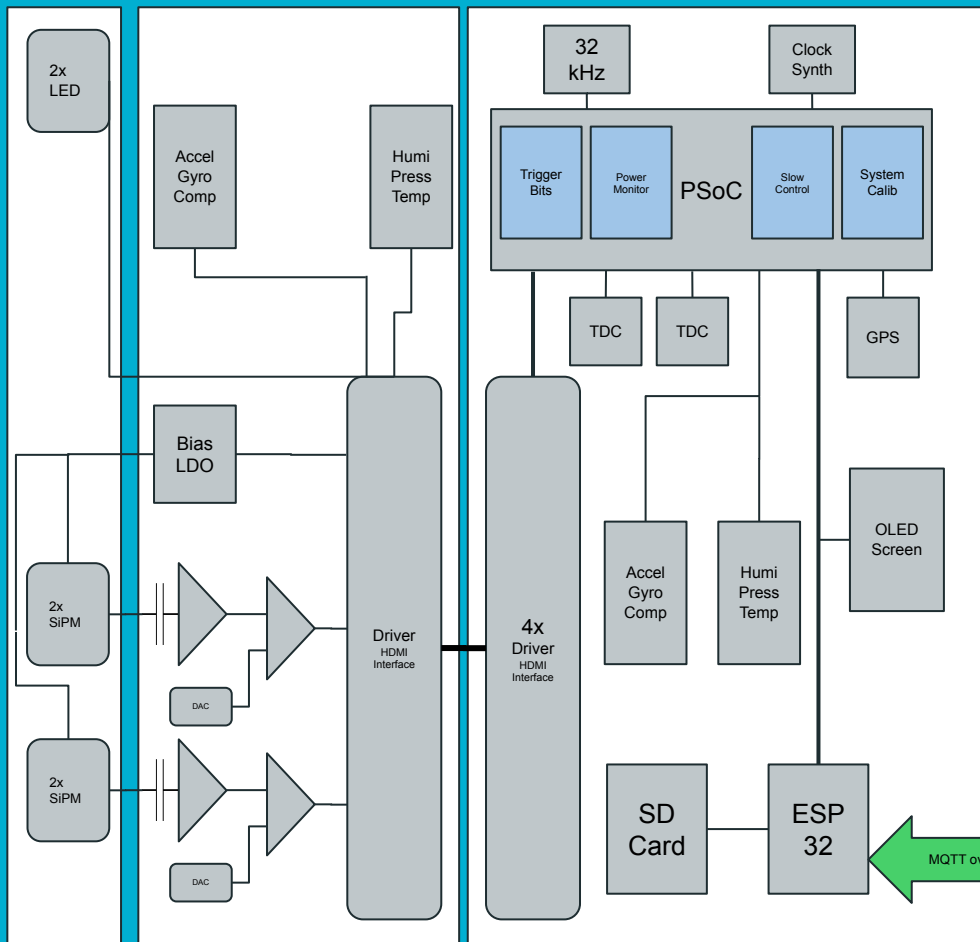

MQTT over Wi-Fi

Placas desenvolvidas

SiPM

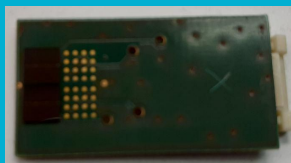

Frontend

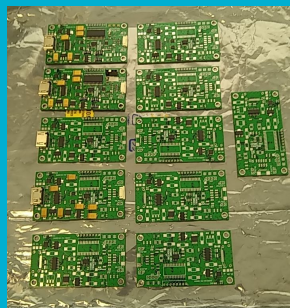

Frontend 2
Já em desenvolvimento

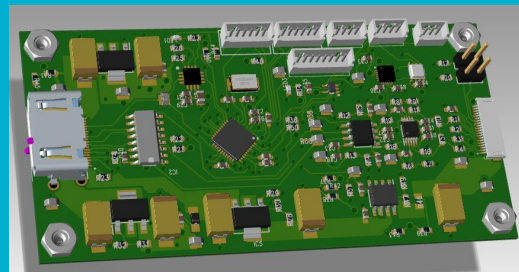

Backend

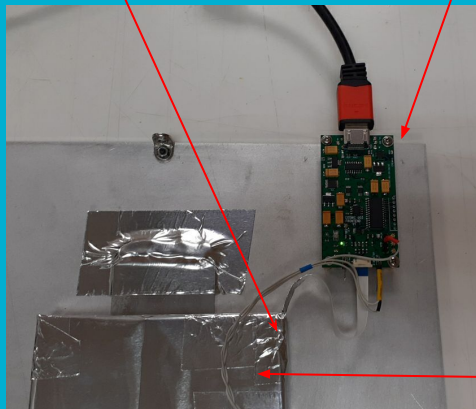

Cintilador

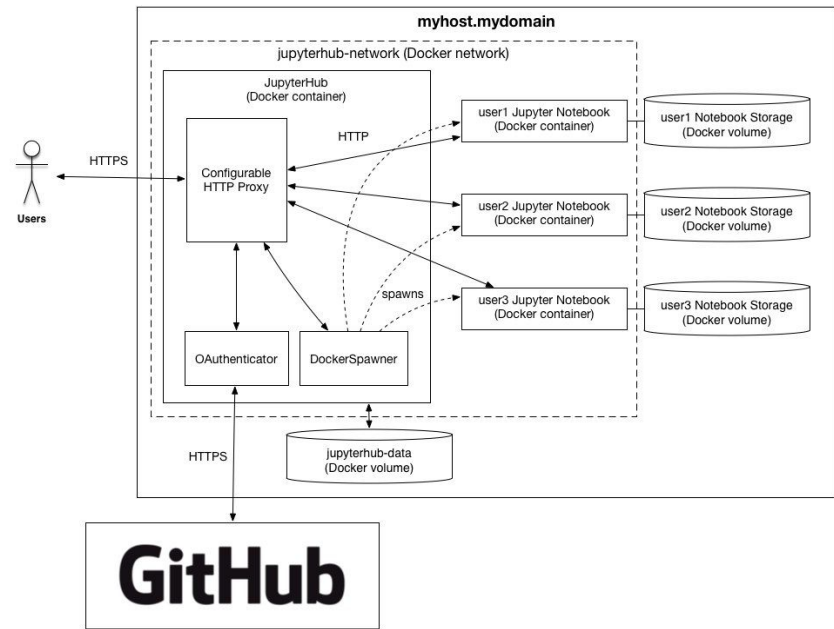
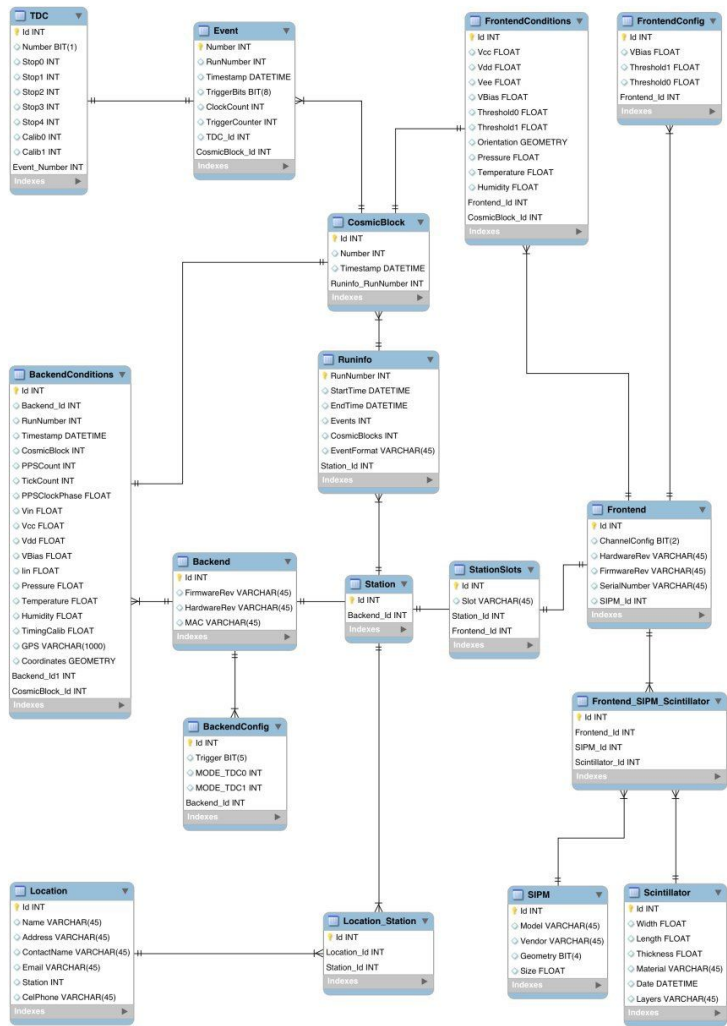

Baseado em um Cypress PSoC 5L

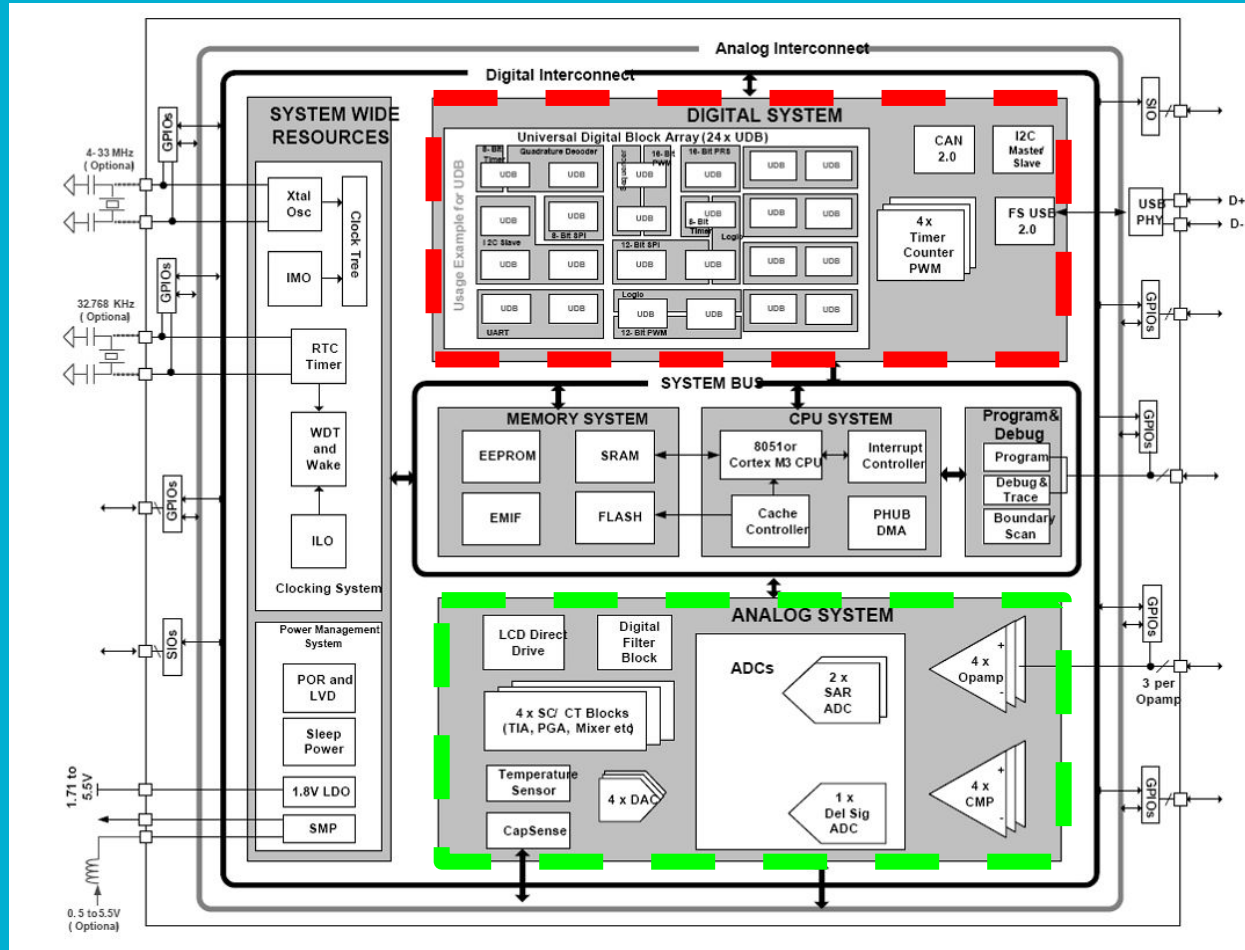

—

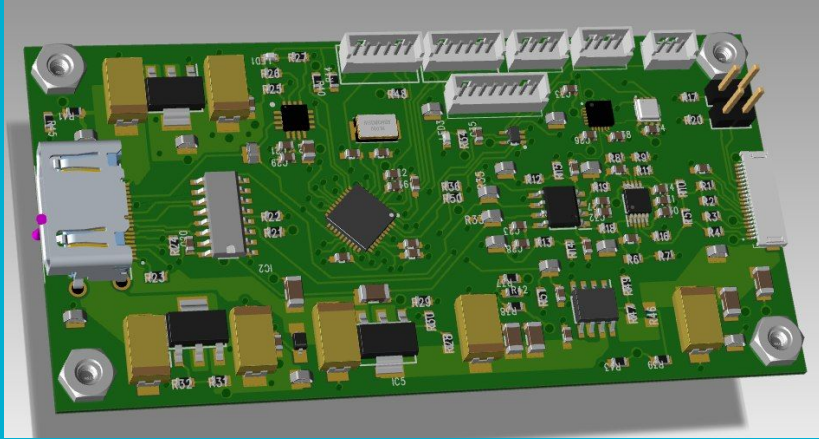

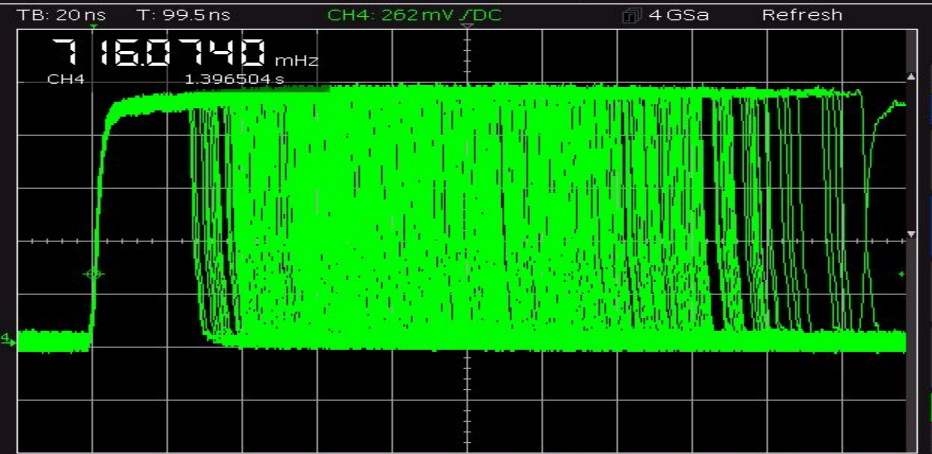

CH4: 200 mV \cong Ω

Dty+: ? f: ?

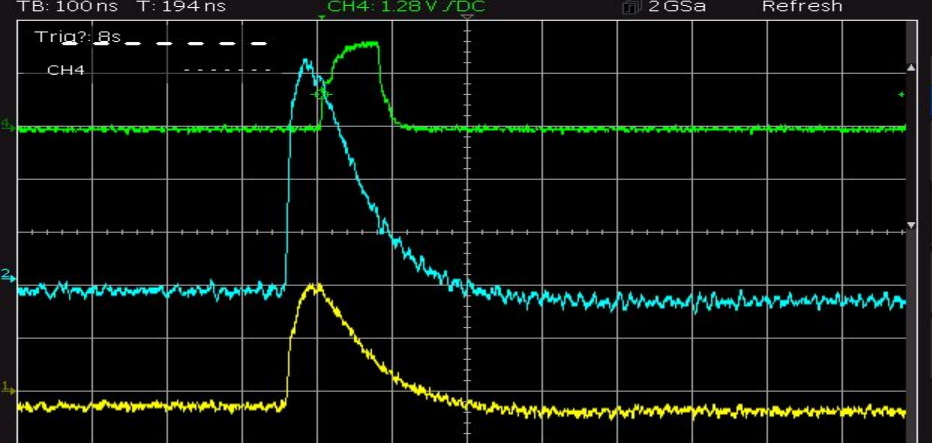

CH2: 50 mV \cong
CH4: 2 V \cong

Dty+: ? f: ?

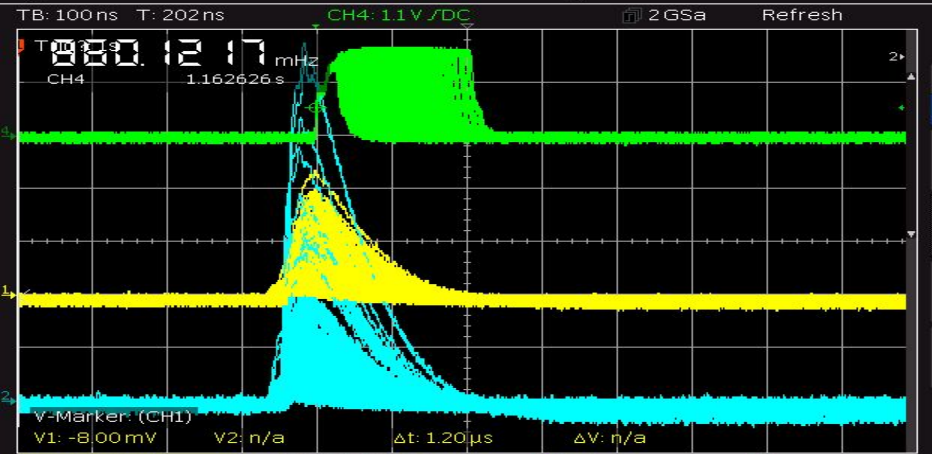

CH1: 200 mV \cong

CH2: 200 mV \cong
CH4: 2 V \cong

Dty+: ? f: ?

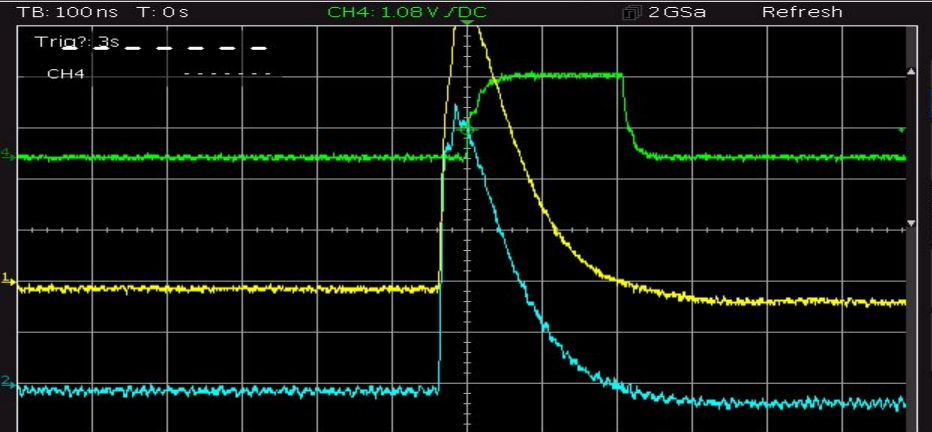

CH1: 100 mV \cong

CH2: 100 mV \cong
CH4: 2 V \cong

Dty+: ? f: ?



Product Index > Sensors, Transducers > Optical Sensors - Ambient Light, IR, UV Sensors > Broadcom Limited AFBR-S4N44C013

Add To Favorites Share

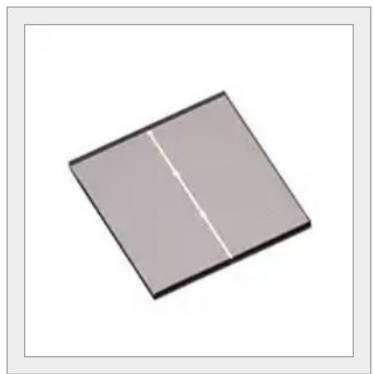

Product Overview	
Digi-Key Part Number	516-4280-ND
Quantity Available	268 Can ship immediately
Manufacturer	Broadcom Limited
Manufacturer Part Number	AFBR-S4N44C013
Description	SENSOR OPT 420NM UV
Manufacturer Standard Lead Time	12 Weeks
Detailed Description	Optical Sensor Ultraviolet (UV) 420nm

Price & Procurement

Quantity

516-4280-ND

Customer Reference

Add to Cart

All prices are in USD.

Price Break	Unit Price	Extended Price
1	26.41000	\$26.41
10	23.33500	\$233.35
100	17.80830	\$1,780.83
500	16.33452	\$8,167.26

Submit a request for quotation on quantities greater than those displayed.

Documents & Media	
Datasheets	AFBR-S4N44C013 Datasheet
Featured Product	AFBR-S4N44C013 NUV-HD Silicon Photomultiplier (SiPM)
Online Catalog	AFBR-S4N44C013

You May Also Be Interested In

